



# **TEST REPORT**

**Report Number:** 13259319-E1V2

**Applicant :** APPLE, INC.  
1 APPLE PARK WAY  
CUPERTINO, CA 95014, U.S.A.

**Model :** A2407, A2408, A2409

**FCC ID :** BCG-E3547A

**IC :** 579C-E3547A

**EUT Description :** SMARTPHONE

**Test Standard(s) :** FCC 47 CFR PART 15 SUBPART C  
ISED RSS-247 ISSUE 2  
ISED RSS-GEN ISSUE 5

**Date of Issue:**  
September 23, 2020

**Prepared by:**  
UL Verification Services Inc.  
47173 Benicia Street  
Fremont, CA 94538 U.S.A.  
TEL: (510) 319-4000  
FAX: (510) 661-0888

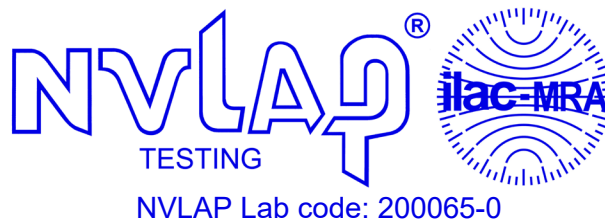

## REPORT REVISION HISTORY

Rev.	Issue Date	Revisions	Revised By
V1	9/21/2020	Initial Issue	Chin Pang
V1	9/23/2020	Addressed TCB question	Vien Tran

## TABLE OF CONTENTS

<b>REPORT REVISION HISTORY .....</b>	<b>2</b>
<b>TABLE OF CONTENTS .....</b>	<b>3</b>
<b>1. ATTESTATION OF TEST RESULTS .....</b>	<b>4</b>
<b>2. TEST RESULTS SUMMARY .....</b>	<b>5</b>
<b>3. TEST METHODOLOGY .....</b>	<b>5</b>
<b>4. FACILITIES AND ACCREDITATION .....</b>	<b>5</b>
<b>5. DECISION RULES AND MEASUREMENT UNCERTAINTY .....</b>	<b>6</b>
5.1. <i>METROLOGICAL TRACEABILITY .....</i>	<i>6</i>
5.2. <i>DECISION RULES.....</i>	<i>6</i>
5.3. <i>MEASUREMENT UNCERTAINTY.....</i>	<i>6</i>
<b>6. INTRODUCTION OF TEST DATA REUSE.....</b>	<b>7</b>
6.1. <i>EUT DESCRIPTION .....</i>	<i>7</i>
6.2. <i>INTRODUCTION .....</i>	<i>7</i>
6.3. <i>DIFFERENCE IN MODEL NUMBER.....</i>	<i>7</i>
6.4. <i>SPOT CHECK VERIFICATION RESULTS SUMMARY .....</i>	<i>7</i>
6.5. <i>REFERENCE DETAIL .....</i>	<i>14</i>
6.6. <i>DESCRIPTION OF AVAILABLE ANTENNAS .....</i>	<i>14</i>
6.7. <i>SOFTWARE AND FIRMWARE.....</i>	<i>14</i>
6.8. <i>WORST-CASE CONFIGURATION AND MODE.....</i>	<i>14</i>
6.9. <i>DESCRIPTION OF TEST SETUP.....</i>	<i>15</i>
<b>7. TEST AND MEASUREMENT EQUIPMENT .....</b>	<b>16</b>
<b>8. MEASUREMENT METHODS .....</b>	<b>16</b>
<b>9. SETUP PHOTOS.....</b>	<b>16</b>
<b>Appendix A – Reference Test Report .....</b>	<b>17</b>

# 1. ATTESTATION OF TEST RESULTS

**COMPANY NAME:** APPLE, INC.  
1 APPLE PARK WAY  
CUPERTINO, CA 95014, U.S.A.

**EUT DESCRIPTION:** SMARTPHONE

**MODEL:** A2407, A2708, A2409

**SERIAL NUMBER:** (Original)" G6TCP01UQ5R9, G6TCM020Q5T6  
(Spot Check): G6TCN009Q5W0, G6TD20AR0RR

**DATE TESTED:** JULY 26, 2020 – JULY 29, 2020

APPLICABLE STANDARDS	
STANDARD	TEST RESULTS
CFR 47 Part 15 Subpart C	Complies
ISED RSS-247 Issue 2	Complies
ISED RSS-GEN Issue 5	Complies

UL Verification Services Inc. tested the above equipment in accordance with the requirements set forth in the above standards. The test results show that the equipment tested is capable of demonstrating compliance with the requirements as documented in this report.

The results documented in this report apply only to the tested sample, under the conditions and modes of operation as described herein. It is the manufacturer's responsibility to assure that additional production units of this model are manufactured with identical electrical and mechanical components. All samples tested were in good operating condition throughout the entire test program. Measurement Uncertainties are published for informational purposes only and were not taken into account unless noted otherwise.

This document may not be altered or revised in any way unless done so by UL Verification Services Inc. and all revisions are duly noted in the revisions section. Any alteration of this document not carried out by UL Verification Services Inc. will constitute fraud and shall nullify the document. This report must not be used by the client to claim product certification, approval, or endorsement by NVLAP, NIST, any agency of the Federal Government, or any agency of the U.S. government.

Approved & Released For  
UL Verification Services Inc. By:



Chin Pang  
Senior Engineer  
Consumer Technology Division  
UL Verification Services Inc.

Prepared By:



Tony Li  
Test Engineer  
Consumer Technology Division  
UL Verification Services Inc.

## 2. TEST RESULTS SUMMARY

FCC Clause	ISED Clause	Requirement	Result	Comment
15.209, 15.205	RSS-GEN 8.9, 8.10	Radiated Emissions	Complies	None.

## 3. TEST METHODOLOGY

The tests documented in this report were performed in accordance with FCC CFR 47 Part 2, FCC CFR 47 Part 15, ANSI C63.10-2013, KDB 558074 D01 15.247 Meas Guidance v05r02, KDB 662911, RSS-GEN Issue 5, and RSS-247 Issue 2.

## 4. FACILITIES AND ACCREDITATION

The test sites and measurement facilities used to collect data are located at 47173 and 47266 Benicia Street, and 47658 Kato Road, Fremont, California, USA. Line conducted emissions are measured only at the 47173 address. The following table identifies which facilities were utilized for radiated emission measurements documented in this report. Specific facilities are also identified in the test results sections.

47173 Benicia Street	47266 Benicia Street	47658 Kato Road
<input type="checkbox"/> Chamber A	<input type="checkbox"/> Chamber D	<input type="checkbox"/> Chamber I
<input type="checkbox"/> Chamber B	<input type="checkbox"/> Chamber E	<input checked="" type="checkbox"/> Chamber J
<input type="checkbox"/> Chamber C	<input type="checkbox"/> Chamber F	<input checked="" type="checkbox"/> Chamber K
	<input type="checkbox"/> Chamber G	<input type="checkbox"/> Chamber L
	<input type="checkbox"/> Chamber H	<input type="checkbox"/> Chamber M

The above test sites and facilities are covered under FCC Test Firm Registration # 208313. Chambers above are covered under Industry Canada company address and respective code: 2324A.

UL Verification Services Inc. is accredited by NVLAP, Laboratory Code 200065-0

## 5. DECISION RULES AND MEASUREMENT UNCERTAINTY

### 5.1. METROLOGICAL TRACEABILITY

All test and measuring equipment utilized to perform the tests documented in this report are calibrated on a regular basis, with a maximum time between calibrations of one year or the manufacturers' recommendation, whichever is less, and where applicable is traceable to recognized national standards.

### 5.2. DECISION RULES

The Decision Rule is based on Simple Acceptance in accordance with ISO Guide 98-4:2012 Clause 8.2. (Measurement uncertainty is not taken into account when stating conformity with a specified requirement.)

### 5.3. MEASUREMENT UNCERTAINTY

Where relevant, the following measurement uncertainty levels have been estimated for tests performed on the apparatus:

PARAMETER	U <sub>Lab</sub>
Worst Case Conducted Disturbance, 9KHz to 0.15 MHz	3.39 dB
Worst Case Conducted Disturbance, 0.15 to 30 MHz	3.07 dB
Worst Case Radiated Disturbance, 9KHz to 30 MHz	2.52 dB
Worst Case Radiated Disturbance, 30 to 1000 MHz	4.88 dB
Worst Case Radiated Disturbance, 1000 to 18000 MHz	4.24 dB
Worst Case Radiated Disturbance, 18000 to 26000 MHz	4.37 dB
Worst Case Radiated Disturbance, 26000 to 40000 MHz	5.17 dB

Uncertainty figures are valid to a confidence level of 95%.

## 6. INTRODUCTION OF TEST DATA REUSE

### 6.1. EUT DESCRIPTION

The Apple iPhone is a smartphone with multimedia functions (music, application support, and video), cellular GSM, GPRS, EGPRS, UMTS, LTE, 5G, CDMA, IEEE 802.11a/b/g/n/ac/ax, Bluetooth, Ultra-Wideband, GPS, NFC and WPT. All models support at least one UICC based SIM. The second SIM is either an UICC based p-SIM (physical SIM) or e-SIM (electronic SIM). The device supports a built-in inductive charging transmitter and receiver. The rechargeable battery is not user accessible.

### 6.2. INTRODUCTION

This application for certification is leveraging the data reuse procedures from KDB 484596 D01 based on reference FCC ID: BCG-E3545A, IC: 579C-E3545A to cover variant model BCG-E3547A, 579C-E3547A. The major difference between the parent/reference model and the variant model is the depopulation in the variant model of the mmWave transmitter. All other circuitry and features are identical. The data reuse test plan was approved via manufacturer KDB inquiry.

### 6.3. DIFFERENCE IN MODEL NUMBER

Models A2407, A2408, and A2409 are electrically identical and the model numbers are allocated for marketing and logistic purposes only. Model A2407 was used for the spot check testing described in this report.

### 6.4. SPOT CHECK VERIFICATION RESULTS SUMMARY

Spot check verification has been done on device model A2407, FCC ID: BCG-E3547A, IC: 579C-E3547A for radiated spurious and radiated band-edge in accordance with the Test Plan that was approved via KDB inquiry.

BCG-E3547A, 579C-E3547A SPOT CHECK RESULTS										
Technology	Mode	Test Item	Channel	Measured	Original model		Spot check model		Delta (dB)	
					BCG-E3545A 579C-E3545A		BCG-E3547A 579C-E3547A			
				Frequency (MHz)	Peak	Ave	Peak	Ave	Peak	Ave
BT	GFSK	RBE	low	2390.0	55.14	45.17	54.49	40.37	0.65	-4.8
			high	2483.5	54.67	42.17	55.84	41.58	1.17	-0.59
	GFSK	RSE	Mid	12382.70	50.73	37.41	NF	NF	NA	NA

Comparison of the models, upper deviation is within 3dB range and all tests are under FCC Technical Limits. The test report for FCC ID BCG-E3545A, IC: 579C-E3545A is therefore being used to support the application for certification for FCC ID: BCG-E3547A & IC: 579C-E3547A.

Note: NF—Noise Floor.

Note: The output powers were verified on model A2407 to match with model A2341 before radiated emissions spot check was performed.

**SPOT CHECK DATA**

**BANDEDGE (LOW CHANNEL)**

**HORIZONTAL RESULT**

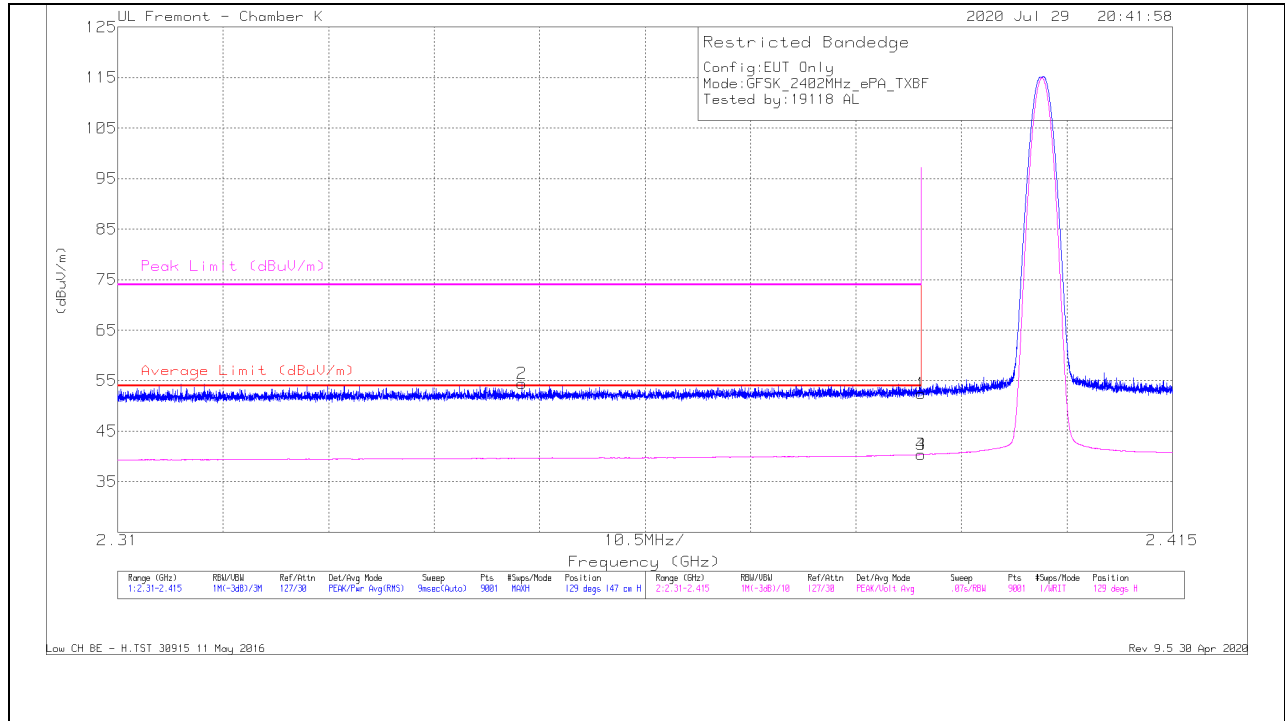

Marker	Frequency (GHz)	Meter Reading (dBuV)	Det	AF EMC4294 (dB/m)	Amp/Cbl/Fitr/Pad (dB)	Corrected Reading (dBuV/m)	Average Limit (dBuV/m)	Margin (dB)	Peak Limit (dBuV/m)	PK Margin (dB)	Azimuth (Degs)	Height (cm)	Polarity
1	* 2.38999	55.51	Pk	31.9	-35	52.41	-	-	74	-21.59	129	147	H
2	* 2.35025	57.99	Pk	31.7	-35.2	54.49	-	-	74	-19.51	129	147	H
3	* 2.38999	43.47	VA1T	31.9	-35	40.37	54	-13.63	-	-	129	146	H
4	* 2.38998	43.47	VA1T	31.9	-35	40.37	54	-13.63	-	-	129	146	H

\* - indicates frequency in CFR47 Pt 15 / IC RSS-Restricted Band  
 Pk - Peak detector  
 VA1T - FHSS: Linear Voltage Average VB=1/Ton where: Ton is transmit duration



### VERTICAL RESULT

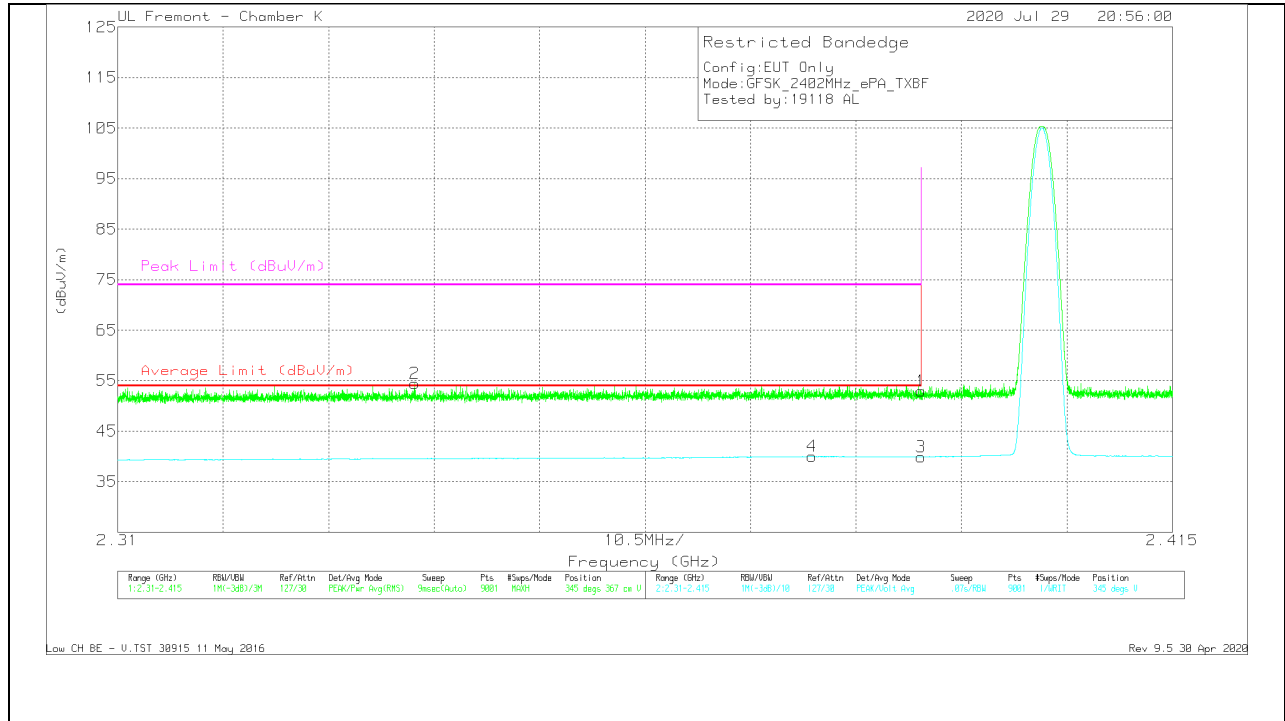

Marker	Frequency (GHz)	Meter Reading (dBuV)	Det	AF EMC4294 (dB/m)	Amp/CbI/Fitr/Pa d (dB)	Corrected Reading (dBuV/m)	Average Limit (dBuV/m)	Margin (dB)	Peak Limit (dBuV/m)	PK Margin (dB)	Azimuth (Degs)	Height (cm)	Polarity
1	* 2.38999	56.02	Pk	31.9	-35	52.92	-	-	74	-21.08	345	367	V
2	* 2.33954	57.9	Pk	31.7	-35.2	54.4	-	-	74	-19.6	345	367	V
3	* 2.38999	43.04	VA1T	31.9	-35	39.94	54	-14.06	-	-	345	367	V
4	* 2.37913	43.14	VA1T	31.9	-35	40.04	54	-13.96	-	-	345	367	V

\* - indicates frequency in CFR47 Pt 15 / IC RSS-Restricted Band  
 Pk - Peak detector  
 VA1T - FHSS: Linear Voltage Average VB=1/Ton where: Ton is transmit duration

**BANDEDGE (HIGH CHANNEL)**

**HORIZONTAL RESULT**

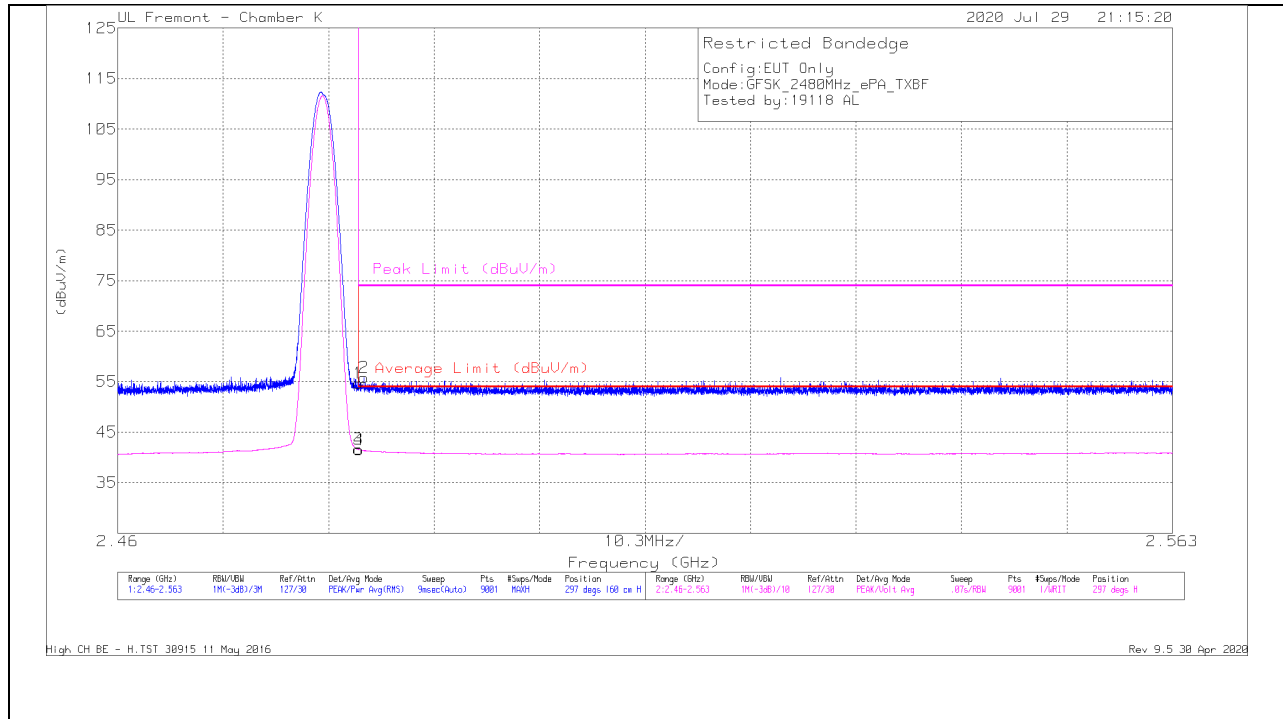

Marker	Frequency (GHz)	Meter Reading (dBuV)	Det	AF EMC4294 (dB/m)	Amp/Cbl/Fitr/Paid (dB)	Corrected Reading (dBuV/m)	Average Limit (dBuV/m)	Margin (dB)	Peak Limit (dBuV/m)	PK Margin (dB)	Azimuth (Degs)	Height (cm)	Polarity
1	* 2.48351	56.76	Pk	32.5	-34.6	54.66	-	-	74	-19.34	297	160	H
2	* 2.48407	57.94	Pk	32.5	-34.6	55.84	-	-	74	-18.16	297	160	H
3	* 2.48351	43.68	VA1T	32.5	-34.6	41.58	54	-12.42	-	-	297	160	H
4	* 2.48356	43.63	VA1T	32.5	-34.6	41.53	54	-12.47	-	-	297	160	H

\* - indicates frequency in CFR47 Pt 15 / IC RSS-Restricted Band  
 Pk - Peak detector  
 VA1T - FHSS: Linear Voltage Average VB=1/Ton where: Ton is transmit duration

### VERTICAL RESULT

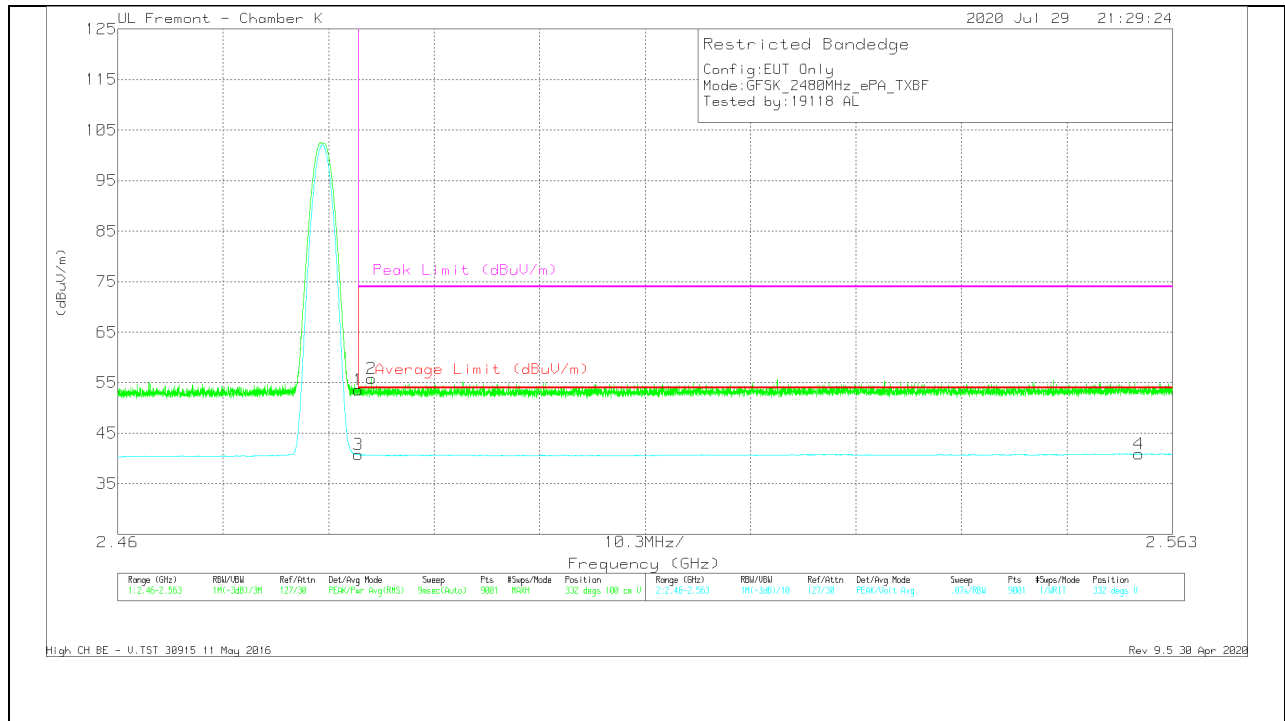

Marker	Frequency (GHz)	Meter Reading (dBuV)	Det	AF EMC4294 (dB/m)	Amp/Cb/Fitr/Pa d (dB)	Corrected Reading (dBuV/m)	Average Limit (dBuV/m)	Margin (dB)	Peak Limit (dBuV/m)	PK Margin (dB)	Azimuth (Degs)	Height (cm)	Polarity
1	* 2.48351	55.68	Pk	32.5	-34.6	53.58	-	-	74	-20.42	332	100	V
2	* 2.48478	57.92	Pk	32.5	-34.6	55.82	-	-	74	-18.18	332	100	V
3	* 2.48351	42.82	VA1T	32.5	-34.6	40.72	54	-13.28	-	-	332	100	V
4	2.55972	42.77	VA1T	32.5	-34.4	40.87	54	-13.13	-	-	332	100	V

\* - indicates frequency in CFR47 Pt 15 / IC RSS-Restricted Band  
 Pk - Peak detector  
 VA1T - FHSS: Linear Voltage Average VB=1/Ton where: Ton is transmit duration

# HARMONICS AND SPURIOUS EMISSIONS

## MID CHANNEL RESULTS

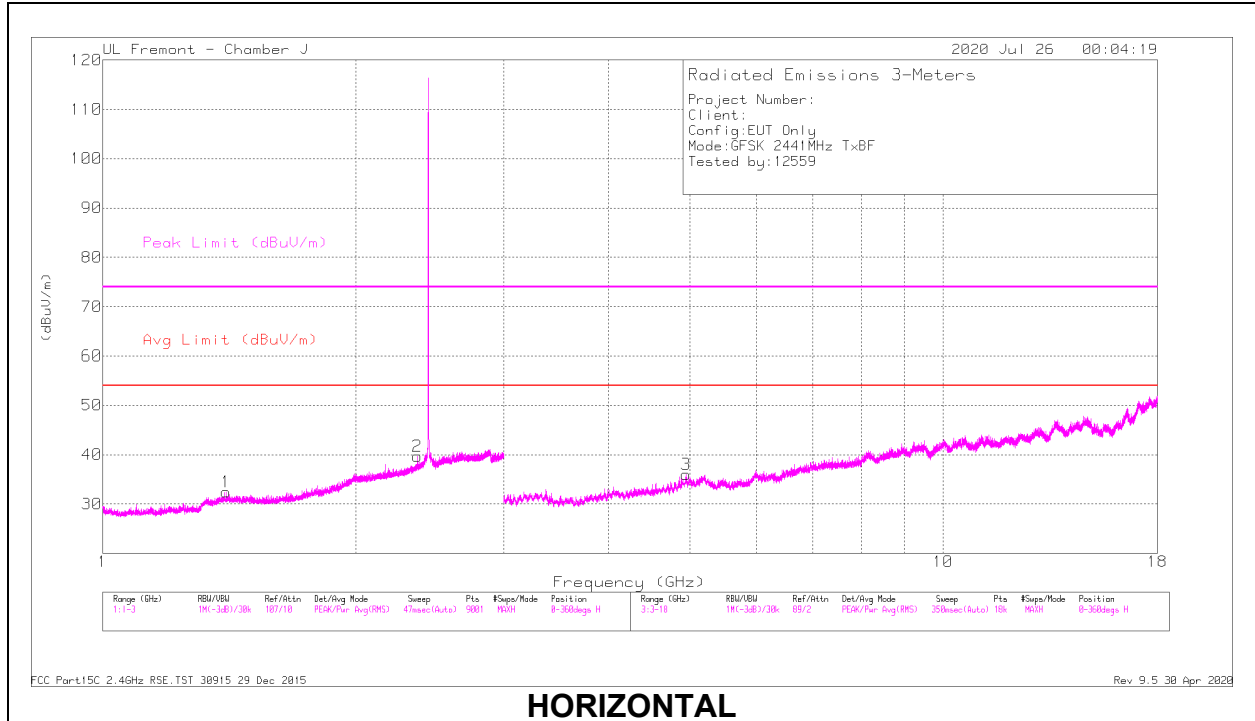

**HORIZONTAL**

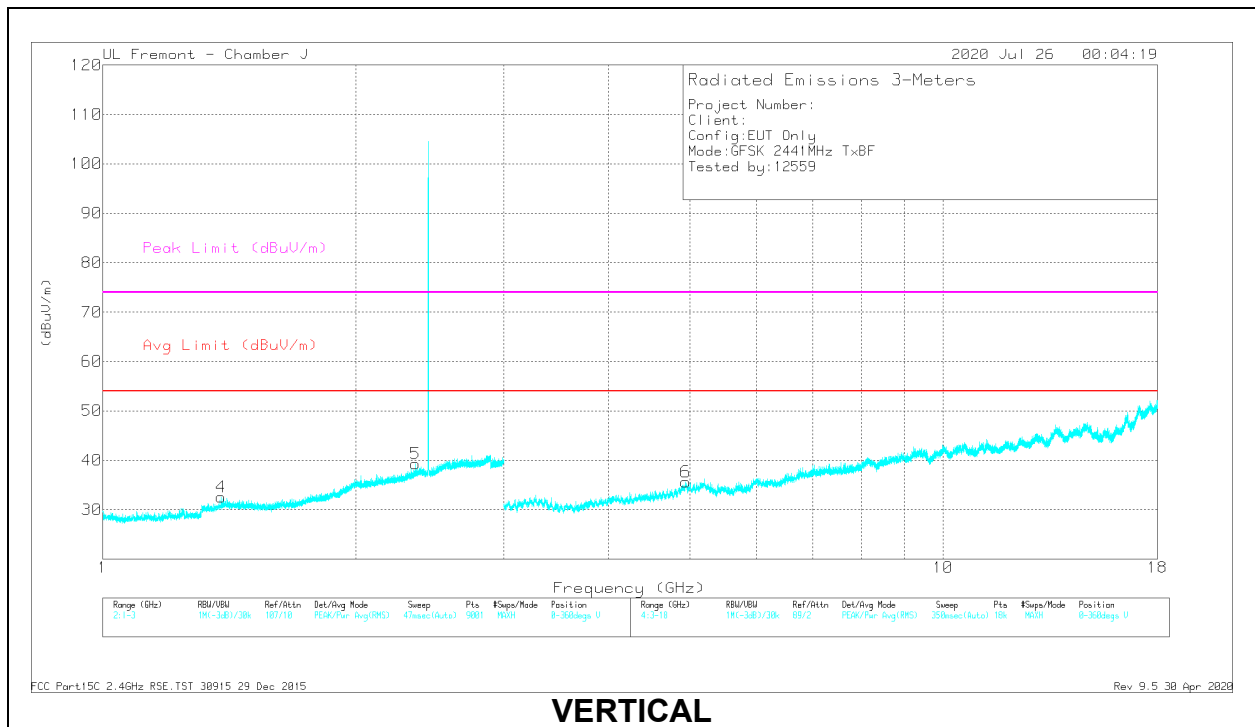

**VERTICAL**

**RADIATED EMISSIONS**

Marker	Frequency (GHz)	Meter Reading (dBuV)	Det	AF T963 (dB/m)	Amp/Cbl/Filtr/P ad (dB)	Corrected Reading (dBuV/m)	Avg Limit (dBuV/m)	Margin (dB)	Peak Limit (dBuV/m)	PK Margin (dB)	Azimuth (Degs)	Height (cm)	Polarity
1	* 1.40203	31.2	PKFH	25.8	-17.4	39.6	-	-	74	-34.4	360	121	H
	* 1.40371	17.82	VA1T	25.8	-17.3	26.32	54	-27.68	-	-	360	121	H
2	* 2.36648	31.77	PKFH	29	-14.8	45.97	-	-	74	-28.03	286	149	H
	* 2.36626	19.65	VA1T	29	-14.8	33.85	54	-20.15	-	-	286	149	H
4	* 1.38491	31.27	PKFH	25.8	-17.4	39.67	-	-	74	-34.33	331	126	V
	* 1.38489	18.11	VA1T	25.8	-17.4	26.51	54	-27.49	-	-	331	126	V
5	* 2.35713	32.27	PKFH	29	-14.9	46.37	-	-	74	-27.63	146	195	V
	* 2.3581	18.53	VA1T	29	-14.8	32.73	54	-21.27	-	-	146	195	V
3	* 4.95179	39.58	PKFH	33.8	-30	43.38	-	-	74	-30.62	172	181	H
	* 4.94932	26.43	VA1T	33.8	-30	30.23	54	-23.77	-	-	172	181	H
6	* 4.94083	40.46	PKFH	33.8	-30.1	44.16	-	-	74	-29.84	323	117	V
	* 4.94198	26.57	VA1T	33.8	-30	30.37	54	-23.63	-	-	323	117	V

\* - indicates frequency in CFR47 Pt 15 / IC RSS-Restricted Band  
 PKFH FHSS/BT RB=100k for Frequencies<1GHz / RB=1MHz for Frequencies>1GHz, VB=3 x RB, Peak  
 VA1T - FHSS: Linear Voltage Average VB=1/Ton where: Ton is transmit duration

### 6.5. REFERENCE DETAIL

Reference application that contains the reused reference data which is attached to this report in Appendix A.

Equipment Class	Reference FCC ID & IC	Reference Report	Report Title/Section
DSS	BCG-E3545A 579C-E3545A	13259315-E1	FCC IC_BT Report / All sections

### 6.6. DESCRIPTION OF AVAILABLE ANTENNAS

Frequency Range (GHz)	ANT 4 (dBi)	ANT 3 (dBi)
2.4	-1.9	0.4

### 6.7. SOFTWARE AND FIRMWARE

The EUT firmware installed during testing was 18.1.148.558

### 6.8. WORST-CASE CONFIGURATION AND MODE

Radiated band edge and spurious emissions from 1GHz to 18GHz were performed based on the Model A2341 worst case with the EUT set at highest power at Low/Mid/High channel.

There are two vendors of the WiFi/Bluetooth radio modules: variant 1 and variant 2. The Wi-Fi/Bluetooth radio modules have the same mechanical outline (e.g., the same package dimension and pin-out layout), use the same on-board antenna matching circuit, have an identical antenna structure, and are built and tested to conform to the same specifications and to operate within the same tolerances.

### 6.9. DESCRIPTION OF TEST SETUP

SUPPORT TEST EQUIPMENT						
Description	Manufacturer	Model	Serial Number	FCC ID/ DoC		
Laptop	Apple	A1502	HRP003436	QDS-BRCM1080		
Laptop AC/DC adapter	Liteon Technology	PA-1450-BA1	B123	NA		
EUT AC/DC adapter	Apple	A1385	D29325SM03XDHLHC9	NA		
I/O CABLES (RF RADIATED TEST)						
Cable No.	Port	# of Identical Ports	Connector Type	Cable Type	Cable Length (m)	Remarks
1	AC	1	AC	Un-shielded	2	N/A
2	USB	1	USB	Un-shielded	1	N/A

#### TEST SETUP

The EUT is connected to a test laptop during the tests. Test software exercised the radio card.

#### SETUP DIAGRAM FOR RADIATED TESTS Above 1 GHz

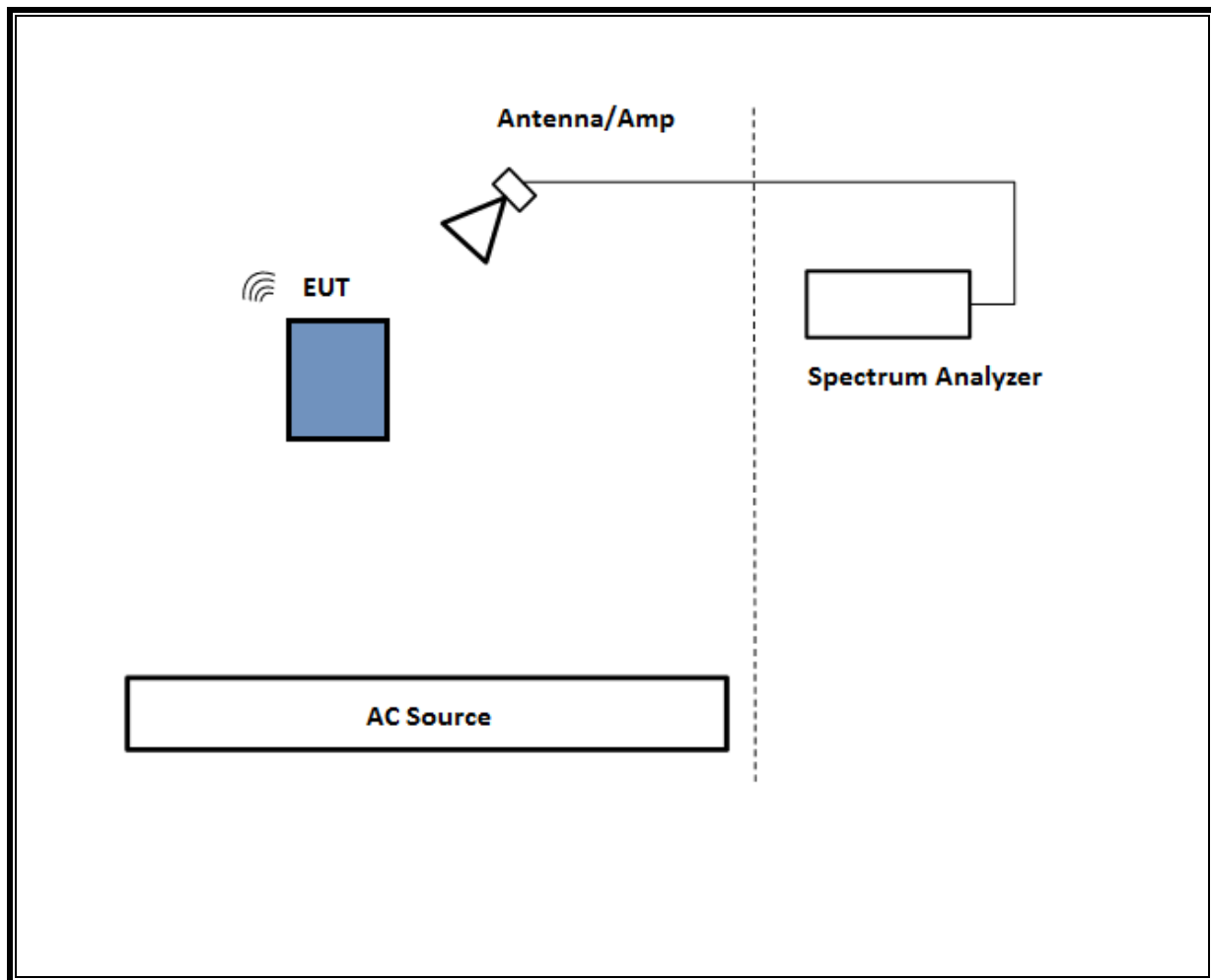

## 7. TEST AND MEASUREMENT EQUIPMENT

The following test and measurement equipment was utilized for the tests documented in this report:

TEST EQUIPMENT LIST					
Description	Manufacturer	Model	ID Num	Cal Due	Last Cal
Antenna, Horn 1-18GHz	ETS Lindgren	3117	EMC4294	11/01/2020	11/01/2019
Amplifier, 1 to 18GHz, 35dB	AMPLICAL	AMP1G18-35	T1569	01/30/2021	01/30/2020
Antenna, Double Ridge Guide Horn Antenna	A.H. Systems, Inc.	SAS-571	T963	01/25/2021	01/25/2020
EMI Test Receiver	Rohde & Schwarz	ESW44	Pre0179372	02/25/2021	02/25/2020
EMI Test Receiver	Rohde & Schwarz	ESW44	Pre0179522	02/20/2021	02/20/2020
Power Meter, P-series single channel	Keysight	N1911A	PRE0177682	01/21/2021	01/21/2020
Power Sensor	Keysight	N1921A	T1226	02/13/2021	02/13/2020

UL AUTOMATION SOFTWARE			
Radiated Software	UL	UL EMC	Ver 9.5, Mar 6, 2020

## 8. MEASUREMENT METHODS

Peak Output Power: ANSI C63.10-2013 Section 7.8.5

Radiated Spurious Emissions above 1GHz: ANSI C63.10-2013 Section 6.3, 6.6 & 13

Radiated Band-edge: ANSI C63.10-2013 Section 6.10.5 & section 13

## 9. SETUP PHOTOS

Please refer to 13259315-EP1 for setup photos



## Appendix A – Reference Test Report

Attached is the test report (13259315-E1) containing the reference data from the parent model as detailed in section 6.5.



# **TEST REPORT**

**Report Number:** 13259315-E1V3

**Applicant :** APPLE, INC.  
1 APPLE PARK WAY  
CUPERTINO, CA 95014, U.S.A.

**Model :** A2341

**FCC ID :** BCG-E3545A

**IC :** 579C-E3545A

**EUT Description :** SMARTPHONE

**Test Standard(s) :** FCC 47 CFR PART 15 SUBPART C  
ISED RSS-247 ISSUE 2  
ISED RSS-GEN ISSUE 5

**Date Of Issue:**  
September 21, 2020

**Prepared by:**  
UL Verification Services Inc.  
47173 Benicia Street  
Fremont, CA 94538 U.S.A.  
TEL: (510) 319-4000  
FAX: (510) 661-0888



NVLAP Lab code: 200065-0

## REPORT REVISION HISTORY

Rev.	Issue Date	Revisions	Revised By
V1	8/26/2020	Initial Issue	Chin Pang
V2	9/18/2020	Address TCB's Questions	Chin Pang
V3	9/21/2020	Address TCB's Questions	Chin Pang

## TABLE OF CONTENTS

<b>REPORT REVISION HISTORY .....</b>	<b>2</b>
<b>TABLE OF CONTENTS .....</b>	<b>3</b>
<b>1. ATTESTATION OF TEST RESULTS .....</b>	<b>6</b>
<b>2. TEST RESULTS SUMMARY .....</b>	<b>7</b>
<b>3. TEST METHODOLOGY .....</b>	<b>7</b>
<b>4. FACILITIES AND ACCREDITATION .....</b>	<b>7</b>
<b>5. DECISION RULES AND MEASUREMENT UNCERTAINTY .....</b>	<b>8</b>
5.1. <i>METROLOGICAL TRACEABILITY .....</i>	<i>8</i>
5.2. <i>DECISION RULES.....</i>	<i>8</i>
5.3. <i>MEASUREMENT UNCERTAINTY.....</i>	<i>8</i>
<b>6. EQUIPMENT UNDER TEST .....</b>	<b>9</b>
6.1. <i>EUT DESCRIPTION .....</i>	<i>9</i>
6.2. <i>MAXIMUM OUTPUT POWER.....</i>	<i>9</i>
6.3. <i>DESCRIPTION OF AVAILABLE ANTENNAS .....</i>	<i>9</i>
6.4. <i>SOFTWARE AND FIRMWARE.....</i>	<i>10</i>
6.5. <i>WORST-CASE CONFIGURATION AND MODE.....</i>	<i>10</i>
6.6. <i>DESCRIPTION OF TEST SETUP.....</i>	<i>11</i>
<b>7. TEST AND MEASUREMENT EQUIPMENT .....</b>	<b>16</b>
<b>8. MEASUREMENT METHODS .....</b>	<b>17</b>
<b>9. ANTENNA PORT TEST RESULTS .....</b>	<b>18</b>
9.1. <i>ON TIME AND DUTY CYCLE.....</i>	<i>18</i>
9.2. <i>20 dB AND 99% BANDWIDTH .....</i>	<i>19</i>
9.2.1. <i>HIGH POWER BASIC DATA RATE GFSK MODULATION.....</i>	<i>20</i>
9.2.2. <i>HIGH POWER ENHANCED DATA RATE 8PSK MODULATION .....</i>	<i>21</i>
9.2.3. <i>HIGH POWER BASIC DATA RATE TXBF GFSK MODULATION.....</i>	<i>22</i>
9.2.4. <i>HIGH POWER ENHANCED DATA RATE TXBF 8PSK MODULATION .....</i>	<i>23</i>
9.3. <i>HOPPING FREQUENCY SEPARATION .....</i>	<i>24</i>
9.3.1. <i>HIGH POWER BASIC DATA RATE GFSK MODULATION.....</i>	<i>24</i>
9.4. <i>NUMBER OF HOPPING CHANNELS.....</i>	<i>25</i>
9.4.1. <i>HIGH POWER BASIC DATA RATE GFSK MODULATION .....</i>	<i>26</i>
9.5. <i>AVERAGE TIME OF OCCUPANCY.....</i>	<i>28</i>
9.5.1. <i>HIGH POWER BASIC DATA RATE GFSK MODULATION.....</i>	<i>29</i>

- 9.6. OUTPUT POWER.....33
  - 9.6.1. HIGH POWER BASIC DATA RATE GFSK MODULATION.....34
  - 9.6.2. HIGH POWER ENHANCED DATA RATE QPSK MODULATION .....34
  - 9.6.3. HIGH POWER ENHANCED DATA RATE 8PSK MODULATION .....35
  - 9.6.4. LOW POWER BASIC DATA RATE GFSK MODULATION.....35
  - 9.6.5. LOW POWER ENHANCED DATA RATE QPSK MODULATION .....36
  - 9.6.6. LOW POWER ENHANCED DATA RATE 8PSK MODULATION .....36
  - 9.6.7. HIGH POWER BASIC DATA RATE TXBF GFSK MODULATION.....37
  - 9.6.8. HIGH POWER ENHANCED DATA RATE TXBF QPSK MODULATION .....37
  - 9.6.9. HIGH POWER ENHANCED DATA RATE TXBF 8PSK MODULATION .....37
  - 9.6.10. LOW POWER BASIC DATA RATE TXBF GFSK MODULATION .....38
  - 9.6.11. LOW POWER ENHANCED DATA RATE TXBF QPSK MODULATION.....38
  - 9.6.12. LOW POWER ENHANCED DATA RATE TXBF 8PSK MODULATION .....38
- 9.7. AVERAGE POWER.....39
  - 9.7.1. HIGH POWER BASIC DATA RATE GFSK MODULATION.....40
  - 9.7.2. HIGH POWER ENHANCED DATA RATE QPSK MODULATION .....40
  - 9.7.3. HIGH POWER ENHANCED DATA RATE 8PSK MODULATION .....41
  - 9.7.4. LOW POWER BASIC DATA RATE GFSK MODULATION.....41
  - 9.7.5. LOW POWER ENHANCED DATA RATE QPSK MODULATION .....42
  - 9.7.6. LOW POWER ENHANCED DATA RATE 8PSK MODULATION .....42
  - 9.7.7. HIGH POWER BASIC DATA RATE TXBF GFSK MODULATION.....43
  - 9.7.8. HIGH POWER ENHANCED RATE TXBF QPSK MODULATION.....43
  - 9.7.9. HIGH POWER ENHANCED DATA RATE TXBF 8PSK MODULATION .....43
  - 9.7.10. LOW POWER BASIC DATA RATE TXBF GFSK MODULATION .....44
  - 9.7.11. LOW POWER ENHANCED DATA RATE TXBF QPSK MODULATION.....44
  - 9.7.12. LOW POWER ENHANCED DATA RATE TXBF 8PSK MODULATION .....44
- 9.8. CONDUCTED SPURIOUS EMISSIONS.....45
  - 9.8.1. HIGH POWER BASIC DATA RATE GFSK MODULATION.....46
  - 9.8.2. HIGH POWER ENHANCED DATA RATE 8PSK MODULATION .....50
  - 9.8.3. LOW POWER BASIC DATA RATE GFSK MODULATION.....54
  - 9.8.4. LOW POWER ENHANCED DATA RATE 8PSK MODULATION .....58
  - 9.8.5. HIGH POWER BASIC DATA RATE TXBF GFSK MODULATION.....62
  - 9.8.6. HIGH POWER ENHANCED DATA RATE TXBF 8PSK MODULATION .....66
  - 9.8.7. LOW POWER BASIC DATA RATE TXBF GFSK MODULATION.....70
  - 9.8.8. LOW POWER ENHANCED DATA RATE TXBF 8PSK MODULATION .....74
- 10. RADIATED TEST RESULTS .....78
  - 10.1. TRANSMITTER ABOVE 1 GHz.....80
    - 10.1.1. HIGH POWER BASIC DATA RATE GFSK MODULATION .....80
    - 10.1.2. HIGH POWER ENHANCED DATA RATE 8PSK MODULATION.....88
    - 10.1.3. LOW POWER BASIC DATA RATE GFSK MODULATION .....96
    - 10.1.4. LOW POWER ENHANCED DATA RATE 8PSK MODULATION .....104
    - 10.1.5. HIGH POWER BASIC DATA RATE TX BF GFSK MODULATION .....112
    - 10.1.6. HIGH POWER BASIC DATA RATE TXBF 8PSK MODULATION.....116
    - 10.1.7. LOW POWER BASIC DATA RATE TXBF GFSK MODULATION .....120
    - 10.1.8. LOW POWER BASIC DATA RATE TXBF 8PSK MODULATION.....124
    - 10.1.9. HIGH POWER HARMONICS AND SPURIOUS TXBF GFSK MODULATION  
128
  - 10.2. WORST CASE BELOW 1 GHZ.....134

---

10.3.	WORST CASE 18-26 GHZ.....	136
<b>11.</b>	<b>AC POWER LINE CONDUCTED EMISSIONS .....</b>	<b>138</b>
11.1.	AC Power Line With Laptop.....	139
11.2.	AC Power Line With AC/DC Adapter.....	141
<b>12.</b>	<b>SETUP PHOTOS .....</b>	<b>143</b>

# 1. ATTESTATION OF TEST RESULTS

**COMPANY NAME:** APPLE, INC.  
1 APPLE PARK WAY  
CUPERTINO, CA 95014, U.S.A.

**EUT DESCRIPTION:** SMARTPHONE

**MODEL:** A2341

**SERIAL NUMBER:** G6TCP01UQ5R9, G6TCM020Q5T6

**DATE TESTED:** MARCH 02, 2020 – AUGUST 13, 2020

APPLICABLE STANDARDS	
STANDARD	TEST RESULTS
CFR 47 Part 15 Subpart C	Complies
ISED RSS-247 Issue 2	Complies
ISED RSS-GEN Issue 5	Complies

UL Verification Services Inc. tested the above equipment in accordance with the requirements set forth in the above standards. The test results show that the equipment tested is capable of demonstrating compliance with the requirements as documented in this report.

The results documented in this report apply only to the tested sample, under the conditions and modes of operation as described herein. It is the manufacturer's responsibility to assure that additional production units of this model are manufactured with identical electrical and mechanical components. All samples tested were in good operating condition throughout the entire test program. Measurement Uncertainties are published for informational purposes only and were not taken into account unless noted otherwise.

This document may not be altered or revised in any way unless done so by UL Verification Services Inc. and all revisions are duly noted in the revisions section. Any alteration of this document not carried out by UL Verification Services Inc. will constitute fraud and shall nullify the document. This report must not be used by the client to claim product certification, approval, or endorsement by NVLAP, NIST, any agency of the Federal Government, or any agency of the U.S. government.

Approved & Released For  
UL Verification Services Inc. By:



Chin Pang  
Senior Engineer  
Consumer Technology Division  
UL Verification Services Inc.

Prepared By:

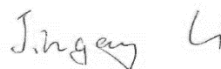

Jingang Li  
Test Engineer  
Consumer Technology Division  
UL Verification Services Inc.

## 2. TEST RESULTS SUMMARY

FCC Clause	ISED Clause	Requirement	Result	Comment
See Comment		Duty Cycle	Reporting purposes only	Per ANSI C63.10, Section 11.6.
See Comment	RSS-GEN 6.7	20dB BW/99% OBW	Reporting purposes only	ANSI C63.10 Sections 6.9.2 and 6.9.3
15.247 (a)(1)	RSS-247 (5.1) (b)	Hopping Frequency Separation	Complies	None.
15.247 (a)(1)(iii)	RSS-247 (5.1) (d)	Number of Hopping Channels	Complies	None.
15.247 (a)(1)(iii)	RSS-247 (5.1) (d)	Average Time of Occupancy	Complies	None.
15.247 (b)(1)	RSS-247 (5.4) (b)	Output Power	Complies	None.
See Comment		Average Power	Reporting purposes only	Per ANSI C63.10, Section 11.9.2.3.2.
15.247 (d)	RSS-247 (5.5)	Conducted Spurious Emissions	Complies	None.
15.209, 15.205	RSS-GEN 8.9, 8.10	Radiated Emissions	Complies	None.
15.207	RSS-Gen 8.8	AC Mains Conducted Emissions	Complies	None.

## 3. TEST METHODOLOGY

The tests documented in this report were performed in accordance with FCC CFR 47 Part 2, FCC CFR 47 Part 15, ANSI C63.10-2013, KDB 558074 D01 15.247 Meas Guidance v05r02, KDB 662911, RSS-GEN Issue 5, and RSS-247 Issue 2.

## 4. FACILITIES AND ACCREDITATION

The test sites and measurement facilities used to collect data are located at 47173 and 47266 Benicia Street, and 47658 Kato Road, Fremont, California, USA. Line conducted emissions are measured only at the 47173 address. The following table identifies which facilities were utilized for radiated emission measurements documented in this report. Specific facilities are also identified in the test results sections.

47173 Benicia Street	47266 Benicia Street	47658 Kato Rd.
<input type="checkbox"/> Chamber A (IC:2324B-1)	<input type="checkbox"/> Chamber D (IC:22541-1)	<input checked="" type="checkbox"/> Chamber I (IC: 2324A-5)
<input type="checkbox"/> Chamber B (IC:2324B-2)	<input checked="" type="checkbox"/> Chamber E (IC:22541-2)	<input type="checkbox"/> Chamber J (IC: 2324A-6)
<input type="checkbox"/> Chamber C (IC:2324B-3)	<input type="checkbox"/> Chamber F (IC:22541-3)	<input type="checkbox"/> Chamber K (IC: 2324A-1)
	<input checked="" type="checkbox"/> Chamber G (IC:22541-4)	<input type="checkbox"/> Chamber L (IC: 2324A-3)
	<input type="checkbox"/> Chamber H (IC:22541-5)	<input type="checkbox"/> Chamber M (IC: 2324A-2)

The above test sites and facilities are covered under FCC Test Firm Registration # 208313. Chambers above are covered under Industry Canada company address and respective code: 2324A.

UL Verification Services Inc. is accredited by NVLAP, Laboratory Code 200065-0



## 5. DECISION RULES AND MEASUREMENT UNCERTAINTY

### 5.1. METROLOGICAL TRACEABILITY

All test and measuring equipment utilized to perform the tests documented in this report are calibrated on a regular basis, with a maximum time between calibrations of one year or the manufacturers' recommendation, whichever is less, and where applicable is traceable to recognized national standards.

### 5.2. DECISION RULES

The Decision Rule is based on Simple Acceptance in accordance with ISO Guide 98-4:2012 Clause 8.2. (Measurement uncertainty is not taken into account when stating conformity with a specified requirement.)

### 5.3. MEASUREMENT UNCERTAINTY

Where relevant, the following measurement uncertainty levels have been estimated for tests performed on the apparatus:

PARAMETER	U <sub>Lab</sub>
Worst Case Conducted Disturbance, 9KHz to 0.15 MHz	3.39 dB
Worst Case Conducted Disturbance, 0.15 to 30 MHz	3.07 dB
Worst Case Radiated Disturbance, 9KHz to 30 MHz	2.52 dB
Worst Case Radiated Disturbance, 30 to 1000 MHz	4.88 dB
Worst Case Radiated Disturbance, 1000 to 18000 MHz	4.24 dB
Worst Case Radiated Disturbance, 18000 to 26000 MHz	4.37 dB
Worst Case Radiated Disturbance, 26000 to 40000 MHz	5.17 dB

Uncertainty figures are valid to a confidence level of 95%.

## 6. EQUIPMENT UNDER TEST

### 6.1. EUT DESCRIPTION

The Apple iPhone is a smartphone with multimedia functions (music, application support, and video), cellular GSM, GPRS, EGPRS, UMTS, LTE, 5G, CDMA, IEEE 802.11a/b/g/n/ac/ax, Bluetooth, Ultra-Wideband, GPS, NFC and WPT. All models support at least one UICC based SIM. The second SIM is either an UICC based p-SIM (physical SIM) or e-SIM (electronic SIM). The device supports a built-in inductive charging transmitter and receiver. The rechargeable battery is not user accessible.

### 6.2. MAXIMUM OUTPUT POWER

The transmitter has a maximum peak conducted output power as follows:

Antenna	Config	Frequency Range (MHz)	Mode	Output Power (dBm)	Output Power (mW)
ANT 4	High Power	2402 - 2480	Basic GFSK	20.20	104.71
		2402 - 2480	QPSK	18.29	67.45
		2402 - 2480	Enhanced 8PSK	18.40	69.18
	Low Power	2402 - 2480	Basic GFSK	12.99	19.91
		2402 - 2480	QPSK	11.39	13.77
		2402 - 2480	Enhanced 8PSK	11.59	14.42
ANT 3	High Power	2402 - 2480	Basic GFSK	20.16	103.75
		2402 - 2480	QPSK	18.34	68.23
		2402 - 2480	Enhanced 8PSK	18.42	69.50
	Low Power	2402 - 2480	Basic GFSK	12.93	19.63
		2402 - 2480	QPSK	11.20	13.18
		2402 - 2480	Enhanced 8PSK	11.32	13.55
BF, ANT 4 + ANT 3	High Power	2402 - 2480	Basic GFSK TxBF	20.72	118.03
		2402 - 2480	QPSK TxBF	20.11	102.57
		2402 - 2480	Enhanced 8PSK TxBF	20.21	104.95
	Low Power	2402 - 2480	Basic GFSK TxBF	15.91	38.99
		2402 - 2480	QPSK TxBF	14.28	26.79
		2402 - 2480	Enhanced 8PSK TxBF	14.40	27.54

Note: GFSK, DQPSK, 8PSK average Power are all investigated, The GFSK & 8PSK Power are the worst case. Testing is based on these modes to showing compliance

### 6.3. DESCRIPTION OF AVAILABLE ANTENNAS

Frequency Range (GHz)	ANT 4 (dBi)	ANT 3 (dBi)
2.4	-1.9	0.4

## **6.4. SOFTWARE AND FIRMWARE**

The EUT firmware installed during testing was 18.1.148.558

## **6.5. WORST-CASE CONFIGURATION AND MODE**

The EUT was investigated in three orthogonal orientations X, Y and Z on ANT 4 (Core 0) and ANT 3 (Core 1). It was determined that X (Flatbed) orientation was the worst-case orientation for ANT 4 and 2TX BF, and Z (Portrait) was the worst case for ANT 3.

Radiated band edge, harmonic, and spurious emissions from 1GHz to 18GHz were performed with the EUT set to transmit at highest power on Low/Middle/High channels.

Radiated emissions below 1GHz, 18-26GHz and power line conducted emissions were performed with the EUT transmits at the channel with the highest output power as worst-case scenario. There were no emissions found below 30MHz within 20dB of the limit.

For below 1GHz tests EUT was connected to AC power adapter as the worst case; and for above 1GHz, the worst-case configuration reported was tested with EUT only. There were no emissions found below 30MHz within 20dB of the limit. For AC line conducted emission, test was investigated with AC power adapter and with laptop.

For simultaneous transmission of multiple channels in the 2.4GHz BT and 5GHz bands, No noticeable emission was found.

Worst-case data rates as provided by the client were:

GFSK mode: DH5  
8PSK mode: 3-DH5  
Beamforming, GFSK, DH5  
Beamforming, 8PSK, 3-DH5

There are two vendors of the WiFi/Bluetooth radio modules: variant 1 and variant 2. The WiFi/Bluetooth radio modules have the same mechanical outline (e.g., the same package dimension and pin-out layout), use the same on-board antenna matching circuit, have an identical antenna structure, and are built and tested to conform to the same specifications and to operate within the same tolerances.

Baseline testing was performed on the two variants to determine the worst case on all conducted power and radiated emissions.

## 6.6. DESCRIPTION OF TEST SETUP

SUPPORT TEST EQUIPMENT						
Description	Manufacturer	Model	Serial Number	FCC ID/ DoC		
Laptop	Apple	A1989	C02YL3ZMJHC8	BCGA1989		
Laptop 61W USBC-C AC/DC adapter	Liteon Technology	A1718	C4N711404U3GN8RAW	NA		
EUT AC Adapter	Apple	A2305	D292365CDYADHLHC3	NA		
I/O CABLES (RF CONDUCTED TEST)						
Cable No.	Port	# of Identical Ports	Connector Type	Cable Type	Cable Length (m)	Remarks
1	Antenna	1	SMA	Un-shielded	0.2	To spectrum Analyzer
2	USB	1	USB	Shielded	1.0	N/A
3	AC	1	AC	Un-shielded	2	N/A
I/O CABLES (RF RADIATED TEST)						
Cable No.	Port	# of Identical Ports	Connector Type	Cable Type	Cable Length (m)	Remarks
1	AC	1	AC	Un-shielded	2	N/A
2	USB	1	USB	Un-shielded	1	N/A

### TEST SETUP

The EUT is connected to a test laptop during the tests. Test software exercised the radio card.

**SETUP DIAGRAM FOR CONDUCTED TESTS**

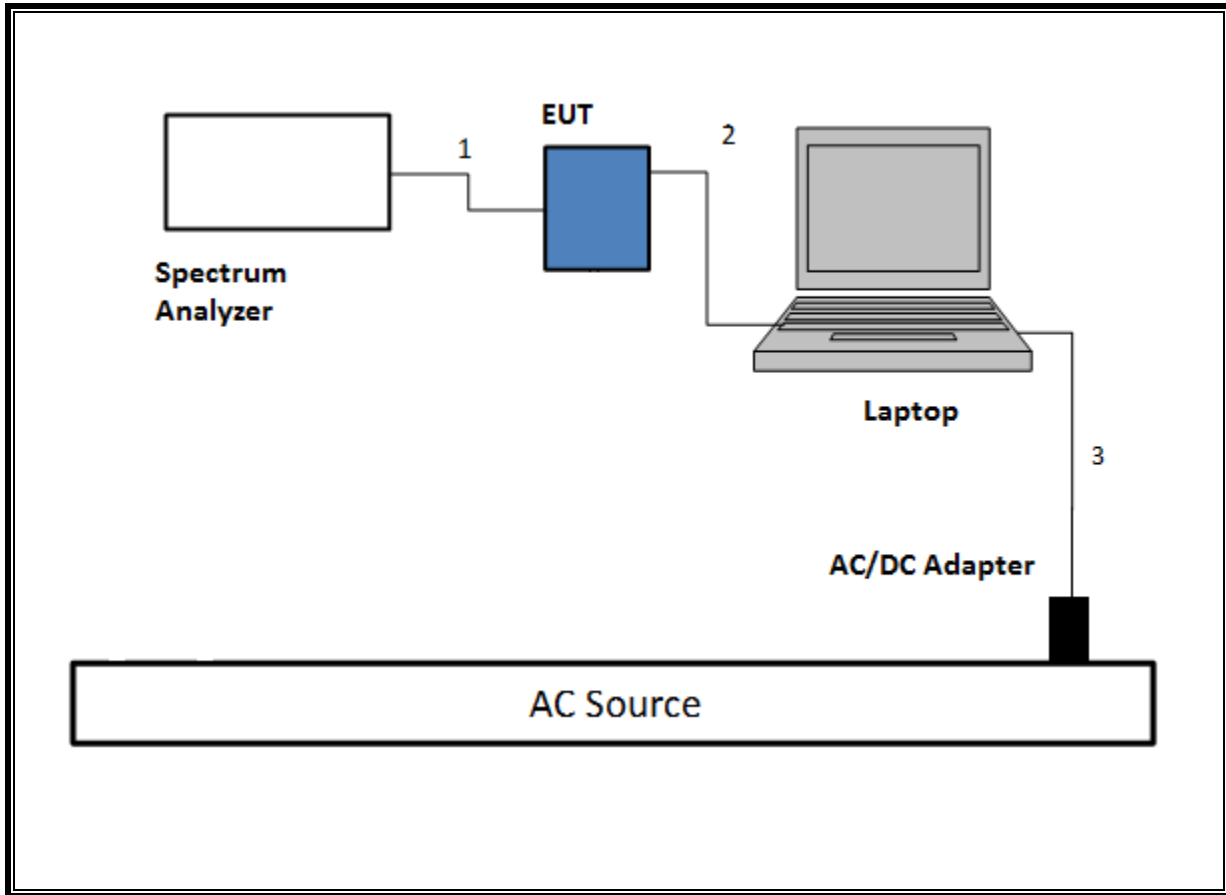

**SETUP DIAGRAM FOR RADIATED TESTS Above 1GHz**

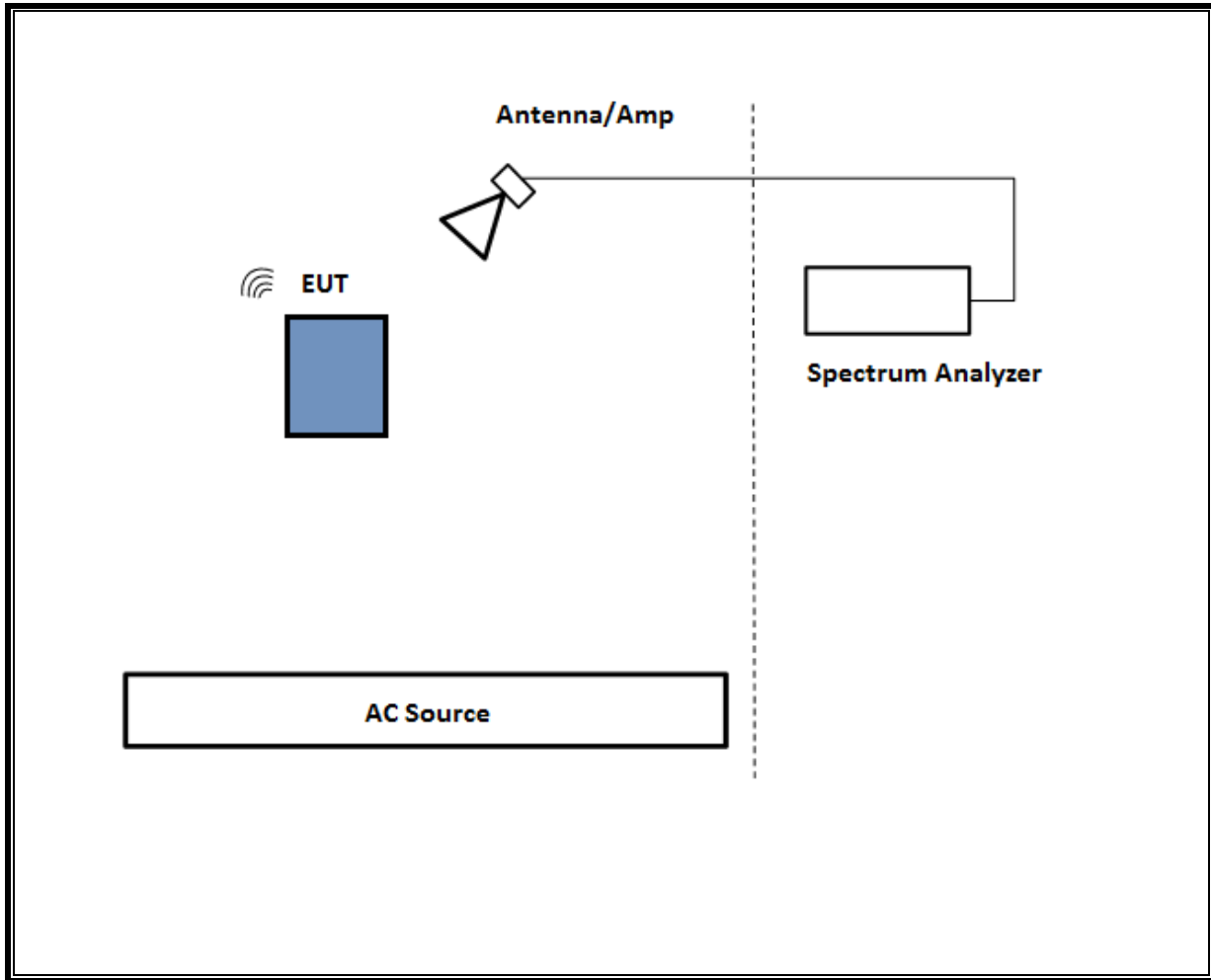

**SETUP DIAGRAM FOR Below 1GHz and AC LINE CONDUCTED TEST**

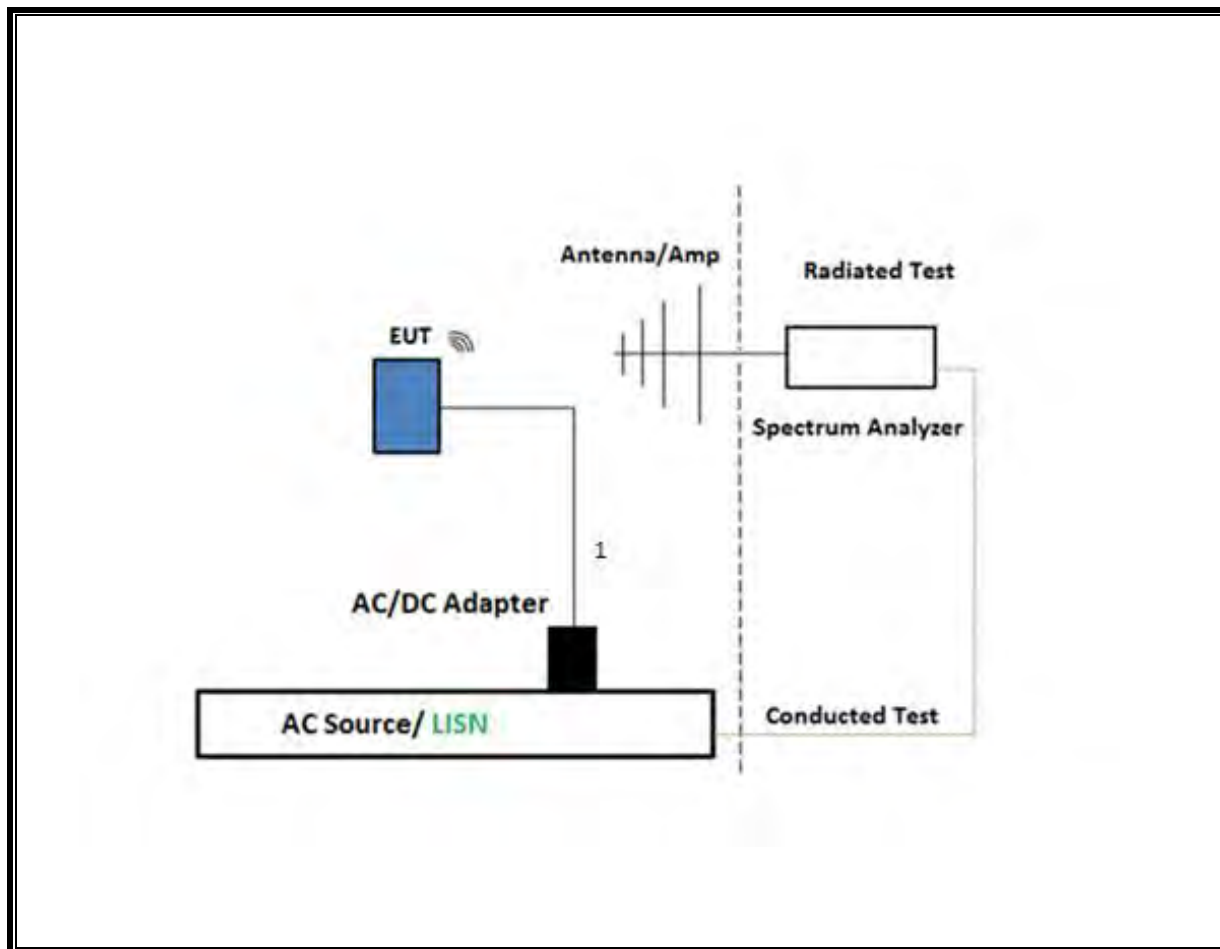

**TEST SETUP- AC LINE CONDUCTED: LAPTOP CONFIGURATION**

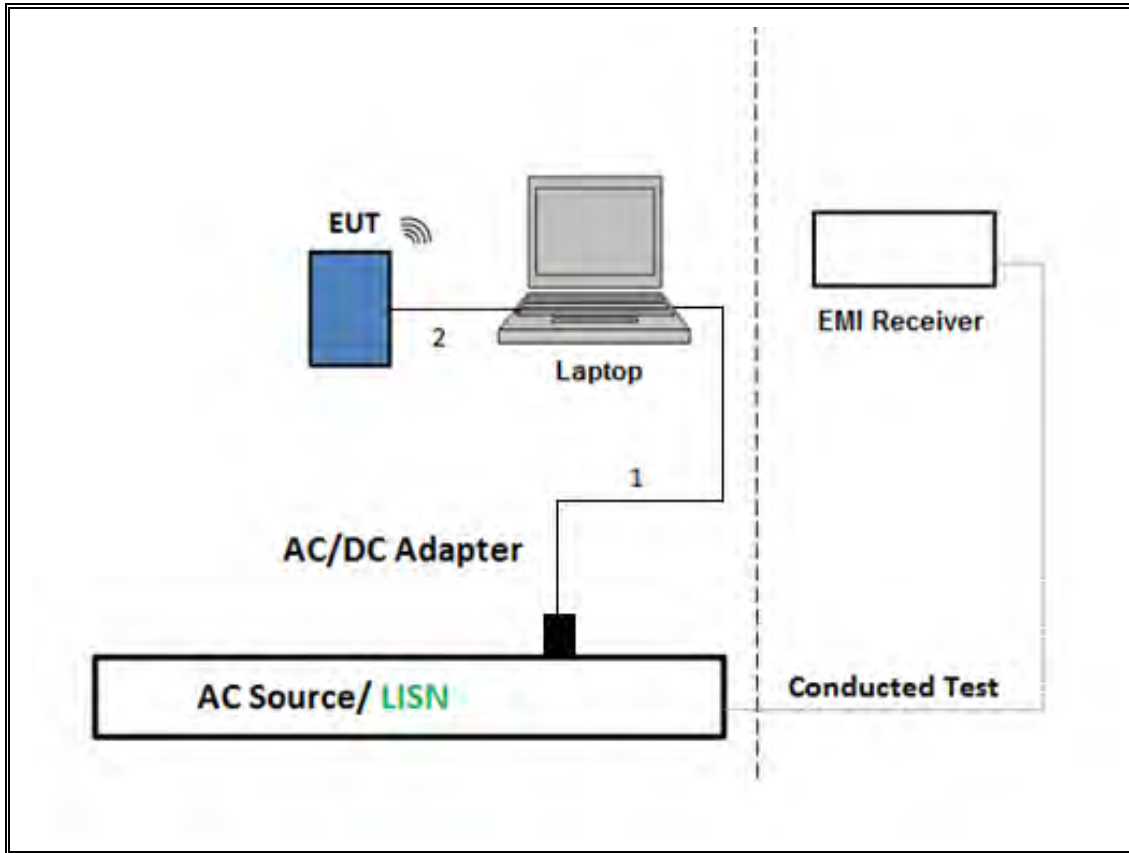



## 7. TEST AND MEASUREMENT EQUIPMENT

The following test and measurement equipment was utilized for the tests documented in this report:

TEST EQUIPMENT LIST					
Description	Manufacturer	Model	ID Num	Cal Due	Last Cal
*Antenna, Horn 1-18GHz	ETS Lindgren	3117	T862	08/20/2020	08/20/2019
Amplifier, 1 to 18GHz, 35dB	Amplical	AFS42-00101800-25-S-42	T1567	01/24/2021	01/24/2020
Antenna, Horn 1-18GHz	ETS Lindgren	3117	T712	03/09/2021	03/09/2020
RF Amplifier, 1-18GHz	MITEQ	AFS42-00101800-25-S-42	171460	08/24/2020	08/24/2019
Spectrum Analyzer, PXA, 3Hz to 44GHz	Keysight Technologies Inc	N9030A-544	T1210	01/22/2021	01/22/2020
Antenna, Horn 1-18GHz	ETS Lindgren	3117	T120	04/19/2021	04/19/2020
Amplifier, 1 to 18GHz	Miteq	AFS42-00101800-25-S-42	T491	06/12/2021	06/12/2020
Spectrum Analyzer, PXA, 3Hz to 44GHz	Keysight Technologies Inc	N9030A	T1466	01/23/2021	01/23/2020
*Amplifier, 10KHz to 1GHz, 32dB	Sonoma	310N	T173	06/06/2020	6/06/2019
EMI Test Receiver	Rohde & Schwarz	ESW44	Pre0179522	02/20/2021	02/20/2020
*Antenna, Broadband Hybrid, 30-2000MHz	Sunol Sciences	JB1	T130	08/09/2020	08/09/2019
Antenna Horn, 18 to 26GHz	ARA	SWH-28	T125	04/17/2021	04/17/2020
Pre-Amp 18-26GHz	Agilent Technology	8449B	T404	04/08/2021	04/08/2020
Spectrum Analyzer, PXA, 3Hz to 44GHz	Agilent (Keysight) Technologies	N9030A	T1454	01/23/2021	01/23/2020
Antenna, Active Loop 9KHz to 30MHz	ETS-Lindgren	6502	T757	10/01/2020	10/01/2019
Power Meter, P-series single channel	Keysight	N1911A	PRE0177682	01/21/2021	01/21/2020
Power Sensor	Keysight	N1921A	T1226	02/13/2021	02/13/2020

AC Line Conducted					
Description	Manufacturer	Model	ID Num	Cal Due	Last Cal
*EMI Test Receiver 9kHz-7GHz	Rohde & Schwarz	ESR	T1436	02/20/2021	02/20/2020
Power Cable, Line Conducted Emissions	UL	PR1	T861	10/27/2020	10/27/2019
LISN for Conducted Emissions CISPR-16	FISCHER CUSTOM COMMUNICATIONS	FCC-LISN-50/250-25-2-01	PRE0186446	01/23/2021	01/23/2020
UL AUTOMATION SOFTWARE					
Radiated Software	UL	UL EMC	Ver 9.5, Mar 6, 2020		
Conducted Software	UL	UL EMC	2020.2.26		
AC Line Conducted Software	UL	UL EMC	Ver 9.5, February 21, 2020		

\*Testing is completed before equipment expiration date.

## 8. MEASUREMENT METHODS

On Time and Duty Cycle: ANSI C63.10-2013 Section 11.6

Occupied BW (20dB): ANSI C63.10-2013 Section 6.9.2

Occupied BW (99%): ANSI C63.10-2013 Section 6.9.3

Carrier Frequency Separation: ANSI C63.10-2013 Section 7.8.2

Number of Hopping Frequencies: ANSI C63.10-2013 Section 7.8.3

Time of Occupancy (Dwell Time): ANSI C63.10-2013 Section 7.8.4

Peak Output Power: ANSI C63.10-2013 Section 7.8.5

Conducted Spurious Emissions: ANSI C63.10-2013 Section 7.8.8

Conducted Band-Edge: ANSI C63.10-2013 Section 6.10.4

Radiated Spurious Emissions Below 30MHz: ANSI C63.10-2013 Section 6.4 & 13

Radiated Spurious Emissions 30-1000MHz: ANSI C63.10-2013 Section 6.3, 6.5 & 13

Radiated Spurious Emissions above 1GHz: ANSI C63.10-2013 Section 6.3, 6.6 & 13

Radiated Band-edge: ANSI C63.10-2013 Section 6.10.5 & section 13

AC Power-line conducted emissions: ANSI C63.10-2013, Section 6.2.

## 9. ANTENNA PORT TEST RESULTS

### 9.1. ON TIME AND DUTY CYCLE

#### LIMITS

None; for reporting purposes only.

#### PROCEDURE

ANSI C63.10, Section 11.6 : Zero-Span Spectrum Analyzer Method.

#### ON TIME AND DUTY CYCLE RESULTS

Mode	ON Time B (msec)	Period (msec)	Duty Cycle x (linear)	Duty Cycle (%)	Duty Cycle Correction Factor (dB)	1/T Minimum VBW (kHz)
Bluetooth GFSK	100.00	100.00	1.000	100.0	0.00	0.010
Bluetooth 8PSK	100.00	100.00	1.000	100.0	0.00	0.010

Note: Low power duty cycle is same as high power

#### DUTY CYCLE PLOTS



BLUETOOTH GFSK



BLUETOOTH 8PSK

## **9.2. 20 dB AND 99% BANDWIDTH**

### **LIMITS**

None; for reporting purposes only.

### **TEST PROCEDURE**

The transmitter output is connected to a spectrum analyzer. The RBW is set to  $\geq 1\%$  of the 20 dB bandwidth. The VBW is set to 3x RBW. The sweep time is coupled.

### **RESULTS**

Only High Power modes result is reported, it covers all Low Power modes. Only Mid channel plot is reported to show setting parameter complies with testing method/procedure.

### 9.2.1. HIGH POWER BASIC DATA RATE GFSK MODULATION

**ANT 4**

Channel	Frequency (MHz)	20dB Bandwidth (MHz)	99% Bandwidth (MHz)
Low	2402	0.875	0.872
Mid	2441	0.877	0.875
High	2480	0.925	0.875

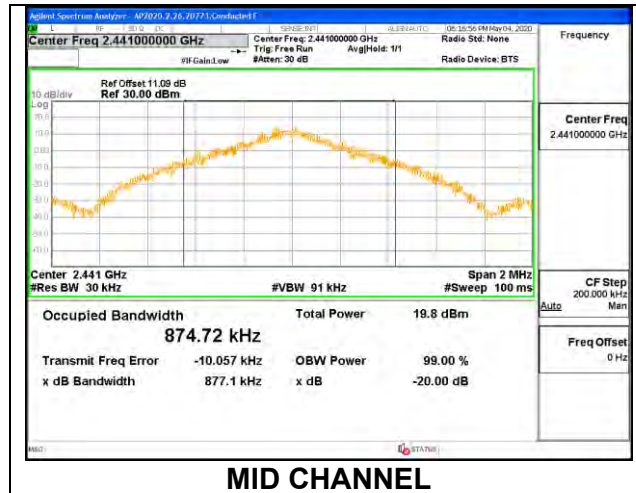

**ANT 3**

Channel	Frequency (MHz)	20dB Bandwidth (MHz)	99% Bandwidth (MHz)
Low	2402	0.926	0.875
Mid	2441	0.873	0.875
High	2480	0.873	0.873

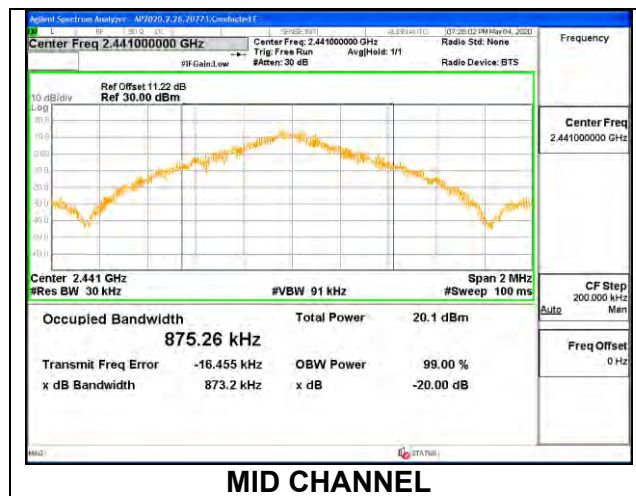

## 9.2.2. HIGH POWER ENHANCED DATA RATE 8PSK MODULATION

### ANT 4

Channel	Frequency (MHz)	20dB Bandwidth (MHz)	99% Bandwidth (MHz)
Low	2402	1.353	1.212
Mid	2441	1.350	1.210
High	2480	1.382	1.228

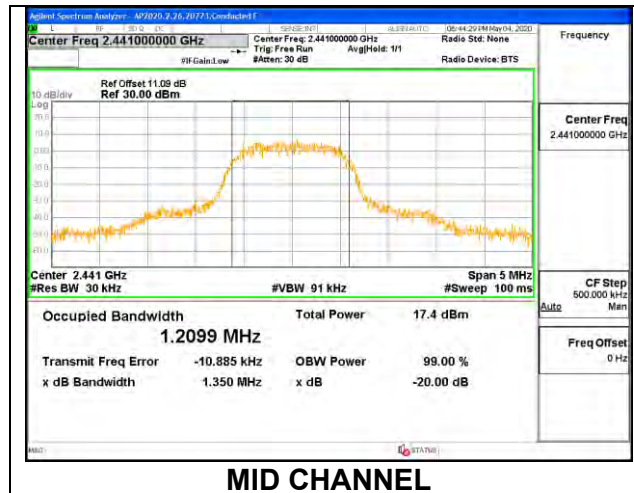

### ANT 3

Channel	Frequency (MHz)	20dB Bandwidth (MHz)	99% Bandwidth (MHz)
Low	2402	1.377	1.218
Mid	2441	1.362	1.216
High	2480	1.376	1.223

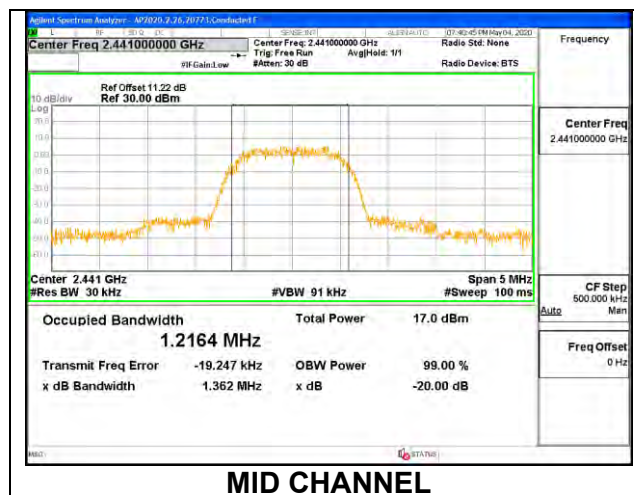

### 9.2.3. HIGH POWER BASIC DATA RATE TXBF GFSK MODULATION

#### 2TX ANT 4 + ANT 3 TxBF MODE

Channel	Frequency (MHz)	20dB Bandwidth Antenna 4 (MHz)	99% Bandwidth Antenna 4 (MHz)	20dB Bandwidth Antenna 3 (MHz)	99% Bandwidth Antenna 3 (MHz)
Low	2402	0.883	0.873	0.927	0.874
Mid	2441	0.883	0.873	0.927	0.873
High	2480	0.873	0.874	0.874	0.872

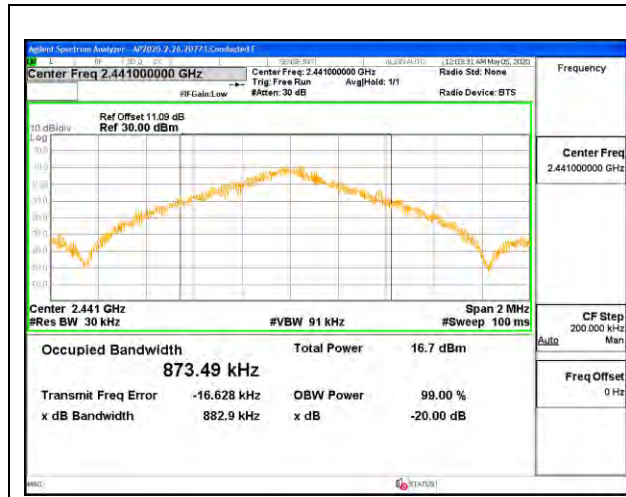

**MID CHANNEL ANT 4**

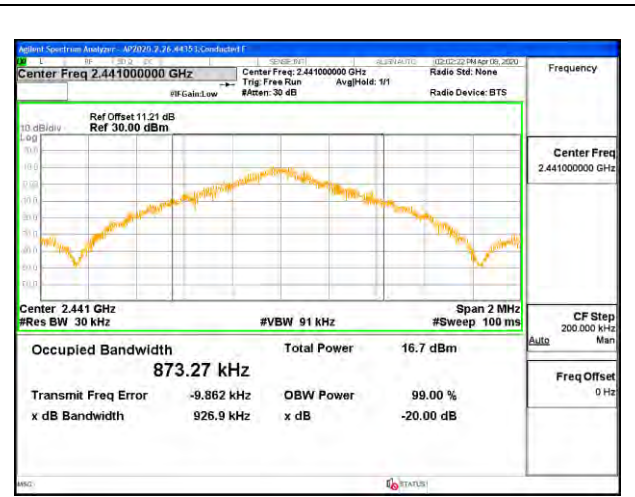

**MID CHANNEL ANT 3**

## 9.2.4. HIGH POWER ENHANCED DATA RATE TXBF 8PSK MODULATION

### 2TX ANT 4 + ANT 3 TxBF MODE

Channel	Frequency (MHz)	20dB Bandwidth Antenna 4 (MHz)	99% Bandwidth Antenna 4 (MHz)	20dB Bandwidth Antenna 3 (MHz)	99% Bandwidth Antenna 3 (MHz)
Low	2402	1.368	1.210	1.356	1.212
Mid	2441	1.354	1.211	1.369	1.212
High	2480	1.350	1.215	1.369	1.214

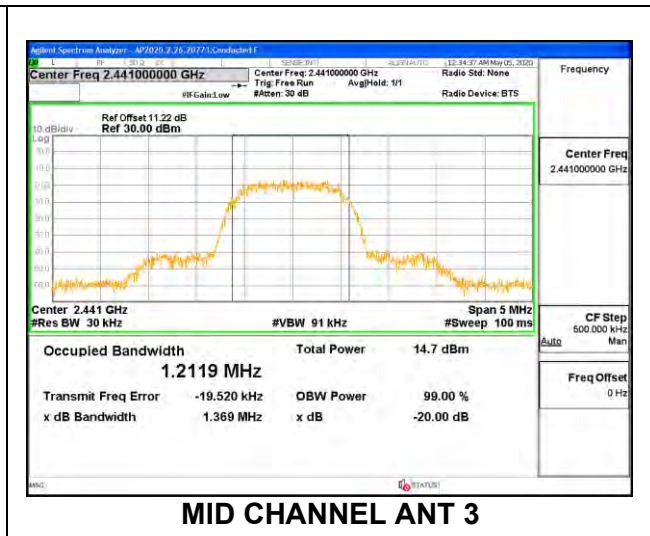
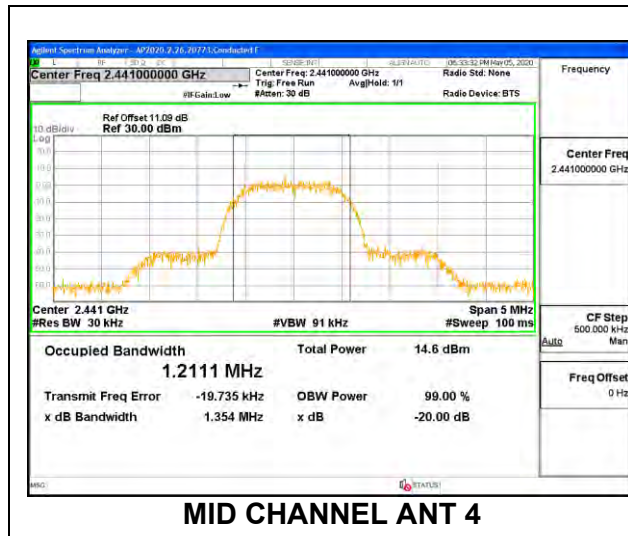



### 9.3. HOPPING FREQUENCY SEPARATION

#### LIMITS

FCC §15.247 (a) (1)

RSS-247 (5.1) (b)

Frequency hopping systems shall have hopping channel carrier frequencies separated by a minimum of 25 kHz or the 20 dB bandwidth of the hopping channel, whichever is greater.

Alternatively, frequency hopping systems operating in the 2400-2483.5 MHz band may have hopping channel carrier frequencies that are separated by 25 kHz or two-thirds of the 20 dB bandwidth of the hopping channel, whichever is greater, provided the systems operate with an output power no greater than 125 mW.

#### TEST PROCEDURE

The transmitter output is connected to a spectrum analyzer. The RBW is set to 300 kHz and the VBW is set to VBW = 3x RBW. The sweep time is coupled.

#### RESULTS

Only High Power GFSK mode result is reported since EDR (QPSK/8PSK) has exact same channel plan.

#### 9.3.1. HIGH POWER BASIC DATA RATE GFSK MODULATION

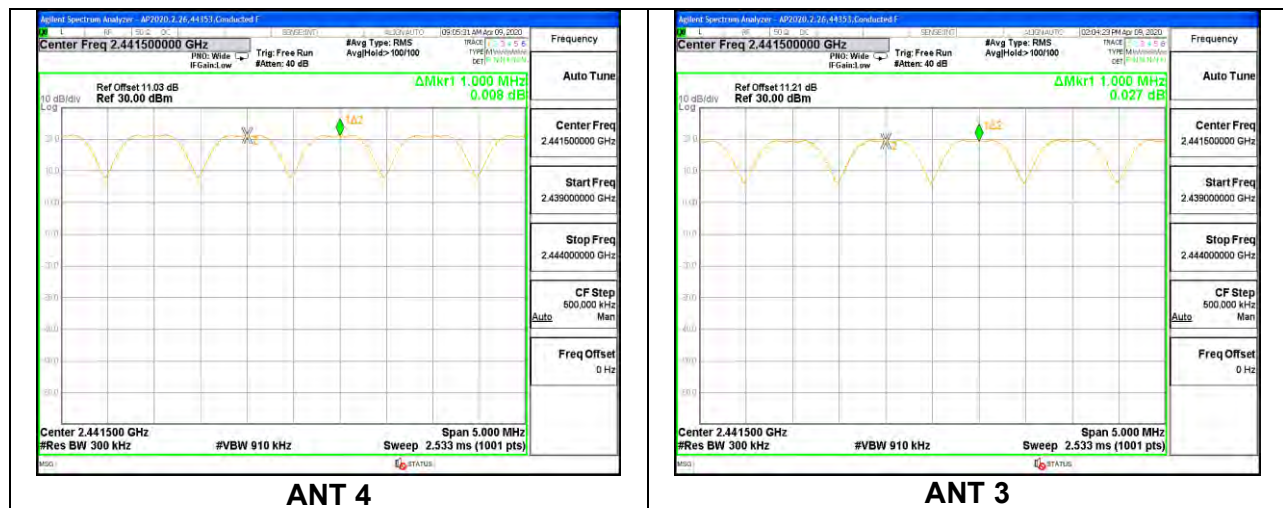

## **9.4. NUMBER OF HOPPING CHANNELS**

### **LIMITS**

FCC §15.247 (a) (1) (iii)

RSS-247 (5.1) (d)

Frequency hopping systems in the 2400 – 2483.5 MHz band shall use at least 15 non-overlapping channels.

### **TEST PROCEDURE**

The transmitter output is connected to a spectrum analyzer. The span is set to cover the entire authorized band, in either a single sweep or in multiple contiguous sweeps. The RBW is set to a maximum of 1 % of the span. The analyzer is set to Max Hold.

### **RESULTS**

Normal Mode: 79 Channels Observed. Only High Power GFSK mode result is reported since EDR (QPSK/8PSK) has exact same channel plan.

### 9.4.1. HIGH POWER BASIC DATA RATE GFSK MODULATION

#### ANT 4



100MHz SPAN



30MHz SPAN, SEGMENT 1 OF 3



30MHz SPAN, SEGMENT 2 OF 3

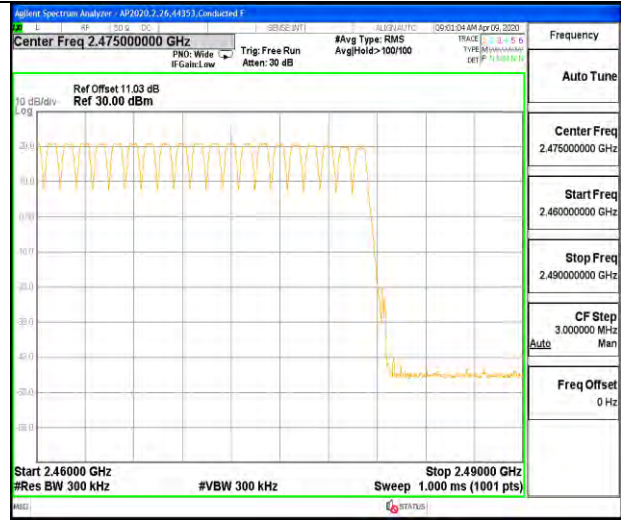

30MHz SPAN, SEGMENT 3 OF 3

**ANT 3**

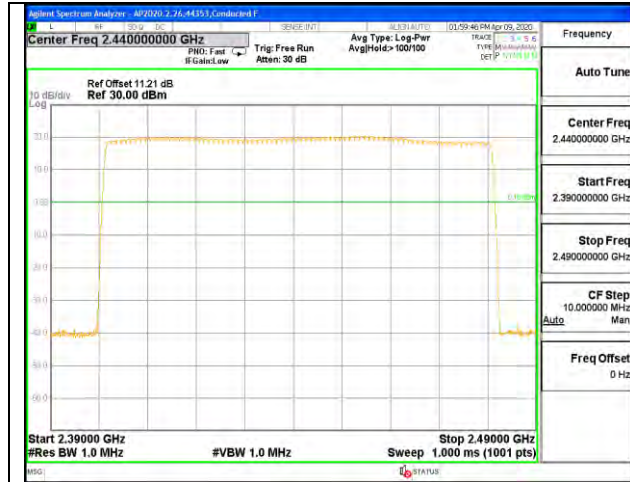

**100MHz SPAN**

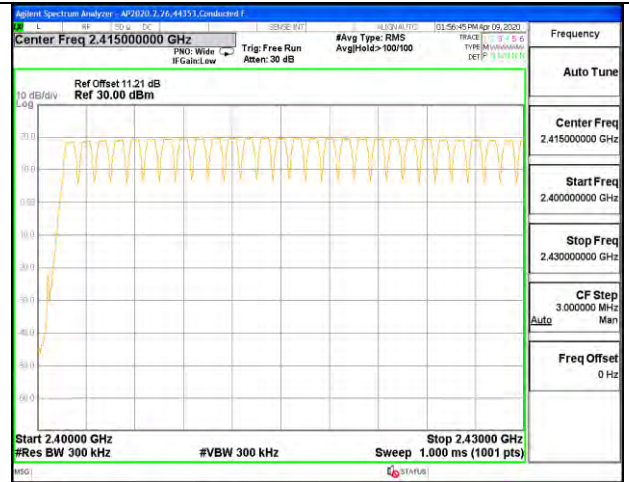

**30MHz SPAN, SEGMENT 1 OF 3**

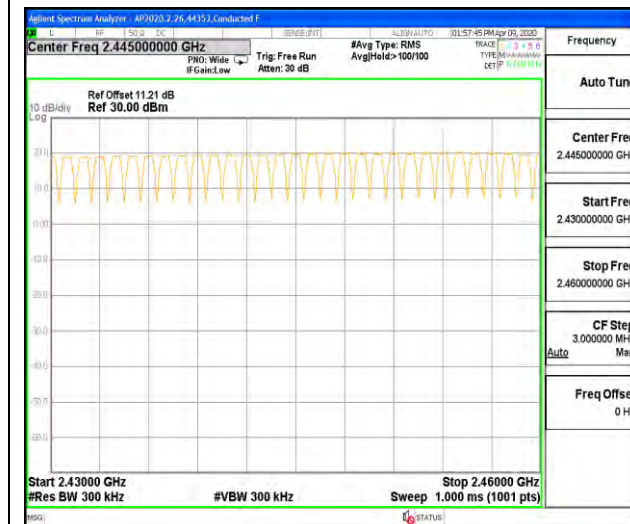

**30MHz SPAN, SEGMENT 2 OF 3**

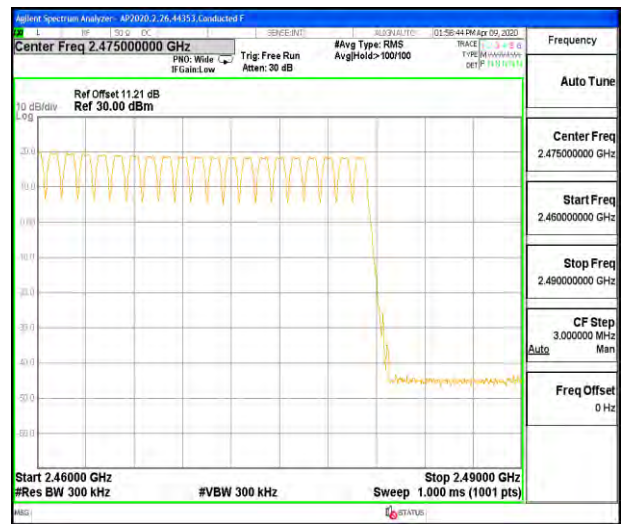

**30MHz SPAN, SEGMENT 3 OF 3**

## **9.5. AVERAGE TIME OF OCCUPANCY**

### **LIMITS**

FCC §15.247 (a) (1) (iii)

RSS-247 (5.1) (d)

The average time of occupancy on any channel shall not be greater than 0.4 seconds within a period of 0.4 seconds multiplied by the number of hopping channels employed.

### **TEST PROCEDURE**

The transmitter output is connected to a spectrum analyzer. The span is set to 0 Hz, centered on a single, selected hopping channel. The width of a single pulse is measured in a fast scan. The number of pulses is measured in a 3.16 second scan, to enable resolution of each occurrence.

The average time of occupancy in the specified 3.16 second period (79 channels \* 0.4 s) is equal to  $10 * (\# \text{ of pulses in } 3.16 \text{ s}) * \text{ pulse width}$ .

For AFH mode, the average time of occupancy in the specified 8 second period (20 channels \* 0.4 seconds) is equal to  $10 * (\# \text{ of pulses in } 0.8 \text{ s}) * \text{ pulse width}$ .

### **RESULTS**

Only High Power GFSK mode result is reported since EDR (QPSK/8PSK) has exact same timing.

### 9.5.1. HIGH POWER BASIC DATA RATE GFSK MODULATION

**ANT 4**

DH Packet	Pulse Width (msec)	Number of Pulses in 3.16 seconds	Average Time of Occupancy (sec)	Limit (sec)	Margin (sec)
GFSK Normal Mode					
DH1	0.379	32	0.1213	0.4	-0.2787
DH3	1.632	15	0.2448	0.4	-0.1552
DH5	2.876	9	0.2588	0.4	-0.1412
DH Packet	Pulse Width (sec)	Number of Pulses in 0.8 seconds	Average Time of Occupancy (sec)	Limit (sec)	Margin (sec)
GFSK AFH Mode					
DH1	0.379	8	0.03032	0.4	-0.3697
DH3	1.632	3.75	0.06120	0.4	-0.3388
DH5	2.876	2.25	0.06471	0.4	-0.3353

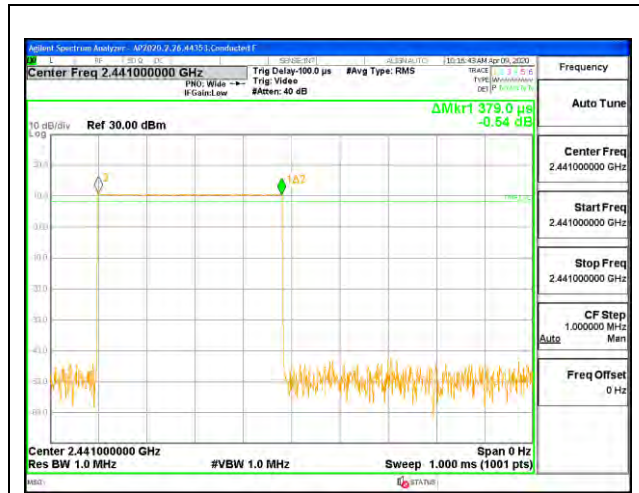

**PULSE WIDTH – DH1**



**PULSE WIDTH – DH3**

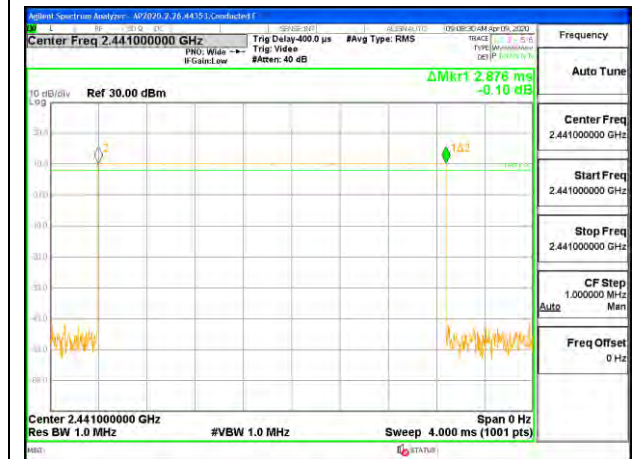

**PULSE WIDTH – DH5**

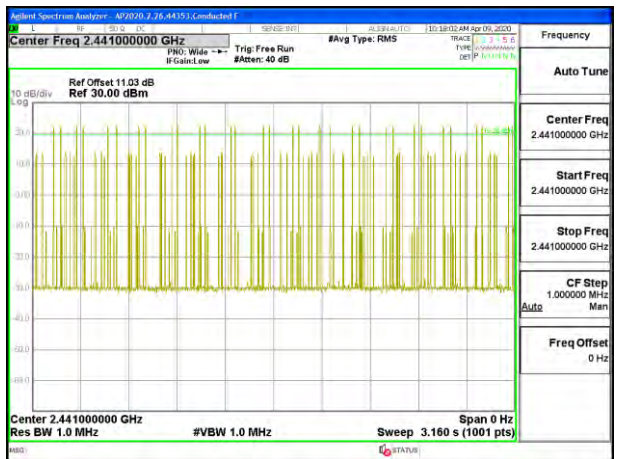

**NUMBER OF PULSES IN 3.16 SECOND OBSERVATION PERIOD – DH1**

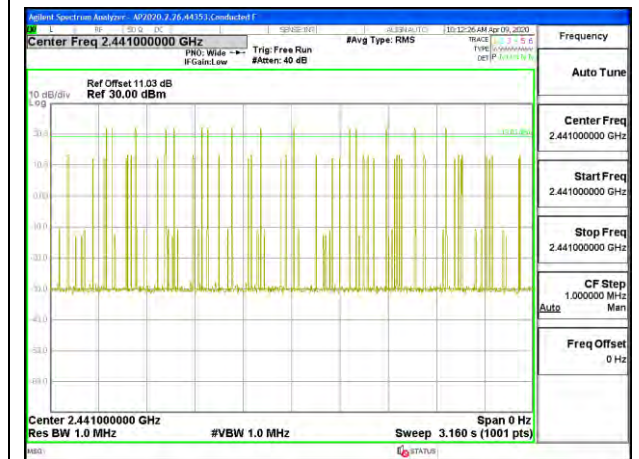

**NUMBER OF PULSES IN 3.16 SECOND OBSERVATION PERIOD – DH3**

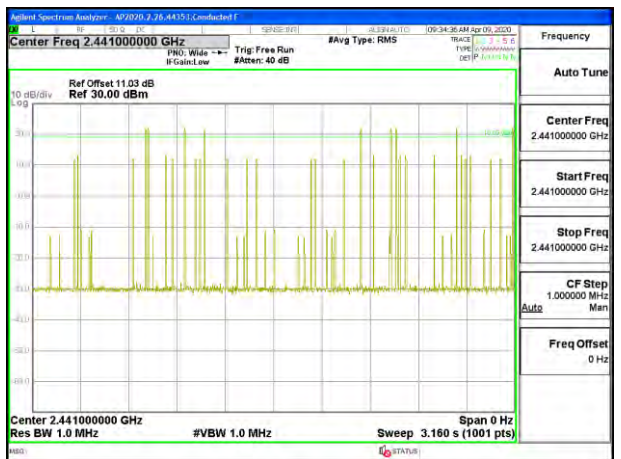

**NUMBER OF PULSES IN 3.16 SECOND OBSERVATION PERIOD – DH5**

**ANT 3**

DH Packet	Pulse Width (msec)	Number of Pulses in 3.16 seconds	Average Time of Occupancy (sec)	Limit (sec)	Margin (sec)
GFSK Normal Mode					
DH1	0.38	32	0.1216	0.4	-0.2784
DH3	1.632	16	0.2611	0.4	-0.1389
DH5	2.872	10	0.2872	0.4	-0.1128
DH Packet	Pulse Width (sec)	Number of Pulses in 0.8 seconds	Average Time of Occupancy (sec)	Limit (sec)	Margin (sec)
GFSK AFH Mode					
DH1	0.38	8	0.03040	0.4	-0.3696
DH3	1.632	4	0.06528	0.4	-0.3347
DH5	2.872	2.5	0.07180	0.4	-0.3282



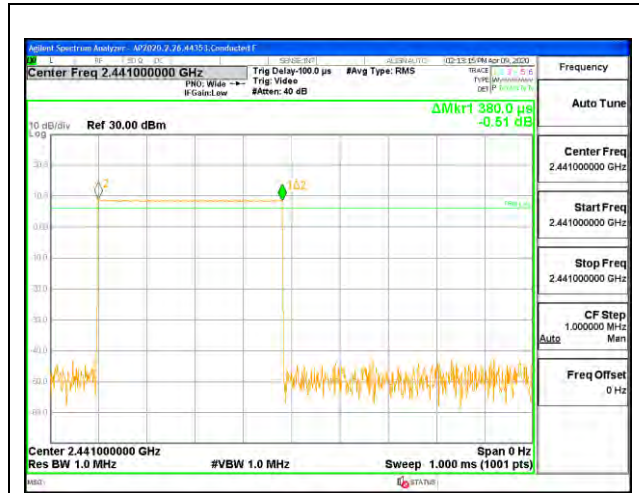

**PULSE WIDTH – DH1**

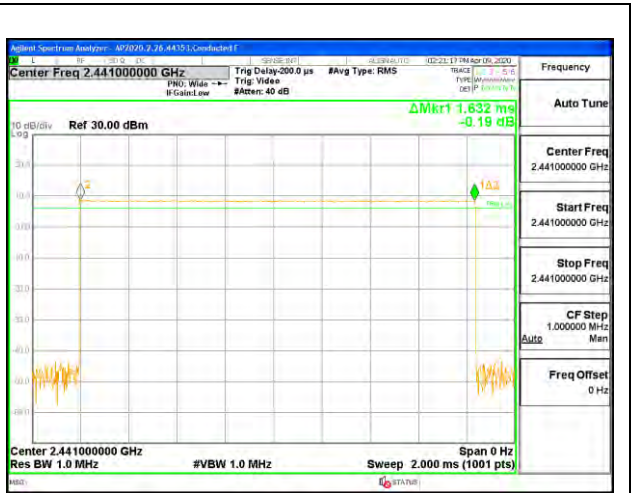

**PULSE WIDTH – DH3**



**PULSE WIDTH – DH5**



**NUMBER OF PULSES IN 3.16 SECOND  
OBSERVATION PERIOD – DH1**

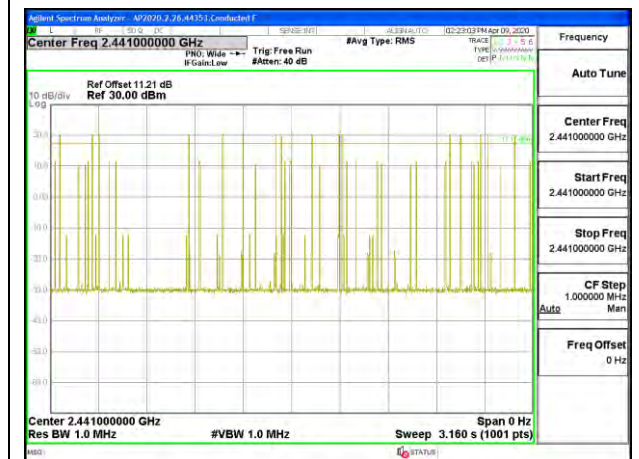

**NUMBER OF PULSES IN 3.16 SECOND  
OBSERVATION PERIOD – DH3**



**NUMBER OF PULSES IN 3.16 SECOND  
OBSERVATION PERIOD – DH5**

## 9.6. OUTPUT POWER

### LIMITS

§15.247 (b) (1)

RSS-247 (5.4) (b)

The maximum antenna gain is less than 6 dBi, therefore the limit is 30 dBm. Alternatively, frequency hopping systems operating in the 2400-2483.5 MHz band may have hopping channel carrier frequencies that are separated by 25 kHz or two-thirds of the 20 dB bandwidth of the hopping channel, whichever is greater, provided the systems operate with an output power no greater than 125 mW.

For frequency hopping systems operating in the 2400-2483.5 MHz band employing at least 75 non-overlapping hopping channels, and all frequency hopping systems in the 5725-5850 MHz band: 1 watt. For all other frequency hopping systems in the 2400-2483.5 MHz band: 0.125 watts

### TEST PROCEDURE

Measurements perform using a wideband gated RF power meter.

The cable assembly insertion loss of 10.5 dB (including 10 dB pad and 0.5 dB cable) was entered as an offset in the power meter to allow for a gated average reading of power.

### DIRECTIONAL ANTENNA GAIN

For 1 TX:

There is only one transmitter output therefore the directional gain is equal to the antenna gain.

For 2 TX:

Tx chains are correlated for power due to the device supporting Beamforming. The directional gains are as follows:

Band (GHz)	ANT 4 Antenna Gain (dBi)	ANT 3 Antenna Gain (dBi)	Uncorrelated Chains Directional Gain (dBi)	Correlated Chains Directional Gain (dBi)
2.4	-1.90	0.40	-0.60	2.34

### RESULTS

### 9.6.1. HIGH POWER BASIC DATA RATE GFSK MODULATION

**ANT 4**

Tested By:	20773
Date:	7/27/2020

Channel	Frequency (MHz)	Output Power (dBm)	Limit (dBm)	Margin (dB)
Low	2402	20.05	21	-0.95
Middle	2441	20.20	21	-0.8
High	2480	20.16	21	-0.84

**ANT 3**

Tested By:	20773
Date:	7/27/2020

Channel	Frequency (MHz)	Output Power (dBm)	Limit (dBm)	Margin (dB)
Low	2402	20.02	21	-0.98
Middle	2441	20.16	21	-0.84
High	2480	20.12	21	-0.88

### 9.6.2. HIGH POWER ENHANCED DATA RATE QPSK MODULATION

**ANT 4**

Tested By:	20773
Date:	7/27/2020

Channel	Frequency (MHz)	Output Power (dBm)	Limit (dBm)	Margin (dB)
Low	2402	18.22	21	-2.78
Middle	2441	18.29	21	-2.71
High	2480	18.19	21	-2.81

**ANT 3**

Tested By:	20773
Date:	7/27/2020

Channel	Frequency (MHz)	Output Power (dBm)	Limit (dBm)	Margin (dB)
Low	2402	18.34	21	-2.66
Middle	2441	18.32	21	-2.68
High	2480	18.21	21	-2.79

### 9.6.3. HIGH POWER ENHANCED DATA RATE 8PSK MODULATION

#### ANT 4

Tested By:	20773
Date:	7/27/2020

Channel	Frequency (MHz)	Output Power (dBm)	Limit (dBm)	Margin (dB)
Low	2402	18.29	21	-2.71
Middle	2441	18.40	21	-2.6
High	2480	18.26	21	-2.74

#### ANT 3

Tested By:	20773
Date:	7/27/2020

Channel	Frequency (MHz)	Output Power (dBm)	Limit (dBm)	Margin (dB)
Low	2402	18.37	21	-2.63
Middle	2441	18.42	21	-2.58
High	2480	19.39	21	-1.61

### 9.6.4. LOW POWER BASIC DATA RATE GFSK MODULATION

#### ANT 4

Tested By:	20773
Date:	7/27/2020

Channel	Frequency (MHz)	Output Power (dBm)	Limit (dBm)	Margin (dB)
Low	2402	12.92	21	-8.08
Middle	2441	12.99	21	-8.01
High	2480	12.95	21	-8.05

#### ANT 3

Tested By:	20773
Date:	7/27/2020

Channel	Frequency (MHz)	Output Power (dBm)	Limit (dBm)	Margin (dB)
Low	2402	12.86	21	-8.14
Middle	2441	12.93	21	-8.07
High	2480	12.82	21	-8.18

### 9.6.5. LOW POWER ENHANCED DATA RATE QPSK MODULATION

#### ANT 4

Tested By:	20773
Date:	7/27/2020

Channel	Frequency (MHz)	Output Power (dBm)	Limit (dBm)	Margin (dB)
Low	2402	11.13	21	-9.87
Middle	2441	11.39	21	-9.61
High	2480	11.26	21	-9.74

#### ANT 3

Tested By:	20773
Date:	7/27/2020

Channel	Frequency (MHz)	Output Power (dBm)	Limit (dBm)	Margin (dB)
Low	2402	11.12	21	-9.88
Middle	2441	11.20	21	-9.8
High	2480	11.13	21	-9.87

### 9.6.6. LOW POWER ENHANCED DATA RATE 8PSK MODULATION

#### ANT 4

Tested By:	20773
Date:	7/27/2020

Channel	Frequency (MHz)	Output Power (dBm)	Limit (dBm)	Margin (dB)
Low	2402	11.32	21	-9.68
Middle	2441	11.59	21	-9.41
High	2480	11.23	21	-9.77

#### ANT 3

Tested By:	20773
Date:	7/27/2020

Channel	Frequency (MHz)	Output Power (dBm)	Limit (dBm)	Margin (dB)
Low	2402	11.29	21	-9.71
Middle	2441	11.32	21	-9.68
High	2480	11.20	21	-9.8

### 9.6.7. HIGH POWER BASIC DATA RATE TXBF GFSK MODULATION

#### 2TX ANT 4 + ANT 3 TxBF Mode

Tested By:	20773
Date:	7/27/2020

Channel	Frequency (MHz)	Output Power ANT 4 (dBm)	Output Power ANT 3 (dBm)	Total Power (dBm)	Limit (dBm)	Margin (dB)
Low	2402	17.66	17.58	20.63	21	-0.37
Middle	2441	17.74	17.68	20.72	21	-0.28
High	2480	17.69	17.56	20.64	21	-0.36

### 9.6.8. HIGH POWER ENHANCED DATA RATE TXBF QPSK MODULATION

#### 2TX ANT 4 + ANT 3 TxBF Mode

Tested By:	20773
Date:	7/27/2020

Channel	Frequency (MHz)	Output Power ANT 4 (dBm)	Output Power ANT 3 (dBm)	Total Power (dBm)	Limit (dBm)	Margin (dB)
Low	2402	17.02	17.04	20.04	21	-0.96
Middle	2441	17.07	17.12	20.11	21	-0.89
High	2480	17.05	17.08	20.08	21	-0.92

### 9.6.9. HIGH POWER ENHANCED DATA RATE TXBF 8PSK MODULATION

#### 2TX ANT 4 + ANT 3 TxBF Mode

Tested By:	20773
Date:	7/27/2020

Channel	Frequency (MHz)	Output Power ANT 4 (dBm)	Output Power ANT 3 (dBm)	Total Power (dBm)	Limit (dBm)	Margin (dB)
Low	2402	17.12	17.20	20.17	21	-0.83
Middle	2441	17.15	17.25	20.21	21	-0.79
High	2480	17.19	17.18	20.20	21	-0.80

### 9.6.10. LOW POWER BASIC DATA RATE TXBF GFSK MODULATION

**2TX ANT 4 + ANT 3 TxBF Mode**

Tested By:	20773
Date:	7/27/2020

Channel	Frequency (MHz)	Output Power ANT 4 (dBm)	Output Power ANT 3 (dBm)	Total Power (dBm)	Limit (dBm)	Margin (dB)
Low	2402	12.71	12.89	15.81	21	-5.19
Middle	2441	12.87	12.92	15.91	21	-5.09
High	2480	12.96	12.91	15.95	21	-5.05

### 9.6.11. LOW POWER ENHANCED DATA RATE TXBF QPSK MODULATION

**2TX ANT 4 + ANT 3 TxBF Mode**

Tested By:	20773
Date:	7/27/2020

Channel	Frequency (MHz)	Output Power ANT 4 (dBm)	Output Power ANT 3 (dBm)	Total Power (dBm)	Limit (dBm)	Margin (dB)
Low	2402	11.22	11.18	14.21	21	-6.79
Middle	2441	11.24	11.28	14.27	21	-6.73
High	2480	11.32	11.21	14.28	21	-6.72

### 9.6.12. LOW POWER ENHANCED DATA RATE TXBF 8PSK MODULATION

**2TX ANT 4 + ANT 3 TxBF Mode**

Tested By:	20773
Date:	7/27/2020

Channel	Frequency (MHz)	Output Power ANT 4 (dBm)	Output Power ANT 3 (dBm)	Total Power (dBm)	Limit (dBm)	Margin (dB)
Low	2402	11.43	11.31	14.38	21	-6.62
Middle	2441	11.37	11.41	14.40	21	-6.60
High	2480	11.26	11.35	14.32	21	-6.68

## **9.7. AVERAGE POWER**

### **LIMITS**

None; for reporting purposes only

### **TEST PROCEDURE**

Measurements perform using a wideband gated RF power meter.

The cable assembly insertion loss of 10.5 dB (including 10 dB pad and 0.5 dB cable) was entered as an offset in the power meter to allow for a gated average reading of power.

### **RESULTS**



### 9.7.1. HIGH POWER BASIC DATA RATE GFSK MODULATION

#### ANT 4

Tested By:	20773
Date	7/27/2020

Channel	Frequency (MHz)	Average Power (dBm)
Low	2402	19.75
Middle	2441	19.91
High	2480	19.86

#### ANT 3

Tested By:	20773
Date	7/27/2020

Channel	Frequency (MHz)	Average Power (dBm)
Low	2402	19.72
Middle	2441	19.86
High	2480	19.82

### 9.7.2. HIGH POWER ENHANCED DATA RATE QPSK MODULATION

#### ANT 4

Tested By:	20773
Date	7/27/2020

Channel	Frequency (MHz)	Average Power (dBm)
Low	2402	15.72
Middle	2441	15.78
High	2480	15.69

#### ANT 3

Tested By:	20773
Date	7/27/2020

Channel	Frequency (MHz)	Average Power (dBm)
Low	2402	15.75
Middle	2441	15.82
High	2480	15.72

### 9.7.3. HIGH POWER ENHANCED DATA RATE 8PSK MODULATION

**ANT 4**

Tested By:	20773
Date	7/27/2020

Channel	Frequency (MHz)	Average Power (dBm)
Low	2402	15.76
Middle	2441	15.88
High	2480	15.73

**ANT 3**

Tested By:	20773
Date	7/27/2020

Channel	Frequency (MHz)	Average Power (dBm)
Low	2402	15.85
Middle	2441	15.89
High	2480	15.86

### 9.7.4. LOW POWER BASIC DATA RATE GFSK MODULATION

**ANT 4**

Tested By:	20773
Date	7/27/2020

Channel	Frequency (MHz)	Average Power (dBm)
Low	2402	12.18
Middle	2441	12.44
High	2480	12.31

**ANT 3**

Tested By:	20773
Date	7/27/2020

Channel	Frequency (MHz)	Average Power (dBm)
Low	2402	12.24
Middle	2441	12.46
High	2480	12.38

### 9.7.5. LOW POWER ENHANCED DATA RATE QPSK MODULATION

**ANT 4**

Tested By:	20773
Date	7/27/2020

Channel	Frequency (MHz)	Average Power (dBm)
Low	2402	8.56
Middle	2441	8.60
High	2480	8.58

**ANT 3**

Tested By:	20773
Date	7/27/2020

Channel	Frequency (MHz)	Average Power (dBm)
Low	2402	8.55
Middle	2441	8.59
High	2480	8.57

### 9.7.6. LOW POWER ENHANCED DATA RATE 8PSK MODULATION

**ANT 4**

Tested By:	20773
Date	7/27/2020

Channel	Frequency (MHz)	Average Power (dBm)
Low	2402	8.89
Middle	2441	8.92
High	2480	8.79

**ANT 3**

Tested By:	20773
Date	7/27/2020

Channel	Frequency (MHz)	Average Power (dBm)
Low	2402	8.82
Middle	2441	8.86
High	2480	8.77

### 9.7.7. HIGH POWER BASIC DATA RATE TXBF GFSK MODULATION

#### 2TX ANT 4 + ANT 3 TxBF Mode

Tested By:	20773
Date	7/27/2020

Channel	Frequency (MHz)	Average Power ANT 4 (dBm)	Average Power ANT 3 (dBm)	Total Average Power (dBm)
Low	2402	17.36	17.28	20.33
Middle	2441	17.44	17.38	20.42
High	2480	17.39	17.26	20.34

### 9.7.8. HIGH POWER ENHANCED RATE TXBF QPSK MODULATION

#### 2TX ANT 4 + ANT 3 TxBF Mode

Tested By:	20773
Date	7/27/2020

Channel	Frequency (MHz)	Average Power ANT 4 (dBm)	Average Power ANT 3 (dBm)	Total Average Power (dBm)
Low	2402	14.41	14.45	17.44
Middle	2441	14.44	14.51	17.49
High	2480	14.43	14.46	17.46

### 9.7.9. HIGH POWER ENHANCED DATA RATE TXBF 8PSK MODULATION

#### 2TX ANT 4 + ANT 3 TxBF Mode

Tested By:	20773
Date	7/27/2020

Channel	Frequency (MHz)	Average Power ANT 4 (dBm)	Average Power ANT 3 (dBm)	Total Average Power (dBm)
Low	2402	14.60	14.69	17.66
Middle	2441	14.63	14.72	17.69
High	2480	14.66	14.66	17.67

### 9.7.10. LOW POWER BASIC DATA RATE TXBF GFSK MODULATION

**2TX ANT 4 + ANT 3 TxBF Mode**

Tested By:	20773
Date	7/27/2020

Channel	Frequency (MHz)	Average Power ANT 4 (dBm)	Average Power ANT 3 (dBm)	Total Average Power (dBm)
Low	2402	12.24	12.30	15.28
Middle	2441	12.30	12.44	15.38
High	2480	12.29	12.28	15.30

### 9.7.11. LOW POWER ENHANCED DATA RATE TXBF QPSK MODULATION

**2TX ANT 4 + ANT 3 TxBF Mode**

Tested By:	20773
Date	7/27/2020

Channel	Frequency (MHz)	Average Power ANT 4 (dBm)	Average Power ANT 3 (dBm)	Total Average Power (dBm)
Low	2402	8.49	8.41	11.46
Middle	2441	8.41	8.52	11.48
High	2480	8.46	8.42	11.45

### 9.7.12. LOW POWER ENHANCED DATA RATE TXBF 8PSK MODULATION

**2TX ANT 4 + ANT 3 TxBF Mode**

Tested By:	20773
Date	7/27/2020

Channel	Frequency (MHz)	Average Power ANT 4 (dBm)	Average Power ANT 3 (dBm)	Total Average Power (dBm)
Low	2402	8.69	8.72	11.72
Middle	2441	8.78	8.79	11.80
High	2480	8.77	8.71	11.75

## **9.8. CONDUCTED SPURIOUS EMISSIONS**

### **LIMITS**

FCC §15.247 (d)

RSS-247 5.5

Limit = -20 dBc

### **TEST PROCEDURE**

The transmitter output is connected to a spectrum analyzer. The resolution bandwidth is set to 100 kHz. The video bandwidth is set to 300 kHz.

The spectrum from 30 MHz to 26 GHz is investigated with the transmitter set to the lowest, middle, and highest channels.

The bandedges at 2.4 and 2.4835 GHz are investigated with the transmitter set to the normal hopping mode.

### **RESULTS**

## 9.8.1. HIGH POWER BASIC DATA RATE GFSK MODULATION

### ANT 4 SPURIOUS EMISSIONS, NON-HOPPING

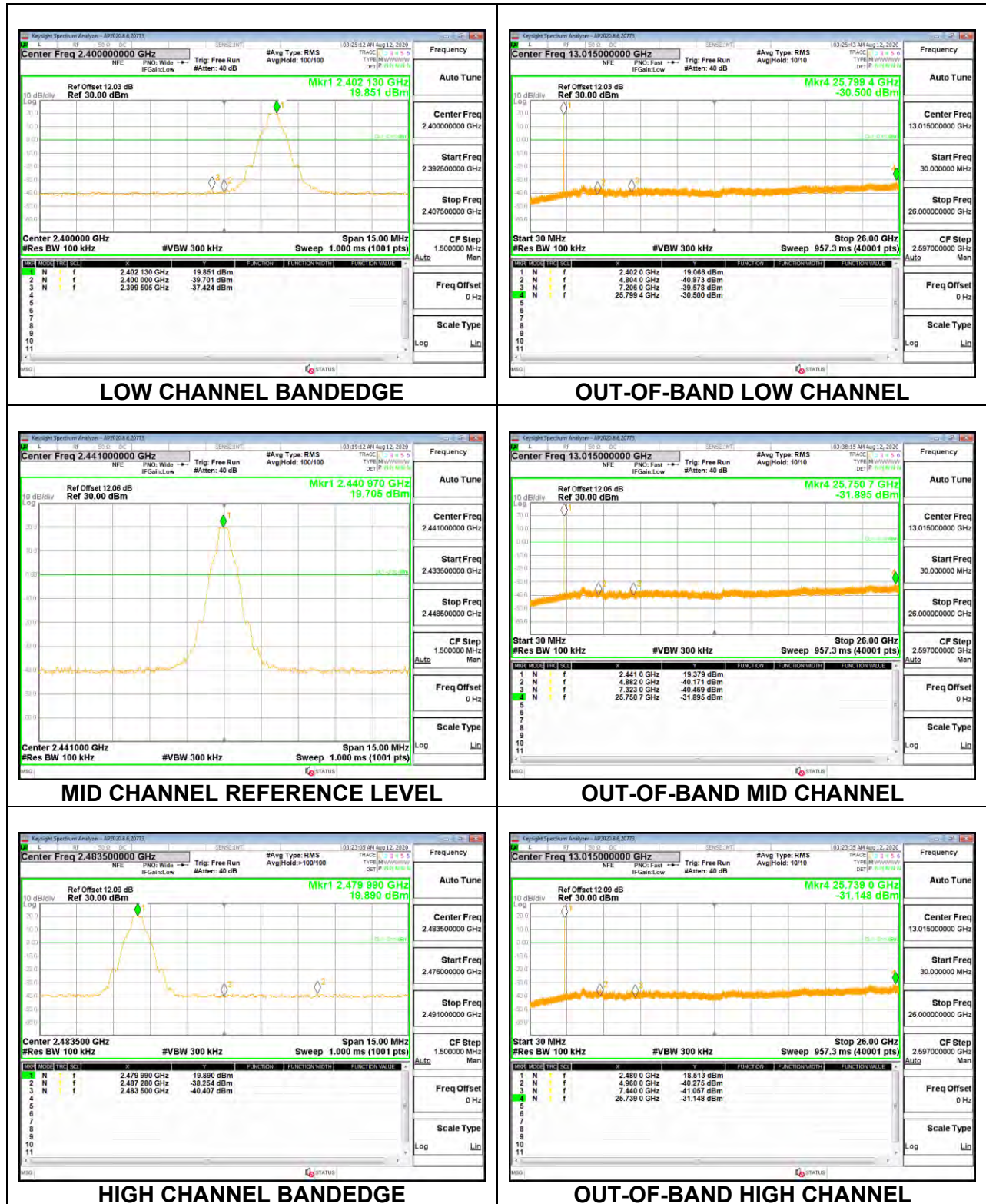

**ANT 4 SPURIOUS BANDEDGE EMISSIONS WITH HOPPING ON**

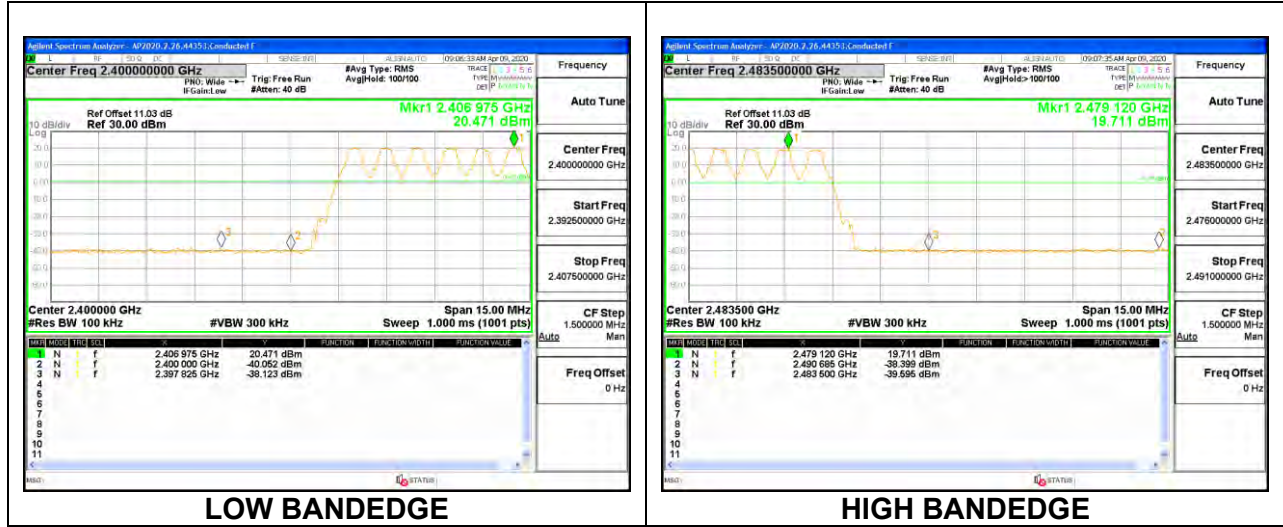



**ANT 3 SPURIOUS EMISSIONS, NON-HOPPING**

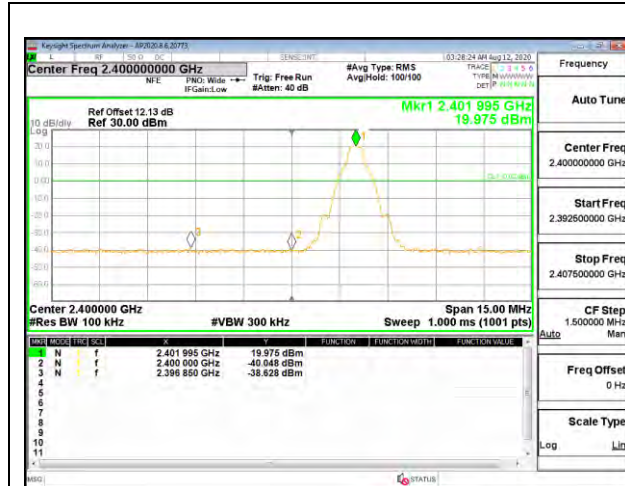

**LOW CHANNEL BANDEDGE**

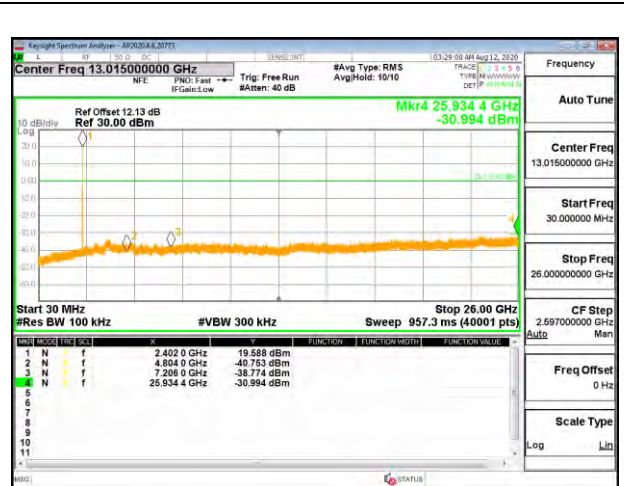

**OUT-OF-BAND LOW CHANNEL**

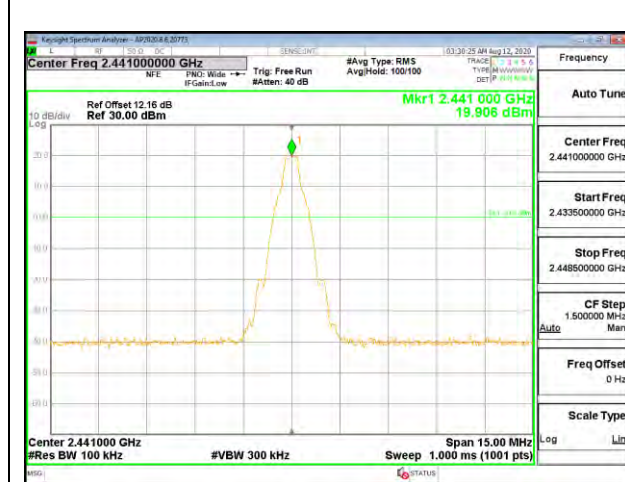

**MID CHANNEL REFERENCE LEVEL**



**OUT-OF-BAND MID CHANNEL**

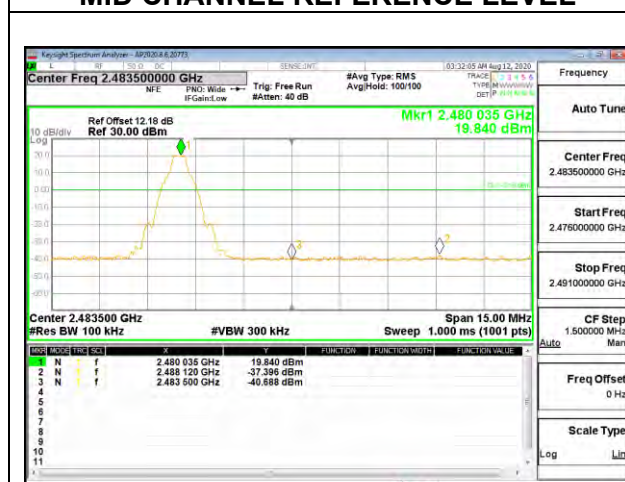

**HIGH CHANNEL BANDEDGE**

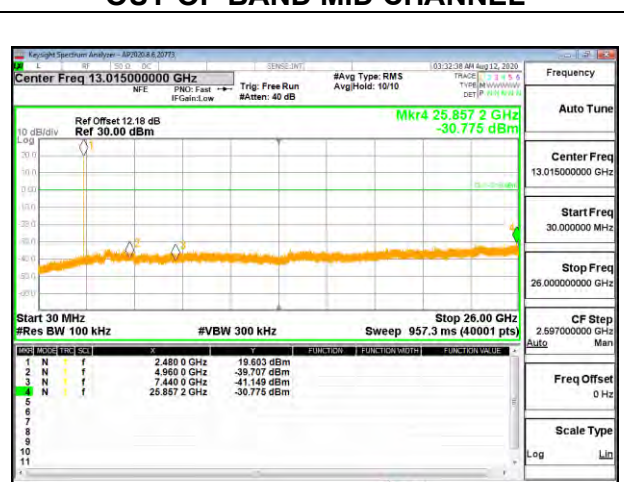

**OUT-OF-BAND HIGH CHANNEL**

**ANT 3 SPURIOUS BANDEDGE EMISSIONS WITH HOPPING ON**

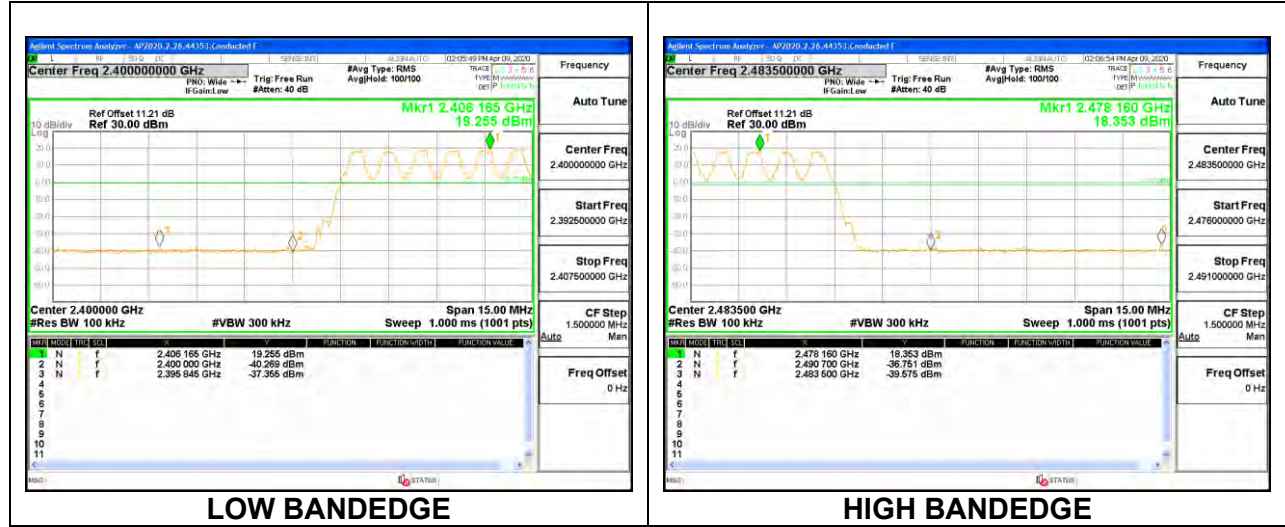

## 9.8.2. HIGH POWER ENHANCED DATA RATE 8PSK MODULATION

### ANT 4 SPURIOUS EMISSIONS, NON-HOPPING



LOW CHANNEL BANDEDGE

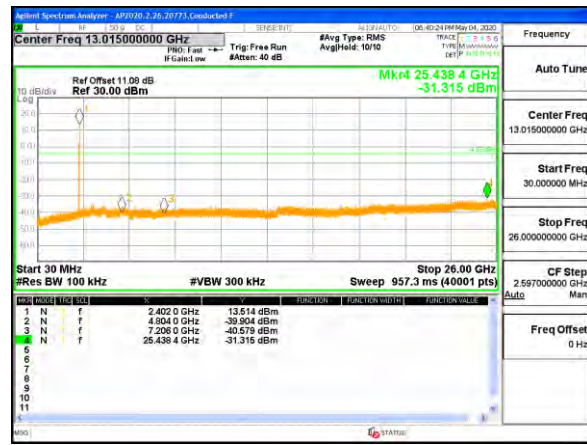

OUT-OF-BAND LOW CHANNEL

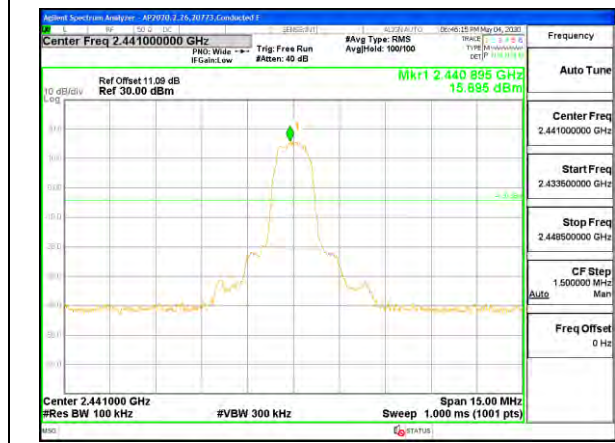

MID CHANNEL REFERENCE LEVEL



OUT-OF-BAND MID CHANNEL



HIGH CHANNEL BANDEDGE

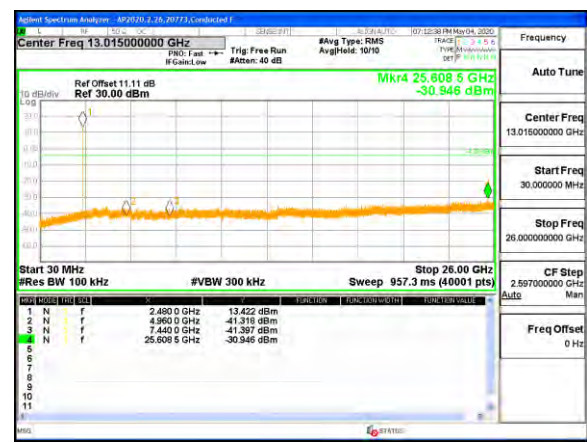

OUT-OF-BAND HIGH CHANNEL

**ANT 4 SPURIOUS BANDEDGE EMISSIONS WITH HOPPING ON**

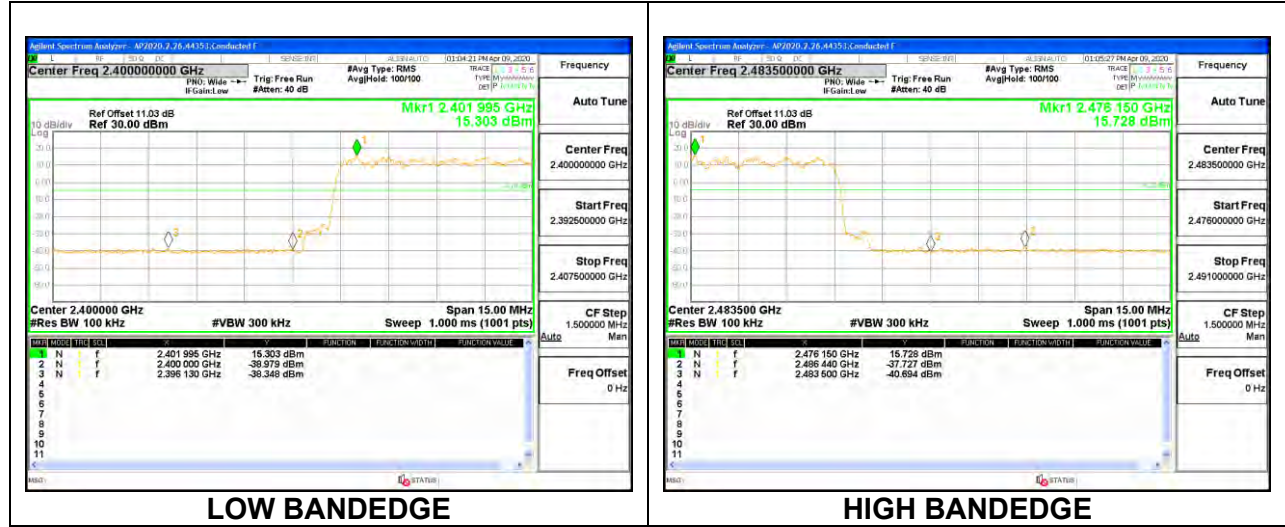

**ANT 3 SPURIOUS EMISSIONS, NON-HOPPING**

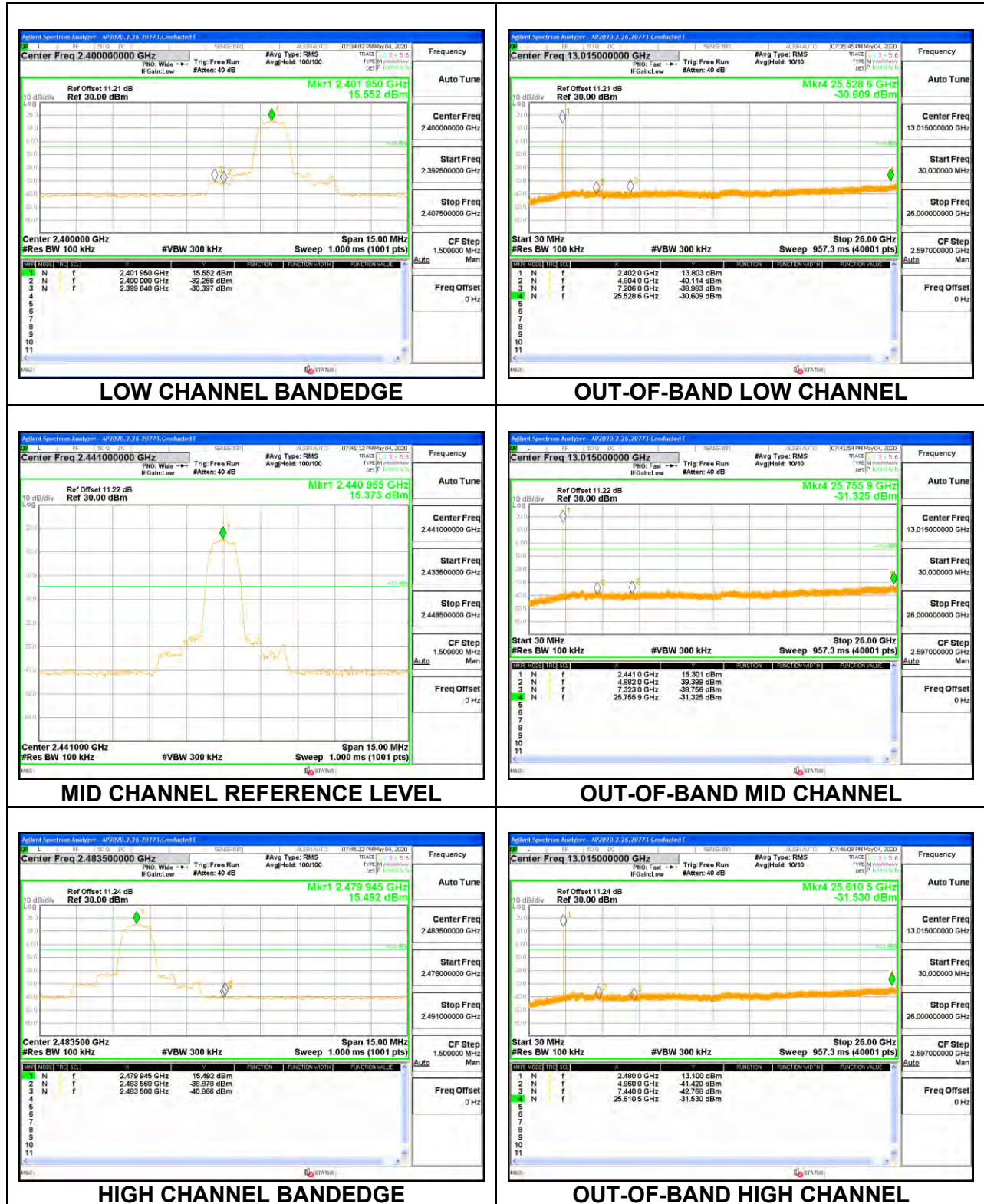

**ANT 3 SPURIOUS BANDEDGE EMISSIONS WITH HOPPING ON**

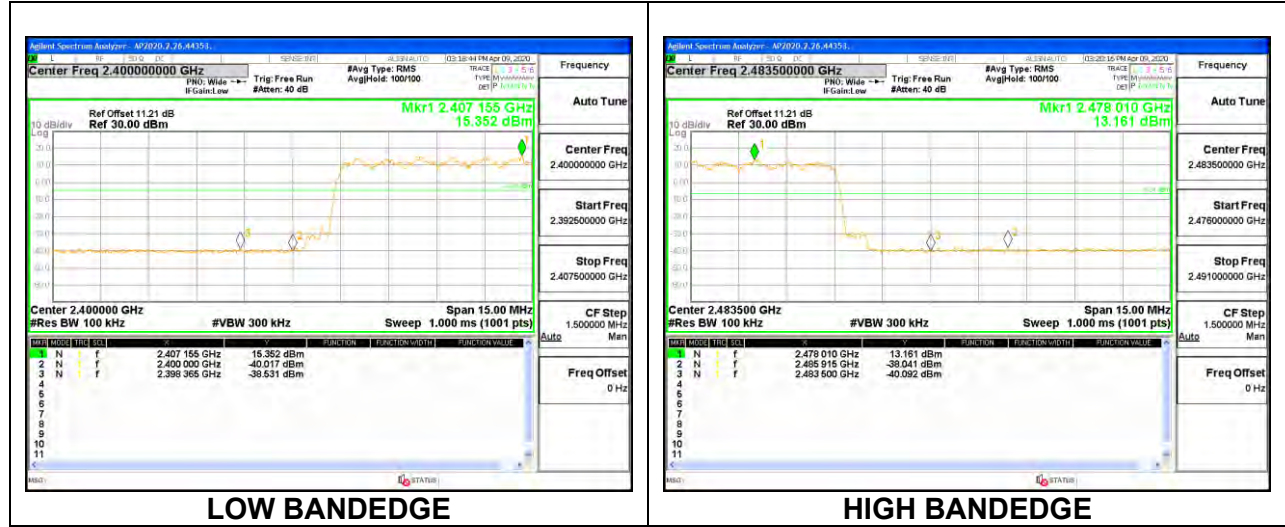

### 9.8.3. LOW POWER BASIC DATA RATE GFSK MODULATION

#### ANT 4 SPURIOUS EMISSIONS, NON-HOPPING



**LOW CHANNEL BANDEDGE**



**OUT-OF-BAND LOW CHANNEL**

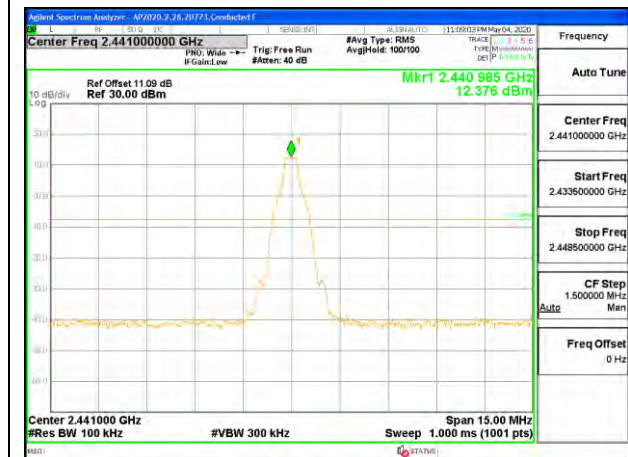

**MID CHANNEL REFERENCE LEVEL**



**OUT-OF-BAND MID CHANNEL**



**HIGH CHANNEL BANDEDGE**



**OUT-OF-BAND HIGH CHANNEL**

**ANT 4 SPURIOUS BANDEDGE EMISSIONS WITH HOPPING ON**





**ANT 3 SPURIOUS EMISSIONS, NON-HOPPING**



**LOW CHANNEL BANDEDGE**



**OUT-OF-BAND LOW CHANNEL**

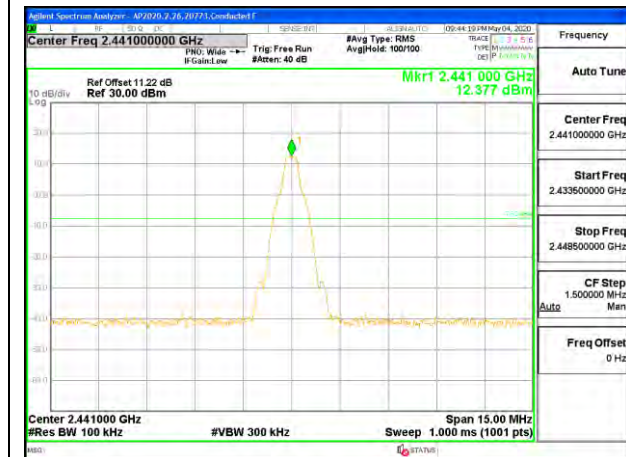

**MID CHANNEL REFERENCE LEVEL**

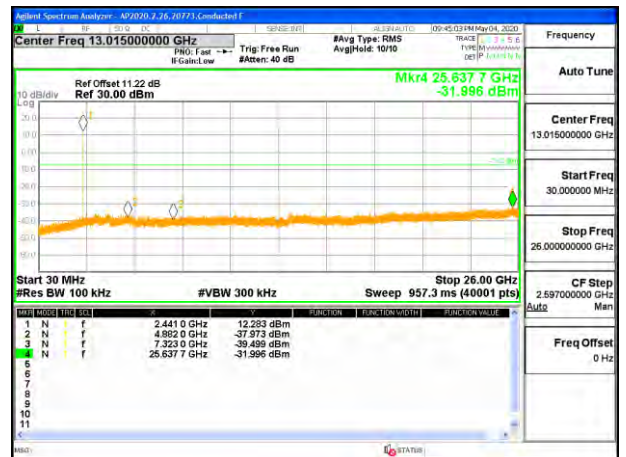

**OUT-OF-BAND MID CHANNEL**

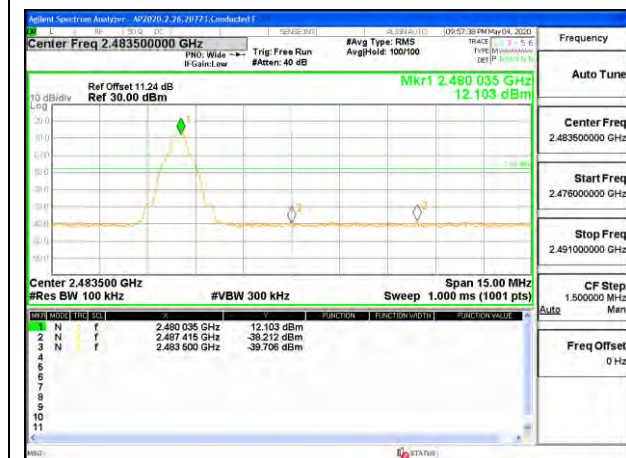

**HIGH CHANNEL BANDEDGE**

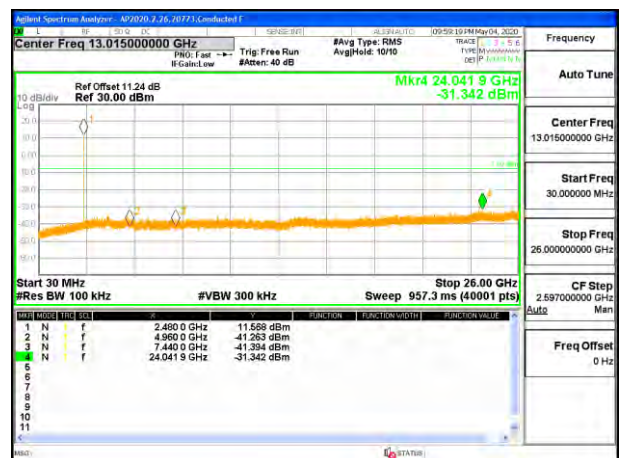

**OUT-OF-BAND HIGH CHANNEL**

**ANT 3 SPURIOUS BANDEDGE EMISSIONS WITH HOPPING ON**

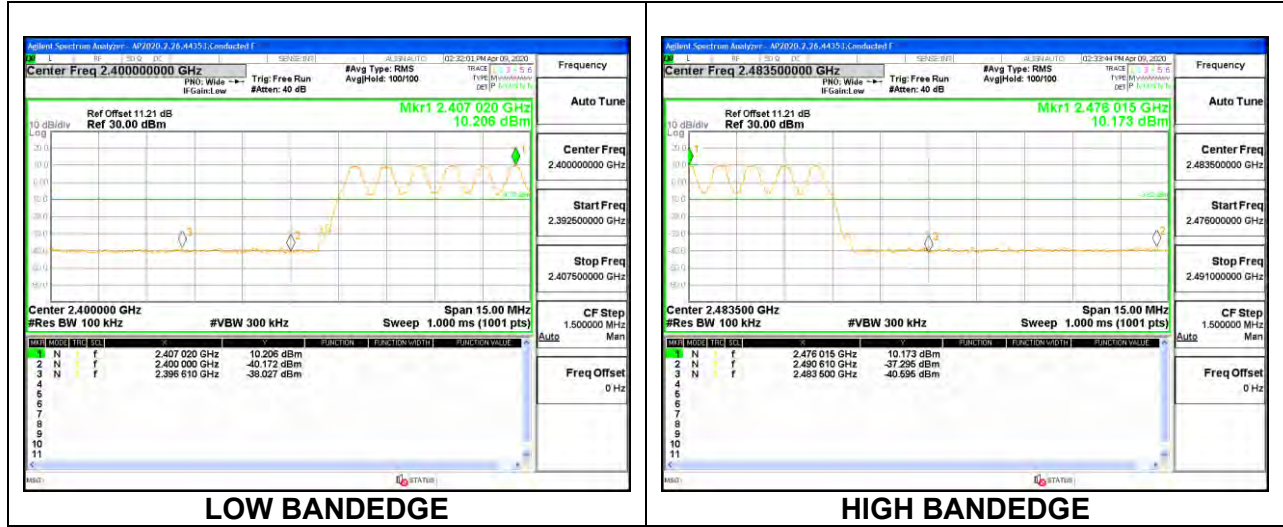

### 9.8.4. LOW POWER ENHANCED DATA RATE 8PSK MODULATION

#### ANT 4 SPURIOUS EMISSIONS, NON-HOPPING



**LOW CHANNEL BANDEDGE**

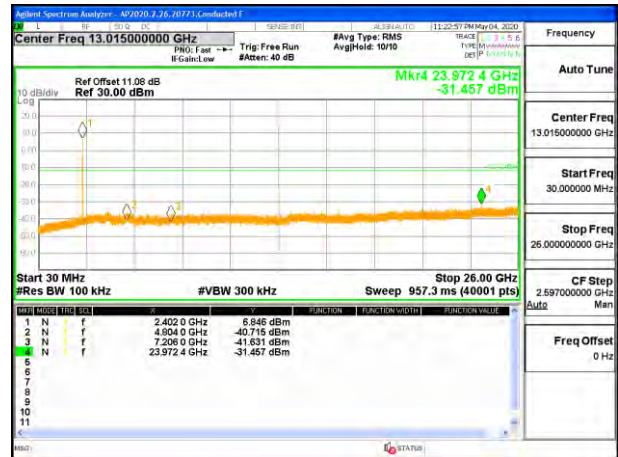

**OUT-OF-BAND LOW CHANNEL**

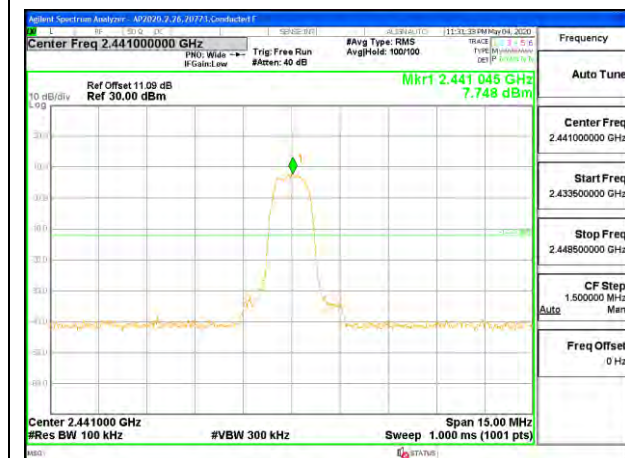

**MID CHANNEL REFERENCE LEVEL**



**OUT-OF-BAND MID CHANNEL**

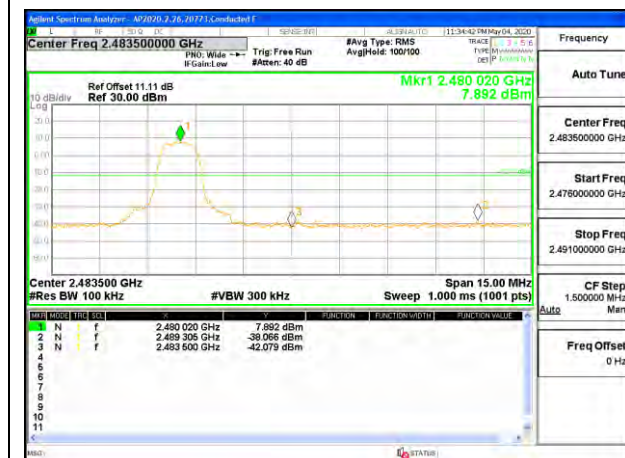

**HIGH CHANNEL BANDEDGE**



**OUT-OF-BAND HIGH CHANNEL**

**LAT 4 SPURIOUS BANDEDGE EMISSIONS WITH HOPPING ON**

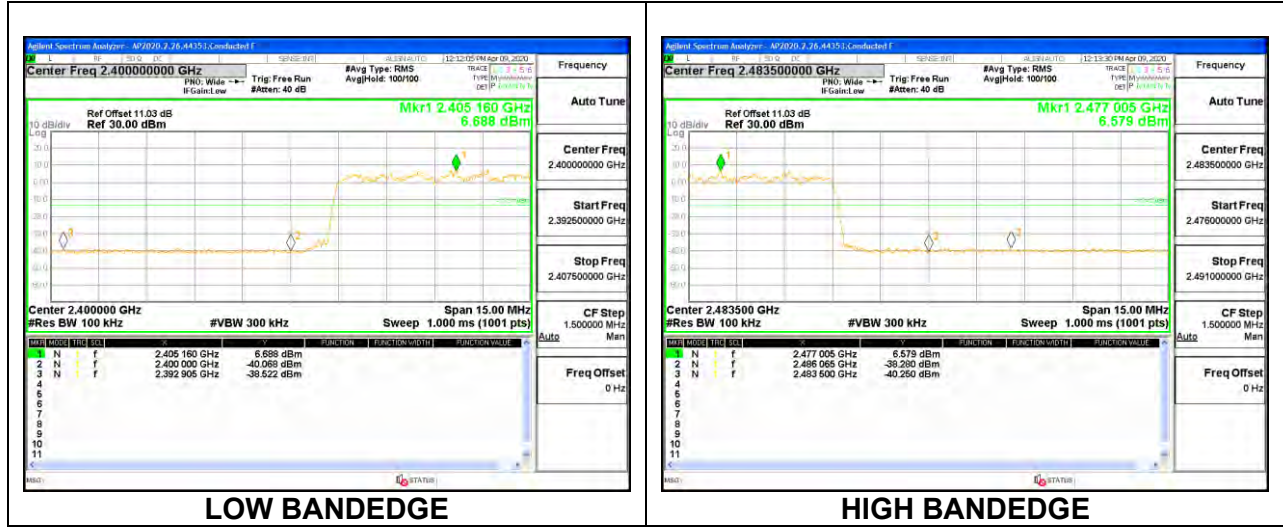

**ANT 3 SPURIOUS EMISSIONS, NON-HOPPING**

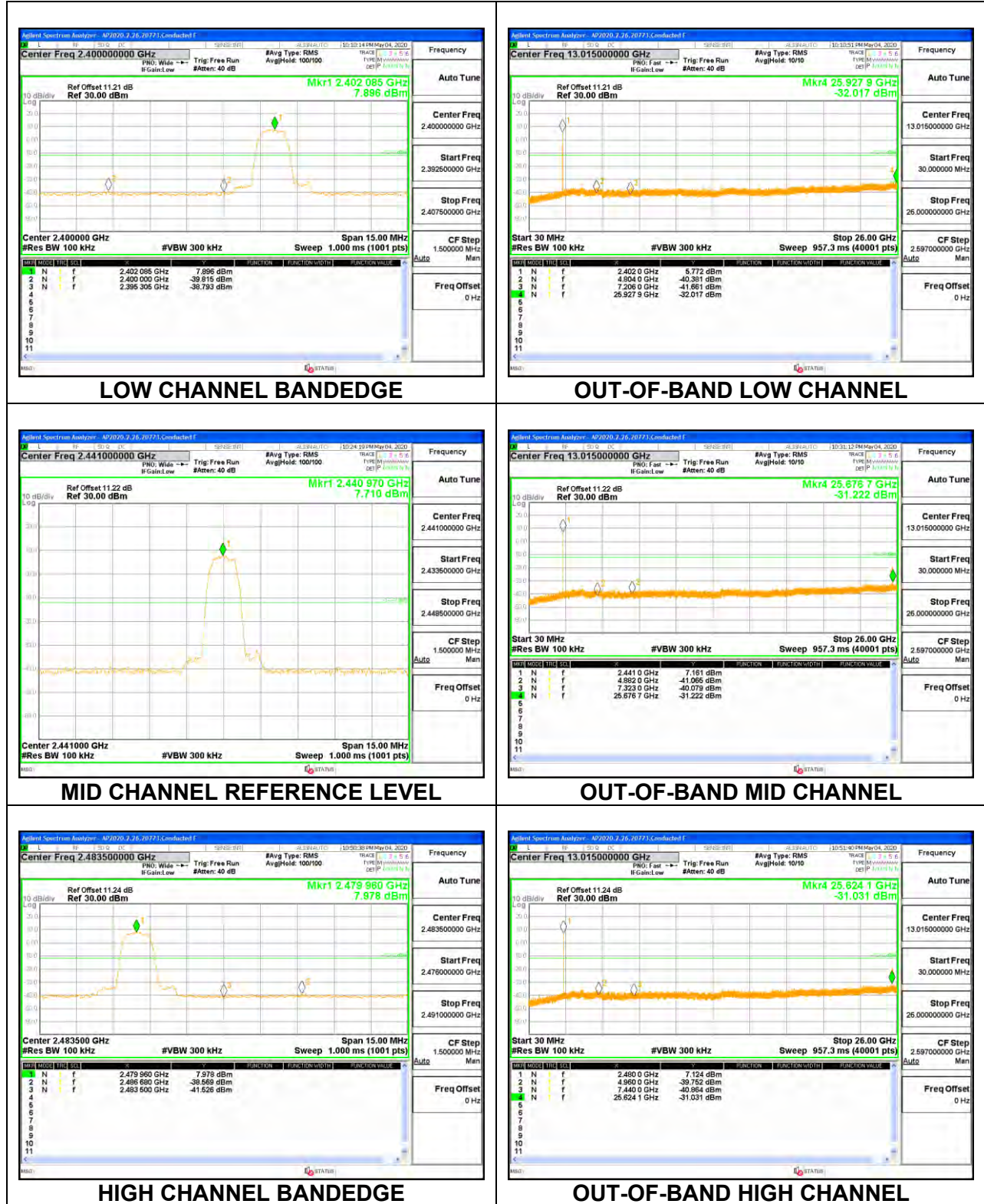

**ANT 3 SPURIOUS BANDEDGE EMISSIONS WITH HOPPING ON**

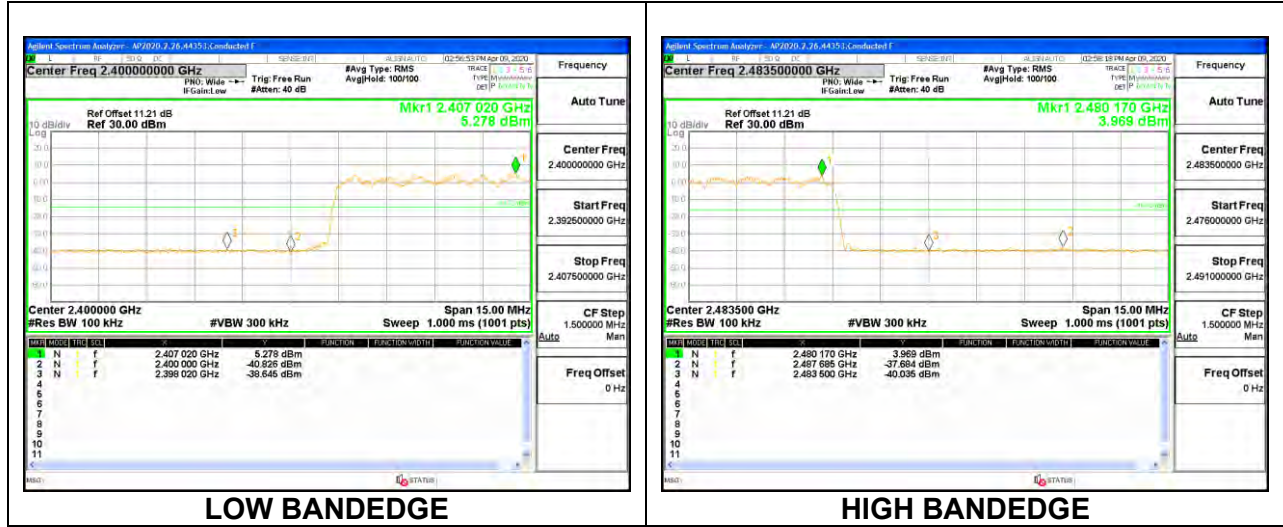

## 9.8.5. HIGH POWER BASIC DATA RATE TXBF GFSK MODULATION

### ANT 4 SPURIOUS EMISSIONS, NON-HOPPING

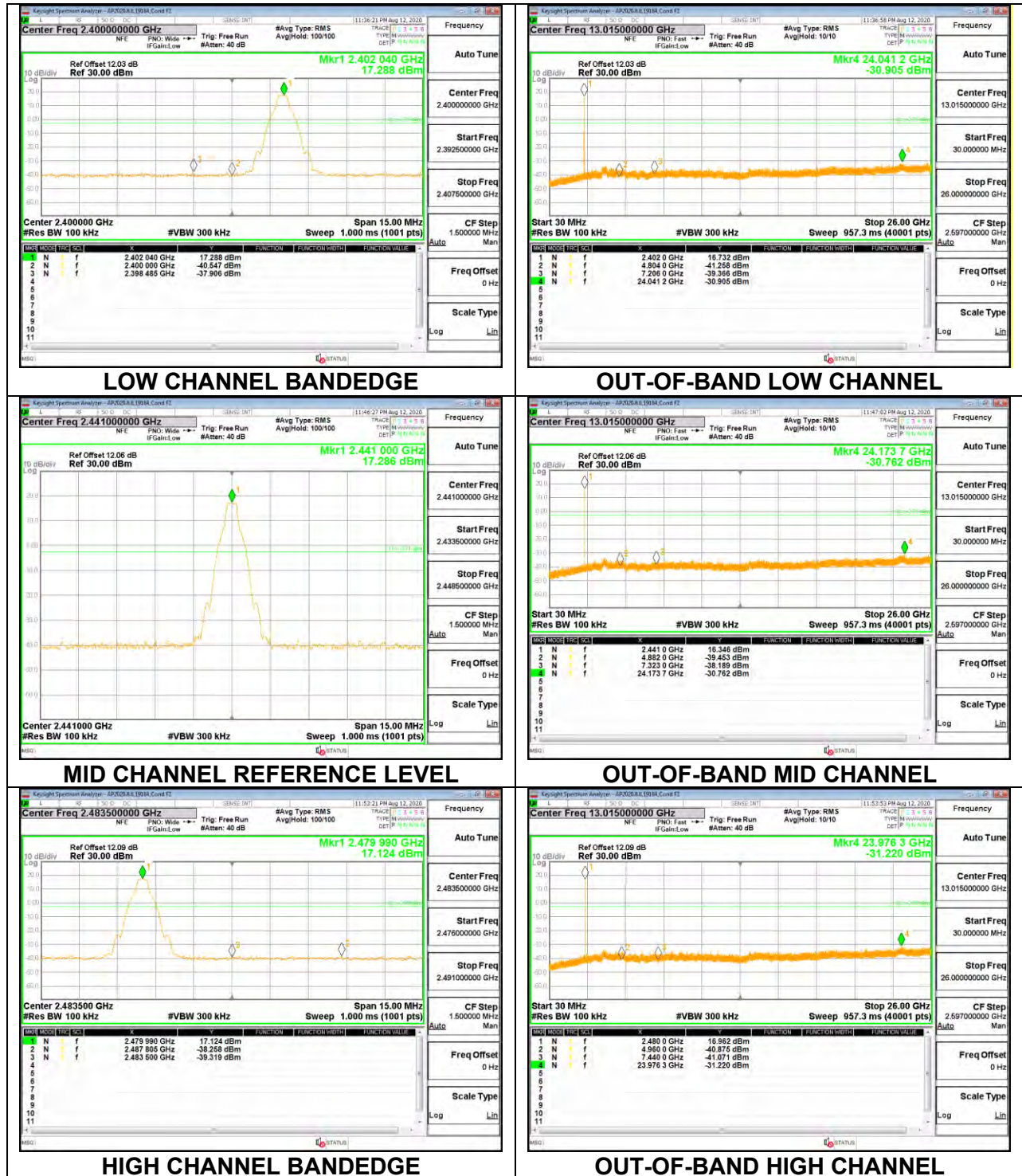

**ANT 4 SPURIOUS BANDEDGE EMISSIONS WITH HOPPING ON**

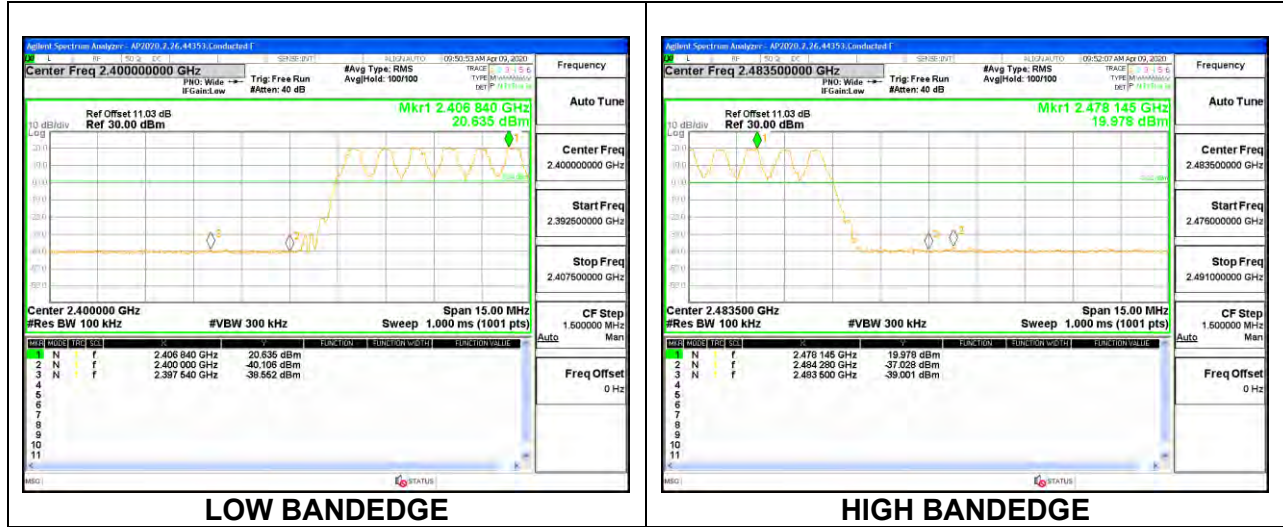



**ANT 3 SPURIOUS EMISSIONS, NON-HOPPING**



**ANT 3 SPURIOUS BANDEDGE EMISSIONS WITH HOPPING ON**

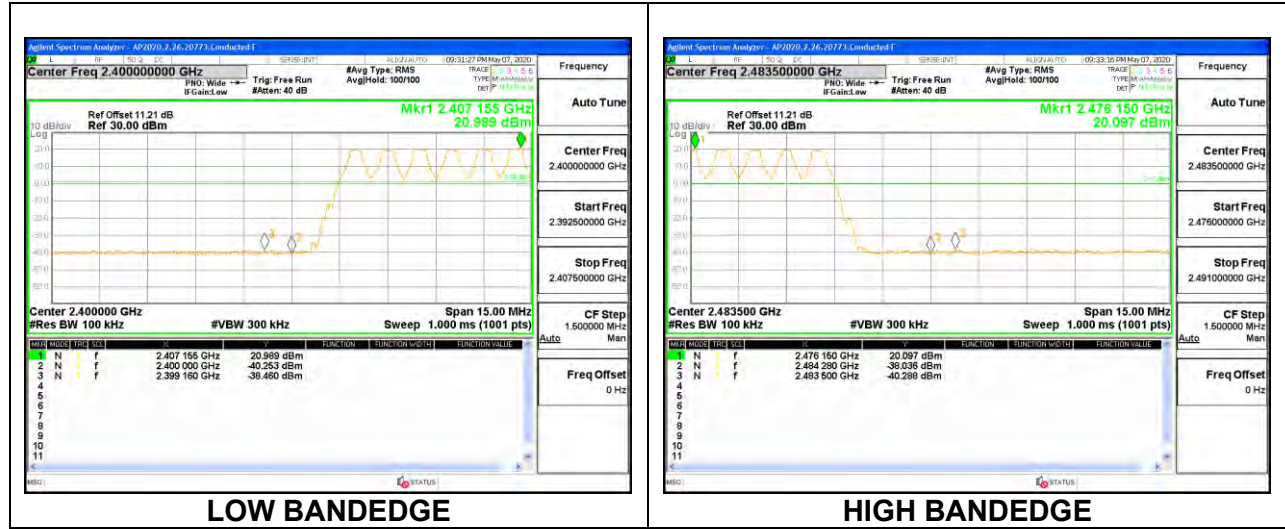

## 9.8.6. HIGH POWER ENHANCED DATA RATE TXBF 8PSK MODULATION

### ANT 4 SPURIOUS EMISSIONS, NON-HOPPING

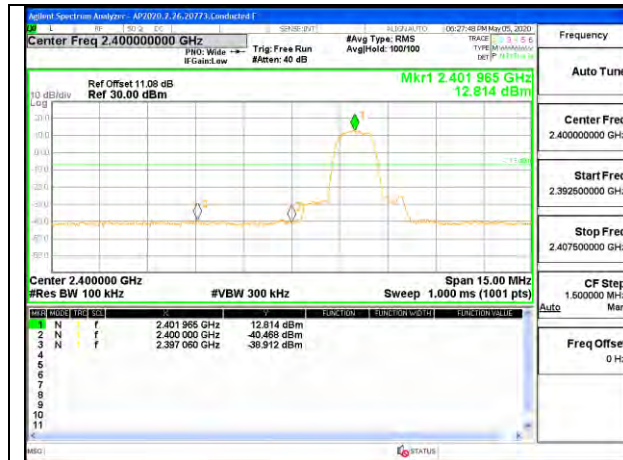

**LOW CHANNEL BANDEDGE**

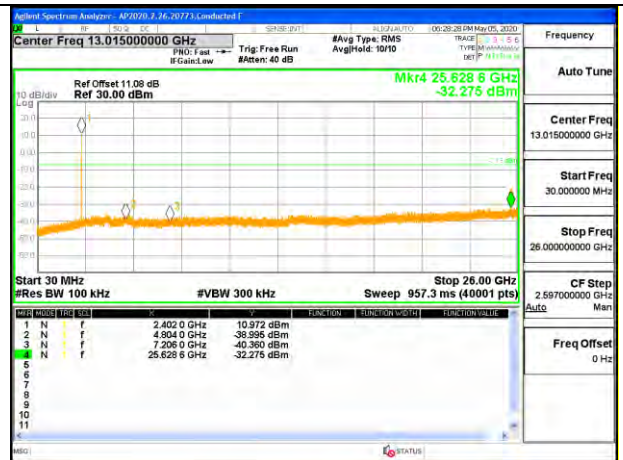

**OUT-OF-BAND LOW CHANNEL**

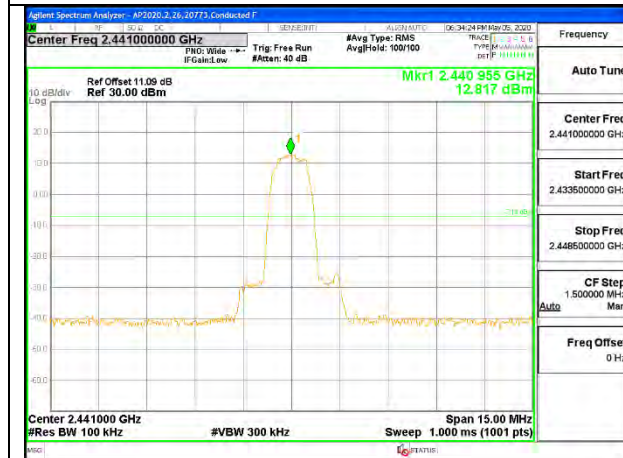

**MID CHANNEL REFERENCE LEVEL**

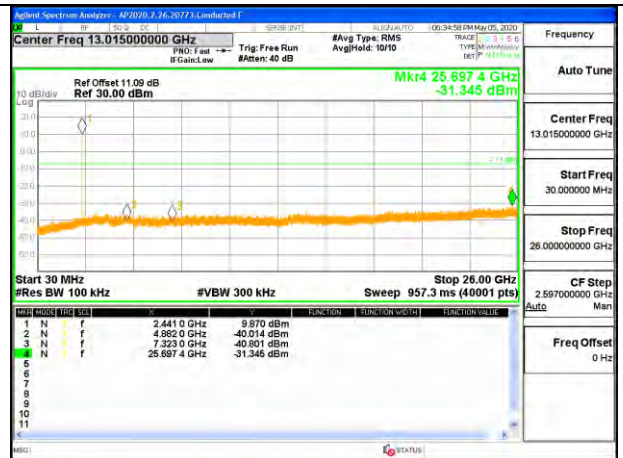

**OUT-OF-BAND MID CHANNEL**



**HIGH CHANNEL BANDEDGE**



**OUT-OF-BAND HIGH CHANNEL**

**ANT 4 SPURIOUS BANDEDGE EMISSIONS WITH HOPPING ON**



**ANT 3 SPURIOUS EMISSIONS, NON-HOPPING**



**LOW CHANNEL BANDEDGE**

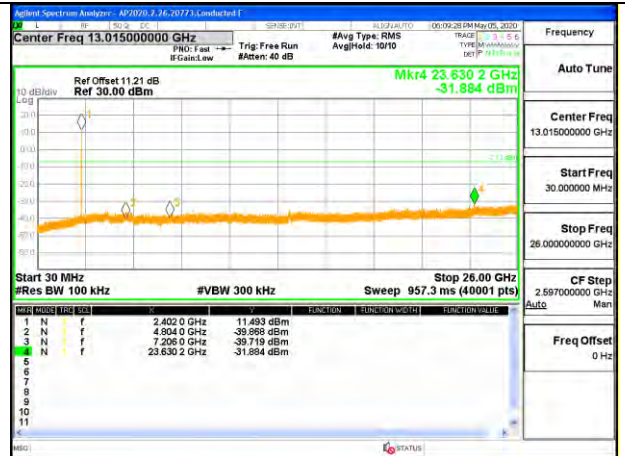

**OUT-OF-BAND LOW CHANNEL**

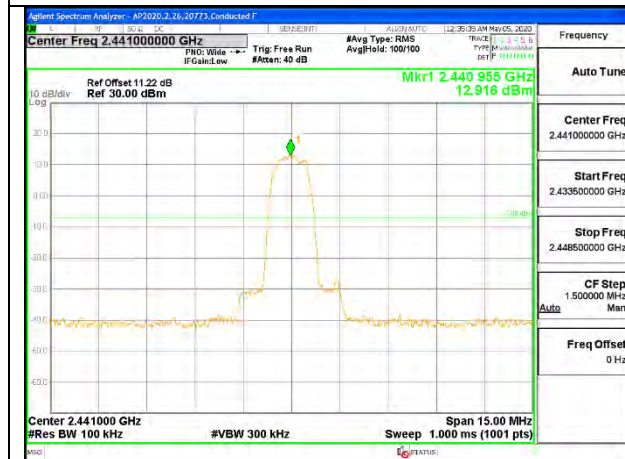

**MID CHANNEL REFERENCE LEVEL**



**OUT-OF-BAND MID CHANNEL**

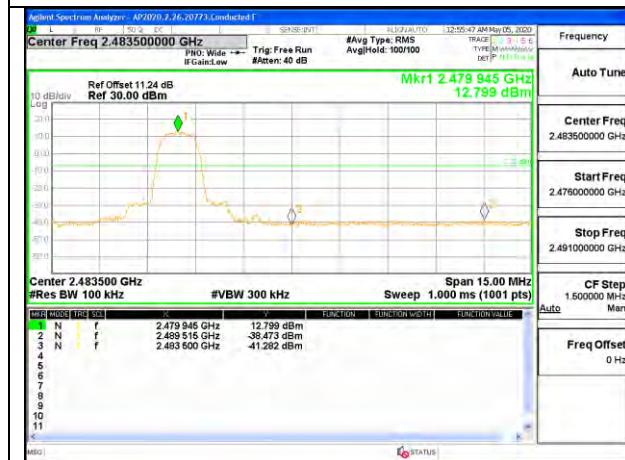

**HIGH CHANNEL BANDEDGE**



**OUT-OF-BAND HIGH CHANNEL**

**ANT 3 SPURIOUS BANDEDGE EMISSIONS WITH HOPPING ON**

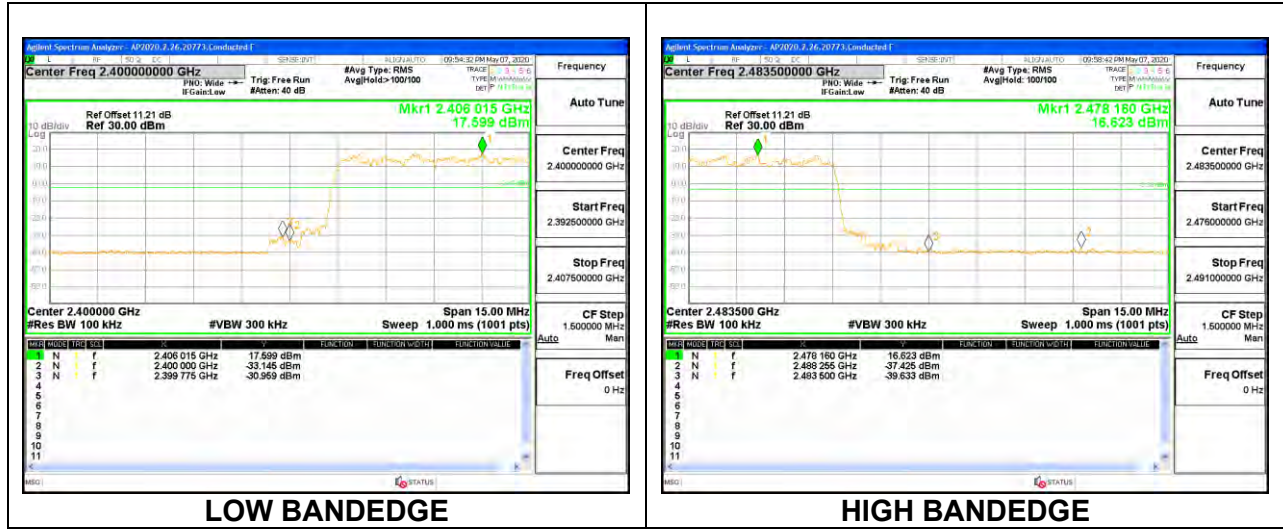

### 9.8.7. LOW POWER BASIC DATA RATE TXBF GFSK MODULATION

#### ANT 4 SPURIOUS EMISSIONS, NON-HOPPING



**LOW CHANNEL BANDEDGE**



**OUT-OF-BAND LOW CHANNEL**

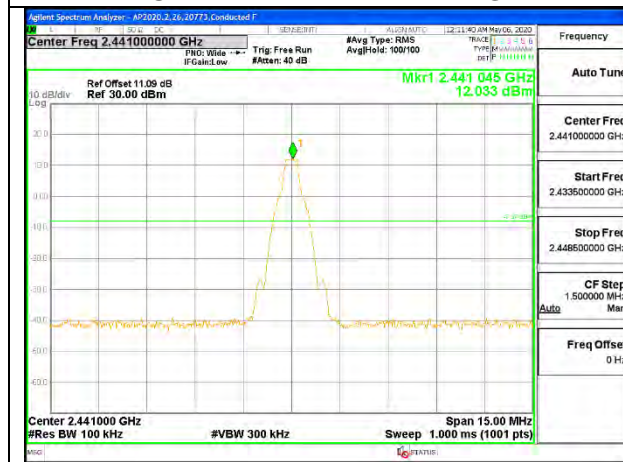

**MID CHANNEL REFERENCE LEVEL**

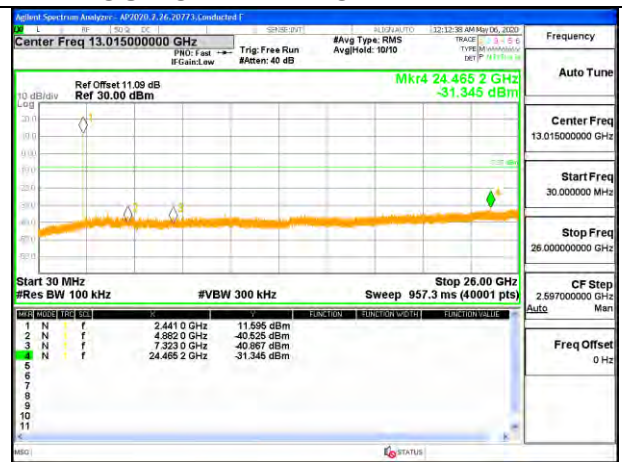

**OUT-OF-BAND MID CHANNEL**



**HIGH CHANNEL BANDEDGE**

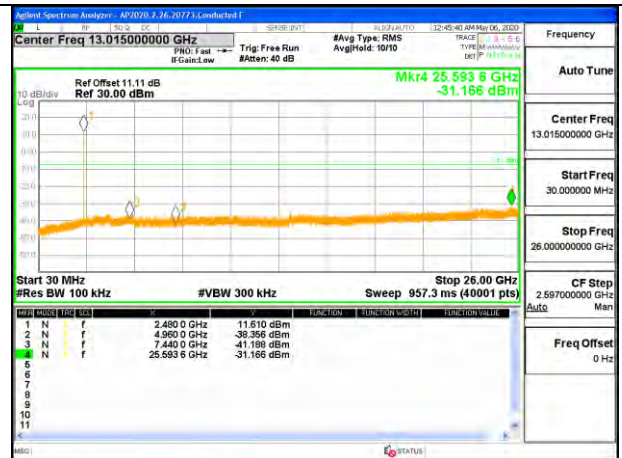

**OUT-OF-BAND HIGH CHANNEL**

**ANT 4 SPURIOUS BANDEDGE EMISSIONS WITH HOPPING ON**

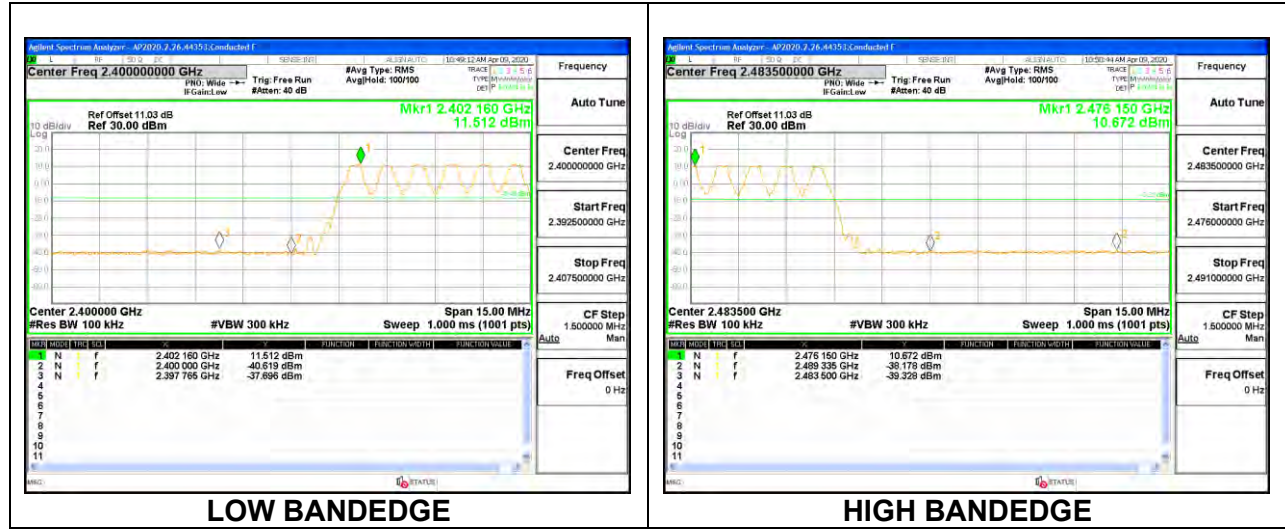



**ANT 3 SPURIOUS EMISSIONS, NON-HOPPING**

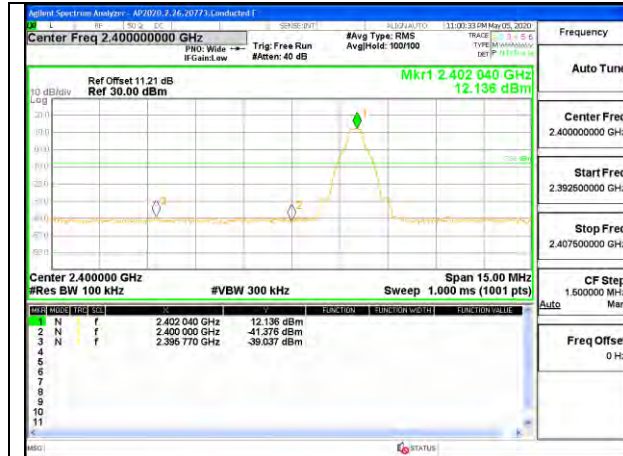

**LOW CHANNEL BANDEDGE**

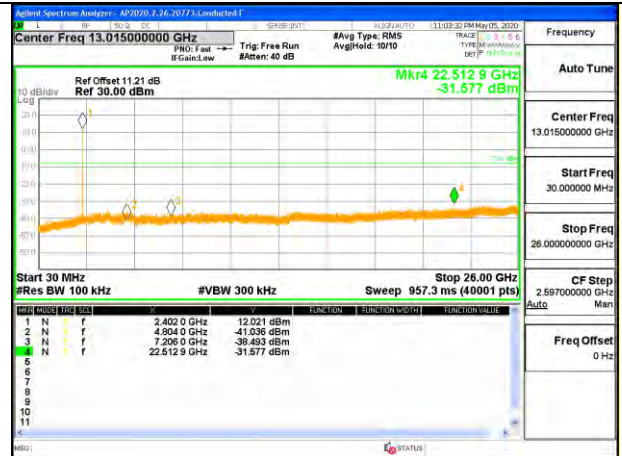

**OUT-OF-BAND LOW CHANNEL**

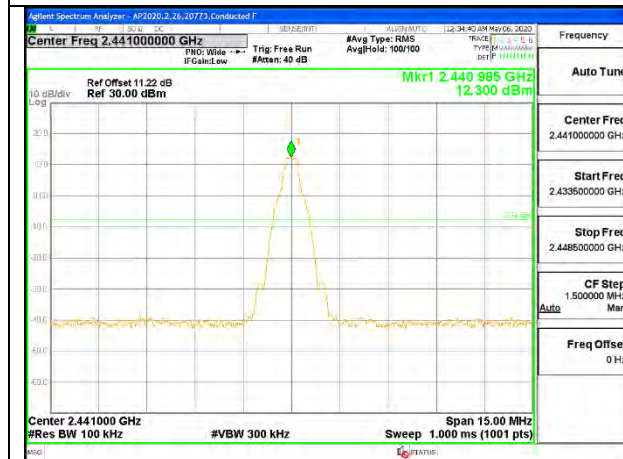

**MID CHANNEL REFERENCE LEVEL**



**OUT-OF-BAND MID CHANNEL**



**HIGH CHANNEL BANDEDGE**



**OUT-OF-BAND HIGH CHANNEL**

**ANT 3 SPURIOUS BANDEDGE EMISSIONS WITH HOPPING ON**

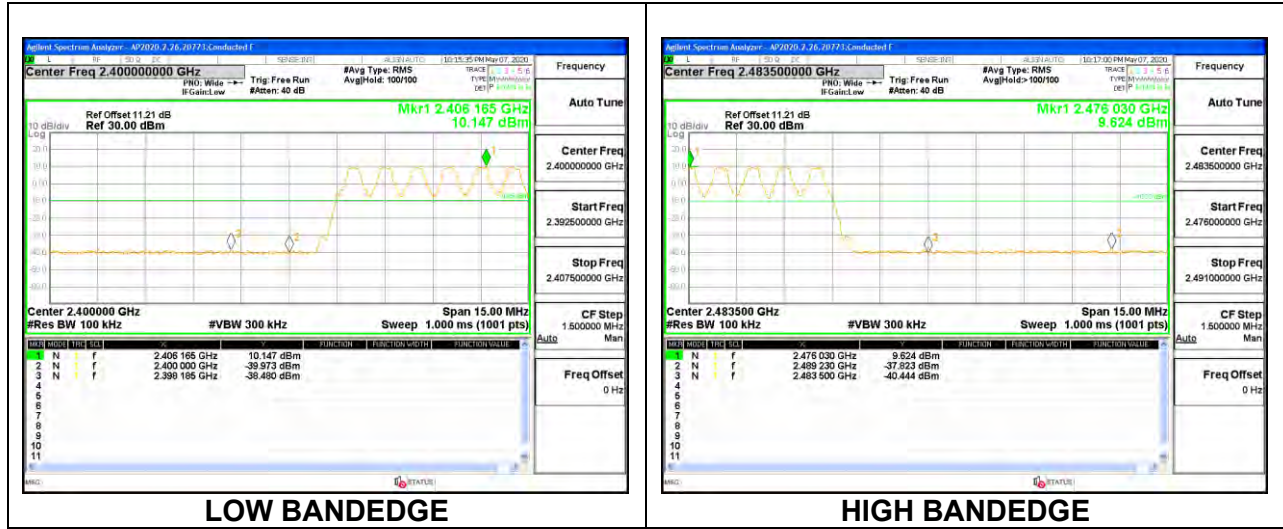

## 9.8.8. LOW POWER ENHANCED DATA RATE TXBF 8PSK MODULATION

### ANT 4 SPURIOUS EMISSIONS, NON-HOPPING



**LOW CHANNEL BANDEDGE**

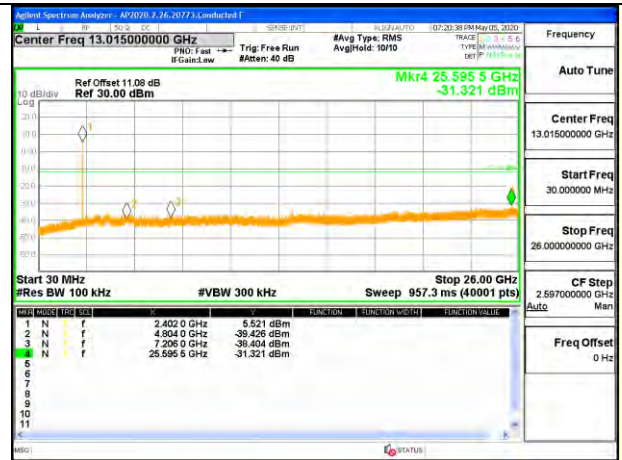

**OUT-OF-BAND LOW CHANNEL**

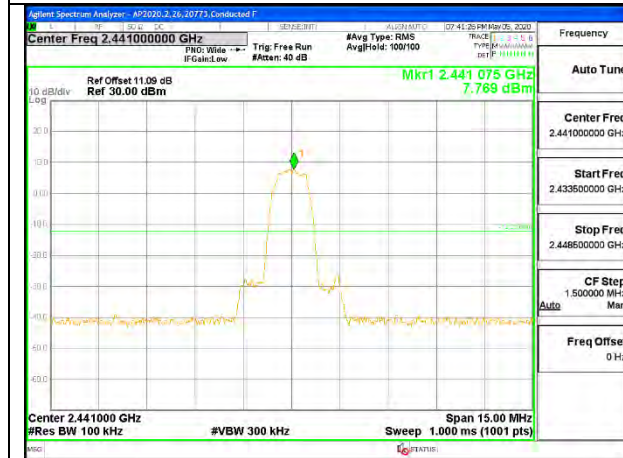

**MID CHANNEL REFERENCE LEVEL**

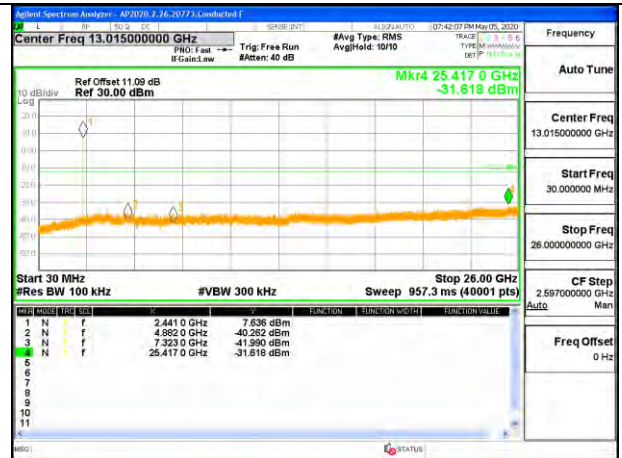

**OUT-OF-BAND MID CHANNEL**



**HIGH CHANNEL BANDEDGE**

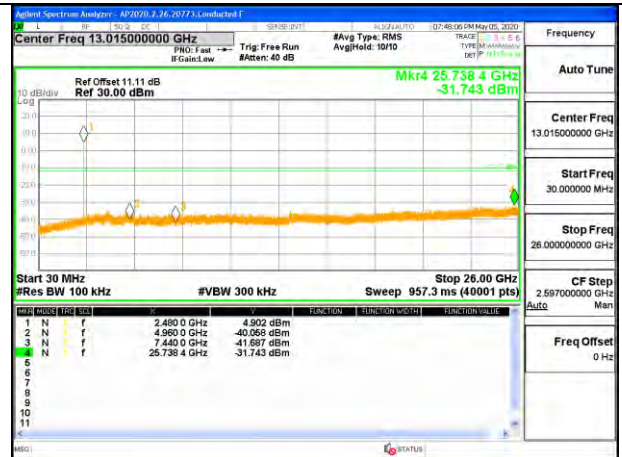

**OUT-OF-BAND HIGH CHANNEL**

**ANT 4 SPURIOUS BANDEDGE EMISSIONS WITH HOPPING ON**

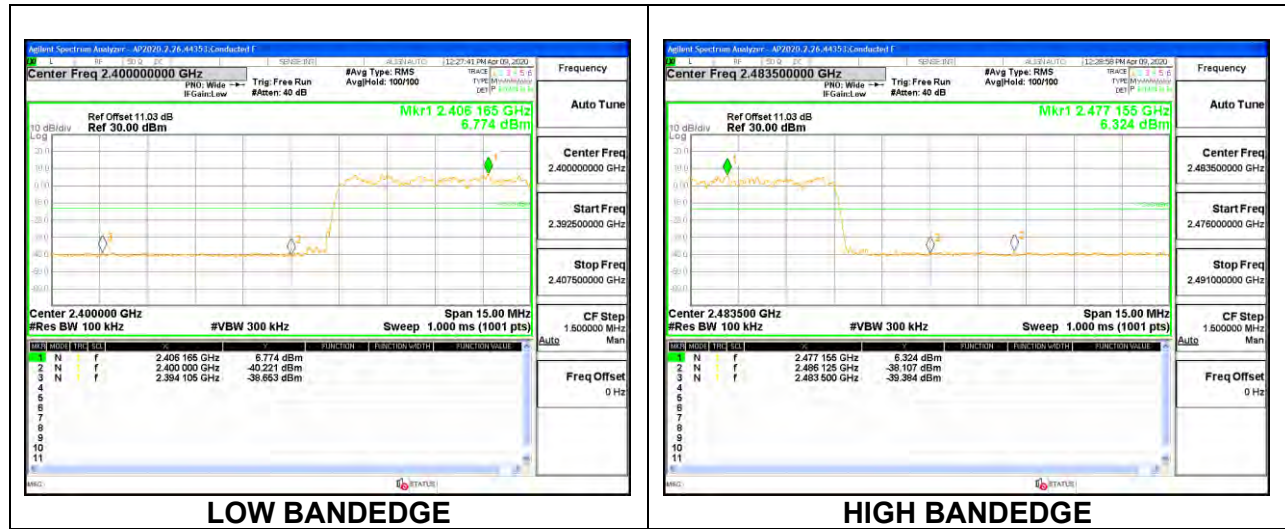

**ANT 3 SPURIOUS EMISSIONS, NON-HOPPING**



**LOW CHANNEL BANDEDGE**

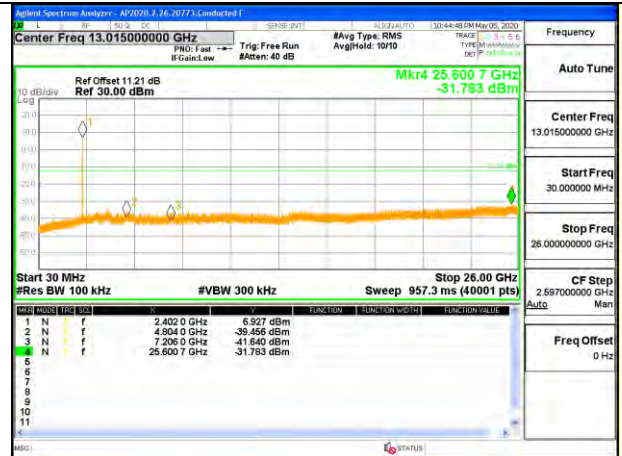

**OUT-OF-BAND LOW CHANNEL**

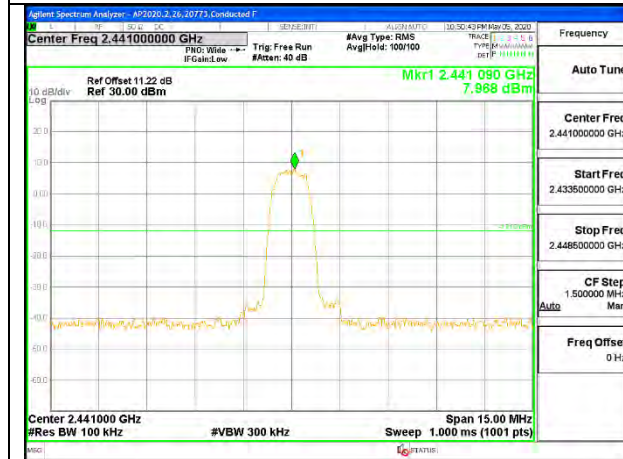

**MID CHANNEL REFERENCE LEVEL**

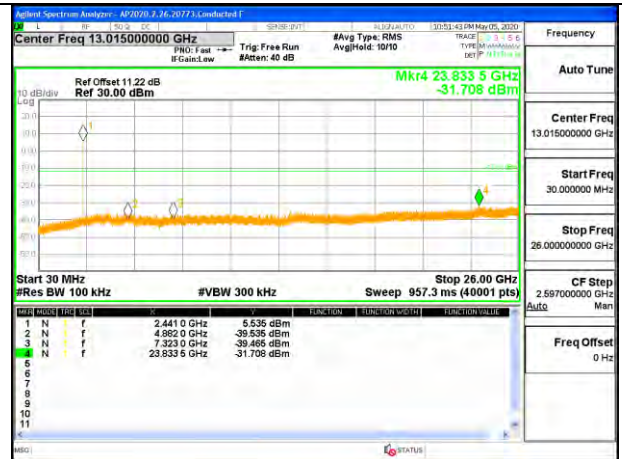

**OUT-OF-BAND MID CHANNEL**



**HIGH CHANNEL BANDEDGE**

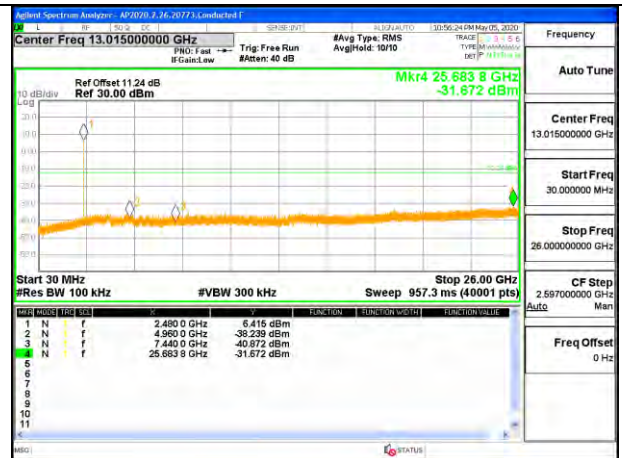

**OUT-OF-BAND HIGH CHANNEL**

**ANT 3 SPURIOUS BANDEDGE EMISSIONS WITH HOPPING ON**

