



TEST REPORT

Report Number: 13179116-E4V2

Applicant : APPLE, INC.
1 APPLE PARK WAY
CUPERTINO, CA 95014, U.S.A

Model : A2172

FCC ID : BCG-E3542A

IC : 579C-E3542A

EUT Description : Smartphone

Test Standard(s) : FCC 47 CFR PART 15 SUBPART C
ISED RSS-247 ISSUE 2
ISED RSS-GEN ISSUE 5

Date Of Issue:

September 08, 2020

Prepared by:

UL Verification Services Inc.
47173 Benicia Street
Fremont, CA 94538 U.S.A.
TEL: (510) 319-4000
FAX: (510) 661-0888



NVLAP Lab code: 200065-0

REPORT REVISION HISTORY

Rev.	Issue Date	Revisions	Revised By
V1	8/26/2020	Initial Issue	Chin Pang
V2	9/8/2020	Address TCB's Questions	Chin Pang

REPORT REVISION HISTORY 2

1. ATTESTATION OF TEST RESULTS 5

2. TEST RESULTS SUMMARY 6

3. TEST METHODOLOGY 6

4. FACILITIES AND ACCREDITATION 6

5. DECISION RULES AND MEASUREMENT UNCERTAINTY 7

 5.1. *METROLOGICAL TRACEABILITY* 7

 5.2. *DECISION RULES*..... 7

 5.3. *MEASUREMENT UNCERTAINTY*..... 7

6. EQUIPMENT UNDER TEST 8

 6.1. *EUT DESCRIPTION* 8

 6.2. *MAXIMUM OUTPUT POWER*..... 8

 6.3. *DESCRIPTION OF AVAILABLE ANTENNAS* 8

 6.4. *SOFTWARE AND FIRMWARE*..... 8

 6.5. *WORST-CASE CONFIGURATION AND MODE*..... 9

 6.6. *DESCRIPTION OF TEST SETUP*..... 10

7. MEASUREMENT METHOD..... 13

8. TEST AND MEASUREMENT EQUIPMENT 14

9. ANTENNA PORT TEST RESULTS 16

 9.1. *ON TIME AND DUTY CYCLE*..... 16

 9.2. *99% BANDWIDTH*..... 18

 9.2.1. 802.11b MODE 1TX..... 19

 9.2.2. 802.11n HT20 MODE 21

 9.2.3. 802.11n HT20 CDD MODE 23

 9.2.4. 802.11ax HE20 MODE 24

 9.2.5. 802.11ax HE20 OFDMA MODE 2TX 32

 9.3. *6dB BANDWIDTH*..... 36

 9.3.1. 802.11b MODE 1TX..... 37

 9.3.2. 802.11ax HE20 MODE 39

 9.3.3. 802.11ax HE20 OFDMA MODE 2TX 45

 9.4. *OUTPUT POWER*..... 48

 9.4.1. 802.11b MODE 1TX..... 49

 9.4.2. 802.11n HT20 MODE 51

 9.4.3. 802.11n HT20 CDD MODE 2TX 53

 9.4.4. 802.11ax HE20 MODE 54

 9.4.5. 802.11ax HE20 OFDMA MODE 2TX 62

 9.5. *POWER SPECTRAL DENSITY*..... 66

9.5.1.	802.11b MODE 1TX.....	67
9.5.2.	802.11n HT20 MODE	69
9.5.3.	802.11n HT20 CDD MODE 2TX	71
9.5.4.	802.11ax HE20 MODE	72
9.5.5.	802.11ax HE20 OFDMA MODE 2TX	80
9.6.	<i>CONDUCTED SPURIOUS EMISSIONS</i>	84
9.6.1.	802.11b MODE 1TX.....	85
9.6.2.	802.11n HT20 MODE	89
9.6.3.	802.11n HT20 MODE 2TX.....	95
9.6.4.	802.11ax HE20 MODE	101
9.6.5.	802.11ax HE20 OFDMA MODE 2TX	125
10.	RADIATED TEST RESULTS	151
10.1.	<i>TRANSMITTER ABOVE 1 GHz</i>	153
10.1.1.	TX ABOVE 1 GHz 802.11b MODE IN THE 2.4 GHz BAND	153
10.1.2.	TX ABOVE 1 GHz 802.11n HT20 MODE IN THE 2.4 GHz BAND.....	181
10.1.3.	TX ABOVE 1 GHz 802.11ax HE20 MODE IN THE 2.4 GHz BAND.....	231
10.1.4.	TX ABOVE 1 GHz 802.11ax HE20 OFDMA MODE IN THE 2.4 GHz BAND	295
10.2.	<i>WORST CASE BELOW 1 GHz</i>	335
10.3.	<i>WORST CASE 18-26 GHz</i>	337
11.	AC POWER LINE CONDUCTED EMISSIONS	339
11.1.	<i>AC POWER LINE HOST</i>	340
11.2.	<i>AC POWER LINE NORM</i>	342
12.	SETUP PHOTOS	344

1. ATTESTATION OF TEST RESULTS

COMPANY NAME: APPLE INC.
1 APPLE PARK WAY
CUPERTINO, CA 95014, U.S.A.

EUT DESCRIPTION: Smartphone

MODEL: A2172

SERIAL NUMBER: G6TCN05SQ5HH, G6TCN01JQ5HL

DATE TESTED: FEBUARY 19, 2020 – AUGUST 21, 2020

APPLICABLE STANDARDS	
STANDARD	TEST RESULTS
CFR 47 Part 15 Subpart C	Complies
ISED RSS-247 Issue 2	Complies
ISED RSS-GEN Issue 5	Complies

UL Verification Services Inc. tested the above equipment in accordance with the requirements set forth in the above standards. The test results show that the equipment tested is capable of demonstrating compliance with the requirements as documented in this report.

The results documented in this report apply only to the tested sample, under the conditions and modes of operation as described herein. It is the manufacturer's responsibility to assure that additional production units of this model are manufactured with identical electrical and mechanical components. All samples tested were in good operating condition throughout the entire test program. Measurement Uncertainties are published for informational purposes only and were not taken into account unless noted otherwise.

This document may not be altered or revised in any way unless done so by UL Verification Services Inc. and all revisions are duly noted in the revisions section. Any alteration of this document not carried out by UL Verification Services Inc. will constitute fraud and shall nullify the document. This report must not be used by the client to claim product certification, approval, or endorsement by NVLAP, NIST, any agency of the Federal Government, or any agency of the U.S. government.

Approved & Released For
UL Verification Services Inc. By:

Prepared By:



Chin Pang
Senior Engineer
Consumer Technology Division
UL Verification Services Inc.

Tony Li
Test Engineer
Consumer Technology Division
UL Verification Services Inc.

2. TEST RESULTS SUMMARY

FCC Clause	ISED Clause	Requirement	Result	Comment
See Comment		Duty Cycle	Reporting purposes only	ANSI C63.10 Section 11.6.
-	RSS-GEN 6.7	99% OBW	Reporting purposes only	ANSI C63.10 Section 6.9.3.
15.247 (a) (2)	RSS-247 5.2 (a)	6dB BW	Complies	None.
15.247 (b) (3)	RSS-247 5.4 (d)	Output Power	Complies	None.
See Comment		Average power	Reporting purposes only	Per ANSI C63.10, Section 11.9.2.3.2.
15.247 (e)	RSS-247 5.2 (b)	PSD	Complies	None.
15.247 (d)	RSS-247 5.5	Conducted Spurious Emissions	Complies	None.
15.209, 15.205	RSS-GEN 8.9, 8.10	Radiated Emissions	Complies	None.
15.207	RSS-Gen 8.8	AC Mains Conducted Emissions	Complies	None.

3. TEST METHODOLOGY

The tests documented in this report were performed in accordance with;

- FCC CFR 47 Part 2
- FCC CFR 47 Part 15
- FCC KDB 558074 D01 v05r02 15.247 Meas Guidance
- ANSI C63.10-2013
- RSS-GEN Issue 5
- RSS-247 Issue 2

4. FACILITIES AND ACCREDITATION

The test sites and measurement facilities used to collect data are located at 47173 and 47266 Benicia Street, and 47658 Kato Road, Fremont, California, USA. Line conducted emissions are measured only at the 47173 address. The following table identifies which facilities were utilized for radiated emission measurements documented in this report. Specific facilities are also identified in the test results sections.

47173 Benicia Street	47266 Benicia Street	47658 Kato Rd.
<input type="checkbox"/> Chamber A (IC:2324B-1)	<input type="checkbox"/> Chamber D (IC:22541-1)	<input checked="" type="checkbox"/> Chamber I (IC: 2324A-5)
<input type="checkbox"/> Chamber B (IC:2324B-2)	<input checked="" type="checkbox"/> Chamber E (IC:22541-2)	<input type="checkbox"/> Chamber J (IC: 2324A-6)
<input type="checkbox"/> Chamber C (IC:2324B-3)	<input type="checkbox"/> Chamber F (IC:22541-3)	<input checked="" type="checkbox"/> Chamber K (IC: 2324A-1)
	<input type="checkbox"/> Chamber G (IC:22541-4)	<input checked="" type="checkbox"/> Chamber L (IC: 2324A-3)
	<input checked="" type="checkbox"/> Chamber H (IC:22541-5)	<input type="checkbox"/> Chamber M (IC: 2324A-2)

The above test sites and facilities are covered under FCC Test Firm Registration # 208313. Chambers above are covered under Industry Canada company address and respective code: 2324A.

UL Verification Services Inc. is accredited by NVLAP, Laboratory Code 200065-0

5. DECISION RULES AND MEASUREMENT UNCERTAINTY

5.1. METROLOGICAL TRACEABILITY

All test and measuring equipment utilized to perform the tests documented in this report are calibrated on a regular basis, with a maximum time between calibrations of one year or the manufacturers' recommendation, whichever is less, and where applicable is traceable to recognized national standards.

5.2. DECISION RULES

The Decision Rule is based on Simple Acceptance in accordance with ISO Guide 98-4:2012 Clause 8.2. (Measurement uncertainty is not taken into account when stating conformity with a specified requirement.)

5.3. MEASUREMENT UNCERTAINTY

Where relevant, the following measurement uncertainty levels have been estimated for tests performed on the apparatus:

PARAMETER	U _{LAB}
Worst Case Conducted Disturbance, 9KHz to 0.15 MHz	3.39 dB
Worst Case Conducted Disturbance, 0.15 to 30 MHz	3.07 dB
Worst Case Radiated Disturbance, 9KHz to 30 MHz	2.52 dB
Worst Case Radiated Disturbance, 30 to 1000 MHz	4.88 dB
Worst Case Radiated Disturbance, 1000 to 18000 MHz	4.24 dB
Worst Case Radiated Disturbance, 18000 to 26000 MHz	4.37 dB
Worst Case Radiated Disturbance, 26000 to 40000 MHz	5.17 dB

Uncertainty figures are valid to a confidence level of 95%.

6. EQUIPMENT UNDER TEST

6.1. EUT DESCRIPTION

The Apple iPhone is a smartphone with multimedia functions (music, application support, and video), cellular GSM, GPRS, EGPRS, UMTS, LTE, 5G, CDMA, IEEE 802.11a/b/g/n/ac/ax, Bluetooth, Ultra-Wideband, GPS, NFC and WPT. All models support at least one UICC based SIM. The second SIM is either an UICC based p-SIM (physical SIM) or e-SIM (electronic SIM). The device supports a built-in inductive charging transmitter and receiver. The rechargeable battery is not user accessible.

6.2. MAXIMUM OUTPUT POWER

The transmitter has a maximum conducted output power as follows:

Frequency Range (MHz)	Mode	Output Power (dBm)	Output Power (mW)
1Tx			
2412 - 2472	802.11b	22.40	173.78
	802.11g	Covered by 802.11n HT20 1TX	
	802.11n HT20	21.46	139.96
	802.11ax HE20	21.48	140.60

2Tx			
2412 - 2472	802.11n HT20 CDD	24.26	266.69
	802.11g SDM/STBC	Covered by 802.11n HT20 2TX CDD	
	802.11ax HE20	24.21	263.63

6.3. DESCRIPTION OF AVAILABLE ANTENNAS

Frequency Range (GHz)	ANT 4 (dBi)	ANT 3 (dBi)
2.4	-2.1	-0.3

6.4. SOFTWARE AND FIRMWARE

The EUT firmware installed during testing was WiFi FW Version: WiFi: 20_10_619_14

6.5. WORST-CASE CONFIGURATION AND MODE

EUT was investigated in three orthogonal orientations X, Y and Z on ANT4, ANT3 and 2TX. It was determined that X (Flatbed) orientation was worst-case orientation for both ANT4 and 2TX and Z (Portrait) orientation for ANT 3.

Radiated band edge, harmonic, and spurious emissions from 1GHz to 18GHz were performed with the EUT set to transmit at highest power on Low/Middle/High channels.

Radiated emissions below 1GHz, 18-26GHz and power line conducted emissions were performed with the EUT transmits at the channel with the highest output power as worst-case scenario.

For radiated harmonics spurious below 1GHz, 1-18GHz L/M/H channels, 18-26GHz, and power line conducted emissions were performed with the EUT set at the 2TX CDD mode among the CDD/SDM modes and 2TX HE mode with power setting equal or higher than SISO modes as worst-case scenario. G mode covered by HT20 mode since it has the same power as HT20.

Below 1GHz tests were performed with EUT connected to AC power adapter as the worst case; and for above 1GHz tests, the worst-case configuration reported was with EUT only. For AC line conducted emission, test was investigated with AC power adapter and with laptop. There were no emissions found below 30MHz within 20dB of the limit.

The output power and psd for the 802.11 ax mode were investigated between all different tones, and we found that the highest tone had the highest output power and PSD readings, the lowest tone had the highest PSD readings. Therefore, full testing was performed on both the highest and lowest tones.

The PSD were performed as worst case mode.

Worst-case data rates as provided by the client were:

802.11b mode: 1 Mbps
802.11n HT20mode: MCS7 for Band Edge
802.11ax HE20mode: MCS9 for Band Edge

There are two vendors of the WiFi/Bluetooth radio modules: variant 1 and variant 2. The Wi-Fi/Bluetooth radio modules have the same mechanical outline (e.g., the same package dimension and pin-out layout), use the same on-board antenna matching circuit, have an identical antenna structure, and are built and tested to conform to the same specifications and to operate within the same tolerances.

Baseline testing was performed on the two variants to determine the worst case on all conducted power and radiated emissions.

6.6. DESCRIPTION OF TEST SETUP

SUPPORT TEST EQUIPMENT						
Description	Manufacturer	Model	Serial Number	FCC ID/ DoC		
Laptop	Apple	A1398	C02PM012G3QD	DQS-BRCM1069		
Laptop AC/DC adapter	Liteon Technology	PA-1450-BA1	B123	N/A		
EUT AC/DC adapter	Apple	A1385	D29325SM03XDHLHC9	N/A		
I/O CABLES (RF CONDUCTED TEST)						
Cable No.	Port	# of Identical Ports	Connector Type	Cable Type	Cable Length (m)	Remarks
1	Antenna	1	SMA	Un-shielded	0.2	To spectrum Analyzer
2	USB	1	USB	Shielded	1.0	N/A
3	AC	1	AC	Un-shielded	2	N/A
I/O CABLES (RF RADIATED TEST)						
Cable No.	Port	# of Identical Ports	Connector Type	Cable Type	Cable Length (m)	Remarks
1	AC	1	AC	Un-shielded	2	N/A
2	USB	1	USB	Un-shielded	1	N/A

TEST SETUP

The EUT setup is shown as below. Test software exercised the radio card.

SETUP DIAGRAM FOR CONDUCTED TESTS

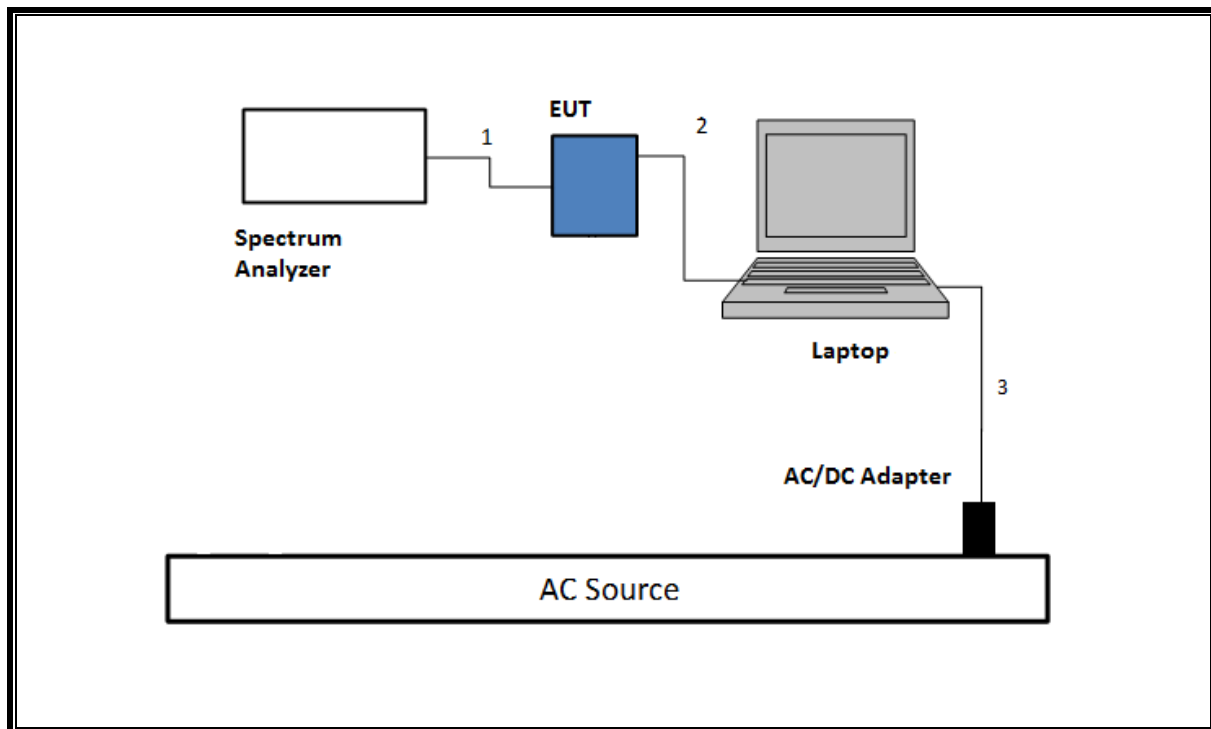

SETUP DIAGRAM FOR RADIATED TESTS Above 1 GHz

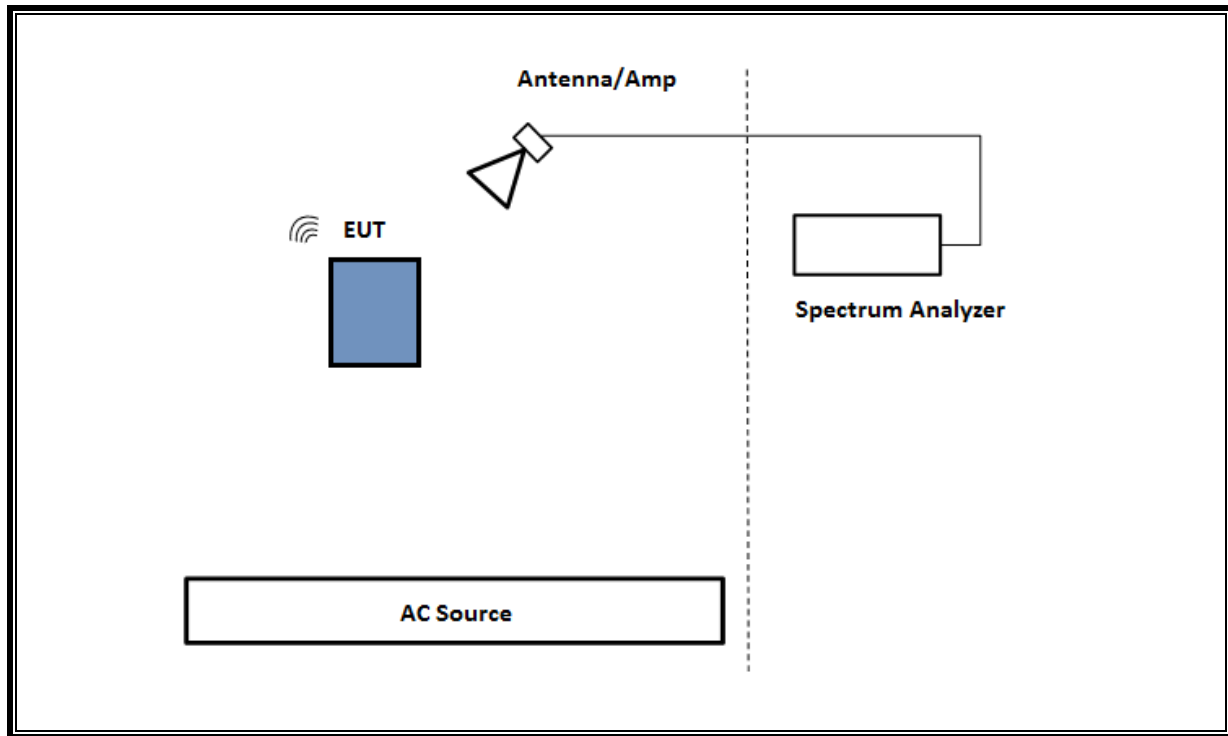

SETUP DIAGRAM FOR Below 1GHz and AC LINE CONDUCTED TEST

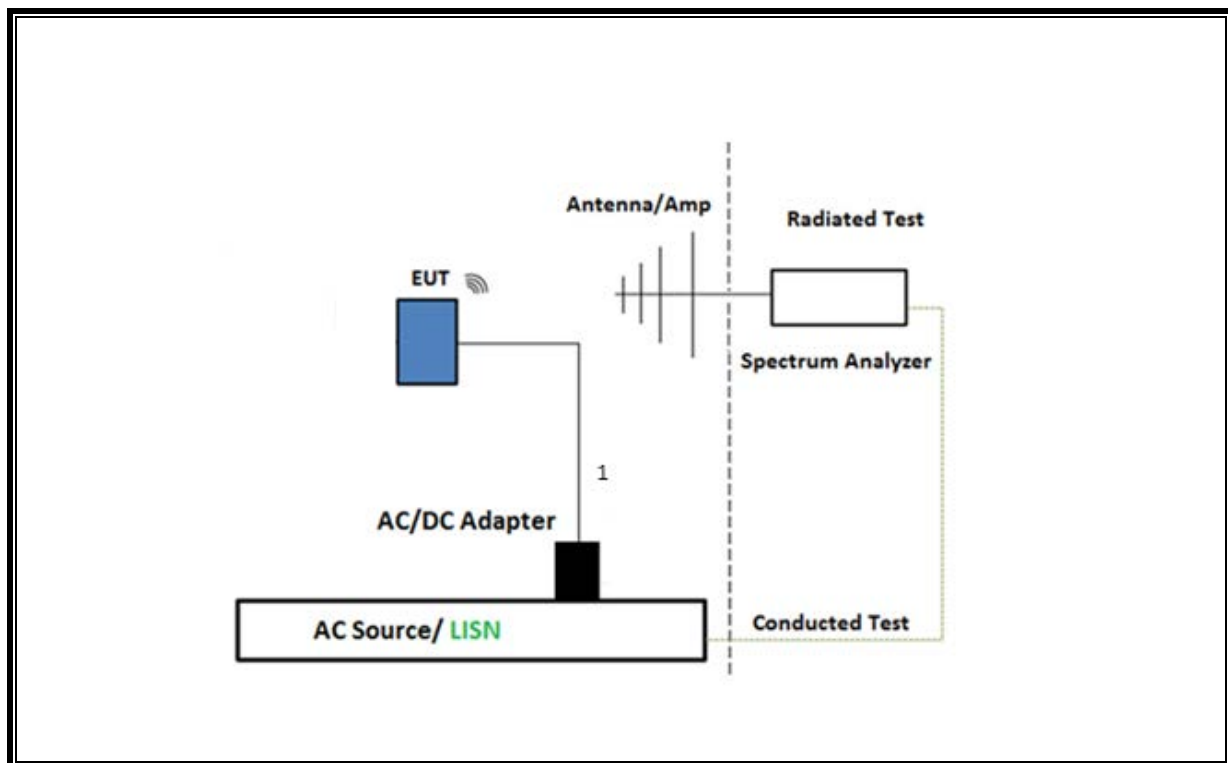

TEST SETUP- AC LINE CONDUCTED: LAPTOP CONFIGURATION

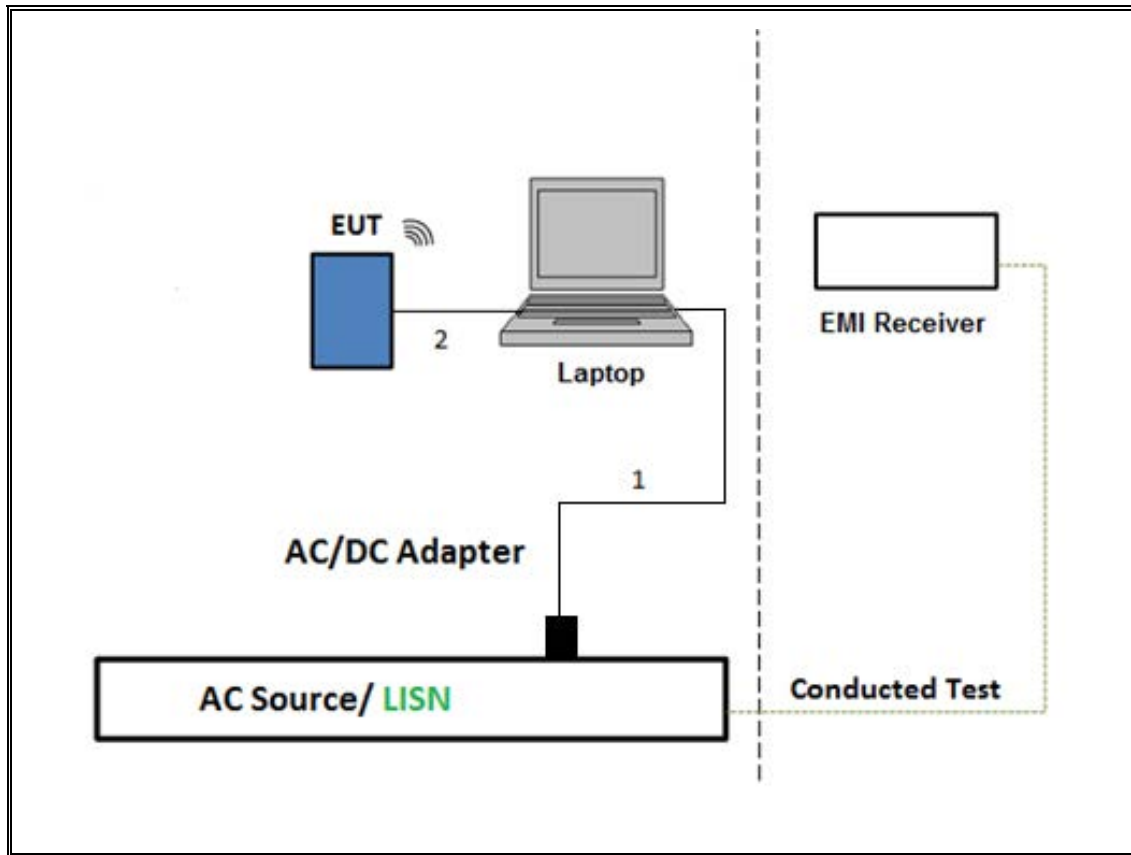

7. MEASUREMENT METHOD

Test Item	Test Method
6 dB BW	ANSI C63.10 Subclause -11.8.1 RBW \geq DTS BW
99% BW	ANSI C63.10-2013, Subclause 6.9.3.
Output Power	ANSI C63.10 Subclause -11.9.2.3.1 Method AVGPM (Measurement using an RF gated average-reading power meter)
PSD	ANSI C63.10 Subclause -11.10.3 Method AVGPSD-1
Radiated emissions non-restricted frequency bands	ANSI C63.10 Subclause -11.11 & Clause 13
Radiated emissions restricted frequency bands	ANSI C63.10 Subclause -11.12.1 & Clause 13
Conducted emissions in restricted frequency bands	ANSI C63.10 Subclause -11.12.2
Band-edge	ANSI C63.10 Subclause -11.13.3.2 & Clause 13: Integration method -Peak detection
Band-edge	ANSI C63.10 Subclause -11.13.3.3 & Clause 13: Integration method -Trace averaging with continuous transmission at full power
Radiated Spurious Emissions Below 30MHz	ANSI C63.10-2013 Subclause 6.4 & Clause 13
AC Power Line Conducted Emissions	ANSI C63.10-2013, Subclause 6.2

8. TEST AND MEASUREMENT EQUIPMENT

The following test and measurement equipment was utilized for the tests documented in this report:

TEST EQUIPMENT LIST					
Description	Manufacturer	Model	ID Num	Cal Due	Last Cal
Antenna, Horn 1-18GHz	ETS-Lindgren	3117	T712	03/09/2021	03/09/2020
Amplifier, 1 to 18GHz, 35dB	Miteq	AFS42-00101800-25-S-42	138301	03/03/2021	03/03/2020
Spectrum Analyzer, PXA, 3Hz to 44GHz	Agilent (Keysight) Technologies	N9030A	T1466	01/23/2021	01/23/2020
Antenna, Horn 1-18GHz	ETS-Lindgren	3117	T863	11/01/2020	11/01/2019
Amplifier, 1 to 18GHz, 35dB	Miteq	AFS42-00101800-25-S-42	T1567	01/24/2021	01/24/2020
Spectrum Analyzer, PXA, 3Hz to 44GHz	Agilent (Keysight) Technologies	N9030A	T1210	01/21/2021	01/21/2020
Antenna, Horn 1-18GHz	ETS-Lindgren	3117	EMC4294	11/01/2020	11/01/2019
Amplifier, 100MHz - 18GHz	AMPLICAL	AMP0, 1G18-47-20	PRE0197319	05/04/2021	05/04/2020
EMI Test Receiver	Rohde & Schwarz	ESW44	PRE0179376	04/03/2021	04/03/2020
Antenna, Horn 1-18GHz	ETS-Lindgren	3117	T344	05/26/2021	05/26/2021
Amplifier, 1 to 18GHz, 35dB	Miteq	AFS42-00101800-25-S-42	T1568	04/14/2021	04/14/2020
EMI Test Receiver	Rohde & Schwarz	ESW44	PRE0179367	02/26/2021	02/26/2020
Antenna, Broadband Hybrid, 30MHz to 3000MHz	Sunol Sciences Corp.	JB3	PRE0184052	11/12/2020	11/12/2019
*Amplifier, 9KHz to 1GHz, 32dB	Sonoma	310	PRE0180175	05/29/2020	05/29/2019
EMI Test Receiver	Rohde & Schwarz	ESW44	PRE0179522	02/20/2021	02/20/2020
Antenna Horn, 18 to 26GHz	ARA	SWH-28	T125	04/17/2021	04/17/2020
Pre-Amp 18-26GHz	Agilent Technology	8449B	T404	04/8/2021	04/8/2020
Spectrum Analyzer, PXA, 3Hz to 44GHz	Agilent (Keysight) Technologies	N9030A	T905	01/24/2021	01/24/2020
Spectrum Analyzer, PXA, 3Hz to 44GHz	Agilent (Keysight) Technologies	N9030A	T339	01/21/2021	01/21/2020
Power Meter, P-series single channel	Keysight	N1911A	PRE0177682	01/21/2021	01/21/2020
Power Sensor	Keysight	N1921A	T1226	02/13/2021	02/13/2020
Antenna, Active Loop 9KHz to 30MHz	ETS-Lindgren	6502	T757	10/01/2020	10/01/2019

AC Line Conducted					
Description	Manufacturer	Model	ID Num	Cal Due	Last Cal
EMI Test Receiver 9Khz-7GHz	Rohde & Schwarz	ESCI7	T1436	02/20/2021	02/20/2020
Power Cable, Line Conducted Emissions	UL	PG1	T861	10/27/2020	10/27/2019
LISN for Conducted Emissions CISPR-16	Fischer	50/250-25-2-01	PRE0186446	01/23/2021	01/23/2020
UL AUTOMATION SOFTWARE					
Radiated Software	UL	UL EMC		Rev 9.5, 30 Apr, 2020	
Conducted Software	UL	UL EMC		AP2020.8.6	
AC Line Conducted Software	UL	UL EMC		Rev 9.5, 21 Feb 2020	

*Testing is completed before equipment expiration date.

9. ANTENNA PORT TEST RESULTS

9.1. ON TIME AND DUTY CYCLE

LIMITS

None; for reporting purposes only.

PROCEDURE

KDB 558074 Zero-Span Spectrum Analyzer Method.

ON TIME AND DUTY CYCLE RESULTS

Mode	ON Time B (msec)	Period (msec)	Duty Cycle x (linear)	Duty Cycle (%)	Duty Cycle Correction Factor (dB)	1/B Minimum VBW (kHz)
2.4GHz Band						
802.11b	1.000	1.000	1.000	100.00%	0.00	0.010
802.11n HT20 MCS0	1.920	1.940	0.990	98.97%	0.00	0.010
802.11n HT20 MCS7	0.228	0.248	0.919	91.94%	0.37	4.386
802.11ax HE20 MCS0	1.560	1.580	0.987	98.73%	0.00	0.010
802.11ax HE20 MCS9	1.560	1.580	0.987	98.73%	0.00	0.010

DUTY CYCLE PLOTS



DUTY CYCLE 802.11b MODE



DUTY CYCLE 802.11n HT20 MCS0



DUTY CYCLE 802.11n HT20 MCS7



DUTY CYCLE 802.11ax HE20 MCS0



DUTY CYCLE 802.11ax HE20 MCS9

9.2. 99% BANDWIDTH

LIMITS

None; for reporting purposes only.

RESULTS

Only Mid channel plot is reported to show setting parameter complies with testing method/procedure.

9.2.1. 802.11b MODE 1TX

1TX ANT 4

Channel	Frequency (MHz)	99% Bandwidth (MHz)
Low 1	2412	13.118
Low 2	2417	13.215
Mid 6	2437	13.237
High 7	2442	13.175
High 8	2447	13.099
High 9	2452	13.060
High 10	2457	13.021
High 11	2462	13.156
High 12	2467	13.116
High 13	2472	13.140

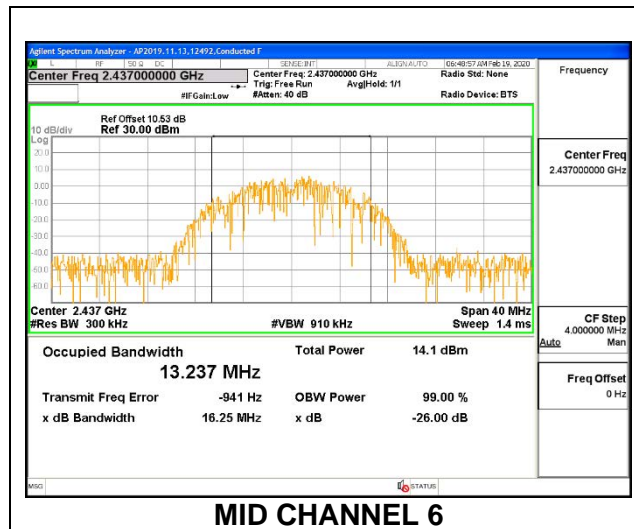

1TX ANT 3 MODE

Channel	Frequency (MHz)	99% Bandwidth (MHz)
Low 1	2412	13.242
Low 2	2417	13.162
Mid 6	2437	13.140
High 7	2442	13.131
High 8	2447	13.452
High 9	2452	13.173
High 10	2457	13.266
High 11	2462	13.377
High 12	2467	13.086
High 13	2472	12.816

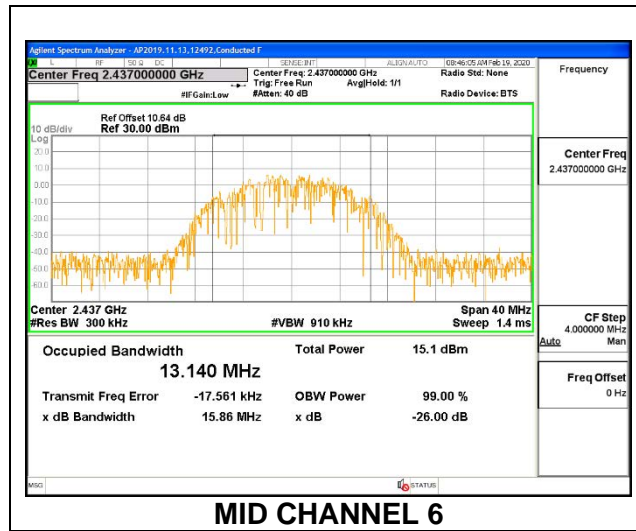

9.2.2. 802.11n HT20 MODE

1TX ANT 4

Channel	Frequency (MHz)	99% Bandwidth (MHz)
Low 1	2412	17.719
Low 2	2417	17.634
Low 3	2422	17.769
Mid 6	2437	17.576
High 9	2452	17.628
High 10	2457	17.735
High 11	2462	17.722
High 12	2467	17.728
High 13	2472	17.546

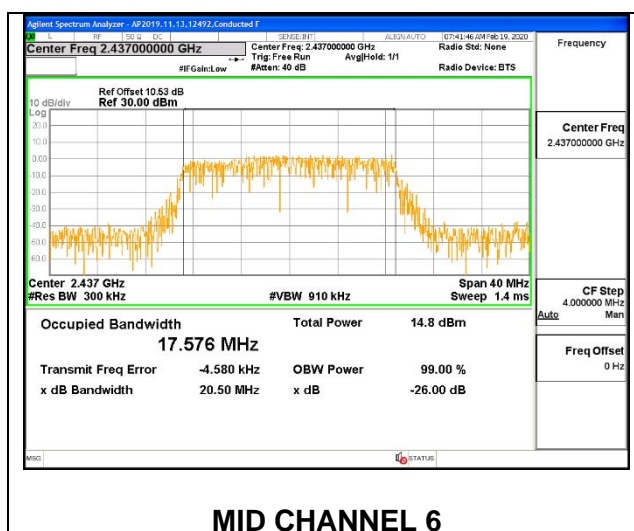

1TX ANT 3 MODE

Channel	Frequency (MHz)	99% Bandwidth (MHz)
Low 1	2412	17.918
Low 2	2417	17.743
Low 3	2422	17.737
Mid 6	2437	17.975
High 9	2452	17.928
High 10	2457	17.897
High 11	2462	17.854
High 12	2467	17.784
High 13	2472	17.649

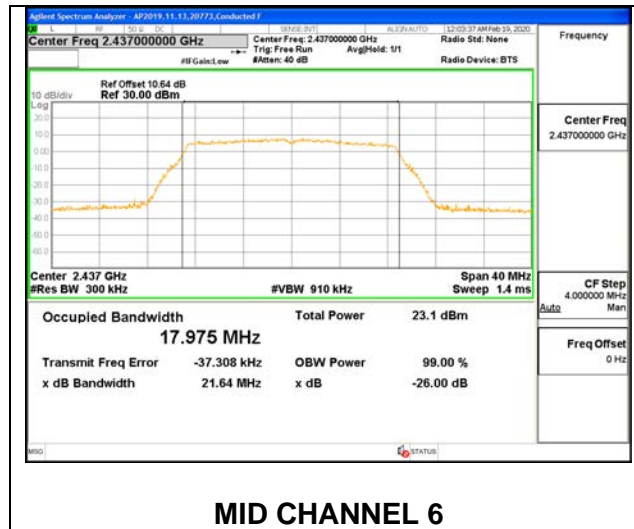

9.2.3. 802.11n HT20 CDD MODE

ANT 4 + ANT 3 2TX

Channel	Frequency (MHz)	99% Bandwidth (MHz) ANT 4	99% Bandwidth (MHz) ANT 3
Low 1	2412	17.680	17.717
Low 2	2417	17.708	17.719
Low 3	2422	17.768	17.825
Low 4	2427	17.718	17.682
Mid 6	2437	17.686	17.677
High 8	2447	17.704	17.764
High 9	2452	17.670	17.621
High 10	2457	17.628	17.645
High 11	2462	17.776	17.770
High 12	2467	17.845	17.607
High 13	2472	17.612	17.434

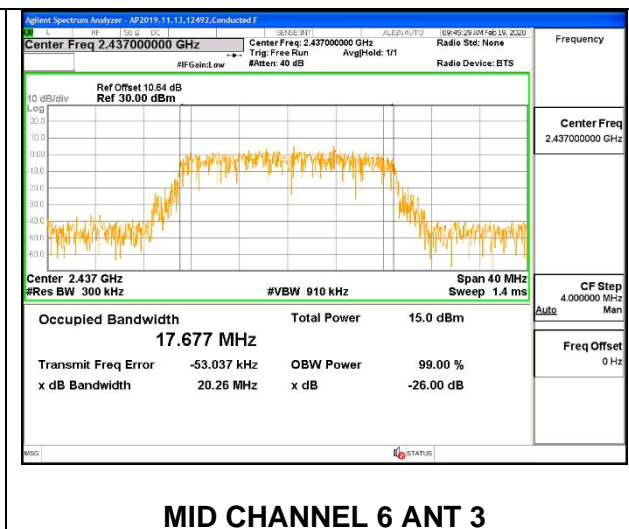
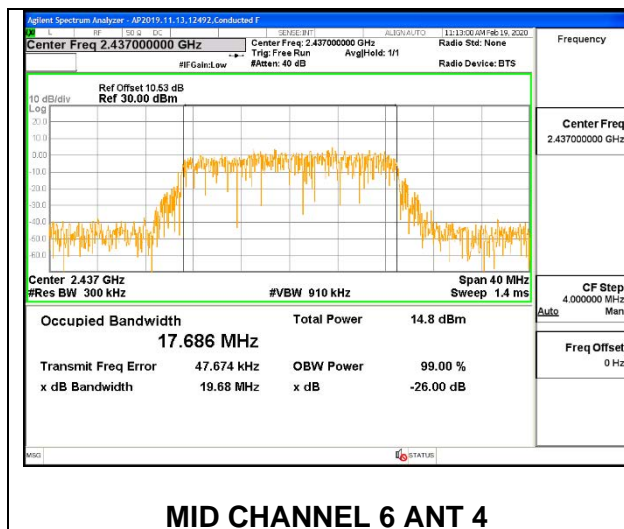

9.2.4. 802.11ax HE20 MODE

ANT 4 LEGACY SISO MODE: 26-Tones, RU index 0

Channel	Frequency (MHz)	99% Bandwidth (MHz)
Low 1	2412	18.333
Low 2	2417	18.433
Low 3	2422	18.484
Mid 6	2437	18.548
High 9	2452	18.221
High 10	2457	18.272
High 11	2462	18.407
High 12	2467	18.489
High 13	2472	18.176

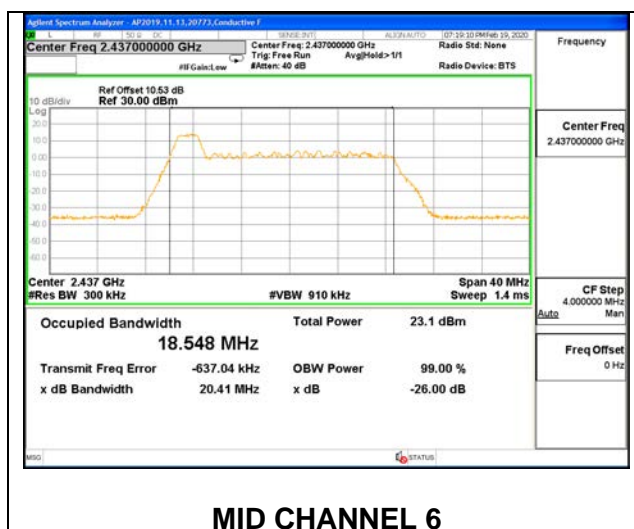

ANT 4 LEGACY SISO MODE: 26-Tones, RU Index 4

Channel	Frequency (MHz)	99% Bandwidth (MHz)
Low 1	2412	17.192
Low 2	2417	17.223
Low 3	2422	17.339
Mid 6	2437	17.158
High 9	2452	17.055
High 10	2457	17.288
High 11	2462	17.140
High 12	2467	17.199
High 13	2472	17.067

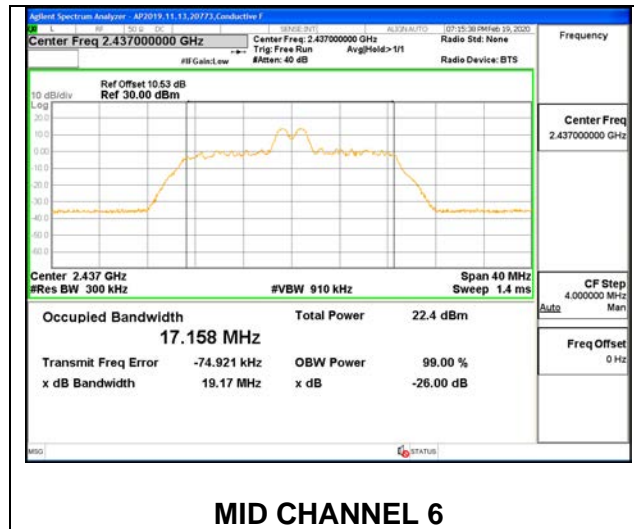

ANT 4 LEGACY SISO MODE: 26-Tones, RU Index 8

Channel	Frequency (MHz)	99% Bandwidth (MHz)
Low 1	2412	18.745
Low 2	2417	18.688
Low 3	2422	18.918
Mid 6	2437	18.718
High 9	2452	18.950
High 10	2457	19.037
High 11	2462	19.049
High 12	2467	18.799
High 13	2472	18.648

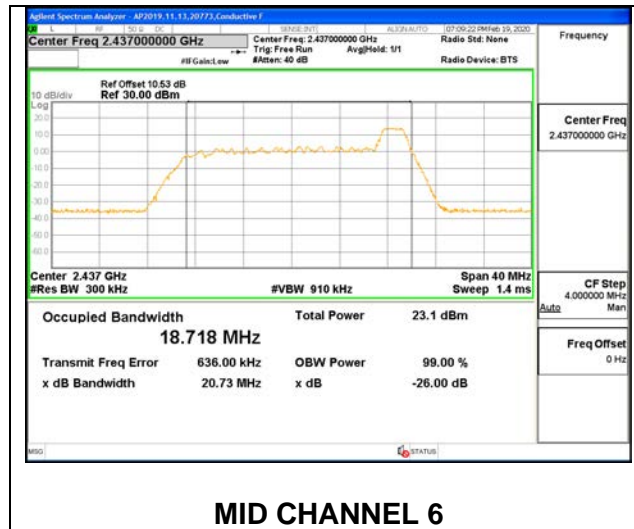

ANT 4 LEGACY SISO MODE: 242-Tones, RU Index 61

Channel	Frequency (MHz)	99% Bandwidth (MHz)
Low 1	2412	18.901
Low 2	2417	18.948
Low 3	2422	18.995
Mid 6	2437	18.925
High 9	2452	18.904
High 10	2457	18.920
High 11	2462	18.974
High 12	2467	18.988
High 13	2472	18.825

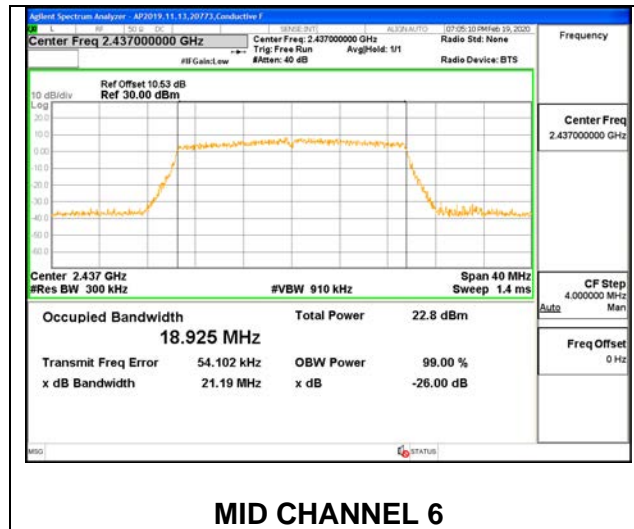

ANT 3 LEGACY SISO MODE: 26-Tones, RU Index 0

Channel	Frequency (MHz)	99% Bandwidth (MHz)
Low 1	2412	18.488
Low 2	2417	18.548
Low 3	2422	18.440
Mid 6	2437	18.444
High 9	2452	18.514
High 10	2457	18.489
High 11	2462	18.504
High 12	2467	18.368
High 13	2472	18.176

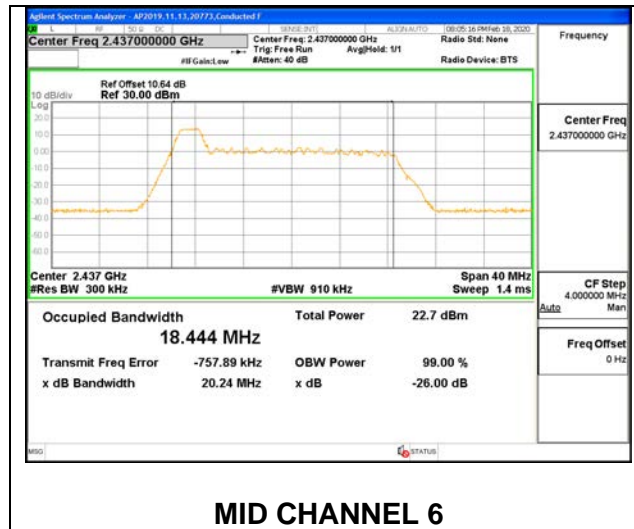

ANT 3 LEGACY SISO MODE: 26-Tones, RU Index 4

Channel	Frequency (MHz)	99% Bandwidth (MHz)
Low 1	2412	17.012
Low 2	2417	16.921
Low 3	2422	17.023
Mid 6	2437	17.157
High 9	2452	17.253
High 10	2457	17.207
High 11	2462	17.131
High 12	2467	17.042
High 13	2472	16.855

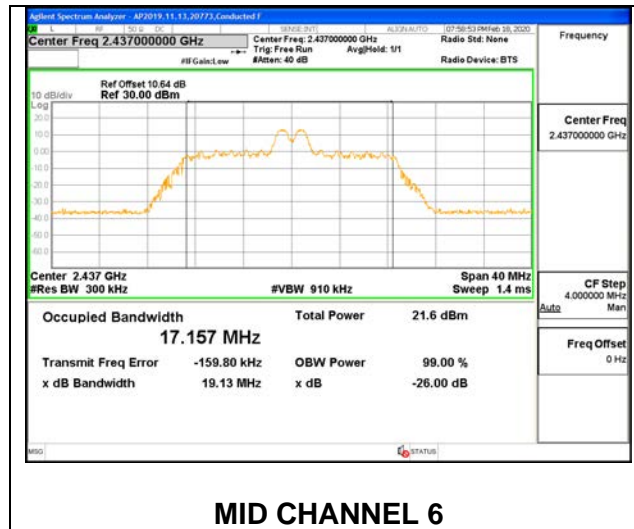

ANT 3 LEGACY SISO MODE: 26-Tones, RU Index 8

Channel	Frequency (MHz)	99% Bandwidth (MHz)
Low 1	2412	18.532
Low 2	2417	18.642
Low 3	2422	18.786
Mid 6	2437	18.947
High 9	2452	18.784
High 10	2457	18.765
High 11	2462	18.670
High 12	2467	18.774
High 13	2472	18.726

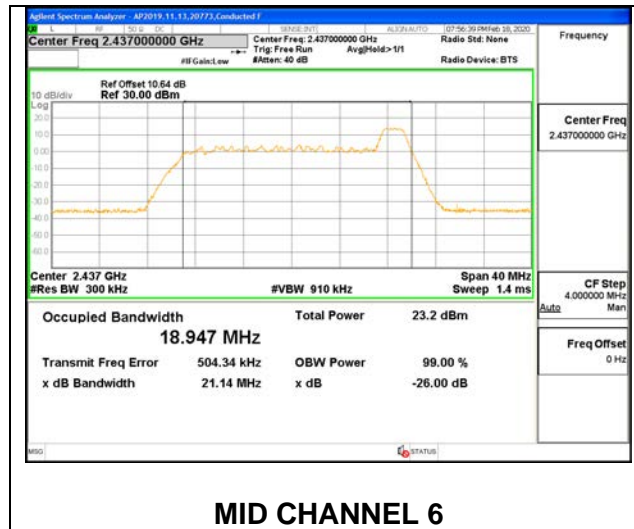

ANT 3 LEGACY SISO MODE: 242-Tones, RU Index 61

Channel	Frequency (MHz)	99% Bandwidth (MHz)
Low 1	2412	18.872
Low 2	2417	18.858
Low 3	2422	18.876
Mid 6	2437	18.938
High 9	2452	18.975
High 10	2457	18.949
High 11	2462	18.937
High 12	2467	18.892
High 13	2472	18.823

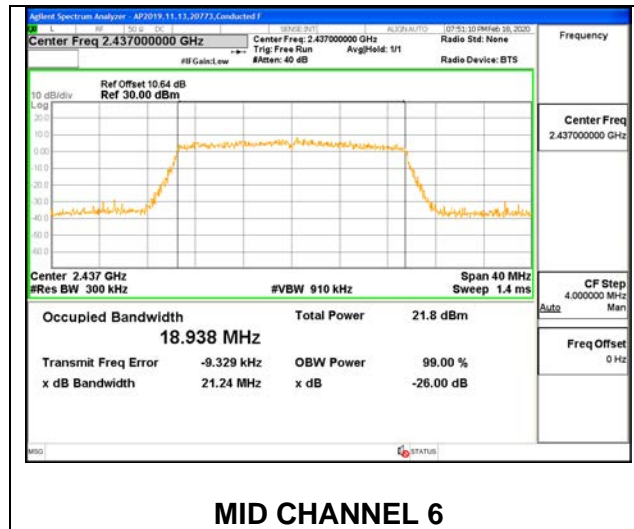

9.2.5. 802.11ax HE20 OFDMA MODE 2TX

ANT 4 + ANT 3 2TX MODE: 26-Tones, RU Index 0

Channel	Frequency (MHz)	99% Bandwidth (MHz) ANT 4	99% Bandwidth (MHz) ANT 3
Low 1	2412	18.283	18.464
Low 2	2417	18.466	18.483
Low 3	2422	18.456	18.459
Mid 6	2437	18.446	18.190
High 9	2452	18.132	18.376
High 10	2457	18.161	18.467
High 11	2462	18.332	18.442
High 12	2467	18.501	18.347
High 13	2472	18.172	17.961

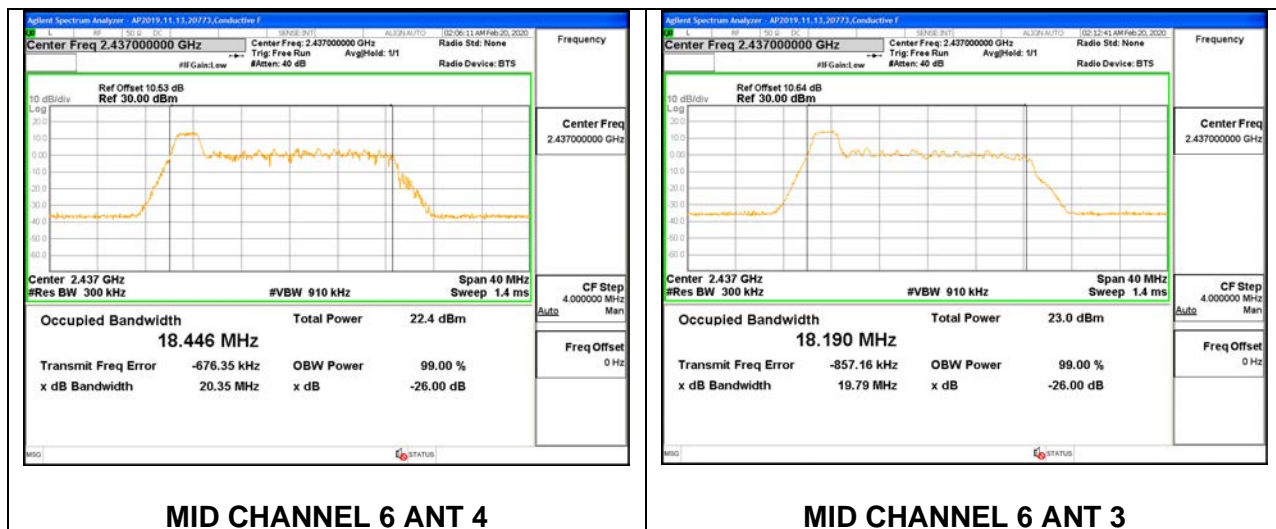

ANT 4 + ANT 3 2TX MODE: 26-Tones, RU Index 4

Channel	Frequency (MHz)	99% Bandwidth (MHz) ANT 4	99% Bandwidth (MHz) ANT 3
Low 1	2412	17.069	16.766
Low 2	2417	17.336	16.679
Low 3	2422	17.250	16.658
Mid 6	2437	17.049	17.150
High 9	2452	17.163	16.956
High 10	2457	17.159	16.936
High 11	2462	17.274	16.708
High 12	2467	17.222	16.430
High 13	2472	16.885	16.192

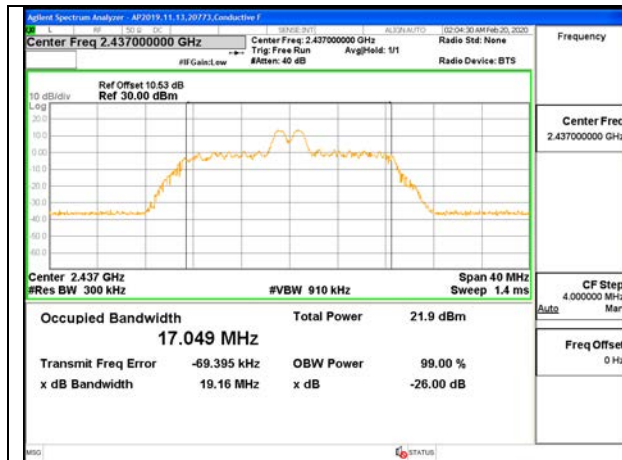

MID CHANNEL 6 ANT 4

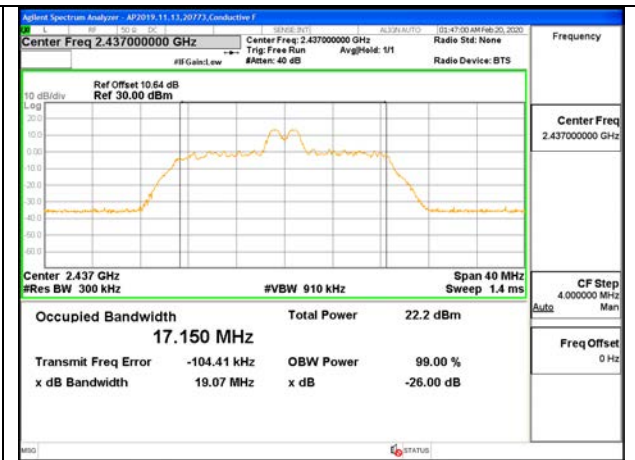

MID CHANNEL 6 ANT 3

ANT 4 + ANT 3 2TX MODE: 26-Tones, RU Index 8

Channel	Frequency (MHz)	99% Bandwidth (MHz) ANT 4	99% Bandwidth (MHz) ANT 3
Low 1	2412	18.802	18.261
Low 2	2417	18.800	18.120
Low 3	2422	18.729	18.182
Mid 6	2437	18.529	18.518
High 9	2452	19.001	18.555
High 10	2457	18.891	18.413
High 11	2462	18.918	18.175
High 12	2467	18.675	18.357
High 13	2472	18.670	18.400

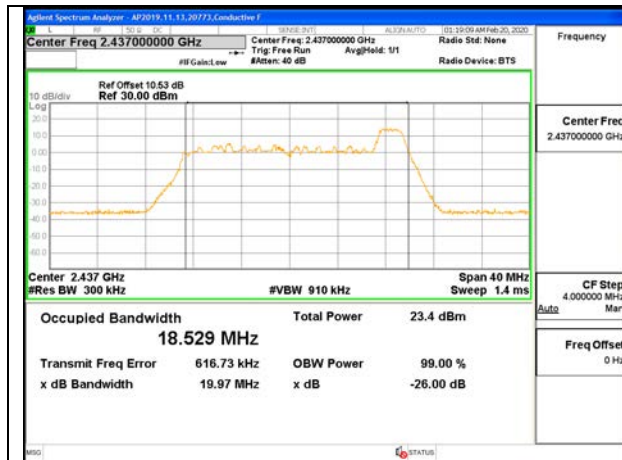

MID CHANNEL 6 ANT 4

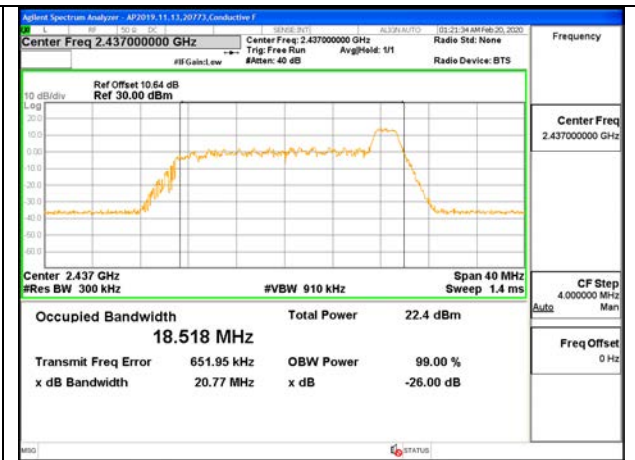

MID CHANNEL 6 ANT 3

ANT 4 + ANT 3 2TX MODE: 242-Tones, RU Index 61

Channel	Frequency (MHz)	99% Bandwidth (MHz) ANT 4	99% Bandwidth (MHz) ANT 3
Low 1	2412	18.895	18.930
Low 2	2417	18.989	18.940
Low 3	2422	18.982	18.979
Low 4	2427	18.831	18.873
Mid 6	2437	18.926	18.890
High 8	2447	19.000	18.832
High 9	2452	18.876	18.985
High 10	2457	18.926	18.989
High 11	2462	18.876	18.985
High 12	2467	18.926	18.989
High 13	2472	19.009	18.925



MID CHANNEL 6 ANT 4



MID CHANNEL 6 ANT 3

9.3. 6dB BANDWIDTH

LIMITS

FCC §15.247 (a) (2)

RSS-247 5.2 (a)

The minimum 6 dB bandwidth shall be at least 500 kHz.

RESULTS

The 6dB bandwidth was measured for the narrowest bandwidth mode, b Mode and ax HE20 Mode 26-Tones as worst case to demonstrate compliance with the minimum required bandwidth of 500 kHz to cover all OFDMA modes.

Only Mid channel plot is reported to show setting parameter complies with testing method/procedure.

9.3.1. 802.11b MODE 1TX

1TX ANT 4 MODE

Channel	Frequency (MHz)	6dB Bandwidth (MHz)	Minimum Limit (MHz)
Low 1	2412	8.80	0.5
Low 2	2417	8.68	0.5
Mid 6	2437	8.64	0.5
High 7	2442	8.12	0.5
High 8	2447	8.16	0.5
High 9	2452	7.20	0.5
High 10	2457	7.16	0.5
High 11	2462	7.60	0.5
High 12	2467	7.72	0.5
High 13	2472	7.20	0.5

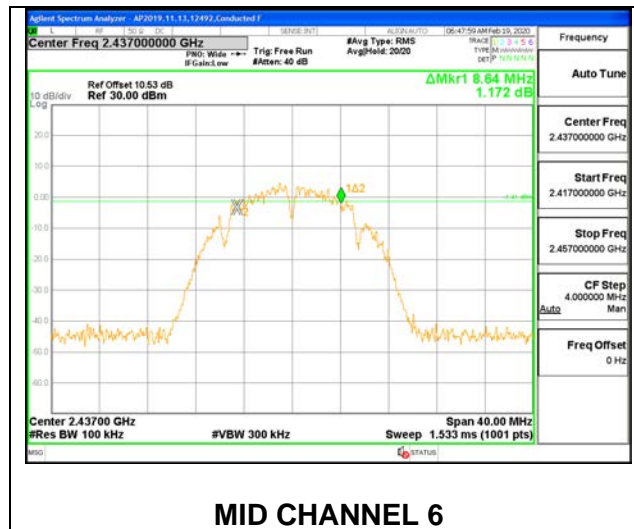

1TX ANT 3 MODE

Channel	Frequency (MHz)	6dB Bandwidth (MHz)	Minimum Limit (MHz)
Low 1	2412	7.24	0.5
Low 2	2417	7.52	0.5
Mid 6	2437	7.68	0.5
High 7	2442	7.60	0.5
High 8	2447	7.68	0.5
High 9	2452	7.24	0.5
High 10	2457	7.76	0.5
High 11	2462	7.72	0.5
High 12	2467	7.67	0.5
High 13	2472	7.68	0.5

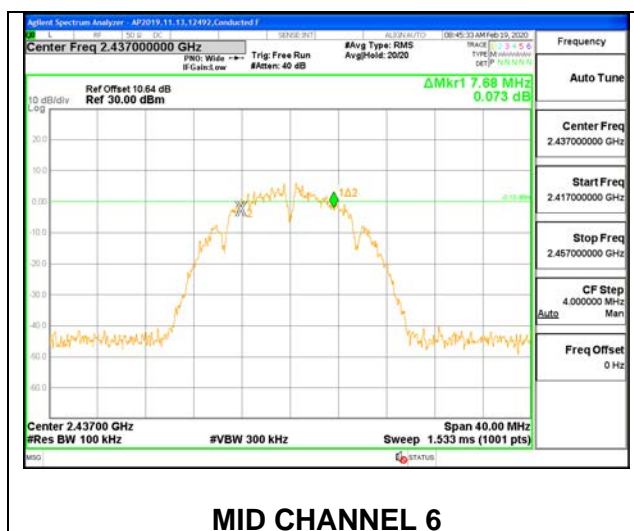

9.3.2. 802.11ax HE20 MODE

ANT 4 LEGACY SISO MODE: 26-Tones, RU index 0

Channel	Frequency (MHz)	6dB Bandwidth (MHz)	Minimum Limit (MHz)
Low 1	2412	2.04	0.5
Low 2	2417	2.12	0.5
Low 3	2422	2.08	0.5
Mid 6	2437	2.16	0.5
High 9	2452	2.12	0.5
High 10	2457	2.12	0.5
High 11	2462	2.08	0.5
High 12	2467	2.08	0.5
High 13	2472	2.80	0.5

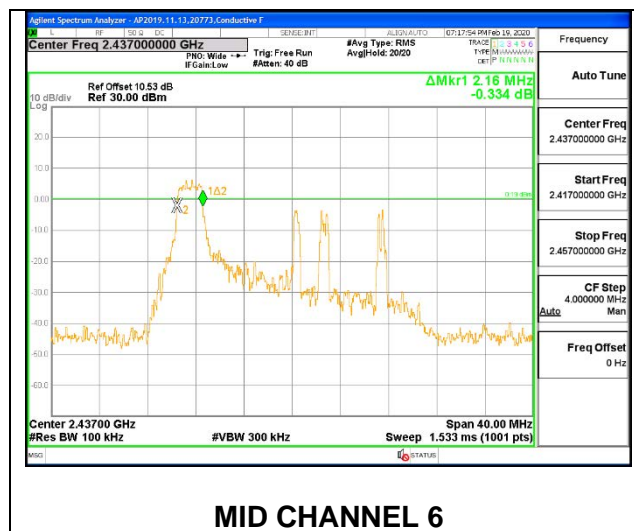

ANT 4 LEGACY SISO MODE: 26-Tones, RU Index 4

Channel	Frequency (MHz)	6dB Bandwidth (MHz)	Minimum Limit (MHz)
Low 1	2412	2.68	0.5
Low 2	2417	2.64	0.5
Low 3	2422	2.60	0.5
Mid 6	2437	2.72	0.5
High 9	2452	2.68	0.5
High 10	2457	2.68	0.5
High 11	2462	2.68	0.5
High 12	2467	2.68	0.5
High 13	2472	2.72	0.5

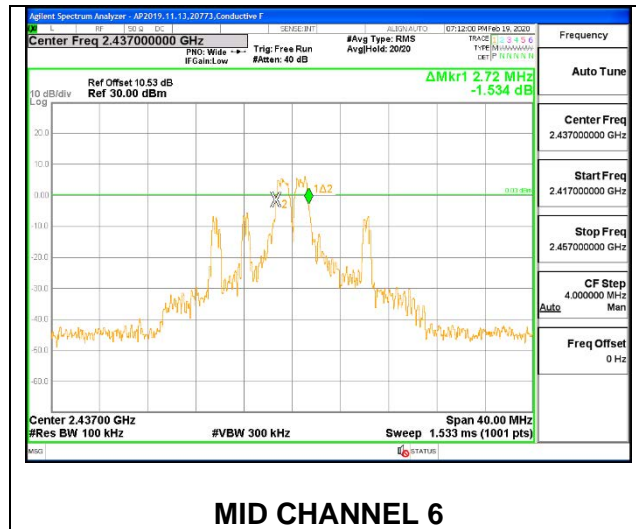

ANT 4 LEGACY SISO MODE: 26-Tones, RU Index 8

Channel	Frequency (MHz)	6dB Bandwidth (MHz)	Minimum Limit (MHz)
Low 1	2412	2.16	0.5
Low 2	2417	2.12	0.5
Low 3	2422	2.08	0.5
Mid 6	2437	2.08	0.5
High 9	2452	2.12	0.5
High 10	2457	2.08	0.5
High 11	2462	2.04	0.5
High 12	2467	2.16	0.5
High 13	2472	2.08	0.5

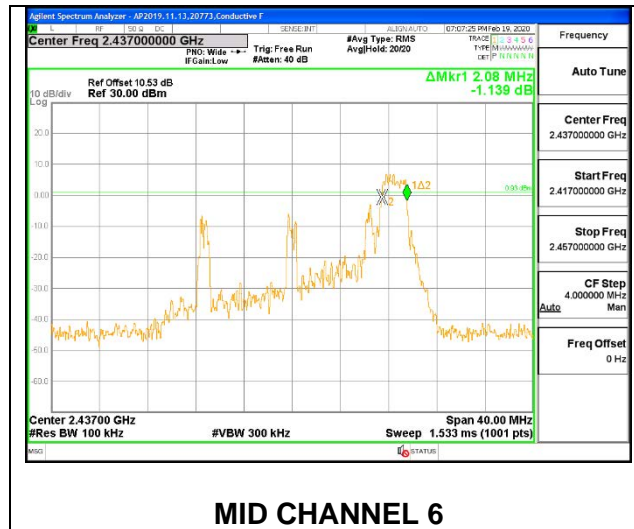

ANT 3 LEGACY SISO MODE: 26-Tones, RU Index 0

Channel	Frequency (MHz)	6dB Bandwidth (MHz)	Minimum Limit (MHz)
Low 1	2412	2.12	0.5
Low 2	2417	2.12	0.5
Low 3	2422	2.20	0.5
Mid 6	2437	2.08	0.5
High 9	2452	2.08	0.5
High 10	2457	2.08	0.5
High 11	2462	2.08	0.5
High 12	2467	2.08	0.5
High 13	2472	2.16	0.5

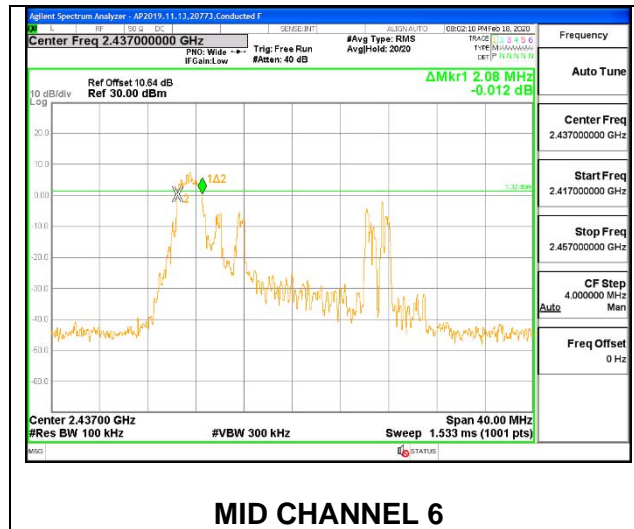

ANT 3 LEGACY SISO MODE: 26-Tones, RU Index 4

Channel	Frequency (MHz)	6dB Bandwidth (MHz)	Minimum Limit (MHz)
Low 1	2412	2.60	0.5
Low 2	2417	2.64	0.5
Low 3	2422	2.68	0.5
Mid 6	2437	2.60	0.5
High 9	2452	2.64	0.5
High 10	2457	2.68	0.5
High 11	2462	2.64	0.5
High 12	2467	2.72	0.5
High 13	2472	2.64	0.5

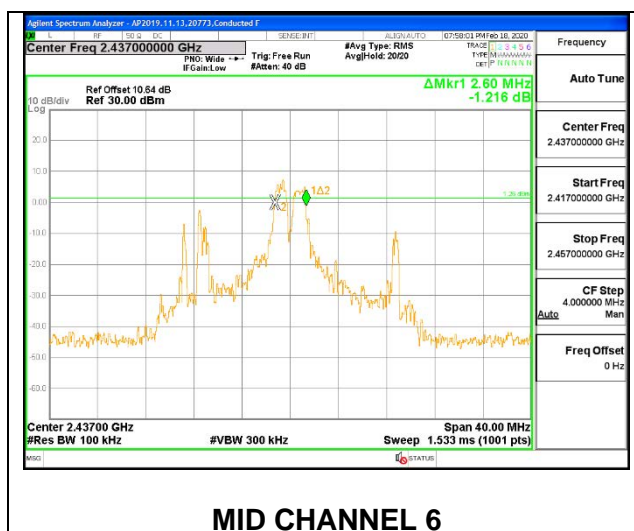

ANT 3 LEGACY SISO MODE: 26-Tones, RU Index 8

Channel	Frequency (MHz)	6dB Bandwidth (MHz)	Minimum Limit (MHz)
Low 1	2412	2.16	0.5
Low 2	2417	2.08	0.5
Low 3	2422	2.08	0.5
Mid 6	2437	2.12	0.5
High 9	2452	2.12	0.5
High 10	2457	2.12	0.5
High 11	2462	2.12	0.5
High 12	2467	2.00	0.5
High 13	2472	2.08	0.5

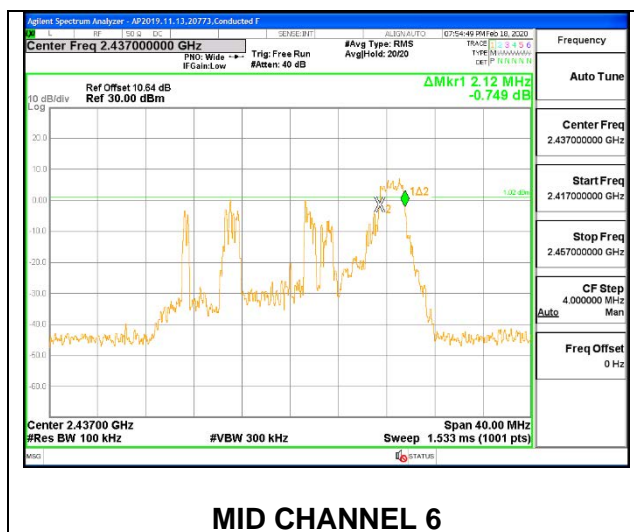

9.3.3. 802.11ax HE20 OFDMA MODE 2TX

ANT 4 + ANT 3 2TX MODE: 26-Tones, RU Index 0

Channel	Frequency (MHz)	6dB BW(MHz) ANT 4	6dB BW (MHz) ANT 3	Minimum Limit (MHz)
Low 1	2412	2.08	2.04	0.5
Low 2	2417	2.08	2.12	0.5
Low 3	2422	2.08	2.08	0.5
Mid 6	2437	2.08	2.20	0.5
High 9	2452	2.08	2.08	0.5
High 10	2457	2.08	2.08	0.5
High 11	2462	2.12	2.20	0.5
High 12	2467	2.12	2.12	0.5
High 13	2472	2.08	2.08	0.5

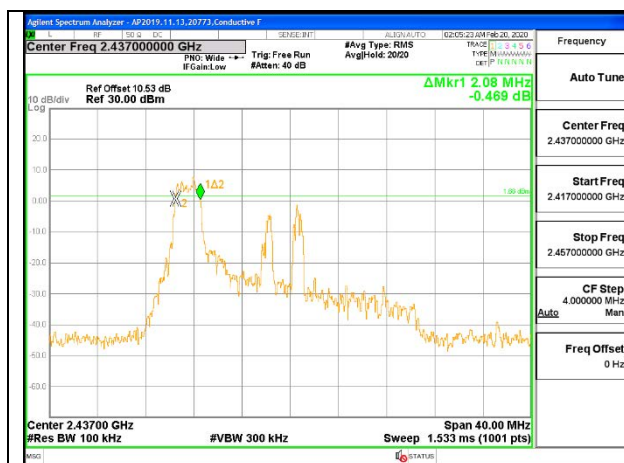

MID CHANNEL 6 ANT 4



MID CHANNEL 6 ANT 3

ANT 4 + ANT 3 2TX MODE: 26-Tones, RU Index 4

Channel	Frequency (MHz)	6dB BW(MHz) ANT 4	6dB BW (MHz) ANT 3	Minimum Limit (MHz)
Low 1	2412	2.68	2.72	0.5
Low 2	2417	2.72	2.64	0.5
Low 3	2422	2.68	2.68	0.5
Mid 6	2437	2.64	2.68	0.5
High 9	2452	2.72	2.68	0.5
High 10	2457	2.68	2.68	0.5
High 11	2462	2.68	2.68	0.5
High 12	2467	2.60	2.64	0.5
High 13	2472	2.68	2.64	0.5

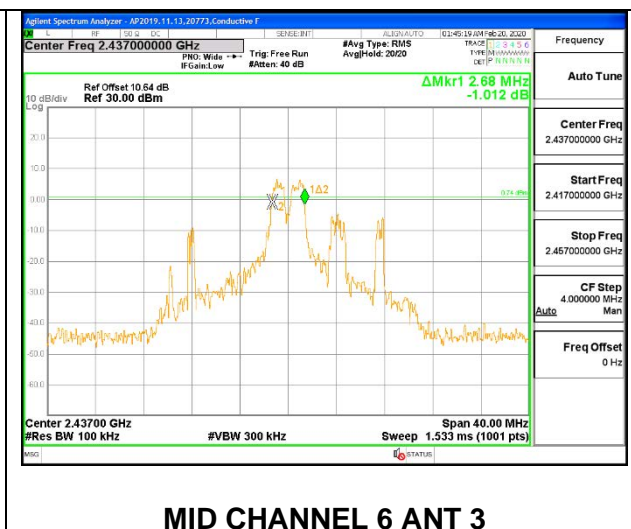
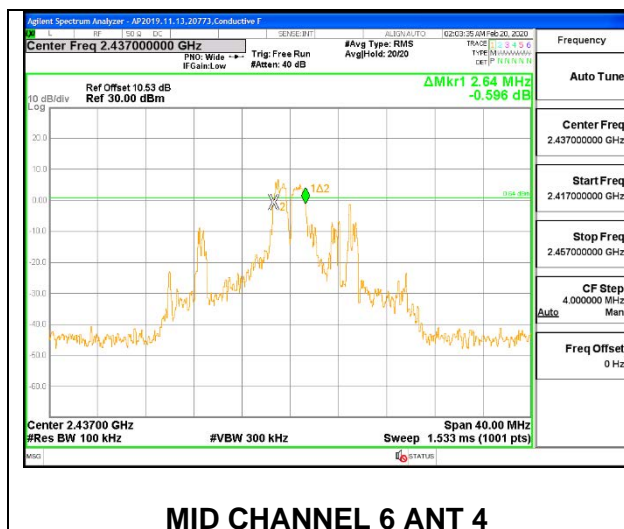

ANT 4 + ANT 3 2TX MODE: 26-Tones, RU Index 8

Channel	Frequency (MHz)	6dB BW(MHz) ANT 4	6dB BW (MHz) ANT 3	Minimum Limit (MHz)
Low 1	2412	2.08	2.08	0.5
Low 2	2417	2.08	2.08	0.5
Low 3	2422	2.16	2.16	0.5
Mid 6	2437	2.16	2.16	0.5
High 9	2452	2.08	2.08	0.5
High 10	2457	2.12	2.12	0.5
High 11	2462	2.08	2.16	0.5
High 12	2467	2.12	2.04	0.5
High 13	2472	2.08	2.16	0.5

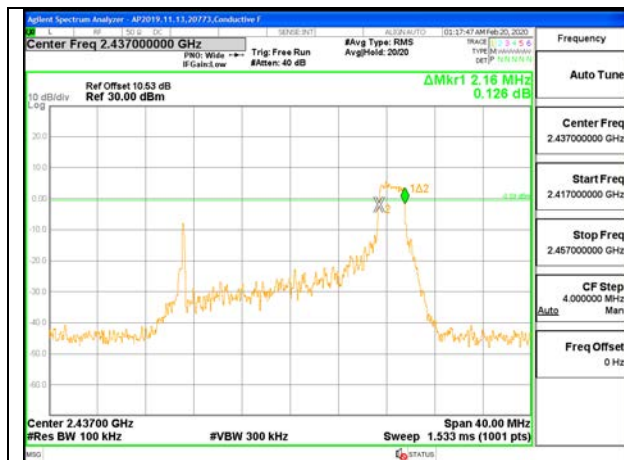

MID CHANNEL 6 ANT 4

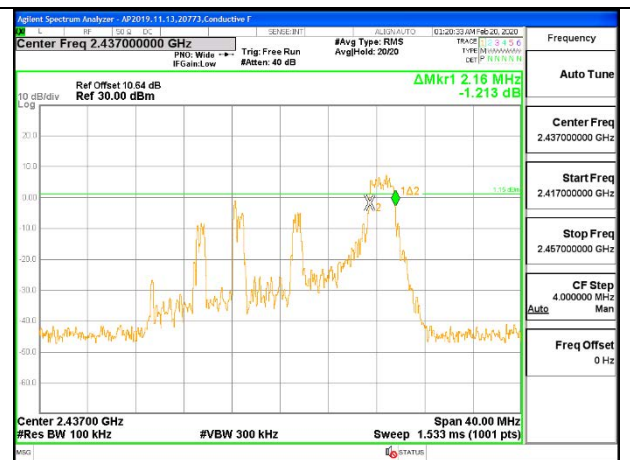

MID CHANNEL 6 ANT 3

9.4. OUTPUT POWER

LIMITS

FCC §15.247 (b) (3)

RSS-247 5.4 (d)

For systems using digital modulation in the 902–928 MHz, 2400–2483.5 MHz, and 5725–5850 MHz bands: 1 Watt, based on the use of antennas with directional gains that do not exceed 6 dBi. If transmitting antennas of directional gain greater than 6 dBi are used, the conducted output power from the intentional radiator shall be reduced by the amount in dB that the directional gain of the antenna exceeds 6 dBi.

TEST PROCEDURE

The transmitter output is connected to a power meter.

The cable assembly insertion loss of 10.5 dB (including 10 dB pad and 0.5 dB cable) was entered as an offset in the power meter to allow for average reading of power.

DIRECTIONAL ANTENNA GAIN

For 1 TX:

There is only one transmitter output therefore the directional gain is equal to the antenna gain.

For 2 TX:

Tx chains are uncorrelated for power and correlated for PSD due to the device supporting CDD in all MIMO modes. The directional gains are as follows:

Band (GHz)	ANT 4 Gain (dBi)	ANT 3 Gain (dBi)	Uncorrelated Chains Directional Gain (dBi)	Correlated Chains Directional Gain (dBi)
2.4	-2.10	-0.30	-1.11	1.86

RESULTS

9.4.1. 802.11b MODE 1TX

Test Engineer:	44353
Test Date:	7/26/2020

1TX ANT 4

Limits

Channel	Frequency (MHz)	Directional Gain (dBi)	FCC Power Limit (dBm)	ISED Power Limit (dBm)	ISED EIRP Limit (dBm)	Max Power (dBm)
Low 1	2412	-2.10	30.00	30	36	30.00
Mid 6	2437	-2.10	30.00	30	36	30.00
High 11	2462	-2.10	30.00	30	36	30.00
High 12	2467	-2.10	30.00	30	36	30.00
High 13	2472	-2.10	30.00	30	36	30.00

Duty Cycle CF (dB)	0.00	Included in Calculations of Corr'd Power
---------------------------	------	---

Results

Channel	Frequency (MHz)	Meas Power (dBm)	Total Corr'd Power (dBm)	Power Limit (dBm)	Margin (dB)
Low 1	2412	21.18	21.18	30.00	-8.82
Mid 6	2437	21.22	21.22	30.00	-8.78
High 11	2462	21.19	21.19	30.00	-8.81
High 12	2467	21.20	21.20	30.00	-8.80
High 13	2472	21.18	21.18	30.00	-8.82

*PSD is tested at higher power.

1TX ANT 3

Limits

Channel	Frequency (MHz)	Directional Gain (dBi)	FCC Power Limit (dBm)	ISED Power Limit (dBm)	ISED EIRP Limit (dBm)	Max Power (dBm)
Low 1	2412	-0.30	30.00	30	36	30.00
Mid 6	2437	-0.30	30.00	30	36	30.00
High 11	2462	-0.30	30.00	30	36	30.00
High 12	2467	-0.30	30.00	30	36	30.00
High 13	2472	-0.30	30.00	30	36	30.00

Duty Cycle CF (dB)	0.00	Included in Calculations of Corr'd Power
---------------------------	------	---

Results

Channel	Frequency (MHz)	Meas Power (dBm)	Total Corr'd Power (dBm)	Power Limit (dBm)	Margin (dB)
Low 1	2412	21.36	21.36	30.00	-8.64
Mid 6	2437	22.40	22.40	30.00	-7.60
High 11	2462	21.91	21.91	30.00	-8.09
High 12	2467	21.58	21.58	30.00	-8.42
High 13	2472	21.29	21.29	30.00	-8.71

9.4.2. 802.11n HT20 MODE

Test Engineer:	44353
Test Date:	7/26/2020

1TX ANT 4

Limits

Channel	Frequency (MHz)	Directional Gain (dBi)	FCC Power Limit (dBm)	ISED Power Limit (dBm)	ISED EIRP Limit (dBm)	Max Power (dBm)
Low 1	2412	-2.10	30.00	30	36	30.00
Low 2	2417	-2.10	30.00	30	36	30.00
Low 3	2422	-2.10	30.00	30	36	30.00
Mid 6	2437	-2.10	30.00	30	36	30.00
High 9	2452	-2.10	30.00	30	36	30.00
High 10	2457	-2.10	30.00	30	36	30.00
High 11	2462	-2.10	30.00	30	36	30.00
High 12	2467	-2.10	30.00	30	36	30.00
High 13	2472	-2.10	30.00	30	36	30.00

Duty Cycle CF (dB)	0.00	Included in Calculations of Corr'd Power
---------------------------	------	---

Results

Channel	Frequency (MHz)	Meas Power (dBm)	Total Corr'd Power (dBm)	Power Limit (dBm)	Margin (dB)
Low 1	2412	17.29	17.29	30.00	-12.71
Low 2	2417	19.42	19.42	30.00	-10.58
Low 3	2422	21.16	21.16	30.00	-8.84
Mid 6	2437	21.20	21.20	30.00	-8.80
High 9	2452	20.83	20.83	30.00	-9.17
High 10	2457	19.44	19.44	30.00	-10.56
High 11	2462	17.31	17.31	30.00	-12.69
High 12	2467	15.38	15.38	30.00	-14.62
High 13	2472	15.40	15.40	30.00	-14.60

*PSD is tested at higher power.

1TX ANT 3

Limits

Channel	Frequency (MHz)	Directional Gain (dBi)	FCC Power Limit (dBm)	ISED Power Limit (dBm)	ISED EIRP Limit (dBm)	Max Power (dBm)
Low 1	2412	-0.30	30.00	30	36	30.00
Low 2	2417	-0.30	30.00	30	36	30.00
Low 3	2422	-0.30	30.00	30	36	30.00
Mid 6	2437	-0.30	30.00	30	36	30.00
High 9	2452	-0.30	30.00	30	36	30.00
High 10	2457	-0.30	30.00	30	36	30.00
High 11	2462	-0.30	30.00	30	36	30.00
High 12	2467	-0.30	30.00	30	36	30.00
High 13	2472	-0.30	30.00	30	36	30.00

Duty Cycle CF (dB)	0.00	Included in Calculations of Corr'd Power
---------------------------	------	---

Results

Channel	Frequency (MHz)	Meas Power (dBm)	Total Corr'd Power (dBm)	Power Limit (dBm)	Margin (dB)
Low 1	2412	17.28	17.28	30.00	-12.72
Low 2	2417	19.49	19.49	30.00	-10.51
Low 3	2422	21.43	21.43	30.00	-8.57
Mid 6	2437	21.46	21.46	30.00	-8.54
High 9	2452	20.75	20.75	30.00	-9.25
High 10	2457	19.26	19.26	30.00	-10.74
High 11	2462	17.47	17.47	30.00	-12.53
High 12	2467	15.44	15.44	30.00	-14.56
High 13	2472	15.45	15.45	30.00	-14.55

9.4.3. 802.11n HT20 CDD MODE 2TX

Test Engineer:	44353
Test Date:	7/26/2020

Limits

Channel	Frequency (MHz)	Directional Gain (dBi)	FCC/ISED Power Limit (dBm)	ISED EIRP Limit (dBm)	Max Power (dBm)
Low 1	2412	-1.11	30.00	36	30.00
Low 2	2417	-1.11	30.00	36	30.00
Low 3	2422	-1.11	30.00	36	30.00
Mid 6	2437	-1.11	30.00	36	30.00
High 9	2452	-1.11	30.00	36	30.00
High 10	2457	-1.11	30.00	36	30.00
High 11	2462	-1.11	30.00	36	30.00
High 12	2467	-1.11	30.00	36	30.00
High 13	2472	-1.11	30.00	36	30.00

Duty Cycle CF (dB)	0.00	Included in Calculations of Corr'd Power
---------------------------	------	---

Results

Channel	Frequency (MHz)	ANT 4 Meas Power (dBm)	ANT 3 Meas Power (dBm)	Total Corr'd Power (dBm)	Power Limit (dBm)	Margin (dB)
Low 1	2412	16.31	16.30	19.32	30.00	-10.68
Low 2	2417	18.46	18.49	21.49	30.00	-8.51
Low 3	2422	19.91	19.96	22.95	30.00	-7.05
Mid 6	2437	21.20	21.30	24.26	30.00	-5.74
High 9	2452	19.44	19.32	22.39	30.00	-7.61
High 10	2457	18.47	18.26	21.38	30.00	-8.62
High 11	2462	16.44	16.50	19.48	30.00	-10.52
High 12	2467	13.79	13.95	16.88	30.00	-13.12
High 13	2472	14.41	14.35	17.39	30.00	-12.61

*PSD is tested at higher power.

9.4.4. 802.11ax HE20 MODE

Test Engineer:	44353
Test Date:	7/26/2020

1TX ANT 4 26-Tones, RU Index 0

Limits

Channel	Frequency (MHz)	Directional Gain (dBi)	FCC Power Limit (dBm)	ISED Power Limit (dBm)	ISED EIRP Limit (dBm)	Max Power (dBm)
Low 1	2412	-2.10	30.00	30	36	30.00
Low 2	2417	-2.10	30.00	30	36	30.00
Low 3	2422	-2.10	30.00	30	36	30.00
Mid 6	2437	-2.10	30.00	30	36	30.00
High 9	2452	-2.10	30.00	30	36	30.00
High 10	2457	-2.10	30.00	30	36	30.00
High 11	2462	-2.10	30.00	30	36	30.00
High 12	2467	-2.10	30.00	30	36	30.00
High 13	2472	-2.10	30.00	30	36	30.00

Duty Cycle CF (dB)	0.00	Included in Calculations of Corr'd Power
---------------------------	------	---

Results

Channel	Frequency (MHz)	Meas Power (dBm)	Total Corr'd Power (dBm)	Power Limit (dBm)	Margin (dB)
Low 1	2412	15.92	15.92	30.00	-14.08
Low 2	2417	17.91	17.91	30.00	-12.09
Low 3	2422	21.16	21.16	30.00	-8.84
Mid 6	2437	21.20	21.20	30.00	-8.80
High 9	2452	21.22	21.22	30.00	-8.78
High 10	2457	17.93	17.93	30.00	-12.07
High 11	2462	15.80	15.80	30.00	-14.20
High 12	2467	13.84	13.84	30.00	-16.16
High 13	2472	-0.13	-0.13	30.00	-30.13

*PSD is tested at higher power.

1TX ANT 4 26-Tones, RU Index 4

Limits

Channel	Frequency (MHz)	Directional Gain (dBi)	FCC Power Limit (dBm)	ISED Power Limit (dBm)	ISED EIRP Limit (dBm)	Max Power (dBm)
Low 1	2412	-2.10	30.00	30	36	30.00
Low 2	2417	-2.10	30.00	30	36	30.00
Low 3	2422	-2.10	30.00	30	36	30.00
Mid 6	2437	-2.10	30.00	30	36	30.00
High 9	2452	-2.10	30.00	30	36	30.00
High 10	2457	-2.10	30.00	30	36	30.00
High 11	2462	-2.10	30.00	30	36	30.00
High 12	2467	-2.10	30.00	30	36	30.00
High 13	2472	-2.10	30.00	30	36	30.00

Duty Cycle CF (dB)	0.00	Included in Calculations of Corr'd Power
---------------------------	------	---

Results

Channel	Frequency (MHz)	Meas Power (dBm)	Total Corr'd Power (dBm)	Power Limit (dBm)	Margin (dB)
Low 1	2412	15.93	15.93	30.00	-14.07
Low 2	2417	17.89	17.89	30.00	-12.11
Low 3	2422	21.15	21.15	30.00	-8.85
Mid 6	2437	21.18	21.18	30.00	-8.82
High 9	2452	21.20	21.20	30.00	-8.80
High 10	2457	17.93	17.93	30.00	-12.07
High 11	2462	15.81	15.81	30.00	-14.19
High 12	2467	13.78	13.78	30.00	-16.22
High 13	2472	-0.09	-0.09	30.00	-30.09

*PSD is tested at higher power.

1TX ANT 4 26-Tones, RU Index 8

Limits

Channel	Frequency (MHz)	Directional Gain (dBi)	FCC Power Limit (dBm)	ISED Power Limit (dBm)	ISED EIRP Limit (dBm)	Max Power (dBm)
Low 1	2412	-2.10	30.00	30	36	30.00
Low 2	2417	-2.10	30.00	30	36	30.00
Low 3	2422	-2.10	30.00	30	36	30.00
Mid 6	2437	-2.10	30.00	30	36	30.00
High 9	2452	-2.10	30.00	30	36	30.00
High 10	2457	-2.10	30.00	30	36	30.00
High 11	2462	-2.10	30.00	30	36	30.00
High 12	2467	-2.10	30.00	30	36	30.00
High 13	2472	-2.10	30.00	30	36	30.00

Duty Cycle CF (dB)	0.00	Included in Calculations of Corr'd Power
---------------------------	------	---

Results

Channel	Frequency (MHz)	Meas Power (dBm)	Total Corr'd Power (dBm)	Power Limit (dBm)	Margin (dB)
Low 1	2412	15.96	15.96	30.00	-14.04
Low 2	2417	17.90	17.90	30.00	-12.10
Low 3	2422	21.15	21.15	30.00	-8.85
Mid 6	2437	21.18	21.18	30.00	-8.82
High 9	2452	21.17	21.17	30.00	-8.83
High 10	2457	17.79	17.79	30.00	-12.21
High 11	2462	15.82	15.82	30.00	-14.18
High 12	2467	13.99	13.99	30.00	-16.01
High 13	2472	-0.14	-0.14	30.00	-30.14

*PSD is tested at higher power.

1TX ANT 4 242-Tones, RU Index 61

Limits

Channel	Frequency (MHz)	Directional Gain (dBi)	FCC Power Limit (dBm)	ISED Power Limit (dBm)	ISED EIRP Limit (dBm)	Max Power (dBm)
Low 1	2412	-2.10	30.00	30	36	30.00
Low 2	2417	-2.10	30.00	30	36	30.00
Low 3	2422	-2.10	30.00	30	36	30.00
Mid 6	2437	-2.10	30.00	30	36	30.00
High 9	2452	-2.10	30.00	30	36	30.00
High 10	2457	-2.10	30.00	30	36	30.00
High 11	2462	-2.10	30.00	30	36	30.00
High 12	2467	-2.10	30.00	30	36	30.00
High 13	2472	-2.10	30.00	30	36	30.00

Duty Cycle CF (dB)	0.00	Included in Calculations of Corr'd Power
---------------------------	------	---

Results

Channel	Frequency (MHz)	Meas Power (dBm)	Total Corr'd Power (dBm)	Power Limit (dBm)	Margin (dB)
Low 1	2412	15.81	15.81	30.00	-14.19
Low 2	2417	17.94	17.94	30.00	-12.06
Low 3	2422	21.15	21.15	30.00	-8.85
Mid 6	2437	21.20	21.20	30.00	-8.80
High 9	2452	21.16	21.16	30.00	-8.84
High 10	2457	17.91	17.91	30.00	-12.09
High 11	2462	15.76	15.76	30.00	-14.24
High 12	2467	13.92	13.92	30.00	-16.08
High 13	2472	10.87	10.87	30.00	-19.13

*PSD is tested at higher power.

1TX ANT 3 26-Tones, RU Index 0

Limits

Channel	Frequency (MHz)	Directional Gain (dBi)	FCC Power Limit (dBm)	ISED Power Limit (dBm)	ISED EIRP Limit (dBm)	Max Power (dBm)
Low 1	2412	-0.30	30.00	30	36	30.00
Low 2	2417	-0.30	30.00	30	36	30.00
Low 3	2422	-0.30	30.00	30	36	30.00
Mid 6	2437	-0.30	30.00	30	36	30.00
High 9	2452	-0.30	30.00	30	36	30.00
High 10	2457	-0.30	30.00	30	36	30.00
High 11	2462	-0.30	30.00	30	36	30.00
High 12	2467	-0.30	30.00	30	36	30.00
High 13	2472	-0.30	30.00	30	36	30.00

Duty Cycle CF (dB)	0.00	Included in Calculations of Corr'd Power
---------------------------	------	---

Results

Channel	Frequency (MHz)	Meas Power (dBm)	Total Corr'd Power (dBm)	Power Limit (dBm)	Margin (dB)
Low 1	2412	15.91	15.91	30.00	-14.09
Low 2	2417	17.95	17.95	30.00	-12.05
Low 3	2422	21.44	21.44	30.00	-8.56
Mid 6	2437	21.46	21.46	30.00	-8.54
High 9	2452	21.42	21.42	30.00	-8.58
High 10	2457	17.82	17.82	30.00	-12.18
High 11	2462	15.84	15.84	30.00	-14.16
High 12	2467	13.90	13.90	30.00	-16.10
High 13	2472	-0.10	-0.10	30.00	-30.10

1TX ANT 3 26-Tones, RU Index 4

Limits

Channel	Frequency (MHz)	Directional Gain (dBi)	FCC Power Limit (dBm)	ISED Power Limit (dBm)	ISED EIRP Limit (dBm)	Max Power (dBm)
Low 1	2412	-0.30	30.00	30	36	30.00
Low 2	2417	-0.30	30.00	30	36	30.00
Low 3	2422	-0.30	30.00	30	36	30.00
Mid 6	2437	-0.30	30.00	30	36	30.00
High 9	2452	-0.30	30.00	30	36	30.00
High 10	2457	-0.30	30.00	30	36	30.00
High 11	2462	-0.30	30.00	30	36	30.00
High 12	2467	-0.30	30.00	30	36	30.00
High 13	2472	-0.30	30.00	30	36	30.00

Duty Cycle CF (dB)	0.00	Included in Calculations of Corr'd Power
---------------------------	------	---

Results

Channel	Frequency (MHz)	Meas Power (dBm)	Total Corr'd Power (dBm)	Power Limit (dBm)	Margin (dB)
Low 1	2412	15.93	15.93	30.00	-14.07
Low 2	2417	17.95	17.95	30.00	-12.05
Low 3	2422	21.43	21.43	30.00	-8.57
Mid 6	2437	21.48	21.48	30.00	-8.52
High 9	2452	21.44	21.44	30.00	-8.56
High 10	2457	17.80	17.80	30.00	-12.20
High 11	2462	15.91	15.91	30.00	-14.09
High 12	2467	13.96	13.96	30.00	-16.04
High 13	2472	-0.02	-0.02	30.00	-30.02

1TX ANT 3 26-Tones, RU Index 8

Limits

Channel	Frequency (MHz)	Directional Gain (dBi)	FCC Power Limit (dBm)	ISED Power Limit (dBm)	ISED EIRP Limit (dBm)	Max Power (dBm)
Low 1	2412	-0.30	30.00	30	36	30.00
Low 2	2417	-0.30	30.00	30	36	30.00
Low 3	2422	-0.30	30.00	30	36	30.00
Mid 6	2437	-0.30	30.00	30	36	30.00
High 9	2452	-0.30	30.00	30	36	30.00
High 10	2457	-0.30	30.00	30	36	30.00
High 11	2462	-0.30	30.00	30	36	30.00
High 12	2467	-0.30	30.00	30	36	30.00
High 13	2472	-0.30	30.00	30	36	30.00

Duty Cycle CF (dB)	0.00	Included in Calculations of Corr'd Power
---------------------------	------	---

Results

Channel	Frequency (MHz)	Meas Power (dBm)	Total Corr'd Power (dBm)	Power Limit (dBm)	Margin (dB)
Low 1	2412	15.88	15.88	30.00	-14.12
Low 2	2417	17.83	17.83	30.00	-12.17
Low 3	2422	21.45	21.45	30.00	-8.55
Mid 6	2437	21.45	21.45	30.00	-8.55
High 9	2452	21.43	21.43	30.00	-8.57
High 10	2457	17.78	17.78	30.00	-12.22
High 11	2462	15.92	15.92	30.00	-14.08
High 12	2467	13.92	13.92	30.00	-16.08
High 13	2472	-0.11	-0.11	30.00	-30.11

1TX ANT 3 242-Tones, RU Index 61

Limits

Channel	Frequency (MHz)	Directional Gain (dBi)	FCC Power Limit (dBm)	ISED Power Limit (dBm)	ISED EIRP Limit (dBm)	Max Power (dBm)
Low 1	2412	-0.30	30.00	30	36	30.00
Low 2	2417	-0.30	30.00	30	36	30.00
Low 3	2422	-0.30	30.00	30	36	30.00
Mid 6	2437	-0.30	30.00	30	36	30.00
High 9	2452	-0.30	30.00	30	36	30.00
High 10	2457	-0.30	30.00	30	36	30.00
High 11	2462	-0.30	30.00	30	36	30.00
High 12	2467	-0.30	30.00	30	36	30.00
High 13	2472	-0.30	30.00	30	36	30.00

Duty Cycle CF (dB)	0.00	Included in Calculations of Corr'd Power
---------------------------	------	---

Results

Channel	Frequency (MHz)	Meas Power (dBm)	Total Corr'd Power (dBm)	Power Limit (dBm)	Margin (dB)
Low 1	2412	15.93	15.93	30.00	-14.07
Low 2	2417	17.92	17.92	30.00	-12.08
Low 3	2422	21.41	21.41	30.00	-8.59
Mid 6	2437	21.44	21.44	30.00	-8.56
High 9	2452	21.39	21.39	30.00	-8.61
High 10	2457	17.90	17.90	30.00	-12.10
High 11	2462	15.87	15.87	30.00	-14.13
High 12	2467	13.86	13.86	30.00	-16.14
High 13	2472	10.81	10.81	30.00	-19.19

9.4.5. 802.11ax HE20 OFDMA MODE 2TX

Test Engineer:	44353
Test Date:	7/26/2020

ANT 4 + ANT 3 2TX 26-Tones, RU Index 0

Limits

Channel	Frequency (MHz)	Directional Gain (dBi)	FCC/ISED Power Limit (dBm)	ISED EIRP Limit (dBm)	Max Power (dBm)
Low 1	2412	-1.11	30.00	36	30.00
Low 2	2417	-1.11	30.00	36	30.00
Low 3	2422	-1.11	30.00	36	30.00
Mid 6	2437	-1.11	30.00	36	30.00
High 9	2452	-1.11	30.00	36	30.00
High 10	2457	-1.11	30.00	36	30.00
High 11	2462	-1.11	30.00	36	30.00
High 12	2467	-1.11	30.00	36	30.00
High 13	2472	-1.11	30.00	36	30.00

Duty Cycle CF (dB)	0.00	Included in Calculations of Corr'd Power
---------------------------	------	---

Results

Channel	Frequency (MHz)	ANT 4 Meas Power (dBm)	ANT 3 Meas Power (dBm)	Total Corr'd Power (dBm)	Power Limit (dBm)	Margin (dB)
Low 1	2412	14.90	14.94	17.93	30.00	-12.07
Low 2	2417	16.84	16.85	19.86	30.00	-10.14
Low 3	2422	18.79	18.96	21.89	30.00	-8.11
Mid 6	2437	19.78	19.84	22.82	30.00	-7.18
High 9	2452	18.44	18.42	21.44	30.00	-8.56
High 10	2457	16.94	16.89	19.93	30.00	-10.07
High 11	2462	14.80	14.83	17.83	30.00	-12.17
High 12	2467	12.92	12.88	15.91	30.00	-14.09
High 13	2472	-0.02	-0.10	2.95	30.00	-27.05

ANT 4 + ANT 3, 2TX 26-Tones, RU Index 4

Limits

Channel	Frequency (MHz)	Directional Gain (dBi)	FCC/ISED Power Limit (dBm)	ISED EIRP Limit (dBm)	Max Power (dBm)
Low 1	2412	-1.11	30.00	36	30.00
Low 2	2417	-1.11	30.00	36	30.00
Low 3	2422	-1.11	30.00	36	30.00
Mid 6	2437	-1.11	30.00	36	30.00
High 9	2452	-1.11	30.00	36	30.00
High 10	2457	-1.11	30.00	36	30.00
High 11	2462	-1.11	30.00	36	30.00
High 12	2467	-1.11	30.00	36	30.00
High 13	2472	-1.11	30.00	36	30.00

Duty Cycle CF (dB)	0.00	Included in Calculations of Corr'd Power
---------------------------	------	---

Results

Channel	Frequency (MHz)	ANT 4 Meas Power (dBm)	ANT 3 Meas Power (dBm)	Total Corr'd Power (dBm)	Power Limit (dBm)	Margin (dB)
Low 1	2412	14.89	14.96	17.94	30.00	-12.06
Low 2	2417	16.94	16.90	19.93	30.00	-10.07
Low 3	2422	18.97	18.80	21.90	30.00	-8.10
Mid 6	2437	19.82	19.88	22.86	30.00	-7.14
High 9	2452	18.41	18.40	21.42	30.00	-8.58
High 10	2457	16.95	16.91	19.94	30.00	-10.06
High 11	2462	14.84	14.93	17.90	30.00	-12.10
High 12	2467	12.92	12.90	15.92	30.00	-14.08
High 13	2472	-0.22	-0.14	2.83	30.00	-27.17

ANT 4 + ANT 3, 2TX 26-Tones, RU Index 8

Limits

Channel	Frequency (MHz)	Directional Gain (dBi)	FCC/ISED Power Limit (dBm)	ISED EIRP Limit (dBm)	Max Power (dBm)
Low 1	2412	-1.11	30.00	36	30.00
Low 2	2417	-1.11	30.00	36	30.00
Low 3	2422	-1.11	30.00	36	30.00
Mid 6	2437	-1.11	30.00	36	30.00
High 9	2452	-1.11	30.00	36	30.00
High 10	2457	-1.11	30.00	36	30.00
High 11	2462	-1.11	30.00	36	30.00
High 12	2467	-1.11	30.00	36	30.00
High 13	2472	-1.11	30.00	36	30.00

Duty Cycle CF (dB)	0.00	Included in Calculations of Corr'd Power
---------------------------	------	---

Results

Channel	Frequency (MHz)	ANT 4 Meas Power (dBm)	ANT 3 Meas Power (dBm)	Total Corr'd Power (dBm)	Power Limit (dBm)	Margin (dB)
Low 1	2412	14.93	14.91	17.93	30.00	-12.07
Low 2	2417	16.93	16.87	19.91	30.00	-10.09
Low 3	2422	18.90	18.79	21.86	30.00	-8.14
Mid 6	2437	19.81	19.88	22.86	30.00	-7.14
High 9	2452	18.41	18.38	21.41	30.00	-8.59
High 10	2457	16.91	16.89	19.91	30.00	-10.09
High 11	2462	14.80	14.86	17.84	30.00	-12.16
High 12	2467	12.94	12.91	15.94	30.00	-14.06
High 13	2472	-0.05	-0.02	2.98	30.00	-27.02

ANT 4 + ANT 3, 2TX 242-Tones, RU Index 61

Limits

Channel	Frequency (MHz)	Directional Gain (dBi)	FCC/ISED Power Limit (dBm)	ISED EIRP Limit (dBm)	Max Power (dBm)
Low 1	2412	-1.11	30.00	36	30.00
Low 2	2417	-1.11	30.00	36	30.00
Low 3	2422	-1.11	30.00	36	30.00
Low 4	2427	-1.11	30.00	36	30.00
Mid 6	2437	-1.11	30.00	36	30.00
High 8	2447	-1.11	30.00	36	30.00
High 9	2452	-1.11	30.00	36	30.00
High 10	2457	-1.11	30.00	36	30.00
High 11	2462	-1.11	30.00	36	30.00
High 12	2467	-1.11	30.00	36	30.00
High 13	2472	-1.11	30.00	36	30.00

Duty Cycle CF (dB)	0.00	Included in Calculations of Corr'd Power
---------------------------	------	---

Results

Channel	Frequency (MHz)	ANT 4 Meas Power (dBm)	ANT 3 Meas Power (dBm)	Total Corr'd Power (dBm)	Power Limit (dBm)	Margin (dB)
Low 1	2412	14.79	14.95	17.88	30.00	-12.12
Low 2	2417	16.77	16.80	19.80	30.00	-10.20
Low 3	2422	18.76	18.84	21.81	30.00	-8.19
Low 4	2427	21.15	21.47	24.32	30.00	-5.68
Mid 6	2437	21.16	21.38	24.28	30.00	-5.72
High 8	2447	21.18	21.39	24.30	30.00	-5.70
High 9	2452	18.25	18.49	21.38	30.00	-8.62
High 10	2457	16.96	16.94	19.96	30.00	-10.04
High 11	2462	14.76	14.93	17.86	30.00	-12.14
High 12	2467	12.87	12.91	15.90	30.00	-14.10
High 13	2472	8.41	8.44	11.44	30.00	-18.56

*PSD of UAT is tested at higher power.

9.5. POWER SPECTRAL DENSITY

LIMITS

FCC §15.247 (e)

RSS-247 (5.2) (b)

The power spectral density conducted from the transmitter to the antenna shall not be greater than 8 dBm in any 3 kHz band during any time interval of continuous transmission.

RESULTS

Only Mid channel plot is reported to show setting parameter complies with testing method/procedure.

Note: RBW setting is used greater than 3KHz on PSD measurement

9.5.1. 802.11b MODE 1TX

1TX ANT 4

Duty Cycle CF (dB)		0.00	Included in Calculations of Corr'd PSD		
Channel	Frequency (MHz)	Meas (dBm)	Total Corr'd PSD (dBm)	Limit (dBm/ 3kHz)	Margin (dB)
Low 1	2412	-0.89	-0.89	8.0	-8.9
Mid 6	2437	-0.03	-0.03	8.0	-8.0
High 11	2462	-0.03	-0.03	8.0	-8.0
High 12	2467	-1.01	-1.01	8.0	-9.0
High 13	2472	-0.38	-0.38	8.0	-8.4

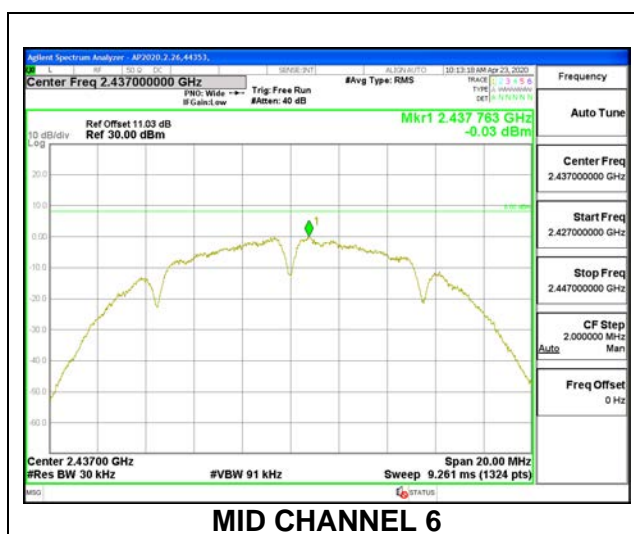

1TX ANT 3

Duty Cycle CF (dB)		0.00	Included in Calculations of Corr'd PSD		
Channel	Frequency (MHz)	Meas (dBm)	Total Corr'd PSD (dBm)	Limit (dBm/ 3kHz)	Margin (dB)
Low 1	2412	-0.99	-0.99	8.0	-9.0
Mid 6	2437	-0.06	-0.06	8.0	-8.1
High 11	2462	0.08	0.08	8.0	-7.9
High 12	2467	-0.91	-0.91	8.0	-8.9
High 13	2472	-0.32	-0.32	8.0	-8.3

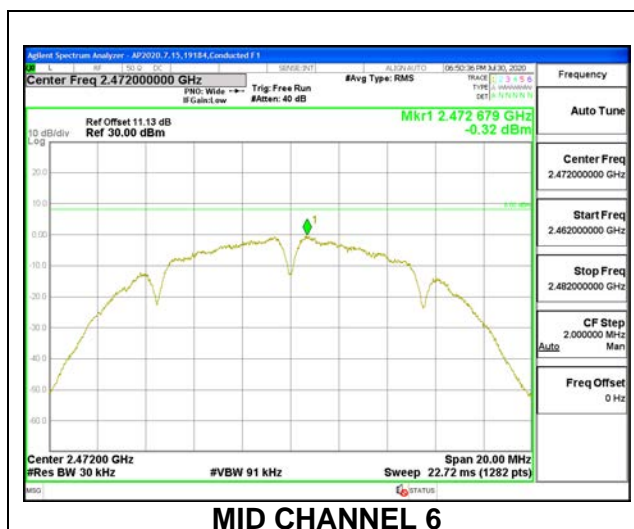

9.5.2. 802.11n HT20 MODE

1TX ANT 4

Duty Cycle CF (dB)		0.00	Included in Calculations of Corr'd PSD		
Channel	Frequency (MHz)	Meas (dBm)	Total Corr'd PSD (dBm)	Limit (dBm/ 3kHz)	Margin (dB)
Low 1	2412	-6.90	-6.90	8.0	-14.9
Low 2	2417	-4.61	-4.61	8.0	-12.6
Low 3	2422	-2.62	-2.62	8.0	-10.6
Mid 6	2437	-2.14	-2.14	8.0	-10.1
High 9	2452	-2.11	-2.11	8.0	-10.1
High 10	2457	-4.47	-4.47	8.0	-12.5
High 11	2462	-6.78	-6.78	8.0	-14.8
High 12	2467	-8.53	-8.53	8.0	-16.5
High 13	2472	-6.62	-6.62	8.0	-14.6

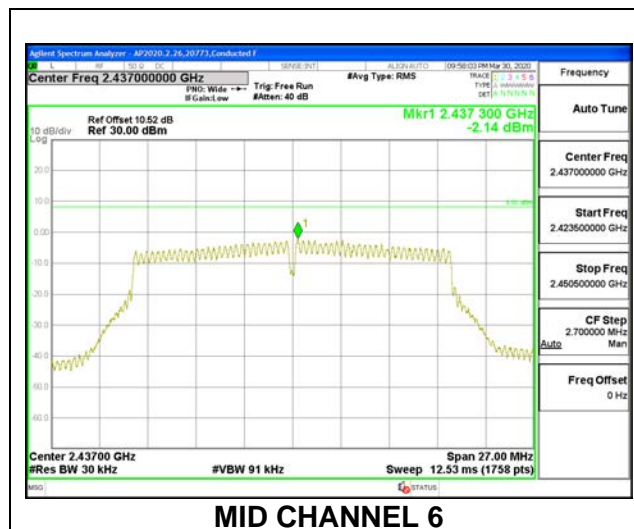

1TX ANT 3

Duty Cycle CF (dB)		0.00	Included in Calculations of Corr'd PSD		
Channel	Frequency (MHz)	Meas (dBm)	Total Corr'd PSD (dBm)	Limit (dBm/ 3kHz)	Margin (dB)
Low 1	2412	-7.12	-7.12	8.0	-15.1
Low 2	2417	-4.49	-4.49	8.0	-12.5
Low 3	2422	-2.52	-2.52	8.0	-10.5
Mid 6	2437	-2.46	-2.46	8.0	-10.5
High 9	2452	-2.48	-2.48	8.0	-10.5
High 10	2457	-4.96	-4.96	8.0	-13.0
High 11	2462	-6.45	-6.45	8.0	-14.5
High 12	2467	-8.57	-8.57	8.0	-16.6
High 13	2472	-6.87	-6.87	8.0	-14.9

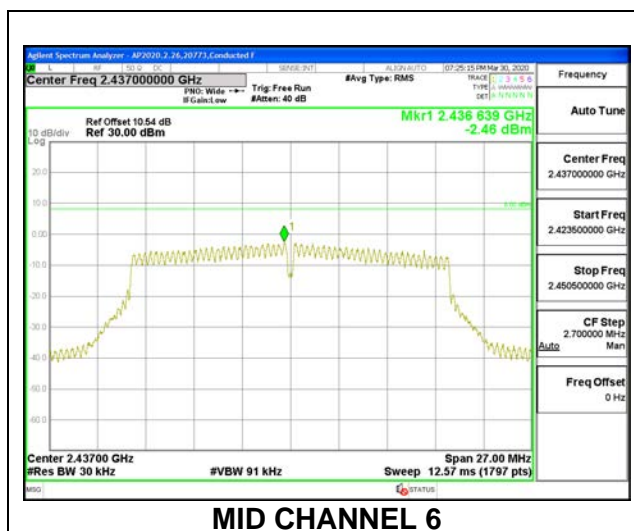

9.5.3. 802.11n HT20 CDD MODE 2TX

Duty Cycle CF (dB)		0.00		Included in Calculations of Corr'd PSD		
Channel	Frequency (MHz)	ANT 4 Meas (dBm)	ANT 3 Meas (dBm)	Total Corr'd PSD (dBm)	Limit (dBm/ 3kHz)	Margin (dB)
Low 1	2412	-8.01	-8.13	-5.06	8.0	-13.1
Low 2	2417	-5.48	-5.53	-2.49	8.0	-10.5
Low 3	2422	-4.00	-3.88	-0.93	8.0	-8.9
Mid 6	2437	-2.62	-2.36	0.52	8.0	-7.5
High 9	2452	-4.36	-4.73	-1.53	8.0	-9.5
High 10	2457	-5.44	-6.17	-2.78	8.0	-10.8
High 11	2462	-7.70	-7.57	-4.62	8.0	-12.6
High 12	2467	-10.35	-9.73	-7.02	8.0	-15.0
High 13	2472	-7.36	-7.26	-4.30	8.0	-12.3

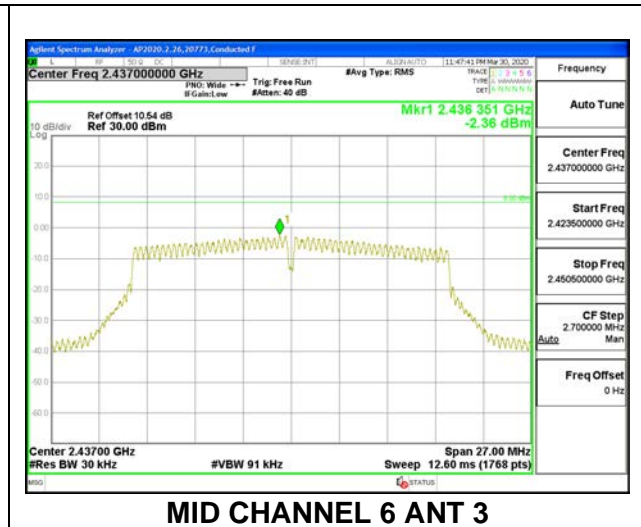
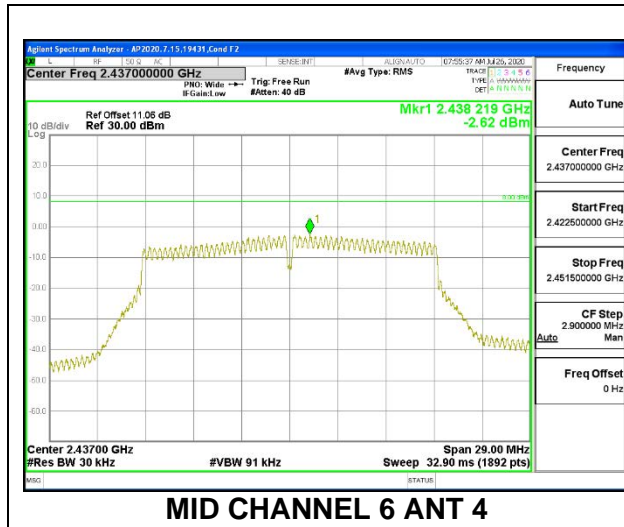

9.5.4. 802.11ax HE20 MODE

1TX ANT 4 , 26-Tone RU Index 0

Duty Cycle CF (dB)		0.00	Included in Calculations of Corr'd PSD		
Channel	Frequency (MHz)	Meas (dBm)	Total Corr'd PSD (dBm)	Limit (dBm/ 3kHz)	Margin (dB)
Low 1	2412	-1.07	-1.07	8.0	-9.1
Low 2	2417	0.99	0.99	8.0	-7.0
Low 3	2422	4.23	4.23	8.0	-3.8
Mid 6	2437	4.24	4.24	8.0	-3.8
High 9	2452	4.23	4.23	8.0	-3.8
High 10	2457	1.01	1.01	8.0	-7.0
High 11	2462	-1.34	-1.34	8.0	-9.3
High 12	2467	-3.20	-3.20	8.0	-11.2
High 13	2472	-9.49	-9.49	8.0	-17.5

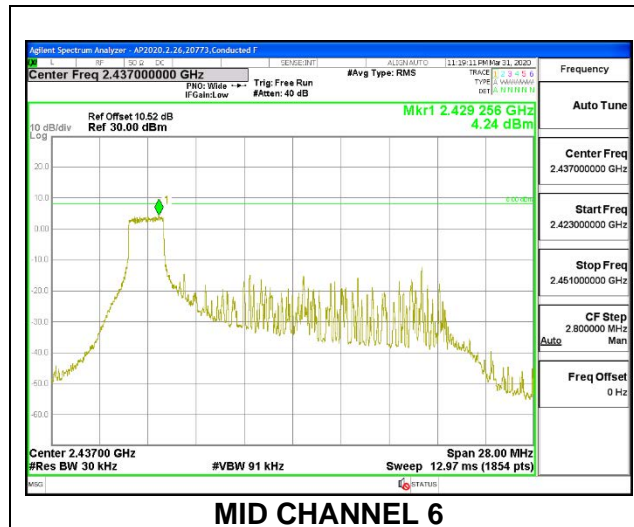

1TX ANT 4 , 26-Tone RU Index 4

Duty Cycle CF (dB)		0.00	Included in Calculations of Corr'd PSD		
Channel	Frequency (MHz)	Meas (dBm)	Total Corr'd PSD (dBm)	Limit (dBm/ 3kHz)	Margin (dB)
Low 1	2412	-1.00	-1.00	8.0	-9.0
Low 2	2417	0.94	0.94	8.0	-7.1
Low 3	2422	4.22	4.22	8.0	-3.8
Mid 6	2437	4.22	4.22	8.0	-3.8
High 9	2452	4.20	4.20	8.0	-3.8
High 10	2457	1.04	1.04	8.0	-7.0
High 11	2462	-1.29	-1.29	8.0	-9.3
High 12	2467	-3.19	-3.19	8.0	-11.2
High 13	2472	-9.58	-9.58	8.0	-17.6

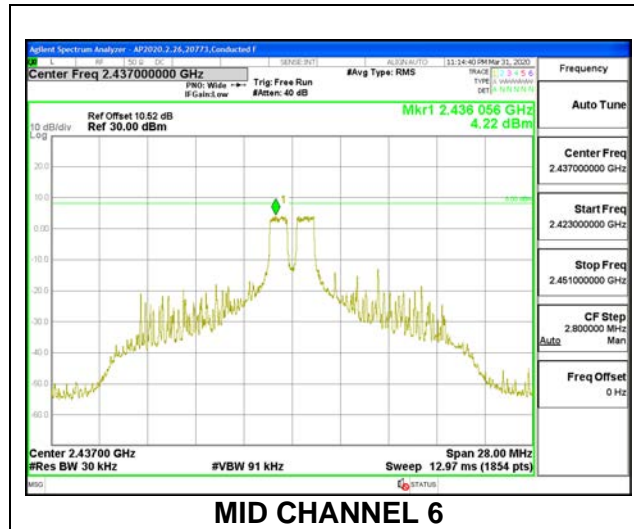

MID CHANNEL 6

1TX ANT 4 , 26-Tone RU Index 8

Duty Cycle CF (dB)		0.00	Included in Calculations of Corr'd PSD		
Channel	Frequency (MHz)	Meas (dBm)	Total Corr'd PSD (dBm)	Limit (dBm/ 3kHz)	Margin (dB)
Low 1	2412	-0.89	-0.89	8.0	-8.9
Low 2	2417	0.96	0.96	8.0	-7.0
Low 3	2422	4.57	4.57	8.0	-3.4
Mid 6	2437	4.65	4.65	8.0	-3.4
High 9	2452	4.59	4.59	8.0	-3.4
High 10	2457	0.81	0.81	8.0	-7.2
High 11	2462	-1.55	-1.55	8.0	-9.6
High 12	2467	-3.10	-3.10	8.0	-11.1
High 13	2472	-9.15	-9.15	8.0	-17.2

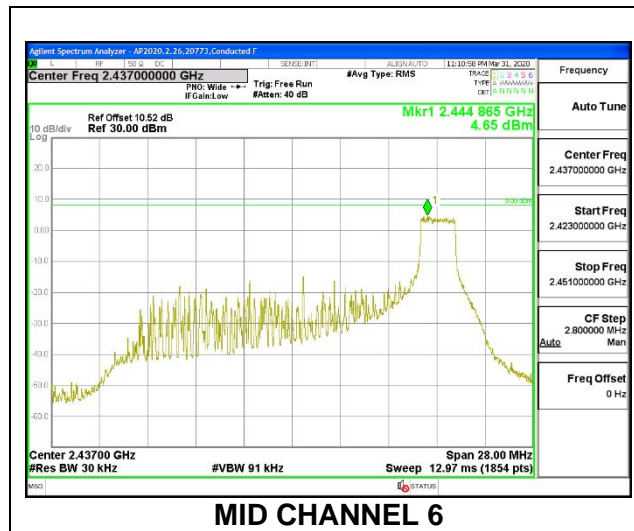

1TX ANT 4 , 242-Tone RU Index 61

Duty Cycle CF (dB)		0.00	Included in Calculations of Corr'd PSD		
Channel	Frequency (MHz)	Meas (dBm)	Total Corr'd PSD (dBm)	Limit (dBm/ 3kHz)	Margin (dB)
Low 1	2412	-8.81	-8.81	8.0	-16.8
Low 2	2417	-7.30	-7.30	8.0	-15.3
Low 3	2422	-4.02	-4.02	8.0	-12.0
Mid 6	2437	-4.04	-4.04	8.0	-12.0
High 9	2452	-4.14	-4.14	8.0	-12.1
High 10	2457	-7.40	-7.40	8.0	-15.4
High 11	2462	-9.41	-9.41	8.0	-17.4
High 12	2467	-11.68	-11.68	8.0	-19.7
High 13	2472	-13.78	-13.78	8.0	-21.8

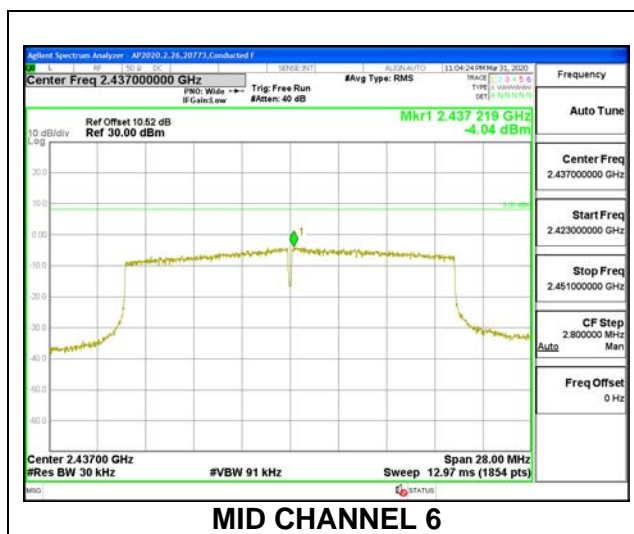

1TX ANT 3 , 26-Tone RU Index 0

Duty Cycle CF (dB)		0.00	Included in Calculations of Corr'd PSD		
Channel	Frequency (MHz)	Meas (dBm)	Total Corr'd PSD (dBm)	Limit (dBm/ 3kHz)	Margin (dB)
Low 1	2412	-1.03	-1.03	8.0	-9.0
Low 2	2417	0.96	0.96	8.0	-7.0
Low 3	2422	4.08	4.08	8.0	-3.9
Mid 6	2437	4.11	4.11	8.0	-3.9
High 9	2452	4.10	4.10	8.0	-3.9
High 10	2457	0.70	0.70	8.0	-7.3
High 11	2462	-1.21	-1.21	8.0	-9.2
High 12	2467	-3.26	-3.26	8.0	-11.3
High 13	2472	-17.17	-17.17	8.0	-25.2

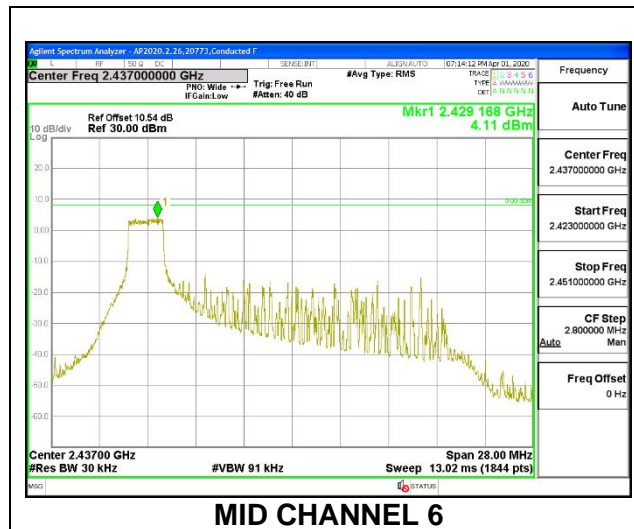

MID CHANNEL 6

1TX ANT 3 , 26-Tone RU Index 4

Duty Cycle CF (dB)		0.00	Included in Calculations of Corr'd PSD		
Channel	Frequency (MHz)	Meas (dBm)	Total Corr'd PSD (dBm)	Limit (dBm/ 3kHz)	Margin (dB)
Low 1	2412	-0.97	-0.97	8.0	-9.0
Low 2	2417	1.00	1.00	8.0	-7.0
Low 3	2422	4.10	4.10	8.0	-3.9
Mid 6	2437	4.17	4.17	8.0	-3.8
High 9	2452	4.14	4.14	8.0	-3.9
High 10	2457	0.79	0.79	8.0	-7.2
High 11	2462	-1.03	-1.03	8.0	-9.0
High 12	2467	-3.15	-3.15	8.0	-11.2
High 13	2472	-15.61	-15.61	8.0	-23.6

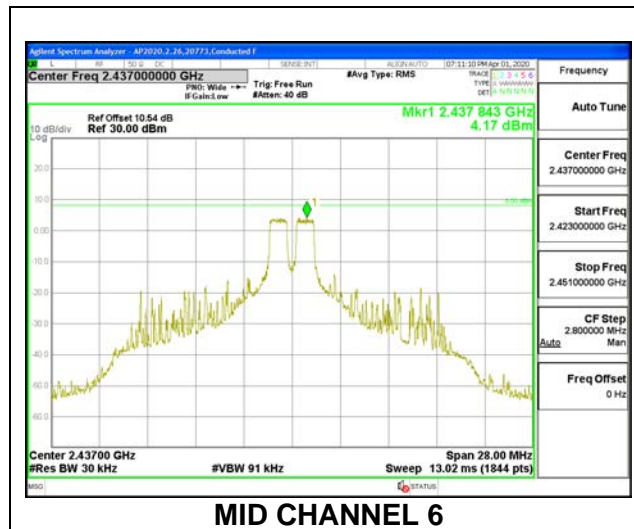

1TX ANT 3 , 26-Tone RU Index 8

Duty Cycle CF (dB)		0.00	Included in Calculations of Corr'd PSD		
Channel	Frequency (MHz)	Meas (dBm)	Total Corr'd PSD (dBm)	Limit (dBm/ 3kHz)	Margin (dB)
Low 1	2412	-1.26	-1.26	8.0	-9.3
Low 2	2417	0.81	0.81	8.0	-7.2
Low 3	2422	4.21	4.21	8.0	-3.8
Mid 6	2437	4.23	4.23	8.0	-3.8
High 9	2452	4.22	4.22	8.0	-3.8
High 10	2457	0.72	0.72	8.0	-7.3
High 11	2462	-1.17	-1.17	8.0	-9.2
High 12	2467	-3.23	-3.23	8.0	-11.2
High 13	2472	-17.16	-17.16	8.0	-25.2

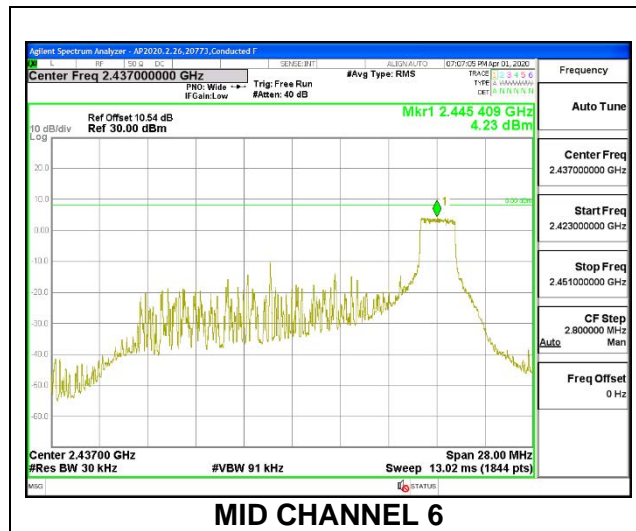

1TX ANT 3 , 242-Tone RU Index 61

Duty Cycle CF (dB)		0.00	Included in Calculations of Corr'd PSD		
Channel	Frequency (MHz)	Meas (dBm)	Total Corr'd PSD (dBm)	Limit (dBm/ 3kHz)	Margin (dB)
Low 1	2412	-8.90	-8.90	8.0	-16.9
Low 2	2417	-7.61	-7.61	8.0	-15.6
Low 3	2422	-3.62	-3.62	8.0	-11.6
Mid 6	2437	-3.57	-3.57	8.0	-11.6
High 9	2452	-3.65	-3.65	8.0	-11.6
High 10	2457	-7.68	-7.68	8.0	-15.7
High 11	2462	-9.38	-9.38	8.0	-17.4
High 12	2467	-10.73	-10.73	8.0	-18.7
High 13	2472	-18.14	-18.14	8.0	-26.1

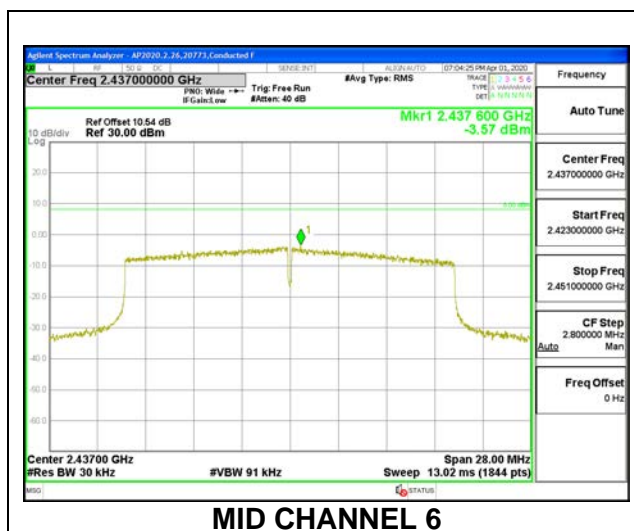

9.5.5. 802.11ax HE20 OFDMA MODE 2TX

ANT 4 + ANT 3, 2TX, 26-Tones, RU Index 0

Duty Cycle CF (dB)		0.00		Included in Calculations of Corr'd PSD		
Channel	Frequency (MHz)	ANT 4 Meas (dBm)	ANT 3 Meas (dBm)	Total Corr'd PSD (dBm)	Limit (dBm/ 3kHz)	Margin (dB)
Low 1	2412	-2.16	-1.93	0.97	8.0	-7.0
Low 2	2417	-0.59	-0.54	2.45	8.0	-5.6
Low 3	2422	1.72	2.12	4.93	8.0	-3.1
Mid 6	2437	2.95	3.07	6.02	8.0	-2.0
High 9	2452	1.55	1.54	4.56	8.0	-3.4
High 10	2457	-0.37	-0.51	2.57	8.0	-5.4
High 11	2462	-2.41	-2.15	0.73	8.0	-7.3
High 12	2467	-4.22	-4.37	-1.28	8.0	-9.3
High 13	2472	-9.77	-9.52	-6.63	8.0	-14.6

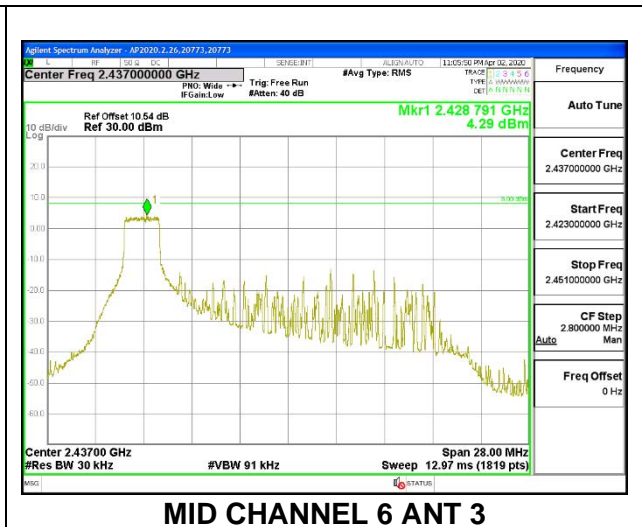
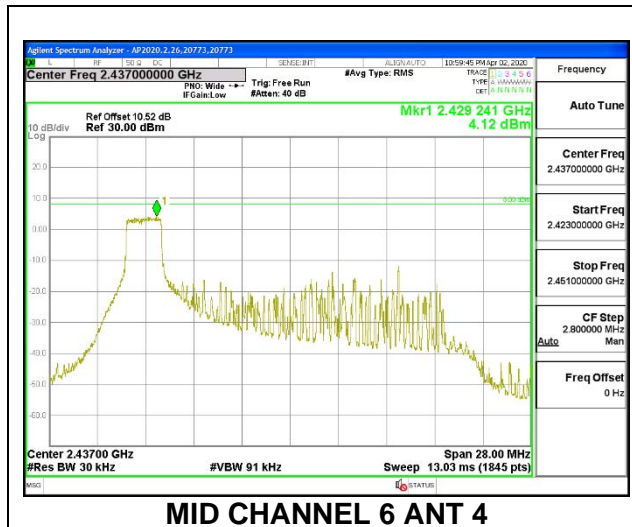

ANT 4 + ANT 3, 2TX 26-Tones, RU Index 4

Duty Cycle CF (dB)	0.00	Included in Calculations of Corr'd PSD				
Channel	Frequency (MHz)	ANT 4 Meas (dBm)	ANT 3 Meas (dBm)	Total Corr'd PSD (dBm)	Limit (dBm/ 3kHz)	Margin (dB)
Low 1	2412	-2.30	-2.07	0.83	8.0	-7.2
Low 2	2417	-0.47	-0.54	2.51	8.0	-5.5
Low 3	2422	1.87	1.69	4.79	8.0	-3.2
Mid 6	2437	2.91	3.04	5.99	8.0	-2.0
High 9	2452	1.52	1.45	4.50	8.0	-3.5
High 10	2457	-0.33	-0.49	2.60	8.0	-5.4
High 11	2462	-2.43	-2.25	0.67	8.0	-7.3
High 12	2467	-4.41	-4.50	-1.44	8.0	-9.4
High 13	2472	-10.02	-9.58	-6.78	8.0	-14.8

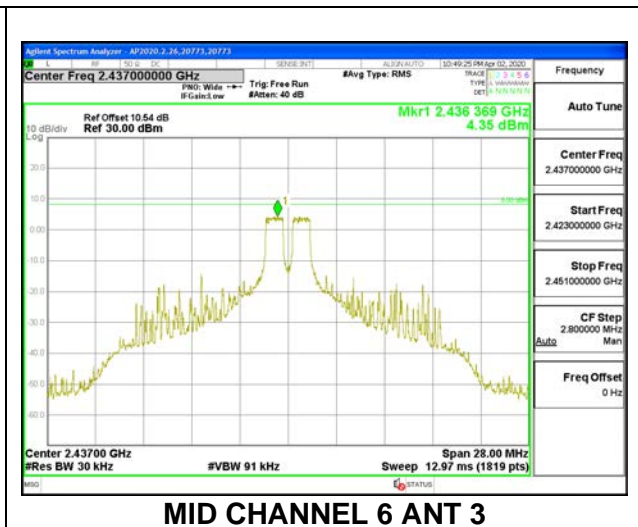
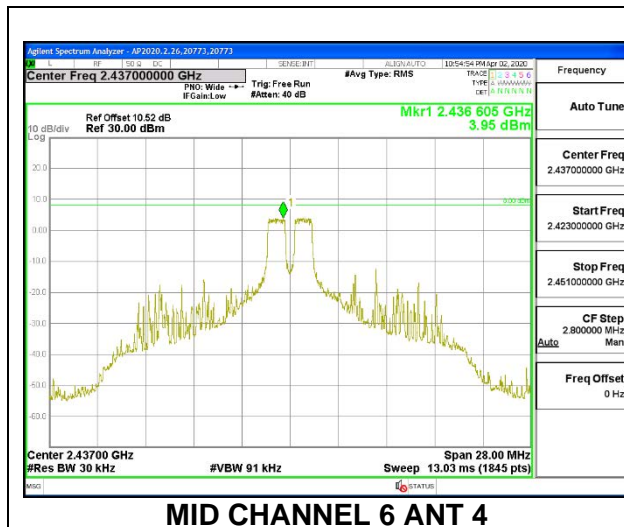

ANT 4 + ANT 3, 2TX 26-Tones, RU Index 8

Duty Cycle CF (dB)		0.00		Included in Calculations of Corr'd PSD		
Channel	Frequency (MHz)	ANT 4 Meas (dBm)	ANT 3 Meas (dBm)	Total Corr'd PSD (dBm)	Limit (dBm/ 3kHz)	Margin (dB)
Low 1	2412	-2.20	-2.27	0.78	8.0	-7.2
Low 2	2417	-0.45	-0.51	2.53	8.0	-5.5
Low 3	2422	1.87	1.80	4.85	8.0	-3.2
Mid 6	2437	2.93	2.96	5.96	8.0	-2.0
High 9	2452	1.42	1.40	4.42	8.0	-3.6
High 10	2457	-0.46	-0.49	2.54	8.0	-5.5
High 11	2462	-2.41	-2.35	0.63	8.0	-7.4
High 12	2467	-4.22	-4.23	-1.21	8.0	-9.2
High 13	2472	-9.40	-9.48	-6.43	8.0	-14.4

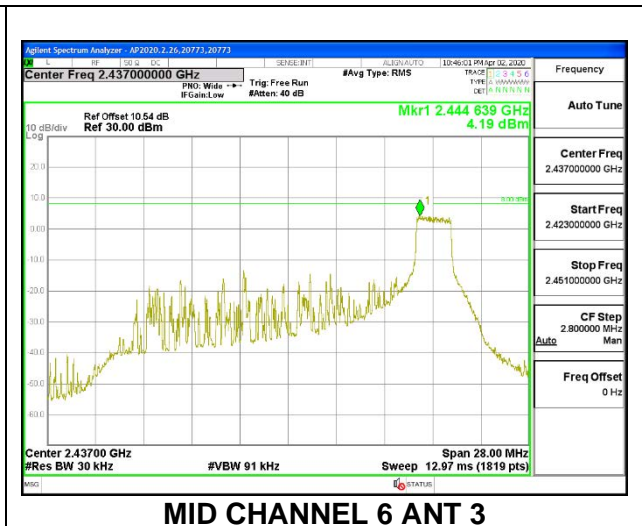
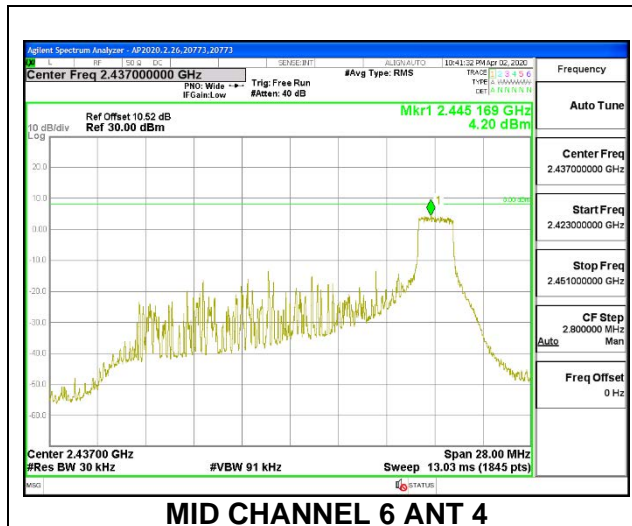

ANT 4 + ANT 3, 2TX 242-Tone RU Index 61

Duty Cycle CF (dB)		Included in Calculations of Corr'd PSD				
Channel	Frequency (MHz)	ANT 4 Meas (dBm)	ANT 3 Meas (dBm)	Total Corr'd PSD (dBm)	Limit (dBm/ 3kHz)	Margin (dB)
Low 1	2412	-10.06	-9.62	-6.82	8.0	-14.8
Low 2	2417	-8.38	-8.34	-5.35	8.0	-13.3
Low 3	2422	-6.30	-6.25	-3.26	8.0	-11.3
Low 4	2427	-3.63	-3.58	-0.59	8.0	-8.6
Mid 6	2437	-3.64	-3.89	-0.75	8.0	-8.8
High 8	2447	-3.57	-3.60	-0.57	8.0	-8.6
High 9	2452	-6.30	-6.81	-3.54	8.0	-11.5
High 10	2457	-7.87	-7.95	-4.90	8.0	-12.9
High 11	2462	-10.20	-9.94	-7.06	8.0	-15.1
High 12	2467	-11.87	-11.70	-8.77	8.0	-16.8
High 13	2472	-19.96	-20.04	-16.99	8.0	-25.0

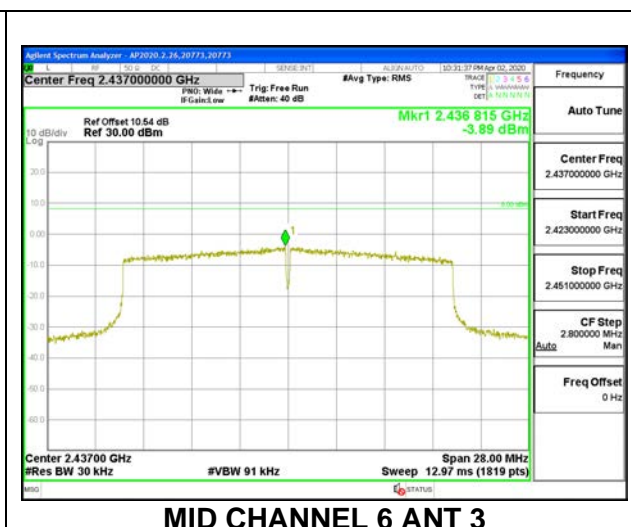
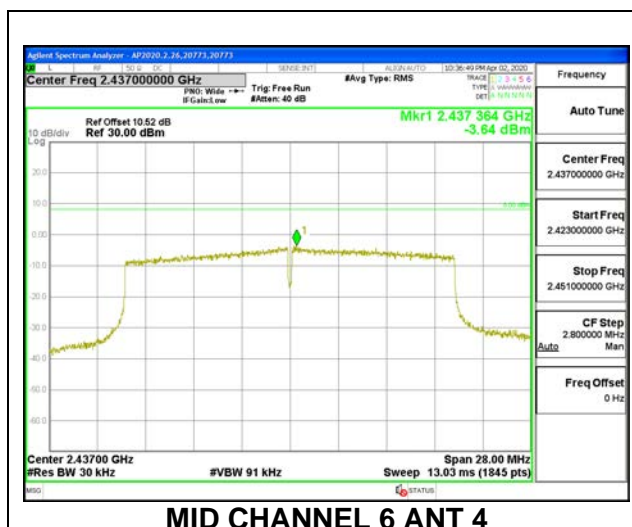

9.6. CONDUCTED SPURIOUS EMISSIONS

LIMITS

FCC §15.247 (d)

RSS-247 5.5

In any 100 kHz bandwidth outside the frequency band in which the spread spectrum or digitally modulated intentional radiator is operating, the radio frequency power that is produced by the intentional radiator shall be at least 20 dB below that in the 100 kHz bandwidth within the band that contains the highest level of the desired power, based on either an RF conducted or a radiated measurement, provided the transmitter demonstrates compliance with the peak conducted power limits. If the transmitter complies with the conducted power limits based on the use of RMS averaging over a time interval, as permitted under paragraph (b)(3) of this section, the attenuation required under this paragraph shall be 30 dB instead of 20 dB. Attenuation below the general limits specified in §15.209(a) is not required. In addition, radiated emissions which fall in the restricted bands, as defined in §15.205(a), must also comply with the radiated emission limits specified in §15.209(a) (see §15.205(c)).

RESULTS

9.6.1. 802.11b MODE 1TX

1TX ANT 4

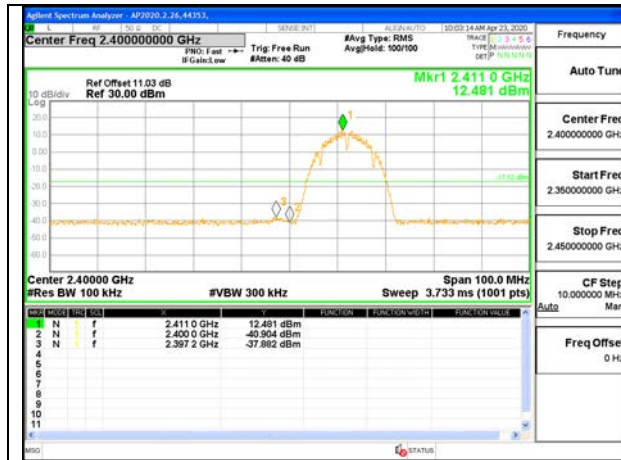

LOW CHANNEL 1 BANDEDGE

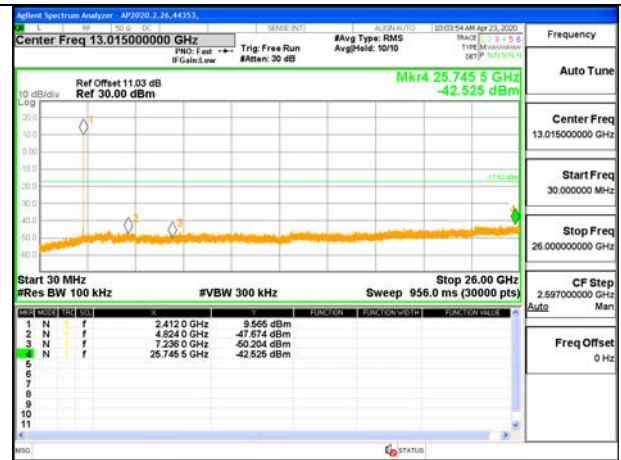

OUT-OF-BAND LOW CHANNEL 1

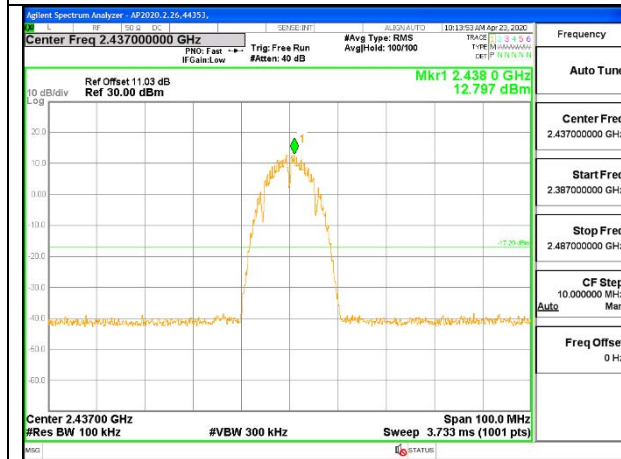

MID CHANNEL REFERENCE LEVEL

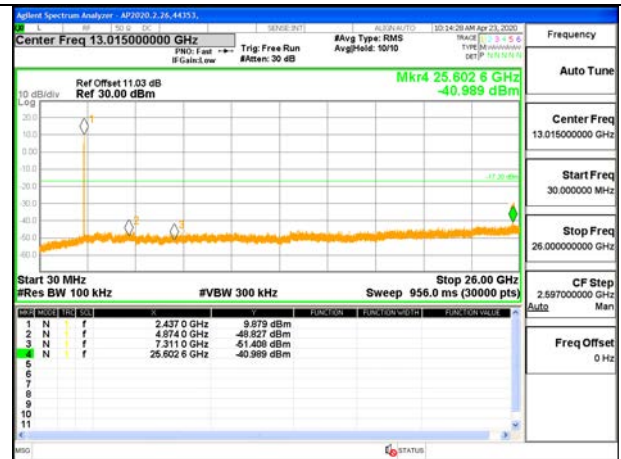

OUT-OF-BAND MID CHANNEL

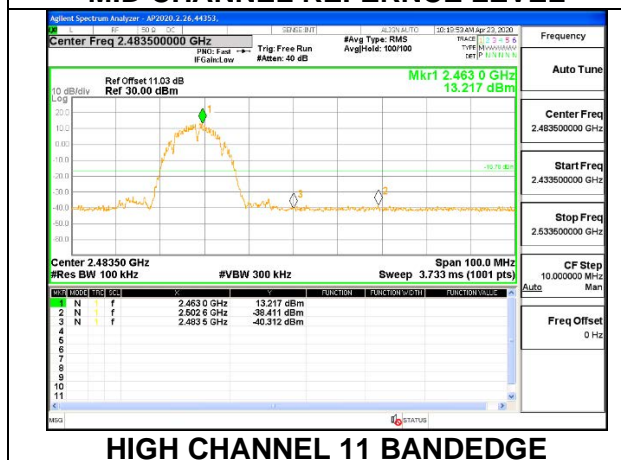

HIGH CHANNEL 11 BANDEDGE

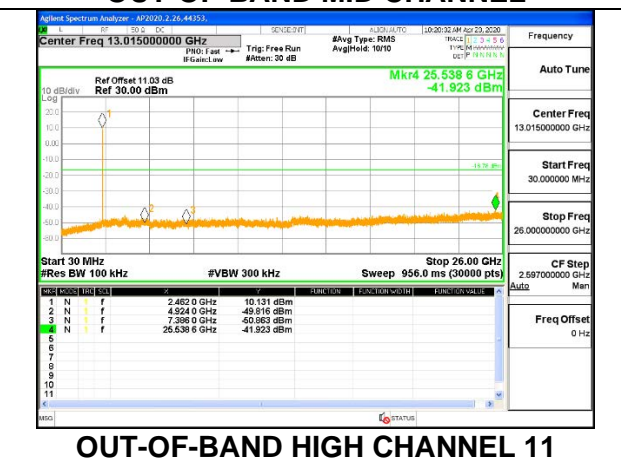

OUT-OF-BAND HIGH CHANNEL 11

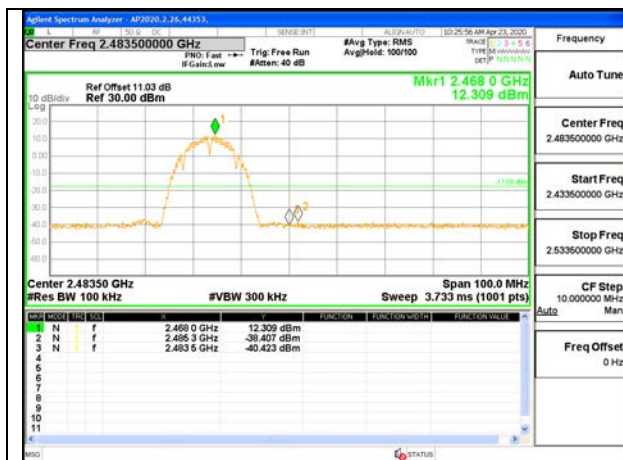

HIGH CHANNEL 12 BANDEDGE

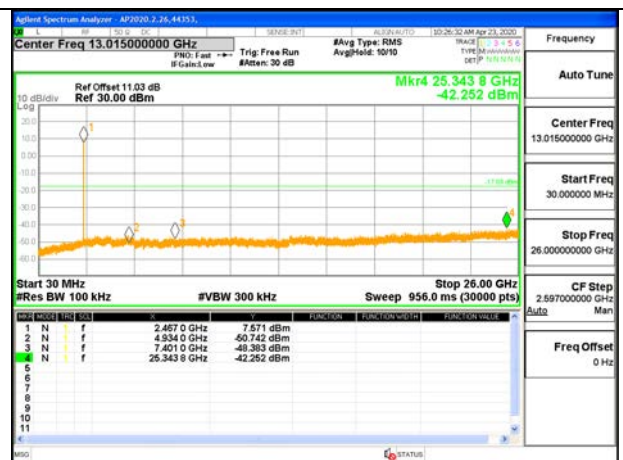

OUT-OF-BAND HIGH CHANNEL 12

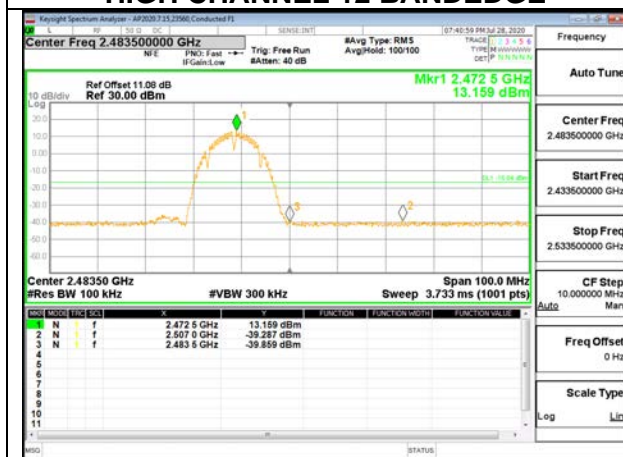

HIGH CHANNEL 13 BANDEDGE

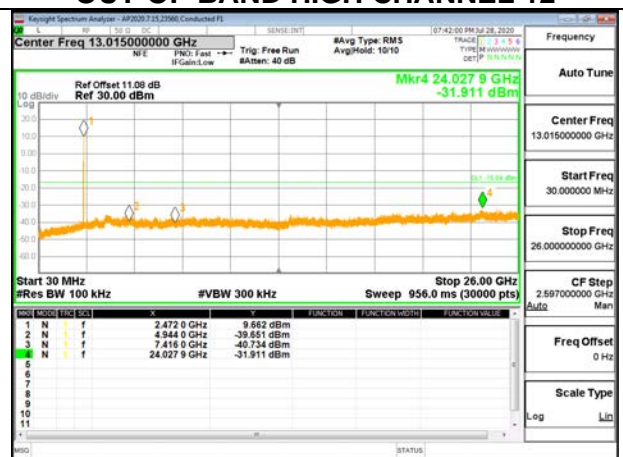

OUT-OF-BAND HIGH CHANNEL 13

1TX ANT 3

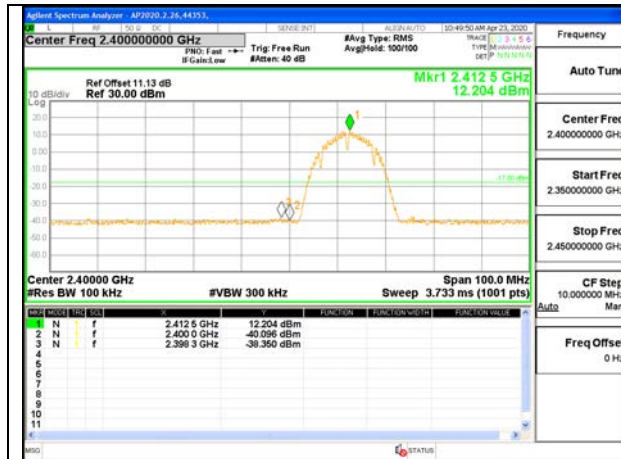

LOW CHANNEL 1 BANDEDGE

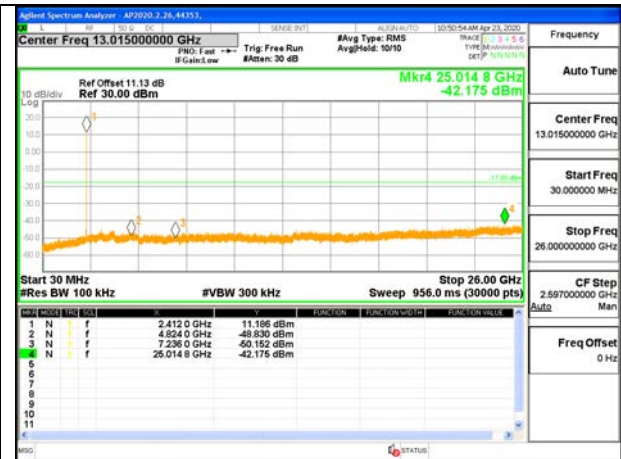

OUT-OF-BAND LOW CHANNEL 1

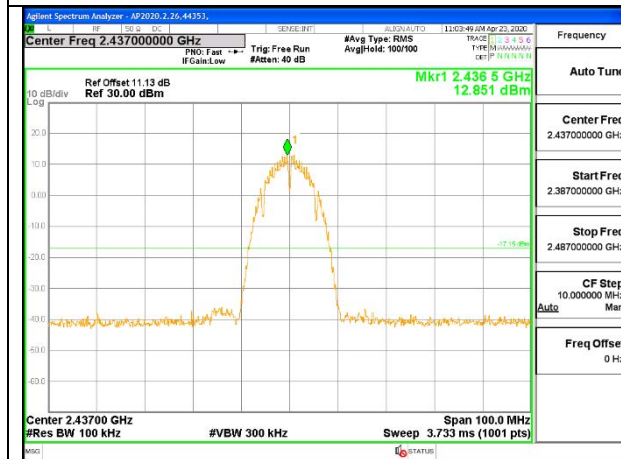

MID CHANNEL REFERENCE LEVEL

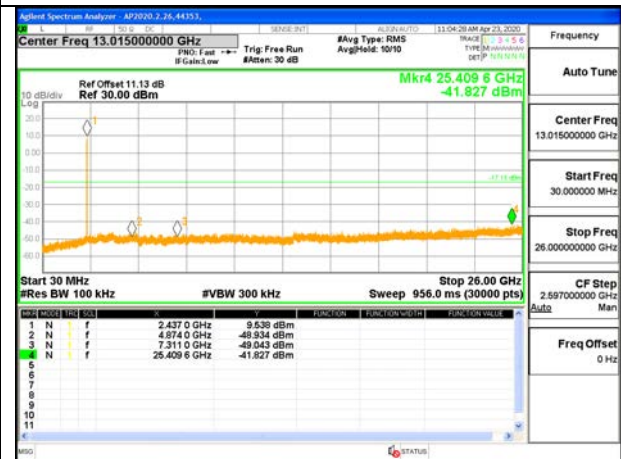

OUT-OF-BAND MID CHANNEL

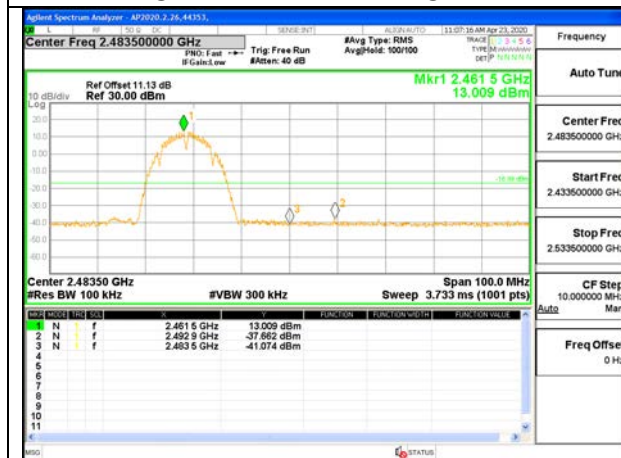

HIGH CHANNEL 11 BANDEDGE



OUT-OF-BAND HIGH CHANNEL 11

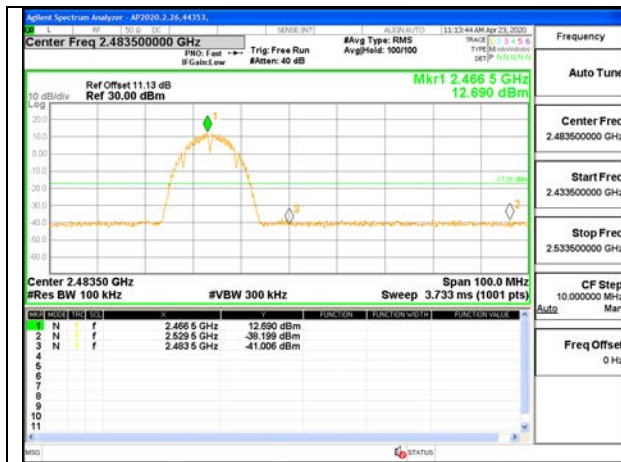

HIGH CHANNEL 12 BANDEDGE

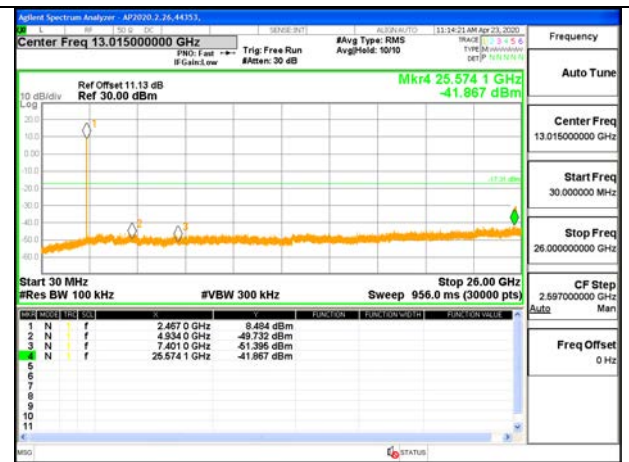

OUT-OF-BAND HIGH CHANNEL 12

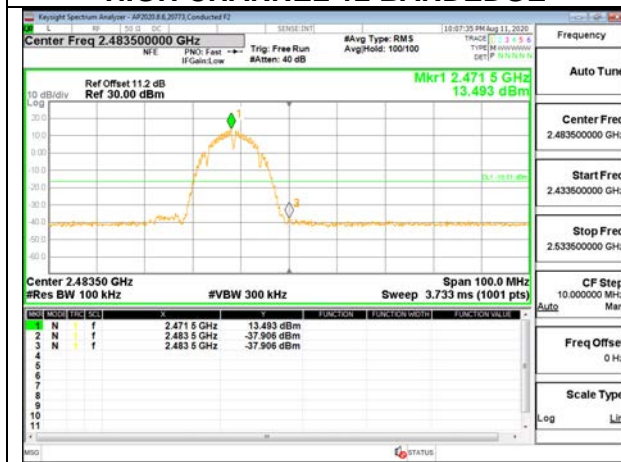

HIGH CHANNEL 13 BANDEDGE

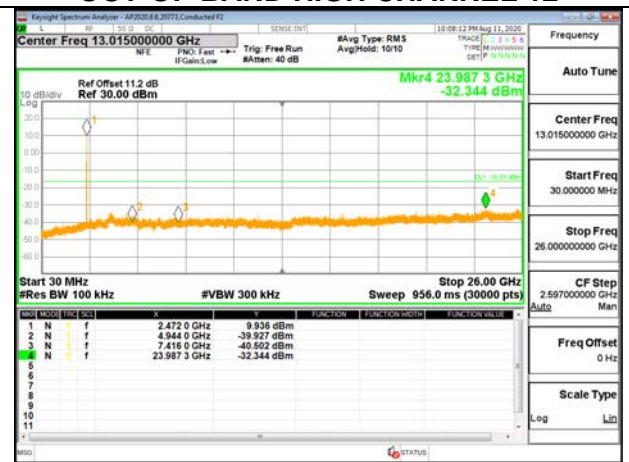

OUT-OF-BAND HIGH CHANNEL 13

9.6.2. 802.11n HT20 MODE

1TX ANT 4

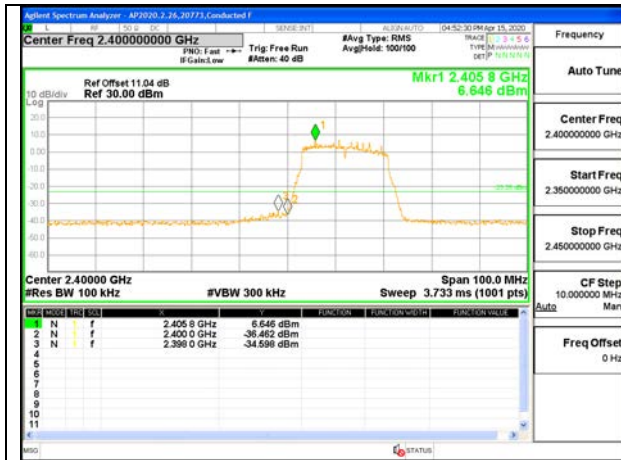

LOW CHANNEL 1 BANDEDGE

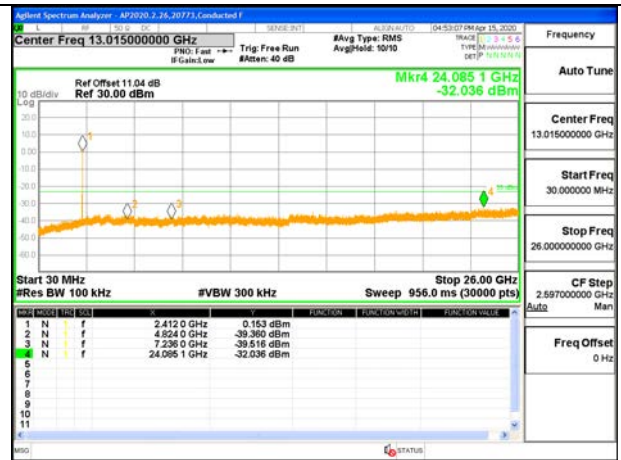

OUT-OF-BAND LOW CHANNEL 1

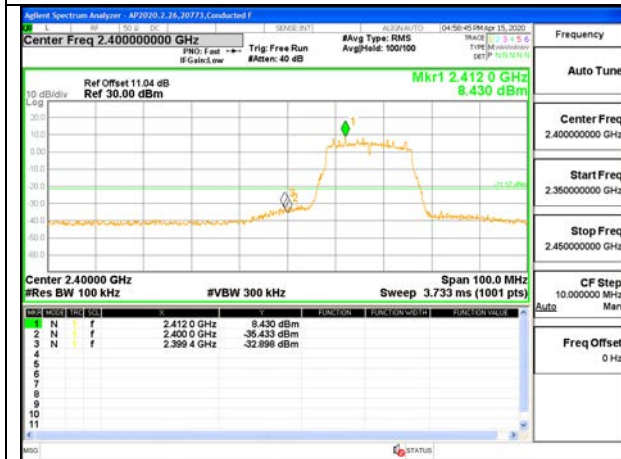

LOW CHANNEL 2 BANDEDGE

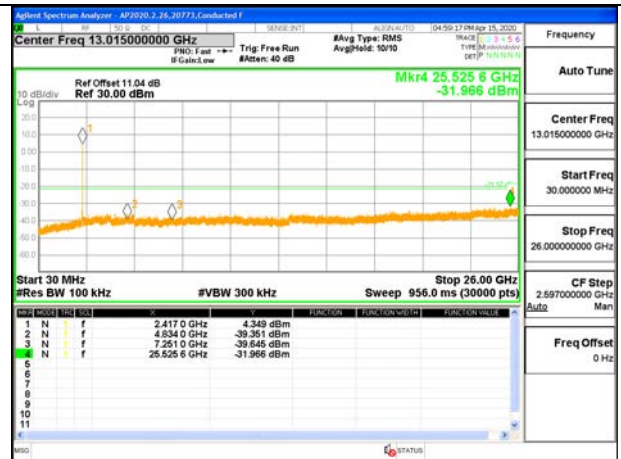

OUT-OF-BAND LOW CHANNEL 2

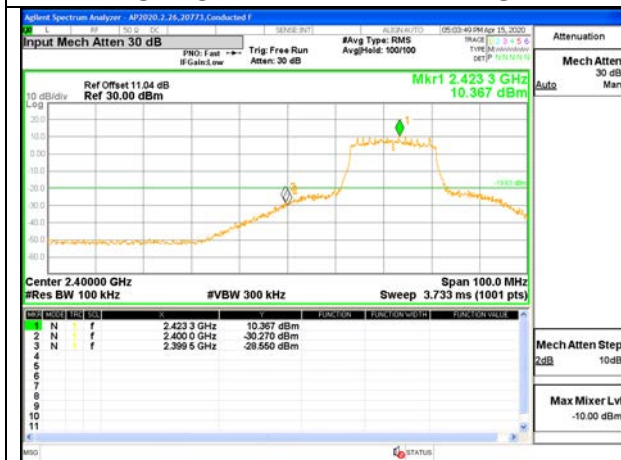

LOW CHANNEL 3 BANDEDGE

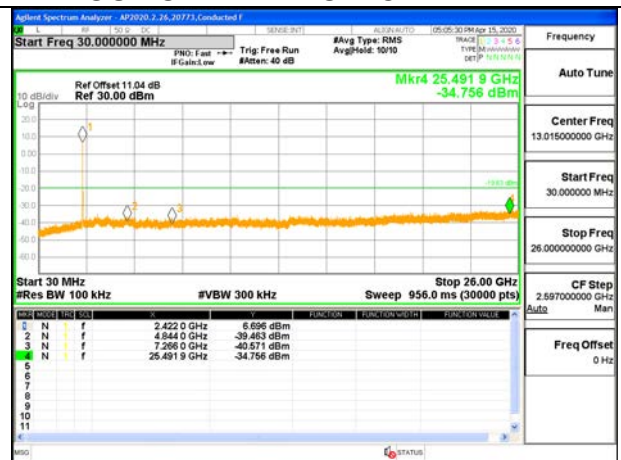

OUT-OF-BAND LOW CHANNEL 3

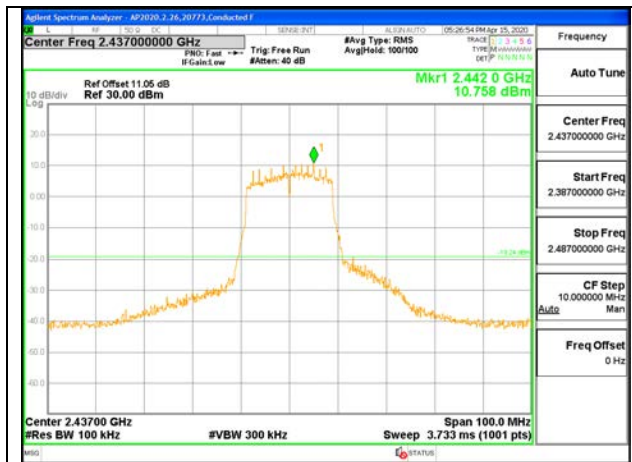

MID CHANNEL REFERENCE LEVEL

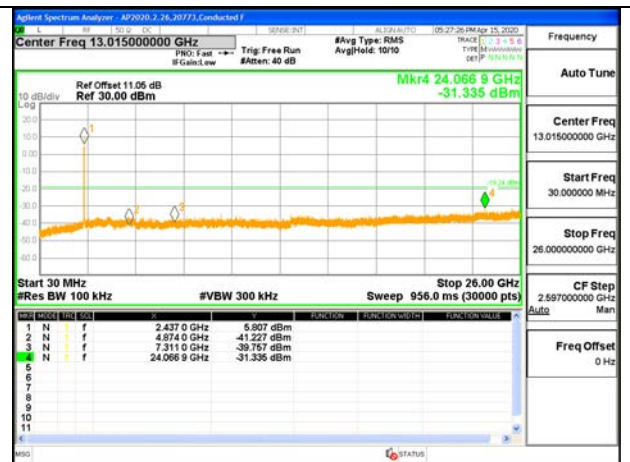

OUT-OF-BAND MID CHANNEL

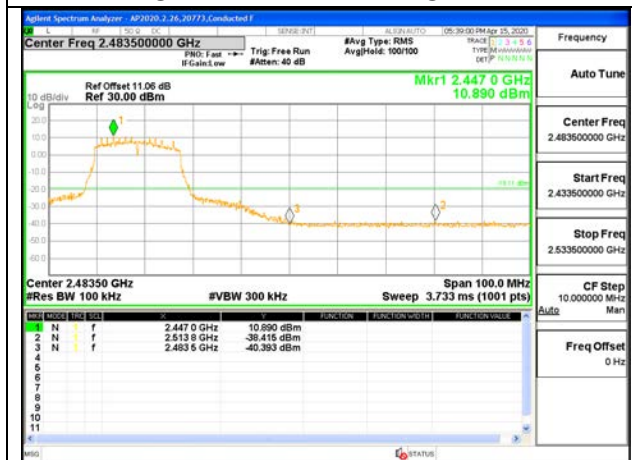

HIGH CHANNEL 9 BANDEDGE

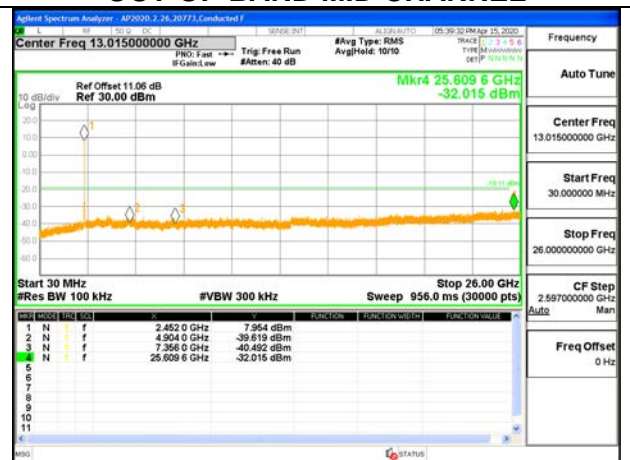

OUT-OF-BAND HIGH CHANNEL 9

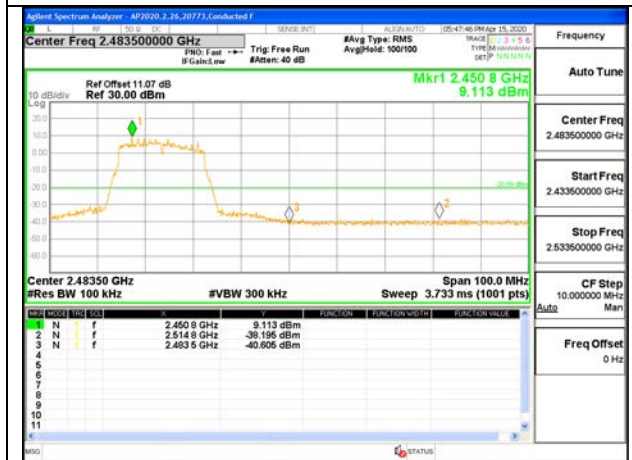

HIGH CHANNEL 10 BANDEDGE

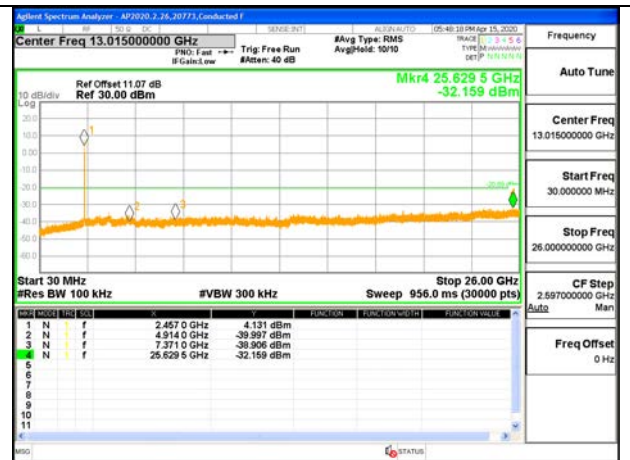

OUT-OF-BAND HIGH CHANNEL 10

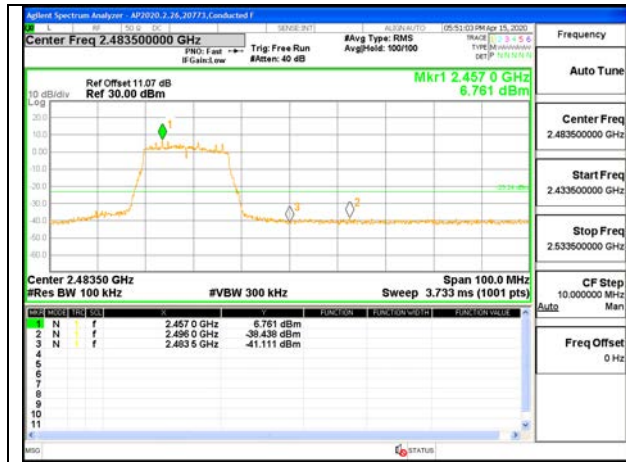

HIGH CHANNEL 11 BANDEDGE

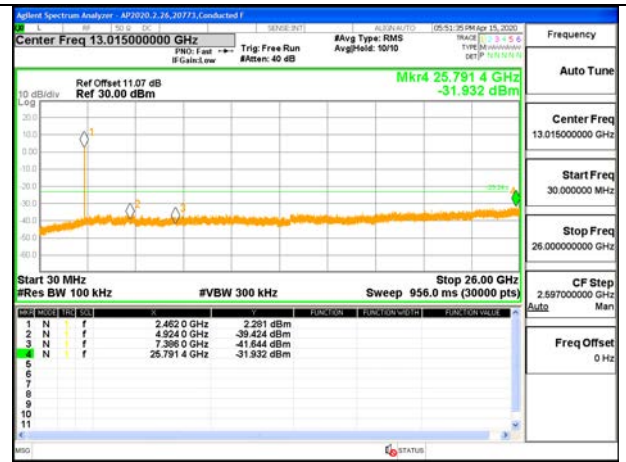

OUT-OF-BAND HIGH CHANNEL 11



HIGH CHANNEL 12 BANDEDGE

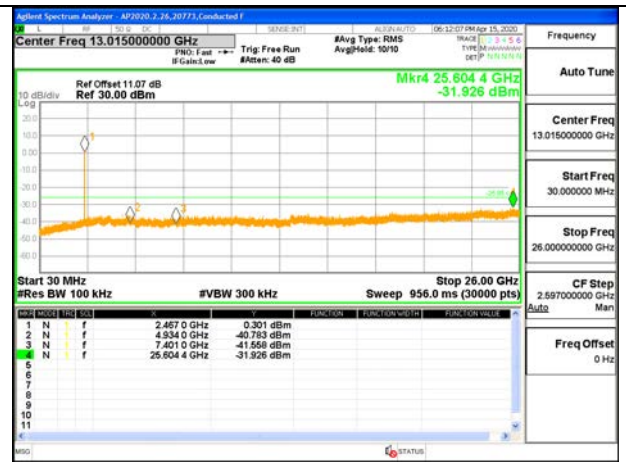

OUT-OF-BAND HIGH CHANNEL 12



HIGH CHANNEL 13 BANDEDGE

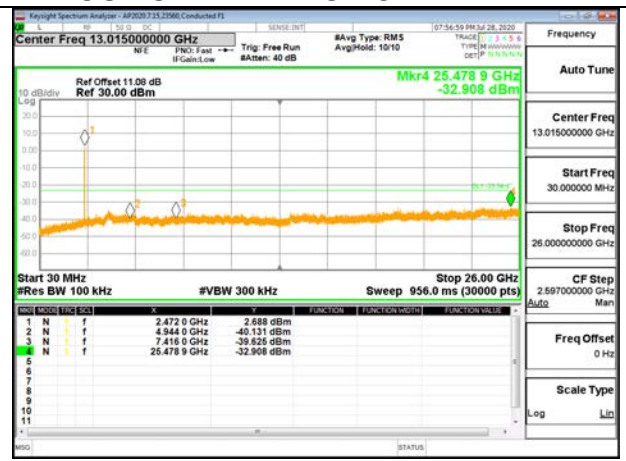

OUT-OF-BAND HIGH CHANNEL 13

1TX ANT 3

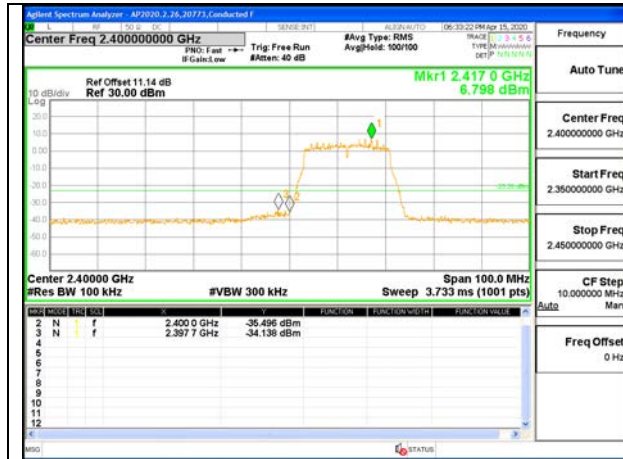

LOW CHANNEL 1 BANDEDGE

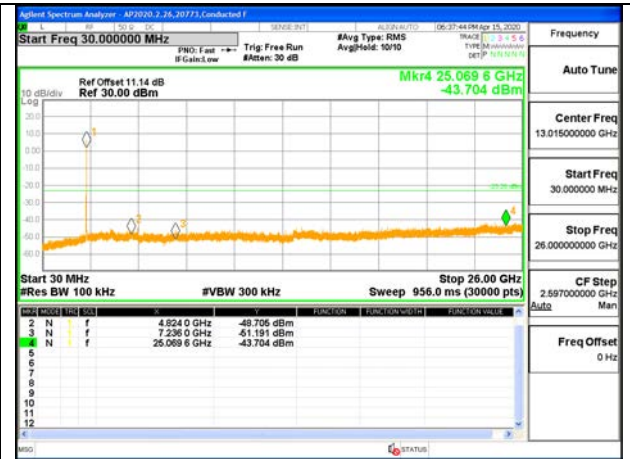

OUT-OF-BAND LOW CHANNEL 1

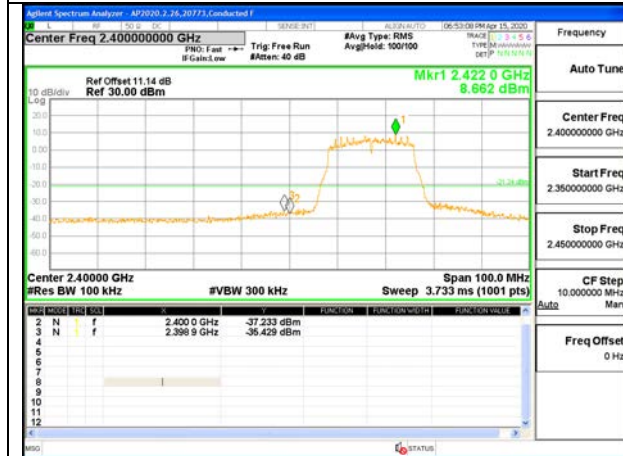

LOW CHANNEL 2 BANDEDGE

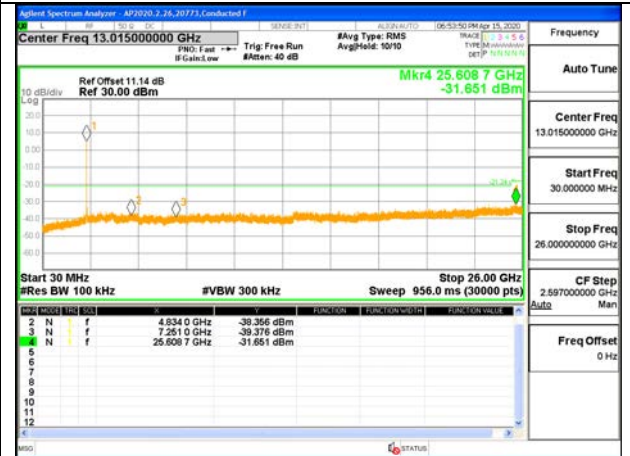

OUT-OF-BAND LOW CHANNEL 2

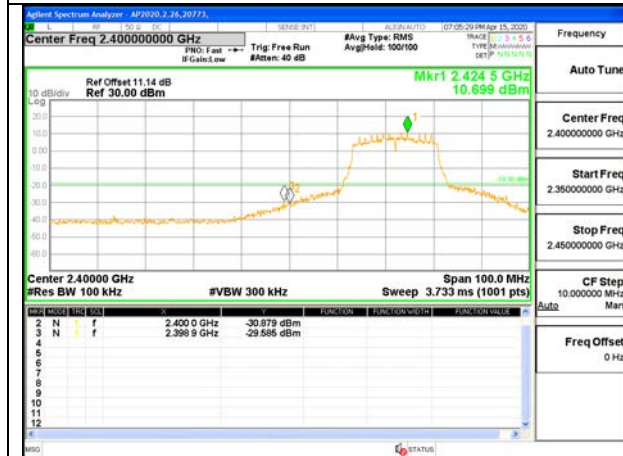

LOW CHANNEL 3 BANDEDGE

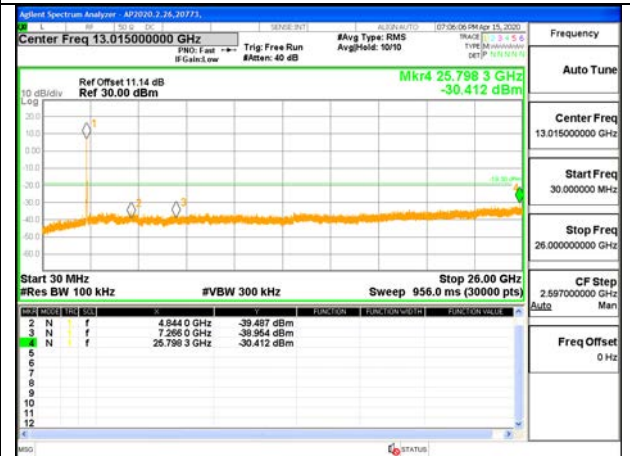

OUT-OF-BAND LOW CHANNEL 3

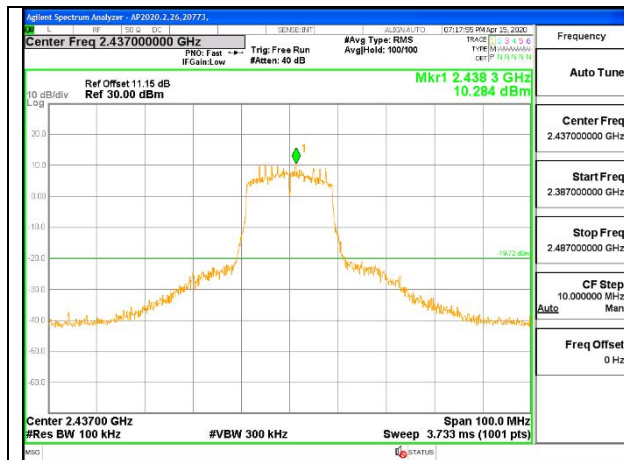

MID CHANNEL REFERENCE LEVEL

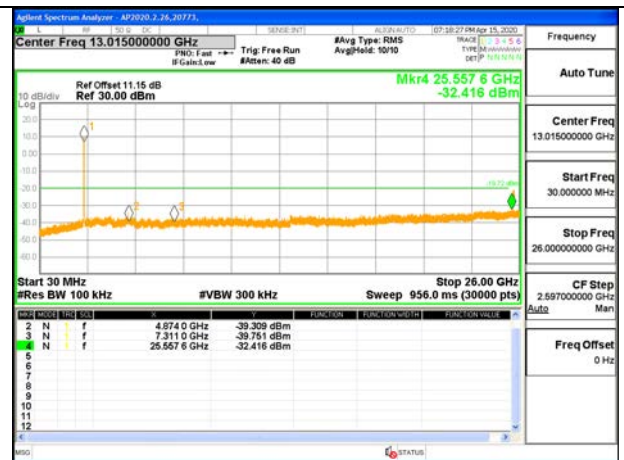

OUT-OF-BAND MID CHANNEL



HIGH CHANNEL 9 BANDEDGE

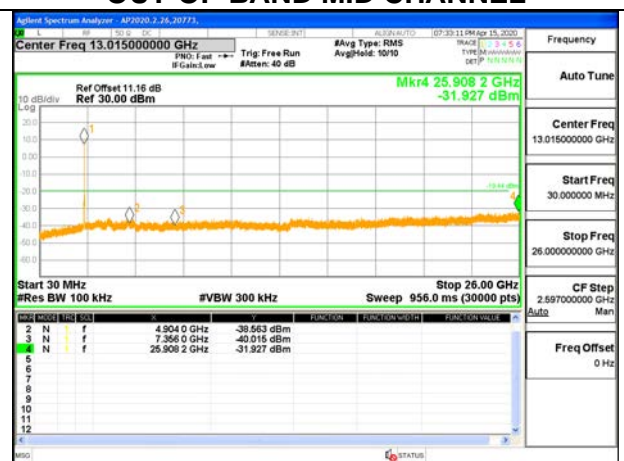

OUT-OF-BAND HIGH CHANNEL 9

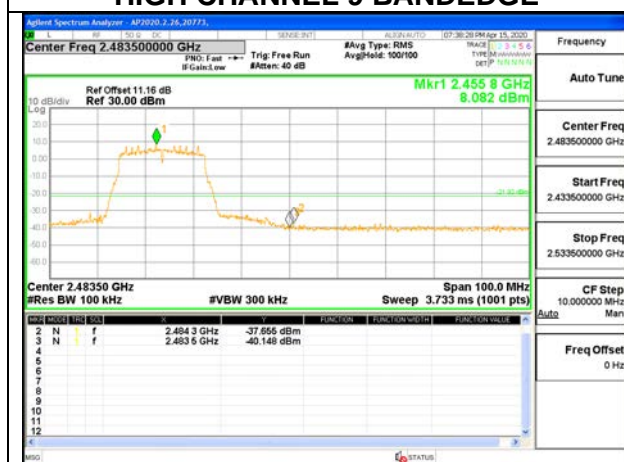

HIGH CHANNEL 10 BANDEDGE

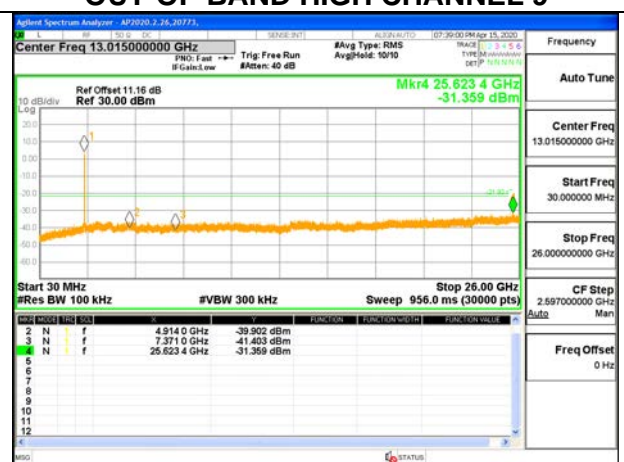

OUT-OF-BAND HIGH CHANNEL 10

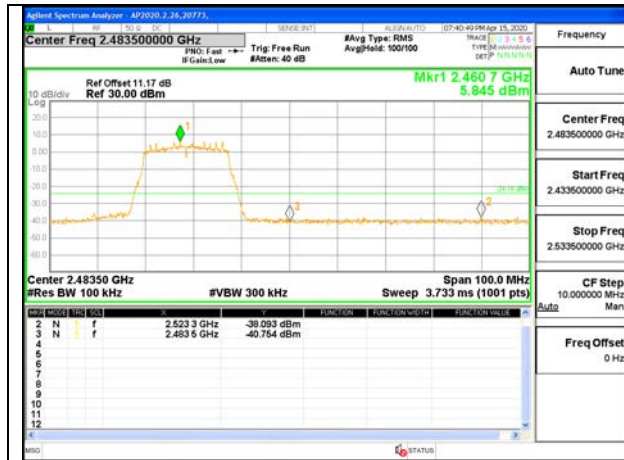

HIGH CHANNEL 11 BANDEDGE

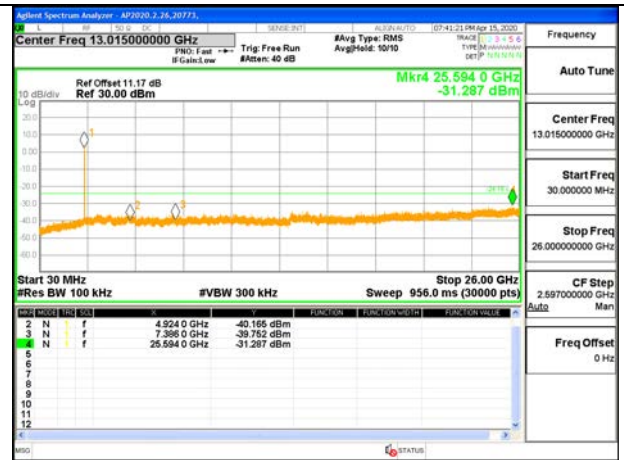

OUT-OF-BAND HIGH CHANNEL 11



HIGH CHANNEL 12 BANDEDGE

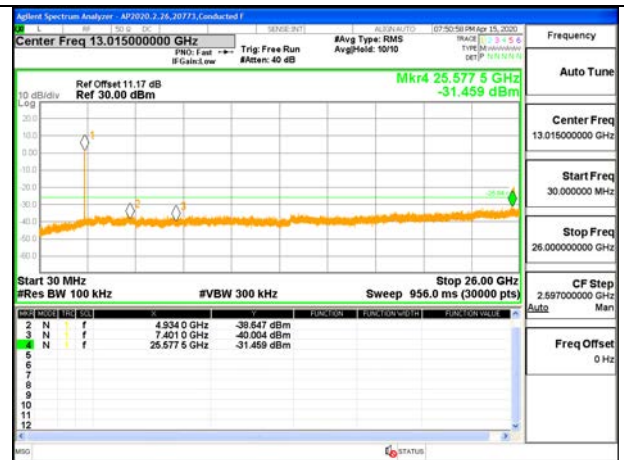

OUT-OF-BAND HIGH CHANNEL 12

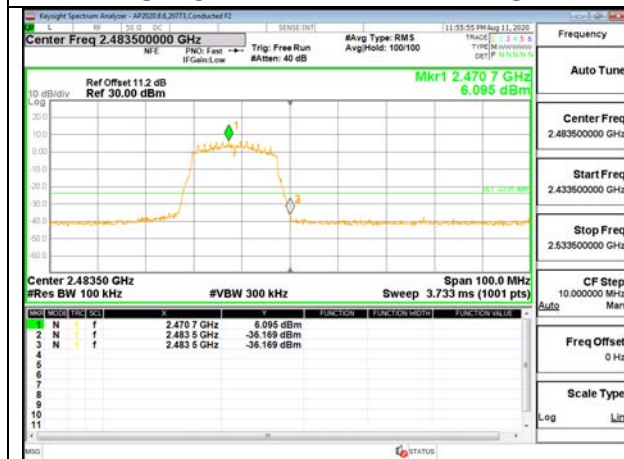

HIGH CHANNEL 13 BANDEDGE

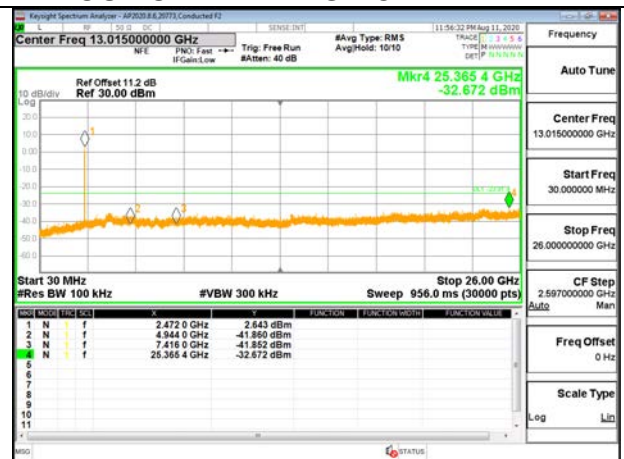

OUT-OF-BAND HIGH CHANNEL 13