



TEST REPORT

Test Report No. : UL-RPT-RP11265293JD07T V2.0

Manufacturer : Apple Inc.
Model No. : A1785
FCC ID : BCG-E3088A
Technology : LTE - Band 12
Test Standard(s) : FCC Part 27 Subpart C

1. This test report shall not be reproduced in full or partial, without the written approval of UL VS LTD.
2. The results in this report apply only to the sample(s) tested.
3. The sample tested is in compliance with the above standard(s).
4. The test results in this report are traceable to the national or international standards.
5. Version 2.0 supersedes all previous versions.

Date of Issue: 03 August 2016

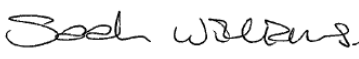
Checked by: 
Sarah Williams
Engineer, Radio Laboratory

Company Signatory: 
Steven White
Service Lead, Radio Laboratory
UL VS LTD



This laboratory is accredited by UKAS. The tests reported herein have been performed in accordance with its terms of accreditation.

UL VS LTD

Pavilion A, Ashwood Park, Ashwood Way, Basingstoke, Hampshire, RG23 8BG, UK
Telephone: +44 (0)1256 312000
Facsimile: +44 (0)1256 312001

This page has been left intentionally blank.

Table of Contents

1. Customer Information.....	4
2. Summary of Testing.....	5
2.1. General Information	5
2.2. Summary of Test Results	5
2.3. Methods and Procedures	5
2.4. Deviations from the Test Specification	5
3. Equipment Under Test (EUT)	6
3.1. Identification of Equipment Under Test (EUT)	6
3.2. Description of EUT	7
3.3. Modifications Incorporated in the EUT	7
3.4. Additional Information Related to Testing	7
3.5. Support Equipment	8
4. Operation and Monitoring of the EUT during Testing	9
4.1. Operating Modes	9
4.2. Configuration and Peripherals	9
4.3. Resource Block Allocation	10
5. Measurements, Examinations and Derived Results.....	11
5.1. General Comments	11
5.2. Test Results	12
5.2.1. Transmitter Output Power (ERP) - LAT	12
5.2.2. Transmitter Output Power (ERP) - UAT	22
5.2.3. Transmitter Occupied Bandwidth	32
5.2.4. Transmitter Radiated Spurious Emissions – LAT	42
5.2.5. Transmitter Radiated Spurious Emissions – UAT	46
5.2.6. Transmitter Radiated Emissions at Band Edges - LAT	49
5.2.7. Transmitter Radiated Emissions at Band Edges - UAT	69
5.2.8. Transmitter Frequency Stability (Temperature Variation)	89
5.2.9. Transmitter Frequency Stability (Voltage Variation)	91
6. Measurement Uncertainty	93
7. Report Revision History	94

1. Customer Information

Company Name:	Apple Inc.
Address:	1 Infinite Loop Cupertino, CA 95014 U.S.A.

2. Summary of Testing

2.1. General Information

Specification Reference:	47CFR27
Specification Title:	Code of Federal Regulations Volume 47 (Telecommunications): Part 27 Subpart C (Miscellaneous Wireless Communication Services)
Site Registration:	209735
Location of Testing:	UL VS LTD, Unit 3 Horizon, Wade Road, Kingsland Business Park, Basingstoke, Hampshire, RG24 8AH, United Kingdom
Test Dates:	02 June 2016 to 25 July 2016

2.2. Summary of Test Results

FCC Reference (47CFR)	Measurement	Result
Part 2.1046 / 27.50(c)(10)	Transmitter Output Power (ERP)	Complied
Part 2.1049	Transmitter Occupied Bandwidth	Complied
Part 2.1053 / 27.53(g)	Transmitter Radiated Spurious Emissions	Complied
Part 2.1053 / 27.53(g)	Transmitter Radiated Emissions at Band Edges	Complied
Part 2.1055 / 27.54	Transmitter Frequency Stability (Temperature and Voltage Variation)	Complied

2.3. Methods and Procedures

Reference:	ANSI/TIA-603-D-2010
Title:	Land Mobile FM or PM Communications Equipment Measurements and Performance Standards
Reference:	FCC KDB 971168 D01 v02r02, October 17 2014
Title:	Measurement Guidance for Certification of Licensed Digital Transmitters

2.4. Deviations from the Test Specification

For the measurements contained within this test report, there were no deviations from, additions to, or exclusions from the test specification identified above.

3. Equipment Under Test (EUT)

3.1. Identification of Equipment Under Test (EUT)

Brand Name:	Apple
Model Name or Number:	A1785
Test Sample Serial Number:	C39RW006HFMH
Test Sample IMEI:	358640070286456 (<i>Radiated LAT Sample</i>)
Hardware Version:	REV1.0
Software Version:	iOS: 14A22580n BB FW: 0.16.01-3
FCC ID:	BCG-E3088A

Brand Name:	Apple
Model Name or Number:	A1785
Test Sample Serial Number:	C39RW00HHFMH
Test Sample IMEI:	358640070309175 (<i>Radiated UAT Sample</i>)
Hardware Version:	REV1.0
Software Version:	iOS: 14A22580n BB FW: 0.16.01-3
FCC ID:	BCG-E3088A

Brand Name:	Apple
Model Name or Number:	A1785
Test Sample Serial Number:	C39RW013HFML
Test Sample IMEI:	358640070269106 (<i>Conducted Sample #1</i>)
Hardware Version:	REV1.0
Software Version:	iOS: 14A22580n BB FW: 0.16.01-3
FCC ID:	BCG-E3088A

Brand Name:	Apple
Model Name or Number:	A1785
Test Sample Serial Number:	C39RP002H940
Test Sample IMEI:	358640070266615 (<i>Conducted Sample #2</i>)
Hardware Version:	REV1.0
Software Version:	iOS: 14A273 BB FW: 0.21.02
FCC ID:	BCG-E3088A

3.2. Description of EUT

The Equipment Under Test was a mobile phone with GSM/GPRS/EGPRS/UMTS/LTE/TD-SCDMA and CDMA technologies. It also supports IEEE 802.11a/b/g/n/ac, Bluetooth®, GPS and NFC. The rechargeable battery is not user accessible.

3.3. Modifications Incorporated in the EUT

No modifications were applied to the EUT during testing.

3.4. Additional Information Related to Testing

Tested Technology:	LTE Band 12		
Type of Equipment	Transceiver		
Channel Bandwidth:	1.4, 3, 5 & 10 MHz		
Modulation Type:	QPSK & 16QAM		
Duty Cycle:	100%		
Antenna Type:	Integral		
Antenna Gain (LAT):	-4.49 dBd		
Antenna Gain (UAT):	-5.46 dBd		
Power Supply Requirement:	Nominal	3.8 VDC	
	Minimum	3.5 VDC	
	Maximum	4.4 VDC	
Transmit Frequency Range:	699 MHz to 716 MHz		
Channels Tested:	Channel Bandwidth (MHz)	N_{ul}	Frequency of Uplink (MHz)
Bottom Channel	1.4	23017	699.7
	3	23025	700.5
	5	23035	701.5
	10	23060	704.0
Middle Channel	All	23095	707.5
Top Channel	1.4	23173	715.3
	3	23165	714.5
	5	23155	713.5
	10	23130	711.0

3.5. Support Equipment

The following support equipment was used to exercise the EUT during testing:

Description:	Laptop PC
Brand Name:	Dell
Model Name or Number:	Latitude E5410
Serial Number:	UL Asset No. 00763

Description:	USB diagnostic cable
Brand Name:	Not stated
Model Name or Number:	Kong
Serial Number:	202D5E

Description:	Personal Hands Free (PHF)
Brand Name:	Apple
Model Name or Number:	Apple Ear Plugs
Serial Number:	Not stated

4. Operation and Monitoring of the EUT during Testing

4.1. Operating Modes

The EUT was tested in the following operating mode(s):

- Transmit Mode - The EUT was set to transmit with maximum output power using the required channel bandwidth. QPSK and 16QAM modulations were both tested, with Resource Block allocation as detailed in section 4.3.

4.2. Configuration and Peripherals

The EUT was tested in the following configuration(s):

- The EUT was placed into a non-ui mode by using the teraterm application on a UL laptop PC. Instructions were provided by the customer to enable the baseband and radio (*Cellular_RSE_setup_V3.0.doc*). This enabled the EUT to connect via a radiated link with the Rohde & Schwarz CMW 500 system simulator operating in transceiver mode. The CMW 500 was used to configure the EUT operating mode.
- The device contains two cellular antennas which do not transmit simultaneously.
 - LAT – Lower Antenna (Primary)
 - UAT – Upper Antenna (Secondary)

Both antennas have been tested to demonstrate compliance.

- For the LAT conducted measurements, the RF conducted port was connected with an external RF cable, supplied by the customer.
- For the UAT conducted cellular measurements, the RF conducted port was exposed and extended with a short RF cable supplied by the customer.
- Conducted measurements at temperature and voltage extremes were performed using a conducted sample supplied by the customer. Short DC flying leads were connected internally to the device in place of the battery, and exited through a hole in the casing. These leads were then extended to a DC power supply for testing purposes.
- The EUT was placed in three orthogonal orientations X, Y and Z to determine the worst case orientation for radiated spurious emissions. The worst case orientation was X (EUT positioned horizontally on its side).
- Transmitter radiated spurious emissions tests were performed with the EUT set to transmit with a 10 MHz channel bandwidth with QPSK modulation applied and 1 resource block with 0 offset. This was found to be the worst case modulation scheme with regards to emissions after preliminary investigations and therefore it was deemed to be the worst case.
- The worst-case radiated emission among all accessories, is determined by the manufacturer to be with the headset connected. The compliance lab performed final testing only with the headset attached.
- Transmitter radiated spurious emissions tests were performed with the PHF connected to the EUT.

4.3. Resource Block Allocation

Channel Bandwidth (MHz)	Maximum No. of Resource Blocks	Resource Block / Offset Number					
		Sub Test 1		Sub Test 2		Sub Test 3	
		RB	Offset	RB	Offset	RB	Offset
1.4	6	1	0	1	5	6	0
3	15	1	0	1	14	15	0
5	25	1	0	1	24	25	0
10	50	1	0	1	49	50	0

Transmitter Occupied Bandwidth was carried out using sub test 3, for both QPSK and 16QAM modulation schemes.

Transmitter radiated spurious emissions tests were performed with the EUT set to transmit with a 10 MHz channel bandwidth with QPSK modulation applied and 1 resource block with 0 offset. This was found to be the worst case modulation scheme with regards to emissions after preliminary investigations and therefore it was deemed to be the worst case.

Transmitter Radiated Band Edge Emissions was tested with sub tests 1, 2 and 3 on all supported channel bandwidths using QPSK and 16-QAM modulations.

Transmitter Frequency Stability test was carried out with sub test 3, with a channel bandwidth of 1.4 MHz only.

5. Measurements, Examinations and Derived Results

5.1. General Comments

Measurement uncertainties are evaluated in accordance with current best practice. Our reported expanded uncertainties are based on standard uncertainties, which are multiplied by an appropriate coverage factor to provide a statistical confidence level of approximately 95%. Please refer to *Section 6 Measurement Uncertainty* for details.

In accordance with UKAS requirements all the measurement equipment is on a calibration schedule. All equipment was within the calibration period on the date of testing.

5.2. Test Results

5.2.1. Transmitter Output Power (ERP) - LAT

Test Summary:

Test Engineer:	Keith Tucker	Test Dates:	23 July 2016 & 25 July 2016
Test Sample IMEI:	358640070269106		

FCC Reference:	Parts 2.1046 & 27.50(c)(10)
Test Method Used:	KDB 971168 Section 2.2 footnote 1, Section 5.6 & Notes below

Environmental Conditions:

Temperature (°C):	24 to 25
Relative Humidity (%):	47 to 52

Note(s):

1. The customer stated that the EUT has a maximum antenna gain of -2.3 dBi. As the limit is ERP, the gain in dBi has been converted to dBd. The dBd gain figure has been calculated as:

$$-2.34 \text{ dBi} - 2.15 \text{ dB} = -4.49 \text{ dBd}$$

2. Conducted average power was measured using a calibrated Rohde and Schwarz CMW 500 Wideband Radio Communication Tester.
3. The RF port of the EUT was connected to the Communication Tester via an RF cable and suitable attenuation. An RF level offset was entered on the Communication Tester to compensate for the loss of the attenuator and RF cable.

Test setup:

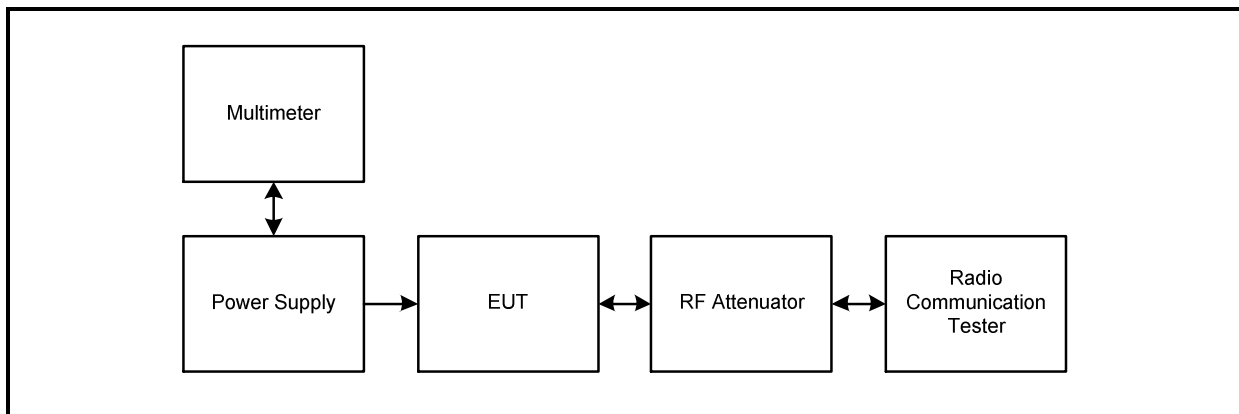

Transmitter Output Power (ERP) (continued)**Results: 1.4 MHz Channel Bandwidth / Bottom Channel / QPSK**

Frequency (MHz)	Resource Block(s)	Resource Block Offset	Conducted RF Power (dBm)	Antenna Gain (dBd)	ERP (dBm)	ERP Limit (dBm)	Margin (dB)	Result
699.7	6	0	22.70	-4.49	18.21	34.77	16.56	Complied
699.7	3	3	24.41	-4.49	19.92	34.77	14.85	Complied
699.7	3	0	24.39	-4.49	19.90	34.77	14.87	Complied
699.7	3	1	24.44	-4.49	19.95	34.77	14.82	Complied
699.7	1	5	24.32	-4.49	19.83	34.77	14.94	Complied
699.7	1	0	24.38	-4.49	19.89	34.77	14.88	Complied
699.7	1	3	24.43	-4.49	19.94	34.77	14.83	Complied

Results: 1.4 MHz Channel Bandwidth / Bottom Channel / 16QAM

Frequency (MHz)	Resource Block(s)	Resource Block Offset	Conducted RF Power (dBm)	Antenna Gain (dBd)	ERP (dBm)	ERP Limit (dBm)	Margin (dB)	Result
699.7	6	0	22.57	-4.49	18.08	34.77	16.69	Complied
699.7	3	3	23.60	-4.49	19.11	34.77	15.66	Complied
699.7	3	0	23.57	-4.49	19.08	34.77	15.69	Complied
699.7	3	1	23.62	-4.49	19.13	34.77	15.64	Complied
699.7	1	5	23.67	-4.49	19.18	34.77	15.59	Complied
699.7	1	0	23.56	-4.49	19.07	34.77	15.70	Complied
699.7	1	3	23.77	-4.49	19.28	34.77	15.49	Complied

Results: 1.4 MHz Channel Bandwidth / Middle Channel / QPSK

Frequency (MHz)	Resource Block(s)	Resource Block Offset	Conducted RF Power (dBm)	Antenna Gain (dBd)	ERP (dBm)	ERP Limit (dBm)	Margin (dB)	Result
707.5	6	0	23.52	-4.49	19.03	34.77	15.74	Complied
707.5	3	3	24.27	-4.49	19.78	34.77	14.99	Complied
707.5	3	0	24.23	-4.49	19.74	34.77	15.03	Complied
707.5	3	1	24.35	-4.49	19.86	34.77	14.91	Complied
707.5	1	5	24.10	-4.49	19.61	34.77	15.16	Complied
707.5	1	0	24.13	-4.49	19.64	34.77	15.13	Complied
707.5	1	3	24.19	-4.49	19.70	34.77	15.07	Complied

Transmitter Output Power (ERP) (continued)**Results: 1.4 MHz Channel Bandwidth / Middle Channel / 16QAM**

Frequency (MHz)	Resource Block(s)	Resource Block Offset	Conducted RF Power (dBm)	Antenna Gain (dBd)	ERP (dBm)	ERP Limit (dBm)	Margin (dB)	Result
707.5	6	0	22.37	-4.49	17.88	34.77	16.89	Complied
707.5	3	3	23.57	-4.49	19.08	34.77	15.69	Complied
707.5	3	0	23.57	-4.49	19.08	34.77	15.69	Complied
707.5	3	1	23.66	-4.49	19.17	34.77	15.60	Complied
707.5	1	5	23.48	-4.49	18.99	34.77	15.78	Complied
707.5	1	0	23.49	-4.49	19.00	34.77	15.77	Complied
707.5	1	3	23.55	-4.49	19.06	34.77	15.71	Complied

Results: 1.4 MHz Channel Bandwidth / Top Channel / QPSK

Frequency (MHz)	Resource Block(s)	Resource Block Offset	Conducted RF Power (dBm)	Antenna Gain (dBd)	ERP (dBm)	ERP Limit (dBm)	Margin (dB)	Result
715.3	6	0	23.49	-4.49	19.00	34.77	15.77	Complied
715.3	3	3	24.22	-4.49	19.73	34.77	15.04	Complied
715.3	3	0	24.18	-4.49	19.69	34.77	15.08	Complied
715.3	3	1	24.21	-4.49	19.72	34.77	15.05	Complied
715.3	1	5	24.12	-4.49	19.63	34.77	15.14	Complied
715.3	1	0	24.15	-4.49	19.66	34.77	15.11	Complied
715.3	1	3	24.18	-4.49	19.69	34.77	15.08	Complied

Results: 1.4 MHz Channel Bandwidth / Top Channel / 16QAM

Frequency (MHz)	Resource Block(s)	Resource Block Offset	Conducted RF Power (dBm)	Antenna Gain (dBd)	ERP (dBm)	ERP Limit (dBm)	Margin (dB)	Result
715.3	6	0	22.35	-4.49	17.86	34.77	16.91	Complied
715.3	3	3	23.71	-4.49	19.22	34.77	15.55	Complied
715.3	3	0	23.58	-4.49	19.09	34.77	15.68	Complied
715.3	3	1	23.60	-4.49	19.11	34.77	15.66	Complied
715.3	1	5	23.32	-4.49	18.83	34.77	15.94	Complied
715.3	1	0	23.33	-4.49	18.84	34.77	15.93	Complied
715.3	1	3	23.37	-4.49	18.88	34.77	15.89	Complied

Transmitter Output Power (ERP) (continued)**Results: 3 MHz Channel Bandwidth / Bottom Channel / QPSK**

Frequency (MHz)	Resource Block(s)	Resource Block Offset	Conducted RF Power (dBm)	Antenna Gain (dBd)	ERP (dBm)	ERP Limit (dBm)	Margin (dB)	Result
700.5	15	0	23.64	-4.49	19.15	34.77	15.62	Complied
700.5	8	7	23.60	-4.49	19.11	34.77	15.66	Complied
700.5	8	0	23.63	-4.49	19.14	34.77	15.63	Complied
700.5	8	4	23.64	-4.49	19.15	34.77	15.62	Complied
700.5	1	14	24.43	-4.49	19.94	34.77	14.83	Complied
700.5	1	0	24.44	-4.49	19.95	34.77	14.82	Complied
700.5	1	7	24.43	-4.49	19.94	34.77	14.83	Complied

Results: 3 MHz Channel Bandwidth / Bottom Channel / 16QAM

Frequency (MHz)	Resource Block(s)	Resource Block Offset	Conducted RF Power (dBm)	Antenna Gain (dBd)	ERP (dBm)	ERP Limit (dBm)	Margin (dB)	Result
700.5	15	0	22.61	-4.49	18.12	34.77	16.65	Complied
700.5	8	7	22.58	-4.49	18.09	34.77	16.68	Complied
700.5	8	0	22.59	-4.49	18.10	34.77	16.67	Complied
700.5	8	4	22.61	-4.49	18.12	34.77	16.65	Complied
700.5	1	14	23.72	-4.49	19.23	34.77	15.54	Complied
700.5	1	0	23.76	-4.49	19.27	34.77	15.50	Complied
700.5	1	7	23.80	-4.49	19.31	34.77	15.46	Complied

Results: 3 MHz Channel Bandwidth / Middle Channel / QPSK

Frequency (MHz)	Resource Block(s)	Resource Block Offset	Conducted RF Power (dBm)	Antenna Gain (dBd)	ERP (dBm)	ERP Limit (dBm)	Margin (dB)	Result
707.5	15	0	23.62	-4.49	19.13	34.77	15.64	Complied
707.5	8	7	23.48	-4.49	18.99	34.77	15.78	Complied
707.5	8	0	23.51	-4.49	19.02	34.77	15.75	Complied
707.5	8	4	23.53	-4.49	19.04	34.77	15.73	Complied
707.5	1	14	24.25	-4.49	19.76	34.77	15.01	Complied
707.5	1	0	24.24	-4.49	19.75	34.77	15.02	Complied
707.5	1	7	24.34	-4.49	19.85	34.77	14.92	Complied

Transmitter Output Power (ERP) (continued)**Results: 3 MHz Channel Bandwidth / Middle Channel / 16QAM**

Frequency (MHz)	Resource Block(s)	Resource Block Offset	Conducted RF Power (dBm)	Antenna Gain (dBd)	ERP (dBm)	ERP Limit (dBm)	Margin (dB)	Result
707.5	15	0	22.47	-4.49	17.98	34.77	16.79	Complied
707.5	8	7	22.54	-4.49	18.05	34.77	16.72	Complied
707.5	8	0	22.58	-4.49	18.09	34.77	16.68	Complied
707.5	8	4	22.59	-4.49	18.10	34.77	16.67	Complied
707.5	1	14	23.47	-4.49	18.98	34.77	15.79	Complied
707.5	1	0	23.56	-4.49	19.07	34.77	15.70	Complied
707.5	1	7	23.62	-4.49	19.13	34.77	15.64	Complied

Results: 3 MHz Channel Bandwidth / Top Channel / QPSK

Frequency (MHz)	Resource Block(s)	Resource Block Offset	Conducted RF Power (dBm)	Antenna Gain (dBd)	ERP (dBm)	ERP Limit (dBm)	Margin (dB)	Result
714.5	15	0	23.55	-4.49	19.06	34.77	15.71	Complied
714.5	8	7	23.49	-4.49	19.00	34.77	15.77	Complied
714.5	8	0	23.42	-4.49	18.93	34.77	15.84	Complied
714.5	8	4	23.50	-4.49	19.01	34.77	15.76	Complied
714.5	1	14	24.15	-4.49	19.66	34.77	15.11	Complied
714.5	1	0	24.15	-4.49	19.66	34.77	15.11	Complied
714.5	1	7	24.19	-4.49	19.70	34.77	15.07	Complied

Results: 3 MHz Channel Bandwidth / Top Channel / 16QAM

Frequency (MHz)	Resource Block(s)	Resource Block Offset	Conducted RF Power (dBm)	Antenna Gain (dBd)	ERP (dBm)	ERP Limit (dBm)	Margin (dB)	Result
714.5	15	0	22.41	-4.49	17.92	34.77	16.85	Complied
714.5	8	7	22.66	-4.49	18.17	34.77	16.60	Complied
714.5	8	0	22.69	-4.49	18.20	34.77	16.57	Complied
714.5	8	4	22.67	-4.49	18.18	34.77	16.59	Complied
714.5	1	14	23.98	-4.49	19.49	34.77	15.28	Complied
714.5	1	0	23.98	-4.49	19.49	34.77	15.28	Complied
714.5	1	7	24.02	-4.49	19.53	34.77	15.24	Complied

Transmitter Output Power (ERP) (continued)**Results: 5 MHz Channel Bandwidth / Bottom Channel / QPSK**

Frequency (MHz)	Resource Block(s)	Resource Block Offset	Conducted RF Power (dBm)	Antenna Gain (dBd)	ERP (dBm)	ERP Limit (dBm)	Margin (dB)	Result
701.5	25	0	23.65	-4.49	19.16	34.77	15.61	Complied
701.5	12	13	23.62	-4.49	19.13	34.77	15.64	Complied
701.5	12	0	23.65	-4.49	19.16	34.77	15.61	Complied
701.5	12	7	23.62	-4.49	19.13	34.77	15.64	Complied
701.5	1	24	24.44	-4.49	19.95	34.77	14.82	Complied
701.5	1	0	24.36	-4.49	19.87	34.77	14.90	Complied
701.5	1	12	24.32	-4.49	19.83	34.77	14.94	Complied

Results: 5 MHz Channel Bandwidth / Bottom Channel / 16QAM

Frequency (MHz)	Resource Block(s)	Resource Block Offset	Conducted RF Power (dBm)	Antenna Gain (dBd)	ERP (dBm)	ERP Limit (dBm)	Margin (dB)	Result
701.5	25	0	22.56	-4.49	18.07	34.77	16.70	Complied
701.5	12	13	22.61	-4.49	18.12	34.77	16.65	Complied
701.5	12	0	22.63	-4.49	18.14	34.77	16.63	Complied
701.5	12	7	22.67	-4.49	18.18	34.77	16.59	Complied
701.5	1	24	23.91	-4.49	19.42	34.77	15.35	Complied
701.5	1	0	23.96	-4.49	19.47	34.77	15.30	Complied
701.5	1	12	23.89	-4.49	19.40	34.77	15.37	Complied

Results: 5 MHz Channel Bandwidth / Middle Channel / QPSK

Frequency (MHz)	Resource Block(s)	Resource Block Offset	Conducted RF Power (dBm)	Antenna Gain (dBd)	ERP (dBm)	ERP Limit (dBm)	Margin (dB)	Result
707.5	25	0	23.52	-4.49	19.03	34.77	15.74	Complied
707.5	12	13	23.45	-4.49	18.96	34.77	15.81	Complied
707.5	12	0	23.56	-4.49	19.07	34.77	15.70	Complied
707.5	12	7	23.58	-4.49	19.09	34.77	15.68	Complied
707.5	1	24	24.34	-4.49	19.85	34.77	14.92	Complied
707.5	1	0	24.34	-4.49	19.85	34.77	14.92	Complied
707.5	1	12	24.30	-4.49	19.81	34.77	14.96	Complied

Transmitter Output Power (ERP) (continued)**Results: 5 MHz Channel Bandwidth / Middle Channel / 16QAM**

Frequency (MHz)	Resource Block(s)	Resource Block Offset	Conducted RF Power (dBm)	Antenna Gain (dBd)	ERP (dBm)	ERP Limit (dBm)	Margin (dB)	Result
707.5	25	0	22.44	-4.49	17.95	34.77	16.82	Complied
707.5	12	13	22.36	-4.49	17.87	34.77	16.90	Complied
707.5	12	0	22.50	-4.49	18.01	34.77	16.76	Complied
707.5	12	7	22.52	-4.49	18.03	34.77	16.74	Complied
707.5	1	24	23.57	-4.49	19.08	34.77	15.69	Complied
707.5	1	0	23.63	-4.49	19.14	34.77	15.63	Complied
707.5	1	12	23.55	-4.49	19.06	34.77	15.71	Complied

Results: 5 MHz Channel Bandwidth / Top Channel / QPSK

Frequency (MHz)	Resource Block(s)	Resource Block Offset	Conducted RF Power (dBm)	Antenna Gain (dBd)	ERP (dBm)	ERP Limit (dBm)	Margin (dB)	Result
713.5	25	0	23.52	-4.49	19.03	34.77	15.74	Complied
713.5	12	13	23.49	-4.49	19.00	34.77	15.77	Complied
713.5	12	0	23.51	-4.49	19.02	34.77	15.75	Complied
713.5	12	7	23.54	-4.49	19.05	34.77	15.72	Complied
713.5	1	24	24.34	-4.49	19.85	34.77	14.92	Complied
713.5	1	0	24.33	-4.49	19.84	34.77	14.93	Complied
713.5	1	12	24.27	-4.49	19.78	34.77	14.99	Complied

Results: 5 MHz Channel Bandwidth / Top Channel / 16QAM

Frequency (MHz)	Resource Block(s)	Resource Block Offset	Conducted RF Power (dBm)	Antenna Gain (dBd)	ERP (dBm)	ERP Limit (dBm)	Margin (dB)	Result
713.5	25	0	22.41	-4.49	17.92	34.77	16.85	Complied
713.5	12	13	22.49	-4.49	18.00	34.77	16.77	Complied
713.5	12	0	22.50	-4.49	18.01	34.77	16.76	Complied
713.5	12	7	22.50	-4.49	18.01	34.77	16.76	Complied
713.5	1	24	23.42	-4.49	18.93	34.77	15.84	Complied
713.5	1	0	23.45	-4.49	18.96	34.77	15.81	Complied
713.5	1	12	23.37	-4.49	18.88	34.77	15.89	Complied

Transmitter Output Power (ERP) (continued)**Results: 10 MHz Channel Bandwidth / Bottom Channel / QPSK**

Frequency (MHz)	Resource Block(s)	Resource Block Offset	Conducted RF Power (dBm)	Antenna Gain (dBd)	ERP (dBm)	ERP Limit (dBm)	Margin (dB)	Result
704.0	50	0	23.63	-4.49	19.14	34.77	15.63	Complied
704.0	25	24	23.55	-4.49	19.06	34.77	15.71	Complied
704.0	25	0	23.62	-4.49	19.13	34.77	15.64	Complied
704.0	25	12	23.64	-4.49	19.15	34.77	15.62	Complied
704.0	1	49	24.32	-4.49	19.83	34.77	14.94	Complied
704.0	1	0	24.26	-4.49	19.77	34.77	15.00	Complied
704.0	1	24	24.26	-4.49	19.77	34.77	15.00	Complied

Results: 10 MHz Channel Bandwidth / Bottom Channel / 16QAM

Frequency (MHz)	Resource Block(s)	Resource Block Offset	Conducted RF Power (dBm)	Antenna Gain (dBd)	ERP (dBm)	ERP Limit (dBm)	Margin (dB)	Result
704.0	50	0	22.54	-4.49	18.05	34.77	16.72	Complied
704.0	25	24	22.59	-4.49	18.10	34.77	16.67	Complied
704.0	25	0	22.67	-4.49	18.18	34.77	16.59	Complied
704.0	25	12	22.65	-4.49	18.16	34.77	16.61	Complied
704.0	1	49	23.61	-4.49	19.12	34.77	15.65	Complied
704.0	1	0	23.66	-4.49	19.17	34.77	15.60	Complied
704.0	1	24	23.65	-4.49	19.16	34.77	15.61	Complied

Results: 10 MHz Channel Bandwidth / Middle Channel / QPSK

Frequency (MHz)	Resource Block(s)	Resource Block Offset	Conducted RF Power (dBm)	Antenna Gain (dBd)	ERP (dBm)	ERP Limit (dBm)	Margin (dB)	Result
707.5	50	0	23.52	-4.49	19.03	34.77	15.74	Complied
707.5	25	24	23.42	-4.49	18.93	34.77	15.84	Complied
707.5	25	0	23.60	-4.49	19.11	34.77	15.66	Complied
707.5	25	12	23.53	-4.49	19.04	34.77	15.73	Complied
707.5	1	49	24.13	-4.49	19.64	34.77	15.13	Complied
707.5	1	0	24.19	-4.49	19.70	34.77	15.07	Complied
707.5	1	24	24.21	-4.49	19.72	34.77	15.05	Complied

Transmitter Output Power (ERP) (continued)**Results: 10 MHz Channel Bandwidth / Middle Channel / 16QAM**

Frequency (MHz)	Resource Block(s)	Resource Block Offset	Conducted RF Power (dBm)	Antenna Gain (dBd)	ERP (dBm)	ERP Limit (dBm)	Margin (dB)	Result
707.5	50	0	22.50	-4.49	18.01	34.77	16.76	Complied
707.5	25	24	22.42	-4.49	17.93	34.77	16.84	Complied
707.5	25	0	22.58	-4.49	18.09	34.77	16.68	Complied
707.5	25	12	22.54	-4.49	18.05	34.77	16.72	Complied
707.5	1	49	23.33	-4.49	18.84	34.77	15.93	Complied
707.5	1	0	23.46	-4.49	18.97	34.77	15.80	Complied
707.5	1	24	23.51	-4.49	19.02	34.77	15.75	Complied

Results: 10 MHz Channel Bandwidth / Top Channel / QPSK

Frequency (MHz)	Resource Block(s)	Resource Block Offset	Conducted RF Power (dBm)	Antenna Gain (dBd)	ERP (dBm)	ERP Limit (dBm)	Margin (dB)	Result
711.0	50	0	23.59	-4.49	19.10	34.77	15.67	Complied
711.0	25	24	23.56	-4.49	19.07	34.77	15.70	Complied
711.0	25	0	23.62	-4.49	19.13	34.77	15.64	Complied
711.0	25	12	23.61	-4.49	19.12	34.77	15.65	Complied
711.0	1	49	24.12	-4.49	19.63	34.77	15.14	Complied
711.0	1	0	24.21	-4.49	19.72	34.77	15.05	Complied
711.0	1	24	24.13	-4.49	19.64	34.77	15.13	Complied

Results: 10 MHz Channel Bandwidth / Top Channel / 16QAM

Frequency (MHz)	Resource Block(s)	Resource Block Offset	Conducted RF Power (dBm)	Antenna Gain (dBd)	ERP (dBm)	ERP Limit (dBm)	Margin (dB)	Result
711.0	50	0	22.48	-4.49	17.99	34.77	16.78	Complied
711.0	25	24	22.55	-4.49	18.06	34.77	16.71	Complied
711.0	25	0	22.64	-4.49	18.15	34.77	16.62	Complied
711.0	25	12	22.62	-4.49	18.13	34.77	16.64	Complied
711.0	1	49	23.97	-4.49	19.48	34.77	15.29	Complied
711.0	1	0	24.06	-4.49	19.57	34.77	15.20	Complied
711.0	1	24	24.03	-4.49	19.54	34.77	15.23	Complied

Transmitter Output Power (ERP) (continued)**Test Equipment Used:**

Asset No.	Instrument	Manufacturer	Type No.	Serial No.	Date Calibration Due	Cal. Interval (Months)
M2002	Thermohygrometer	Testo	608-H1	45041825	02 Apr 2017	12
M1869	Wideband Radio Comms Tester	Rohde & Schwarz	CMW500	145923	05 Apr 2017	12
A2845	Attenuator	Radiall	R411.806.121	24325927	Calibrated before use	-
A2844	Attenuator	Radiall	R411.803.121	23404066	Calibrated before use	-
S0562	Power Supply	Thurlby Thandar	PL330QMD	054895	Calibrated before use	-
M1269	Multimeter	Fluke	179	90250210	13 May 2017	12
G0628	Signal Generator	Rohde & Schwarz	SMBV100A	261847	25 Jan 2017	12
M1835	Signal Analyser	Rohde & Schwarz	FSV30	103050	26 Feb 2017	12

5.2.2. Transmitter Output Power (ERP) - UAT

Test Summary:

Test Engineer:	Keith Tucker	Test Date:	14 July 2016
Test Sample IMEI:	358640070269106		

FCC Reference:	Parts 2.1046 & 27.50(c)(10)
Test Method Used:	KDB 971168 Section 2.2 footnote 1, Section 5.6 & Notes below

Environmental Conditions:

Temperature (°C):	24
Relative Humidity (%):	46

Note(s):

1. The customer stated that the EUT has a maximum antenna gain of -3.31 dBi. As the limit is ERP, the gain in dBi has been converted to dBd. The dBd gain figure has been calculated as:

$$-3.31 \text{ dBi} - 2.15 \text{ dB} = -5.46 \text{ dBd}$$
2. Conducted average power was measured using a calibrated Rohde and Schwarz CMW 500 Wideband Radio Communication Tester.
3. The RF port of the EUT was connected to the Communication Tester via an RF cable and suitable attenuation. An RF level offset was entered on the Communication Tester to compensate for the loss of the attenuator and RF cable.

Test setup:

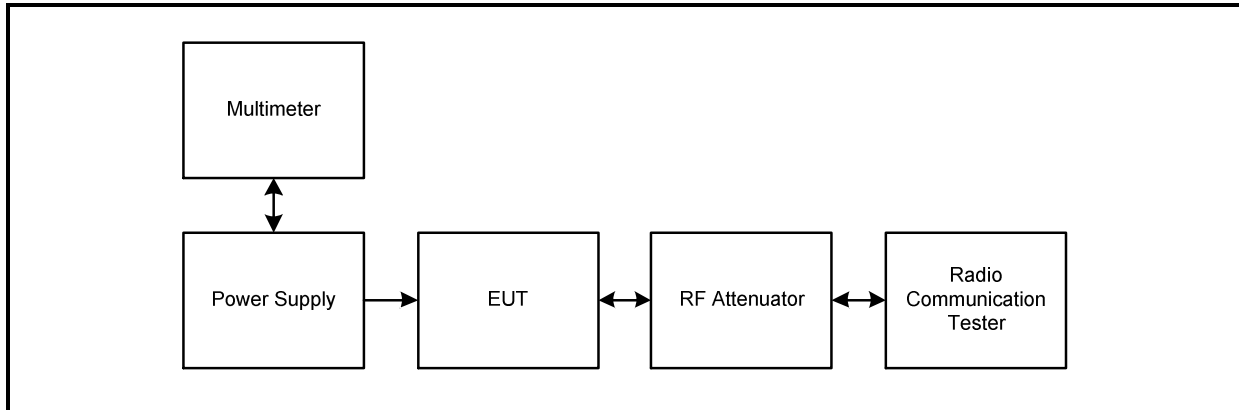

Transmitter Output Power (ERP) (continued)**Results: 1.4 MHz Channel Bandwidth / Bottom Channel / QPSK**

Frequency (MHz)	Resource Block(s)	Resource Block Offset	Conducted RF Power (dBm)	Antenna Gain (dBd)	ERP (dBm)	ERP Limit (dBm)	Margin (dB)	Result
699.7	6	0	21.04	-5.46	15.58	34.77	19.19	Complied
699.7	3	3	21.98	-5.46	16.52	34.77	18.25	Complied
699.7	3	0	21.99	-5.46	16.53	34.77	18.24	Complied
699.7	3	1	21.97	-5.46	16.51	34.77	18.26	Complied
699.7	1	5	21.90	-5.46	16.44	34.77	18.33	Complied
699.7	1	0	21.90	-5.46	16.44	34.77	18.33	Complied
699.7	1	3	21.95	-5.46	16.49	34.77	18.28	Complied

Results: 1.4 MHz Channel Bandwidth / Bottom Channel / 16QAM

Frequency (MHz)	Resource Block(s)	Resource Block Offset	Conducted RF Power (dBm)	Antenna Gain (dBd)	ERP (dBm)	ERP Limit (dBm)	Margin (dB)	Result
699.7	6	0	19.93	-5.46	14.47	34.77	20.30	Complied
699.7	3	3	20.93	-5.46	15.47	34.77	19.30	Complied
699.7	3	0	20.90	-5.46	15.44	34.77	19.33	Complied
699.7	3	1	20.95	-5.46	15.49	34.77	19.28	Complied
699.7	1	5	21.00	-5.46	15.54	34.77	19.23	Complied
699.7	1	0	21.00	-5.46	15.54	34.77	19.23	Complied
699.7	1	3	21.08	-5.46	15.62	34.77	19.15	Complied

Results: 1.4 MHz Channel Bandwidth / Middle Channel / QPSK

Frequency (MHz)	Resource Block(s)	Resource Block Offset	Conducted RF Power (dBm)	Antenna Gain (dBd)	ERP (dBm)	ERP Limit (dBm)	Margin (dB)	Result
707.5	6	0	20.99	-5.46	15.53	34.77	19.24	Complied
707.5	3	3	21.86	-5.46	16.40	34.77	18.37	Complied
707.5	3	0	21.84	-5.46	16.38	34.77	18.39	Complied
707.5	3	1	21.89	-5.46	16.43	34.77	18.34	Complied
707.5	1	5	21.79	-5.46	16.33	34.77	18.44	Complied
707.5	1	0	21.78	-5.46	16.32	34.77	18.45	Complied
707.5	1	3	21.84	-5.46	16.38	34.77	18.39	Complied

Transmitter Output Power (ERP) (continued)**Results: 1.4 MHz Channel Bandwidth / Middle Channel / 16QAM**

Frequency (MHz)	Resource Block(s)	Resource Block Offset	Conducted RF Power (dBm)	Antenna Gain (dBd)	ERP (dBm)	ERP Limit (dBm)	Margin (dB)	Result
707.5	6	0	19.81	-5.46	14.35	34.77	20.42	Complied
707.5	3	3	20.98	-5.46	15.52	34.77	19.25	Complied
707.5	3	0	21.01	-5.46	15.55	34.77	19.22	Complied
707.5	3	1	21.00	-5.46	15.54	34.77	19.23	Complied
707.5	1	5	20.91	-5.46	15.45	34.77	19.32	Complied
707.5	1	0	20.88	-5.46	15.42	34.77	19.35	Complied
707.5	1	3	20.93	-5.46	15.47	34.77	19.30	Complied

Results: 1.4 MHz Channel Bandwidth / Top Channel / QPSK

Frequency (MHz)	Resource Block(s)	Resource Block Offset	Conducted RF Power (dBm)	Antenna Gain (dBd)	ERP (dBm)	ERP Limit (dBm)	Margin (dB)	Result
715.3	6	0	20.99	-5.46	15.53	34.77	19.24	Complied
715.3	3	3	21.96	-5.46	16.50	34.77	18.27	Complied
715.3	3	0	21.97	-5.46	16.51	34.77	18.26	Complied
715.3	3	1	22.00	-5.46	16.54	34.77	18.23	Complied
715.3	1	5	21.93	-5.46	16.47	34.77	18.30	Complied
715.3	1	0	21.91	-5.46	16.45	34.77	18.32	Complied
715.3	1	3	21.99	-5.46	16.53	34.77	18.24	Complied

Results: 1.4 MHz Channel Bandwidth / Top Channel / 16QAM

Frequency (MHz)	Resource Block(s)	Resource Block Offset	Conducted RF Power (dBm)	Antenna Gain (dBd)	ERP (dBm)	ERP Limit (dBm)	Margin (dB)	Result
715.3	6	0	19.95	-5.46	14.49	34.77	20.28	Complied
715.3	3	3	21.19	-5.46	15.73	34.77	19.04	Complied
715.3	3	0	21.17	-5.46	15.71	34.77	19.06	Complied
715.3	3	1	21.20	-5.46	15.74	34.77	19.03	Complied
715.3	1	5	20.93	-5.46	15.47	34.77	19.30	Complied
715.3	1	0	20.94	-5.46	15.48	34.77	19.29	Complied
715.3	1	3	21.00	-5.46	15.54	34.77	19.23	Complied

Transmitter Output Power (ERP) (continued)**Results: 3 MHz Channel Bandwidth / Bottom Channel / QPSK**

Frequency (MHz)	Resource Block(s)	Resource Block Offset	Conducted RF Power (dBm)	Antenna Gain (dBd)	ERP (dBm)	ERP Limit (dBm)	Margin (dB)	Result
700.5	15	0	21.09	-5.46	15.63	34.77	19.14	Complied
700.5	8	7	20.93	-5.46	15.47	34.77	19.30	Complied
700.5	8	0	20.97	-5.46	15.51	34.77	19.26	Complied
700.5	8	4	21.00	-5.46	15.54	34.77	19.23	Complied
700.5	1	14	21.94	-5.46	16.48	34.77	18.29	Complied
700.5	1	0	21.99	-5.46	16.53	34.77	18.24	Complied
700.5	1	7	22.00	-5.46	16.54	34.77	18.23	Complied

Results: 3 MHz Channel Bandwidth / Bottom Channel / 16QAM

Frequency (MHz)	Resource Block(s)	Resource Block Offset	Conducted RF Power (dBm)	Antenna Gain (dBd)	ERP (dBm)	ERP Limit (dBm)	Margin (dB)	Result
700.5	15	0	20.02	-5.46	14.56	34.77	20.21	Complied
700.5	8	7	20.01	-5.46	14.55	34.77	20.22	Complied
700.5	8	0	20.06	-5.46	14.60	34.77	20.17	Complied
700.5	8	4	20.06	-5.46	14.60	34.77	20.17	Complied
700.5	1	14	21.14	-5.46	15.68	34.77	19.09	Complied
700.5	1	0	21.18	-5.46	15.72	34.77	19.05	Complied
700.5	1	7	21.25	-5.46	15.79	34.77	18.98	Complied

Results: 3 MHz Channel Bandwidth / Middle Channel / QPSK

Frequency (MHz)	Resource Block(s)	Resource Block Offset	Conducted RF Power (dBm)	Antenna Gain (dBd)	ERP (dBm)	ERP Limit (dBm)	Margin (dB)	Result
707.5	15	0	21.00	-5.46	15.54	34.77	19.23	Complied
707.5	8	7	20.91	-5.46	15.45	34.77	19.32	Complied
707.5	8	0	20.89	-5.46	15.43	34.77	19.34	Complied
707.5	8	4	20.93	-5.46	15.47	34.77	19.30	Complied
707.5	1	14	21.85	-5.46	16.39	34.77	18.38	Complied
707.5	1	0	21.83	-5.46	16.37	34.77	18.40	Complied
707.5	1	7	21.93	-5.46	16.47	34.77	18.30	Complied

Transmitter Output Power (ERP) (continued)**Results: 3 MHz Channel Bandwidth / Middle Channel / 16QAM**

Frequency (MHz)	Resource Block(s)	Resource Block Offset	Conducted RF Power (dBm)	Antenna Gain (dBd)	ERP (dBm)	ERP Limit (dBm)	Margin (dB)	Result
707.5	15	0	19.94	-5.46	14.48	34.77	20.29	Complied
707.5	8	7	20.00	-5.46	14.54	34.77	20.23	Complied
707.5	8	0	20.01	-5.46	14.55	34.77	20.22	Complied
707.5	8	4	20.09	-5.46	14.63	34.77	20.14	Complied
707.5	1	14	20.99	-5.46	15.53	34.77	19.24	Complied
707.5	1	0	20.92	-5.46	15.46	34.77	19.31	Complied
707.5	1	7	20.96	-5.46	15.50	34.77	19.27	Complied

Results: 3 MHz Channel Bandwidth / Top Channel / QPSK

Frequency (MHz)	Resource Block(s)	Resource Block Offset	Conducted RF Power (dBm)	Antenna Gain (dBd)	ERP (dBm)	ERP Limit (dBm)	Margin (dB)	Result
714.5	15	0	21.08	-5.46	15.62	34.77	19.15	Complied
714.5	8	7	21.01	-5.46	15.55	34.77	19.22	Complied
714.5	8	0	21.05	-5.46	15.59	34.77	19.18	Complied
714.5	8	4	21.06	-5.46	15.60	34.77	19.17	Complied
714.5	1	14	21.97	-5.46	16.51	34.77	18.26	Complied
714.5	1	0	22.00	-5.46	16.54	34.77	18.23	Complied
714.5	1	7	21.99	-5.46	16.53	34.77	18.24	Complied

Results: 3 MHz Channel Bandwidth / Top Channel / 16QAM

Frequency (MHz)	Resource Block(s)	Resource Block Offset	Conducted RF Power (dBm)	Antenna Gain (dBd)	ERP (dBm)	ERP Limit (dBm)	Margin (dB)	Result
714.5	15	0	20.03	-5.46	14.57	34.77	20.20	Complied
714.5	8	7	20.16	-5.46	14.70	34.77	20.07	Complied
714.5	8	0	20.22	-5.46	14.76	34.77	20.01	Complied
714.5	8	4	20.22	-5.46	14.76	34.77	20.01	Complied
714.5	1	14	21.46	-5.46	16.00	34.77	18.77	Complied
714.5	1	0	21.52	-5.46	16.06	34.77	18.71	Complied
714.5	1	7	21.56	-5.46	16.10	34.77	18.67	Complied

Transmitter Output Power (ERP) (continued)**Results: 5 MHz Channel Bandwidth / Bottom Channel / QPSK**

Frequency (MHz)	Resource Block(s)	Resource Block Offset	Conducted RF Power (dBm)	Antenna Gain (dBd)	ERP (dBm)	ERP Limit (dBm)	Margin (dB)	Result
701.5	25	0	21.02	-5.46	15.56	34.77	19.21	Complied
701.5	12	13	20.93	-5.46	15.47	34.77	19.30	Complied
701.5	12	0	20.96	-5.46	15.50	34.77	19.27	Complied
701.5	12	7	21.01	-5.46	15.55	34.77	19.22	Complied
701.5	1	24	21.96	-5.46	16.50	34.77	18.27	Complied
701.5	1	0	21.95	-5.46	16.49	34.77	18.28	Complied
701.5	1	12	21.89	-5.46	16.43	34.77	18.34	Complied

Results: 5 MHz Channel Bandwidth / Bottom Channel / 16QAM

Frequency (MHz)	Resource Block(s)	Resource Block Offset	Conducted RF Power (dBm)	Antenna Gain (dBd)	ERP (dBm)	ERP Limit (dBm)	Margin (dB)	Result
701.5	25	0	19.93	-5.46	14.47	34.77	20.30	Complied
701.5	12	13	20.04	-5.46	14.58	34.77	20.19	Complied
701.5	12	0	20.11	-5.46	14.65	34.77	20.12	Complied
701.5	12	7	20.10	-5.46	14.64	34.77	20.13	Complied
701.5	1	24	21.33	-5.46	15.87	34.77	18.90	Complied
701.5	1	0	21.34	-5.46	15.88	34.77	18.89	Complied
701.5	1	12	21.25	-5.46	15.79	34.77	18.98	Complied

Results: 5 MHz Channel Bandwidth / Middle Channel / QPSK

Frequency (MHz)	Resource Block(s)	Resource Block Offset	Conducted RF Power (dBm)	Antenna Gain (dBd)	ERP (dBm)	ERP Limit (dBm)	Margin (dB)	Result
707.5	25	0	21.04	-5.46	15.58	34.77	19.19	Complied
707.5	12	13	20.95	-5.46	15.49	34.77	19.28	Complied
707.5	12	0	21.00	-5.46	15.54	34.77	19.23	Complied
707.5	12	7	21.06	-5.46	15.60	34.77	19.17	Complied
707.5	1	24	21.97	-5.46	16.51	34.77	18.26	Complied
707.5	1	0	21.98	-5.46	16.52	34.77	18.25	Complied
707.5	1	12	21.92	-5.46	16.46	34.77	18.31	Complied

Transmitter Output Power (ERP) (continued)**Results: 5 MHz Channel Bandwidth / Middle Channel / 16QAM**

Frequency (MHz)	Resource Block(s)	Resource Block Offset	Conducted RF Power (dBm)	Antenna Gain (dBd)	ERP (dBm)	ERP Limit (dBm)	Margin (dB)	Result
707.5	25	0	20.01	-5.46	14.55	34.77	20.22	Complied
707.5	12	13	19.96	-5.46	14.50	34.77	20.27	Complied
707.5	12	0	19.97	-5.46	14.51	34.77	20.26	Complied
707.5	12	7	20.04	-5.46	14.58	34.77	20.19	Complied
707.5	1	24	21.13	-5.46	15.67	34.77	19.10	Complied
707.5	1	0	21.15	-5.46	15.69	34.77	19.08	Complied
707.5	1	12	20.99	-5.46	15.53	34.77	19.24	Complied

Results: 5 MHz Channel Bandwidth / Top Channel / QPSK

Frequency (MHz)	Resource Block(s)	Resource Block Offset	Conducted RF Power (dBm)	Antenna Gain (dBd)	ERP (dBm)	ERP Limit (dBm)	Margin (dB)	Result
713.5	25	0	21.04	-5.46	15.58	34.77	19.19	Complied
713.5	12	13	20.99	-5.46	15.53	34.77	19.24	Complied
713.5	12	0	21.03	-5.46	15.57	34.77	19.20	Complied
713.5	12	7	21.03	-5.46	15.57	34.77	19.20	Complied
713.5	1	24	21.98	-5.46	16.52	34.77	18.25	Complied
713.5	1	0	22.00	-5.46	16.54	34.77	18.23	Complied
713.5	1	12	21.96	-5.46	16.50	34.77	18.27	Complied

Results: 5 MHz Channel Bandwidth / Top Channel / 16QAM

Frequency (MHz)	Resource Block(s)	Resource Block Offset	Conducted RF Power (dBm)	Antenna Gain (dBd)	ERP (dBm)	ERP Limit (dBm)	Margin (dB)	Result
713.5	25	0	20.04	-5.46	14.58	34.77	20.19	Complied
713.5	12	13	20.00	-5.46	14.54	34.77	20.23	Complied
713.5	12	0	20.08	-5.46	14.62	34.77	20.15	Complied
713.5	12	7	20.14	-5.46	14.68	34.77	20.09	Complied
713.5	1	24	21.00	-5.46	15.54	34.77	19.23	Complied
713.5	1	0	20.95	-5.46	15.49	34.77	19.28	Complied
713.5	1	12	20.95	-5.46	15.49	34.77	19.28	Complied

Transmitter Output Power (ERP) (continued)**Results: 10 MHz Channel Bandwidth / Bottom Channel / QPSK**

Frequency (MHz)	Resource Block(s)	Resource Block Offset	Conducted RF Power (dBm)	Antenna Gain (dBd)	ERP (dBm)	ERP Limit (dBm)	Margin (dB)	Result
704.0	50	0	21.13	-5.46	15.67	34.77	19.10	Complied
704.0	25	24	21.00	-5.46	15.54	34.77	19.23	Complied
704.0	25	0	21.08	-5.46	15.62	34.77	19.15	Complied
704.0	25	12	21.10	-5.46	15.64	34.77	19.13	Complied
704.0	1	49	21.91	-5.46	16.45	34.77	18.32	Complied
704.0	1	0	21.94	-5.46	16.48	34.77	18.29	Complied
704.0	1	24	21.92	-5.46	16.46	34.77	18.31	Complied

Results: 10 MHz Channel Bandwidth / Bottom Channel / 16QAM

Frequency (MHz)	Resource Block(s)	Resource Block Offset	Conducted RF Power (dBm)	Antenna Gain (dBd)	ERP (dBm)	ERP Limit (dBm)	Margin (dB)	Result
704.0	50	0	20.05	-5.46	14.59	34.77	20.18	Complied
704.0	25	24	20.08	-5.46	14.62	34.77	20.15	Complied
704.0	25	0	20.11	-5.46	14.65	34.77	20.12	Complied
704.0	25	12	20.15	-5.46	14.69	34.77	20.08	Complied
704.0	1	49	21.09	-5.46	15.63	34.77	19.14	Complied
704.0	1	0	21.12	-5.46	15.66	34.77	19.11	Complied
704.0	1	24	21.11	-5.46	15.65	34.77	19.12	Complied

Results: 10 MHz Channel Bandwidth / Middle Channel / QPSK

Frequency (MHz)	Resource Block(s)	Resource Block Offset	Conducted RF Power (dBm)	Antenna Gain (dBd)	ERP (dBm)	ERP Limit (dBm)	Margin (dB)	Result
707.5	50	0	21.08	-5.46	15.62	34.77	19.15	Complied
707.5	25	24	21.07	-5.46	15.61	34.77	19.16	Complied
707.5	25	0	21.06	-5.46	15.60	34.77	19.17	Complied
707.5	25	12	21.14	-5.46	15.68	34.77	19.09	Complied
707.5	1	49	21.91	-5.46	16.45	34.77	18.32	Complied
707.5	1	0	21.87	-5.46	16.41	34.77	18.36	Complied
707.5	1	24	21.86	-5.46	16.40	34.77	18.37	Complied

Transmitter Output Power (ERP) (continued)**Results: 10 MHz Channel Bandwidth / Middle Channel / 16QAM**

Frequency (MHz)	Resource Block(s)	Resource Block Offset	Conducted RF Power (dBm)	Antenna Gain (dBd)	ERP (dBm)	ERP Limit (dBm)	Margin (dB)	Result
707.5	50	0	20.02	-5.46	14.56	34.77	20.21	Complied
707.5	25	24	20.15	-5.46	14.69	34.77	20.08	Complied
707.5	25	0	20.14	-5.46	14.68	34.77	20.09	Complied
707.5	25	12	20.13	-5.46	14.67	34.77	20.10	Complied
707.5	1	49	21.02	-5.46	15.56	34.77	19.21	Complied
707.5	1	0	20.95	-5.46	15.49	34.77	19.28	Complied
707.5	1	24	20.98	-5.46	15.52	34.77	19.25	Complied

Results: 10 MHz Channel Bandwidth / Top Channel / QPSK

Frequency (MHz)	Resource Block(s)	Resource Block Offset	Conducted RF Power (dBm)	Antenna Gain (dBd)	ERP (dBm)	ERP Limit (dBm)	Margin (dB)	Result
711.0	50	0	21.17	-5.46	15.71	34.77	19.06	Complied
711.0	25	24	21.14	-5.46	15.68	34.77	19.09	Complied
711.0	25	0	21.13	-5.46	15.67	34.77	19.10	Complied
711.0	25	12	21.21	-5.46	15.75	34.77	19.02	Complied
711.0	1	49	21.93	-5.46	16.47	34.77	18.30	Complied
711.0	1	0	21.89	-5.46	16.43	34.77	18.34	Complied
711.0	1	24	22.00	-5.46	16.54	34.77	18.23	Complied

Results: 10 MHz Channel Bandwidth / Top Channel / 16QAM

Frequency (MHz)	Resource Block(s)	Resource Block Offset	Conducted RF Power (dBm)	Antenna Gain (dBd)	ERP (dBm)	ERP Limit (dBm)	Margin (dB)	Result
711.0	50	0	20.14	-5.46	14.68	34.77	20.09	Complied
711.0	25	24	20.19	-5.46	14.73	34.77	20.04	Complied
711.0	25	0	20.22	-5.46	14.76	34.77	20.01	Complied
711.0	25	12	20.28	-5.46	14.82	34.77	19.95	Complied
711.0	1	49	21.51	-5.46	16.05	34.77	18.72	Complied
711.0	1	0	21.51	-5.46	16.05	34.77	18.72	Complied
711.0	1	24	21.56	-5.46	16.10	34.77	18.67	Complied

Transmitter Output Power (ERP) (continued)**Test Equipment Used:**

Asset No.	Instrument	Manufacturer	Type No.	Serial No.	Date Calibration Due	Cal. Interval (Months)
M2002	Thermohygrometer	Testo	608-H1	45041825	02 Apr 2017	12
M1869	Wideband Radio Comms Tester	Rohde & Schwarz	CMW500	145923	05 Apr 2017	12
A2845	Attenuator	Radiall	R411.806.121	24325927	Calibrated before use	-
A2844	Attenuator	Radiall	R411.803.121	23404066	Calibrated before use	-
S0562	Power Supply	Thurlby Thandar	PL330QMD	054895	Calibrated before use	-
M1269	Multimeter	Fluke	179	90250210	13 May 2017	12
G0628	Signal Generator	Rohde & Schwarz	SMBV100A	261847	25 Jan 2017	12
M1835	Signal Analyser	Rohde & Schwarz	FSV30	103050	26 Feb 2017	12

5.2.3. Transmitter Occupied Bandwidth

Test Summary:

Test Engineer:	Keith Tucker	Test Date:	04 July 2016
Test Sample IMEI:	358640070269106		

FCC Reference:	Part 2.1049
Test Method Used:	KDB 971168 Section 4.2

Environmental Conditions:

Temperature (°C):	23
Relative Humidity (%):	46

Note(s):

1. Occupied bandwidth (99% bandwidth) was measured using a signal analyser occupied bandwidth function.
2. Measurements were performed with the EUT transmitting with QPSK and 16QAM modulation schemes, with resource blocks settings as detailed in section 4.3 of this report.
3. The RF port of the EUT was connected to the signal analyser via RF cables, directional coupler and suitable attenuation.

Test setup:

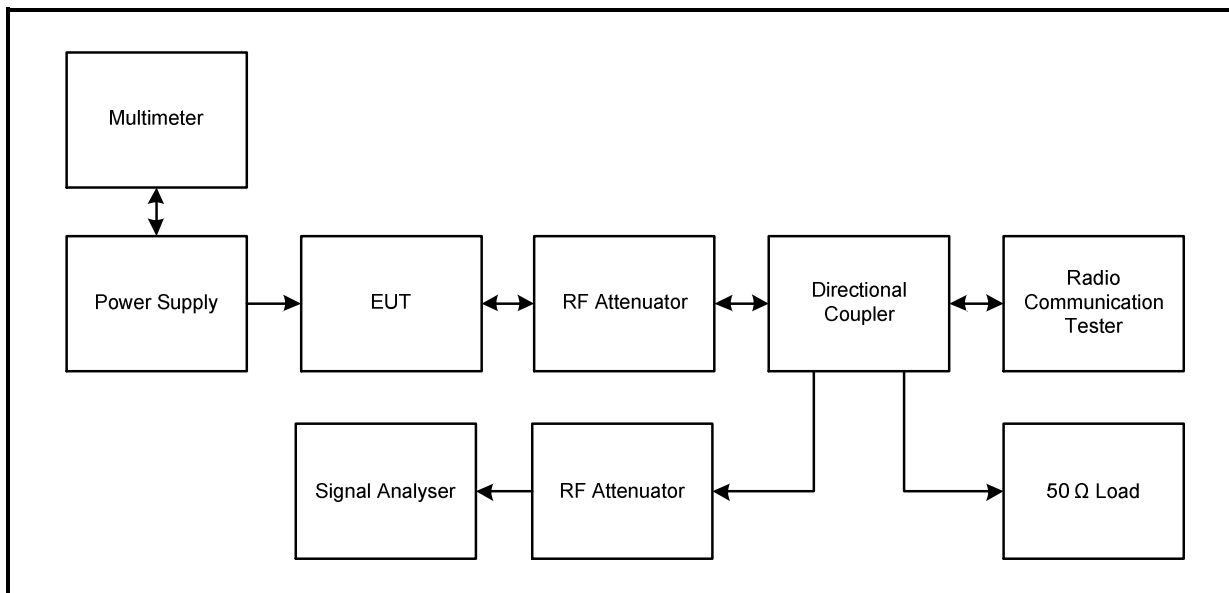

Transmitter Occupied Bandwidth (continued)

Results: 1.4 MHz Channel Bandwidth / QPSK

Channel	Resource Block(s)	Resource Block Offset	Resolution Bandwidth (kHz)	Video Bandwidth (kHz)	Occupied Bandwidth (MHz)
Bottom	6	0	30	100	1.106
Middle	6	0	30	100	1.090
Top	6	0	30	100	1.098

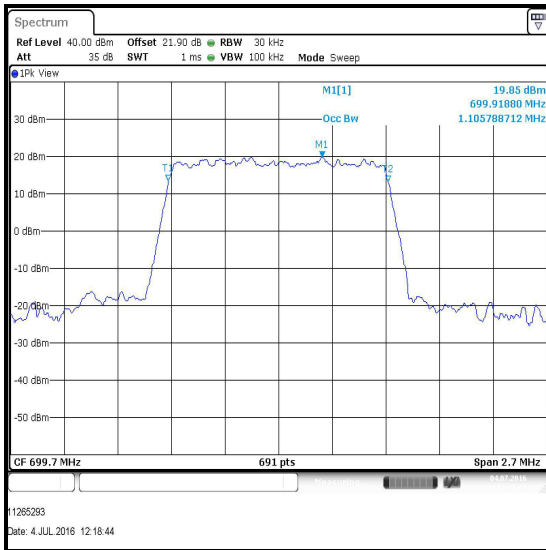

Bottom Channel / QPSK

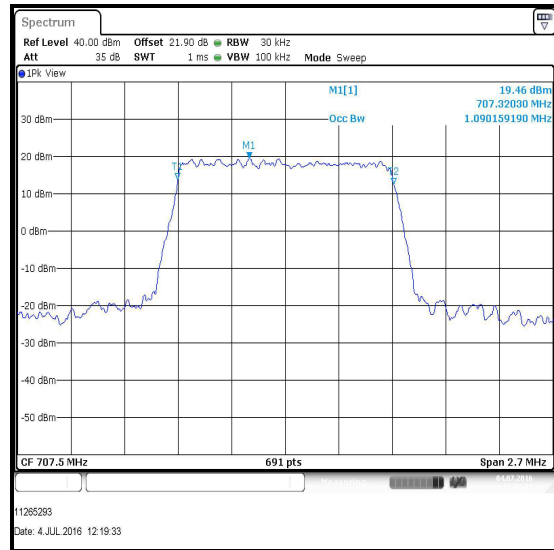

Middle Channel / QPSK

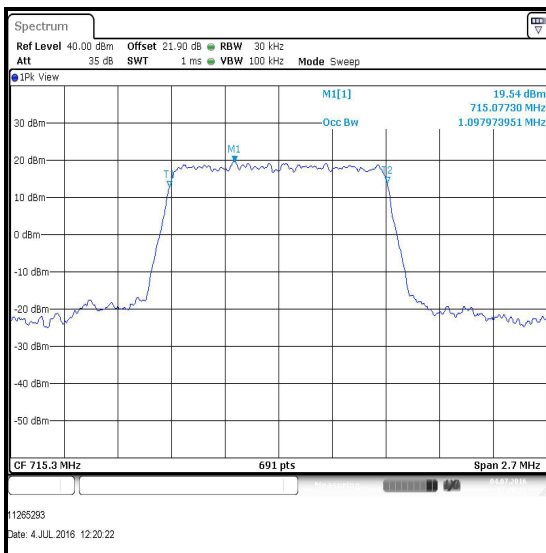

Top Channel / QPSK

Transmitter Occupied Bandwidth (continued)

Results: 1.4 MHz Channel Bandwidth / 16QAM

Channel	Resource Block(s)	Resource Block Offset	Resolution Bandwidth (kHz)	Video Bandwidth (kHz)	Occupied Bandwidth (MHz)
Bottom	6	0	30	100	1.086
Middle	6	0	30	100	1.094
Top	6	0	30	100	1.098

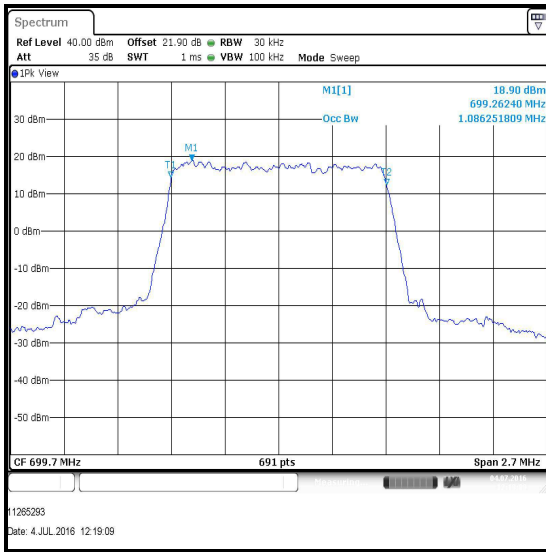

Bottom Channel / 16QAM

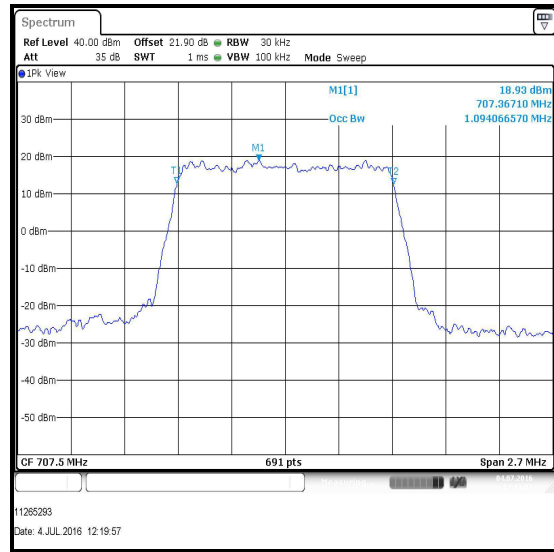

Middle Channel / 16QAM

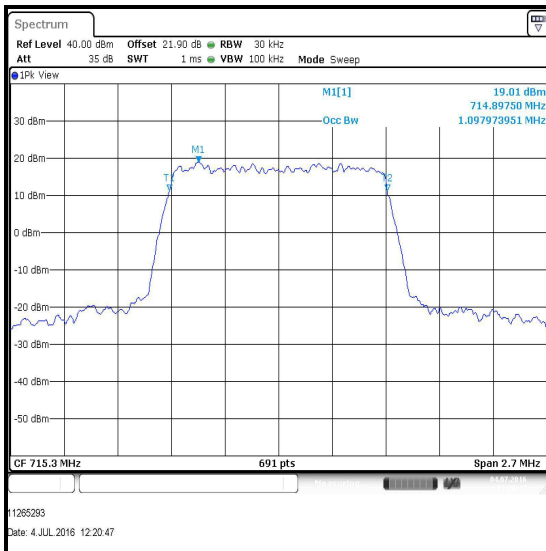

Top Channel / 16QAM

Transmitter Occupied Bandwidth (continued)

Results: 3 MHz Channel Bandwidth / QPSK

Channel	Resource Block(s)	Resource Block Offset	Resolution Bandwidth (kHz)	Video Bandwidth (kHz)	Occupied Bandwidth (MHz)
Bottom	15	0	100	300	2.745
Middle	15	0	100	300	2.745
Top	15	0	100	300	2.745

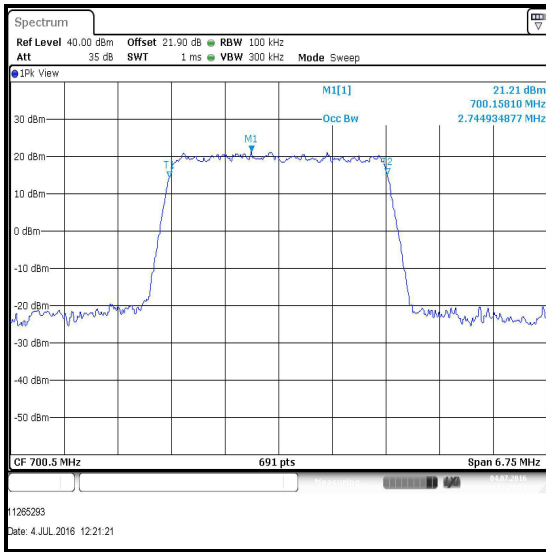

Bottom Channel / QPSK

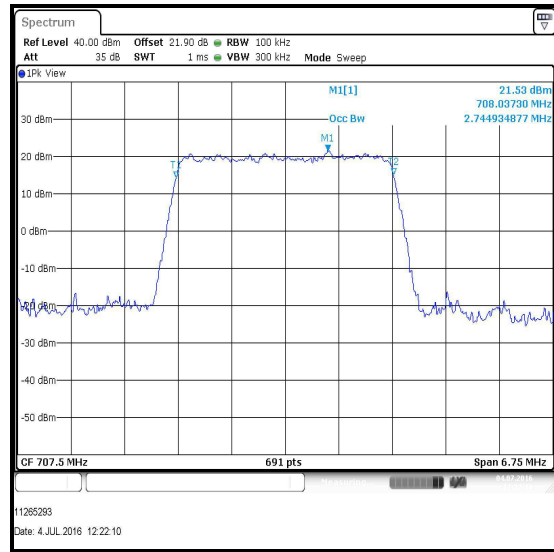

Middle Channel / QPSK

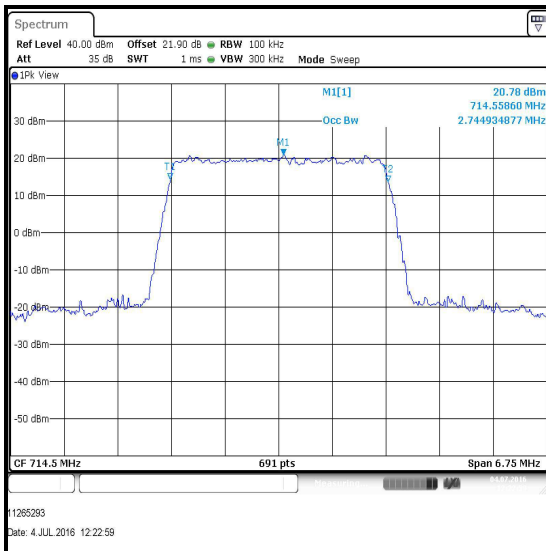

Top Channel / QPSK

Transmitter Occupied Bandwidth (continued)

Results: 3 MHz Channel Bandwidth / 16QAM

Channel	Resource Block(s)	Resource Block Offset	Resolution Bandwidth (kHz)	Video Bandwidth (kHz)	Occupied Bandwidth (MHz)
Bottom	15	0	100	300	2.735
Middle	15	0	100	300	2.725
Top	15	0	100	300	2.745

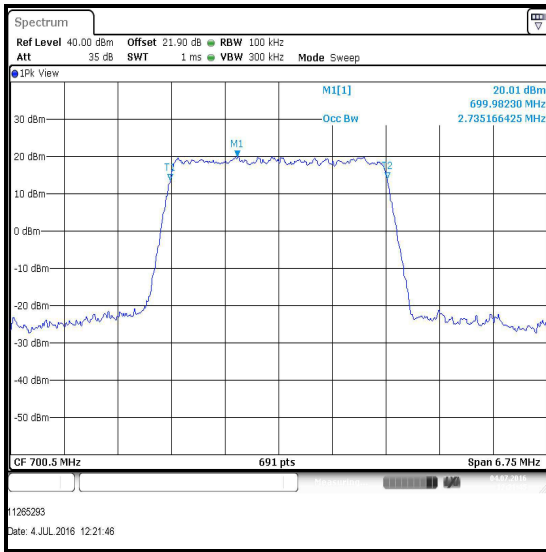

Bottom Channel / 16QAM

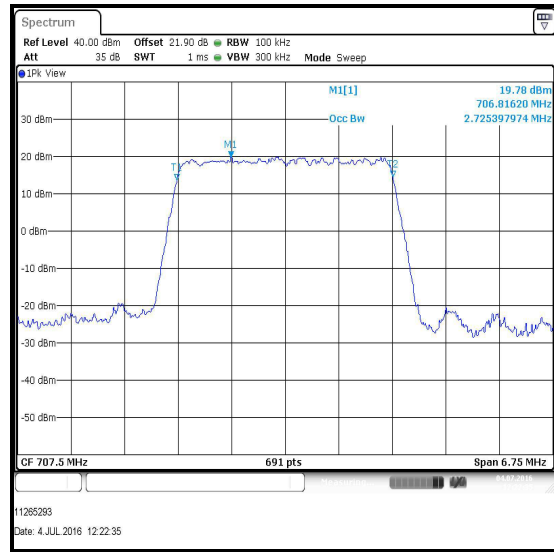

Middle Channel / 16QAM

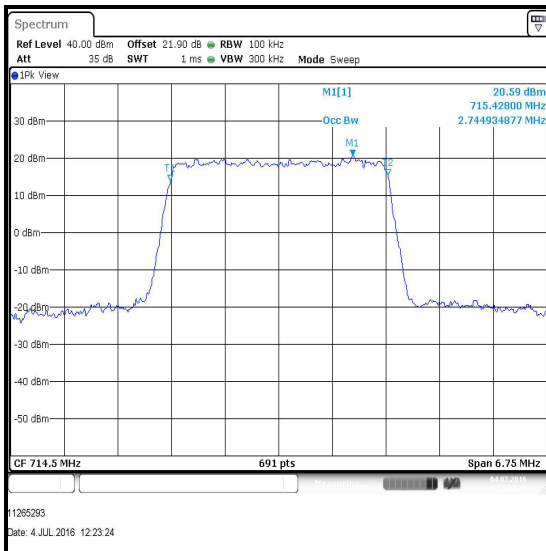

Top Channel / 16QAM

Transmitter Occupied Bandwidth (continued)

Results: 5 MHz Channel Bandwidth / QPSK

Channel	Resource Block(s)	Resource Block Offset	Resolution Bandwidth (kHz)	Video Bandwidth (kHz)	Occupied Bandwidth (MHz)
Bottom	25	0	100	300	4.510
Middle	25	0	100	300	4.526
Top	25	0	100	300	4.559

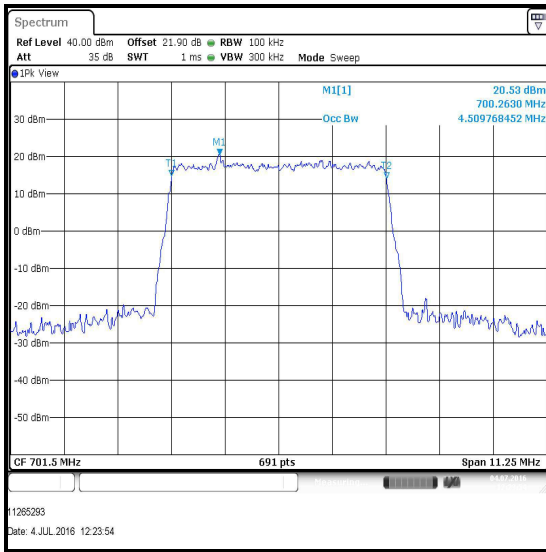

Bottom Channel / QPSK

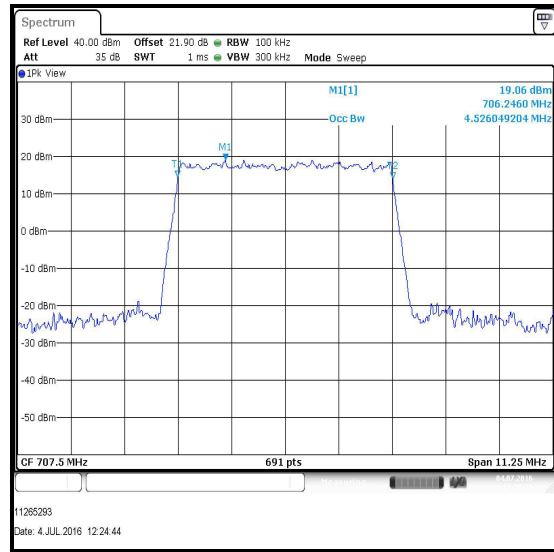

Middle Channel / QPSK

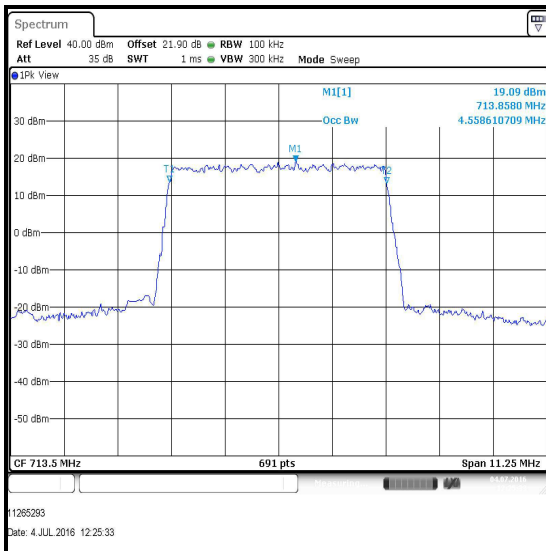

Top Channel / QPSK

Transmitter Occupied Bandwidth (continued)

Results: 5 MHz Channel Bandwidth / 16QAM

Channel	Resource Block(s)	Resource Block Offset	Resolution Bandwidth (kHz)	Video Bandwidth (kHz)	Occupied Bandwidth (MHz)
Bottom	25	0	100	300	4.526
Middle	25	0	100	300	4.493
Top	25	0	100	300	4.510

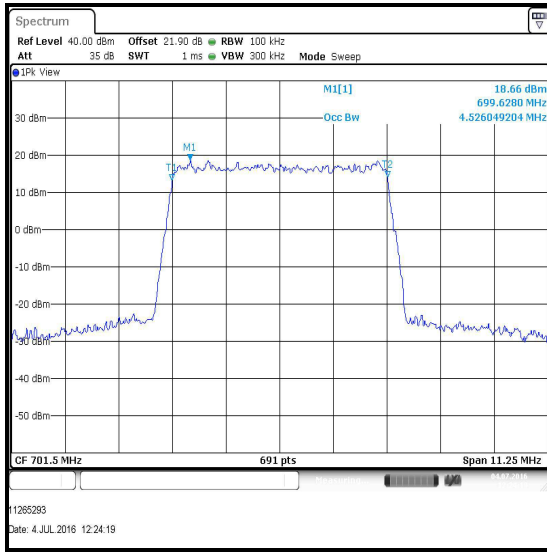

Bottom Channel / 16QAM

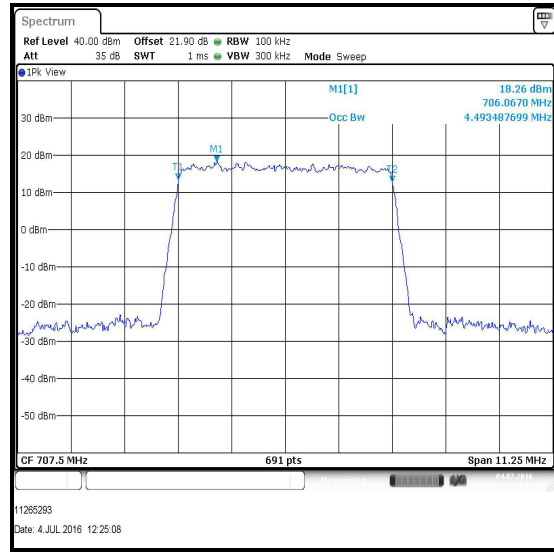

Middle Channel / 16QAM

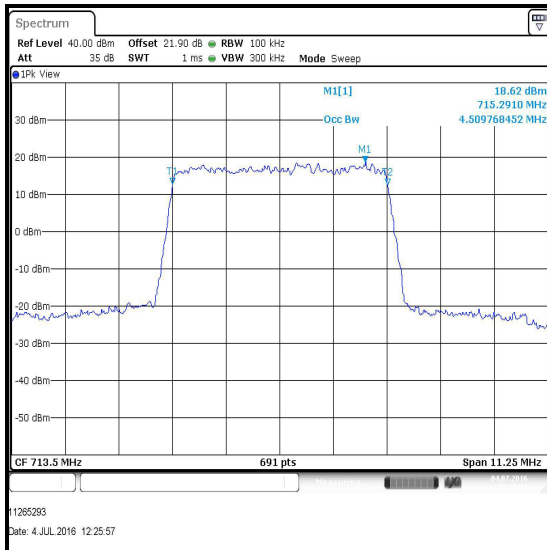

Top Channel / 16QAM

Transmitter Occupied Bandwidth (continued)

Results: 10 MHz Channel Bandwidth / QPSK

Channel	Resource Block(s)	Resource Block Offset	Resolution Bandwidth (kHz)	Video Bandwidth (kHz)	Occupied Bandwidth (MHz)
Bottom	50	0	200	1000	9.020
Middle	50	0	200	1000	8.987
Top	50	0	200	1000	9.020

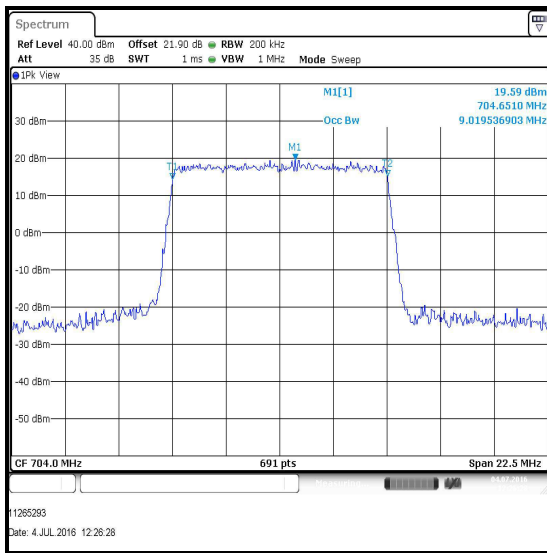

Bottom Channel / QPSK

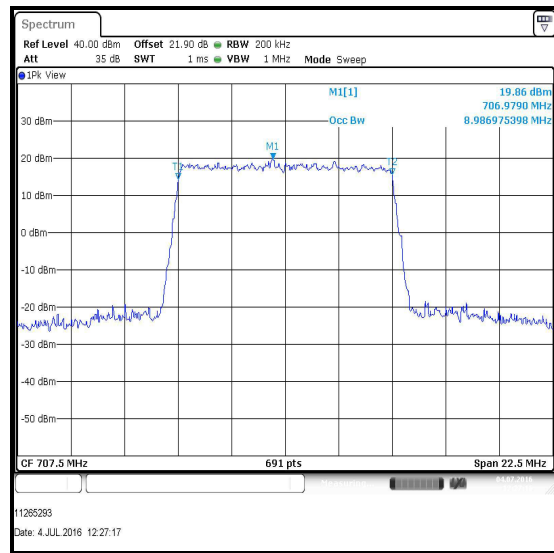

Middle Channel / QPSK

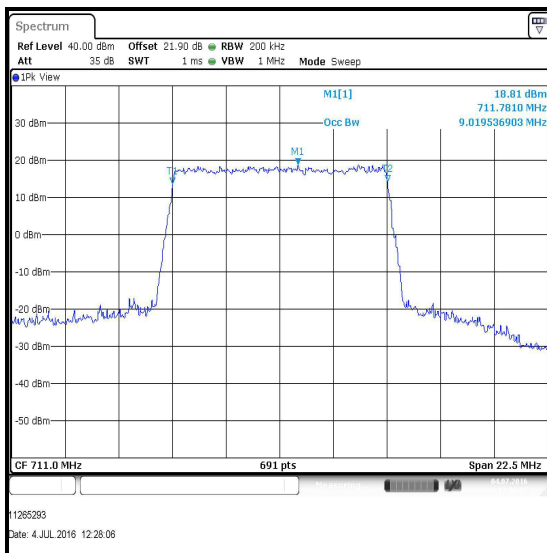

Top Channel / QPSK

Transmitter Occupied Bandwidth (continued)

Results: 10 MHz Channel Bandwidth / 16QAM

Channel	Resource Block(s)	Resource Block Offset	Resolution Bandwidth (kHz)	Video Bandwidth (kHz)	Occupied Bandwidth (MHz)
Bottom	50	0	200	1000	8.987
Middle	50	0	200	1000	8.987
Top	50	0	200	1000	9.020

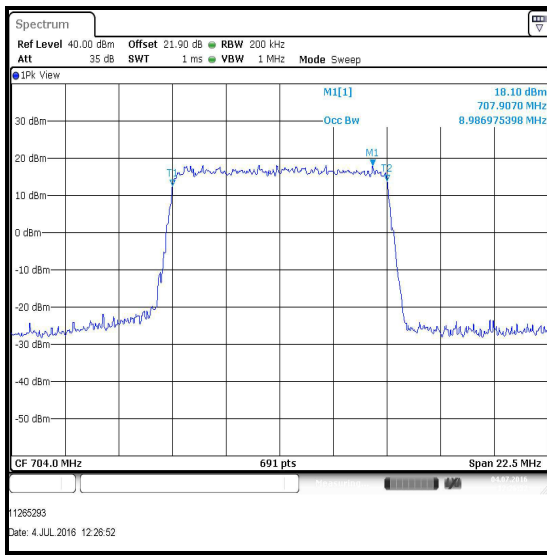

Bottom Channel / 16QAM

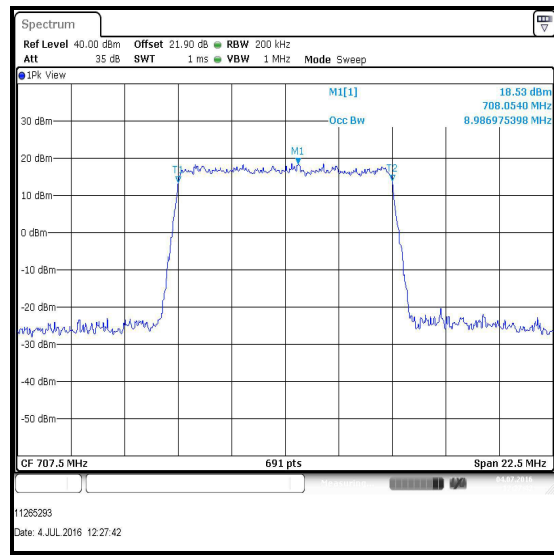

Middle Channel / 16QAM

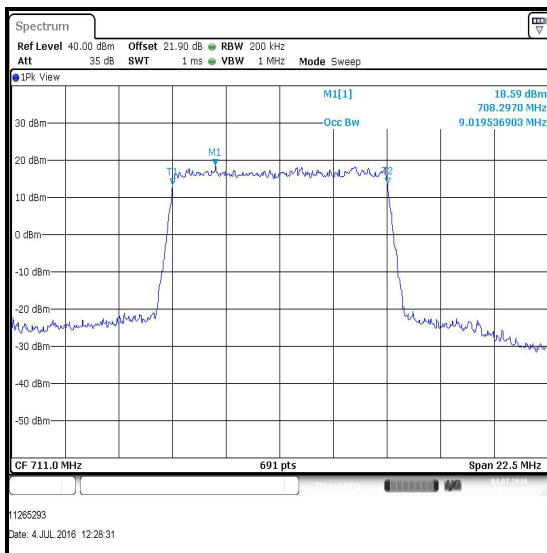

Top Channel / 16QAM

Transmitter Occupied Bandwidth (continued)**Test Equipment Used:**

Asset No.	Instrument	Manufacturer	Type No.	Serial No.	Date Calibration Due	Cal. Interval (Months)
M2002	Thermohygrometer	Testo	608-H1	45041825	02 Apr 2017	12
M1869	Wideband Radio Comms Tester	Rohde & Schwarz	CMW500	145923	05 Apr 2017	12
M1873	Signal Analyser	Rohde & Schwarz	FSV30	103074	27 Jun 2017	12
A2845	Attenuator	Radiall	R411.806.121	24325927	Calibrated before use	-
A2844	Attenuator	Radiall	R411.803.121	23404066	Calibrated before use	-
A2504	Directional Coupler	AtlanTecRF	CDC-003060-10	13122501839	Calibrated before use	-
S0562	Power Supply	Thurlby Thandar	PL330QMD	054895	Calibrated before use	-
M1269	Multimeter	Fluke	179	90250210	13 May 2017	12
G0628	Signal Generator	Rohde & Schwarz	SMBV100A	261847	25 Jan 2017	12
M1835	Signal Analyser	Rohde & Schwarz	FSV30	103050	26 Feb 2017	12

5.2.4. Transmitter Radiated Spurious Emissions – LAT**Test Summary:**

Test Engineers:	Nigel Davison & Andrew Edwards	Test Dates:	12 July 2016 & 17 July 2016
Test Sample IMEI:	358640070087482		

FCC Reference:	Parts 2.1053 & 27.53(g)
Test Method Used:	KDB 971168 Section 6.1 referencing FCC Part 2.1053
Frequency Range:	30 MHz to 8 GHz
Configuration:	10 MHz, QPSK, 1RB, 0 Offset

Environmental Conditions:

Temperature (°C):	23 to 25
Relative Humidity (%):	38 to 46

Note(s):

1. The EUT was set to transmit with a 10 MHz channel bandwidth with QPSK modulation applied and 1 resource block with 0 offset, as this was found to be the worst case modulation scheme with regards to emissions after preliminary investigations and was therefore deemed to be the worst case.
2. The emission seen on the 30 MHz to 1 GHz plot at approximately 707.5 MHz is the EUT carrier.
3. No spurious emissions were detected above the measurement system noise floor therefore the highest peak noise floor reading of the measuring receiver was recorded in the table below.
4. Middle channel results are recorded in this report and are representative of bottom and top channel results which are held on the UL IT server and available for inspection on request.
5. Pre-scan measurements below 1 GHz are performed on separate plots with different transducer factors for vertical and horizontal polarisation. The pre-scan plot for 30 MHz to 1 GHz in this test report is for vertical only. All other plots are stored on the company server and are available if required.
6. Measurements below 1 GHz were performed in a semi-anechoic chamber (Asset Number K0017) at a distance of 3 metres. The EUT was placed at a height of 80 cm above the reference ground plane in the centre of the chamber turntable. Maximum emission levels were determined by height searching the measurement antenna over the range 1 metre to 4 metres.
7. Pre-scans above 1 GHz were performed in a semi-anechoic chamber (Asset Number K0017) at a distance of 3 metres. The EUT was placed at a height of 1.5 metres above the test chamber floor in the centre of the chamber turntable. Maximum emission levels were determined by height searching the measurement antenna over the range 1 metre to 4 metres.
8. Radiated spurious emission testing between 150 kHz and 30 MHz was performed for support of the NFC test report. No spurious emissions were observed above the noise floor of the measurement system.

Transmitter Radiated Spurious Emissions – LAT (continued)

Test setup for radiated measurements:

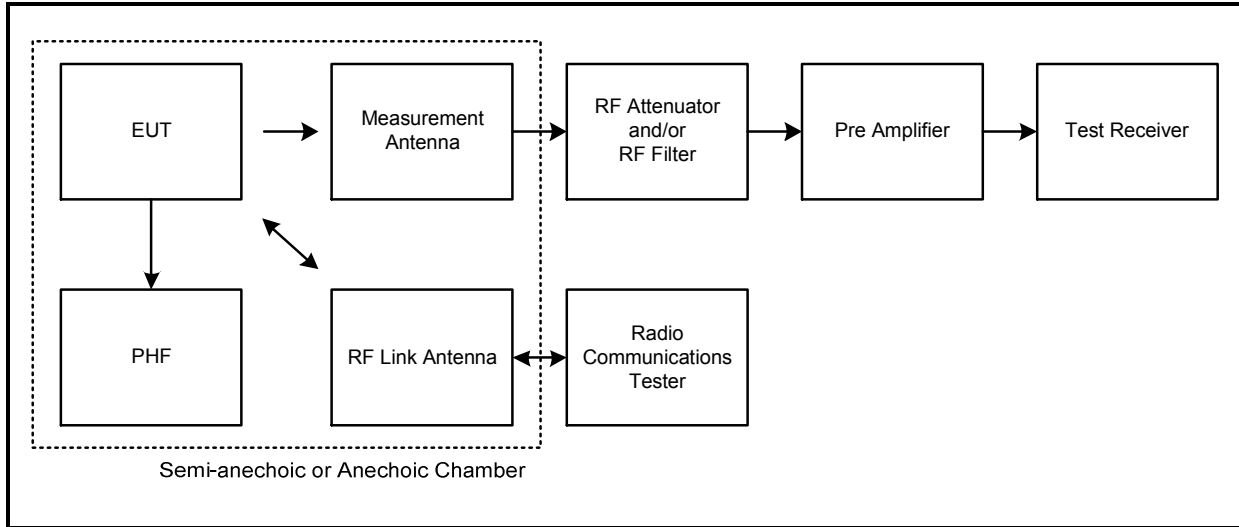

Results: Middle Channel

Frequency (MHz)	Peak Level (dBm)	Limit (dBm)	Margin (dB)	Result
992.228	-32.6	-13.0	19.6	Complied

Transmitter Radiated Spurious Emissions – LAT (continued)

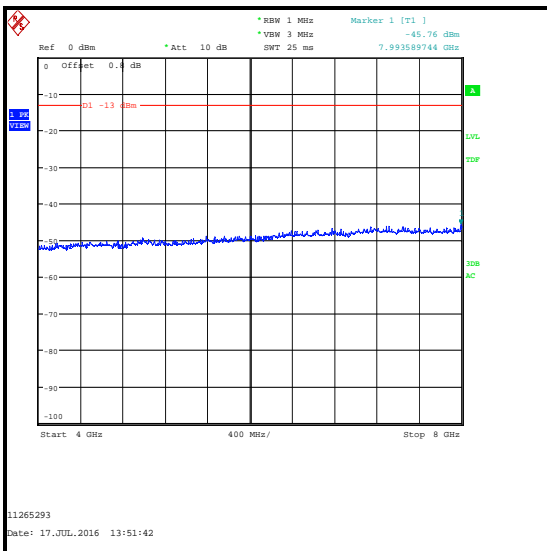
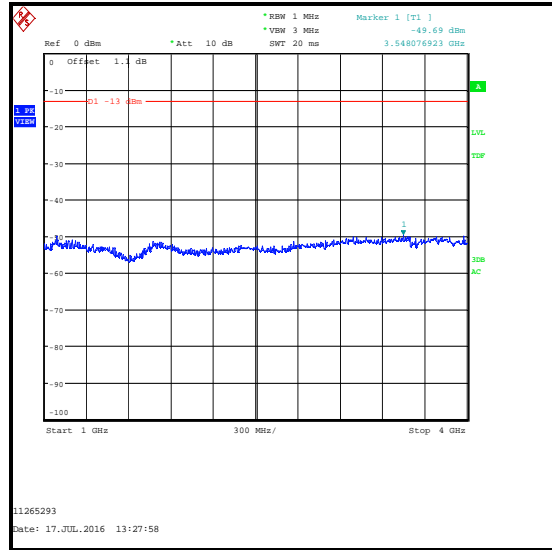
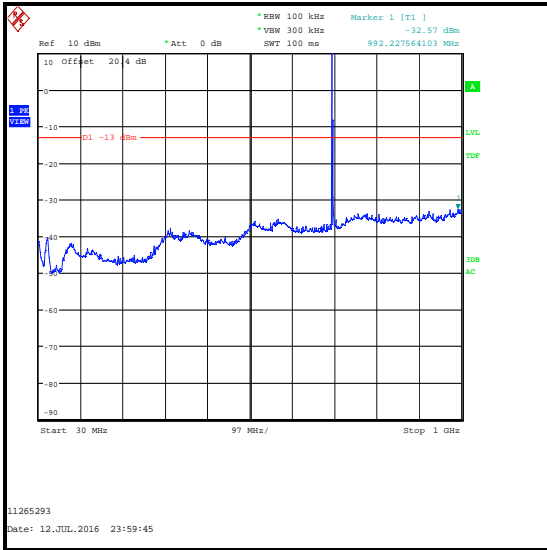

Transmitter Radiated Spurious Emissions – LAT (continued)**Test Equipment Used:**

Asset No.	Instrument	Manufacturer	Type No.	Serial No.	Date Calibration Due	Cal. Interval (Months)
M2003	Thermohygrometer	Testo	608-H1	45046641	22 Apr 2017	12
K0017	3m RSE Chamber	Rainford EMC	N/A	N/A	17 May 2017	12
M1995	Test Receiver	Rohde & Schwarz	ESU40	100428	21 Mar 2017	12
A2888	Antenna	Schwarzbeck	VULB 9163	9163-941	07 Apr 2017	12
A2889	Antenna	Schwarzbeck	BBHA 9120 B	BBHA 9120 B 653	07 Apr 2017	12
A2863	Pre-Amplifier	Agilent	8449B	3008A02100	07 Jan 2017	12
A2918	Attenuator	AtlanTecRF	AN18W5-20	832828#1	19 May 2017	12
A2908	High Pass Filter	Wainwright	WHJE5-920-1000-4000-60EE	3	23 May 2017	12
A2914	High Pass Filter	AtlanTecRF	AFH-03000	2155	19 May 2017	12
A2947	High Pass Filter	AtlanTecRF	AFH-07000	1601900001	01 May 2017	12

5.2.5. Transmitter Radiated Spurious Emissions – UAT**Test Summary:**

Test Engineers:	Nigel Davison & Andrew Edwards	Test Dates:	12 July 2016 & 15 July 2016
Test Sample IMEI:	358640070309175		

FCC Reference:	Parts 2.1053 & 27.53(g)
Test Method Used:	KDB 971168 Section 6.1 referencing FCC Part 2.1053
Frequency Range:	30 MHz to 8 GHz
Configuration:	10 MHz, QPSK, 1RB, 0 Offset

Environmental Conditions:

Temperature (°C):	23 to 25
Relative Humidity (%):	38 to 46

Note(s):

1. The EUT was set to transmit with a 10 MHz channel bandwidth with QPSK modulation applied and 1 resource block with 0 offset, as this was found to be the worst case modulation scheme with regards to emissions after preliminary investigations and was therefore deemed to be the worst case.
2. The emission seen on the 30 MHz to 1 GHz plot at approximately 707.5 MHz is the EUT carrier.
3. No spurious emissions were detected above the measurement system noise floor therefore the highest peak noise floor reading of the measuring receiver was recorded in the table below.
4. Middle channel results are recorded in this report and are representative of bottom and top channel results which are held on the UL IT server and available for inspection on request.
5. Pre-scan measurements below 1 GHz are performed on separate plots with different transducer factors for vertical and horizontal polarisation. The pre-scan plot for 30 MHz to 1 GHz in this test report is for vertical only. All other plots are stored on the company server and are available if required.
6. Measurements below 1 GHz were performed in a semi-anechoic chamber (Asset Number K0017) at a distance of 3 metres. The EUT was placed at a height of 80 cm above the reference ground plane in the centre of the chamber turntable. Maximum emission levels were determined by height searching the measurement antenna over the range 1 metre to 4 metres.
7. Pre-scans above 1 GHz were performed in a semi-anechoic chamber (Asset Number K0017) at a distance of 3 metres. The EUT was placed at a height of 1.5 metres above the test chamber floor in the centre of the chamber turntable. Maximum emission levels were determined by height searching the measurement antenna over the range 1 metre to 4 metres.
8. Radiated spurious emission testing between 150 kHz and 30 MHz was performed for support of the NFC test report. No spurious emissions were observed above the noise floor of the measurement system.

Results: Middle Channel

Frequency (MHz)	Peak Level (dBm)	Limit (dBm)	Margin (dB)	Result
1000.000	-32.8	-13.0	19.8	Complied

Transmitter Radiated Spurious Emissions – UAT (continued)

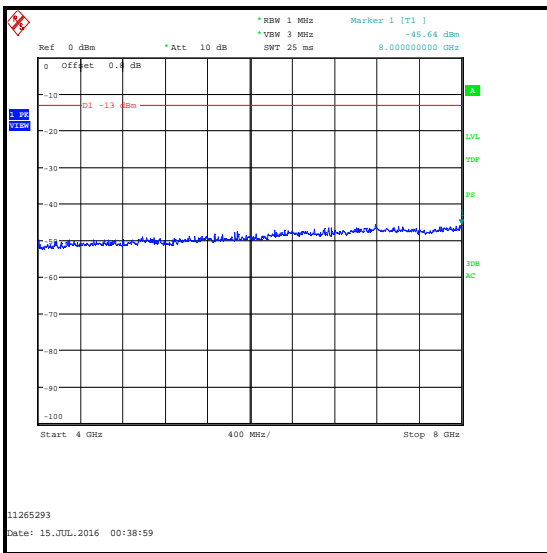
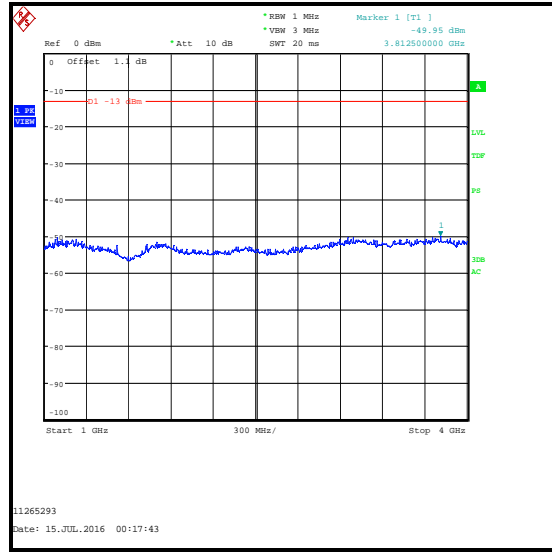
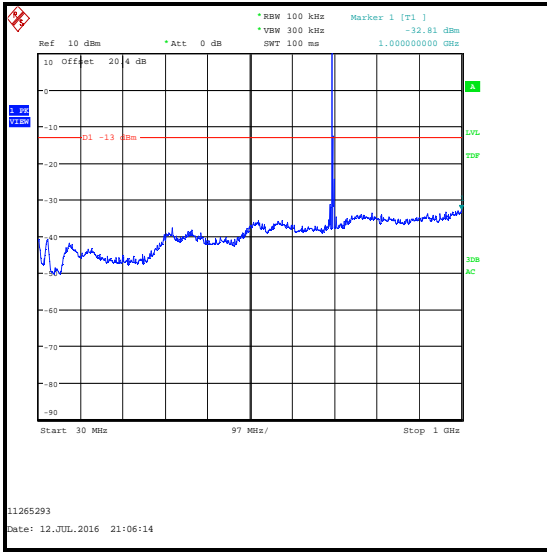

Transmitter Radiated Spurious Emissions – UAT (continued)**Test Equipment Used:**

Asset No.	Instrument	Manufacturer	Type No.	Serial No.	Date Calibration Due	Cal. Interval (Months)
M2003	Thermohygrometer	Testo	608-H1	45046641	22 Apr 2017	12
K0017	3m RSE Chamber	Rainford EMC	N/A	N/A	17 May 2017	12
M1995	Test Receiver	Rohde & Schwarz	ESU40	100428	21 Mar 2017	12
A2888	Antenna	Schwarzbeck	VULB 9163	9163-941	07 Apr 2017	12
A2889	Antenna	Schwarzbeck	BBHA 9120 B	BBHA 9120 B 653	07 Apr 2017	12
A2863	Pre-Amplifier	Agilent	8449B	3008A02100	07 Jan 2017	12
A2918	Attenuator	AtlanTecRF	AN18W5-20	832828#1	19 May 2017	12
A2908	High Pass Filter	Wainwright	WHJE5-920-1000-4000-60EE	3	23 May 2017	12
A2914	High Pass Filter	AtlanTecRF	AFH-03000	2155	19 May 2017	12
A2947	High Pass Filter	AtlanTecRF	AFH-07000	1601900001	01 May 2017	12

5.2.6. Transmitter Radiated Emissions at Band Edges - LAT**Test Summary:**

Test Engineer:	Andrew Edwards	Test Date:	12 July 2016
Test Sample IMEI:	358640070286456		

FCC Reference:	Parts 2.1053 & 27.53(g)
Test Method Used:	KDB 971168 Section 6.1 referencing FCC Part 27.53

Environmental Conditions:

Temperature (°C):	25
Relative Humidity (%):	44

Note(s):

1. Measurements were performed with the EUT transmitting QPSK and 16QAM modulation schemes, with the maximum resource blocks settings.
2. Measurements were performed in a semi anechoic chamber (Asset Number K0017) at a distance of 3 metres. The EUT was placed at a height of 80 cm above the reference ground plane in the centre of the chamber turntable. Maximum emission levels were determined by height searching the measurement antenna over the range 1 metre to 4 metres. In the first 1.0 MHz immediately outside and adjacent to the band, the test receiver resolution bandwidth was set to 100 kHz and the video bandwidth was set to 300 kHz. Sweep time was set to auto and an RMS detector with trace averaging of at least 100 sweeps was used.
3. * In accordance with FCC Part 27.53 (g); a relaxed resolution bandwidth of 30 kHz may be employed for the first 100 kHz immediately outside and adjacent to the licensee's frequency block.

Transmitter Radiated Emissions at Band Edges (continued) - LAT

Results: 1.4 MHz Channel Bandwidth / QPSK

Frequency (MHz)	Resource Block(s)	Resource Block Offset	Emission Level (dBm)	Limit (dBm)	Margin (dB)	Result
699	6	0	-20.6	-13.0	7.6	Complied
716	6	0	-21.6	-13.0	8.6	Complied

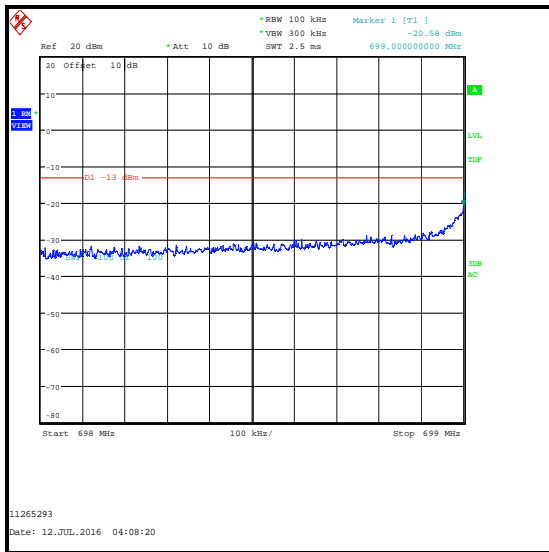

QPSK / Lower Band Edge

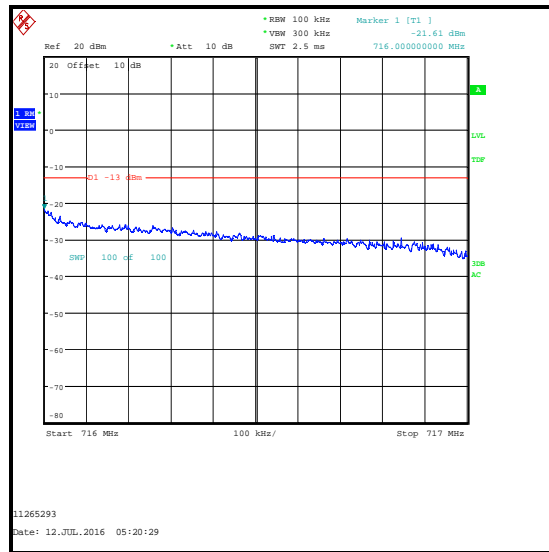

QPSK / Upper Band Edge

Transmitter Radiated Emissions at Band Edges (continued) - LAT

Results: 1.4 MHz Channel Bandwidth / QPSK

Frequency (MHz)	Resource Block(s)	Resource Block Offset	Emission Level (dBm)	Limit (dBm)	Margin (dB)	Result
699	1	0	-14.7	-13.0	1.7	Complied
716	1	5	-25.1	-13.0	12.1	Complied
716.002	1	5	-25.0	-13.0	12.0	Complied
699	1	5	-35.4	-13.0	22.4	Complied
716	1	0	-37.7	-13.0	24.7	Complied

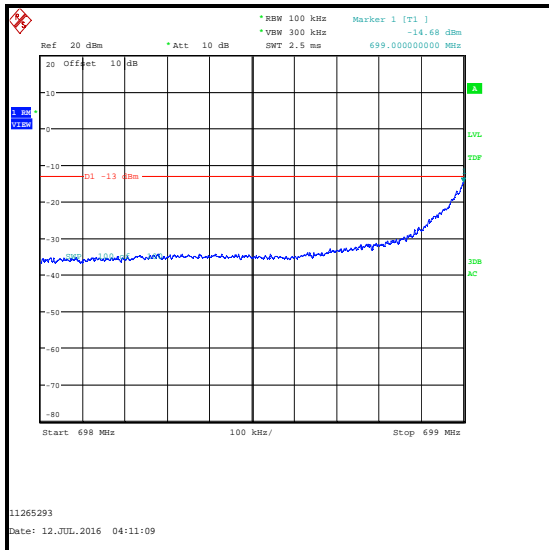

QPSK / 1 RB 0 offset / Lower Band Edge

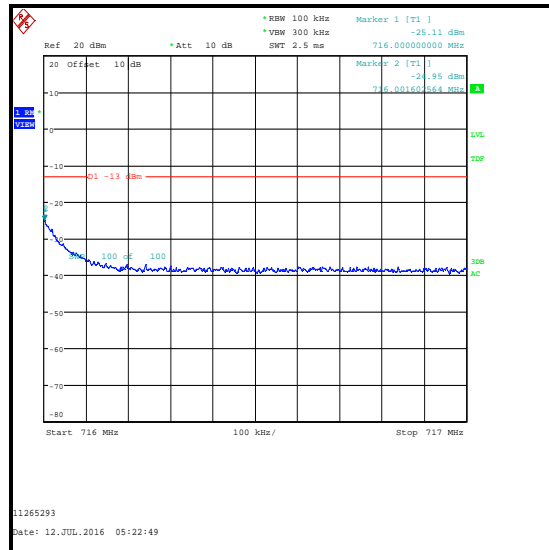

QPSK / 1 RB 5 offset / Upper Band Edge

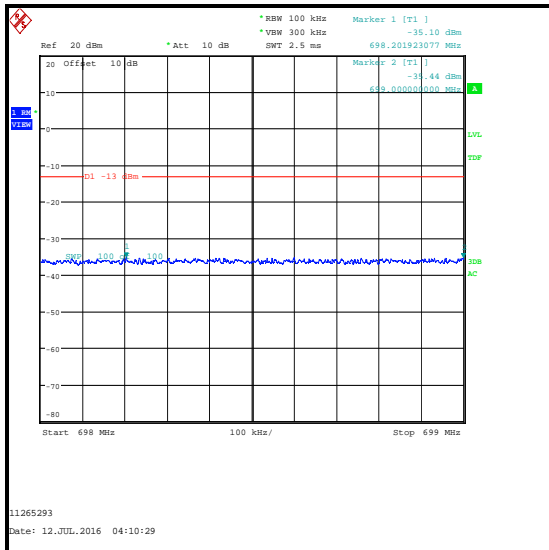

QPSK / 1 RB 5 offset / Lower Band Edge

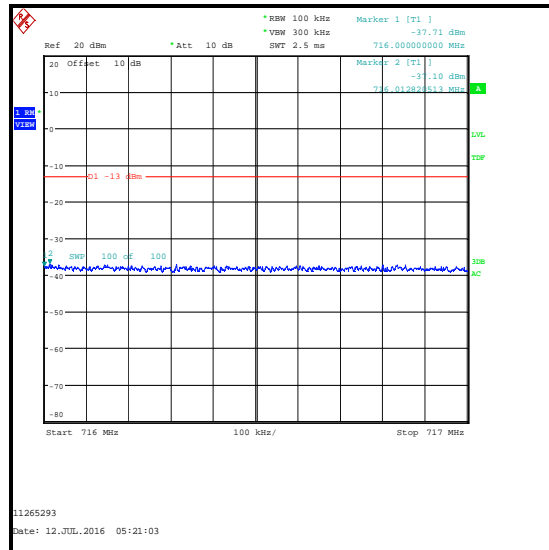

QPSK / 1 RB 0 offset / Upper Band Edge

Transmitter Radiated Emissions at Band Edges (continued) - LAT

Results: 1.4 MHz Channel Bandwidth / 16QAM

Frequency (MHz)	Resource Block(s)	Resource Block Offset	Emission Level (dBm)	Limit (dBm)	Margin (dB)	Result
699	6	0	-21.4	-13.0	8.4	Complied
716	6	0	-23.1	-13.0	10.1	Complied
716.003	6	0	-22.6	-13.0	9.6	Complied

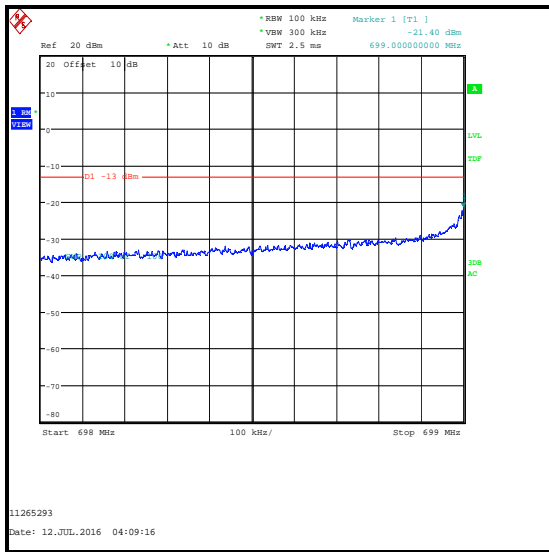

16QAM / Lower Band Edge

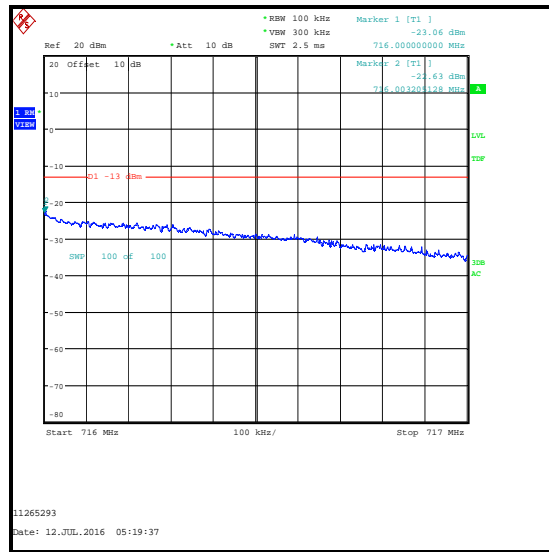

16QAM / Upper Band Edge

Transmitter Radiated Emissions at Band Edges (continued) - LAT

Results: 1.4 MHz Channel Bandwidth / 16QAM

Frequency (MHz)	Resource Block(s)	Resource Block Offset	Emission Level (dBm)	Limit (dBm)	Margin (dB)	Result
698.998	1	0	-13.9	-13.0	0.9	Complied
699	1	0	-14.0	-13.0	1.0	Complied
716	1	5	-25.5	-13.0	12.5	Complied
699	1	5	-35.6	-13.0	22.6	Complied
716	1	0	-37.0	-13.0	24.0	Complied

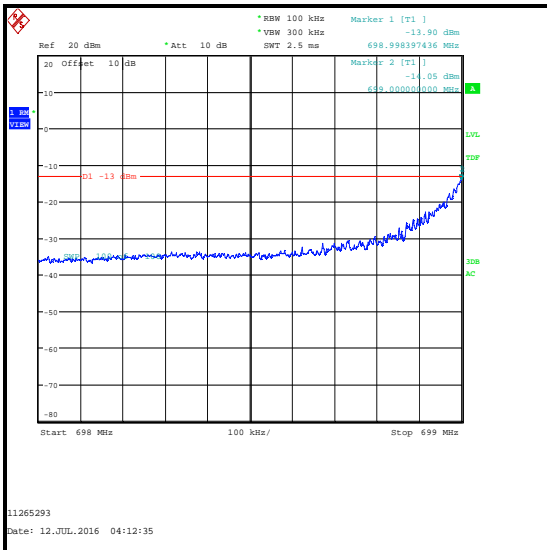

16QAM / 1 RB 0 offset / Lower Band Edge

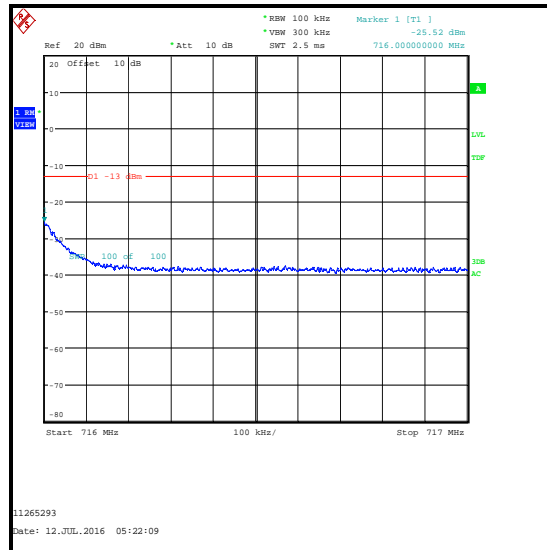

16QAM / 1 RB 5 offset / Upper Band Edge

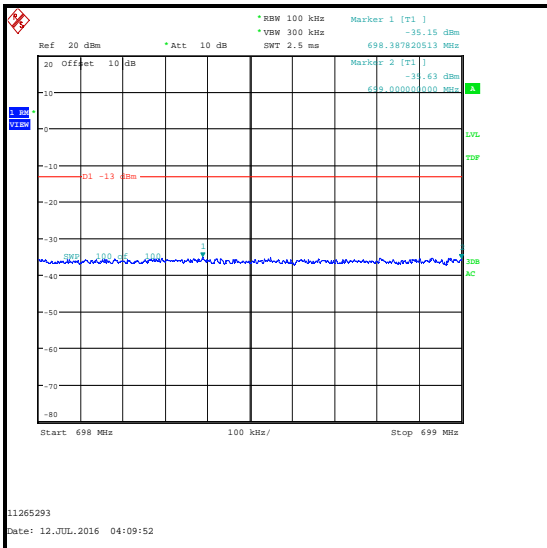

16QAM / 1 RB 5 offset / Lower Band Edge

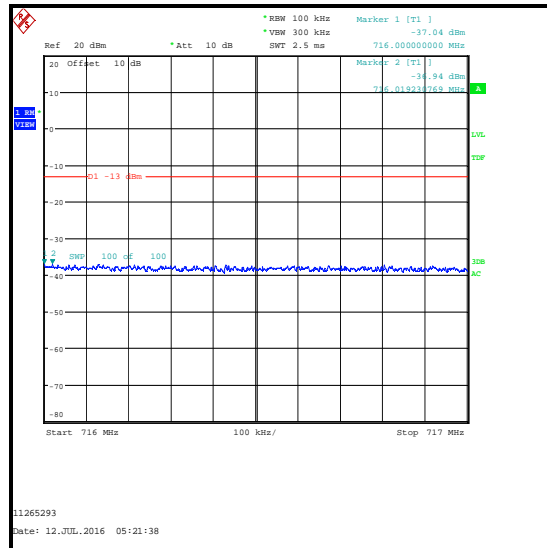

16QAM / 1 RB 0 offset / Upper Band Edge

Transmitter Radiated Emissions at Band Edges (continued) - LAT

Results: 3 MHz Channel Bandwidth / QPSK

Frequency (MHz)	Resource Block(s)	Resource Block Offset	Emission Level (dBm)	Limit (dBm)	Margin (dB)	Result
698.987	15	0	-18.1	-13.0	5.1	Complied
699	15	0	-20.3	-13.0	7.3	Complied
716	15	0	-20.4	-13.0	7.4	Complied
716.003	15	0	-20.1	-13.0	7.1	Complied

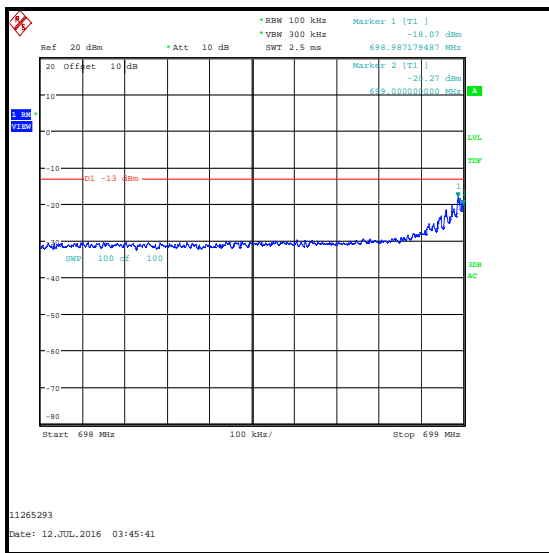

QPSK / Lower Band Edge

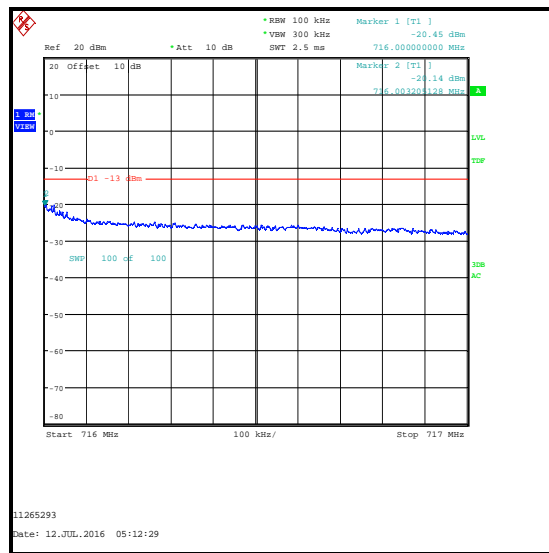

QPSK / Upper Band Edge

Transmitter Radiated Emissions at Band Edges (continued) - LAT

Results: 3 MHz Channel Bandwidth / QPSK

Frequency (MHz)	Resource Block(s)	Resource Block Offset	Emission Level (dBm)	Limit (dBm)	Margin (dB)	Result
698.900	1	0	-23.5	-13.0	10.5	Complied
698.998	1	0	-19.0*	-13.0	6.0	Complied
716	1	14	-21.4*	-13.0	8.4	Complied
716.003	1	14	-20.9*	-13.0	7.9	Complied
716.104	1	14	-25.4	-13.0	12.4	Complied
699	1	14	-36.5	-13.0	23.5	Complied
716	1	0	-38.2	-13.0	25.2	Complied

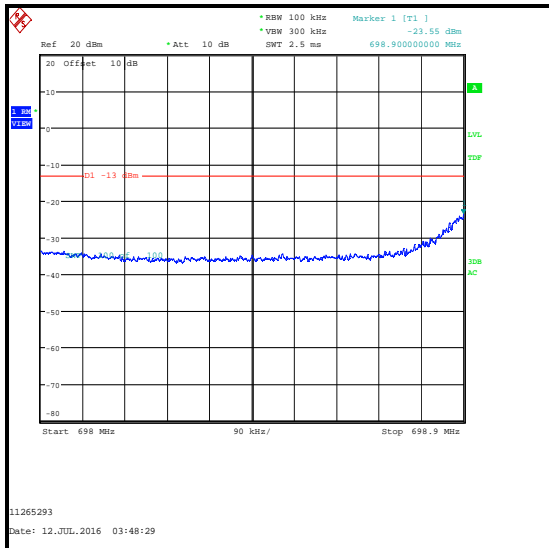

QPSK / 1 RB 0 offset / Lower Band Edge / 689 MHz to 689.9 MHz

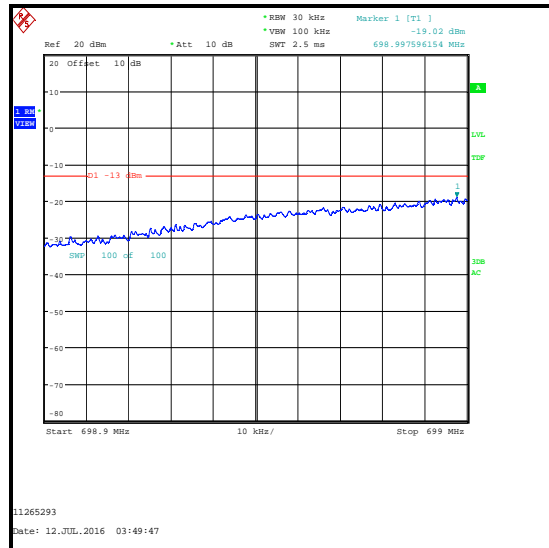

QPSK / 1 RB 0 offset / Lower Band Edge / 689.9 MHz to 699 MHz

Transmitter Radiated Emissions at Band Edges (continued) - LAT

Results: 3 MHz Channel Bandwidth / QPSK

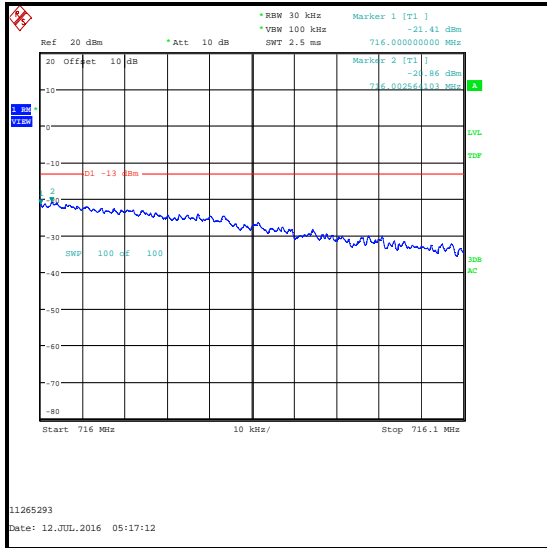

QPSK / 1 RB 14 offset / Upper Band Edge / 716 MHz to 716.1 MHz

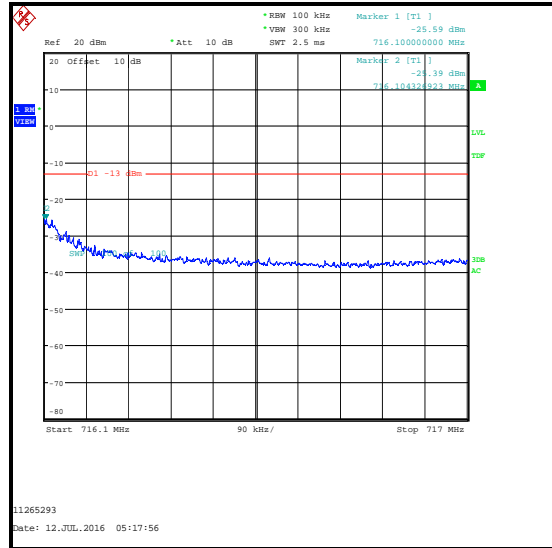

QPSK / 1 RB 14 offset / Upper Band Edge / 716.1 MHz to 717 MHz

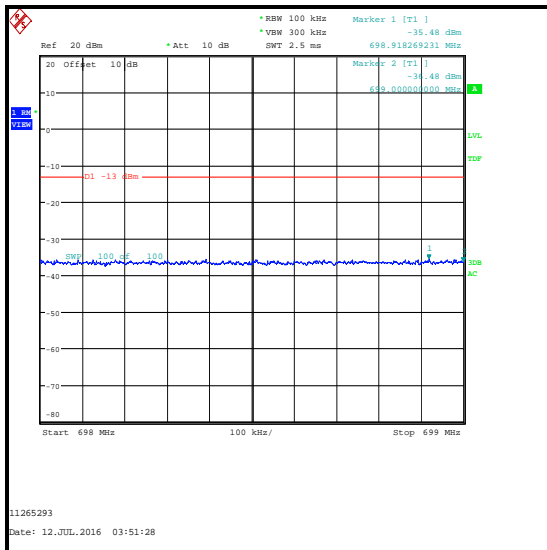

QPSK / 1 RB 14 offset / Lower Band Edge

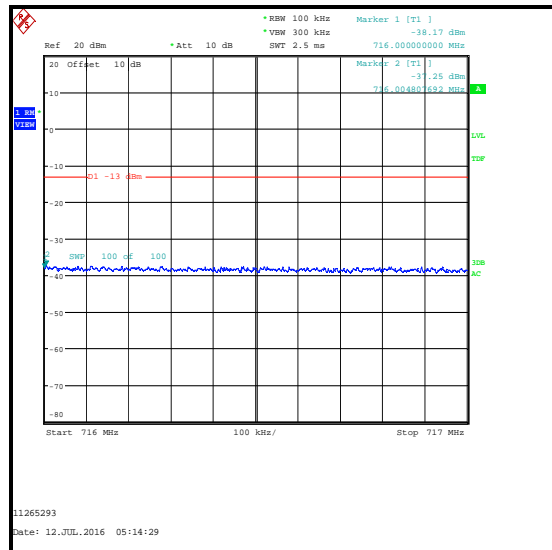

QPSK / 1 RB 0 offset / Upper Band Edge

Transmitter Radiated Emissions at Band Edges (continued) - LAT

Results: 3 MHz Channel Bandwidth / 16QAM

Frequency (MHz)	Resource Block(s)	Resource Block Offset	Emission Level (dBm)	Limit (dBm)	Margin (dB)	Result
698.997	15	0	-21.1	-13.0	8.1	Complied
699	15	0	-21.9	-13.0	8.9	Complied
716	15	0	-19.9	-13.0	6.9	Complied
716.002	15	0	-19.7	-13.0	6.7	Complied

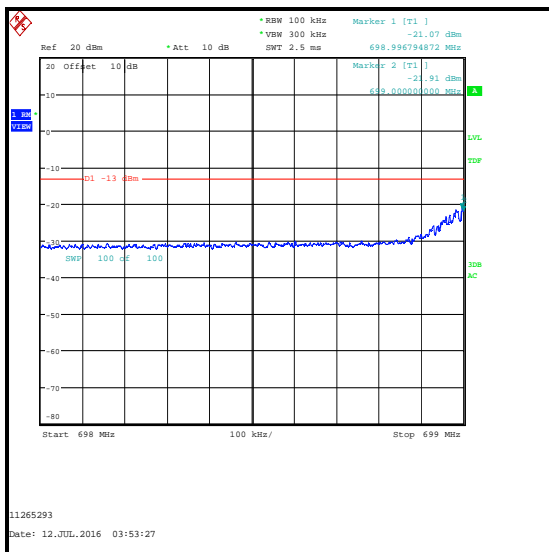

16QAM / Lower Band Edge

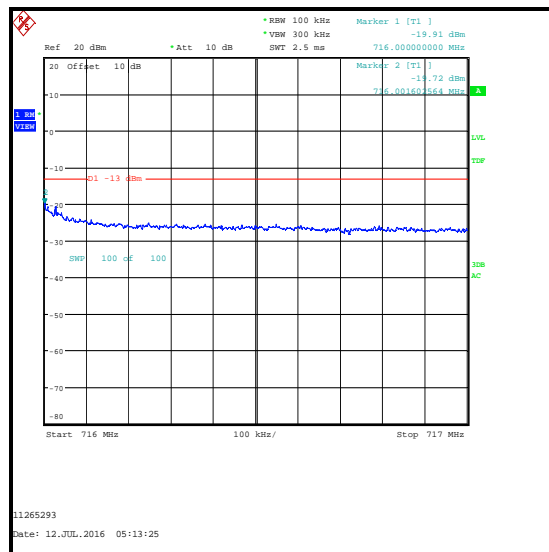

16QAM / Upper Band Edge

Transmitter Radiated Emissions at Band Edges (continued) - LAT

Results: 3 MHz Channel Bandwidth / 16QAM

Frequency (MHz)	Resource Block(s)	Resource Block Offset	Emission Level (dBm)	Limit (dBm)	Margin (dB)	Result
698.900	1	0	-21.0	-13.0	8.0	Complied
698.998	1	0	-18.2*	-13.0	5.2	Complied
699	1	0	-19.5*	-13.0	6.5	Complied
716	1	14	-20.6*	-13.0	7.6	Complied
716.001	1	14	-20.5*	-13.0	7.5	Complied
716.100	1	14	-24.0	-13.0	11.0	Complied
699	1	14	-36.0	-13.0	23.0	Complied
716	1	0	-38.7	-13.0	25.7	Complied

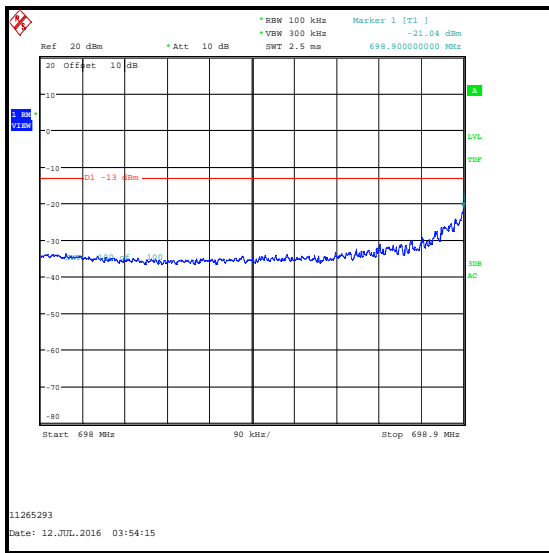

16QAM / 1 RB 0 offset / Lower Band Edge / 689 MHz to 698.9 MHz

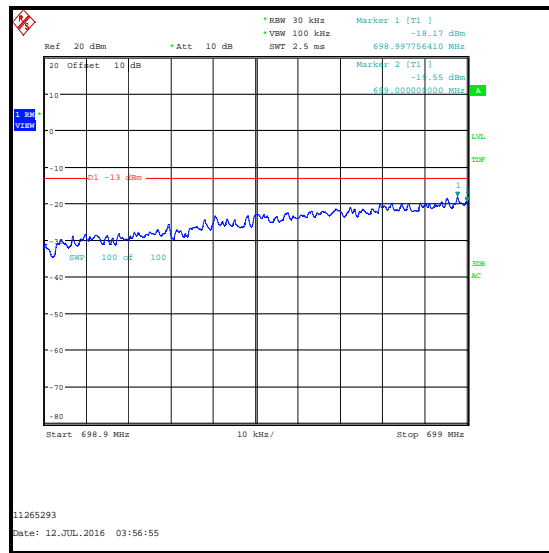

16QAM / 1 RB 0 offset / Lower Band Edge / 689.9 MHz to 699 MHz

Transmitter Radiated Emissions at Band Edges (continued) - LAT

Results: 3 MHz Channel Bandwidth / 16QAM

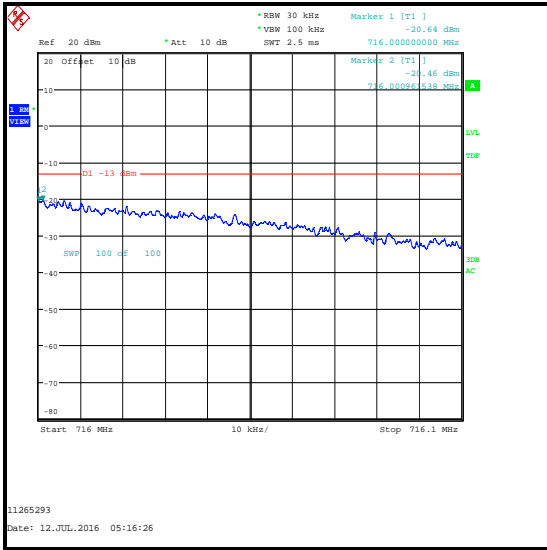

16QAM / 1 RB 14 offset / Upper Band Edge / 716 MHz to 716.1 MHz

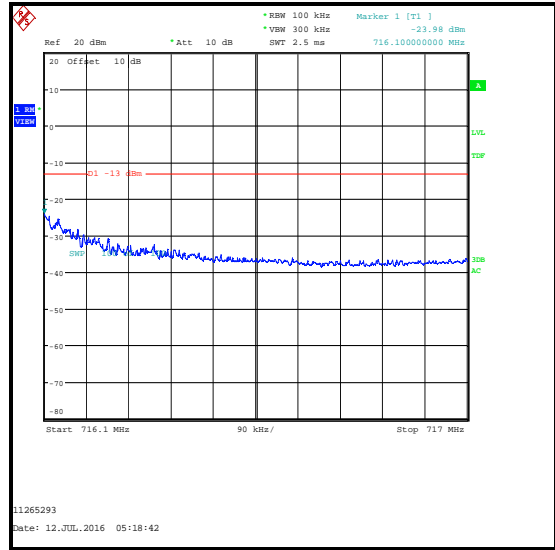

16QAM / 1 RB 14 offset / Upper Band Edge / 716.1 MHz to 717 MHz

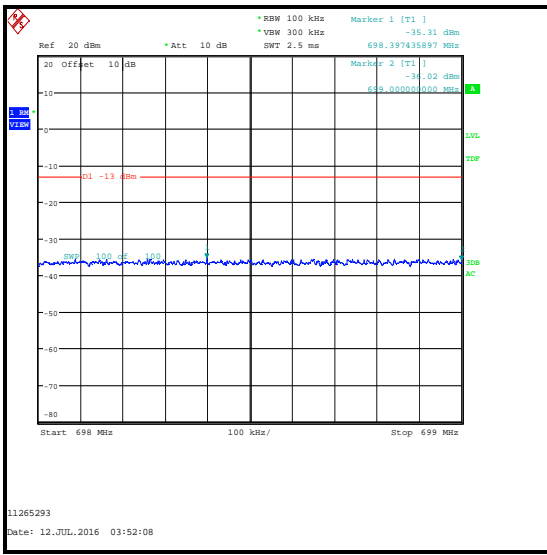

16QAM / 1 RB 14 offset / Lower Band Edge

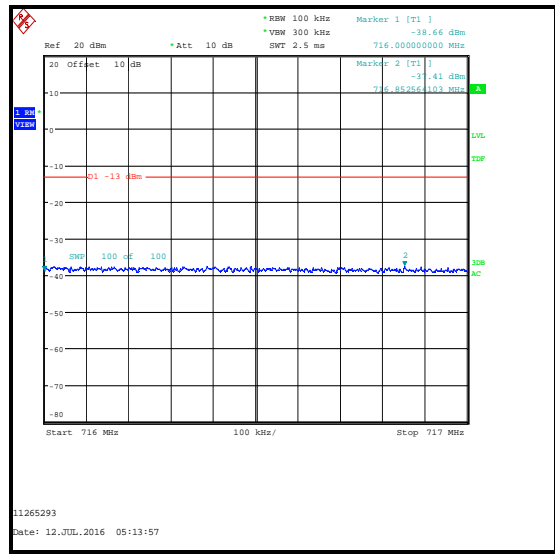

16QAM / 1 RB 0 offset / Upper Band Edge

Transmitter Radiated Emissions at Band Edges (continued) - LAT

Results: 5 MHz Channel Bandwidth / QPSK

Frequency (MHz)	Resource Block(s)	Resource Block Offset	Emission Level (dBm)	Limit (dBm)	Margin (dB)	Result
698.981	25	0	-24.0	-13.0	11.0	Complied
699	25	0	-24.9	-13.0	11.9	Complied
716	25	0	-25.6	-13.0	12.6	Complied
716.018	25	0	-24.9	-13.0	11.9	Complied

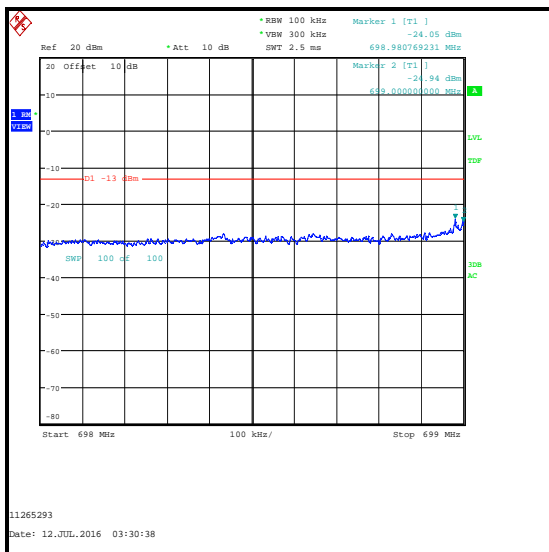

QPSK / Lower Band Edge

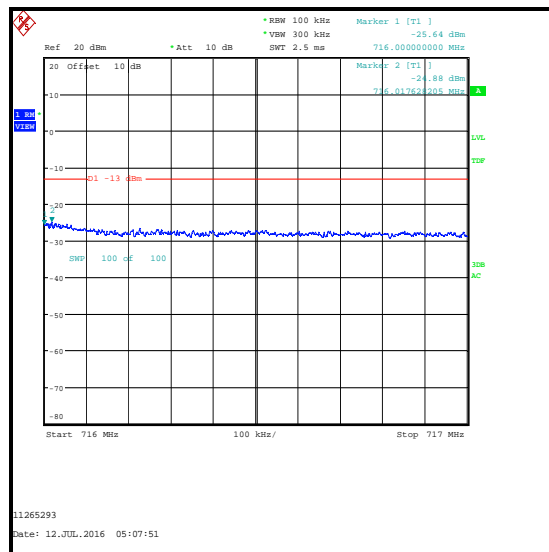

QPSK / Upper Band Edge

Transmitter Radiated Emissions at Band Edges (continued) - LAT

Results: 5 MHz Channel Bandwidth / QPSK

Frequency (MHz)	Resource Block(s)	Resource Block Offset	Emission Level (dBm)	Limit (dBm)	Margin (dB)	Result
699	1	0	-17.4	-13.0	4.4	Complied
716	1	24	-23.0	-13.0	10.0	Complied
716.011	1	24	-20.2	-13.0	7.2	Complied
699	1	24	-36.5	-13.0	23.5	Complied
716	1	0	-38.8	-13.0	25.8	Complied

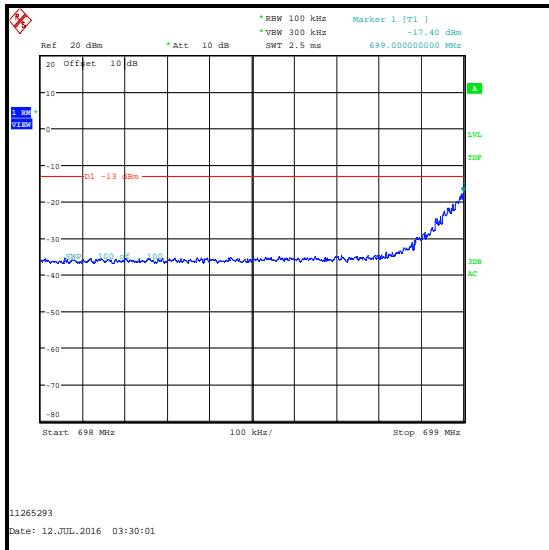

QPSK / 1 RB 0 offset / Lower Band Edge

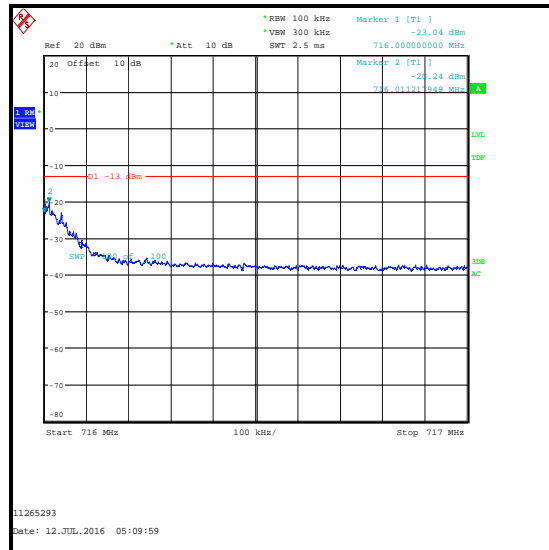

QPSK / 1 RB 24 offset / Upper Band Edge

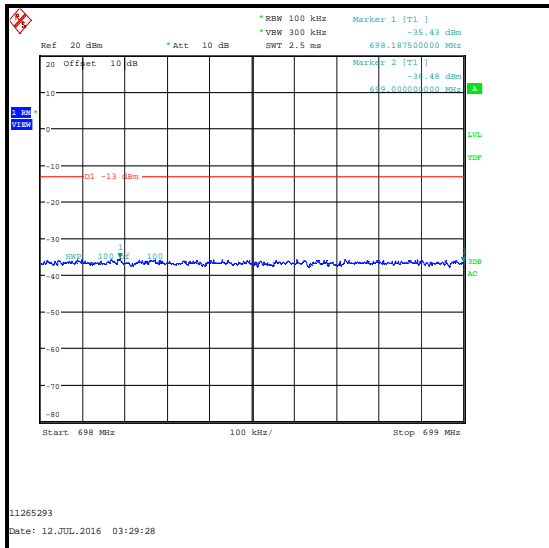

QPSK / 1 RB 24 offset / Lower Band Edge

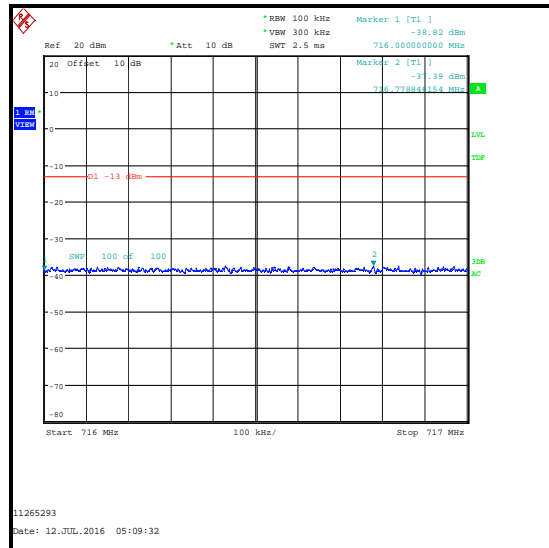

QPSK / 1 RB 0 offset / Upper Band Edge

Transmitter Radiated Emissions at Band Edges (continued) - LAT

Results: 5 MHz Channel Bandwidth / 16QAM

Frequency (MHz)	Resource Block(s)	Resource Block Offset	Emission Level (dBm)	Limit (dBm)	Margin (dB)	Result
698.995	25	0	-26.0	-13.0	13.0	Complied
699	25	0	-26.2	-13.0	13.2	Complied
716	25	0	-24.3	-13.0	11.3	Complied

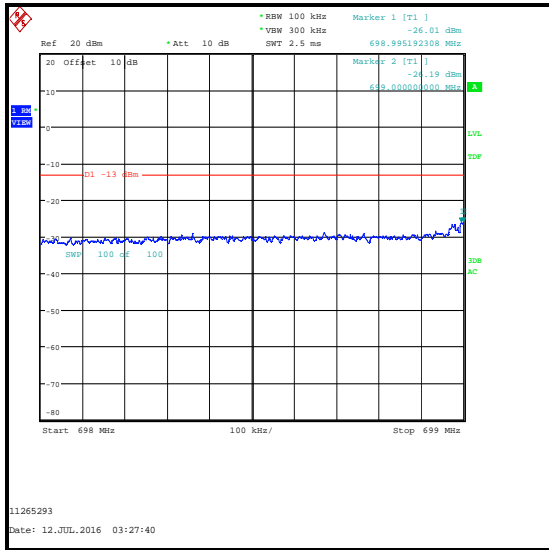

16QAM / Lower Band Edge

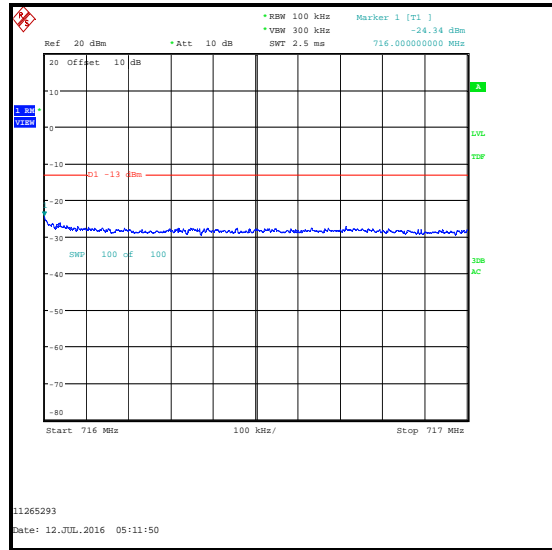

16QAM / Upper Band Edge

Transmitter Radiated Emissions at Band Edges (continued) - LAT

Results: 5 MHz Channel Bandwidth / 16QAM

Frequency (MHz)	Resource Block(s)	Resource Block Offset	Emission Level (dBm)	Limit (dBm)	Margin (dB)	Result
698.987	1	0	-17.1	-13.0	4.1	Complied
699	1	0	-20.0	-13.0	7.0	Complied
716	1	24	-18.5	-13.0	5.5	Complied
699	1	24	-36.9	-13.0	23.9	Complied
716	1	0	-38.2	-13.0	25.2	Complied

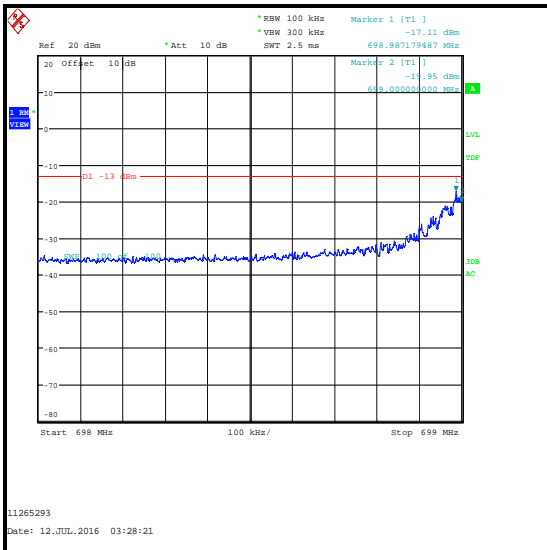

16QAM / 1 RB 0 offset / Lower Band Edge

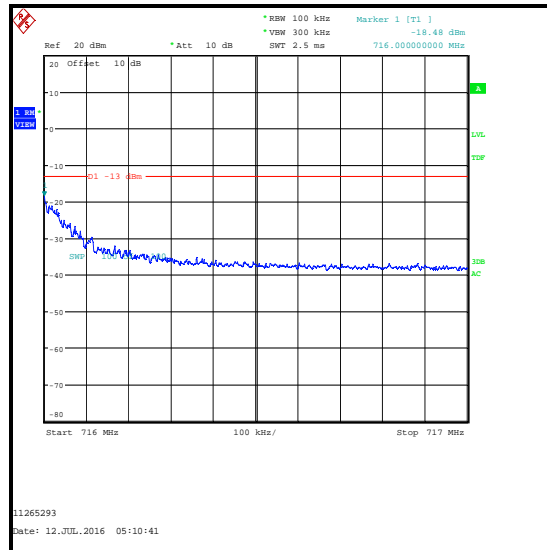

16QAM / 1 RB 24 offset / Upper Band Edge

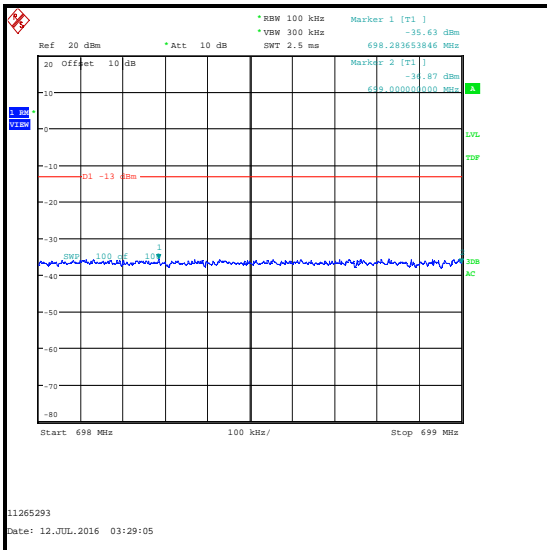

16QAM / 1 RB 24 offset / Lower Band Edge

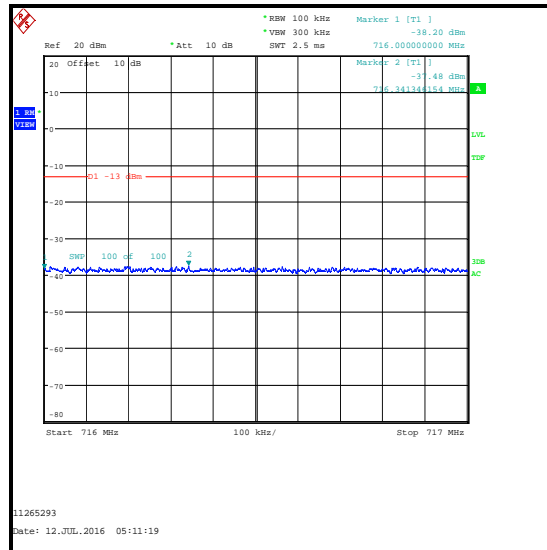

16QAM / 1 RB 0 offset / Upper Band Edge

Transmitter Radiated Emissions at Band Edges (continued) - LAT

Results: 10 MHz Channel Bandwidth / QPSK

Frequency (MHz)	Resource Block(s)	Resource Block Offset	Emission Level (dBm)	Limit (dBm)	Margin (dB)	Result
698.792	50	0	-23.4	-13.0	10.4	Complied
699	50	0	-24.1	-13.0	11.1	Complied
716	50	0	-27.2	-13.0	14.2	Complied
716.074	50	0	-26.2	-13.0	13.2	Complied

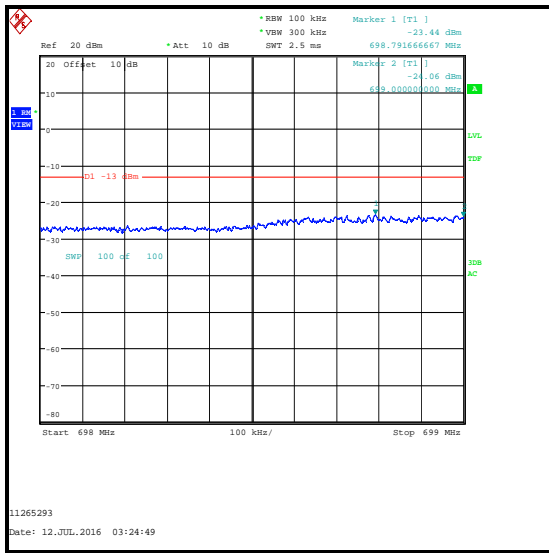

QPSK / Lower Band Edge

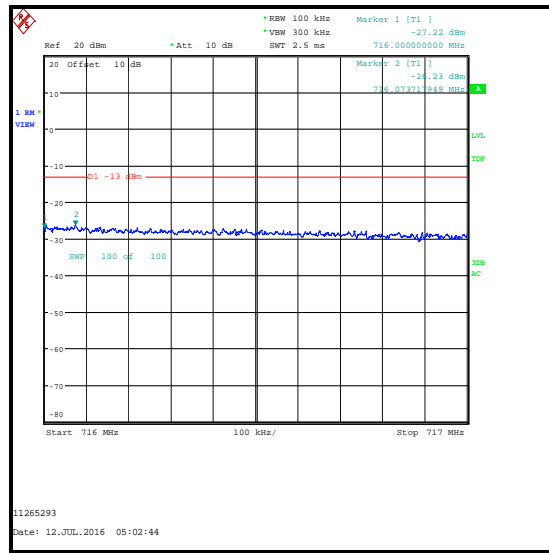

QPSK / Upper Band Edge

Transmitter Radiated Emissions at Band Edges (continued) - LAT

Results: 10 MHz Channel Bandwidth / QPSK

Frequency (MHz)	Resource Block(s)	Resource Block Offset	Emission Level (dBm)	Limit (dBm)	Margin (dB)	Result
698.992	1	0	-30.9	-13.0	17.9	Complied
699	1	0	-33.5	-13.0	20.5	Complied
716	1	49	-34.5	-13.0	21.5	Complied
716.010	1	49	-33.9	-13.0	20.9	Complied
699	1	49	-36.5	-13.0	23.5	Complied
716	1	0	-38.4	-13.0	25.4	Complied

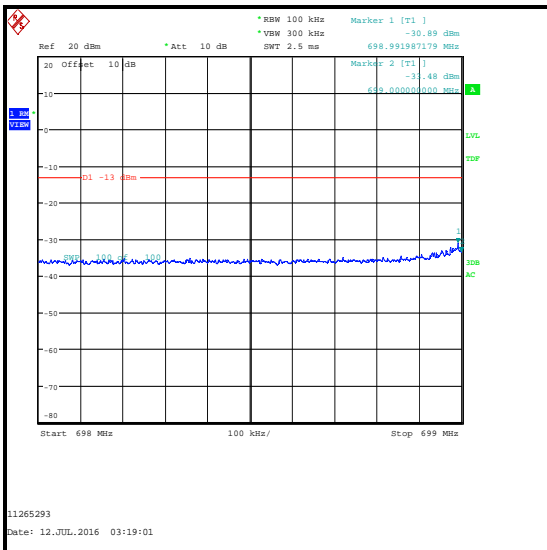

QPSK / 1 RB 0 offset / Lower Band Edge

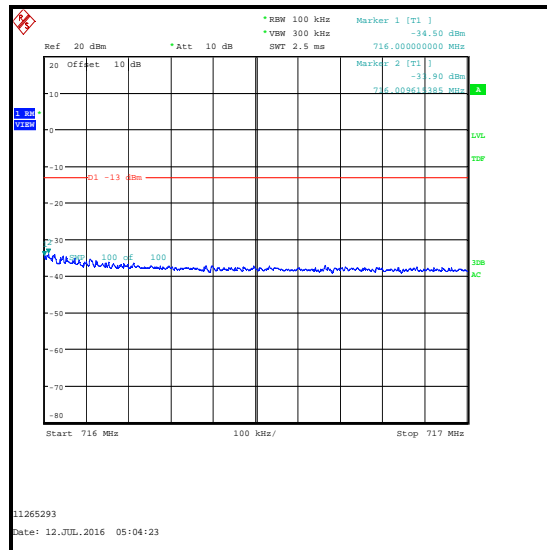

QPSK / 1 RB 49 offset / Upper Band Edge

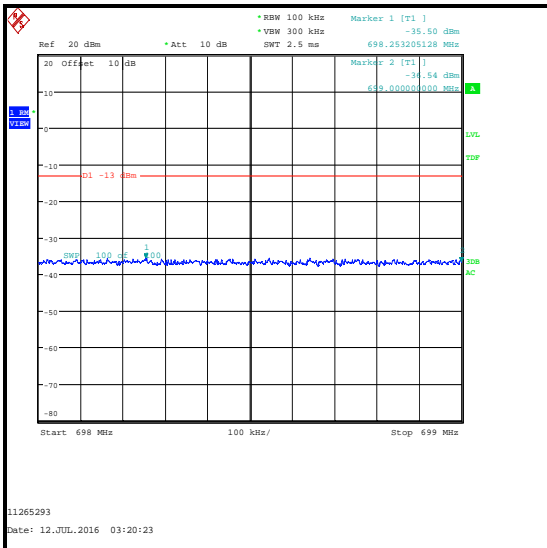

QPSK / 1 RB 49 offset / Lower Band Edge

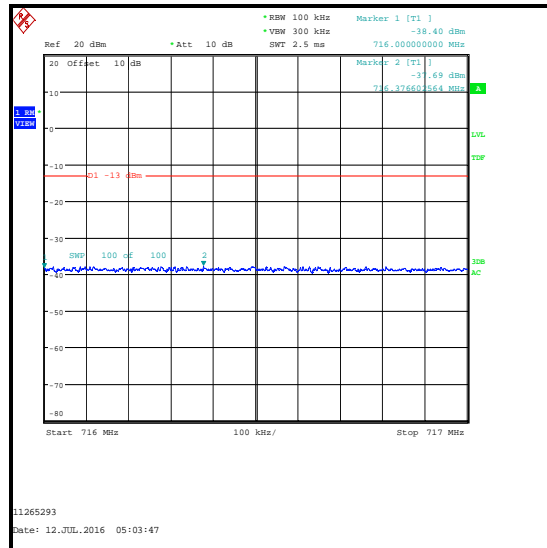

QPSK / 1 RB 0 offset / Upper Band Edge

Transmitter Radiated Emissions at Band Edges (continued) - LAT

Results: 10 MHz Channel Bandwidth / 16QAM

Frequency (MHz)	Resource Block(s)	Resource Block Offset	Emission Level (dBm)	Limit (dBm)	Margin (dB)	Result
698.974	50	0	-24.5	-13.0	11.5	Complied
699	50	0	-25.5	-13.0	12.5	Complied
716	50	0	-28.5	-13.0	15.5	Complied
716.019	50	0	-27.9	-13.0	14.9	Complied

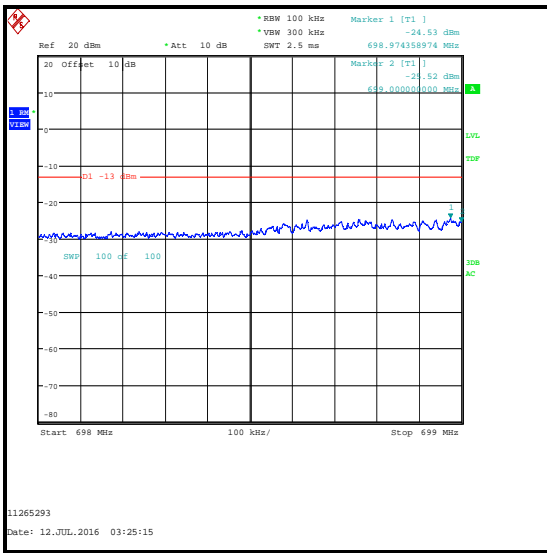

16QAM / Lower Band Edge

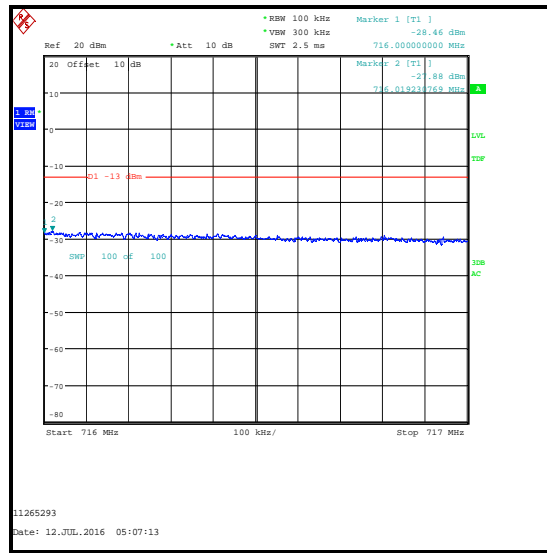

16QAM / Upper Band Edge

Transmitter Radiated Emissions at Band Edges (continued) - LAT

Results: 10 MHz Channel Bandwidth / 16QAM

Frequency (MHz)	Resource Block(s)	Resource Block Offset	Emission Level (dBm)	Limit (dBm)	Margin (dB)	Result
699	1	0	-30.5	-13.0	17.5	Complied
716	1	49	-32.3	-13.0	19.3	Complied
699	1	49	-36.1	-13.0	23.1	Complied
716	1	0	-38.1	-13.0	25.1	Complied

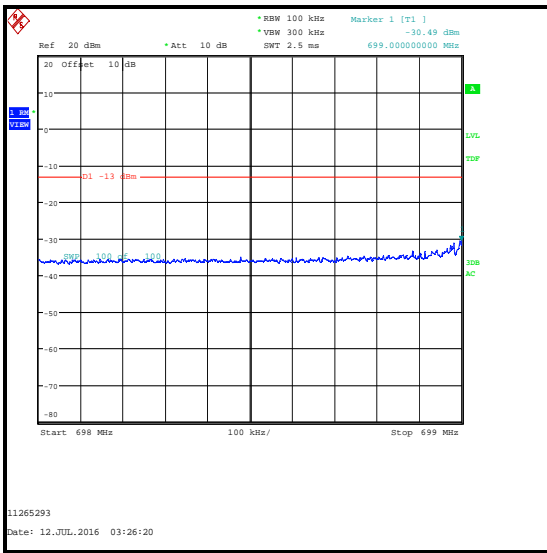

16QAM / 1 RB 0 offset / Lower Band Edge

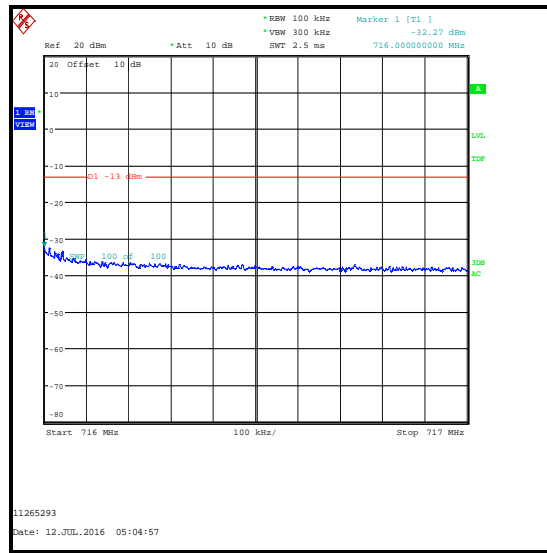

16QAM / 1 RB 49 offset / Upper Band Edge

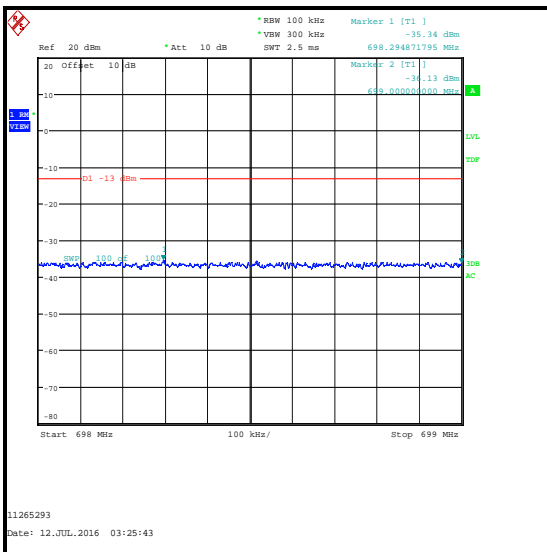

16QAM / 1 RB 49 offset / Lower Band Edge

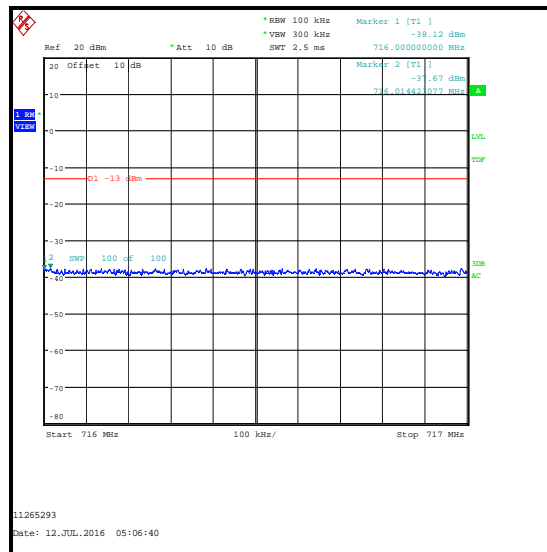

16QAM / 1 RB 0 offset / Upper Band Edge

Transmitter Radiated Emissions at Band Edges (continued) - LAT**Test Equipment Used:**

Asset No.	Instrument	Manufacturer	Type No.	Serial No.	Date Calibration Due	Cal. Interval (Months)
M2003	Thermohygrometer	Testo	608-H1	45046641	22 Apr 2017	12
K0017	3m RSE Chamber	Rainford EMC	N/A	N/A	17 May 2017	12
M1995	Test Receiver	Rohde & Schwarz	ESU40	100428	21 Mar 2017	12
A2888	Antenna	Schwarzbeck	VULB 9163	9163-941	07 Apr 2017	12
A2916	Attenuator	AtlanTecRF	AN18W5-10	832827#1	19 May 2017	12

5.2.7. Transmitter Radiated Emissions at Band Edges - UAT**Test Summary:**

Test Engineer:	Andrew Edwards	Test Dates:	13 July 2016 & 20 July 2016
Test Sample IMEI:	358640070309175		

FCC Reference:	Parts 2.1053 & 27.53(g)
Test Method Used:	KDB 971168 Section 6.1 referencing FCC Part 27.53

Environmental Conditions:

Temperature (°C):	25 to 26
Relative Humidity (%):	38 to 40

Note(s):

1. Measurements were performed with the EUT transmitting QPSK and 16QAM modulation schemes, with the maximum resource blocks settings.
2. Measurements were performed in a semi anechoic chamber (Asset Number K0017) at a distance of 3 metres. The EUT was placed at a height of 80 cm above the reference ground plane in the centre of the chamber turntable. Maximum emission levels were determined by height searching the measurement antenna over the range 1 metre to 4 metres. In the first 1.0 MHz immediately outside and adjacent to the band, the test receiver resolution bandwidth was set to 100 kHz and the video bandwidth was set to 300 kHz. Sweep time was set to auto and an RMS detector with trace averaging of at least 100 sweeps was used.
3. * In accordance with FCC Part 27.53 (g); a relaxed resolution bandwidth of 30 kHz may be employed for the first 100 kHz immediately outside and adjacent to the licensee's frequency block.

Transmitter Radiated Emissions at Band Edges (continued) - UAT

Results: 1.4 MHz Channel Bandwidth / QPSK

Frequency (MHz)	Resource Block(s)	Resource Block Offset	Emission Level (dBm)	Limit (dBm)	Margin (dB)	Result
698.998	6	0	-22.6	-13.0	9.6	Complied
699	6	0	-22.7	-13.0	9.7	Complied
716	6	0	-23.0	-13.0	10.0	Complied
716.002	6	0	-22.6	-13.0	9.6	Complied

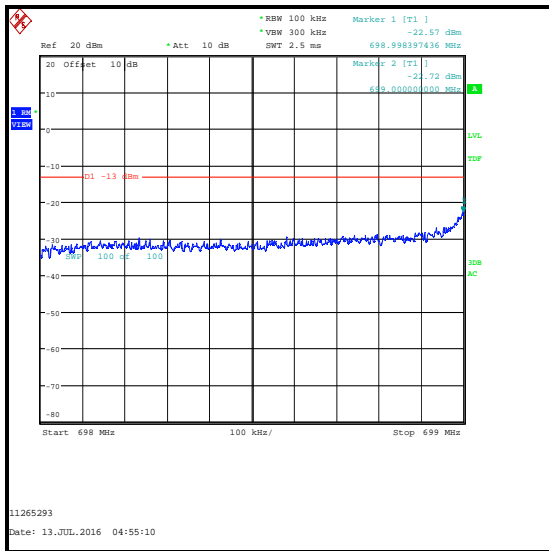

QPSK / Lower Band Edge

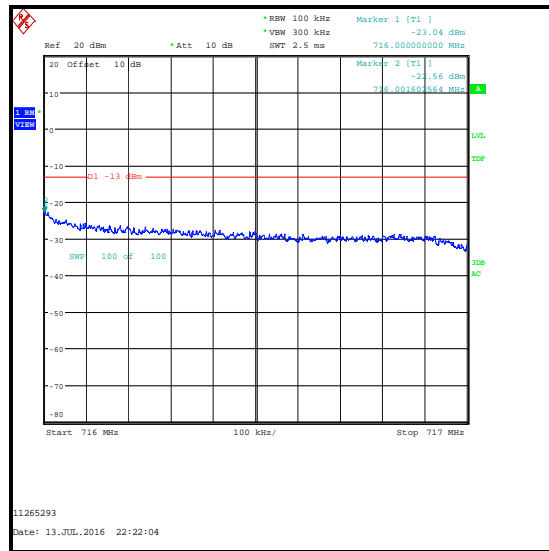

QPSK / Upper Band Edge

Transmitter Radiated Emissions at Band Edges (continued) - UAT

Results: 1.4 MHz Channel Bandwidth / QPSK

Frequency (MHz)	Resource Block(s)	Resource Block Offset	Emission Level (dBm)	Limit (dBm)	Margin (dB)	Result
698.998	1	0	-15.2	-13.0	2.2	Complied
699	1	0	-15.3	-13.0	2.3	Complied
716	1	5	-15.2	-13.0	2.2	Complied
716.002	1	5	-14.9	-13.0	1.9	Complied
699	1	5	-35.4	-13.0	22.4	Complied
716	1	0	-37.9	-13.0	24.9	Complied

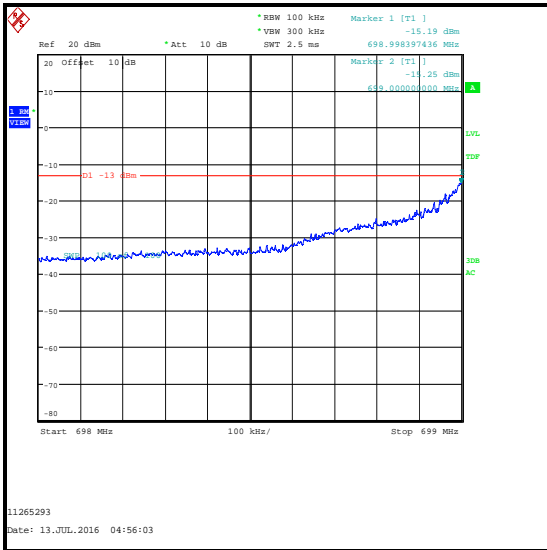

QPSK / 1 RB 0 offset / Lower Band Edge

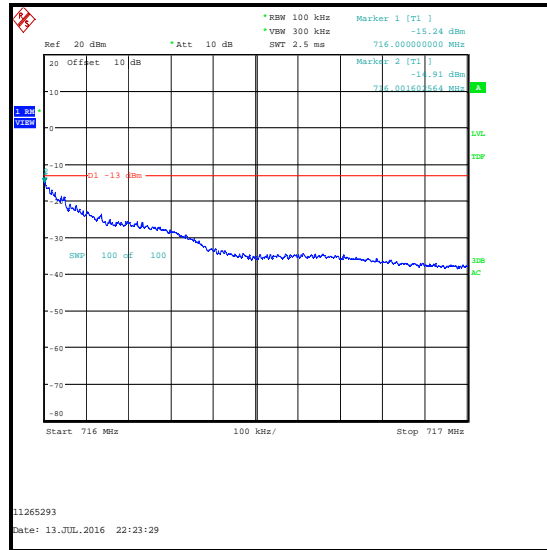

QPSK / 1 RB 5 offset / Upper Band Edge

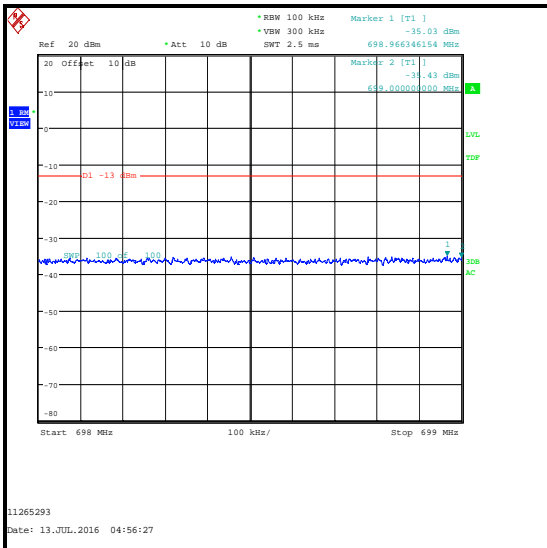

QPSK / 1 RB 5 offset / Lower Band Edge

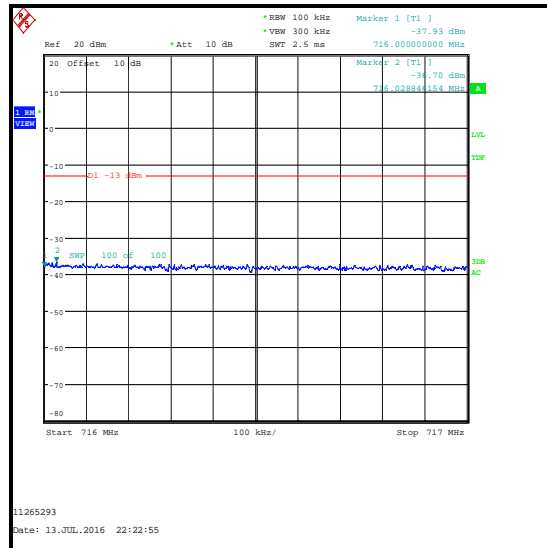

QPSK / 1 RB 0 offset / Upper Band Edge

Transmitter Radiated Emissions at Band Edges (continued) - UAT

Results: 1.4 MHz Channel Bandwidth / 16QAM

Frequency (MHz)	Resource Block(s)	Resource Block Offset	Emission Level (dBm)	Limit (dBm)	Margin (dB)	Result
698.995	6	0	-24.5	-13.0	111.5	Complied
699	6	0	-24.8	-13.0	11.8	Complied
716	6	0	-23.6	-13.0	10.6	Complied

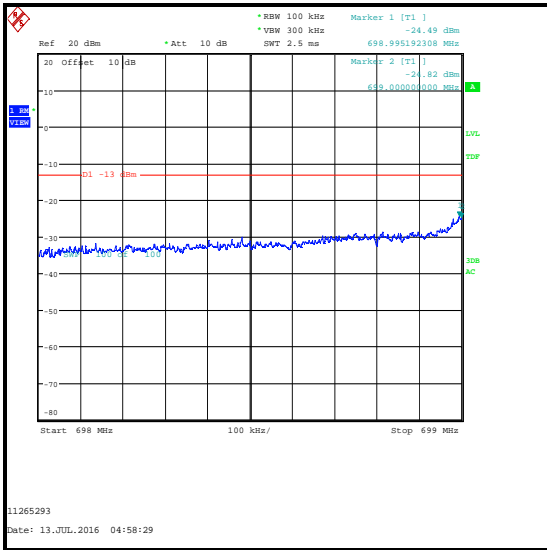

16QAM / Lower Band Edge

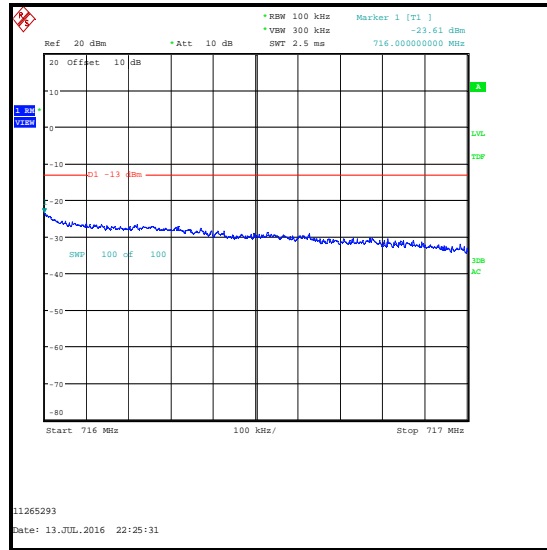

16QAM / Upper Band Edge

Transmitter Radiated Emissions at Band Edges (continued) - UAT

Results: 1.4 MHz Channel Bandwidth / 16QAM

Frequency (MHz)	Resource Block(s)	Resource Block Offset	Emission Level (dBm)	Limit (dBm)	Margin (dB)	Result
699	1	0	-15.0	-13.0	2.0	Complied
716	1	5	-16.0	-13.0	3.0	Complied
699	1	5	-35.6	-13.0	22.6	Complied
716	1	0	-37.2	-13.0	24.2	Complied

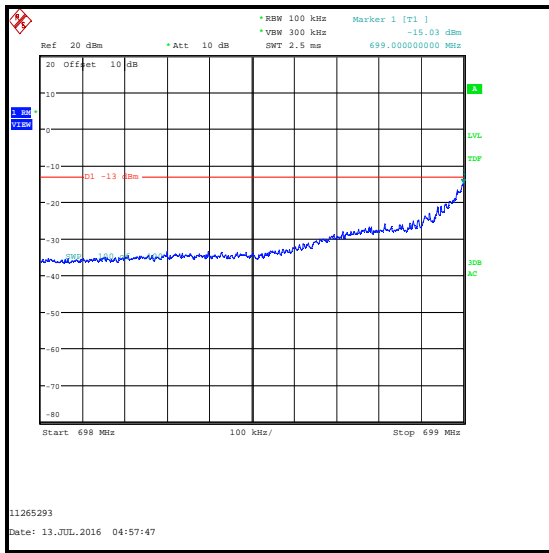

16QAM / 1 RB 0 offset / Lower Band Edge

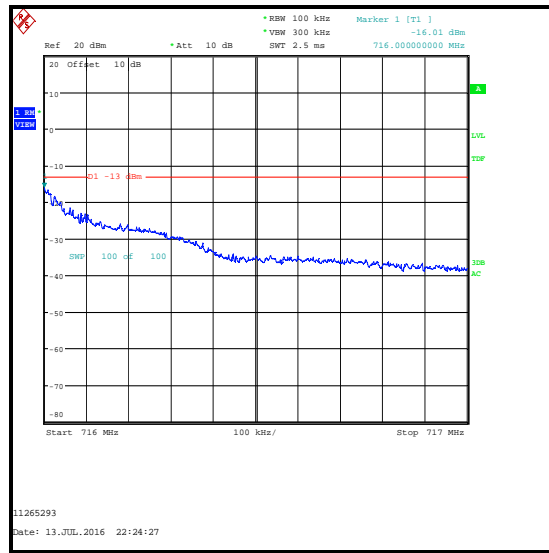

16QAM / 1 RB 5 offset / Upper Band Edge

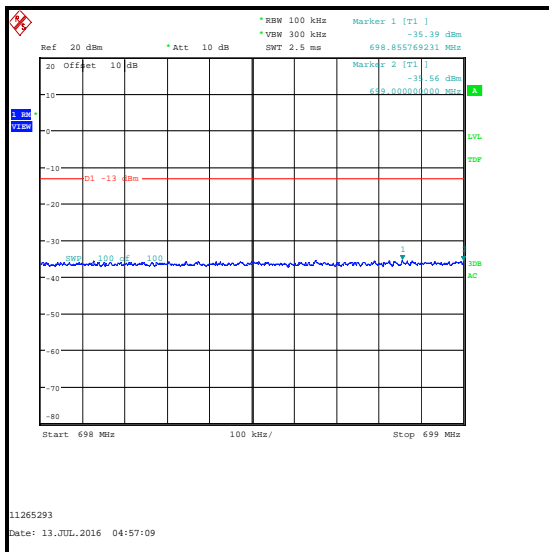

16QAM / 1 RB 5 offset / Lower Band Edge

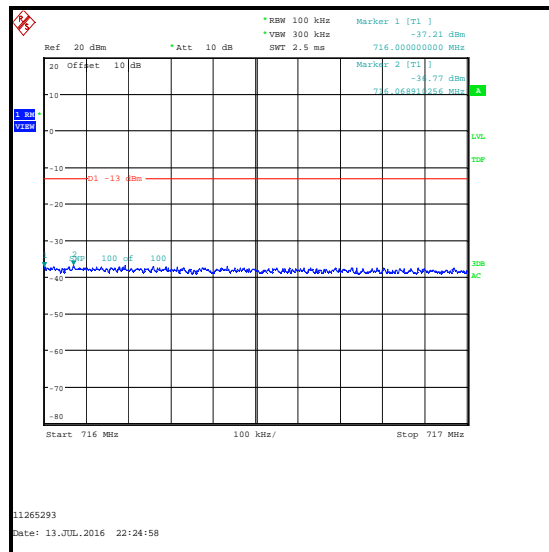

16QAM / 1 RB 0 offset / Upper Band Edge

Transmitter Radiated Emissions at Band Edges (continued) - UAT

Results: 3 MHz Channel Bandwidth / QPSK

Frequency (MHz)	Resource Block(s)	Resource Block Offset	Emission Level (dBm)	Limit (dBm)	Margin (dB)	Result
698.984	15	0	-20.0	-13.0	7.0	Complied
699	15	0	-22.0	-13.0	9.0	Complied
716	15	0	-21.1	-13.0	8.1	Complied
716.003	15	0	-17.8	-13.0	4.8	Complied

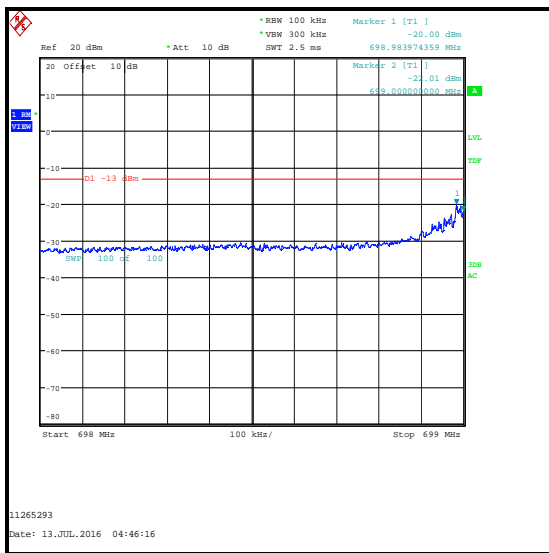

QPSK / Lower Band Edge

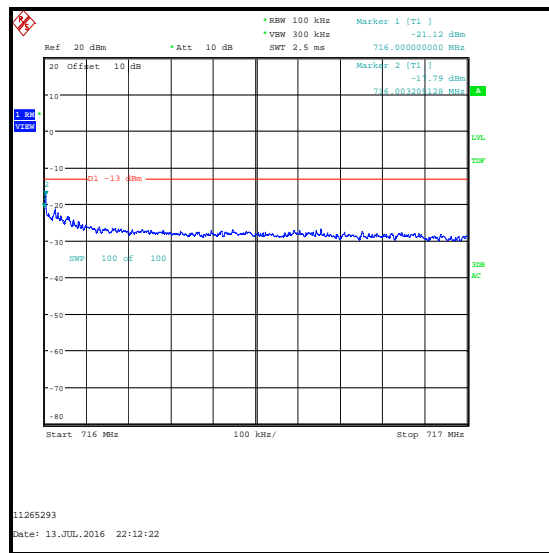

QPSK / Upper Band Edge

Transmitter Radiated Emissions at Band Edges (continued) - UAT

Results: 3 MHz Channel Bandwidth / QPSK

Frequency (MHz)	Resource Block(s)	Resource Block Offset	Emission Level (dBm)	Limit (dBm)	Margin (dB)	Result
698.900	1	0	-22.6	-13.0	9.6	Complied
698.999	1	0	-18.9*	-13.0	5.9	Complied
699	1	0	-19.6*	-13.0	6.6	Complied
716	1	14	-19.9*	-13.0	6.9	Complied
716.000	1	14	-19.2*	-13.0	6.2	Complied
716.101	1	14	-21.5	-13.0	8.5	Complied
699	1	14	-36.7	-13.0	23.7	Complied
716	1	0	-37.8	-13.0	24.8	Complied

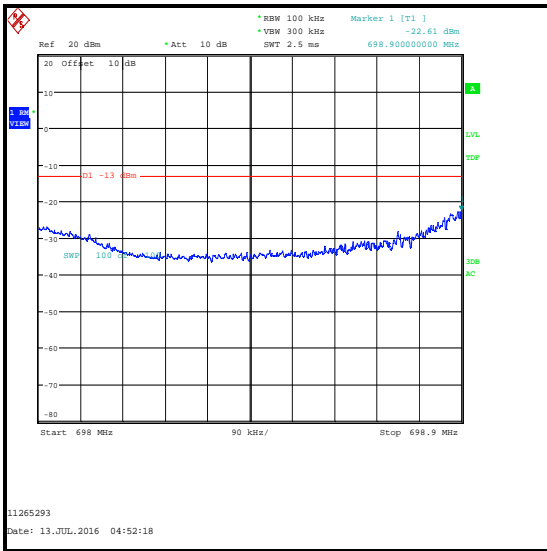

QPSK / 1 RB 0 offset / Lower Band Edge / 689 MHz to 689.9 MHz

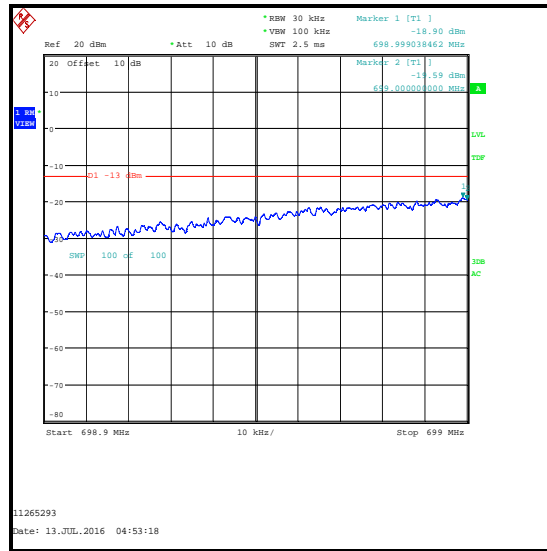

QPSK / 1 RB 0 offset / Lower Band Edge / 689.9 MHz to 699 MHz

Transmitter Radiated Emissions at Band Edges (continued) - UAT

Results: 3 MHz Channel Bandwidth / QPSK

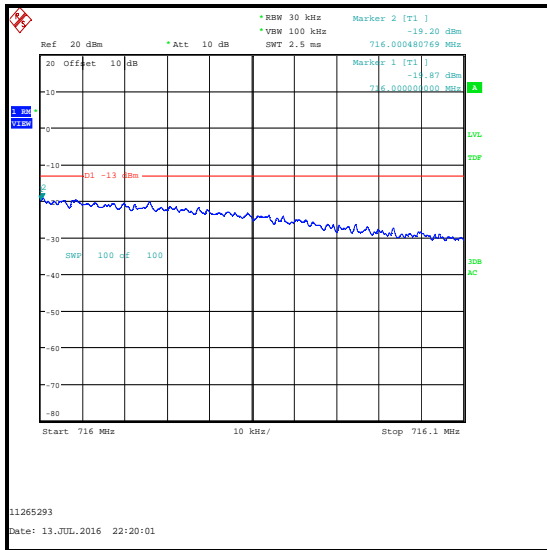

QPSK / 1 RB 14 offset / Upper Band Edge / 716 MHz to 716.1 MHz

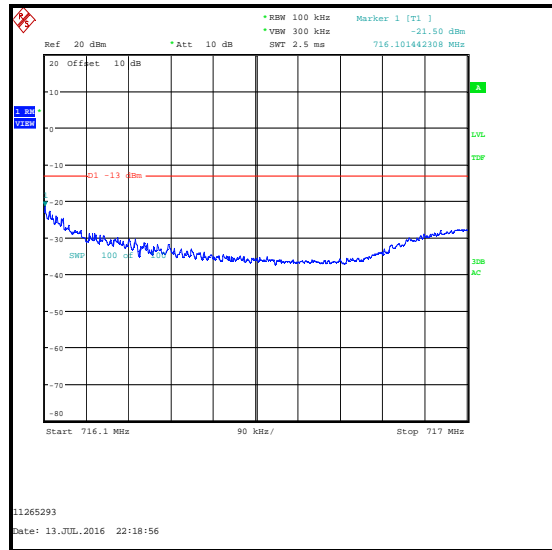

QPSK / 1 RB 14 offset / Upper Band Edge / 716.1 MHz to 717 MHz

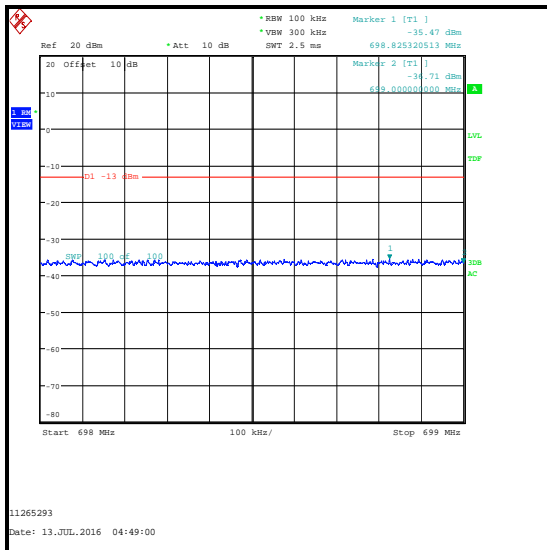

QPSK / 1 RB 14 offset / Lower Band Edge

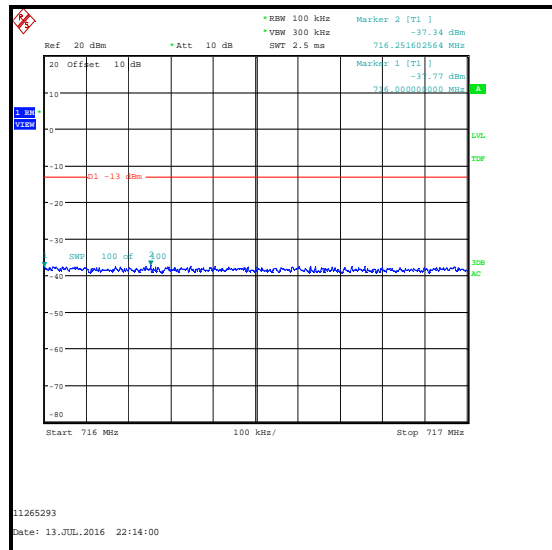

QPSK / 1 RB 0 offset / Upper Band Edge

Transmitter Radiated Emissions at Band Edges (continued) - UAT

Results: 3 MHz Channel Bandwidth / 16QAM

Frequency (MHz)	Resource Block(s)	Resource Block Offset	Emission Level (dBm)	Limit (dBm)	Margin (dB)	Result
698.987	15	0	-20.7	-13.0	7.7	Complied
699	15	0	-22.9	-13.0	9.9	Complied
716	15	0	-21.7	-13.0	8.7	Complied
716.002	15	0	-21.6	-13.0	8.6	Complied

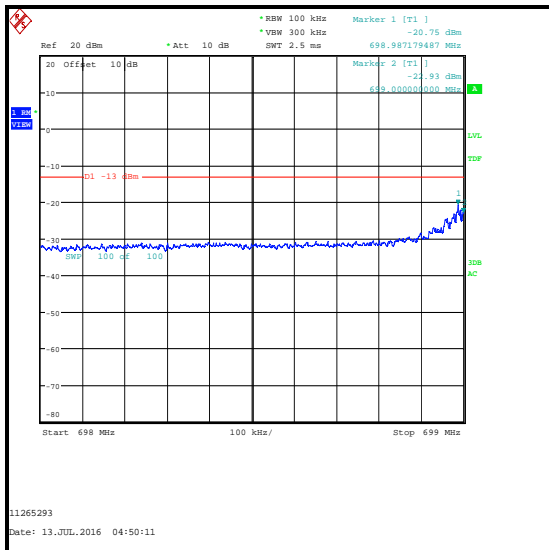

16QAM / Lower Band Edge

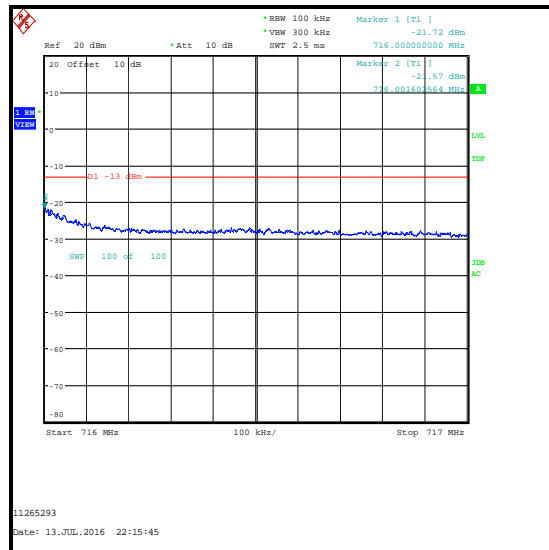

16QAM / Upper Band Edge

Transmitter Radiated Emissions at Band Edges (continued) - UAT

Results: 3 MHz Channel Bandwidth / 16QAM

Frequency (MHz)	Resource Block(s)	Resource Block Offset	Emission Level (dBm)	Limit (dBm)	Margin (dB)	Result
698.899	1	0	-22.8	-13.0	9.8	Complied
698.995	1	0	-20.3*	-13.0	7.3	Complied
699	1	0	-21.3*	-13.0	8.3	Complied
716	1	14	-20.5*	-13.0	7.5	Complied
716.003	1	14	-19.6*	-13.0	6.6	Complied
716.114	1	14	-23.2	-13.0	10.2	Complied
699	1	14	-36.1	-13.0	23.1	Complied
716	1	0	-38.0	-13.0	15.0	Complied

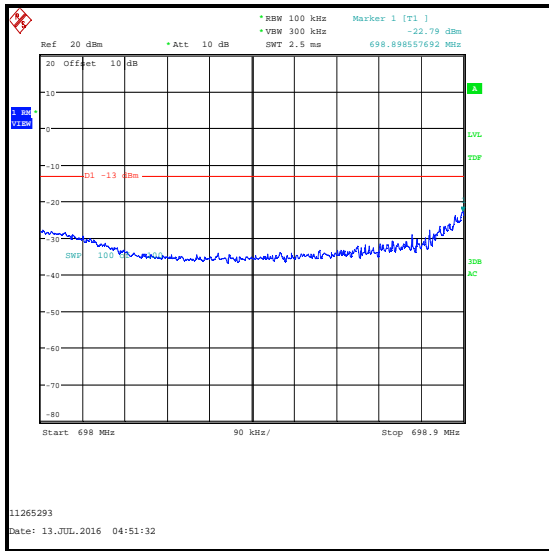

16QAM / 1 RB 0 offset / Lower Band Edge / 689 MHz to 698.9 MHz

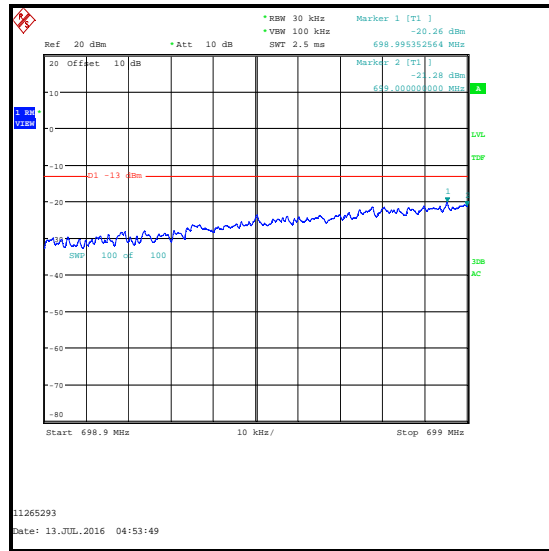

16QAM / 1 RB 0 offset / Lower Band Edge/ 689.9 MHz to 699 MHz

Transmitter Radiated Emissions at Band Edges (continued) - UAT

Results: 3 MHz Channel Bandwidth / 16QAM

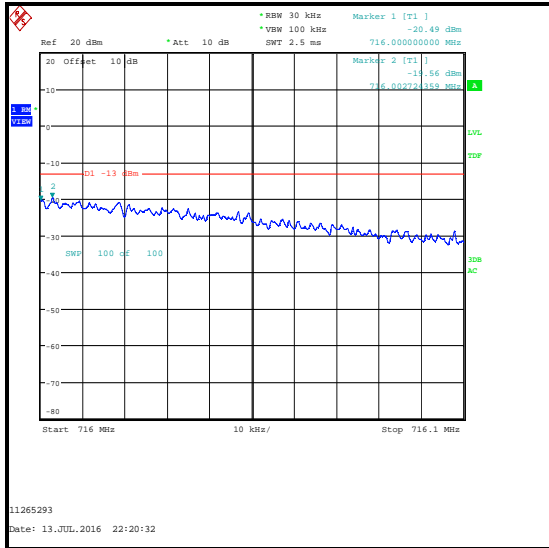

16QAM / 1 RB 14 offset / Upper Band Edge / 716 MHz to 716.1 MHz

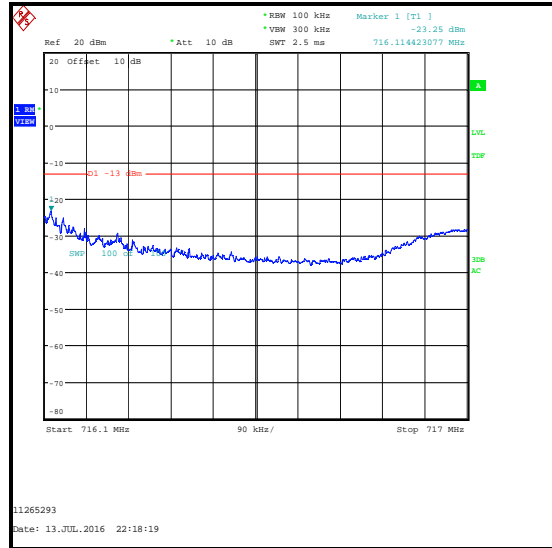

16QAM / 1 RB 14 offset / Upper Band Edge / 716.1 MHz to 717 MHz

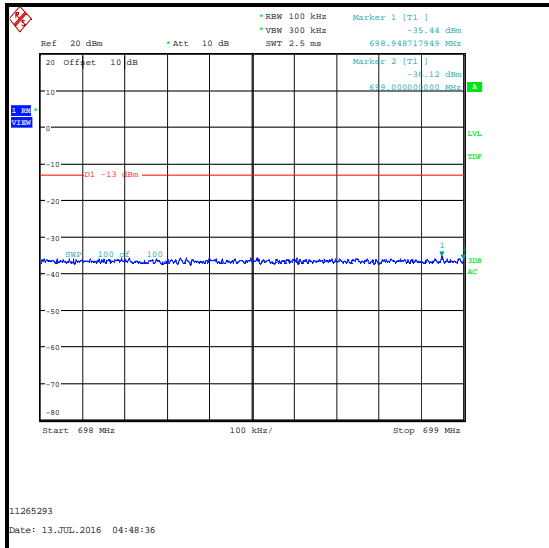

16QAM / 1 RB 14 offset / Lower Band Edge

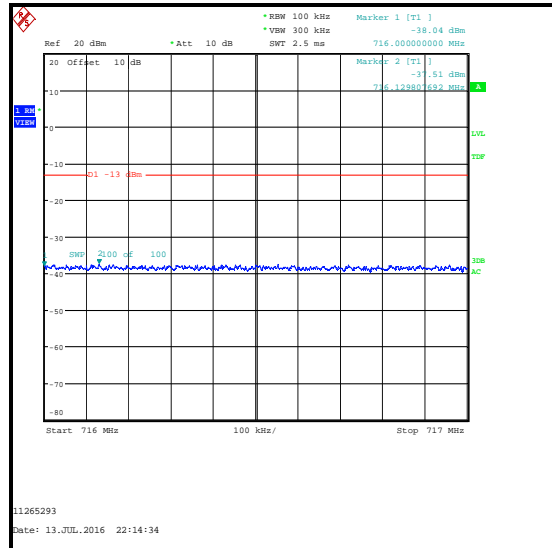

16QAM / 1 RB 0 offset / Upper Band Edge

Transmitter Radiated Emissions at Band Edges (continued) - UAT

Results: 5 MHz Channel Bandwidth / QPSK

Frequency (MHz)	Resource Block(s)	Resource Block Offset	Emission Level (dBm)	Limit (dBm)	Margin (dB)	Result
698.982	25	0	-27.1	-13.0	14.1	Complied
699	25	0	-28.0	-13.0	15.0	Complied
716	25	0	-25.8	-13.0	12.8	Complied
716.018	25	0	-25.1	-13.0	12.1	Complied

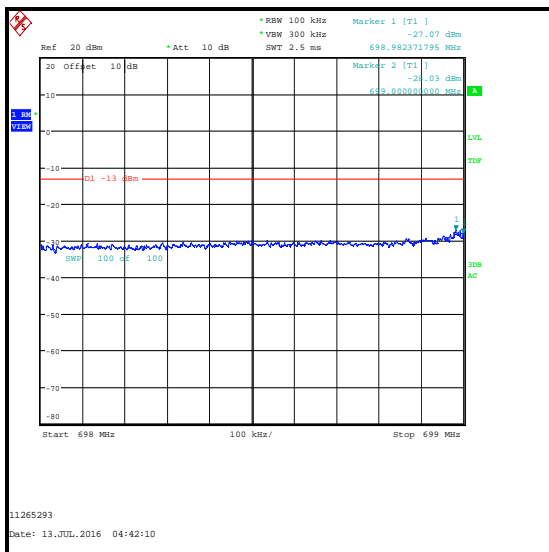

QPSK / Lower Band Edge

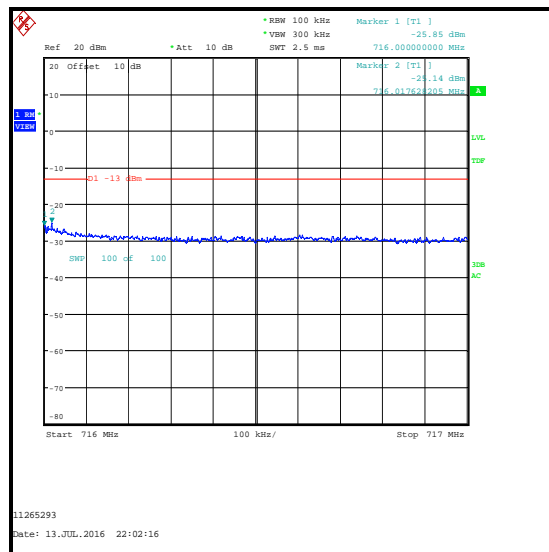

QPSK / Upper Band Edge

Transmitter Radiated Emissions at Band Edges (continued) - UAT

Results: 5 MHz Channel Bandwidth / QPSK

Frequency (MHz)	Resource Block(s)	Resource Block Offset	Emission Level (dBm)	Limit (dBm)	Margin (dB)	Result
698.998	1	0	-17.8	-13.0	4.8	Complied
699	1	0	-17.9	-13.0	4.9	Complied
716	1	24	-18.9	-13.0	5.9	Complied
716.011	1	24	-17.6	-13.0	4.6	Complied
699	1	24	-36.7	-13.0	23.7	Complied
716	1	0	-39.1	-13.0	26.1	Complied

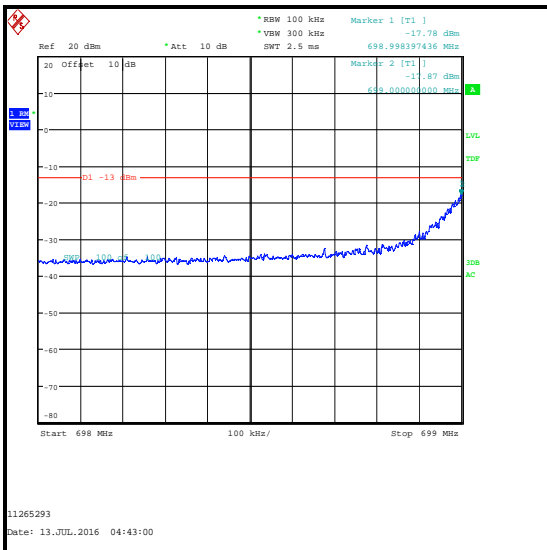

QPSK / 1 RB 0 offset / Lower Band Edge

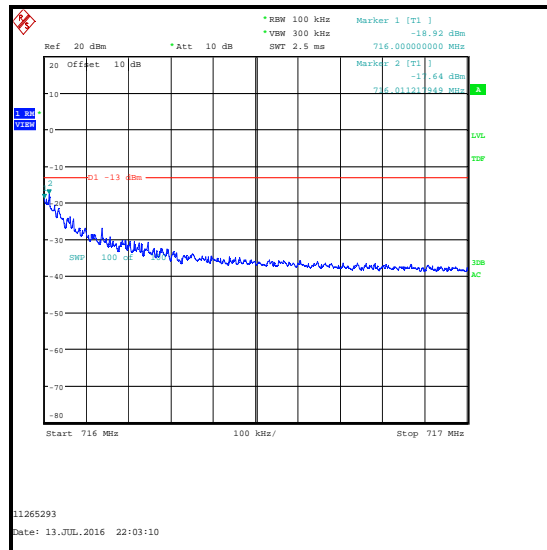

QPSK / 1 RB 24 offset / Upper Band Edge

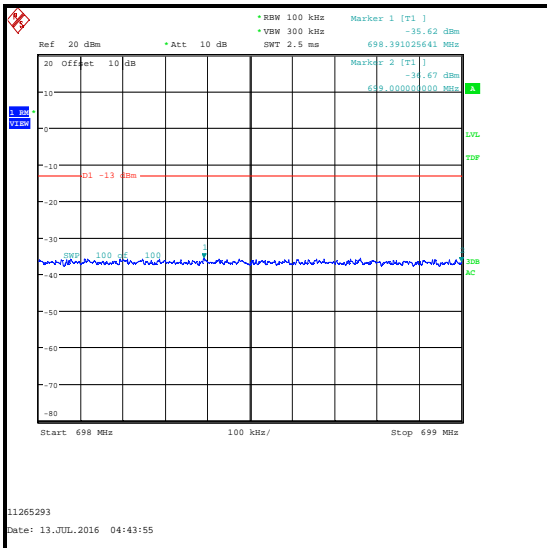

QPSK / 1 RB 24 offset / Lower Band Edge

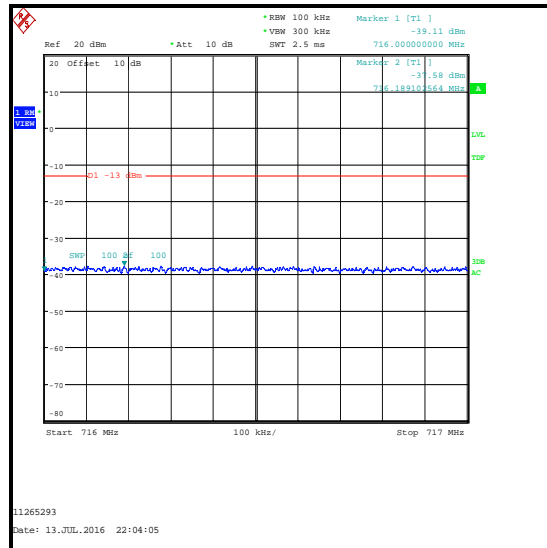

QPSK / 1 RB 0 offset / Upper Band Edge

Transmitter Radiated Emissions at Band Edges (continued) - UAT

Results: 5 MHz Channel Bandwidth / 16QAM

Frequency (MHz)	Resource Block(s)	Resource Block Offset	Emission Level (dBm)	Limit (dBm)	Margin (dB)	Result
698.981	25	0	-27.5	-13.0	14.5	Complied
699	25	0	-28.5	-13.0	15.5	Complied
716	25	0	-27.0	-13.0	14.0	Complied
716.014	25	0	-26.3	-13.0	13.3	Complied

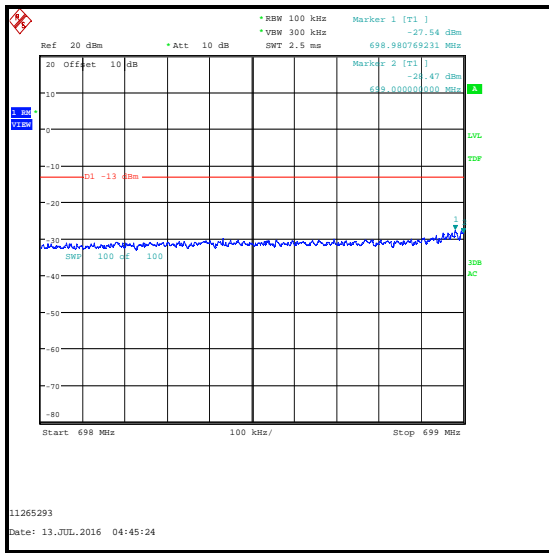

16QAM / Lower Band Edge

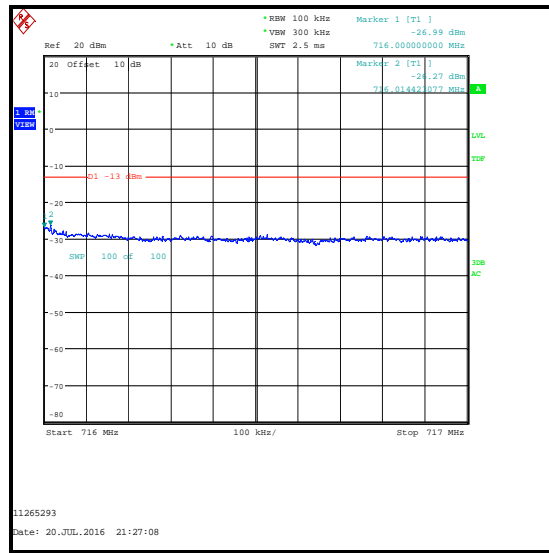

16QAM / Upper Band Edge

Transmitter Radiated Emissions at Band Edges (continued) - UAT

Results: 5 MHz Channel Bandwidth / 16QAM

Frequency (MHz)	Resource Block(s)	Resource Block Offset	Emission Level (dBm)	Limit (dBm)	Margin (dB)	Result
698.992	1	0	-19.1	-13.0	6.1	Complied
699	1	0	-21.5	-13.0	8.5	Complied
716	1	24	-18.9	-13.0	5.9	Complied
716.003	1	24	-18.1	-13.0	5.1	Complied
699	1	24	-36.7	-13.0	23.7	Complied
716	1	0	-38.4	-13.0	25.4	Complied

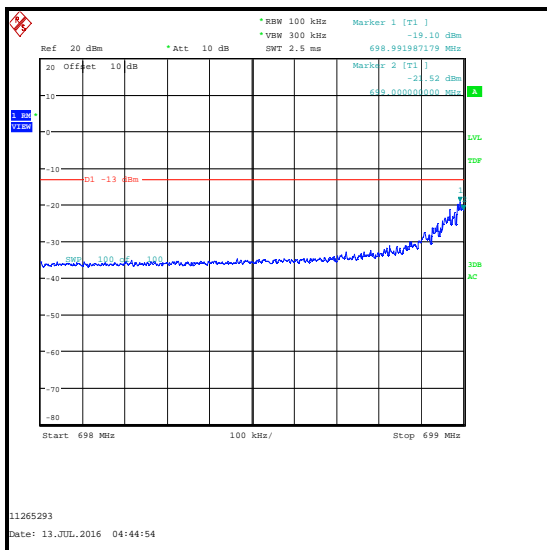

16QAM / 1 RB 0 offset / Lower Band Edge

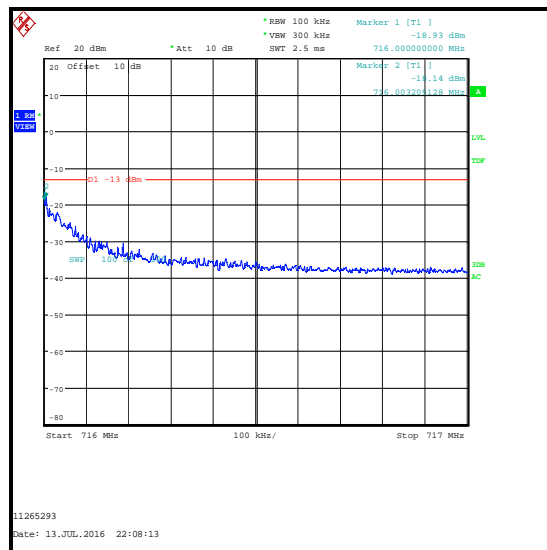

16QAM / 1 RB 24 offset / Upper Band Edge

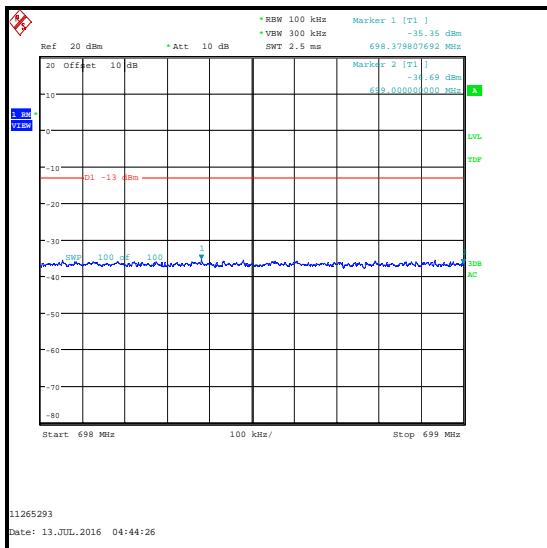

16QAM / 1 RB 24 offset / Lower Band Edge

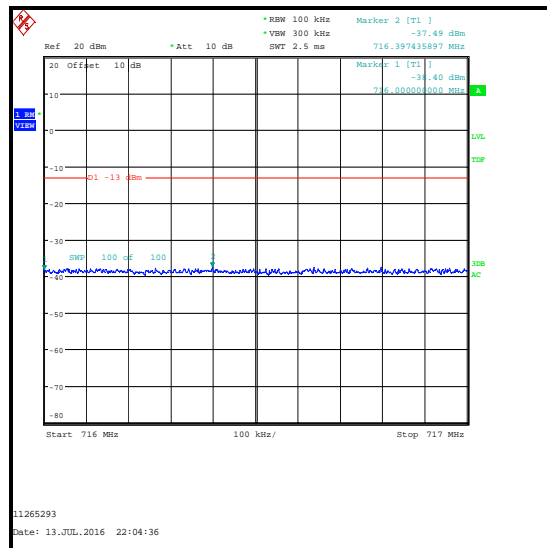

16QAM / 1 RB 0 offset / Upper Band Edge

Transmitter Radiated Emissions at Band Edges (continued) - UAT

Results: 10 MHz Channel Bandwidth / QPSK

Frequency (MHz)	Resource Block(s)	Resource Block Offset	Emission Level (dBm)	Limit (dBm)	Margin (dB)	Result
698.997	50	0	-25.5	-13.0	12.5	Complied
699	50	0	-26.3	-13.0	13.3	Complied
716	50	0	-27.8	-13.0	14.8	Complied
716.071	50	0	-27.5	-13.0	14.5	Complied

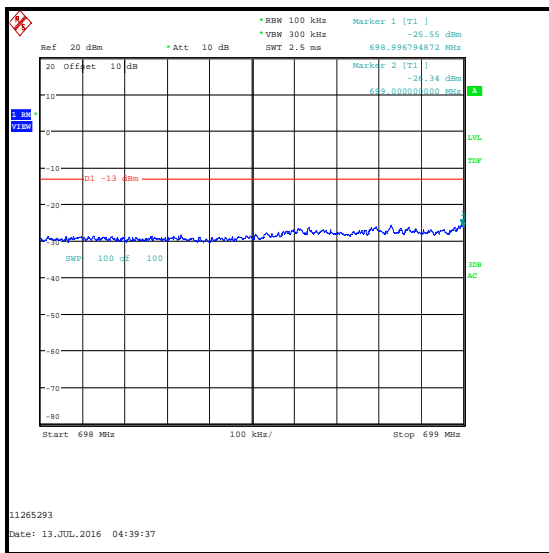

QPSK / Lower Band Edge

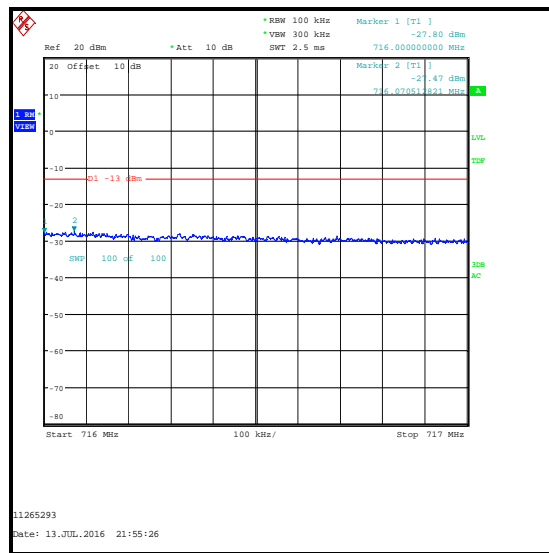

QPSK / Upper Band Edge

Transmitter Radiated Emissions at Band Edges (continued) - UAT

Results: 10 MHz Channel Bandwidth / QPSK

Frequency (MHz)	Resource Block(s)	Resource Block Offset	Emission Level (dBm)	Limit (dBm)	Margin (dB)	Result
698.981	1	0	-31.0	-13.0	18.0	Complied
699	1	0	-31.4	-13.0	18.4	Complied
716	1	49	-30.7	-13.0	17.7	Complied
716.003	1	49	-30.3	-13.0	17.3	Complied
699	1	49	-36.9	-13.0	23.9	Complied
716	1	0	-38.5	-13.0	25.5	Complied

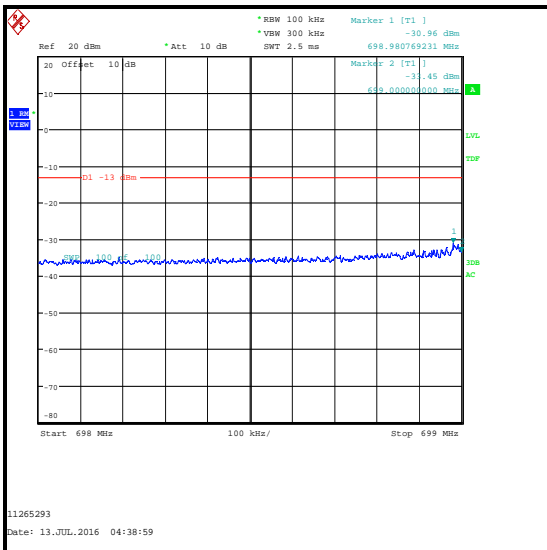

QPSK / 1 RB 0 offset / Lower Band Edge

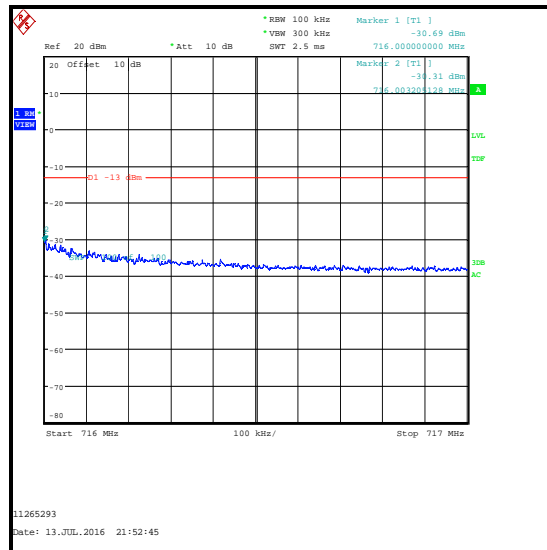

QPSK / 1 RB 49 offset / Upper Band Edge

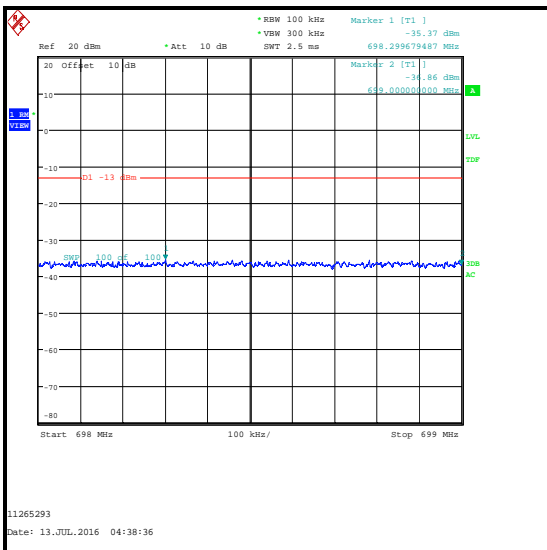

QPSK / 1 RB 49 offset / Lower Band Edge

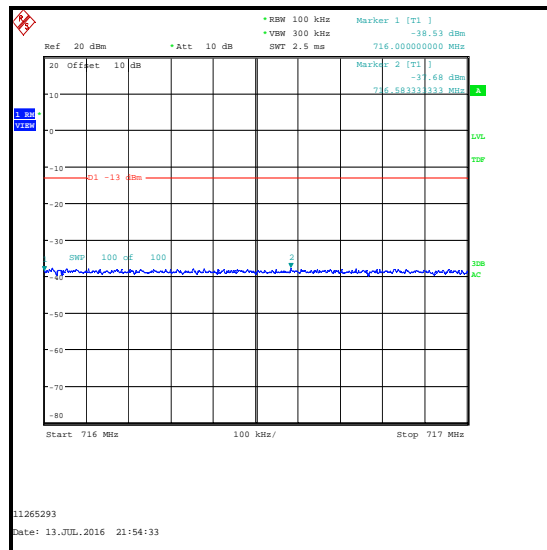

QPSK / 1 RB 0 offset / Upper Band Edge

Transmitter Radiated Emissions at Band Edges (continued) - UAT

Results: 10 MHz Channel Bandwidth / 16QAM

Frequency (MHz)	Resource Block(s)	Resource Block Offset	Emission Level (dBm)	Limit (dBm)	Margin (dB)	Result
698.843	50	0	-27.3	-13.0	14.3	Complied
699	50	0	-28.4	-13.0	15.4	Complied
716	50	0	-30.2	-13.0	17.2	Complied
716.003	50	0	-29.2	-13.0	16.2	Complied

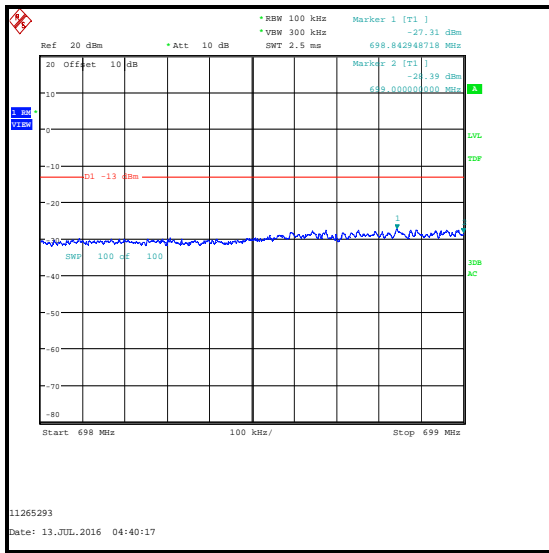

16QAM / Lower Band Edge

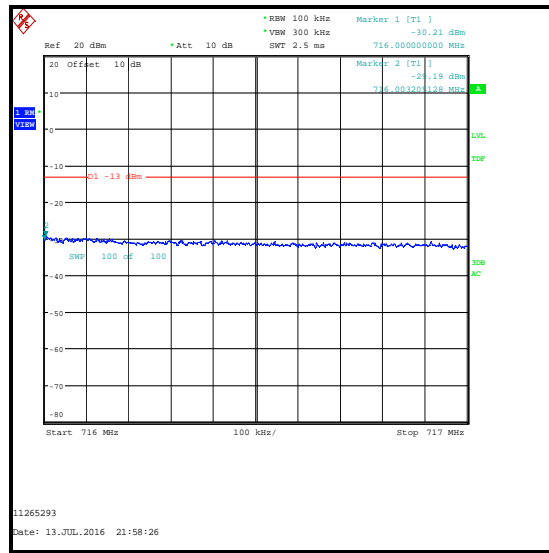

16QAM / Upper Band Edge

Transmitter Radiated Emissions at Band Edges (continued) - UAT

Results: 10 MHz Channel Bandwidth / 16QAM

Frequency (MHz)	Resource Block(s)	Resource Block Offset	Emission Level (dBm)	Limit (dBm)	Margin (dB)	Result
698.986	1	0	-30.7	-13.0	17.7	Complied
699	1	0	-33.0	-13.0	20.0	Complied
716	1	49	-31.8	-13.0	18.8	Complied
716.013	1	49	-31.0	-13.0	18.0	Complied
699	1	49	-37.2	-13.0	24.2	Complied
716	1	0	-38.4	-13.0	25.4	Complied

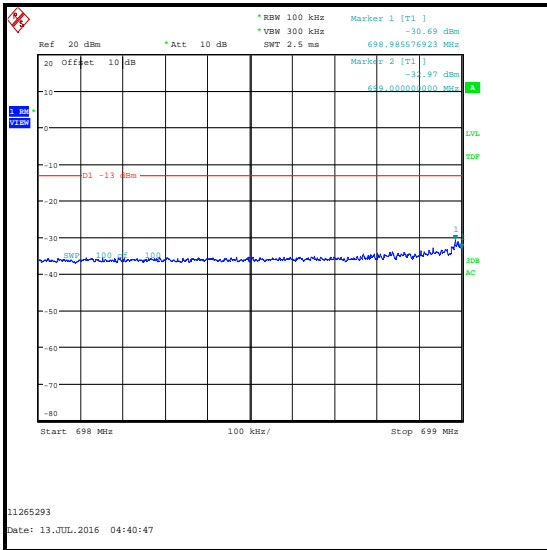

16QAM / 1 RB 0 offset / Lower Band Edge

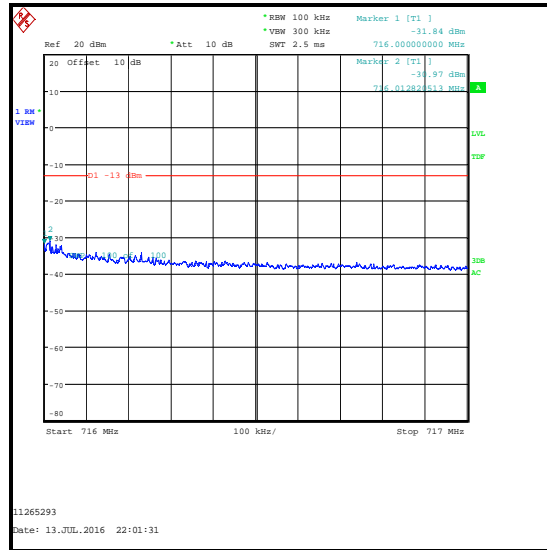

16QAM / 1 RB 49 offset / Upper Band Edge

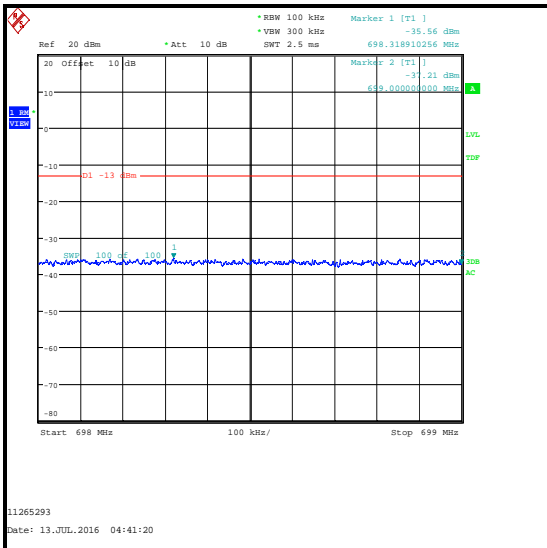

16QAM / 1 RB 49 offset / Lower Band Edge

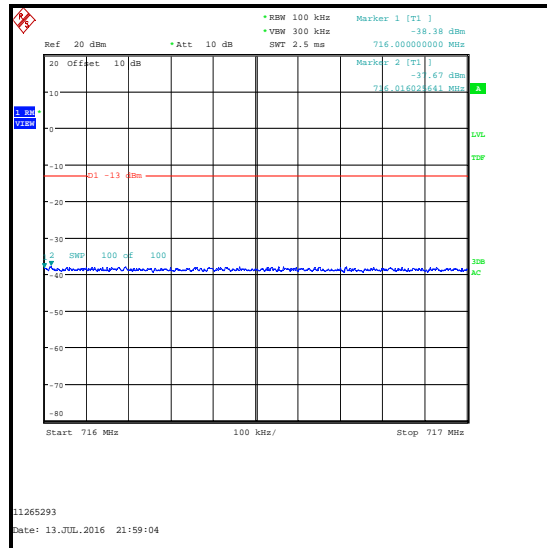

16QAM / 1 RB 0 offset / Upper Band Edge

Transmitter Radiated Emissions at Band Edges (continued) - UAT**Test Equipment Used:**

Asset No.	Instrument	Manufacturer	Type No.	Serial No.	Date Calibration Due	Cal. Interval (Months)
M2003	Thermohygrometer	Testo	608-H1	45046641	22 Apr 2017	12
K0017	3m RSE Chamber	Rainford EMC	N/A	N/A	17 May 2017	12
M1995	Test Receiver	Rohde & Schwarz	ESU40	100428	21 Mar 2017	12
A2888	Antenna	Schwarzbeck	VULB 9163	9163-941	07 Apr 2017	12
A2916	Attenuator	AtlanTecRF	AN18W5-10	832827#1	19 May 2017	12

5.2.8. Transmitter Frequency Stability (Temperature Variation)

Test Summary:

Test Engineer:	Stefan Ho	Test Dates:	03 June 2016 & 09 June 2016
Test Sample IMEI:	358640070266615		

FCC Reference:	Parts 2.1055 & 27.54
Test Method Used:	KDB 971168 Section 9.0 referencing ANSI TIA-603-D-2010 Section 2.2.2 and FCC Part 2.1055

Environmental Conditions:

Temperature (°C):	23
Relative Humidity (%):	46 to 48

Note(s):

1. Flying leads were connected internally to the EUT in place of the battery. These leads extended and connected to a bench power supply at the nominal voltage of 3.8 V.
2. Frequency error was measured using a calibrated Rohde and Schwarz CMW 500 Universal Radio Communications Tester in accordance with current Rohde and Schwarz application notes. The EUT was connected by suitable RF cables to the CMW 500. A bi-directional communications link was established between the EUT and CMW 500. The frequency meter value was recorded.
3. Temperature was monitored throughout the test with a calibrated digital thermometer.

Test setup:

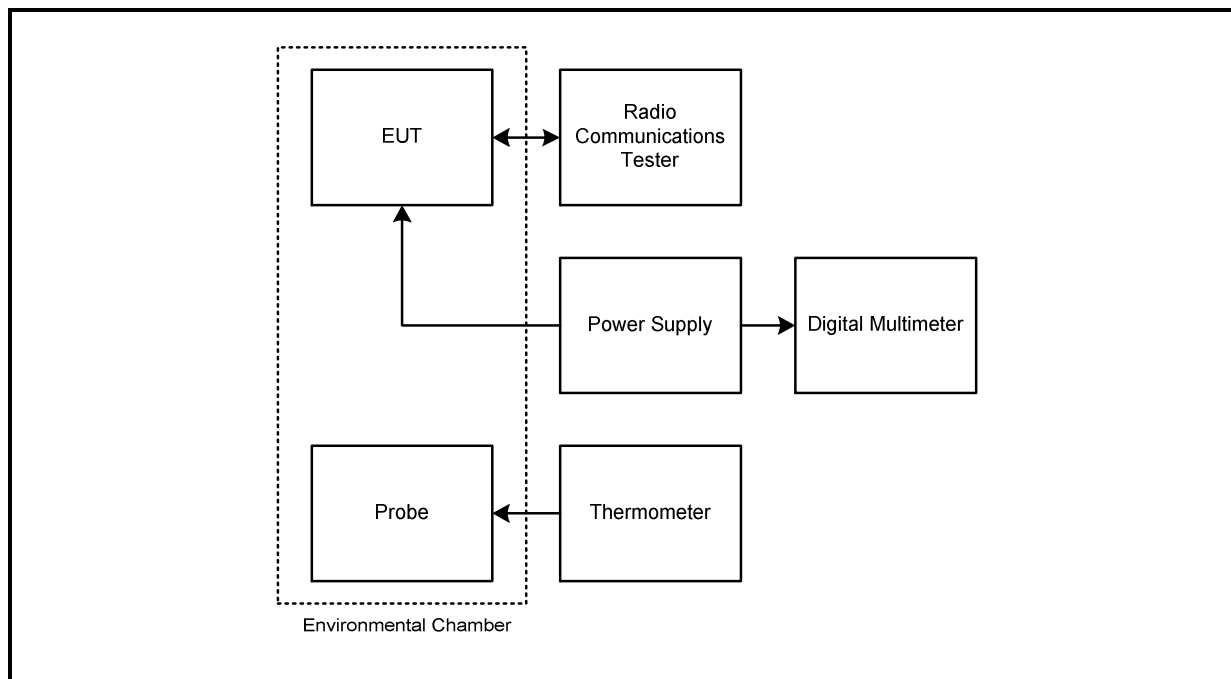

Transmitter Frequency Stability (Temperature Variation) (continued)**Results: Bottom Channel (699.7 MHz)**

Temperature (°C)	Frequency Error (Hz)	Measured Frequency (MHz)	Lower Band Edge Limit (MHz)	Margin (MHz)	Result
-30	4	699.699996	699	0.699996	Complied
-20	4	699.699996	699	0.699996	Complied
-10	3	699.700003	699	0.700003	Complied
0	3	699.700003	699	0.700003	Complied
10	4	699.700004	699	0.700004	Complied
20	4	699.699996	699	0.699996	Complied
30	4	699.699996	699	0.699996	Complied
40	4	699.699996	699	0.699996	Complied
50	3	699.699997	699	0.699997	Complied

Results: Top Channel (715.3 MHz)

Temperature (°C)	Frequency Error (Hz)	Measured Frequency (MHz)	Upper Band Edge Limit (MHz)	Margin (MHz)	Result
-30	5	715.299995	716	0.700005	Complied
-20	4	715.299996	716	0.700004	Complied
-10	4	715.300004	716	0.699996	Complied
0	4	715.300004	716	0.699996	Complied
10	5	715.300005	716	0.699995	Complied
20	4	715.299996	716	0.700004	Complied
30	5	715.299995	716	0.700005	Complied
40	5	715.299995	716	0.700005	Complied
50	4	715.299996	716	0.700004	Complied

Test Equipment Used:

Asset No.	Instrument	Manufacturer	Type No.	Serial No.	Date Calibration Due	Cal. Interval (Months)
M2002	Thermohygrometer	Testo	608-H1	45041825	02 Apr 2017	12
M1869	Wideband Radio Comms Tester	Rohde & Schwarz	CMW 500	145923	05 Apr 2017	12
M1815	Environmental Chamber	Votsch/Heraeus	VT4002	521/83083	Calibrated before use	-
M1642	Thermometer	Fluke	52II	18890119	25 Apr 2017	12
S021	DC power supply	TTI	CPX200	061034	Calibrated before use	-
M1269	Multimeter	Fluke	179	90250210	13 May 2017	12

5.2.9. Transmitter Frequency Stability (Voltage Variation)

Test Summary:

Test Engineer:	Stefan Ho	Test Date:	02 June 2016
Test Sample IMEI:	358640070266615		

FCC Reference:	Parts 2.1055 & 27.54
Test Method Used:	KDB 971168 Section 9.0 referencing ANSI TIA-603-D-2010 Section 2.2.2 and FCC Part 2.1055

Environmental Conditions:

Temperature (°C):	23
Relative Humidity (%):	48

Note(s):

1. Flying leads were connected internally to the EUT in place of the battery. These leads extended and connected to a bench power supply.
2. Frequency error was measured using a calibrated Rohde and Schwarz CMW 500 Universal Radio Communications Tester in accordance with current Rohde and Schwarz application notes. The EUT was connected by suitable RF cables to the CMW 500. A bi-directional communications link was established between the EUT and CMW 500. The frequency meter value was recorded.
3. Voltage was monitored throughout the test with a calibrated digital voltmeter.

Test setup:

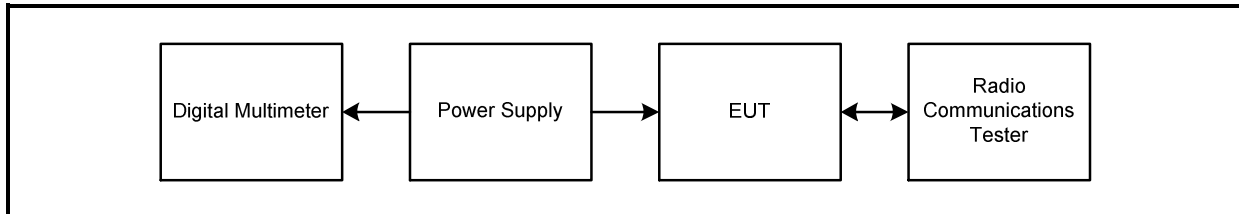

Transmitter Frequency Stability (Voltage Variation) (continued)**Results: Bottom Channel (699.7 MHz)**

Supply Voltage (V)	Frequency Error (Hz)	Measured Frequency (MHz)	Lower Band Edge Limit (MHz)	Margin (MHz)	Result
3.4	4	699.699996	699	0.699996	Complied
4.2	4	699.700004	699	0.700004	Complied

Results: Top Channel (715.3 MHz)

Supply Voltage (V)	Frequency Error (Hz)	Measured Frequency (MHz)	Upper Band Edge Limit (MHz)	Margin (MHz)	Result
3.4	3	715.299997	716	0.700003	Complied
4.2	4	715.299996	716	0.700004	Complied

Test Equipment Used:

Asset No.	Instrument	Manufacturer	Type No.	Serial No.	Date Calibration Due	Cal. Interval (Months)
M2002	Thermohygrometer	Testo	608-H1	45041825	02 Apr 2017	12
M1869	Wideband Radio Comms Tester	Rohde & Schwarz	CMW 500	145923	05 Apr 2017	12
S021	DC power supply	TTI	CPX200	061034	Calibrated before use	-
M1269	Multimeter	Fluke	179	90250210	13 May 2017	12

6. Measurement Uncertainty

No measurement or test can ever be perfect and the imperfections give rise to error of measurement in the results. Consequently the result of a measurement is only an approximation to the value of the measurand (the specific quantity subject to measurement) and is only complete when accompanied by a statement of the uncertainty of the approximation.

The expression of uncertainty of a measurement result allows realistic comparison of results with reference values and limits given in specifications and standards.

The uncertainty of the result may need to be taken into account when interpreting the measurement results.

The reported expanded uncertainties below are based on a standard uncertainty multiplied by an appropriate coverage factor such that a confidence level of approximately 95% is maintained. For the purposes of this document "approximately" is interpreted as meaning "effectively" or "for most practical purposes".

Measurement Type	Range	Confidence Level (%)	Calculated Uncertainty
Conducted Output Power	699 MHz to 716 MHz	95%	±1.36 dB
Frequency Stability	699 MHz to 716 MHz	95%	±23 Hz
Occupied Bandwidth	699 MHz to 716 MHz	95%	±3.92 %
Radiated Spurious Emissions	30 MHz to 1 GHz	95%	±5.65 dB
Radiated Spurious Emissions	1 GHz to 8 GHz	95%	±2.94 dB

The methods used to calculate the above uncertainties are in line with those recommended within the various measurement specifications. Where measurement specifications do not include guidelines for the evaluation of measurement uncertainty the published guidance of the appropriate accreditation body is followed.

7. Report Revision History

Version Number	Revision Details		
	Page No(s)	Clause	Details
1.0	-	-	Initial Version
2.0	-	-	Updates as requested by the TCB

--- END OF REPORT ---