



**FCC CFR47 PART 20.19
ANSI C63.19-2007
HAC RF EMISSIONS TEST REPORT**

FOR
iPhone

MODEL: A1349

FCC ID: BCG-E2422A

REPORT NUMBER: 10U13473-8A

ISSUE DATE: January 9, 2011

Prepared for
Apple Inc.
1 Infinite Loop, MS-26A
Cupertino, CA 95014-2084

Prepared by
COMPLIANCE CERTIFICATION SERVICES (UL CCS)
47173 BENICIA STREET
FREMONT, CA 94538, U.S.A.
TEL: (510) 771-1000
FAX: (510) 661-0888



NVLAP LAB CODE 200065-0

Revision History

<u>Rev.</u>	<u>Issue Date</u>	<u>Revisions</u>	<u>Revised By</u>
--	December 3, 2010	Initial Issue	--
A	January 9, 2011	Added Section 6 List of Air-Interface/Band & Operating modes.	

TABLE OF CONTENTS

1. ATTESTATION OF TEST RESULTS	4
2. TEST METHODOLOGY	5
3. FACILITIES AND ACCREDITATION	5
4. CALIBRATION AND UNCERTAINTY	6
4.1. <i>MEASURING INSTRUMENT CALIBRATION</i>	6
4.2. <i>MEASUREMENT UNCERTAINTY</i>	7
5. EQUIPMENT UNDER TEST	8
6. LIST OF AIR INTERFACES/BANDS & OPERATING MODES	8
7. SYSTEM SPECIFICATIONS	9
8. SYSTEM VALIDATION	10
8.1. <i>SYSTEM VALIDATION RESULTS</i>	11
9. PROBE MODULATION FACTOR (PMF)	12
9.1. <i>PMF RESULTS FOR WCDMA</i>	14
10. HAC RF EMISSIONS TEST PROCEDURE	15
11. RF EMISSIONS MEASUREMENT CRITERA	17
12. SUMMARY OF TEST RESULTS	18
12.1. <i>E-FIELD EMISSIONS</i>	18
12.2. <i>H-FIELD EMISSIONS</i>	18
13. WORST-CAST TEST PLOTS	19
14. ATTACHMENTS	23
15. TEST SETUP PHOTO	24

1. ATTESTATION OF TEST RESULTS

Applicant name:	Apple Inc. 1 Infinite Loop, MS-26A Cupertino, CA 95014-2084
EUT description:	iPhone
Model number:	A1349
Device category:	Portable
Exposure category:	General Population/Uncontrolled Exposure
Date of tested:	November 12 – 15, 2010
Maximum E/H-Filed Emissions	
Max. E-Field emissions:	Part 22 - Cellular band: 76.9 V/m (M4) Part 24 - PCS band: 46.7 V/m (M4)
Max. H-Field emissions:	Part 22 - Cellular band: 0.141 A/m (M4) Part 24 - PCS band: 0.139 A/m (M4)
Hearing Aid Near-Field Category: M4 (Part 22), M4 (Part 22),	

Applicable Standards	Test Results
ANSI C63.19-2007	Part 22 - Pass Part 24 – Pass

Compliance Certification Services, Inc. (UL CCS) tested the above equipment in accordance with the requirements set forth in the above standards. All indications of Pass/Fail in this report are opinions expressed by UL CCS based on interpretations and/or observations of test results. Measurement Uncertainties were not taken into account and are published for informational purposes only. The test results show that the equipment tested is capable of demonstrating compliance with the requirements as documented in this report.

Note: The results documented in this report apply only to the tested sample, under the conditions and modes of operation as described herein. This document may not be altered or revised in any way unless done so by UL CCS and all revisions are duly noted in the revisions section. Any alteration of this document not carried out by UL CCS will constitute fraud and shall nullify the document. This report must not be used by the client to claim product certification, approval, or endorsement by NVLAP, NIST, any agency of the Federal Government, or any agency of any government (NIST Handbook 150, Annex A). This report is written to support regulatory compliance of the applicable standards stated above.

Approved & Released For UL CCS By:

Tested By:

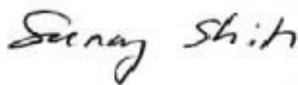

Sunny Shih
 Engineering Team Leader
 Compliance Certification Services (UL CCS)

Devin Chang
 EMC Engineer
 Compliance Certification Services (UL CCS)

2. TEST METHODOLOGY

The tests documented in this report were performed in accordance with ANSI C63.19-2007 Methods of Measurement of Compatibility between Wireless Communications Devices and Hearing Aids and FCC KDB 285076 D01 HAC Guidance v01r01

3. FACILITIES AND ACCREDITATION

The test sites and measurement facilities used to collect data are located at 47173 Benicia Street, Fremont, California, USA.

UL CCS is accredited by NVLAP, Laboratory Code 200065-0. The full scope of accreditation can be viewed at <http://www.ccsemc.com>.

4. CALIBRATION AND UNCERTAINTY

4.1. MEASURING INSTRUMENT CALIBRATION

The measuring equipment utilized to perform the tests documented in this report has been calibrated in accordance with the manufacturer's recommendations, and is traceable to recognized national standards.

<u>Name of Equipment</u>	<u>Manufacturer</u>	<u>Type/Model</u>	<u>Serial Number</u>	<u>Cal. Due date</u>
Robot - Six Axes	Stäubli	RX90BL	N/A	N/A
Robot Remote Control	Stäubli	CS7MB	3403-91535	N/A
DASY4 Measurement Server	SPEAG	SEUMS001BA	1041	N/A
Probe Alignment Unit	SPEAG	LB (V2)	261	N/A
Data Acquisition Electronics	SPEAG	DAE3	427	7/21/11
E-Field Probe	SPEAG	ER3DV6	2339	2/16/11
H-Field Probe	SPEAG	H3DV6	6157	2/16/11
Calibration Dipole	SPEAG	CD1880V3	1010	2/11/11
Calibration Dipole	SPEAG	CD835V3	1014	2/11/11
Power Meter	Giga-Tronics	8651A	8651404	5/13/12
Power Sensor	Giga-Tronics	80701A	1834588	5/13/12
Amplifier	Mini-Circuits	ZHL-42W	D072701-5	N/A
Radio Communication Tester	R & S	CMU 200	106291	11/27/10

4.2. MEASUREMENT UNCERTAINTY

HAC Uncertainty Budget According to ANSI PC63.19

Error Description	Uncertainty value ($\pm\%$)	Probe Dist.	Div.	(Ci) E	(Ci) H	Std. Unc.($\pm\%$)	
						E	H
Measurement System							
Probe Calibration	5.10	N	1	1	1	5.1	5.1
Axial Isotropy	4.70	R	1.732	1	1	2.7	2.7
Sensor Displacement	16.50	R	1.732	1	0.145	9.5	1.4
Boundary Effects	2.40	R	1.732	1	1	1.4	1.4
Linearity	4.70	R	1.732	1	1	2.7	2.7
Scaling to Peak Envelope Power	2.00	R	1.732	1	1	1.2	1.2
System Detection Limit	1.00	R	1.732	1	1	0.6	0.6
Readout Electronics	0.30	N	1	1	1	0.3	0.3
Response Time	0.80	R	1.732	1	1	0.5	0.5
Integration Time	2.60	R	1.732	1	1	1.5	1.5
RF Ambient Conditions	3.00	R	1.732	1	1	1.7	1.7
RF Reflections	12.00	R	1.732	1	1	6.9	6.9
Probe Positioner	1.20	R	1.732	1	0.67	0.7	0.5
Probe Positioning	4.70	R	1.732	1	0.67	2.7	1.8
Extrapolation and Interpolation	1.00	R	1.732	1	1	0.6	0.6
Test sample Related							
Test Positioning Vertical	4.70	R	1.732	1	0.67	2.7	1.8
Test Positioning Lateral	1.00	R	1.732	1	1	0.6	0.6
Device Holder and Phantom	2.40	R	1.732	1	1	1.4	1.4
Power Drift	5.00	R	1.732	1	1	2.9	2.9
Phantom and Setup Related							
Phantom Thickness	2.40	R	1.732	1	0.67	1.4	0.9
Combined Std. Uncertainty						14.7	10.9
Expanded Std. Uncertainty on Power						29.4	21.8
Expanded Std. Uncertainty on Field						14.7	10.9
Notes for table							
1. N - Nomal							
2. R - Rectangular							
3. Div. - Divisor used to obtain standard uncertainty							
4. Ci - is te sensitivity coefficient							

5. EQUIPMENT UNDER TEST

iPhone with 802.11bgn and Bluetooth radio modules. Model number: A1349 with Murata WiFi module	
Normal operation:	Held to head, Worn on body (LCD facing-up and LCD facing-down) with 15 mm separation distance.
Body Worn Accessory	Headset
Antenna-to-antenna separation distances:	8.7 cm from WWAN main antenna-to-WiFi/BT main antenna
Simultaneous transmission:	- 3G can transmit simultaneously with WiFi - 3G can transmit simultaneously with Bluetooth - WiFi can not transmit simultaneously with Bluetooth

6. LIST OF AIR INTERFACES/BANDS & OPERATING MODES

Air-interface	Bands (MHz)	Type	C63.19/ Tested	Simultaneous Transmissions	Concurrent Single Transmission	Reduced power 20.19 (c) (1)	Voice Over Digital Transport (Data)
CDMA	850	VO	Yes	Yes WiFi or Bluetooth	No: Ev-Do, WiFi	No	N/A
	1900	VO	Yes			No	N/A
	EV-Do	DT	N/A	N/A	No	No	Yes
WiFi	2400	DT	NA	CDMA	NA	NA	Yes
	5000	DT	NA	CDMA	NA	NA	Yes
Bluetooth	2400	DT	NA	CDMA	NA	NA	Yes
VO Voice CMRS/PSTN Service Only V/D Voice CMRS/PSTN and Data Service DT Digital Transport				*HAC rating was not based on concurrent voice and data modes, Non current mode was found to represent worst case rating for both M and T rating.			

7. SYSTEM SPECIFICATIONS

E-field and H-field measurements are performed using the DASY4 automated dosimetric assessment system. The DASY4 is made by Schmid & Partner Engineering AG (SPEAG) in Zurich, Switzerland.

The DASY4 HAC Extension consists of the following parts:

Test Arch Phantom

The specially designed Test Arch allows high precision positioning of both the device and any of the validation dipoles.

ER3DV6 Isotropic E-Field Probe

Construction:	One dipole parallel, two dipoles normal to probe axis Built-in shielding against static charges PEEK enclosure material (resistant to organic solvents, e.g., glycoether)
Calibration:	In air from 100 MHz to 3.0 GHz (absolute accuracy $\pm 6.0\%$, $k=2$)
Frequency:	100 MHz to > 6 GHz; Linearity: ± 0.2 dB (100 MHz to 3 GHz)
Directivity:	± 0.2 dB in air (rotation around probe axis) ± 0.4 dB in air (rotation normal to probe axis)
Dynamic Range:	2 V/m to > 1000 V/m; Linearity: ± 0.2 dB
Dimensions:	Overall length: 330 mm (Tip: 16 mm) Tip diameter: 8 mm (Body: 12 mm) Distance from probe tip to dipole centers: 2.5 mm The closest part of the sensor element is 1.1 mm closer to the tip
Application:	General near-field measurements up to 6 GHz Field component measurements

H3DV6 3-Dimensional H-Field Probe

Construction:	Three concentric loop sensors with 3.8 mm loop diameters resistively loaded detector diodes for linear response Built-in shielding against static charges PEEK enclosure material (resistant to organic solvents, e.g., glycoether)
Frequency:	200 MHz to 3 GHz (absolute accuracy $\pm 6.0\%$, $k=2$); Output linearized
Directivity:	± 0.25 dB (spherical isotropy error)
Dynamic Range:	10 mA/m to 2 A/m at 1 GHz
E-Field Interference:	< 10% at 3 GHz (for plane wave)
Dimensions:	Overall length: 330 mm (Tip: 40 mm) Tip diameter: 6 mm (Body: 12 mm) Distance from probe tip to dipole centers: 3 mm The closest part of the sensor element is 1.9 mm closer to the tip
Application:	General magnetic near-field measurements up to 3 GHz Field component measurements Surface current measurements Measurements in air or liquids Low interaction with the measured field

8. SYSTEM VALIDATION

The test setup was validated when first configured and verified periodically thereafter to ensure proper function. The procedure provided in this section is a validation procedure using dipole antennas for which the field levels were computed by numeric modeling.

Procedure

Place a dipole antenna meeting the requirements given in ANSI-PC63.19 2007 in the normally occupied by the WD.

The dipole antenna serves as a known source for an electrical and magnetic output. Position the E-field and H-field probes so that:

- The probes and their cables are parallel to the coaxial feed of the dipole antenna
- The probe cables and the coaxial feed of the dipole antenna approach the measurement area from opposite directions; and
- The center point of the probe element(s) are 10 mm from the closest surface of the dipole elements.

Scan the length of the dipole with both E-field and H-field probes and record the maximum values for each. Compare the readings to expected values.

Setup diagram

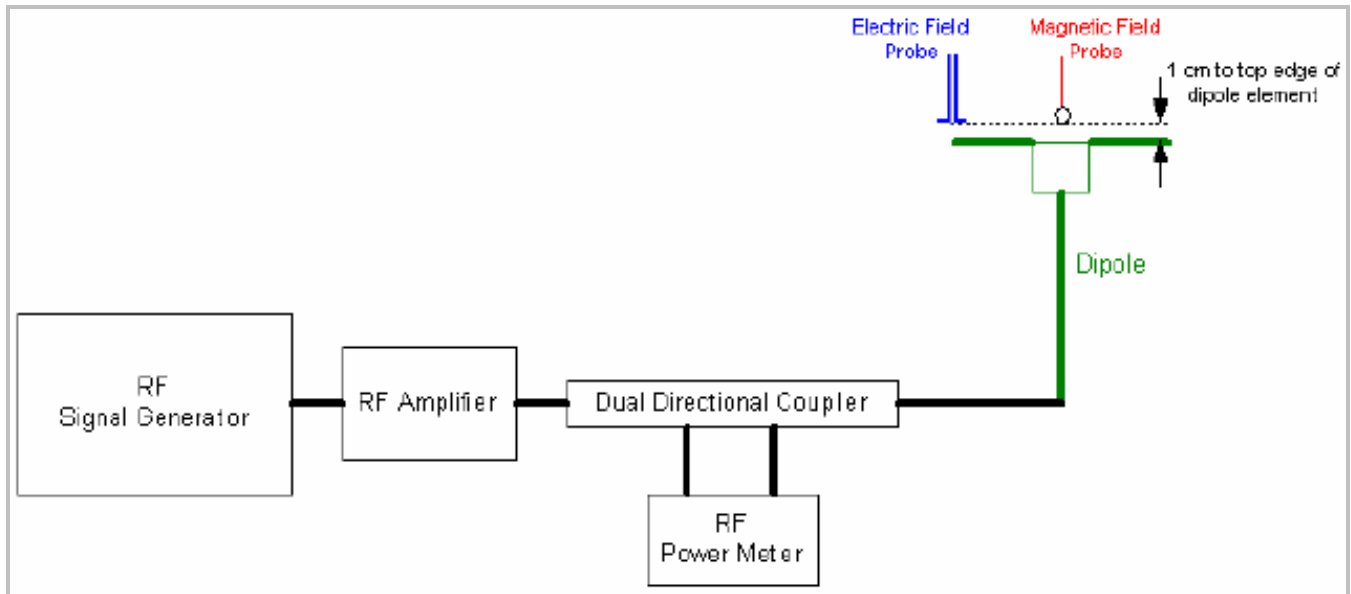

8.1. SYSTEM VALIDATION RESULTS

E-field

Calibration Dipole	f (MHz)	Input Power (mW)	Max. measured from		Average max. above arm (V/m)	E-field Target Values (V/m) (From SPEAG)	Deviation ¹⁾ (%)
			above high end (V/m)	above low end (V/m)			
CD835V3 SN 1014	835	100	162.1	154.4	158.25	162.5	-2.62
CD1880V3 SN 1010	1880	100	134.9	129.10	132.00	137.2	-3.79

H-field

Calibration Dipole	f (MHz)	Input Power (mW)	Measured H-field (A/m)	H-field Target Values (A/m) (From SPEAG)	Deviation ¹⁾ (%)
CD835V3 SN 1014	835	100	0.458	0.450	1.78
CD1880V3 SN 1010	1880	100	0.456	0.467	-2.36

Notes:

- 1) Delta (Deviation) % = 100 * (Measured value minus Target value) divided by the Target value.
Deltas within ±25% are acceptable, of which 12% is deviation and 13% is measurement uncertainty.
- 2) The maximum E-field or H-field were evaluated and compared to the target values provided by SPEAG in the calibration certificate of specific dipoles.
- 3) Please refer to the attachment for detailed measurement data and plots.

9. PROBE MODULATION FACTOR (PMF)

Purpose

The HAC Standard requires measurement of the peak envelope E- and H-fields of the wireless device (WD). Para. 4.2.2.1, and C.3.1 of the standard describes the Probe Modulation Response Factor that shall be applied to convert the probe reading to Peak Envelope Field.

Definitions

The Probe Modulation Factor (PMF) is defined as the ratio of the field readings for a CW and a modulated signal with the equivalent Field Envelope Peak as defined in the Standard (Chapter C.3.1).

Evaluation Procedure for Unknown PMF (DASY4 Application note, Section 28.8)

The proposed measurement setup corresponds to the procedure as required in the Standard, Chapter C.3.1.

1. Install a calibration dipole for the appropriate frequency band under the Test Arch Phantom and select the proper phantom section according to the probe type installed (E- or H-field). Move the probe to the field reference point. (Do not move the probe between the subsequent CW and modulated measurements.)
2. Install the field probe in the setup.
3. The modulated signal to the dipole must be monitored to record peak amplitude and compared to a CW signal with the same peak envelope level (e.g., with a directional coupler and a spectrum analyzer in zero span mode set to the operating frequency). To determine the peak envelope level of the modulated signal properly, the settings of a spectrum analyzer shall be as follows:
 - Resolution bandwidth \geq emission bandwidth (4 MHz for UMTS bands, 300 kHz)
 - Video bandwidth \geq 20 kHz
 - Span: zero
 - Center Frequency: nominal center frequency of channel
 - Detection: RMS detection with averaging turned on
 - Trigger: Video or IF trigger, adjusted to give a stable display of the transmission
 - Sweep rate: Sufficiently rapid to permit the transmit pulse to be resolved accurately. The sweep shall be long enough to show a complete transmission. The sweep time may be set to allow a full transmission cycle, displaying the on and off time.
4. Define a DASY4 document and set the procedure properties (frequency, modulation frequency and crest factor) according to the measured signal. Define a multimeter job for the field reading.
5. Define a second procedure for the evaluation of the CW signal (frequency set as above, modulation frequency = 0, crest factor = 1) and a multimeter job.

PMF Measurement Setup Diagram

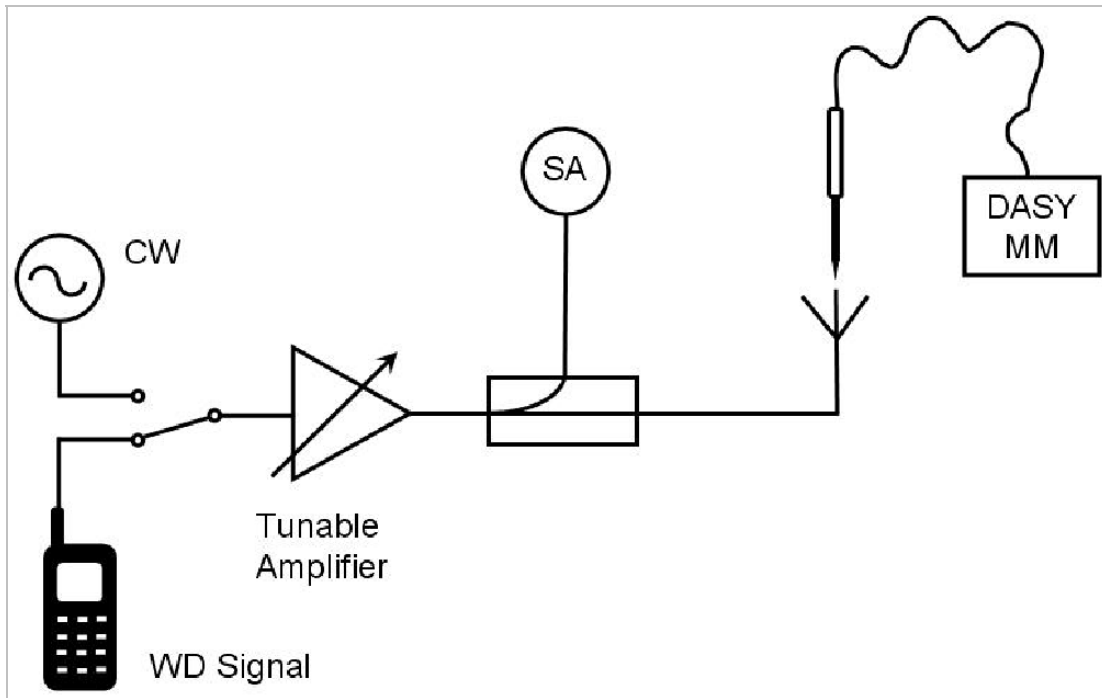

The HAC measurement procedure is as follows:

- a) Modulated signals (WD and 80% AM) measurement:
 - 1) Connect the modulated signal using the appropriate frequency via the cable to the dipole.
 - 2) The signal to the dipole must be monitored to record peak amplitude with a directional coupler and a spectrum analyzer.
 - 3) Run the multimeter job in the procedure with the corresponding modulation setting in continuous mode.
 - 4) Read the envelope peak on the monitor in order to adjust the CW signal later to the same level.
- b) CW signal measurement:
 - 1) Change the signal to CW at the same center frequency, without touching or moving the dipole and probe in the setup.
 - 2) Adjust the CW signal amplitude to the same peak level on the spectrum analyzer (keep the same bandwidth and attenuation for CW and modulated signals).
 - 3) Run the multimeter job in the CW procedure in continuous mode.
 - 4) Read the multimeter total field display and note it together with modulation type and frequency.
 - 5) Calculate the Probe Modulation Factor as the ratio between the CW multimeter field reading and the reading for the applicable modulation. I.e., $PMF = \frac{E_{cw}}{E_{mod}}$ and similar for H.

9.1. PMF RESULTS FOR WCDMA

Probe	Frequency (MHz)	Type of signal	E-field V/m	PMF
E-Field Probe	835	CDMA	57.82	1.00
		CW	57.77	
	1880	CDMA	60.1	1.00
		CW	60.3	
Probe	Frequency (MHz)	Type of signal	H-field A/m	PMF
H-Field Probe	835	CDMA	0.24	1.00
		CW	0.24	
	1880	CDMA	0.229	0.99
		CW	0.227	

10. HAC RF EMISSIONS TEST PROCEDURE

The following are step-by-step test procedures.

1. Confirm proper operation of the field probe, probe measurement system and other instrumentation and the positioning system.
2. Position the WD in its intended test position.
3. Configure the WD normal operation for maximum rated RF output power, at the desired channel and other operating parameters, (e.g. test mode) as intended for the test.
4. The center sub-grid shall be centered on the center of the WD output (acoustic or T-coil output), as appropriate. Locate the field probe at the initial test position in the 5 x 5 cm grid, which is contained in the measurement plane, see illustrated in Figure 5.
5. Record the reading.
6. Scan the entire 5 x 5 cm region in equally spaced increments and record the reading at each measurement point. The distance between measurement points shall be sufficient to assure the identification of the peak reading.
7. Identify the five contiguous sub-grids around the center sub-grid with the lowest maximum strength readings. Thus the 6 areas to be used to determine the WD's peak emissions are identified and outlined for the final manual scan. Please note that a maximum of five blocks can be excluded for both E- and H-field measurements for the WD output being measured. State another way, the center sub-grid and 3 other must be common to both the E- and H-field measurements.
8. Identify the highest field reading within the non-excluded sub-grids identified in step 7.
9. Convert the highest field reading within identified in step 8 to peak V/m or A/m, as appropriate.
10. Repeat steps 1-10 for both the E- and H-field measurements.
11. Compare this reading to the categories in ANSI-PC63.19 and record the resulting category. The lowest category number listed in ANSI-PC63.19 obtained in step 10 for either E or H field determines the M category for the audio coupling mode assessment. Record the WD category rating.

Test flowchart Per ANSI-PC63.19 2007

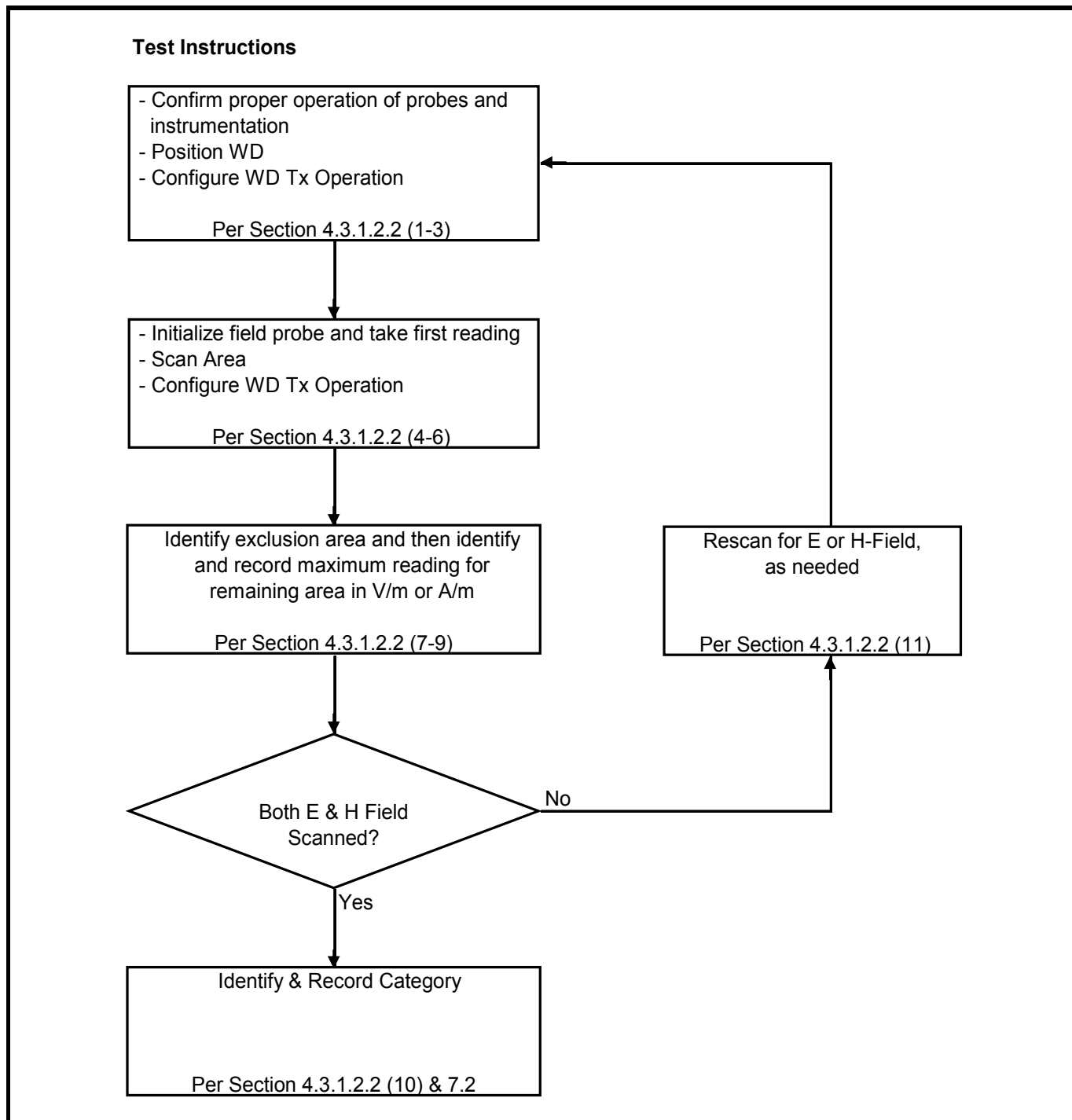

11. RF EMISSIONS MEASUREMENT CRITERA

Telephone near-field Categories in linear units

		Telephone RF Parameters			
		< 960 MHz		> 960 MHz	
Category	AWF	E-Field Emissions (V/m)	H-Field Emissions (A/m)	E-Field Emissions (V/m)	H-Field Emissions (A/m)
M3	0	199.5 to 354.8	0.60 to 1.07	63.1 to 112.2	0.19 to 0.34
	-5	149.6 to 266.1	0.45 to 0.80	47.3 to 84.1	0.14 to 0.25
M4	0	< 199.5	< 0.60	< 63.1	< 0.19
	-5	< 149.6	< 0.45	< 47.3	< 0.14

12. SUMMARY OF TEST RESULTS

Notes: The WiFi and Bluetooth off during HAC testing and run in a radiated environment.

12.1. E-FIELD EMISSIONS

Operating Mode	Ch. No.	f (MHz)	PMF	Peak E-Field (V/m)	M-Rating
Cell Band 1xRTT (RC3, SO55)	1013	824.70	1.00	69.9	M4
	384	836.52		72.6	M4
	777	848.31		76.9	M4
PCS Band 1xRTT (RC3, SO55)	25	1851.25	1.00	46.7	M4
	600	1880.00		44.8	M4
	1175	1908.75		39.1	M4

12.2. H-FIELD EMISSIONS

Operating Mode	Ch. No.	f (MHz)	PMF	Peak H-Field (A/m)	M-Rating
Cell Band 1xRTT (RC3, SO55)	1013	824.70	1.00	0.123	M4
	384	836.52		0.134	M4
	777	848.31		0.141	M4
PCS Band 1xRTT (RC3, SO55)	25	1851.25	0.99	0.138	M4
	600	1880.00		0.139	M4
	1175	1908.75		0.127	M4

13. WORST-CAST TEST PLOTS

E-field worst-cast test plot for Part 22

Date/Time: 11/12/2010 3:57:06 PM

Test Laboratory: Compliance Certification Services

Cell Band_HAC (Murata)

DUT: Apple; Type: N/A; Serial: N/A

Communication System: CDMA Cell Band; Frequency: 848.31 MHz; Duty Cycle: 1:1
 Medium parameters used: $\sigma = 0$ mho/m, $\epsilon_r = 1$; $\rho = 1000$ kg/m³
 Phantom section: RF Section

DASY4 Configuration:

- Probe: ER3DV6 - SN2339; ConvF(1, 1, 1); Calibrated: 2/16/2010
- Sensor-Surface: (Fix Surface)
- Electronics: DAE3 Sn427; Calibrated: 7/21/2010
- Phantom: HAC Test Arch with AMCC; Type: SD HAC P01 BA; Serial: 100x
- Measurement SW: DASY4, V4.7 Build 80; Postprocessing SW: SEMCAD, V1.8 Build 186

E Scan - H-ch/Hearing Aid Compatibility Test (101x101x1): Measurement grid: dx=5mm, dy=5mm

Maximum value of peak Total field = 76.9 V/m
 Probe Modulation Factor = 1.00
 Device Reference Point: 0.000, 0.000, -6.30 mm
 Reference Value = 78.3 V/m; Power Drift = -0.033 dB

Hearing Aid Near-Field Category: M4 (AWF 0 dB)

Peak E-field in V/m

Grid 1 67.2 M4	Grid 2 79.5 M4	Grid 3 79.5 M4
Grid 4 58.6 M4	Grid 5 76.9 M4	Grid 6 78.3 M4
Grid 7 49.2 M4	Grid 8 69.2 M4	Grid 9 71.6 M4

Cursor:

Total = 79.5 V/m
 E Category: M4
 Location: -8.5, -23.5, 8.7 mm

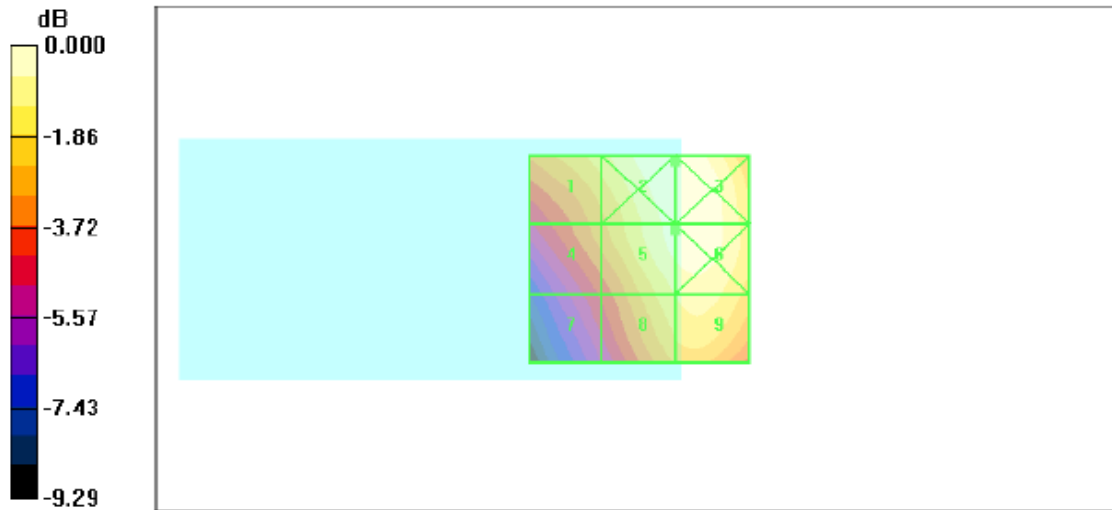

E-field worst-cast test plot for Part 24

Date/Time: 11/15/2010 2:13:52 PM

Test Laboratory: Compliance Certification Services

PCS Band_HAC (Murata)

DUT: Apple; Type: N/A; Serial: N/A

Communication System: CDMA PCS Band; Frequency: 1851.25 MHz; Duty Cycle: 1:1

Medium parameters used: $\sigma = 0$ mho/m, $\epsilon_r = 1$; $\rho = 1000$ kg/m³

Phantom section: RF Section

DASY4 Configuration:

- Probe: ER3DV6 - SN2339; ConvF(1, 1, 1); Calibrated: 2/16/2010
- Sensor-Surface: (Fix Surface)
- Electronics: DAE3 Sn427; Calibrated: 7/21/2010
- Phantom: HAC Test Arch with AMCC; Type: SD HAC P01 BA; Serial: 100x
- Measurement SW: DASY4, V4.7 Build 80; Postprocessing SW: SEMCAD, V1.8 Build 186

E Scan - L-ch/Hearing Aid Compatibility Test (101x101x1): Measurement grid: dx=5mm, dy=5mm

Maximum value of peak Total field = 46.7 V/m

Probe Modulation Factor = 1.00

Device Reference Point: 0.000, 0.000, -6.30 mm

Reference Value = 36.5 V/m; Power Drift = -0.026 dB

Hearing Aid Near-Field Category: M4 (AWF 0 dB)

Peak E-field in V/m

Grid 1 49.4 M4	Grid 2 42.4 M4	Grid 3 45.7 M4
Grid 4 42.3 M4	Grid 5 43.3 M4	Grid 6 46.7 M4
Grid 7 38.1 M4	Grid 8 41.1 M4	Grid 9 45.0 M4

Cursor:

Total = 49.4 V/m

E Category: M4

Location: 25, -25, 8.7 mm

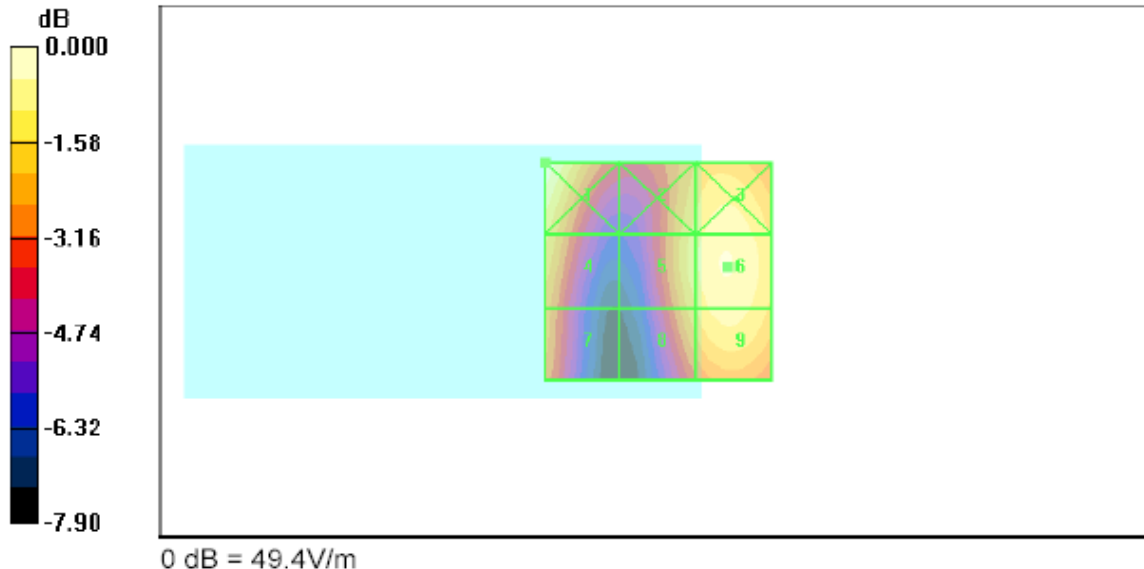

H-field worst-cast test plot for Part 22

Date/Time: 11/12/2010 3:45:59 PM

Test Laboratory: Compliance Certification Services

Cell Band_HAC (Murata)

DUT: Apple; Type: N/A; Serial: N/A

Communication System: CDMA Cell Band; Frequency: 848.31 MHz; Duty Cycle: 1:1
 Medium parameters used: $\sigma = 0$ rho/m, $\epsilon_r = 1$; $\rho = 1$ kg/m³
 Phantom section: RF Section

DASY4 Configuration:

- Probe: H3DV6 - SN6157; ; Calibrated: 2/16/2010
- Sensor-Surface: (Fix Surface)
- Electronics: DAE3 Sn427; Calibrated: 7/21/2010
- Phantom: HAC Test Arch with AMCC; Type: SD HAC P01 BA; Serial: 100x
- Measurement SW: DASY4, V4.7 Build 80; Postprocessing SW: SEMCAD, V1.8 Build 186

H Scan - H-ch/Hearing Aid Compatibility Test (101x101x1): Measurement grid: dx=5mm, dy=5mm

Maximum value of peak Total field = 0.141 A/m
 Probe Modulation Factor = 1.00
 Device Reference Point: 0.000, 0.000, -6.30 mm
 Reference Value = 0.149 A/m; Power Drift = -0.049 dB

Hearing Aid Near-Field Category: M4 (AWF 0 dB)

Peak H-field in A/m

Grid 1 0.175 M4	Grid 2 0.141 M4	Grid 3 0.103 M4
Grid 4 0.167 M4	Grid 5 0.140 M4	Grid 6 0.112 M4
Grid 7 0.168 M4	Grid 8 0.137 M4	Grid 9 0.112 M4

Cursor:

Total = 0.175 A/m
 H Category: M4
 Location: 25, -25, 8.7 mm

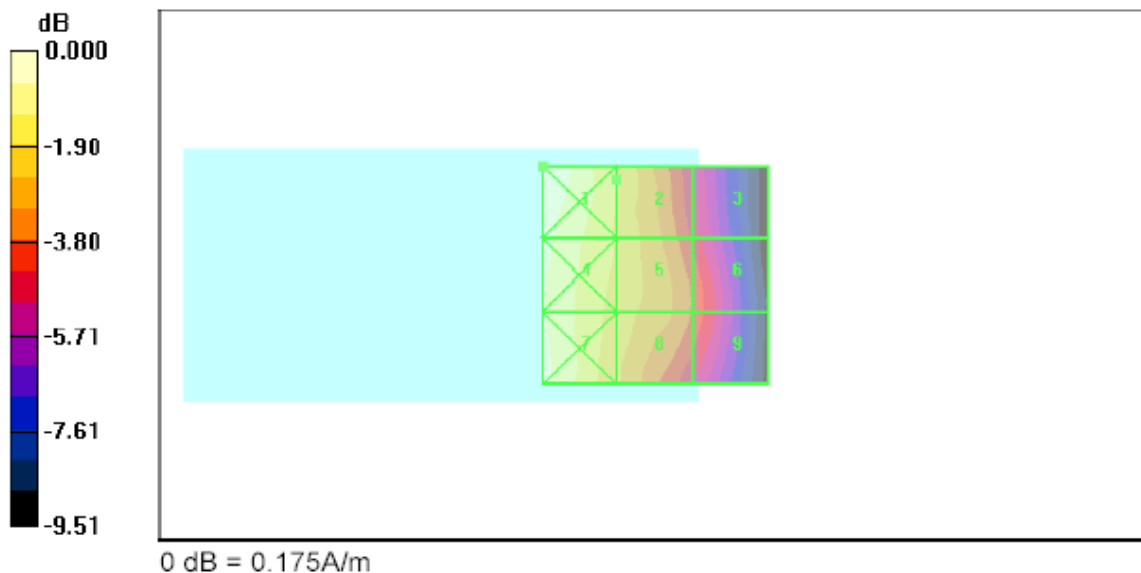

H-field worst-cast test plot for Part 24

Date/Time: 11/15/2010 1:30:19 PM

Test Laboratory: Compliance Certification Services

PCS Band_HAC (Murata)

DUT: Apple; Type: N/A; Serial: N/A

Communication System: CDMA PCS Band; Frequency: 1880 MHz; Duty Cycle: 1:1
 Medium parameters used: $\sigma = 0$ mho/m, $\epsilon_r = 1$; $\rho = 1$ kg/m³
 Phantom section: RF Section

DASY4 Configuration:

- Probe: H3DV6 - SN6157; ; Calibrated: 2/16/2010
- Sensor-Surface: (Fix Surface)
- Electronics: DAE3 Sn427; Calibrated: 7/21/2010
- Phantom: HAC Test Arch with AMCC; Type: SD HAC P01 BA; Serial: 100x
- Measurement SW: DASY4, V4.7 Build 80; Postprocessing SW: SEMCAD, V1.8 Build 186

H Scan - M-ch/Hearing Aid Compatibility Test (101x101x1): Measurement grid: dx=5mm, dy=5mm

Maximum value of peak Total field = 0.139 A/m
 Probe Modulation Factor = 0.990
 Device Reference Point: 0.000, 0.000, -6.30 mm
 Reference Value = 0.156 A/m; Power Drift = -0.080 dB

Hearing Aid Near-Field Category: M4 (AWF 0 dB)

Peak H-field in A/m

Grid 1 0.133 M4	Grid 2 0.140 M4	Grid 3 0.131 M4
Grid 4 0.133 M4	Grid 5 0.139 M4	Grid 6 0.130 M4
Grid 7 0.130 M4	Grid 8 0.133 M4	Grid 9 0.126 M4

Cursor:
 Total = 0.140 A/m
 H Category: M4
 Location: 0, -13.5, 8.7 mm

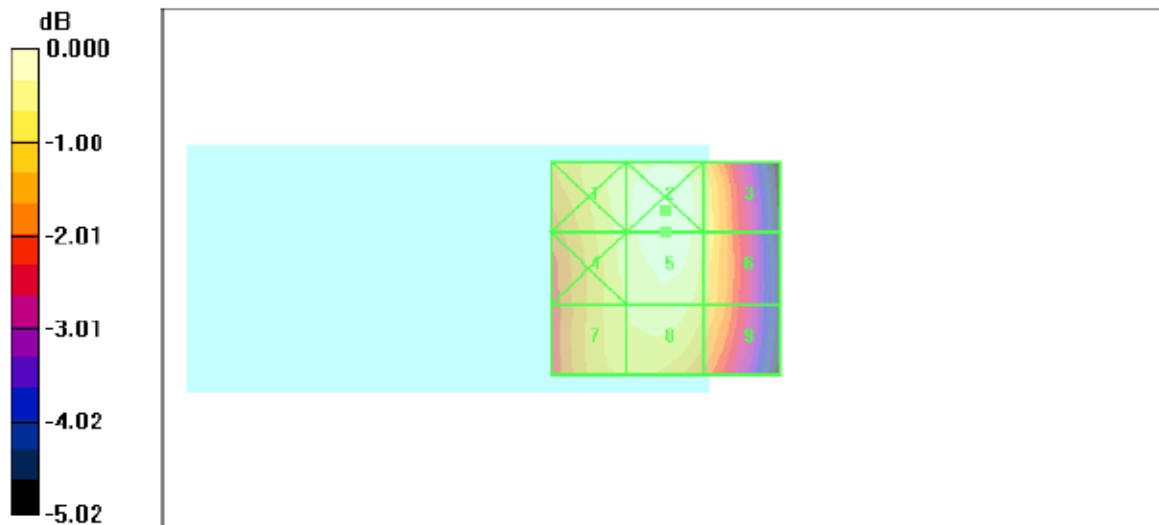

0 dB = 0.140A/m

14. ATTACHMENTS

<u>No.</u>	<u>Contents</u>	<u>No. of page (s)</u>
1	System Validation Plots	4
2	E&H-field emissions test plots for Murata antenna	12
3	Certificate of E-Field Probe - ER3DV6 SN 2339	10
4	Certificate of H-Field Probe - H3DV6 SN 6157	10
5	Certificate of Dipole CD1880V3 - SN 1010	6
6	Certificate of Dipole CD835V3 - SN 1014	6