

# FCC Radio Test Report

## FCC ID: APIJBLT450BT

This report concerns (check one):  Original Grant  Class I Change  Class II Change

**Project No.** : 1607C092  
**Equipment** : Wireless Headphone  
**Model Name** : T450BT  
**Applicant** : Harman International Industries, Incorporated  
**Address** : 8500 Balboa Blvd, Northridge, CA 91329, UNITED STATES

**Date of Receipt** : Jul. 15, 2016  
**Date of Test** : Jul. 15, 2016 ~ Jul. 28, 2016  
**Issued Date** : Jul. 29, 2016  
**Tested by** : BTL Inc.

**Testing Engineer** : Shawn Xiao  
(Shawn Xiao)

**Technical Manager** : David Mao  
(David Mao)

**Authorized Signatory** : Steven Lu  
(Steven Lu)

# **B T L I N C .**

No.3, Jinshagang 1st Road, Shixia, Dalang Town, Dongguan,  
Guangdong, China.

TEL: +86-769-8318-3000 FAX: +86-769-8319-6000

**Declaration**

**BTL** represents to the client that testing is done in accordance with standard procedures as applicable and that test instruments used has been calibrated with standards traceable to international standard(s) and/or national standard(s).

**BTL's** reports apply only to the specific samples tested under conditions. It is manufacture's responsibility to ensure that additional production units of this model are manufactured with the identical electrical and mechanical components. **BTL** shall have no liability for any declarations, inferences or generalizations drawn by the client or others from **BTL** issued reports.

**BTL's** report must not be used by the client to claim product certification, approval, or endorsement by NVLAP, NIST, or any agency of the Federal Government.

This report is the confidential property of the client. As a mutual protection to the clients, the public and **BTL-self**, extracts from the test report shall not be reproduced except in full with **BTL's** authorized written approval.

**BTL's** laboratory quality assurance procedures are in compliance with the **ISO Guide 17025** requirements, and accredited by the conformity assessment authorities listed in this test report.

**Limitation**

For the use of the authority's logo is limited unless the Test Standard(s)/Scope(s)/Item(s) mentioned in this test report is (are) included in the conformity assessment authorities acceptance respective.

<b>Table of Contents</b>	<b>Page</b>
<b>1 . CERTIFICATION</b>	<b>7</b>
<b>2 . SUMMARY OF TEST RESULTS</b>	<b>8</b>
2.1 TEST FACILITY	9
2.2 MEASUREMENT UNCERTAINTY	9
<b>3 . GENERAL INFORMATION</b>	<b>10</b>
3.1 GENERAL DESCRIPTION OF EUT	10
3.2 DESCRIPTION OF TEST MODES	12
3.3 TABLE OF PARAMETERS OF TEXT SOFTWARE SETTING	12
3.4 BLOCK DIAGRAM SHOWING THE CONFIGURATION OF SYSTEM TESTED	13
3.5 DESCRIPTION OF SUPPORT UNITS	13
<b>4 . EMC EMISSION TEST</b>	<b>14</b>
4.1 CONDUCTED EMISSION MEASUREMENT	14
4.1.1 POWER LINE CONDUCTED EMISSION LIMITS	14
4.1.2 TEST PROCEDURE	14
4.1.3 DEVIATION FROM TEST STANDARD	14
4.1.4 TEST SETUP	15
4.1.5 EUT OPERATING CONDITIONS	15
4.1.6 EUT TEST CONDITIONS	15
4.1.7 TEST RESULTS	15
4.2 RADIATED EMISSION MEASUREMENT	16
4.2.1 RADIATED EMISSION LIMITS	16
4.2.2 TEST PROCEDURE	17
4.2.3 DEVIATION FROM TEST STANDARD	17
4.2.4 TEST SETUP	18
4.2.5 EUT OPERATING CONDITIONS	19
4.2.6 EUT TEST CONDITIONS	19
4.2.7 TEST RESULTS (9KHZ TO 30MHZ)	19
4.2.8 TEST RESULTS (30MHZ TO 1000 MHZ)	20
4.2.9 TEST RESULTS (ABOVE 1000 MHZ)	20
<b>5 . NUMBER OF HOPPING CHANNEL</b>	<b>21</b>
5.1 APPLIED PROCEDURES	21
5.1.1 TEST PROCEDURE	21
5.1.2 DEVIATION FROM STANDARD	21
5.1.3 TEST SETUP	21
5.1.4 EUT OPERATION CONDITIONS	21
5.1.5 EUT TEST CONDITIONS	21
5.1.6 TEST RESULTS	21

Table of Contents	Page
<b>6 . AVERAGE TIME OF OCCUPANCY</b>	<b>22</b>
<b>6.1 APPLIED PROCEDURES / LIMIT</b>	<b>22</b>
6.1.1 TEST PROCEDURE	22
6.1.2 DEVIATION FROM STANDARD	22
6.1.3 TEST SETUP	22
6.1.4 EUT OPERATION CONDITIONS	23
6.1.5 EUT TEST CONDITIONS	23
6.1.6 TEST RESULTS	23
<b>7 . HOPPING CHANNEL SEPARATION MEASUREMENT</b>	<b>24</b>
<b>7.1 APPLIED PROCEDURES / LIMIT</b>	<b>24</b>
7.1.1 TEST PROCEDURE	24
7.1.2 DEVIATION FROM STANDARD	24
7.1.3 TEST SETUP	24
7.1.4 EUT TEST CONDITIONS	24
7.1.5 TEST RESULTS	24
<b>8 . BANDWIDTH TEST</b>	<b>25</b>
<b>8.1 APPLIED PROCEDURES</b>	<b>25</b>
8.1.1 TEST PROCEDURE	25
8.1.2 DEVIATION FROM STANDARD	25
8.1.3 TEST SETUP	25
8.1.4 EUT OPERATION CONDITIONS	25
8.1.5 EUT TEST CONDITIONS	25
8.1.6 TEST RESULTS	25
<b>9 . PEAK OUTPUT POWER TEST</b>	<b>26</b>
<b>9.1 APPLIED PROCEDURES / LIMIT</b>	<b>26</b>
9.1.1 TEST PROCEDURE	26
9.1.2 DEVIATION FROM STANDARD	26
9.1.3 TEST SETUP	26
9.1.4 EUT OPERATION CONDITIONS	26
9.1.5 EUT TEST CONDITIONS	26
9.1.6 TEST RESULTS	26
<b>10 . ANTENNA CONDUCTED SPURIOUS EMISSION</b>	<b>27</b>
<b>10.1 APPLIED PROCEDURES / LIMIT</b>	<b>27</b>
10.1.1 TEST PROCEDURE	27
10.1.2 DEVIATION FROM STANDARD	27
10.1.3 TEST SETUP	27
10.1.4 EUT OPERATION CONDITIONS	27
10.1.5 EUT TEST CONDITIONS	27
10.1.6 TEST RESULTS	27
<b>11 . MEASUREMENT INSTRUMENTS LIST</b>	<b>28</b>

<b>Table of Contents</b>	<b>Page</b>
<b>12 . EUT TEST PHOTO</b>	<b>30</b>
<b>ATTACHMENT A - CONDUCTED EMISSION</b>	<b>34</b>
<b>ATTACHMENT B - RADIATED EMISSION (9KHZ-30MHZ)</b>	<b>37</b>
<b>ATTACHMENT C - RADIATED EMISSION (30MHZ TO 1000MHZ)</b>	<b>39</b>
<b>ATTACHMENT D - RADIATED EMISSION (ABOVE 1000MHZ)</b>	<b>46</b>
<b>ATTACHMENT E - NUMBER OF HOPPING CHANNEL</b>	<b>71</b>
<b>ATTACHMENT F - AVERAGE TIME OF OCCUPANCY</b>	<b>73</b>
<b>ATTACHMENT G - HOPPING CHANNEL SEPARATION MEASUREMENT</b>	<b>86</b>
<b>ATTACHMENT H - BANDWIDTH</b>	<b>91</b>
<b>ATTACHMENT I - PEAK OUTPUT POWER</b>	<b>96</b>
<b>ATTACHMENT J - ANTENNA CONDUCTED SPURIOUS EMISSION</b>	<b>101</b>

### REPORT ISSUED HISTORY

Issued No.	Description	Issued Date
BTL-FCCP-1-1607C092	Original Issue.	Jul. 29, 2016

## 1. CERTIFICATION

Equipment : Wireless Headphone  
Brand Name : JBL  
Model Name : T450BT  
Applicant : Harman International Industries, Incorporated  
Manufacturer: Harman International Industries, Incorporated  
Address : 8500 Balboa Blvd, Northridge, CA 91329, UNITED STATES  
Factory : TCL Technoly Electronics(Huizhou) Co.,Ltd  
Address : Section 37, Zhongkai High-tech Development Zone, Huizhou City, Guang  
Dong Province, China, 516006.  
Date of Test : Jul. 15, 2016 ~ Jul. 28, 2016  
Test Sample : Engineering Sample  
Standard(s) : FCC Part15, Subpart C (15.247)/ ANSI C63.10-2013

The above equipment has been tested and found compliance with the requirement of the relative standards by BTL Inc.

The test data, data evaluation, and equipment configuration contained in our test report (Ref No. BTL-FCCP-1-1607C092) were obtained utilizing the test procedures, test instruments, test sites that has been accredited by the Authority of TAF according to the ISO-17025 quality assessment standard and technical standard(s).

## 2. SUMMARY OF TEST RESULTS

Test procedures according to the technical standard(s):

Applied Standard(s): 47 CFR Part 15, Subpart C;			
Standard(s) Section	Test Item	Judgment	Remark
15.207	Conducted Emission	PASS	
15.247(d)	Antenna conducted Spurious Emission	PASS	
15.247 (a)(1)	Hopping Channel Separation	PASS	
15.247(a)(1)	Bandwidth	PASS	
15.247 (b)(1)	Peak Output Power	PASS	
15.247(d) 15.209	Radiated Spurious Emission	PASS	
15.247 (a)(1)(iii)	Number of Hopping Frequency	PASS	
15.247 (a)(1)(iii)	Dwell Time	PASS	
15.205	Restricted Bands	PASS	
15.203	Antenna Requirement	PASS	

Note:

(1) "N/A" denotes test is not applicable in this test report

## 2.1 TEST FACILITY

The test facilities used to collect the test data in this report is at the location of No.3, Jinshagang 1st Road, Shixia, Dalang Town, Dongguan, Guangdong, China.  
BTL's test firm number for FCC: 319330

## 2.2 MEASUREMENT UNCERTAINTY

Where relevant, the following measurement uncertainty levels have been estimated for tests performed on the EUT as specified in CISPR 16-4-2.

The measurement instrumentation uncertainty considerations contained in CISPR 16-4-2.

The reported uncertainty of measurement  $y \pm U$ , where expanded uncertainty  $U$  is based on a standard uncertainty multiplied by a coverage factor of  $k=2$ , providing a level of confidence of approximately **95 %**.

### A. Conducted Measurement :

Test Site	Method	Measurement Frequency Range	U, (dB)
DG-C02	CISPR	150 KHz ~ 30MHz	2.32

### B. Radiated Measurement :

Test Site	Method	Measurement Frequency Range	Ant. H / V	U, (dB)
DG-CB03	CISPR	9KHz~30MHz	V	3.79
		9KHz~30MHz	H	3.57
		30MHz ~ 200MHz	V	3.82
		30MHz ~ 200MHz	H	3.78
		200MHz ~ 1,000MHz	V	4.10
		200MHz ~ 1,000MHz	H	4.06
		1GHz~18GHz	V	3.12
		1GHz~18GHz	H	3.68
		18GHz~40GHz	V	4.15
		18GHz~40GHz	H	4.14

Note: Unless specifically mentioned, the uncertainty of measurement has not been taken into account to declare the compliance or non-compliance to the specification.

### 3. GENERAL INFORMATION

#### 3.1 GENERAL DESCRIPTION OF EUT

Equipment	Wireless Headphone	
Brand Name	JBL	
Model Name	T450BT	
Model Difference	N/A	
Output Power (Max.)	Operation Frequency	2402~2480 MHz
	Modulation Technology	GFSK(1Mbps) $\pi/4$ -DQPSK(2Mbps)
	Bit Rate of Transmitter	8-DPSK(3Mbps)
	Output Power Max.	3.81 dBm(1Mbps) 3.89 dBm(3Mbps)
Power Source	#1 DC voltage supplied from USB port. #2 Supplied from battery.	
Power Rating	#1 EUT I/P: DC 5V #2 I/P: DC 3.7V	

Note:

1. For a more detailed features description, please refer to the manufacturer's specifications or the user's manual.

2. Channel List:

Channel	Frequency (MHz)	Channel	Frequency (MHz)	Channel	Frequency (MHz)
00	2402	27	2429	54	2456
01	2403	28	2430	55	2457
02	2404	29	2431	56	2458
03	2405	30	2432	57	2459
04	2406	31	2433	58	2460
05	2407	32	2434	59	2461
06	2408	33	2435	60	2462
07	2409	34	2436	61	2463
08	2410	35	2437	62	2464
09	2411	36	2438	63	2465
10	2412	37	2439	64	2466
11	2413	38	2440	65	2467
12	2414	39	2441	66	2468
13	2415	40	2442	67	2469
14	2416	41	2443	68	2470
15	2417	42	2444	69	2471
16	2418	43	2445	70	2472
17	2419	44	2446	71	2473
18	2420	45	2447	72	2474
19	2421	46	2448	73	2475
20	2422	47	2449	74	2476
21	2423	48	2450	75	2477
22	2424	49	2451	76	2478
23	2425	50	2452	77	2479
24	2426	51	2453	78	2480
25	2427	52	2454		
26	2428	53	2455		

3. Table for Filed Antenna

Ant.	Brand	Model Name	Antenna Type	Connector	Gain (dBi)
1	N/A	N/A	PIFA	N/A	1.0

### 3.2 DESCRIPTION OF TEST MODES

To investigate the maximum EMI emission characteristics generated from EUT, the test system was pre-scanning tested based on the consideration of following EUT operation mode or test configuration mode which possibly have effect on EMI emission level. Each of these EUT operation mode(s) or test configuration mode(s) mentioned above was evaluated respectively.

Pretest Mode	Description
Mode 1	TX Mode <b>Note (1)</b>

The EUT system operated these modes were found to be the worst case during the pre-scanning test as following:

For Conducted Emission	
Final Test Mode	Description
Mode 1	TX Mode

For Radiated Emission	
Final Test Mode	Description
Mode 1	TX Mode <b>Note (1)</b>

**Note:**

- (1) The measurements are performed at the high, middle, low available channels.
- (2) The measurements for Hopping Channel Separation, Bandwidth and Peak Output Power were tested during 1Mbps, 2Mbps and 3Mbps, the worst case are 1Mbps and 3Mbps, only worst case was documented.
- (3) USB port and battery are evaluated, USB port is the worst case of conduction test, and battery is the worst case of other projects.

### 3.3 TABLE OF PARAMETERS OF TEST SOFTWARE SETTING

During testing, channel & power controlling software provided by the customer was used to control the operating channel as well as the output power level. The RF output power selection is for the setting of RF output power expected by the customer and is going to be fixed on the firmware of the final end product power parameters of FHSS

Test Software Version	Bluetest 3		
	2402 MHz	2441 MHz	2480 MHz
Frequency	2402 MHz	2441 MHz	2480 MHz
Parameters(1Mbps)	38	8	5
Parameters(3Mbps)	48	28	26

**3.4 BLOCK DIAGRAM SHOWING THE CONFIGURATION OF SYSTEM TESTED**

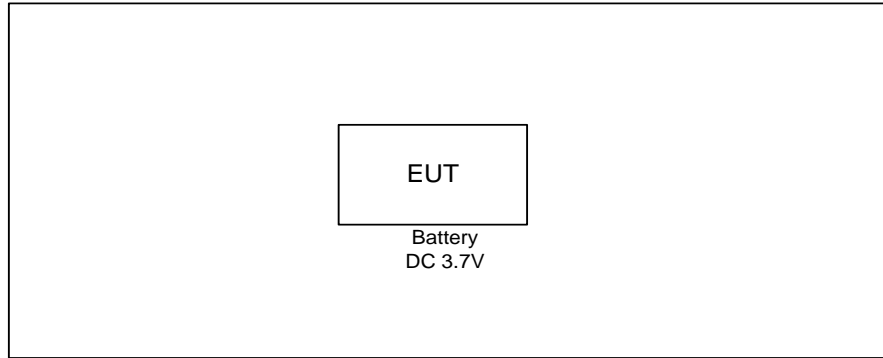

-----  
 Control Room

**3.5 DESCRIPTION OF SUPPORT UNITS**

The EUT has been tested as an independent unit together with other necessary accessories or support units. The following support units or accessories were used to form a representative test configuration during the tests.

Item	Equipment	Mfr/Brand	Model/Type No.	FCC ID	Series No.
-	-	-	-	-	-

Item	Shielded Type	Ferrite Core	Length	Note
-	-	-	-	-

## 4. EMC EMISSION TEST

### 4.1 CONDUCTED EMISSION MEASUREMENT

#### 4.1.1 POWER LINE CONDUCTED EMISSION LIMITS (Frequency Range 150KHz-30MHz)

Frequency of Emission (MHz)	Conducted Limit (dB $\mu$ V)	
	Quasi-peak	Average $\square$
0.15 -0.50	66 to 56*	56 to 46*
0.50 -5.0	56	46
5.0 -30.0	60	50

Note:

- (1) The limit of " \* " decreases with the logarithm of the frequency
- (2) The test result calculated as following:  
 Measurement Value = Reading Level + Correct Factor  
 Correct Factor = Insertion Loss + Cable Loss + Attenuator Factor(if use)  
 Margin Level = Measurement Value - Limit Value

The following table is the setting of the receiver

Receiver Parameters	Setting
Attenuation	10 dB
Start Frequency	0.15 MHz
Stop Frequency	30 MHz
IF Bandwidth	9 KHz

#### 4.1.2 TEST PROCEDURE

- a. The EUT was placed 0.8 meters from the horizontal ground plane with EUT being connected to the power mains through a line impedance stabilization network (LISN). All other support equipment powered from additional LISN(s). The LISN provide 50 Ohm/ 50uH of coupling impedance for the measuring instrument.
- b. Interconnecting cables that hang closer than 40 cm to the ground plane shall be folded back and forth in the center forming a bundle 30 to 40 cm long.
- c. I/O cables that are not connected to a peripheral shall be bundled in the center. The end of the cable may be terminated, if required, using the correct terminating impedance. The overall length shall not exceed 1 m.
- d. LISN at least 80 cm from nearest part of EUT chassis.
- e. For the actual test configuration, please refer to the related Item –EUT Test Photos.

#### 4.1.3 DEVIATION FROM TEST STANDARD

No deviation

**4.1.4 TEST SETUP**

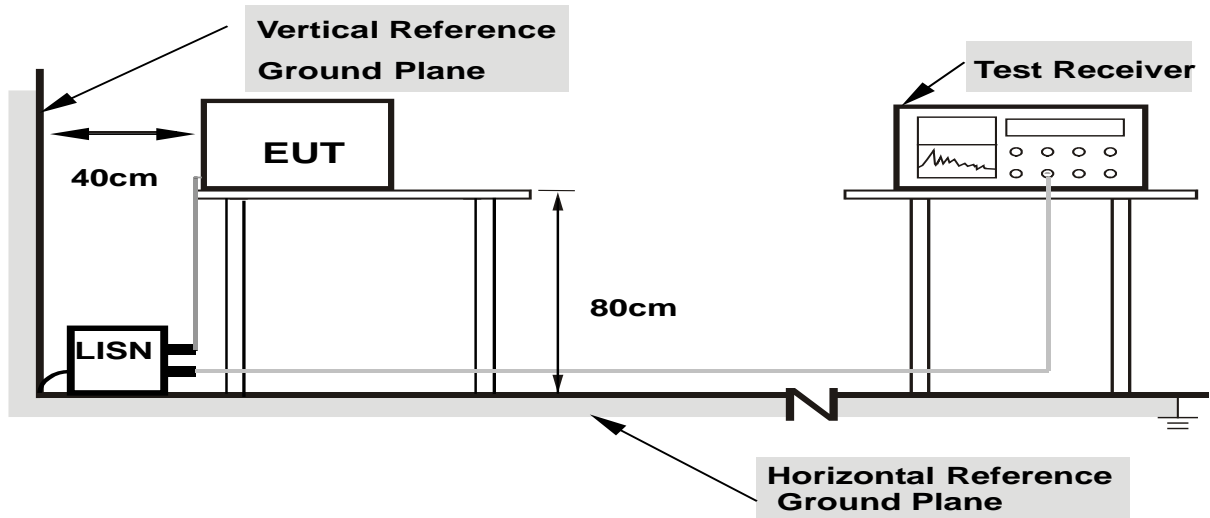

- Note:**
1. Support units were connected to second LISN.
  2. Both of LISNs (AMN) are 80 cm from EUT and at least 80 from other units and other metal planes

**4.1.5 EUT OPERATING CONDITIONS**

The EUT was configured for testing in a typical function (as a customer would normally use it), EUT was programmed to be in continuously transmitting/receiving data or hopping on mode.

**4.1.6 EUT TEST CONDITIONS**

Temperature: 25°C  
 Relative Humidity: 55%  
 Test Voltage: AC 120V/60Hz

**4.1.7 TEST RESULTS**

Please refer to the Attachment A.

Remark:

- (1) All readings are QP Mode value unless otherwise stated AVG in column of 『Note』. If the QP Mode Measured value compliance with the QP Limits and lower than AVG Limits, the EUT shall be deemed to meet both QP & AVG Limits and then only QP Mode was measured, but AVG Mode didn't perform in this case, a "\*" marked in AVG Mode column of Interference Voltage Measured.
- (2) Measuring frequency range from 150KHz to 30MHz.

## 4.2 RADIATED EMISSION MEASUREMENT

### 4.2.1 RADIATED EMISSION LIMITS (Frequency Range 9KHz -1000MHz)

In case the emission fall within the restricted band specified on 15.205(a), then the 15.209(a) limit in the table below has to be followed.

Frequency (MHz)	Field Strength (microvolts/meter)	Measurement Distance (meters)
0.009~0.490	2400/F(KHz)	300
0.490~1.705	24000/F(KHz)	30
1.705~30.0	30	30
30~88	100	3
88~216	150	3
216~960	200	3
960~1000	500	3

### LIMITS OF RADIATED EMISSION MEASUREMENT (Above 1000MHz)

Frequency (MHz)	dB(uV/m) (at 3 meters)	
	Peak	Average
Above 1000	74	54

Notes:

- (1) The limit for radiated test was performed according to FCC PART 15C.
- (2) The tighter limit applies at the band edges.
- (3) Emission level (dBuV/m) = 20log Emission level (uV/m).
- (4) The test result calculated as following:  
 Measurement Value = Reading Level + Correct Factor  
 Correct Factor = Antenna Factor + Cable Loss - Amplifier Gain(if use)  
 Margin Level = Measurement Value - Limit Value

Spectrum Parameter	Setting
Attenuation	Auto
Start Frequency	1000 MHz
Stop Frequency	10th carrier harmonic
RBW / VBW (emission in restricted band)	1 MHz / 1 MHz for Peak, 1 MHz / 10Hz for Average

Spectrum Receiver Parameter	Setting
Attenuation	Auto
Start ~ Stop Frequency	9KHz ~90KHz for PK/AVG detector
Start ~ Stop Frequency	90KHz ~110KHz for QP detector
Start ~ Stop Frequency	110KHz ~490KHz for PK/AVG detector
Start ~ Stop Frequency	490KHz ~30MHz for QP detector
Start ~ Stop Frequency	30MHz~1000MHz for QP detector

**4.2.2 TEST PROCEDURE**

- a. The measuring distance of 3 m shall be used for measurements. The EUT was placed on the top of a rotating table 0.8 meter above the ground at a 3 meter semi-anechoic chamber. The table was rotated 360 degrees to determine the position of the highest radiation.(below 1GHz)
- b. The measuring distance of 3 m shall be used for measurements. The EUT was placed on the top of a rotating table 1.5 meter above the ground at a 3 meter semi-anechoic chamber. The table was rotated 360 degrees to determine the position of the highest radiation.(above 1GHz)
- c. The height of the equipment or of the substitution antenna shall be 0.8 m or 1.5m, the height of the test antenna shall vary between 1 m to 4 m. Both horizontal and vertical polarizations of the antenna are set to make the measurement.
- d. For each suspected emission, the EUT was arranged to its worst case and then the antenna was tuned to heights find the maximum reading (used Bore sight function).
- e. The receiver system was set to peak and average detect function and specified bandwidth with maximum hold mode when the test frequency is above 1GHz.
- f. The initial step in collecting radiated emission data is a receiver peak detector mode pre-scanning the measurement frequency range. Significant peaks are then marked and then Quasi Peak detector mode re-measured.
- g. All readings are Peak unless otherwise stated QP in column of Note. Peak denotes that the Peak reading compliance with the QP Limits and then QP Mode measurement didn't perform. (below 1GHz)
- h. All readings are Peak Mode value unless otherwise stated AVG in column of Note. If the Peak Mode Measured value compliance with the Peak Limits and lower than AVG Limits, the EUT shall be deemed to meet both Peak & AVG Limits and then only Peak Mode was measured, but AVG Mode didn't perform. (above 1GHz)
- i. For the actual test configuration, please refer to the related Item –EUT Test Photos.

**4.2.3 DEVIATION FROM TEST STANDARD**

No deviation

**4.2.4 TEST SETUP**

(A) Radiated Emission Test Set-Up Frequency Below 1 GHz

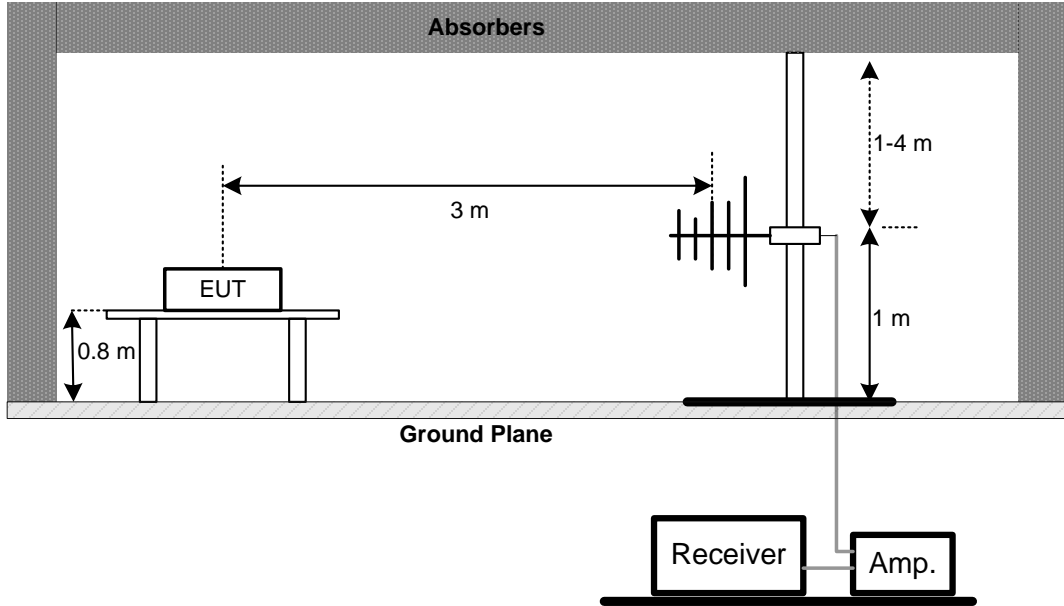

(B) Radiated Emission Test Set-Up Frequency Above 1 GHz

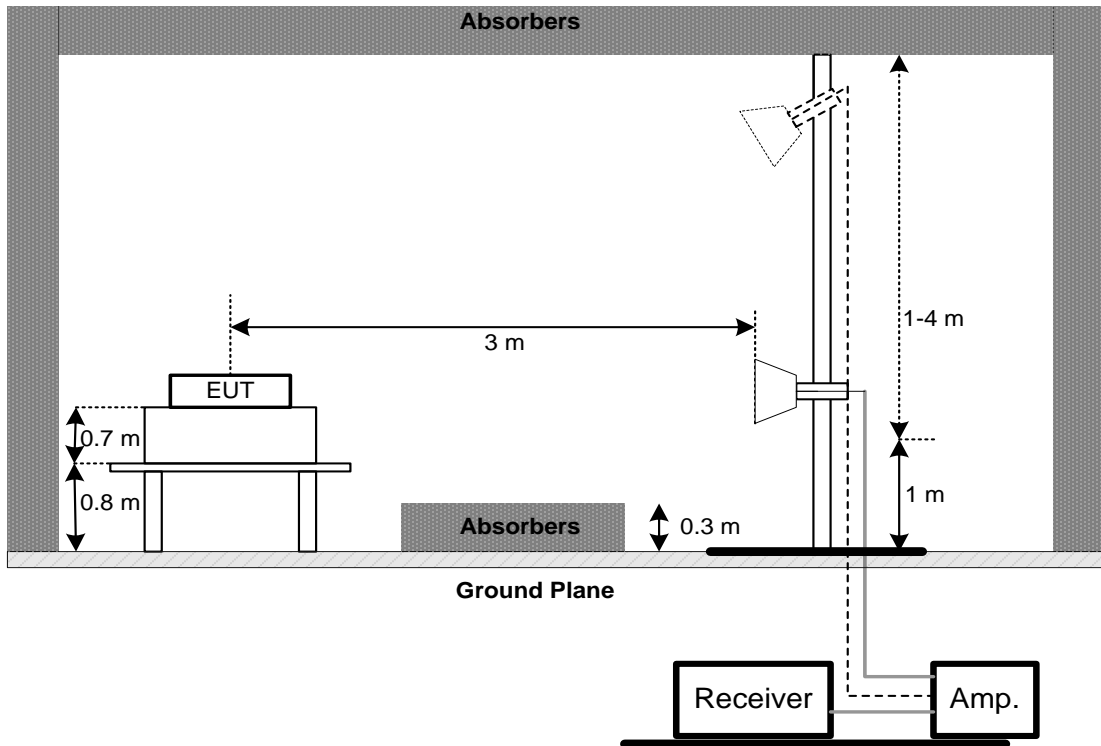

(C) For Radiated Emissions Below 30MHz

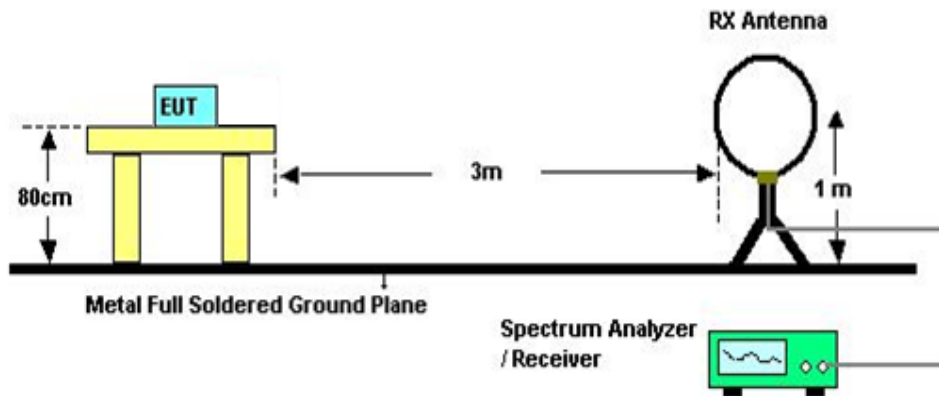

**4.2.5 EUT OPERATING CONDITIONS**

The EUT tested system was configured as the statements of 4.1.5 unless otherwise a special operating condition is specified in the follows during the testing

**4.2.6 EUT TEST CONDITIONS**

Temperature: 25°C  
 Relative Humidity: 55%  
 Test Voltage: DC 3.7V

**4.2.7 TEST RESULTS (9KHZ TO 30MHZ)**

Please refer to the Attachment B

Remark:

- (1) The amplitude of spurious emissions which are attenuated by more than 20 dB below the permissible value has no need to be reported.
- (2) Distance extrapolation factor =  $40 \log(\text{specific distance} / \text{test distance})$  (dB).
- (3) Limit line = specific limits (dBuV) + distance extrapolation factor.

#### 4.2.8 TEST RESULTS (30MHZ TO 1000 MHZ)

Please refer to the Attachment C.

Remark:

- (1) All readings are Peak unless otherwise stated QP in column of 『Note』. Peak denotes that the Peak reading compliance with the QP Limits and then QP Mode measurement didn't perform.
- (2) Measuring frequency range from 30MHz to 1000MHz.
- (3) If the peak scan value lower limit more than 20dB, then this signal data does not show in table.

#### 4.2.9 TEST RESULTS (ABOVE 1000 MHZ)

Please refer to the Attachment D.

Remark:

- (1) Radiated emissions measured in frequency range above 1000MHz were made with an instrument using Peak detector mode and AV detector mode of the emission
- (2) A preamp and high pass filter were used for this test in order to provide sufficient measurement sensitivity.
- (3) EUT Orthogonal Axis:  
"X" - denotes Laid on Table; "Y" - denotes Vertical Stand; "Z" - denotes Side Stand
- (4) During the measurements above 1 GHz it is taken care of that the EUT is always within the 3 dB cone of radiation BW of the used antenna
- (5) No limit: This is fundamental signal, the judgment is not applicable.  
For fundamental signal judgment was referred to Peak output test.

**5. NUMBER OF HOPPING CHANNEL**

**5.1 APPLIED PROCEDURES**

FCC Part15 (15.247) , Subpart C			
Section	Test Item	Frequency Range (MHz)	Result
15.247(a)(1)(iii)	Number of Hopping Channel	2400-2483.5	PASS

Spectrum Parameters	Setting
Attenuation	Auto
Span Frequency	> Operating Frequency Range
RBW	100 KHz
VBW	100 KHz
Detector	Peak
Trace	Max Hold
Sweep Time	Auto

**5.1.1 TEST PROCEDURE**

- a. The EUT was directly connected to the spectrum analyzer and antenna output port as show in the block diagram below,
- b. Spectrum Setting: RBW=100KHz, VBW=100KHz, Sweep time = Auto.

**5.1.2 DEVIATION FROM STANDARD**

No deviation.

**5.1.3 TEST SETUP**



**5.1.4 EUT OPERATION CONDITIONS**

The EUT tested system was configured as the statements of 4.1.5 unless otherwise a special operating condition is specified in the follows during the testing.

**5.1.5 EUT TEST CONDITIONS**

Temperature: 25°C  
 Relative Humidity: 55%  
 Test Voltage: DC 3.7V

**5.1.6 TEST RESULTS**

Please refer to the Attachment E

**6. AVERAGE TIME OF OCCUPANCY**

**6.1 APPLIED PROCEDURES / LIMIT**

FCC Part15 (15.247) , Subpart C				
Section	Test Item	Limit	Frequency Range (MHz)	Result
15.247(a)(1)(iii)	Average Time of Occupancy	0.4sec	2400-2483.5	PASS

**6.1.1 TEST PROCEDURE**

- a. The transmitter output (antenna port) was connected to the spectrum analyzer
- b. Set RBW of spectrum analyzer to 1MHz and VBW to 1MHz.
- c. Use a video trigger with the trigger level set to enable triggering only on full pulses.
- d. Sweep Time is more than once pulse time.
- e. Set the center frequency on any frequency would be measure and set the frequency span to zero span.
- f. Measure the maximum time duration of one single pulse.
- g. Set the EUT for DH5, DH3 and DH1 packet transmitting.
- h. Measure the maximum time duration of one single pulse.
- i. DH5 Packet permit maximum  $1600 / 79 / 6 = 3.37$  hops per second in each channel (5 time slots TX, 1 time slot RX). So, the dwell time is the time duration of the pulse times  $3.37 \times 31.6 = 106.6$  within 31.6 seconds.
- j. DH3 Packet permit maximum  $1600 / 79 / 4 = 5.06$  hops per second in each channel (3 time slots TX, 1 time slot RX). So, the dwell time is the time duration of the pulse times  $5.06 \times 31.6 = 160$  within 31.6 seconds.
- k. DH1 Packet permit maximum  $1600 / 79 / 2 = 10.12$  hops per second in each channel (1 time slot TX, 1 time slot RX). So, the dwell time is the time duration of the pulse times  $10.12 \times 31.6 = 320$  within 31.6 seconds.

**6.1.2 DEVIATION FROM STANDARD**

No deviation.

**6.1.3 TEST SETUP**



#### **6.1.4 EUT OPERATION CONDITIONS**

The EUT tested system was configured as the statements of 4.1.5 unless otherwise a special operating condition is specified in the follows during the testing.

#### **6.1.5 EUT TEST CONDITIONS**

Temperature: 25°C

Relative Humidity: 55%

Test Voltage: DC 3.7V

#### **6.1.6 TEST RESULTS**

Please refer to the Attachment F

## 7. HOPPING CHANNEL SEPARATION MEASUREMENT

### 7.1 APPLIED PROCEDURES / LIMIT

Frequency hopping systems operating in the 2400-2483.5 MHz band may have hopping channel carrier frequencies that are separated by 25 KHz or two-thirds of the 20 dB bandwidth of the hopping channel, whichever is greater.

Spectrum Parameter	Setting
Attenuation	Auto
Span Frequency	> Measurement Bandwidth or Channel Separation
RBW	30 KHz
VBW	100 KHz
Detector	Peak
Trace	Max Hold
Sweep Time	Auto

#### 7.1.1 TEST PROCEDURE

- a. The EUT must have its hopping function enabled
- b. Span = wide enough to capture the peaks of two adjacent channels
  - Resolution (or IF) Bandwidth (RBW)  $\geq$  1% of the span
  - Video (or Average) Bandwidth (VBW)  $\geq$  RBW
  - Sweep = Auto
  - Detector function = Peak
  - Trace = Max Hold

#### 7.1.2 DEVIATION FROM STANDARD

No deviation.

#### 7.1.3 TEST SETUP

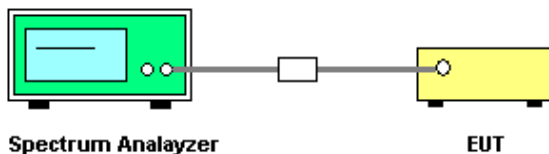

#### 7.1.4 EUT TEST CONDITIONS

Temperature: 25°C  
 Relative Humidity: 55%  
 Test Voltage: DC 3.7V

#### 7.1.5 TEST RESULTS

Please refer to the Attachment G

## 8. BANDWIDTH TEST

### 8.1 APPLIED PROCEDURES

FCC Part15 (15.247) , Subpart C		
Section	Test Item	Frequency Range (MHz)
15.247(a)(2)	Bandwidth	2400-2483.5

Spectrum Parameter	Setting
Attenuation	Auto
Span Frequency	> Measurement Bandwidth or Channel Separation
RBW	30 KHz (20dB Bandwidth) / 30 KHz (Channel Separation)
VBW	100 KHz (20dB Bandwidth) / 100 KHz (Channel Separation)
Detector	Peak
Trace	Max Hold
Sweep Time	Auto

#### 8.1.1 TEST PROCEDURE

- a. The EUT was directly connected to the spectrum analyzer and antenna output port as show in the block diagram below,
- b. Spectrum Setting: RBW= 30KHz, VBW=100KHz, Sweep Time = Auto.

#### 8.1.2 DEVIATION FROM STANDARD

No deviation.

#### 8.1.3 TEST SETUP

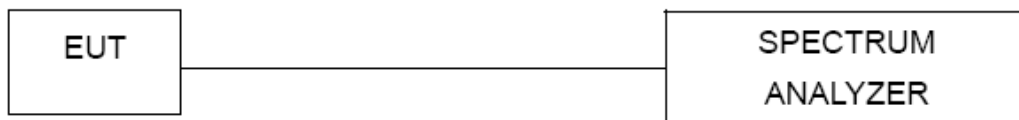

#### 8.1.4 EUT OPERATION CONDITIONS

The EUT tested system was configured as the statements of 4.1.5 unless otherwise a special operating condition is specified in the follows during the testing.

#### 8.1.5 EUT TEST CONDITIONS

Temperature: 25°C  
 Relative Humidity: 55%  
 Test Voltage: DC 3.7V

#### 8.1.6 TEST RESULTS

Please refer to the Attachment H

## 9. PEAK OUTPUT POWER TEST

### 9.1 APPLIED PROCEDURES / LIMIT

FCC Part15 (15.247) , Subpart C				
Section	Test Item	Limit	Frequency Range (MHz)	Result
15.247(b)(1)	Peak Output Power	1 Watt or 30dBm ( hopping channel >75) 0.125Watt or 21dBm (hopping channel <75)	2400-2483.5	PASS

#### 9.1.1 TEST PROCEDURE

- a. The EUT was directly connected to the spectrum analyzer and antenna output port as show in the block diagram below,
- b. Spectrum Setting: RBW= 1MHz/3MHz, VBW= 1MHz/3MHz, Sweep time = Auto.

#### 9.1.2 DEVIATION FROM STANDARD

No deviation.

#### 9.1.3 TEST SETUP

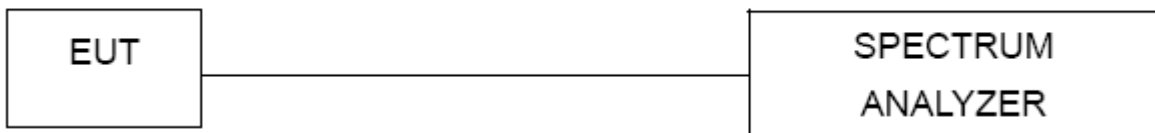

#### 9.1.4 EUT OPERATION CONDITIONS

The EUT tested system was configured as the statements of 4.1.5 unless otherwise a special operating condition is specified in the follows during the testing.

#### 9.1.5 EUT TEST CONDITIONS

Temperature: 25°C  
Relative Humidity: 55%  
Test Voltage: DC 3.7V

#### 9.1.6 TEST RESULTS

Please refer to the Attachment I

## 10. ANTENNA CONDUCTED SPURIOUS EMISSION

### 10.1 APPLIED PROCEDURES / LIMIT

In any 100 kHz bandwidth outside the frequency band in which the spread spectrum or digitally modulated device is operating, the RF power that is produced shall be at least 20 dB below that in the 100 kHz bandwidth within the band that contains the highest level of the desired power, based on either an RF conducted or a radiated measurement, provided that the transmitter demonstrates compliance with the peak conducted power limits.

#### 10.1.1 TEST PROCEDURE

- a. The EUT was directly connected to the spectrum analyzer and antenna output port as show in the block diagram below,
- b. Spectrum Setting: RBW= 100KHz, VBW=100KHz, Sweep time = Auto.
- c. Offset=antenna gain+cable loss

#### 10.1.2 DEVIATION FROM STANDARD

No deviation.

#### 10.1.3 TEST SETUP



#### 10.1.4 EUT OPERATION CONDITIONS

The EUT tested system was configured as the statements of 4.1.5 unless otherwise a special operating condition is specified in the follows during the testing.

#### 10.1.5 EUT TEST CONDITIONS

Temperature: 25°C  
 Relative Humidity: 55%  
 Test Voltage: DC 3.7V

#### 10.1.6 TEST RESULTS

Please refer to the Attachment J

## 11. MEASUREMENT INSTRUMENTS LIST

Conducted Emission Measurement					
Item	Kind of Equipment	Manufacturer	Type No.	Serial No.	Calibrated until
1	LISN	EMCO	3816/2	0052765	Mar. 27, 2017
2	LISN	R&S	ENV216	101447	Mar. 27, 2017
3	Test Cable	emci	RG223(9KHz-30 MHz)	C_17	Mar. 10, 2017
4	EMI Test Receiver	R&S	ESCI	100382	Mar. 27, 2017
5	50Ω Terminator	SHX	TF2-3G-A	08122901	Mar. 27, 2017
6	Measurement Software	Farad	EZ-EMC Ver.NB-03A1-01	N/A	N/A

Radiated Emission Measurement					
Item	Kind of Equipment	Manufacturer	Type No.	Serial No.	Calibrated until
1	Active Loop Antenna	R&S	HFH2-Z2	830749/020	Sep. 07, 2016
2	Antenna	Schwarzbeck	VULB9160	9160-3232	Mar. 27, 2017
3	Amplifier	HP	8447D	2944A09673	Nov. 09, 2016
4	Receiver	AGILENT	N9038A	MY52130039	Oct. 11, 2016
5	Test Cable	emci	LMR-400(30MHz-1GHz)	C-01	Jun. 27, 2017
6	Control	CT	SC100	N/A	N/A
7	Position Control	MF	MF-7802	MF780208416	N/A
8	Measurement Software	Farad	EZ-EMC Ver.NB-03A1-01	N/A	N/A
9	Antenna	ETS	3115	00075789	Mar. 27, 2017
10	Amplifier	Agilent	8449B	3008A02274	Nov. 01, 2016
11	Test Cable	emci	EMC104-SM-S M-10000(1GHz – 26.5GHz)	C-68	Jun. 27, 2017
12	Broad-Band Horn Antenna	Schwarzbeck	BBHA 9170	9170319	Apr. 23, 2017
13	Microwave Pre-amplifier With Adaptor	EMC INSTRUMENT	EMC2654045	980039 & HA01	Mar. 27, 2017

Number of Hopping Channel					
Item	Kind of Equipment	Manufacturer	Type No.	Serial No.	Calibrated until
1	EXA Spectrum Analyzer	Agilent	N9010A	MY50520044	Mar. 27, 2017

Average Time of Occupancy					
Item	Kind of Equipment	Manufacturer	Type No.	Serial No.	Calibrated until
1	EXA Spectrum Analyzer	Agilent	N9010A	MY50520044	Mar. 27, 2017

Hopping Channel Separation Measurement					
Item	Kind of Equipment	Manufacturer	Type No.	Serial No.	Calibrated until
1	EXA Spectrum Analyzer	Agilent	N9010A	MY50520044	Mar. 27, 2017

Bandwidth					
Item	Kind of Equipment	Manufacturer	Type No.	Serial No.	Calibrated until
1	EXA Spectrum Analyzer	Agilent	N9010A	MY50520044	Mar. 27, 2017

Peak Output Power					
Item	Kind of Equipment	Manufacturer	Type No.	Serial No.	Calibrated until
1	EXA Spectrum Analyzer	Agilent	N9010A	MY50520044	Mar. 27, 2017

Antenna Conducted Spurious Emission					
Item	Kind of Equipment	Manufacturer	Type No.	Serial No.	Calibrated until
1	EXA Spectrum Analyzer	Agilent	N9010A	MY50520044	Mar. 27, 2017

Remark: "N/A" denotes no model name, serial no. or calibration specified.  
 All calibration period of equipment list is one year.

## ATTACHMENT A - CONDUCTED EMISSION

Test Mode: TX Mode

**Line**

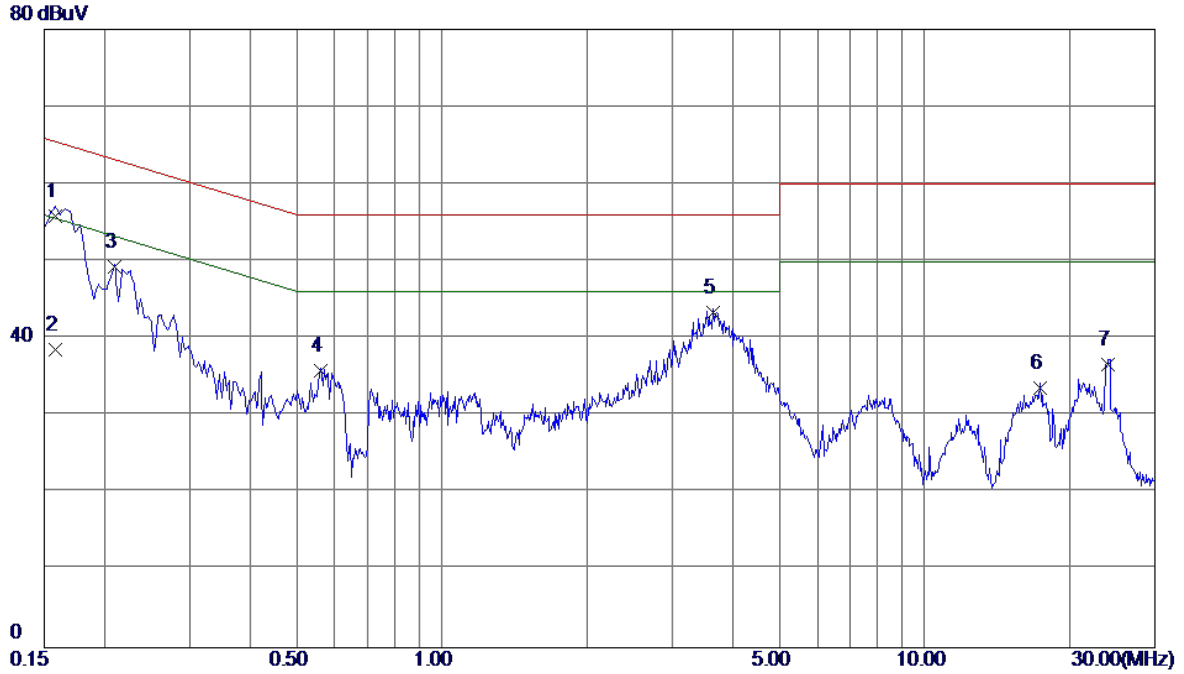

No.	Freq. MHz	Reading Level dBuV	Correct Factor dB	Measure ment dBuV	Limit dBuV	Margin dB	Detector	Comment
1 *	0.1580	46.37	9.52	55.89	65.57	-9.68	QP	
2	0.1580	29.10	9.52	38.62	55.57	-16.95	AVG	
3	0.2100	39.72	9.53	49.25	63.21	-13.96	QP	
4	0.5620	26.27	9.64	35.91	56.00	-20.09	QP	
5	3.6540	33.18	10.16	43.34	56.00	-12.66	QP	
6	17.3380	23.19	10.38	33.57	60.00	-26.43	QP	
7	24.0459	26.32	10.39	36.71	60.00	-23.29	QP	

Test Mode: TX Mode

**Neutral**

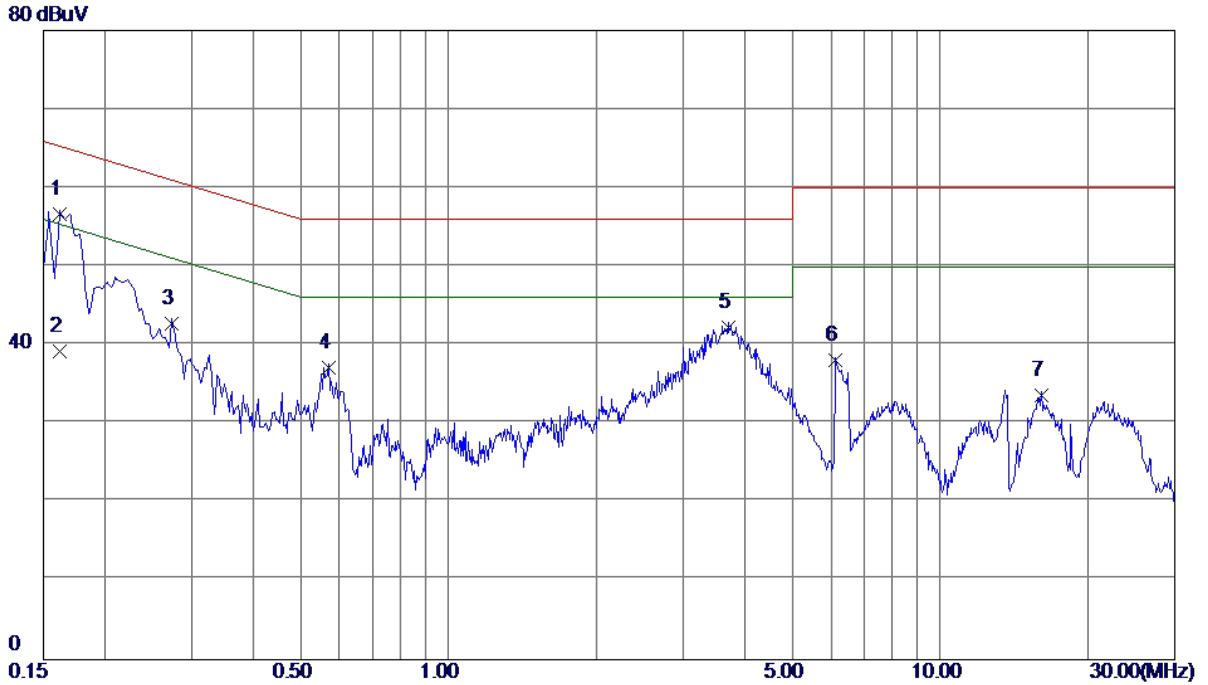

No.	Freq. MHz	Reading Level dBuV	Correct Factor dB	Measure ment dBuV	Limit dBuV	Margin dB	Detector	Comment
1 *	0.1620	47.15	9.46	56.61	65.36	-8.75	QP	
2	0.1620	29.70	9.46	39.16	55.36	-16.20	AVG	
3	0.2740	33.13	9.53	42.66	61.00	-18.34	QP	
4	0.5700	27.65	9.44	37.09	56.00	-18.91	QP	
5	3.7180	32.35	9.86	42.21	56.00	-13.79	QP	
6	6.1380	28.11	9.97	38.08	60.00	-21.92	QP	
7	16.0700	23.21	10.39	33.60	60.00	-26.40	QP	

## ATTACHMENT B - RADIATED EMISSION (9KHZ-30MHZ)

Test Mode:	TX Mode
------------	---------

Frequency (MHz)	Ant 0°/90°	Read level dBuV/m	Factor (dB)	Measured(FS) (dBuV/m)	Limit (dBuV/m)	Margin (dB)	Note
0.0097	0°	13.61	24.9523	38.5623	127.8688	-89.3065	AVG
0.0097	0°	14.88	24.9523	39.8323	147.8688	-108.0365	PEAK
0.0215	0°	6.73	24.2050	30.9350	120.9555	-90.0205	AVG
0.0215	0°	8.12	24.2050	32.3250	140.9555	-108.6305	PEAK
0.0368	0°	3.17	23.2360	26.4060	116.2873	-89.8813	AVG
0.0368	0°	5.58	23.2360	28.8160	136.2873	-107.4713	PEAK
0.0583	0°	1.16	22.2340	23.3940	112.2909	-88.8969	AVG
0.0583	0°	2.53	22.2340	24.7640	132.2909	-107.5269	PEAK
0.5098	0°	19.36	19.8314	39.1914	73.4562	-34.2649	QP
1.9525	0°	23.71	19.5048	43.2148	69.5400	-26.3252	QP

Frequency (MHz)	Ant 0°/90°	Read level dBuV/m	Factor (dB)	Measured(FS) (dBuV/m)	Limit (dBuV/m)	Margin (dB)	Note
0.0125	90°	13.16	24.3000	37.4600	125.6660	-88.2060	AVG
0.0125	90°	14.89	24.3000	39.1900	145.6660	-106.4760	PEAK
0.0267	90°	7.28	23.8757	31.1557	119.0740	-87.9183	AVG
0.0267	90°	8.94	23.8757	32.8157	139.0740	-106.2583	PEAK
0.0434	90°	5.23	22.8180	28.0480	114.8544	-86.8064	AVG
0.0434	90°	6.19	22.8180	29.0080	134.8544	-105.8464	PEAK
0.0583	90°	1.54	22.2340	23.7740	112.2909	-88.5169	AVG
0.0583	90°	2.86	22.2340	25.0940	132.2909	-107.1969	PEAK
0.6217	90°	22.17	20.1894	42.3594	71.7326	-29.3732	QP
2.0548	90°	24.56	19.4671	44.0271	69.5400	-25.5129	QP

## ATTACHMENT C - RADIATED EMISSION (30MHZ TO 1000MHZ)

Test Mode: TX 2402MHz \_CH00\_1Mbps

**Vertical**

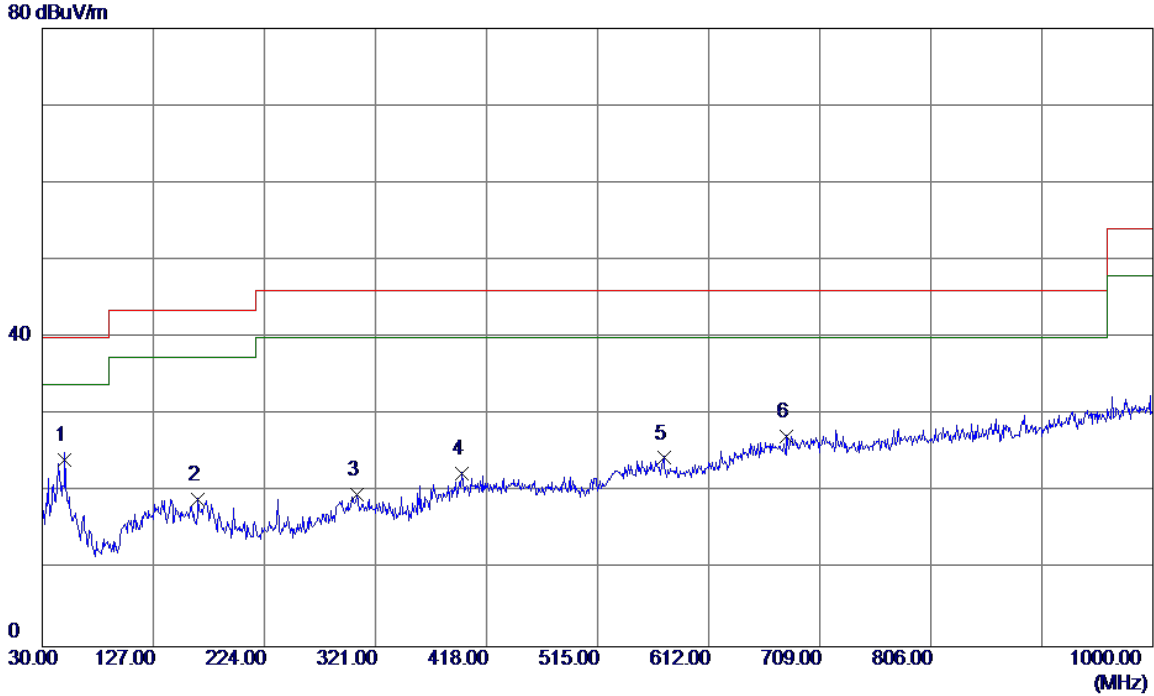

No.	Freq. MHz	Reading Level dBuV/m	Correct Factor dB	Measurement dBuV/m	Limit dBuV/m	Margin dB	Detector	Comment
1 *	49.4000	36.33	-12.16	24.17	40.00	-15.83	QP	
2	166.2850	30.41	-11.39	19.02	43.50	-24.48	QP	
3	304.9950	29.65	-10.02	19.63	46.00	-26.37	QP	
4	396.1750	29.81	-7.47	22.34	46.00	-23.66	QP	
5	572.7150	29.02	-4.62	24.40	46.00	-21.60	QP	
6	680.3850	28.27	-1.06	27.21	46.00	-18.79	QP	

Test Mode: TX 2402MHz \_CH00\_1Mbps

### Horizontal

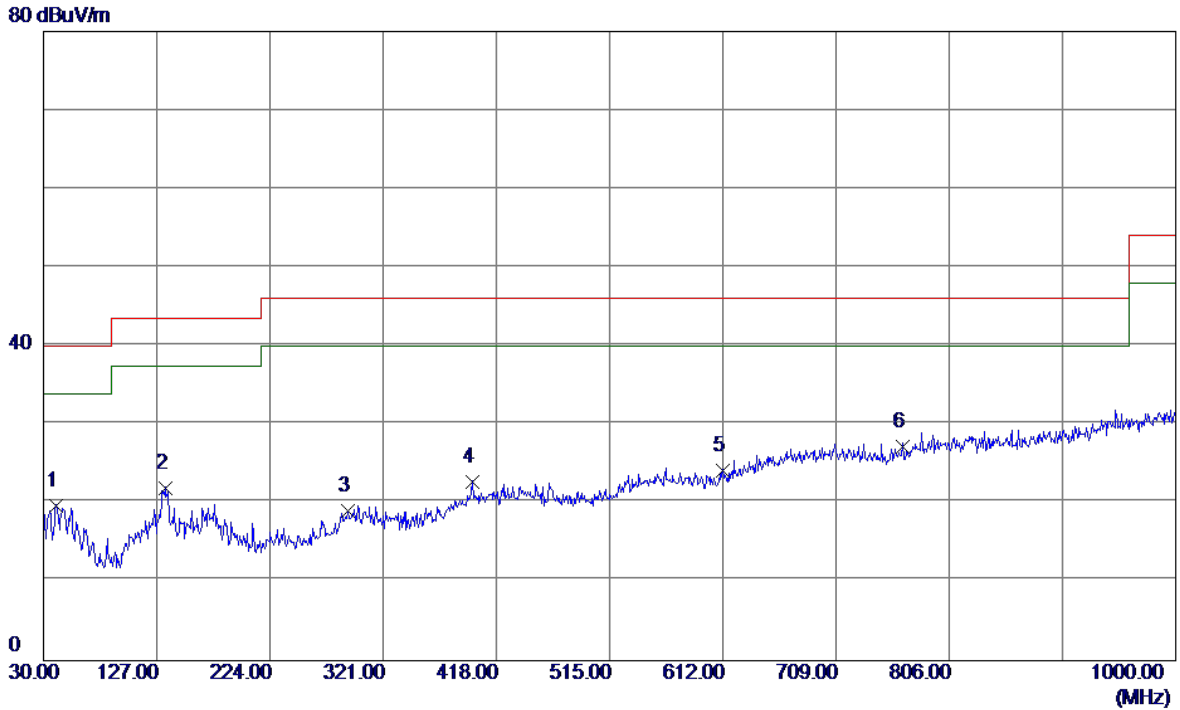

No.	Freq. MHz	Reading Level dBuV/m	Correct Factor dB	Measurement dBuV/m	Limit dBuV/m	Margin dB	Detector	Comment
1	40.6699	32.07	-12.38	19.69	40.00	-20.31	QP	
2	134.2750	33.36	-11.46	21.90	43.50	-21.60	QP	
3	290.9300	29.03	-9.98	19.05	46.00	-26.95	QP	
4	397.1450	30.12	-7.40	22.72	46.00	-23.28	QP	
5	612.4850	28.26	-4.05	24.21	46.00	-21.79	QP	
6 *	766.2300	27.64	-0.39	27.25	46.00	-18.75	QP	

Test Mode: TX 2441MHz \_CH39\_1Mbps

**Vertical**

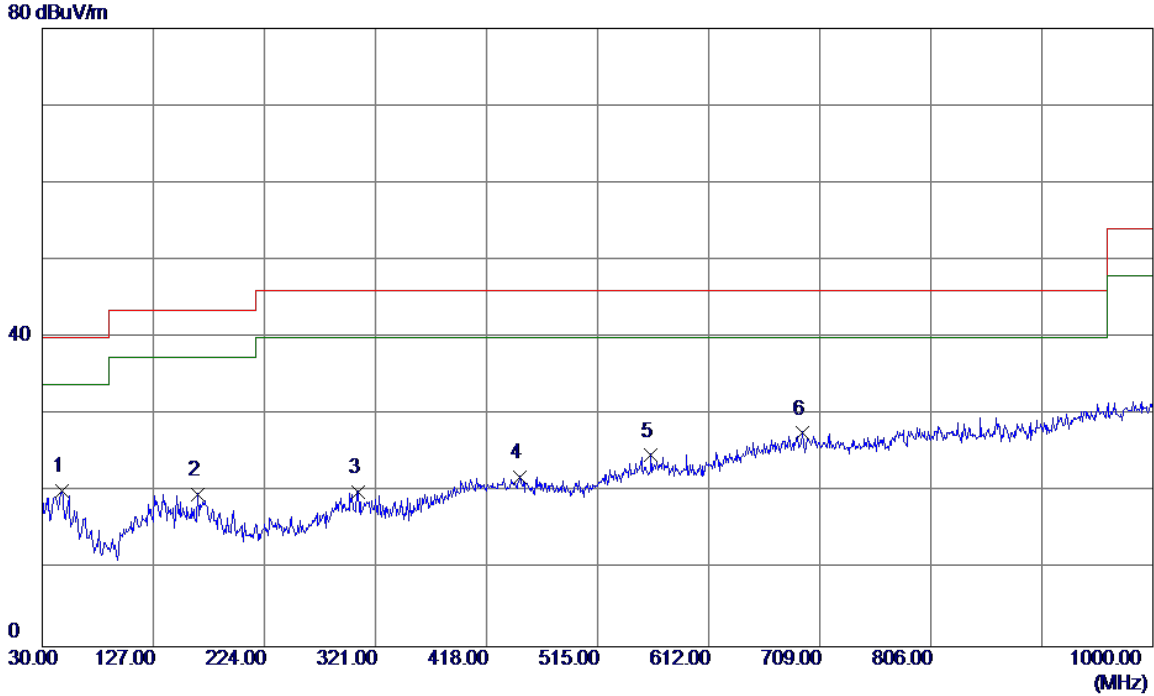

No.	Freq. MHz	Reading Level dBuV/m	Correct Factor dB	Measurement dBuV/m	Limit dBuV/m	Margin dB	Detector	Comment
1	46.9750	32.43	-12.25	20.18	40.00	-19.82	QP	
2	166.2850	31.10	-11.39	19.71	43.50	-23.79	QP	
3	305.4800	30.04	-10.03	20.01	46.00	-25.99	QP	
4	447.5850	29.02	-7.08	21.94	46.00	-24.06	QP	
5	561.5600	29.25	-4.53	24.72	46.00	-21.28	QP	
6 *	693.4800	28.39	-0.79	27.60	46.00	-18.40	QP	

Test Mode: TX 2441MHz \_CH39\_1Mbps

**Horizontal**

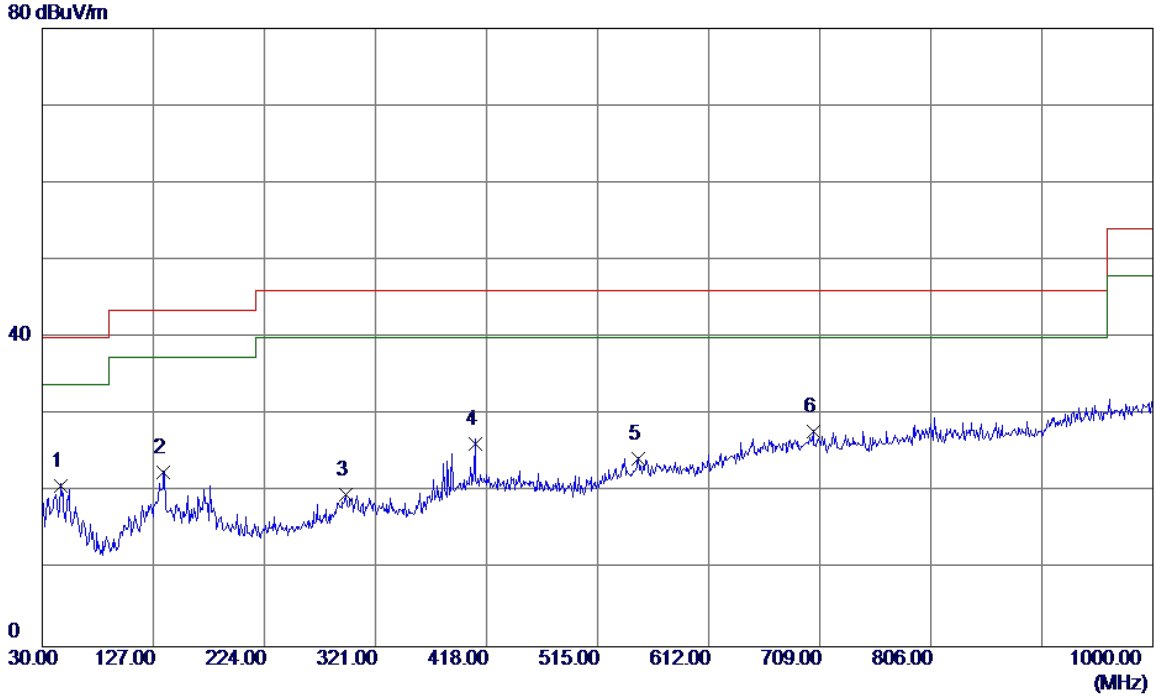

No.	Freq. MHz	Reading Level dBuV/m	Correct Factor dB	Measurement dBuV/m	Limit dBuV/m	Margin dB	Detector	Comment
1	46.0050	32.82	-12.07	20.75	40.00	-19.25	QP	
2	135.7300	34.19	-11.56	22.63	43.50	-20.87	QP	
3	295.2950	29.71	-9.96	19.75	46.00	-26.25	QP	
4	407.8150	33.42	-7.18	26.24	46.00	-19.76	QP	
5	550.8900	28.80	-4.45	24.35	46.00	-21.65	QP	
6 *	703.1800	28.44	-0.66	27.78	46.00	-18.22	QP	

Test Mode: TX 2480MHz \_CH78\_1Mbps

**Vertical**

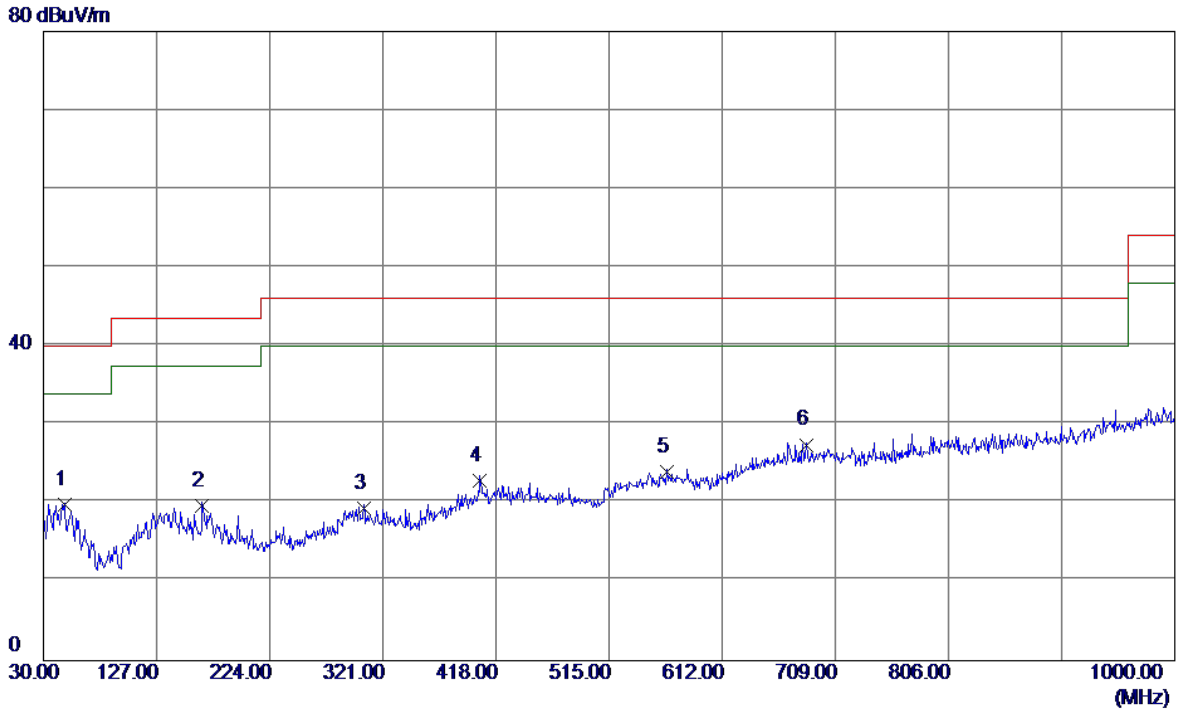

No.	Freq. MHz	Reading Level dBuV/m	Correct Factor dB	Measure ment dBuV/m	Limit dBuV/m	Margin dB	Detector	Comment
1	47.9450	32.21	-12.44	19.77	40.00	-20.23	QP	
2	165.8000	31.09	-11.48	19.61	43.50	-23.89	QP	
3	304.9950	29.35	-10.02	19.33	46.00	-26.67	QP	
4	404.4200	30.07	-7.19	22.88	46.00	-23.12	QP	
5	564.4699	28.55	-4.55	24.00	46.00	-22.00	QP	
6 *	684.2650	28.42	-0.98	27.44	46.00	-18.56	QP	

Test Mode: TX 2480MHz \_CH78\_1Mbps

**Horizontal**

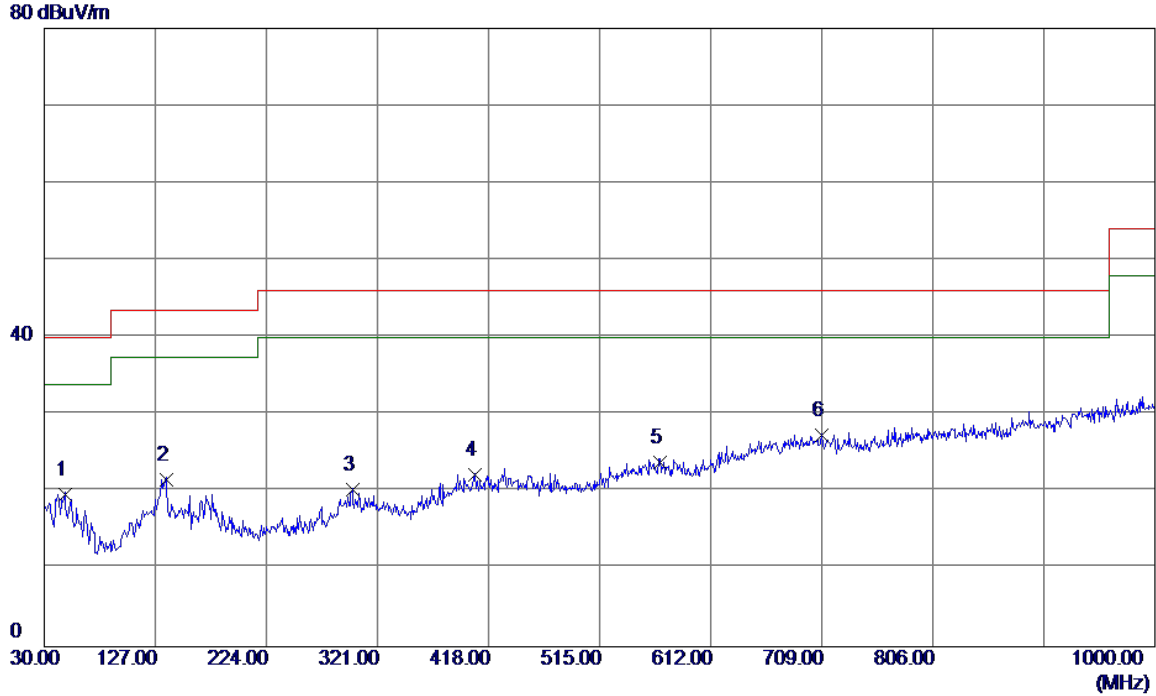

No.	Freq. MHz	Reading Level dBuV/m	Correct Factor dB	Measure ment dBuV/m	Limit dBuV/m	Margin dB	Detector	Comment
1	47.9450	32.13	-12.44	19.69	40.00	-20.31	QP	
2	136.2150	33.18	-11.60	21.58	43.50	-21.92	QP	
3	299.1750	30.25	-9.94	20.31	46.00	-25.69	QP	
4	405.8750	29.41	-7.19	22.22	46.00	-23.78	QP	
5	567.3800	28.37	-4.58	23.79	46.00	-22.21	QP	
6 *	709.4850	28.06	-0.69	27.37	46.00	-18.63	QP	

## ATTACHMENT D - RADIATED EMISSION (ABOVE 1000MHZ)

Test Mode : TX 2402MHz \_CH00\_1Mbps

**Vertical**

120 dBuV/m

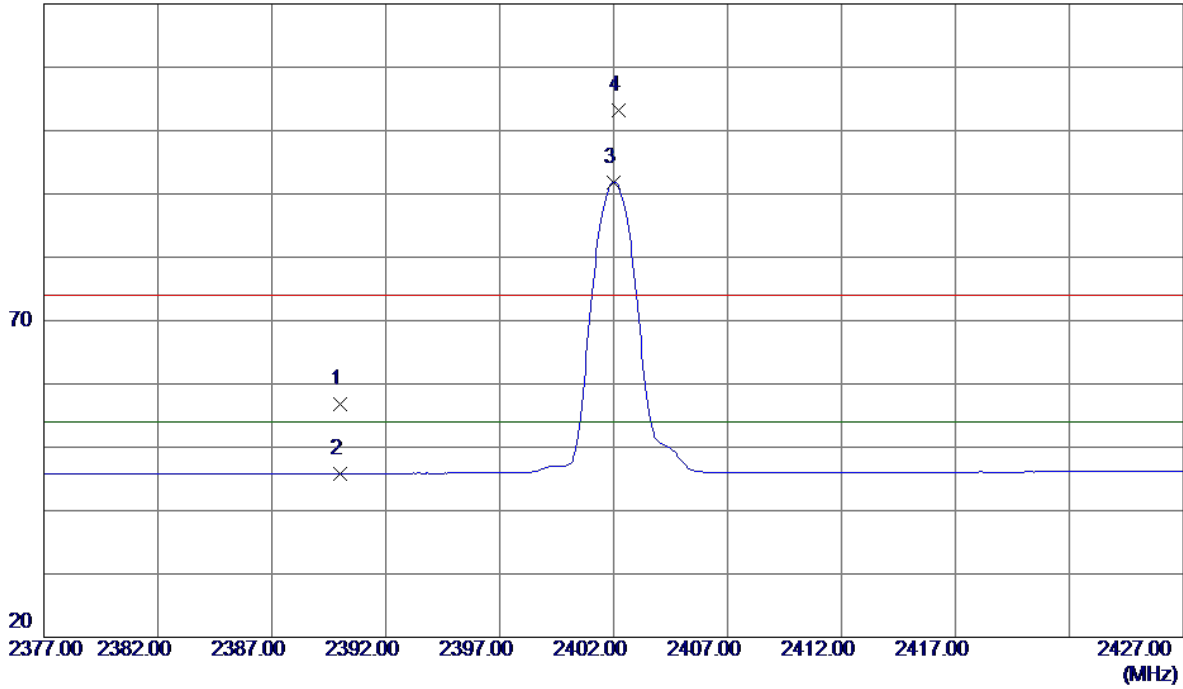

No.	Freq. MHz	Reading Level dBuV/m	Correct Factor dB	Measure ment dBuV/m	Limit dBuV/m	Margin dB	Detector	Comment
1	2390.0000	24.13	32.68	56.81	74.00	-17.19	Peak	
2	2390.0000	13.19	32.68	45.87	54.00	-8.13	AVG	
3 *	2402.0000	59.15	32.69	91.84	54.00	37.84	AVG	No Limit
4	2402.2000	70.48	32.70	103.18	74.00	29.18	Peak	No Limit

Test Mode : TX 2402MHz \_CH00\_1Mbps

**Vertical**

100 dBuV/m



No.	Freq. MHz	Reading Level dBuV/m	Correct Factor dB	Measure ment dBuV/m	Limit dBuV/m	Margin dB	Detector	Comment
1	4803.9000	47.55	5.82	53.37	74.00	-20.63	Peak	
2 *	4804.0000	35.97	5.82	41.79	54.00	-12.21	AVG	

Test Mode : TX 2402MHz \_CH00\_1Mbps

**Horizontal**

120 dBuV/m

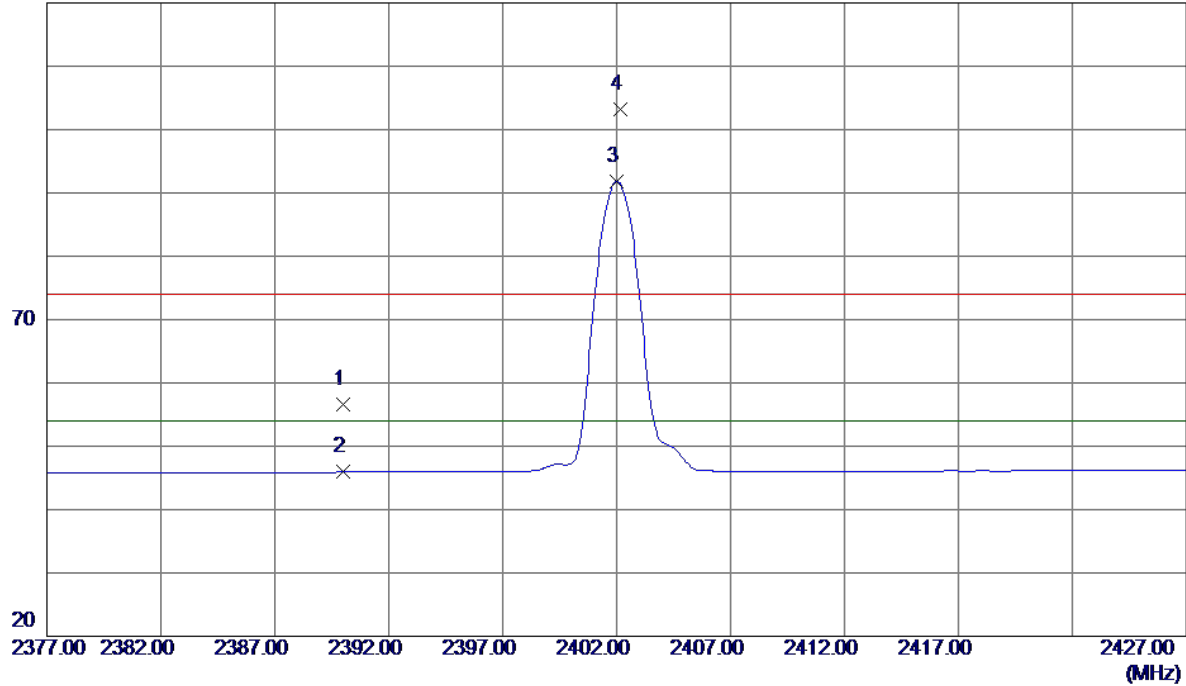

No.	Freq. MHz	Reading Level dBuV/m	Correct Factor dB	Measure ment dBuV/m	Limit dBuV/m	Margin dB	Detector	Comment
1	2390.0000	23.86	32.68	56.54	74.00	-17.46	Peak	
2	2390.0000	13.24	32.68	45.92	54.00	-8.08	AVG	
3 *	2402.0000	59.09	32.69	91.78	54.00	37.78	AVG	No Limit
4	2402.1500	70.43	32.69	103.12	74.00	29.12	Peak	No Limit

Test Mode : TX 2402MHz \_CH00\_1Mbps

**Horizontal**

100 dBuV/m



No.	Freq. MHz	Reading Level dBuV/m	Correct Factor dB	Measure ment dBuV/m	Limit dBuV/m	Margin dB	Detector	Comment
1	4803.9100	46.28	5.82	52.10	74.00	-21.90	Peak	
2 *	4803.9900	34.78	5.82	40.60	54.00	-13.40	AVG	

Test Mode : TX 2441MHz \_CH39\_1Mbps

**Vertical**

120 dBuV/m

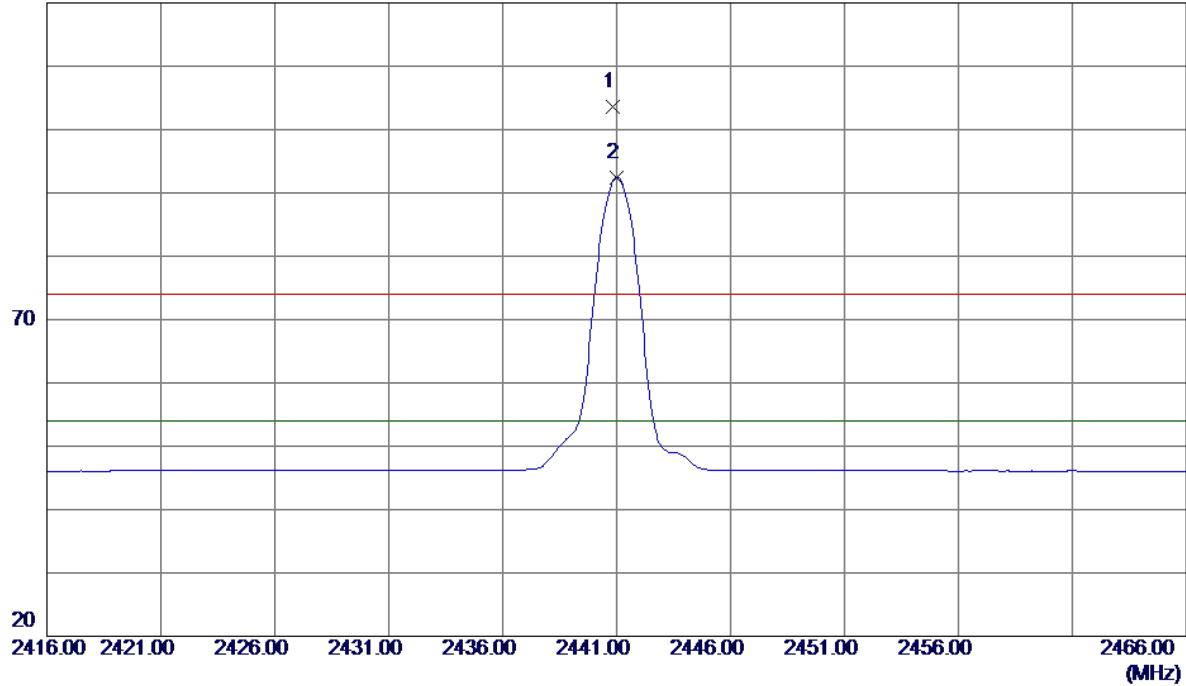

No.	Freq. MHz	Reading Level dBuV/m	Correct Factor dB	Measure ment dBuV/m	Limit dBuV/m	Margin dB	Detector	Comment
1	2440.8500	70.91	32.75	103.66	74.00	29.66	Peak	No Limit
2 *	2441.0000	59.66	32.75	92.41	54.00	38.41	AVG	No Limit

Test Mode : TX 2441MHz \_CH39\_1Mbps

**Vertical**

100 dBuV/m

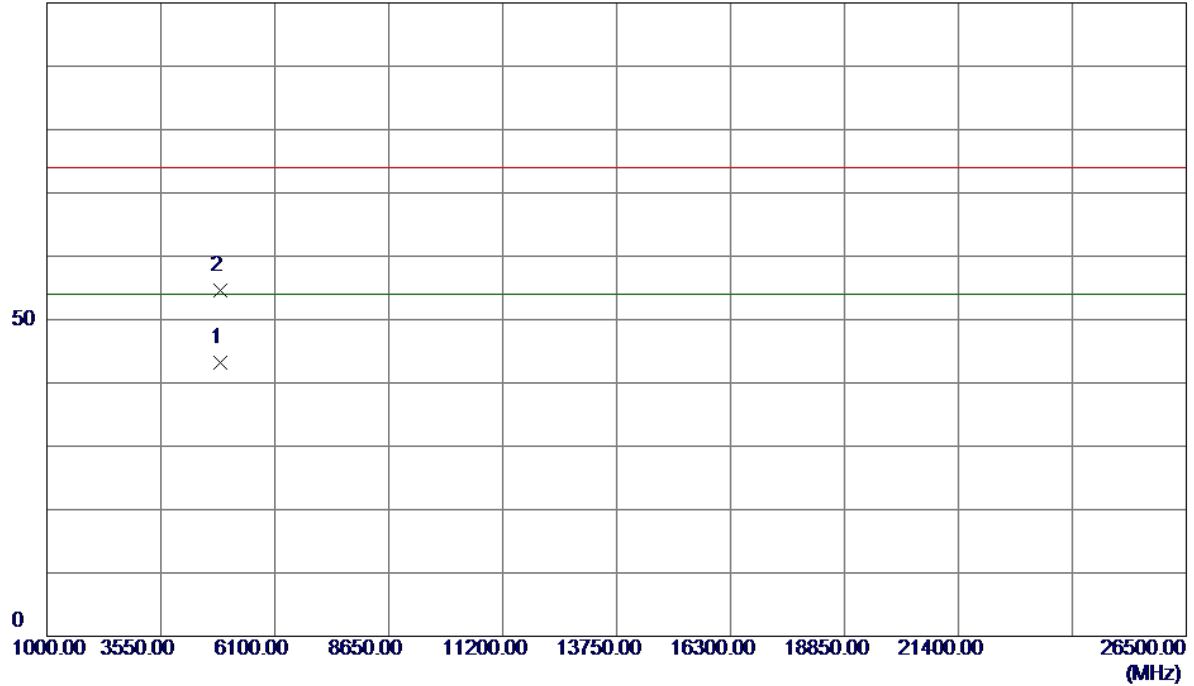

No.	Freq. MHz	Reading Level dBuV/m	Correct Factor dB	Measure ment dBuV/m	Limit dBuV/m	Margin dB	Detector	Comment
1 *	4881.9800	37.23	6.02	43.25	54.00	-10.75	AVG	
2	4882.4700	48.53	6.03	54.56	74.00	-19.44	Peak	

Test Mode : TX 2441MHz \_CH39\_1Mbps

**Horizontal**

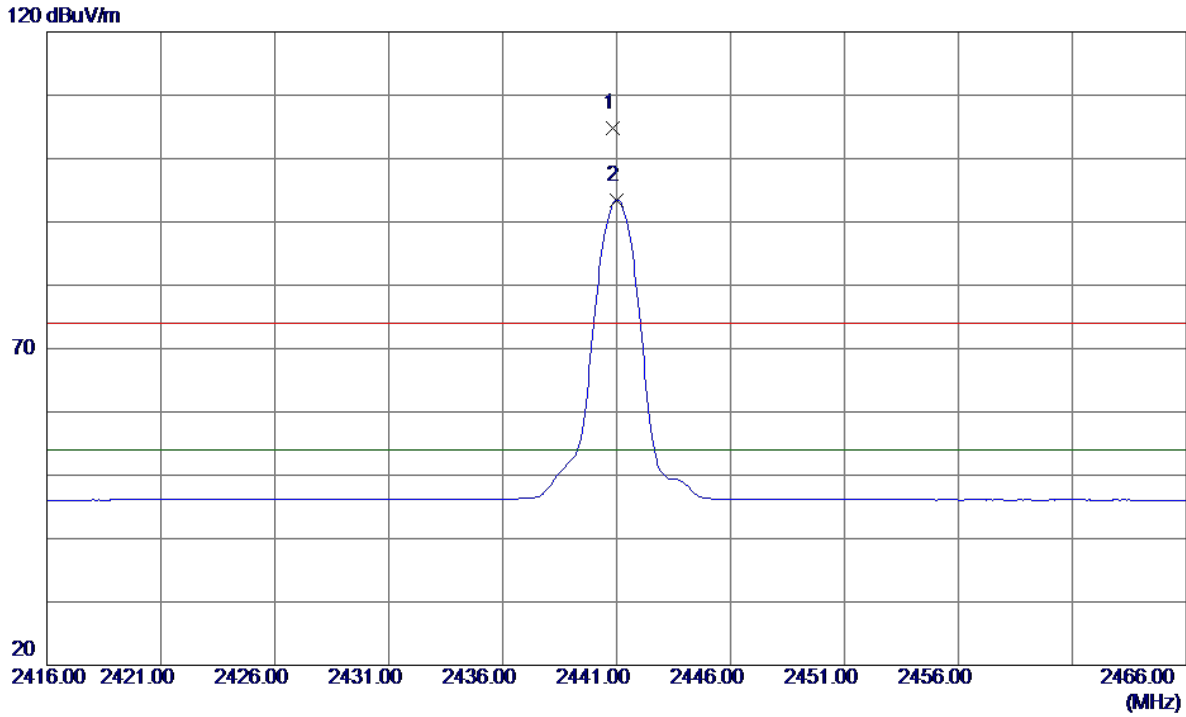

No.	Freq. MHz	Reading Level dBuV/m	Correct Factor dB	Measure ment dBuV/m	Limit dBuV/m	Margin dB	Detector	Comment
1	2440.8500	71.97	32.75	104.72	74.00	30.72	Peak	No Limit
2 *	2441.0000	60.69	32.75	93.44	54.00	39.44	AVG	No Limit

Test Mode : TX 2441MHz \_CH39\_1Mbps

**Horizontal**

100 dBuV/m



No.	Freq. MHz	Reading Level dBuV/m	Correct Factor dB	Measure ment dBuV/m	Limit dBuV/m	Margin dB	Detector	Comment
1	4881.9300	45.17	6.02	51.19	74.00	-22.81	Peak	
2 *	4881.9800	33.55	6.02	39.57	54.00	-14.43	AVG	

Test Mode : TX 2480MHz \_CH78\_1Mbps

**Vertical**

120 dBuV/m

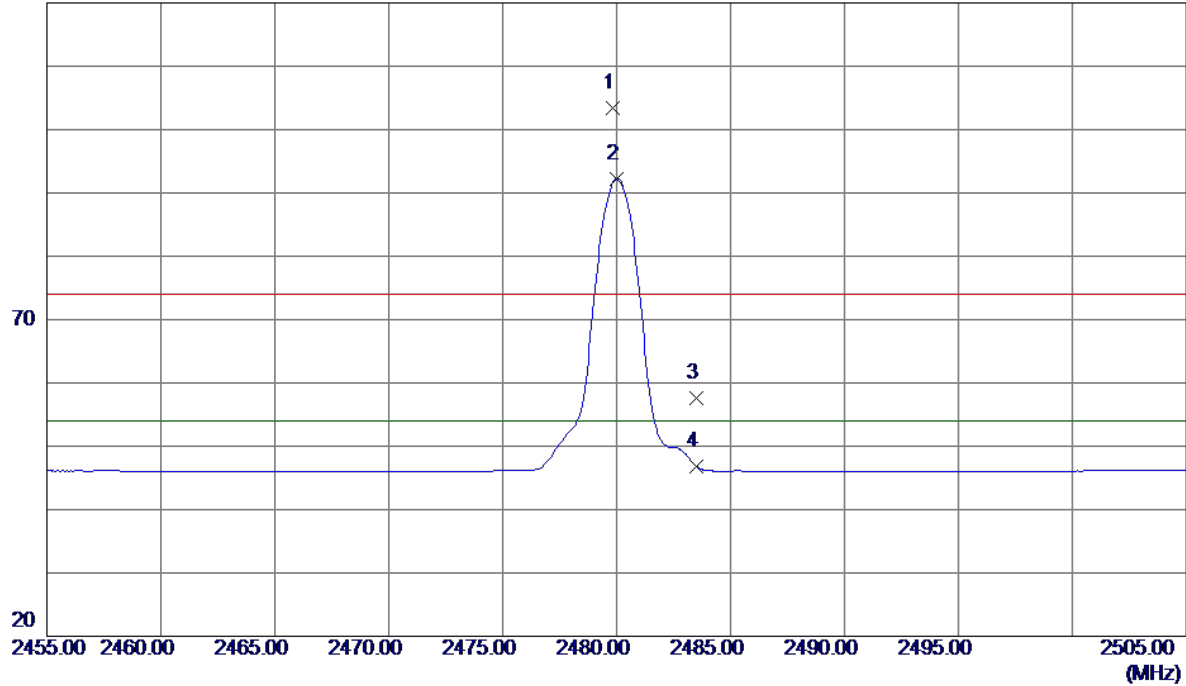

No.	Freq. MHz	Reading Level dBuV/m	Correct Factor dB	Measure ment dBuV/m	Limit dBuV/m	Margin dB	Detector	Comment
1	2479.8500	70.68	32.80	103.48	74.00	29.48	Peak	No Limit
2 *	2480.0000	59.44	32.80	92.24	54.00	38.24	AVG	No Limit
3	2483.5000	24.78	32.81	57.59	74.00	-16.41	Peak	
4	2483.5000	14.06	32.81	46.87	54.00	-7.13	AVG	

Test Mode : TX 2480MHz \_CH78\_1Mbps

**Vertical**

100 dBuV/m



No.	Freq. MHz	Reading Level dBuV/m	Correct Factor dB	Measure ment dBuV/m	Limit dBuV/m	Margin dB	Detector	Comment
1	4959.7000	48.57	6.23	54.80	74.00	-19.20	Peak	
2 *	4959.9800	37.80	6.23	44.03	54.00	-9.97	AVG	

Test Mode : TX 2480MHz \_CH78\_1Mbps

**Horizontal**

120 dBuV/m

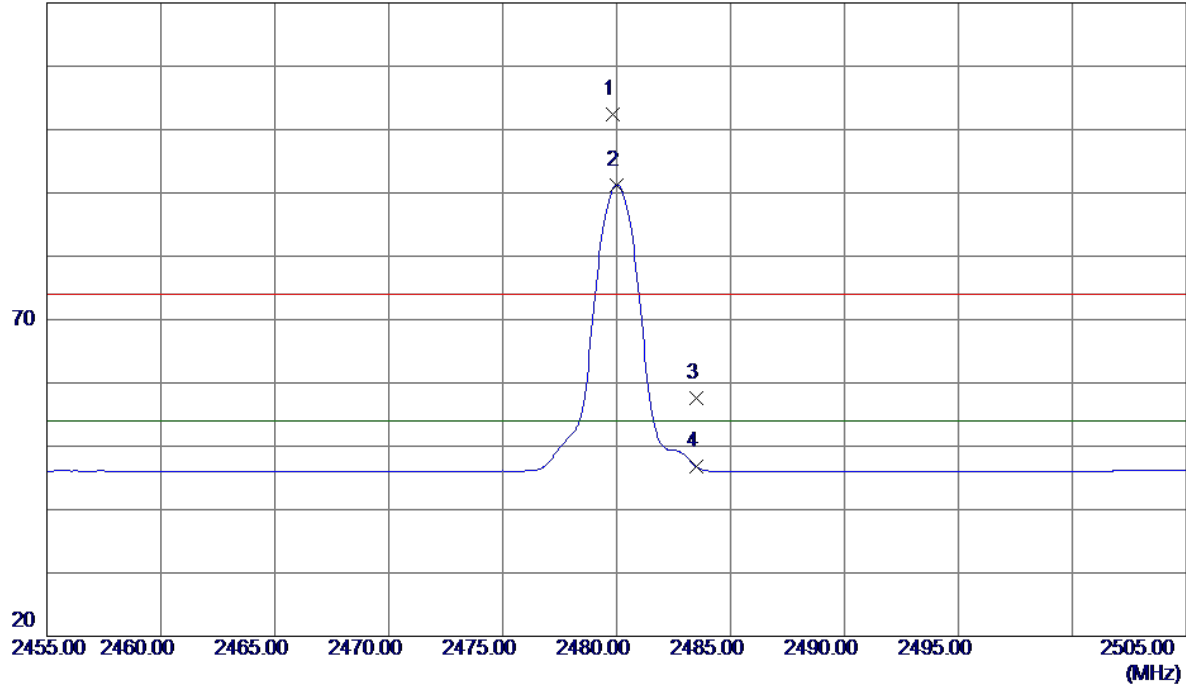

No.	Freq. MHz	Reading Level dBuV/m	Correct Factor dB	Measure ment dBuV/m	Limit dBuV/m	Margin dB	Detector	Comment
1	2479.8500	69.60	32.80	102.40	74.00	28.40	Peak	No Limit
2 *	2480.0000	58.41	32.80	91.21	54.00	37.21	AVG	No Limit
3	2483.5000	24.87	32.81	57.68	74.00	-16.32	Peak	
4	2483.5000	13.94	32.81	46.75	54.00	-7.25	AVG	

Test Mode : TX 2480MHz \_CH78\_1Mbps

**Horizontal**

100 dBuV/m



No.	Freq. MHz	Reading Level dBuV/m	Correct Factor dB	Measure ment dBuV/m	Limit dBuV/m	Margin dB	Detector	Comment
1	4959.9100	44.10	6.23	50.33	74.00	-23.67	Peak	
2 *	4959.9800	32.85	6.23	39.08	54.00	-14.92	AVG	

Test Mode : TX 2402MHz \_CH00\_3Mbps

**Vertical**

120 dBuV/m

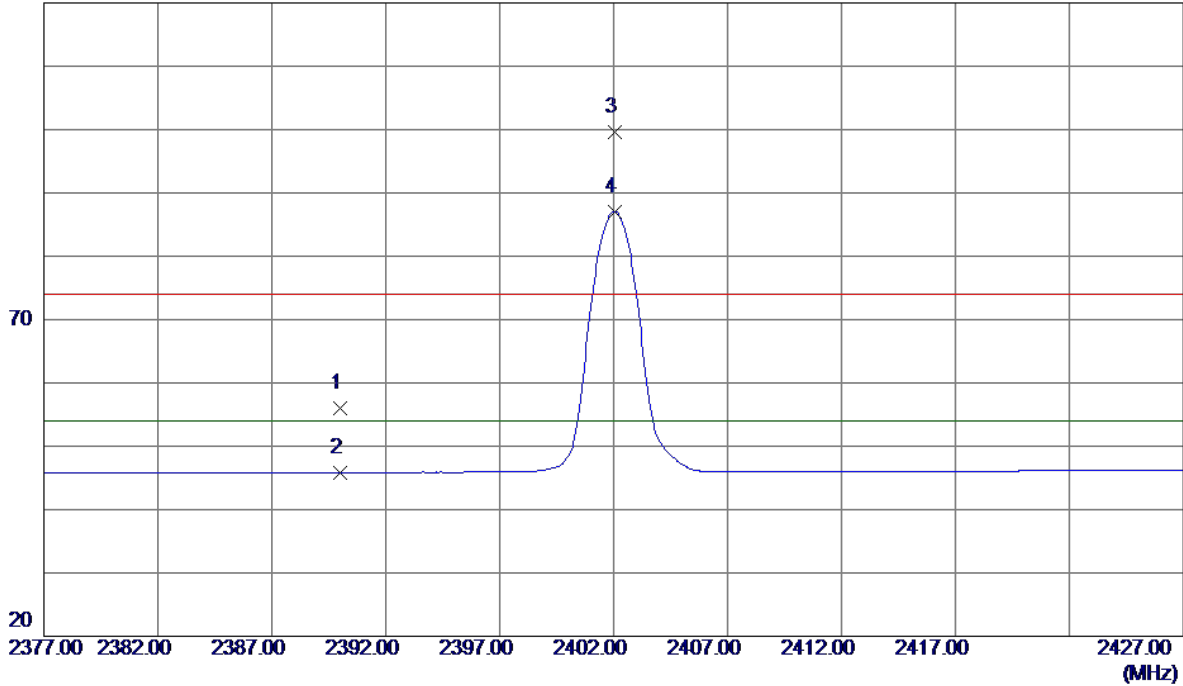

No.	Freq. MHz	Reading Level dBuV/m	Correct Factor dB	Measure ment dBuV/m	Limit dBuV/m	Margin dB	Detector	Comment
1	2390.0000	23.27	32.68	55.95	74.00	-18.05	Peak	
2	2390.0000	13.18	32.68	45.86	54.00	-8.14	AVG	
3	2402.0500	66.88	32.69	99.57	74.00	25.57	Peak	No Limit
4 *	2402.0500	54.37	32.69	87.06	54.00	33.06	AVG	No Limit

Test Mode : TX 2402MHz \_CH00\_3Mbps

**Vertical**

100 dBuV/m



No.	Freq. MHz	Reading Level dBuV/m	Correct Factor dB	Measure ment dBuV/m	Limit dBuV/m	Margin dB	Detector	Comment
1 *	4804.0200	32.26	5.82	38.08	54.00	-15.92	AVG	
2	4804.4000	45.10	5.82	50.92	74.00	-23.08	Peak	

Test Mode : TX 2402MHz \_CH00\_3Mbps

Horizontal

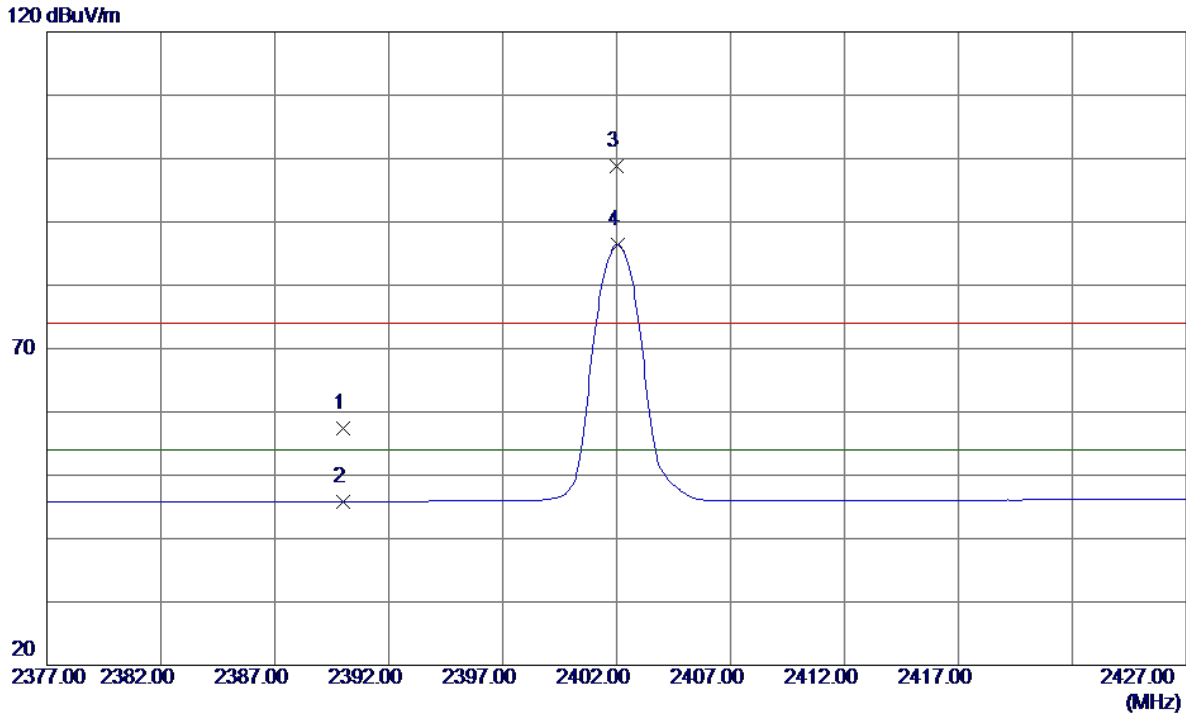

No.	Freq. MHz	Reading Level dBuV/m	Correct Factor dB	Measure ment dBuV/m	Limit dBuV/m	Margin dB	Detector	Comment
1	2390.0000	24.64	32.68	57.32	74.00	-16.68	Peak	
2	2390.0000	13.17	32.68	45.85	54.00	-8.15	AVG	
3	2402.0000	66.19	32.69	98.88	74.00	24.88	Peak	No Limit
4 *	2402.0500	53.70	32.69	86.39	54.00	32.39	AVG	No Limit

Test Mode : TX 2402MHz \_CH00\_3Mbps

**Horizontal**

100 dBuV/m

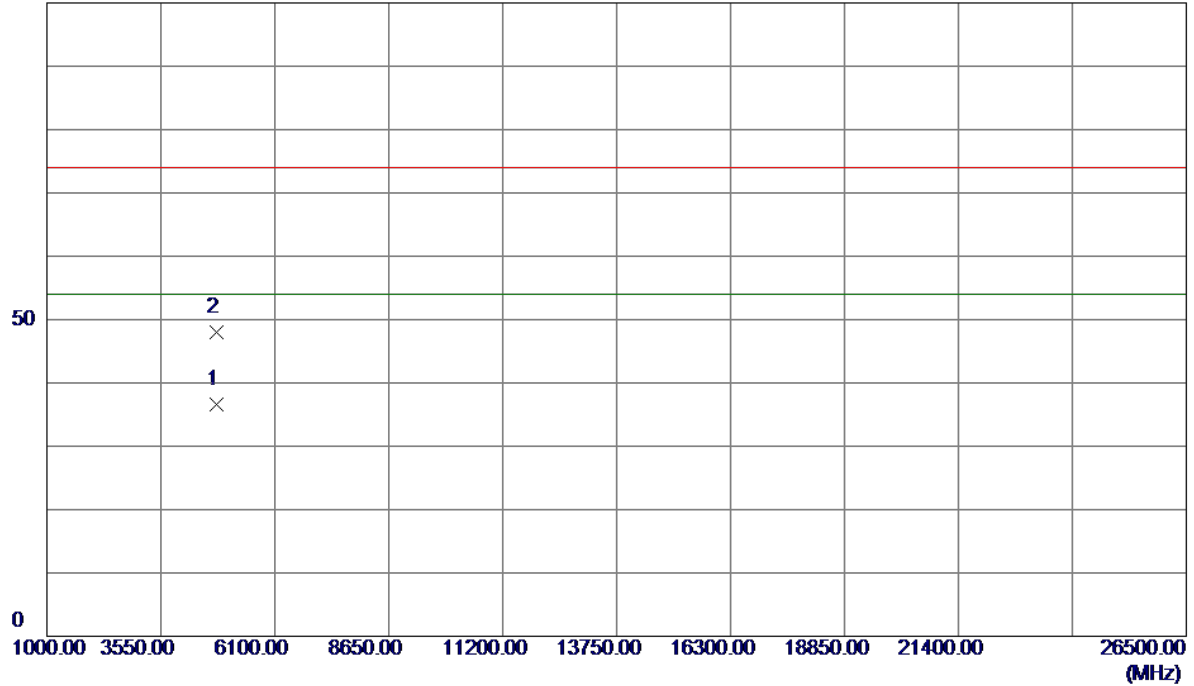

No.	Freq. MHz	Reading Level dBuV/m	Correct Factor dB	Measure ment dBuV/m	Limit dBuV/m	Margin dB	Detector	Comment
1 *	4804.0099	30.74	5.82	36.56	54.00	-17.44	AVG	
2	4804.0400	42.23	5.82	48.05	74.00	-25.95	Peak	

Test Mode : TX 2441MHz \_CH39\_3Mbps

**Vertical**

120 dBuV/m

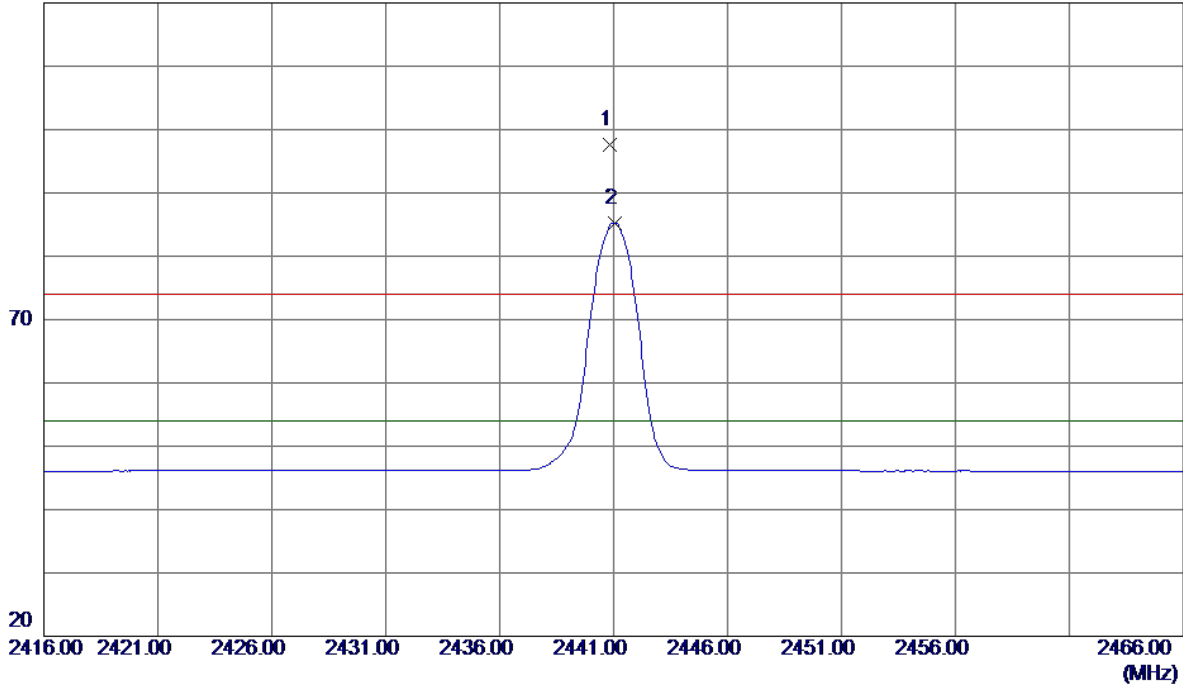

No.	Freq. MHz	Reading Level dBuV/m	Correct Factor dB	Measure ment dBuV/m	Limit dBuV/m	Margin dB	Detector	Comment
1	2440.8500	64.86	32.75	97.61	74.00	23.61	Peak	No Limit
2 *	2441.0500	52.54	32.75	85.29	54.00	31.29	AVG	No Limit

Test Mode : TX 2441MHz \_CH39\_3Mbps

**Vertical**

100 dBuV/m

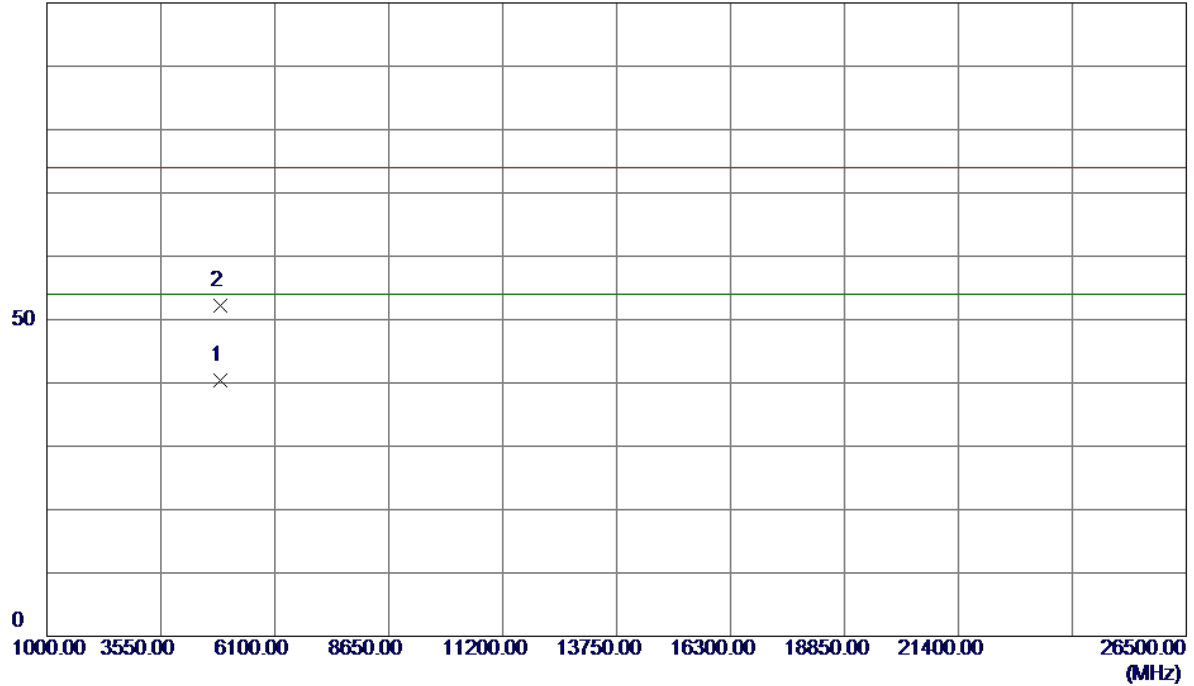

No.	Freq. MHz	Reading Level dBuV/m	Correct Factor dB	Measure ment dBuV/m	Limit dBuV/m	Margin dB	Detector	Comment
1 *	4881.9900	34.31	6.02	40.33	54.00	-13.67	AVG	
2	4882.2700	46.08	6.03	52.11	74.00	-21.89	Peak	

Test Mode : TX 2441MHz \_CH39\_3Mbps

**Horizontal**

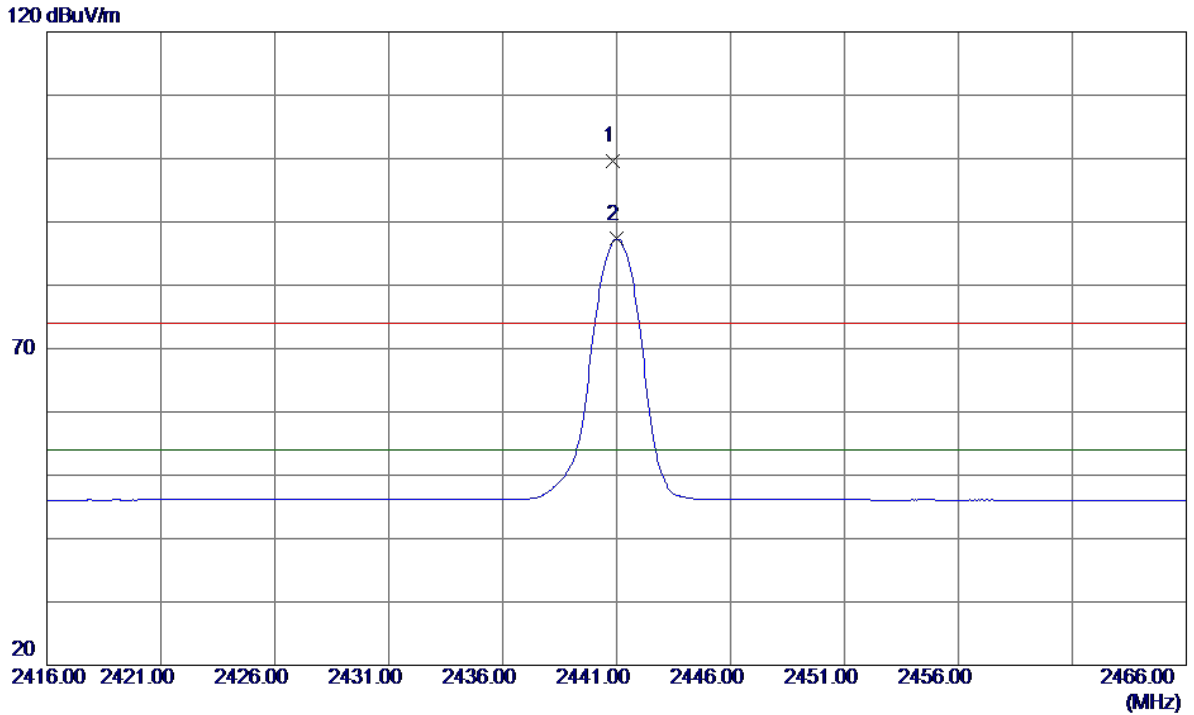

No.	Freq. MHz	Reading Level dBuV/m	Correct Factor dB	Measure ment dBuV/m	Limit dBuV/m	Margin dB	Detector	Comment
1	2440.8500	66.90	32.75	99.65	74.00	25.65	Peak	No Limit
2 *	2441.0000	54.55	32.75	87.30	54.00	33.30	AVG	No Limit

Test Mode : TX 2441MHz \_CH39\_3Mbps

**Horizontal**

100 dBuV/m

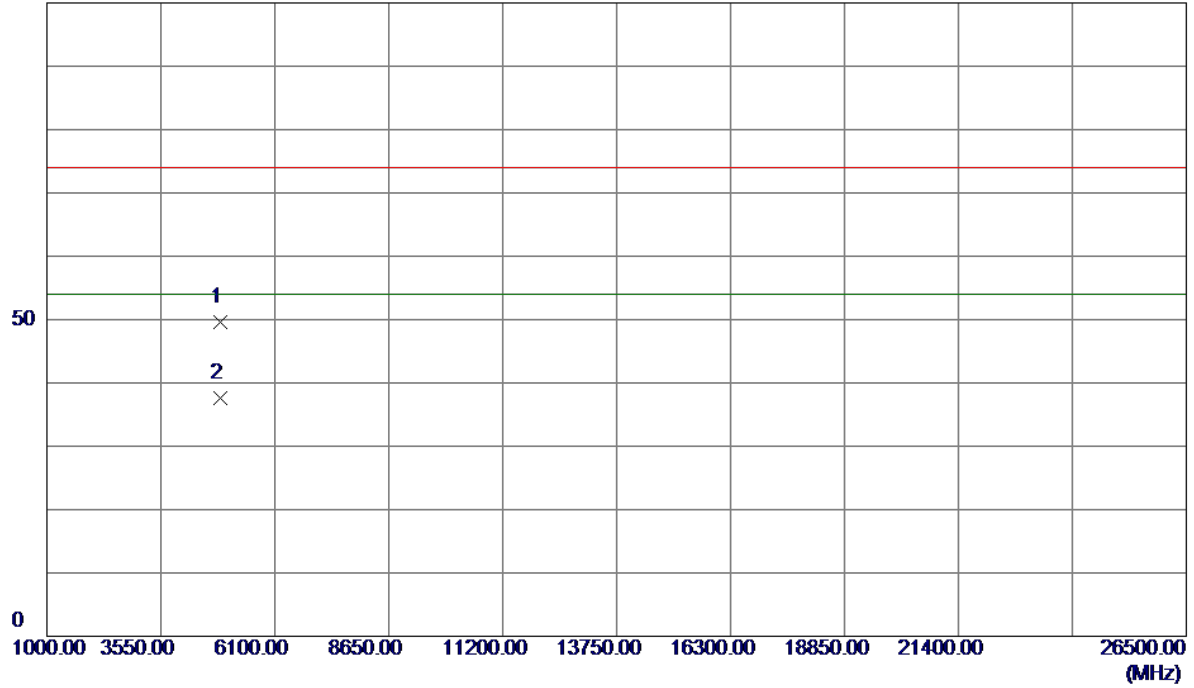

No.	Freq. MHz	Reading Level dBuV/m	Correct Factor dB	Measure ment dBuV/m	Limit dBuV/m	Margin dB	Detector	Comment
1	4881.5900	43.61	6.02	49.63	74.00	-24.37	Peak	
2 *	4881.9700	31.62	6.02	37.64	54.00	-16.36	AVG	

Test Mode : TX 2480MHz \_CH78\_3Mbps

**Vertical**

120 dBuV/m

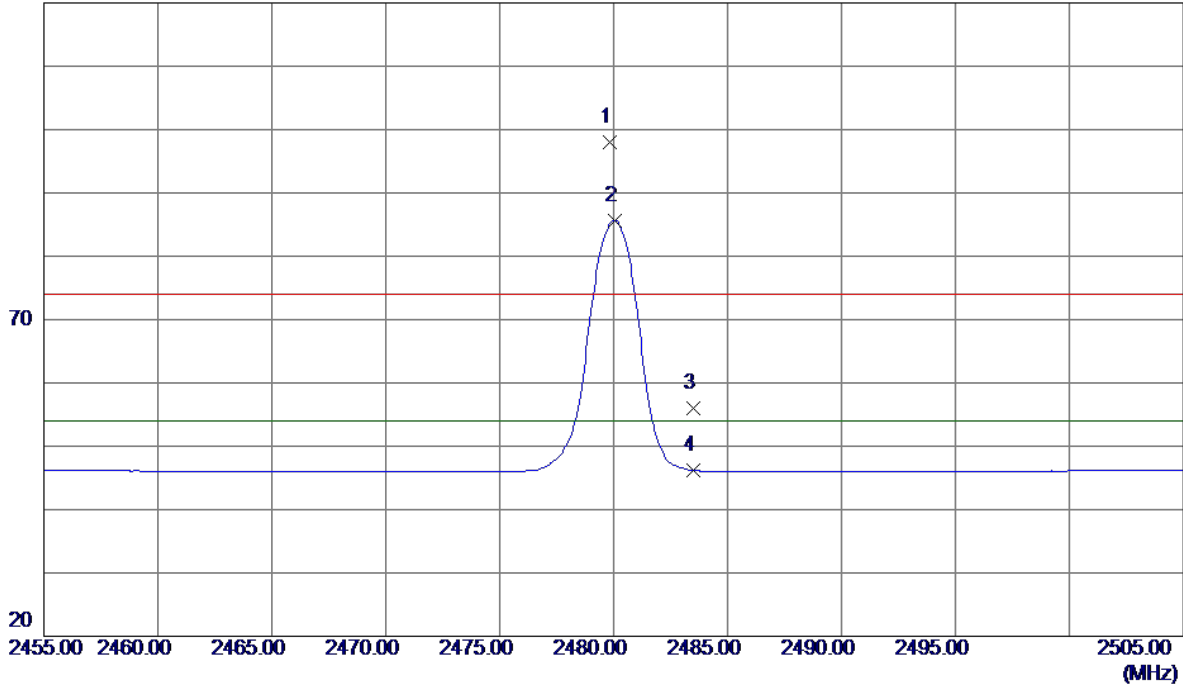

No.	Freq. MHz	Reading Level dBuV/m	Correct Factor dB	Measure ment dBuV/m	Limit dBuV/m	Margin dB	Detector	Comment
1	2479.8500	65.11	32.80	97.91	74.00	23.91	Peak	No Limit
2 *	2480.0500	52.88	32.80	85.68	54.00	31.68	AVG	No Limit
3	2483.5000	23.18	32.81	55.99	74.00	-18.01	Peak	
4	2483.5000	13.36	32.81	46.17	54.00	-7.83	AVG	

Test Mode : TX 2480MHz \_CH78\_3Mbps

**Vertical**

100 dBuV/m



No.	Freq. MHz	Reading Level dBuV/m	Correct Factor dB	Measure ment dBuV/m	Limit dBuV/m	Margin dB	Detector	Comment
1	4959.8000	46.81	6.23	53.04	74.00	-20.96	Peak	
2 *	4959.9900	34.78	6.23	41.01	54.00	-12.99	AVG	

Test Mode : TX 2480MHz \_CH78\_3Mbps

**Horizontal**

120 dBuV/m

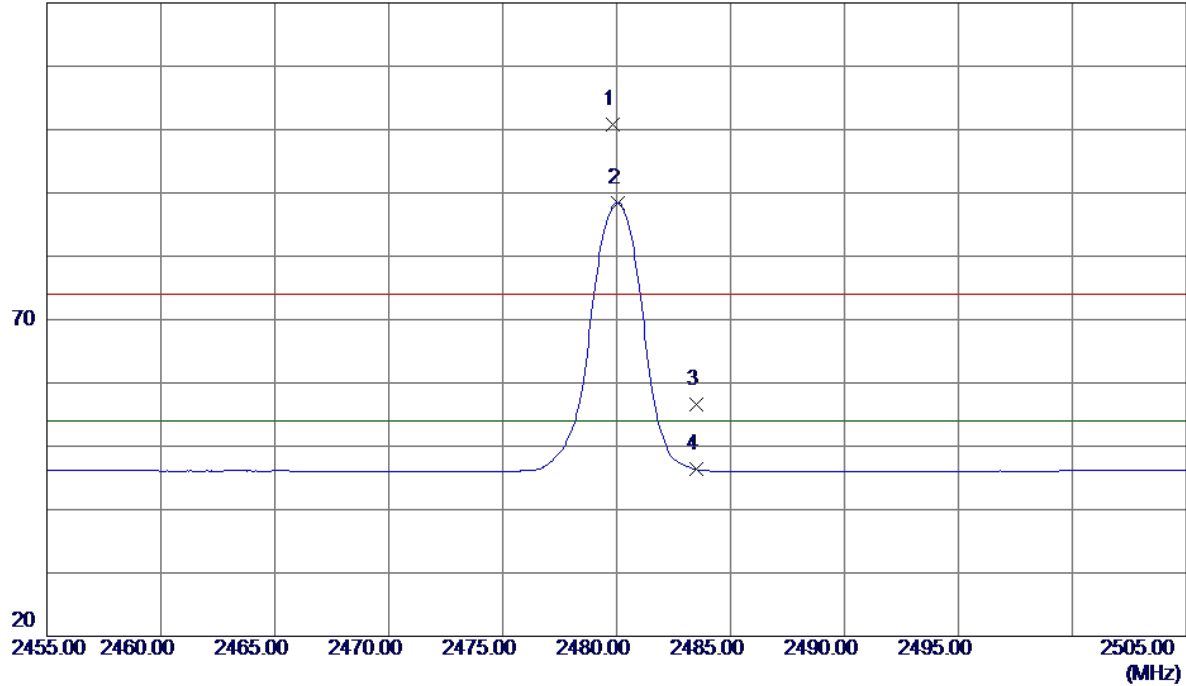

No.	Freq. MHz	Reading Level dBuV/m	Correct Factor dB	Measure ment dBuV/m	Limit dBuV/m	Margin dB	Detector	Comment
1	2479.8500	67.93	32.80	100.73	74.00	26.73	Peak	No Limit
2 *	2480.0500	55.68	32.80	88.48	54.00	34.48	AVG	No Limit
3	2483.5000	23.85	32.81	56.66	74.00	-17.34	Peak	
4	2483.5000	13.50	32.81	46.31	54.00	-7.69	AVG	

Test Mode : TX 2480MHz \_CH78\_3Mbps

**Horizontal**

100 dBuV/m



No.	Freq. MHz	Reading Level dBuV/m	Correct Factor dB	Measure ment dBuV/m	Limit dBuV/m	Margin dB	Detector	Comment
1 *	4959.9800	31.05	6.23	37.28	54.00	-16.72	AVG	
2	4960.1300	42.37	6.23	48.60	74.00	-25.40	Peak	

## ATTACHMENT E - NUMBER OF HOPPING CHANNEL

**Test Mode**                      **Hopping Mode\_1Mbps**  
 Number of Hopping Channel                      79

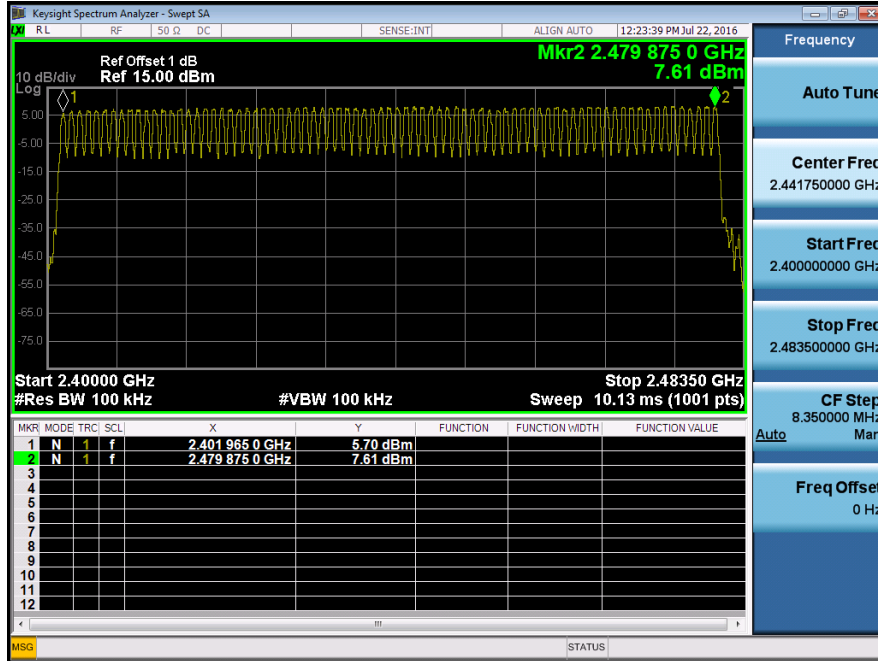

**Test Mode**                      **Hopping Mode\_3Mbps**  
 Number of Hopping Channel                      79

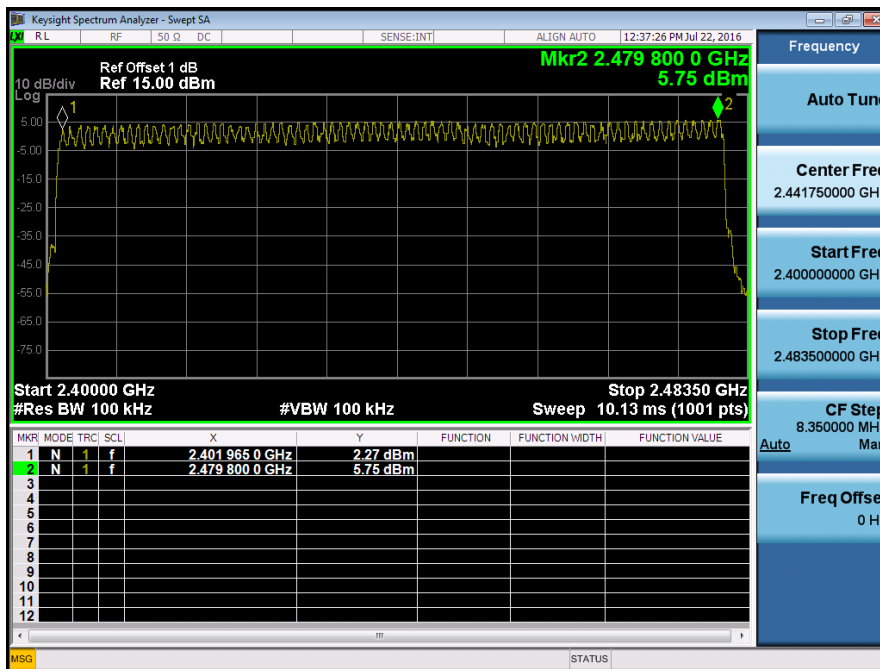

## ATTACHMENT F - AVERAGE TIME OF OCCUPANCY

Test Mode :	TX Mode_1Mbps
-------------	---------------

Data Packet	Frequency (MHz)	Pulse Duration (ms)	Dwell Time (s)	Limits (s)	Test Result
DH5	2402	2.9000	0.3093	0.4000	Pass
DH3	2402	1.6400	0.1749	0.4000	Pass
DH1	2402	0.3952	0.0422	0.4000	Pass
DH5	2441	2.8800	0.3072	0.4000	Pass
DH3	2441	1.6400	0.1749	0.4000	Pass
DH1	2441	0.3851	0.0411	0.4000	Pass
DH5	2480	2.9000	0.3093	0.4000	Pass
DH3	2480	1.6500	0.1760	0.4000	Pass
DH1	2480	0.3851	0.0411	0.4000	Pass

### CH00-DH1

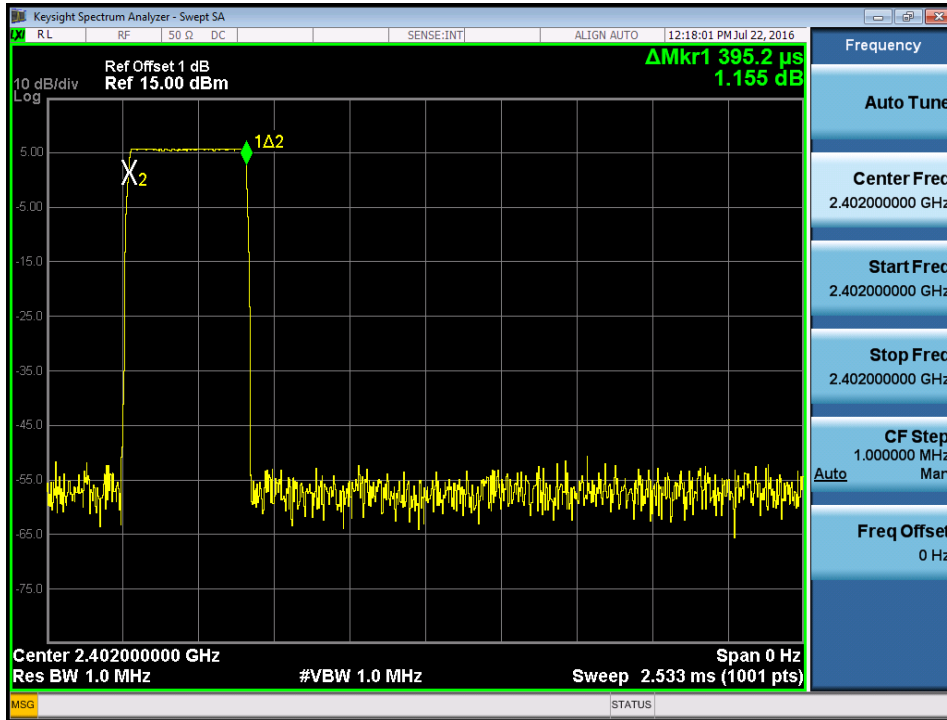

### CH00-DH3

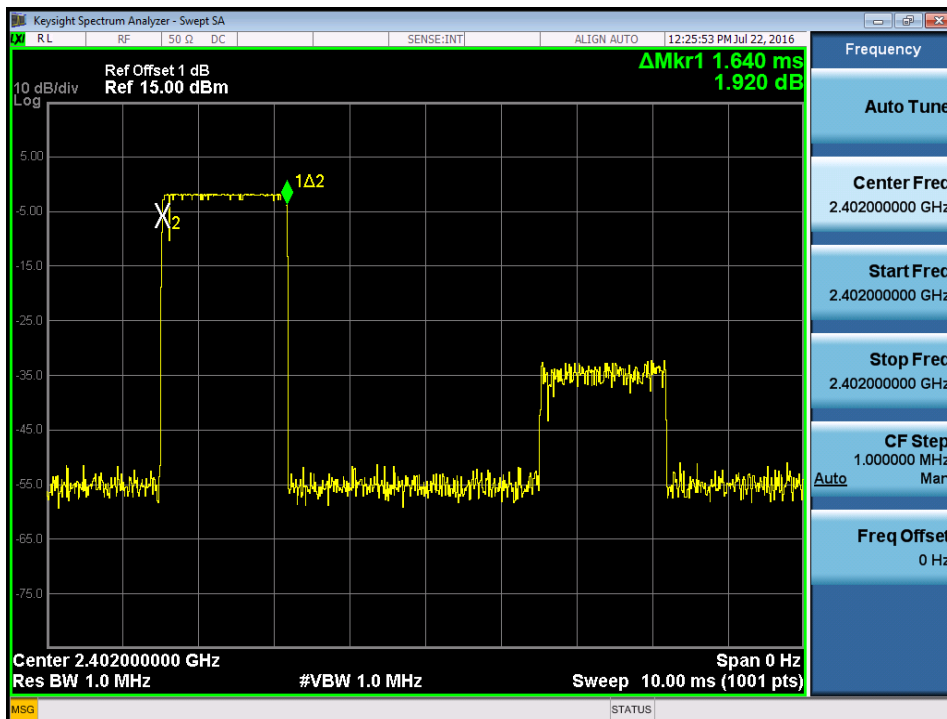

CH00-DH5

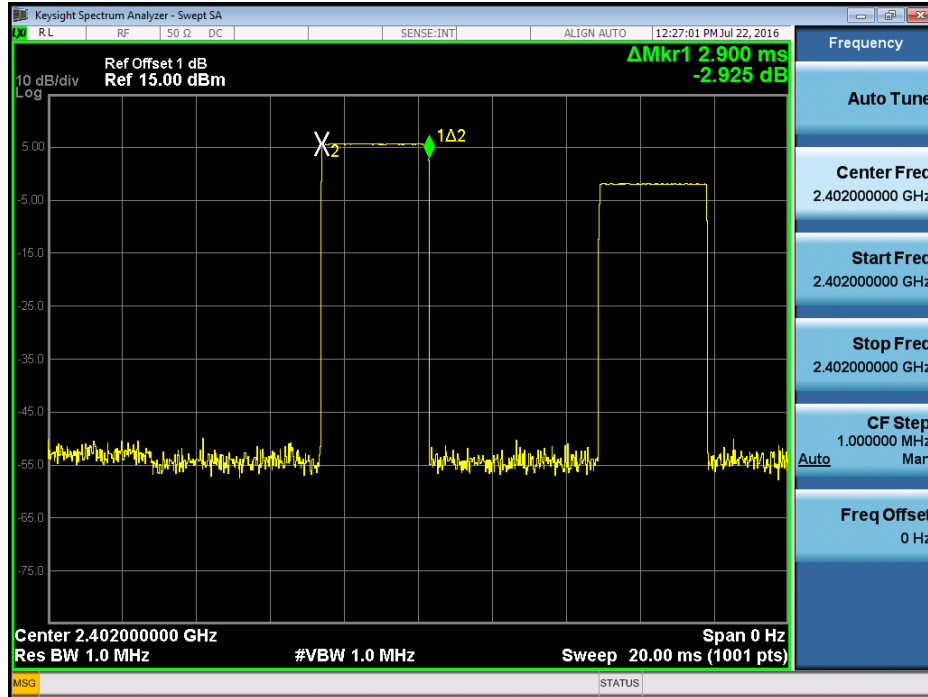

CH39-DH1

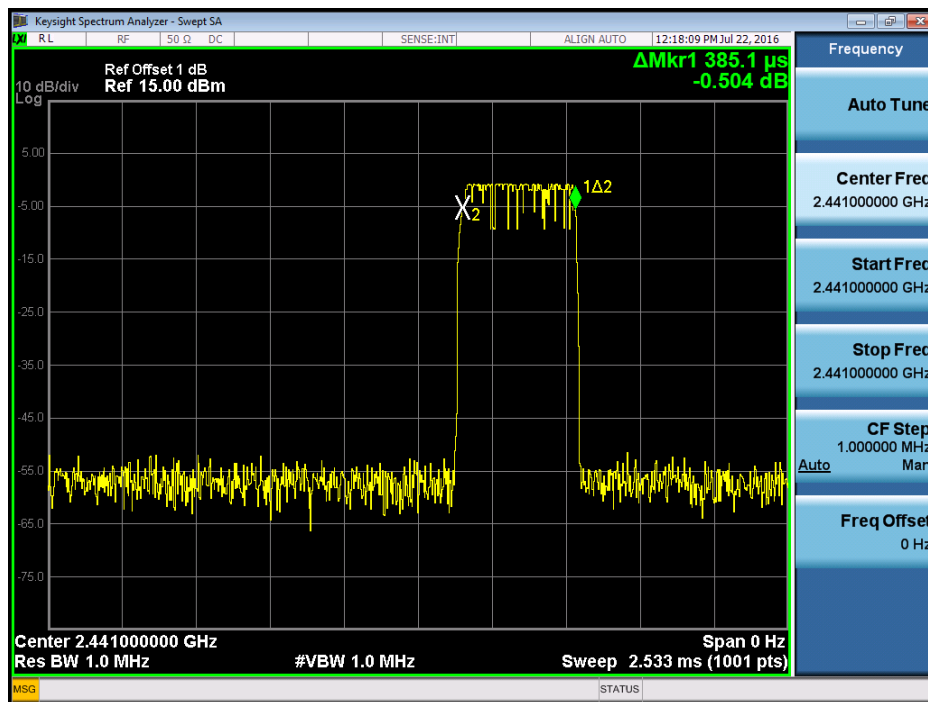

### CH39-DH3

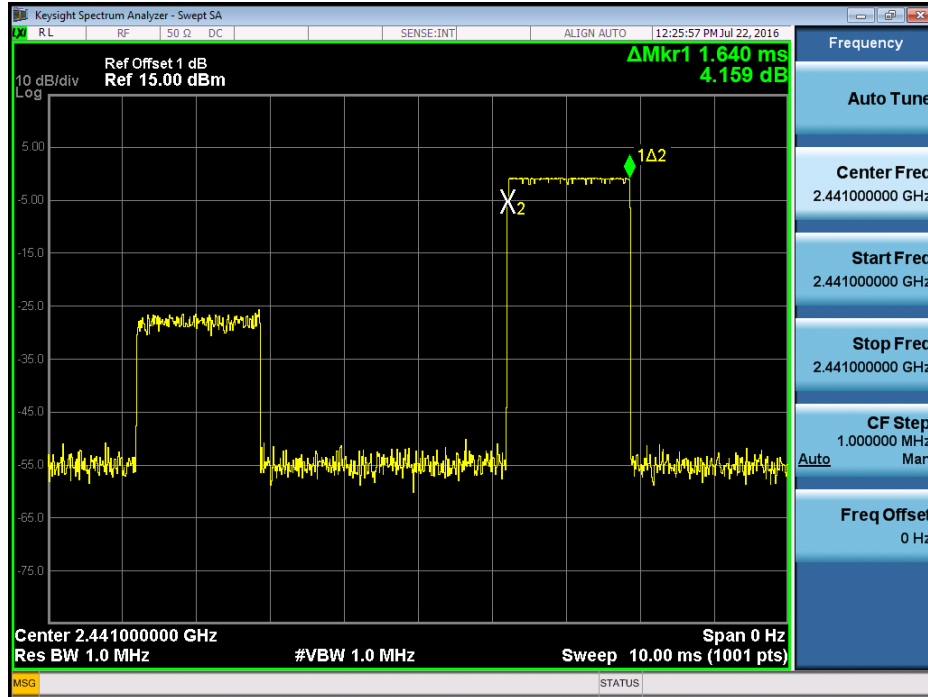

### CH39-DH5

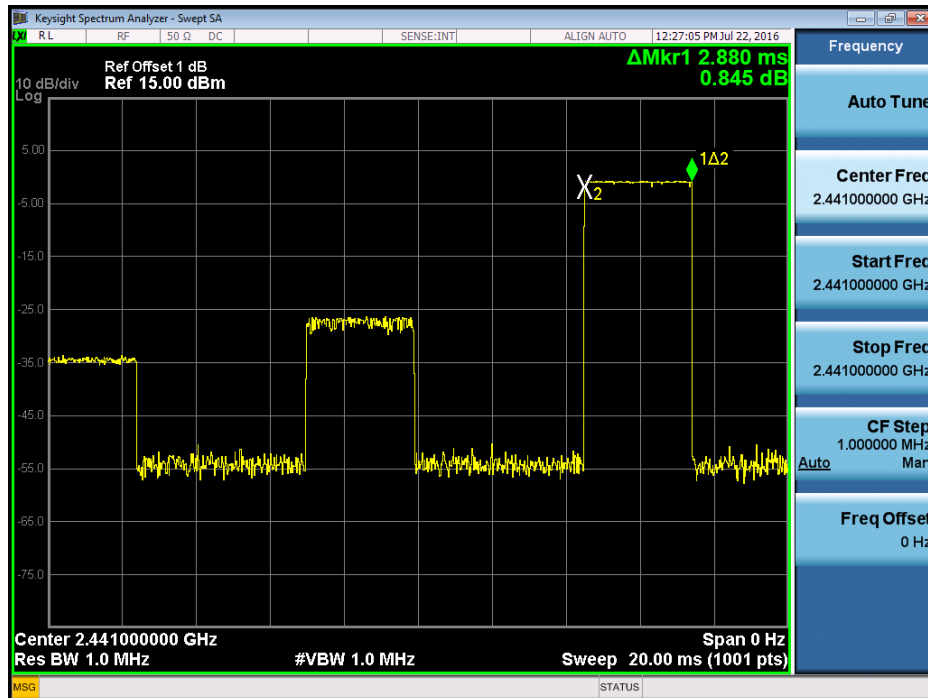

### CH78-DH1

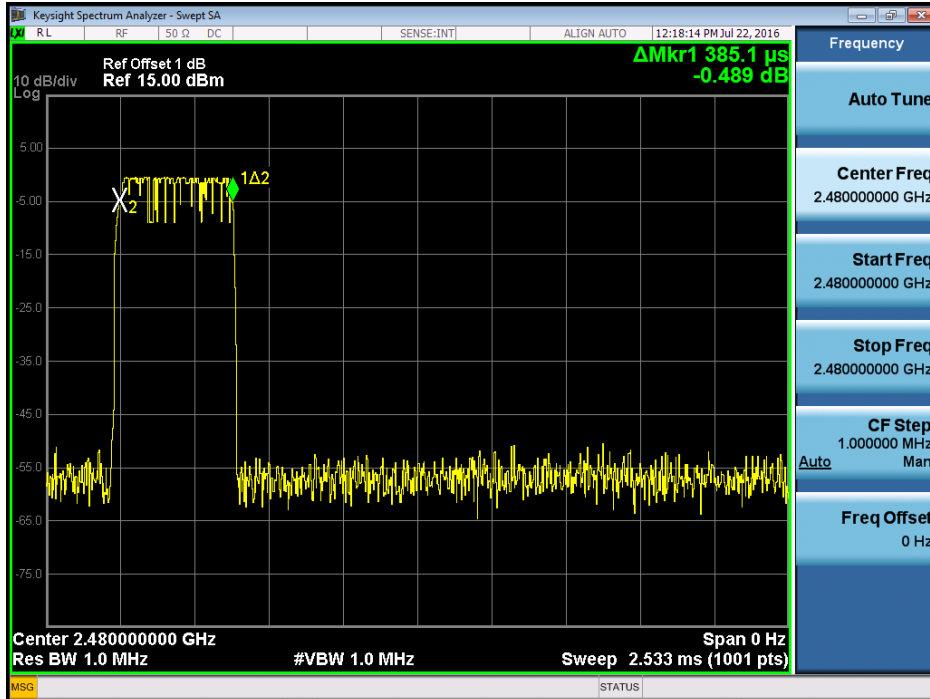

### CH78-DH3

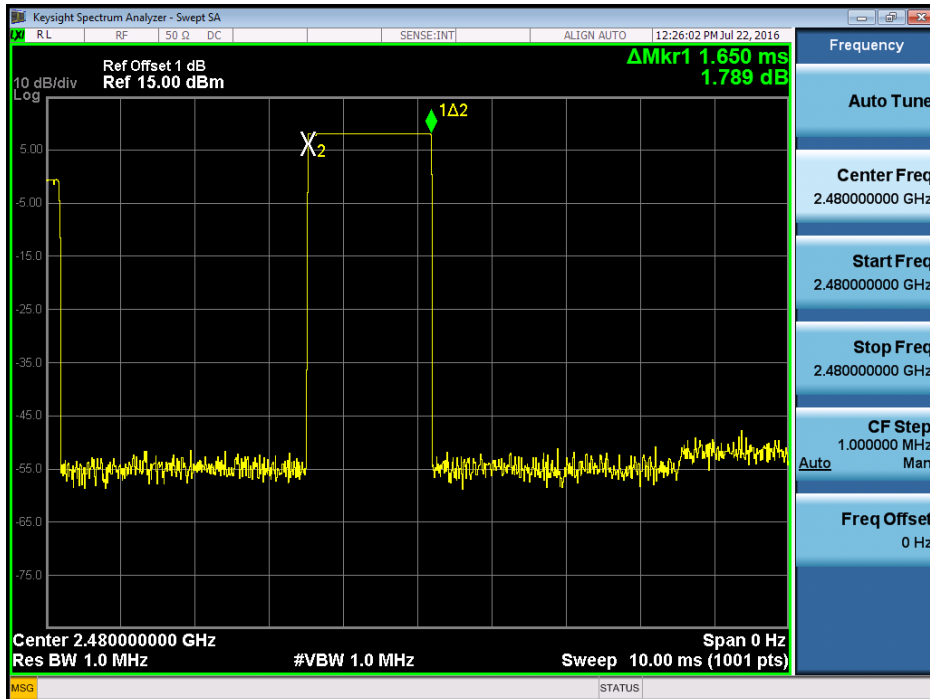

CH78-DH5

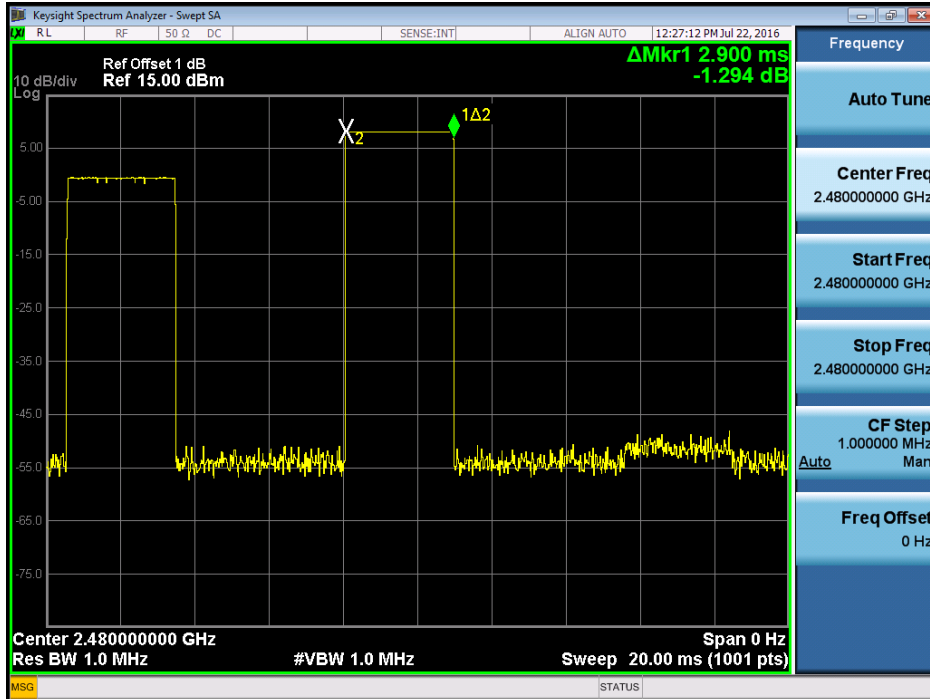

Test Mode :	TX Mode_3Mbps
-------------	---------------

Data Packet	Frequency	Pulse Duration(ms)	Dwell Time(s)	Limits(s)	Test Result
DH5	2402	2.8800	0.3072	0.4000	Pass
DH3	2402	1.6600	0.1771	0.4000	Pass
DH1	2402	0.4079	0.0435	0.4000	Pass
DH5	2441	2.9200	0.3115	0.4000	Pass
DH3	2441	1.6600	0.1771	0.4000	Pass
DH1	2441	0.4079	0.0435	0.4000	Pass
DH5	2480	2.8800	0.3072	0.4000	Pass
DH3	2480	1.6300	0.1739	0.4000	Pass
DH1	2480	0.3724	0.0397	0.4000	Pass

CH00-DH1

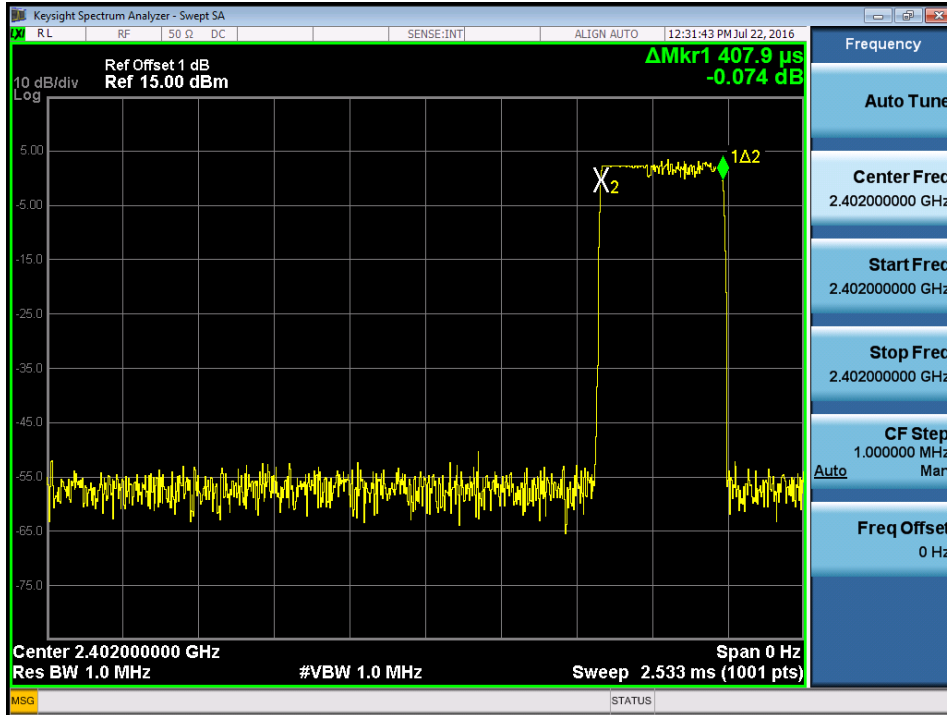

CH00-DH3

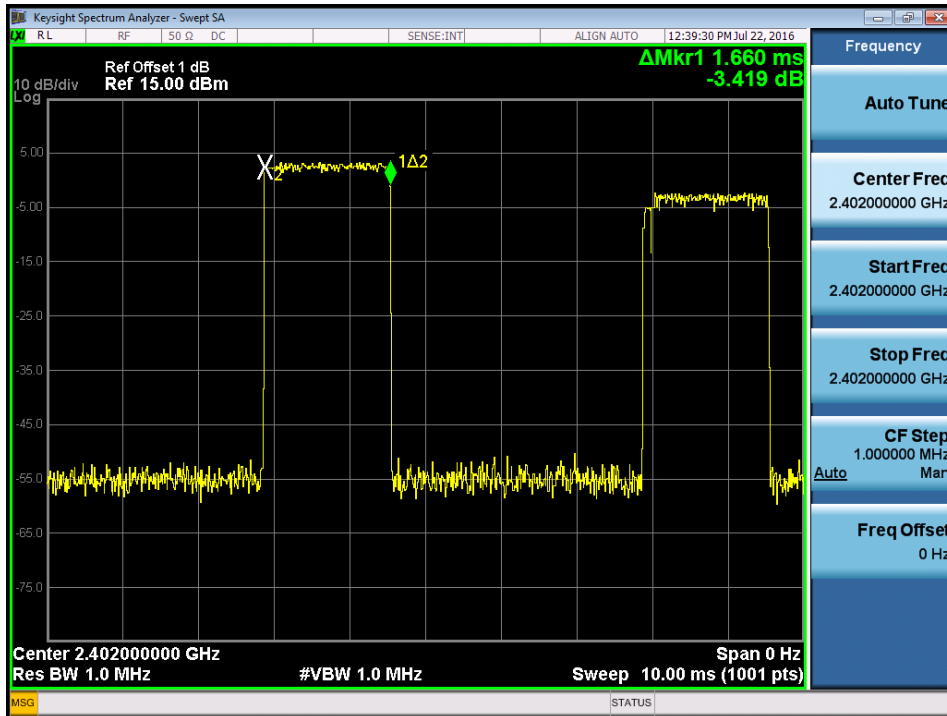

CH00-DH5

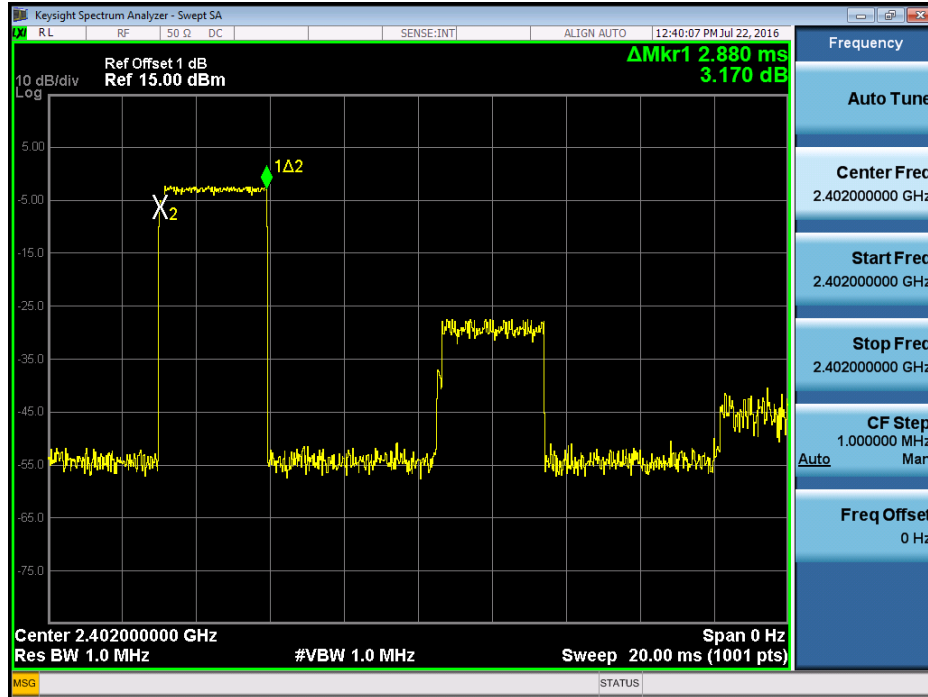

CH39-DH1

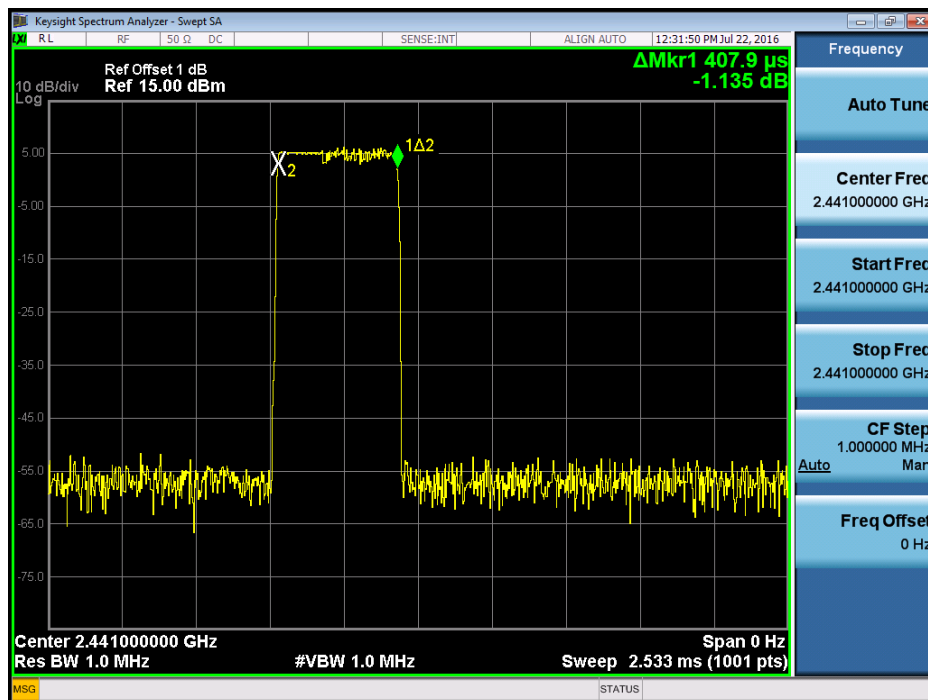

### CH39-DH3

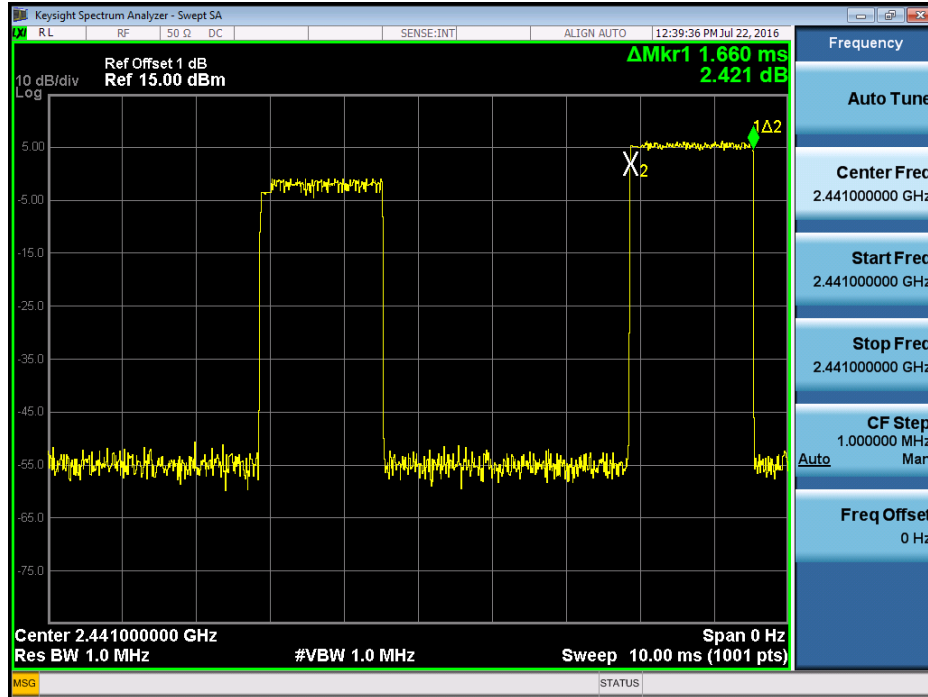

### CH39-DH5

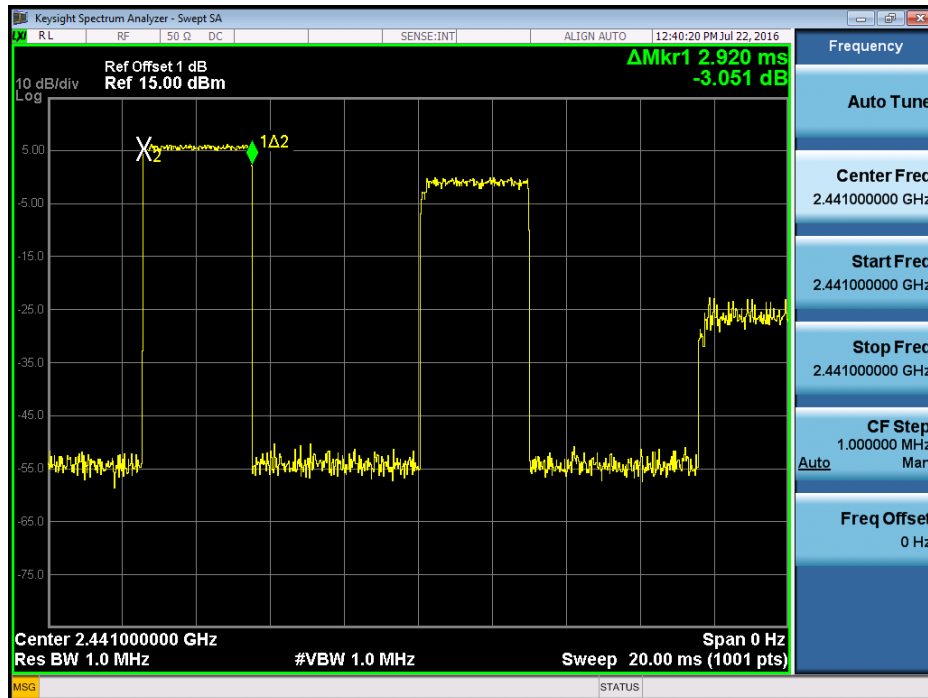

CH78-DH1

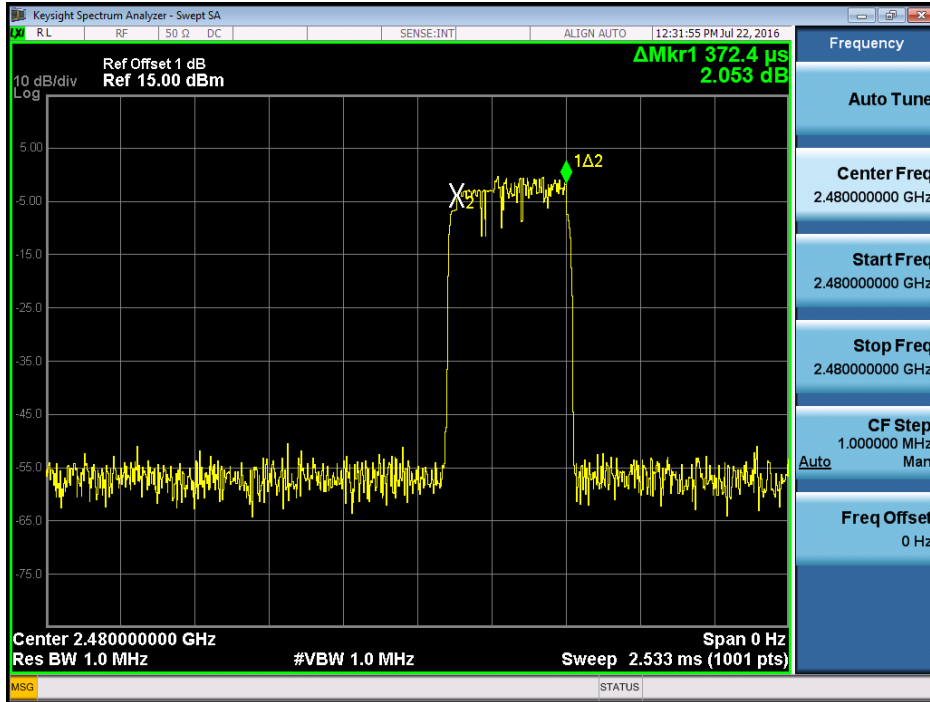

CH78-DH3

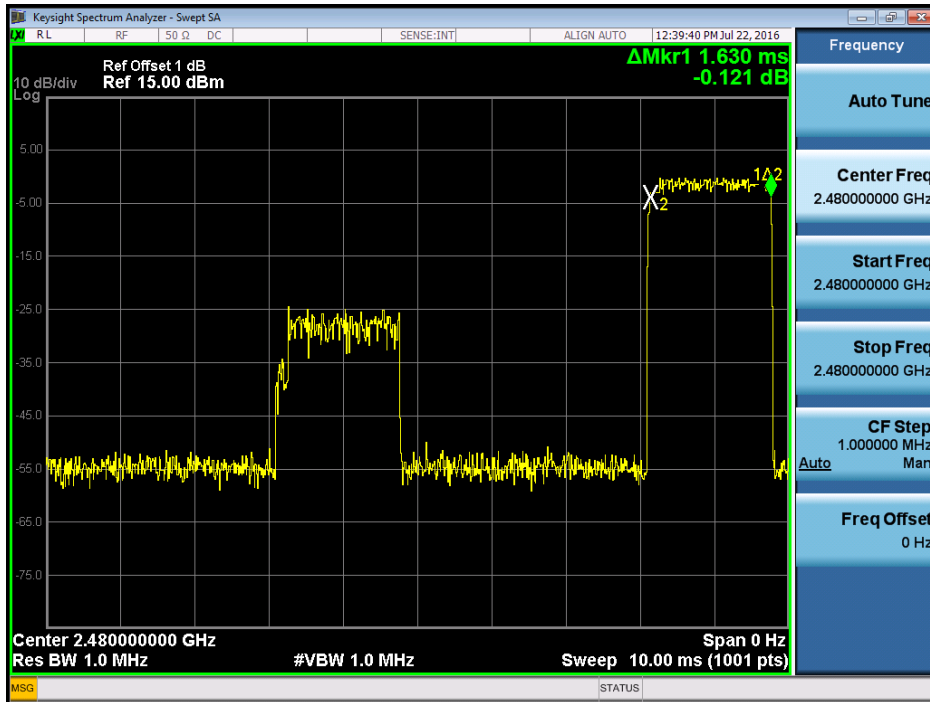

CH78-DH5

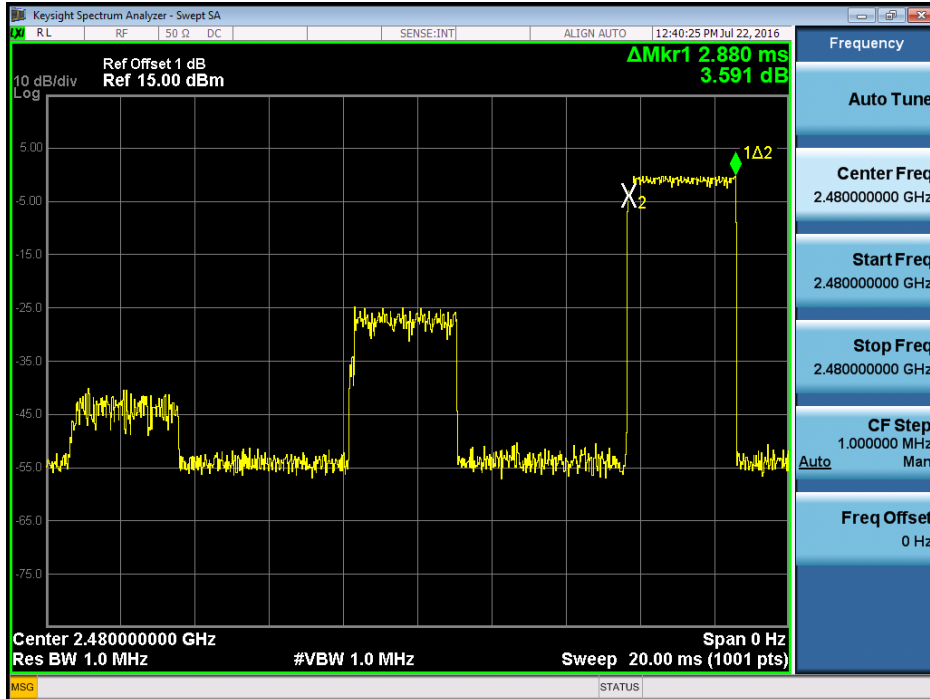

# ATTACHMENT G - HOPPING CHANNEL SEPARATION MEASUREMENT

Test Mode : Hopping on \_1Mbps

Frequency (MHz)	Channel Separation (MHz)	2/3 of 20dB Bandwidth (MHz)	Test Result
2402	0.990	0.608	Pass
2441	1.008	0.583	Pass
2480	1.008	0.591	Pass

**CH00**

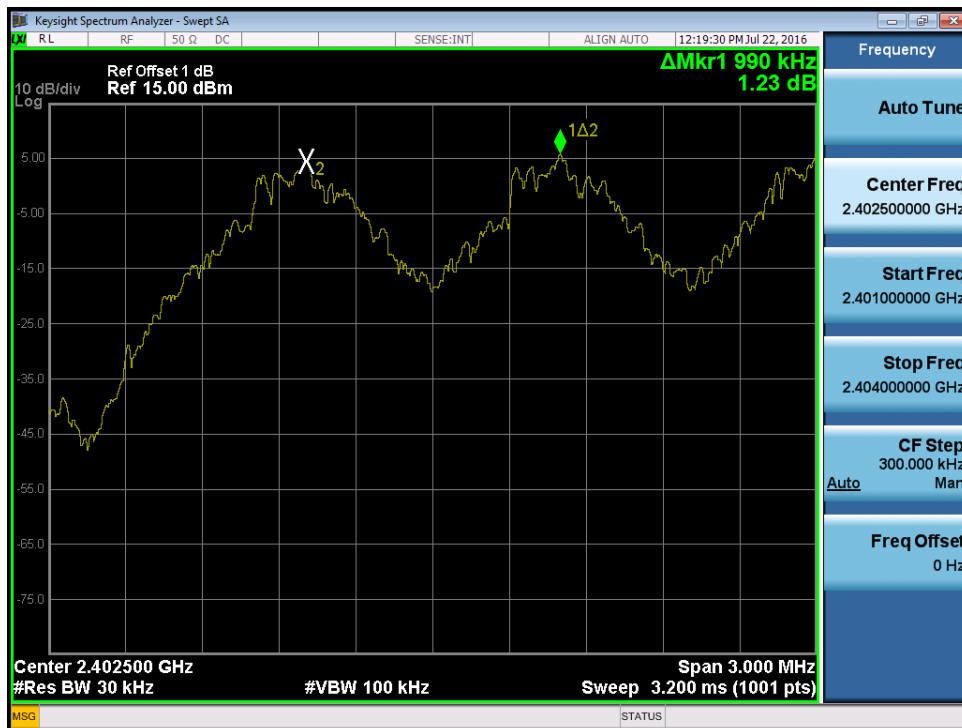

CH39



CH78

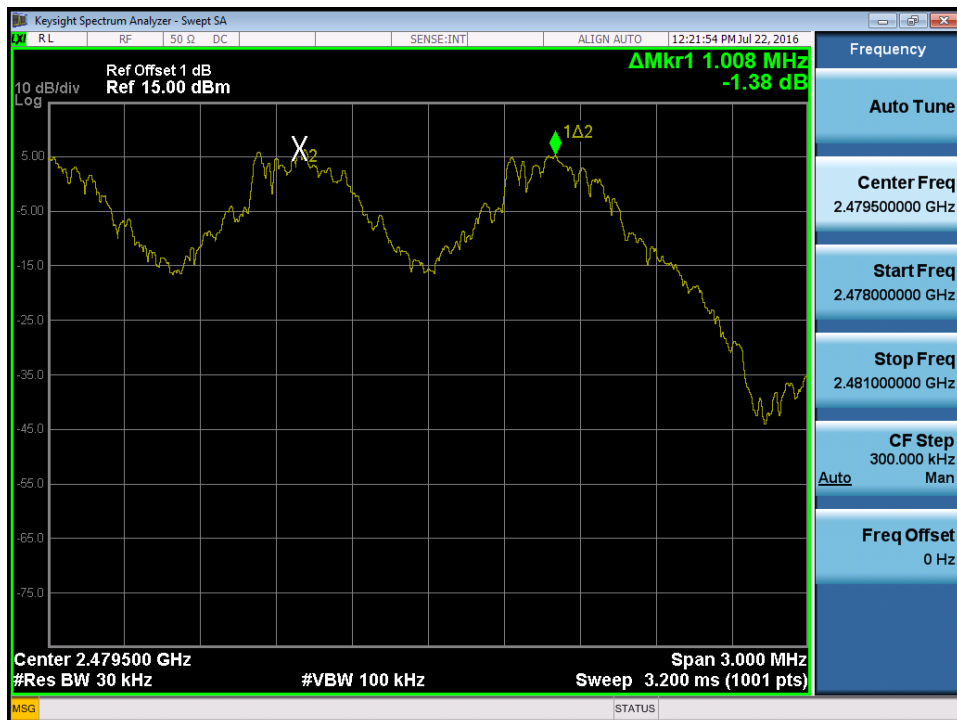

Test Mode : Hopping on \_3Mbps

Frequency (MHz)	Channel Separation (MHz)	2/3 of 20dB Bandwidth (MHz)	Test Result
2402	0.990	0.805	Pass
2441	1.000	0.805	Pass
2480	0.988	0.804	Pass

**CH00**

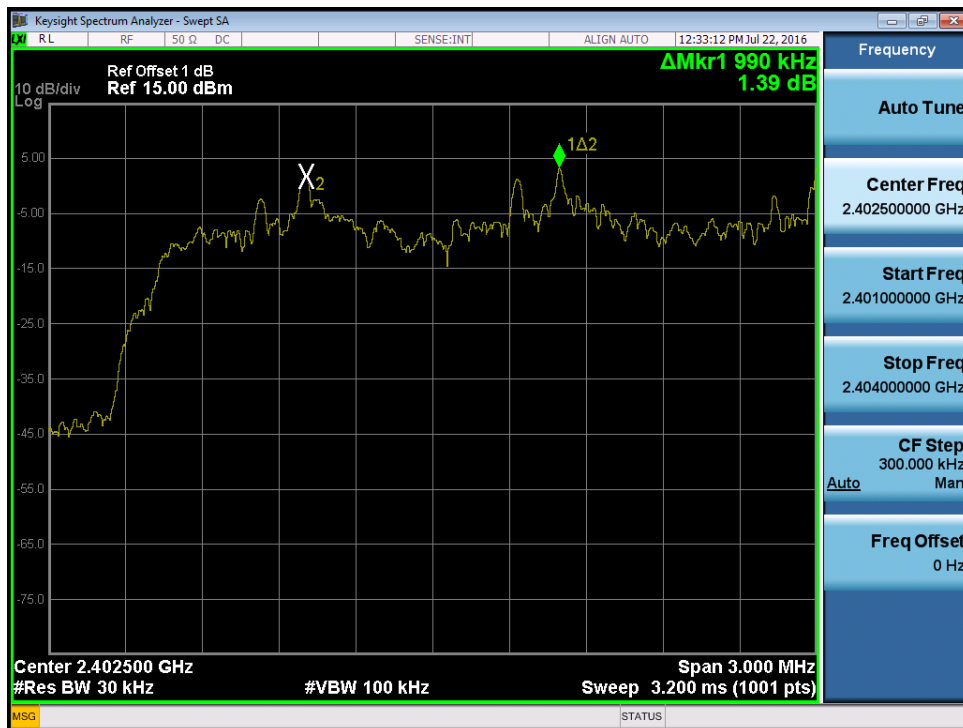

CH39



CH78



## ATTACHMENT H - BANDWIDTH

Test Mode : TX Mode \_1Mbps

Frequency (MHz)	20dB Bandwidth (MHz)	99% Occupied BW (MHz)	Test Result
2402	0.912	0.838	Pass
2441	0.874	0.836	Pass
2480	0.887	0.834	Pass

**CH00**

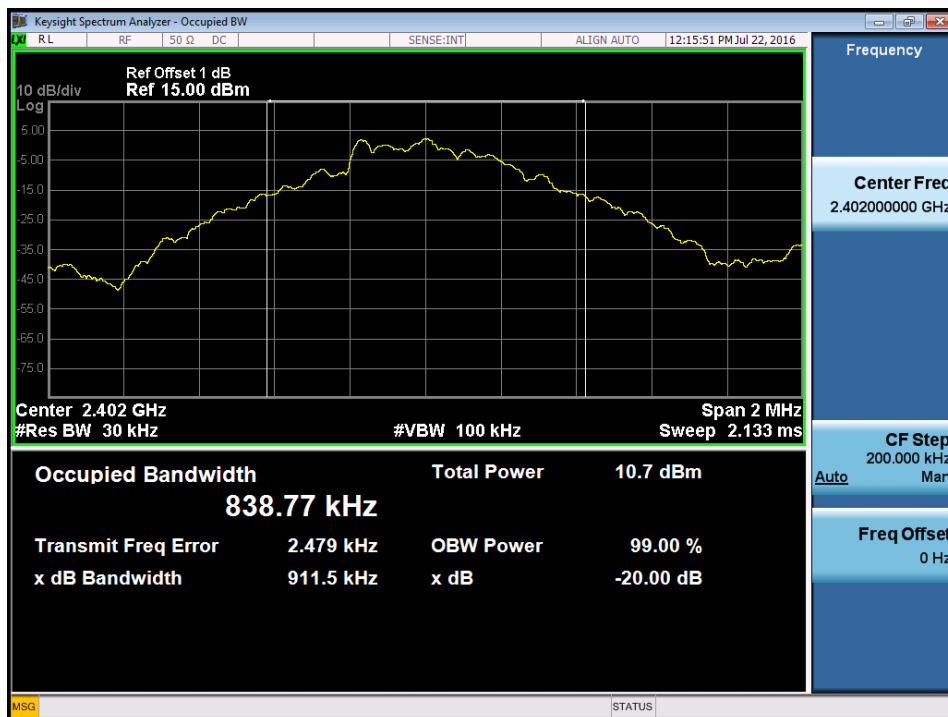

CH39

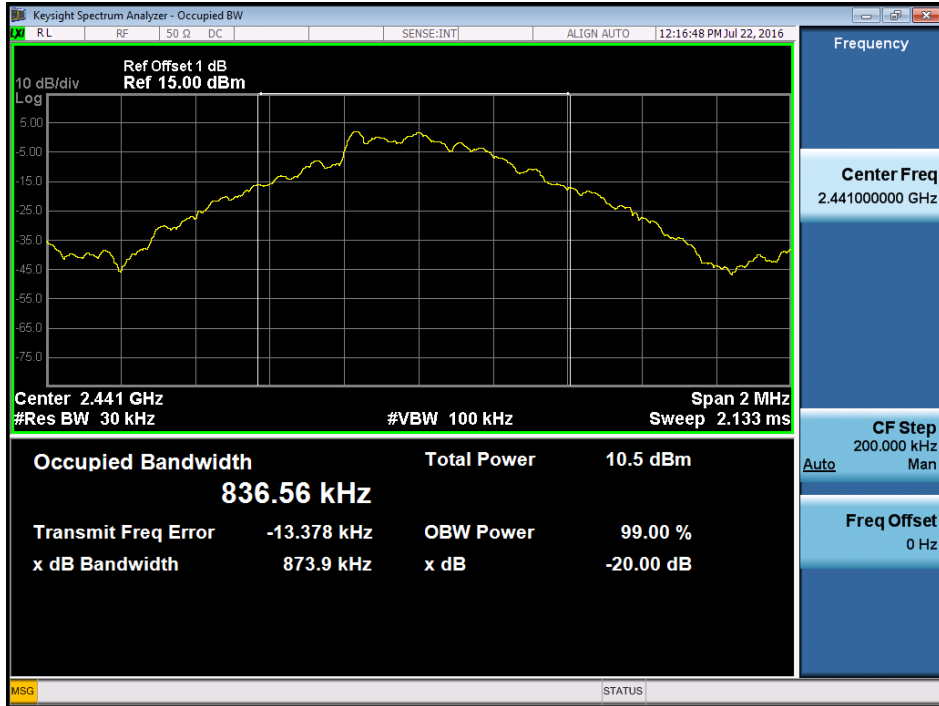

CH78

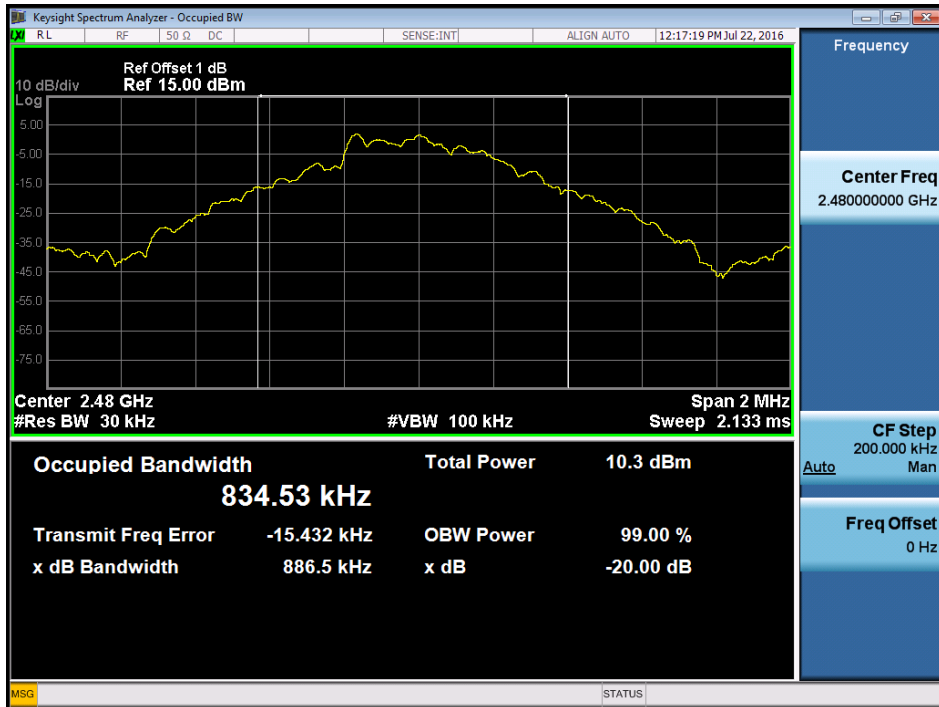

Test Mode : TX Mode \_3Mbps

Frequency (MHz)	20dB Bandwidth (MHz)	99% Occupied BW (MHz)	Test Result
2402	1.208	1.140	Pass
2441	1.208	1.134	Pass
2480	1.207	1.137	Pass

CH00

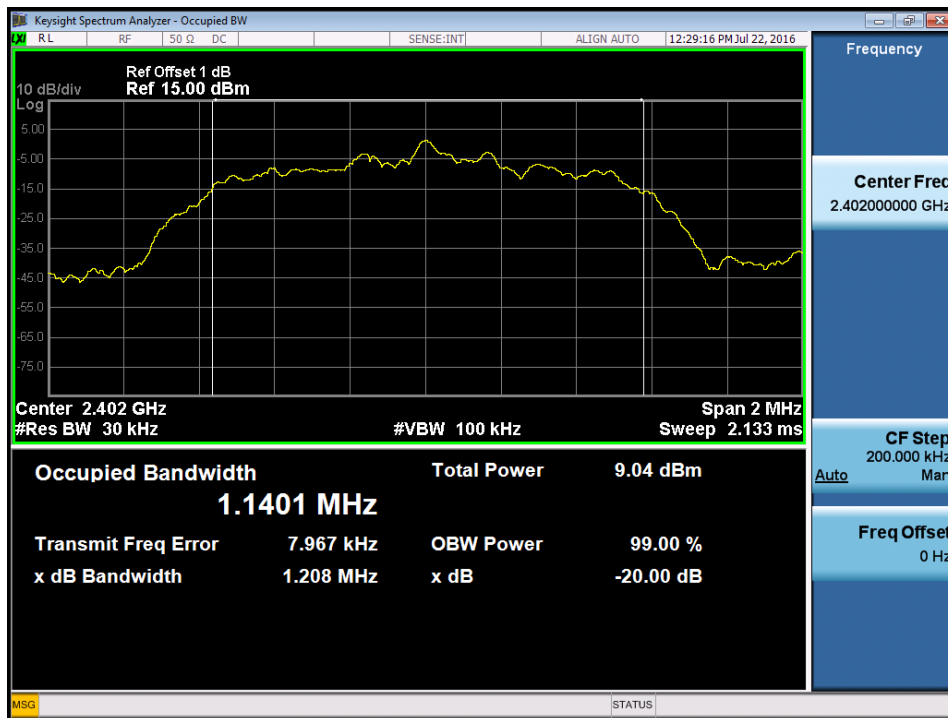

CH39

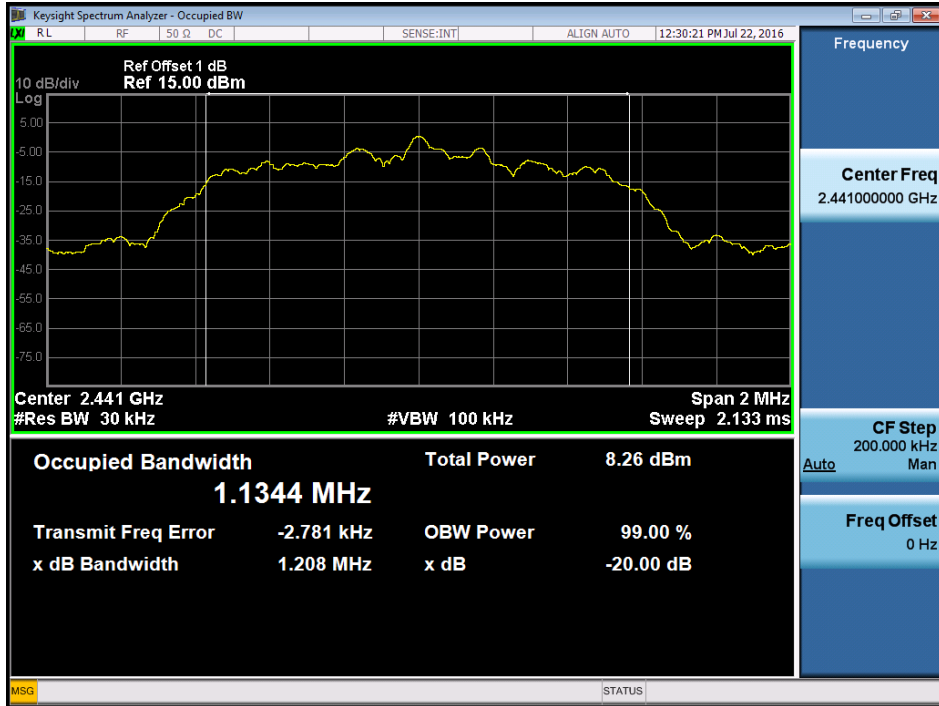

CH78

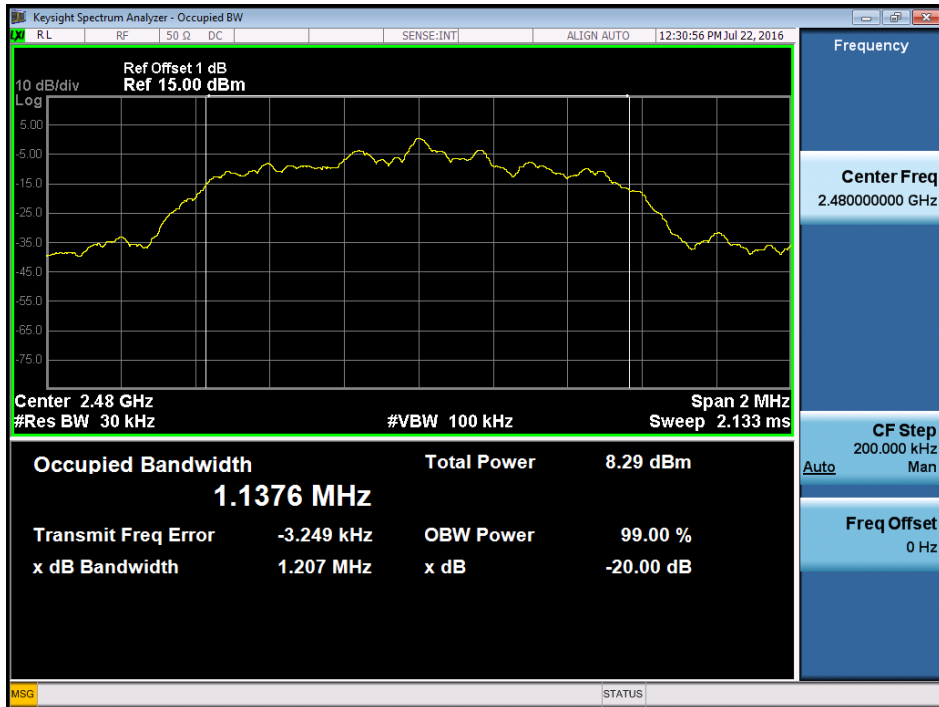

## ATTACHMENT I - PEAK OUTPUT POWER

Test Mode : TX Mode \_1Mbps

Frequency (MHz)	Conducted Power (dBm)	Conducted Power (W)	Max. Limit (dBm)	Max. Limit (W)	Test Result
2402	3.81	0.0024	30.00	1.00	Pass
2441	3.77	0.0024	30.00	1.00	Pass
2480	3.73	0.0024	30.00	1.00	Pass

### CH00

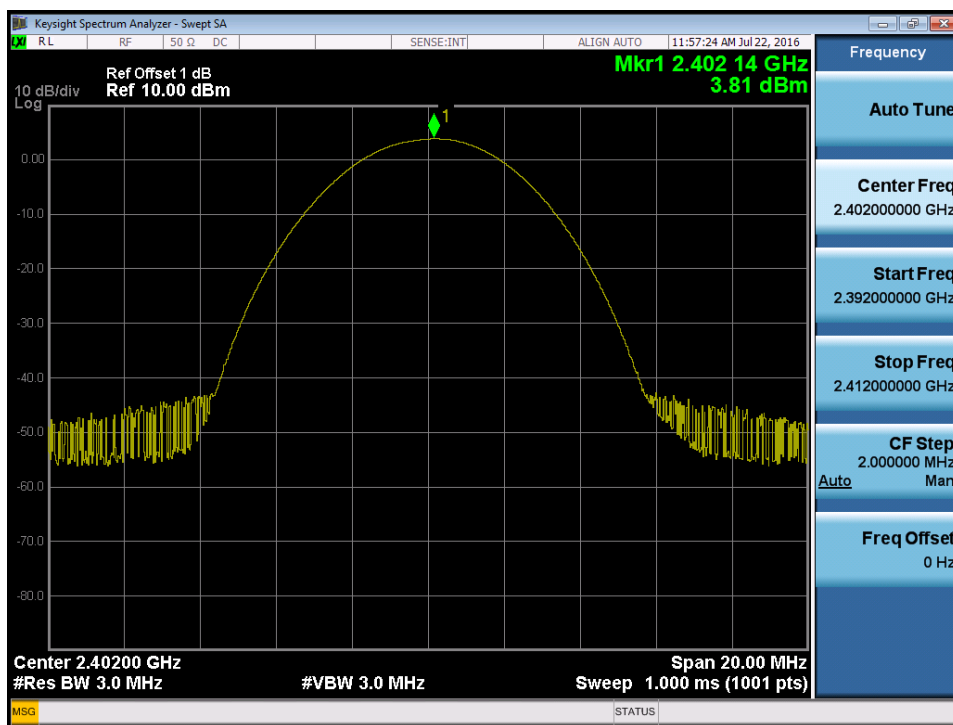

CH39

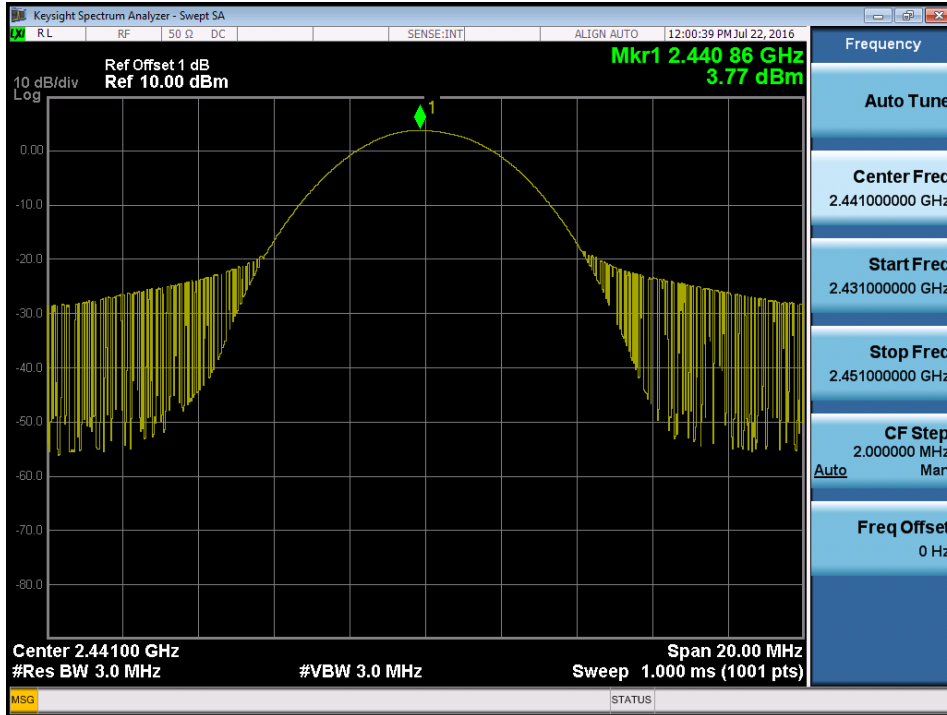

CH78

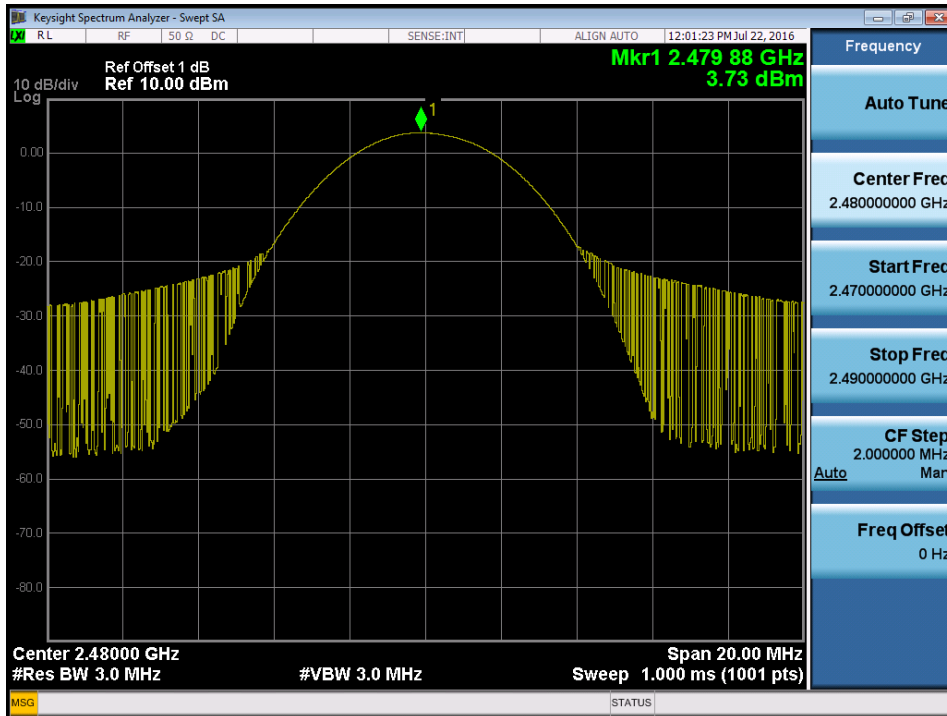

Test Mode : TX Mode \_3Mbps

Frequency (MHz)	Conducted Power (dBm)	Conducted Power (W)	Max. Limit (dBm)	Max. Limit (W)	Test Result
2402	3.65	0.0023	30.00	1.00	Pass
2441	3.89	0.0024	30.00	1.00	Pass
2480	3.77	0.0024	30.00	1.00	Pass

### CH00

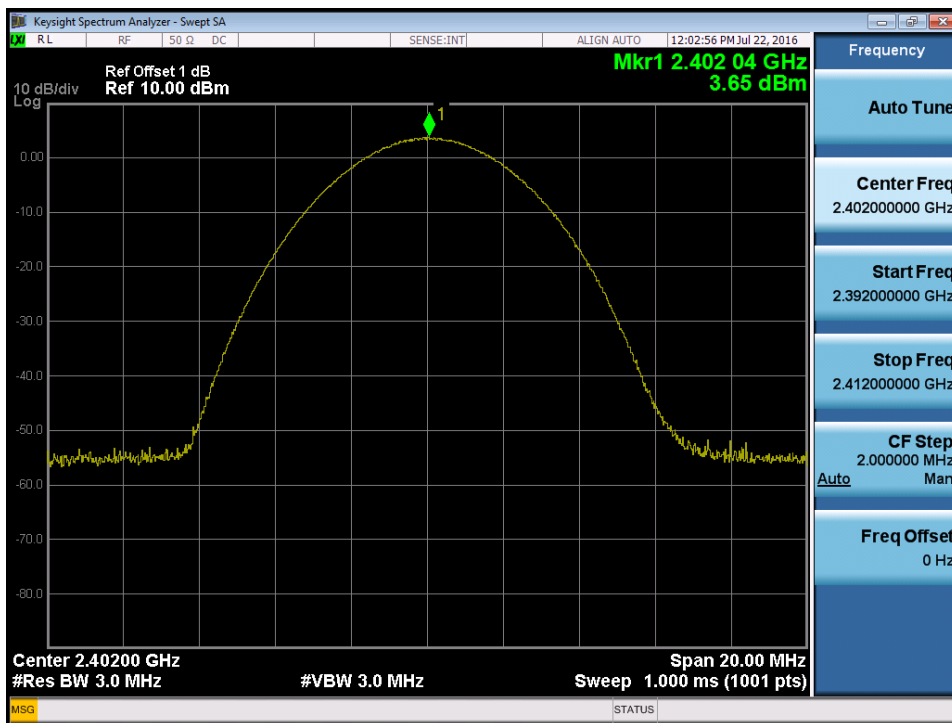

CH39

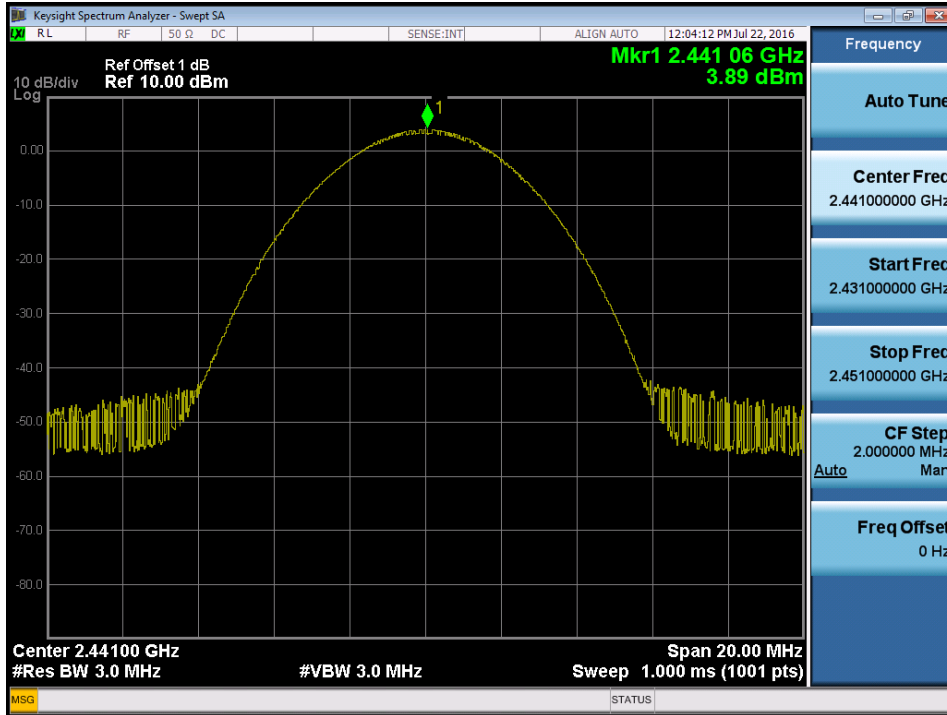

CH78

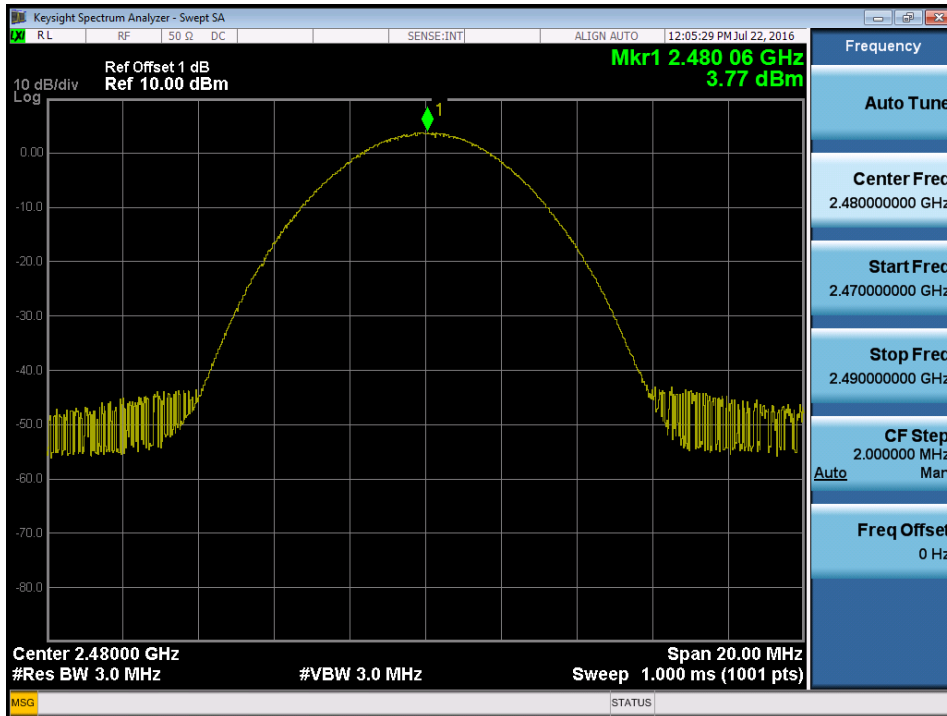

# ATTACHMENT J - ANTENNA CONDUCTED SPURIOUS EMISSION

### CH00 (Lower)\_1Mbps

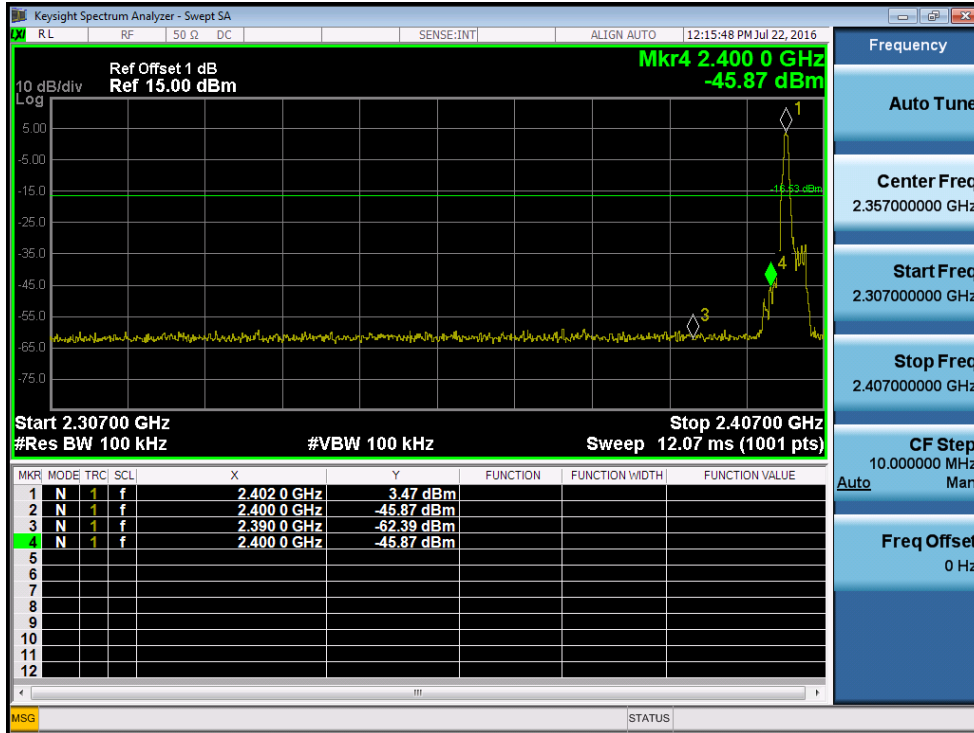

### CH78 (Upper)\_1Mbps

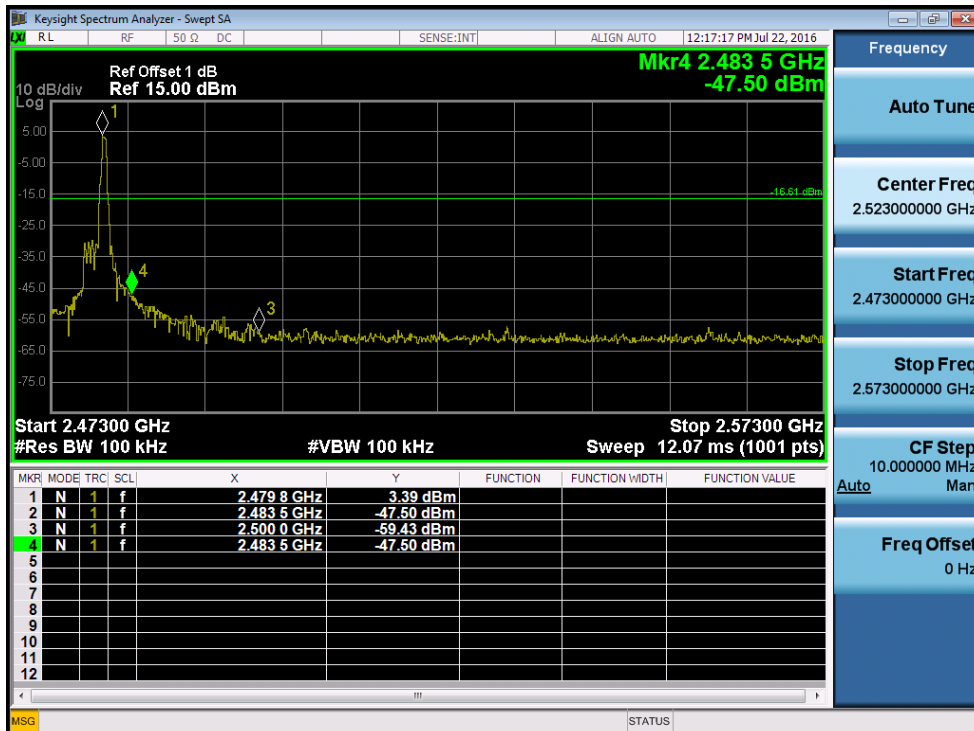

### CH00 Hopping on mode (Lower)\_1Mbps

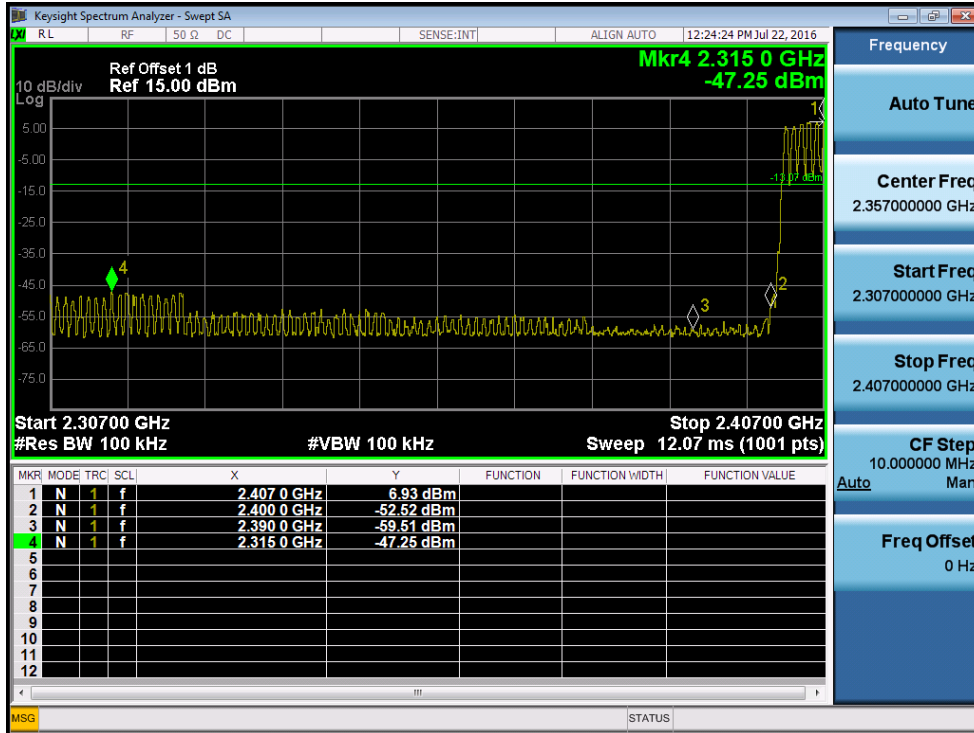

### CH78 Hopping on mode (Upper)\_1Mbps

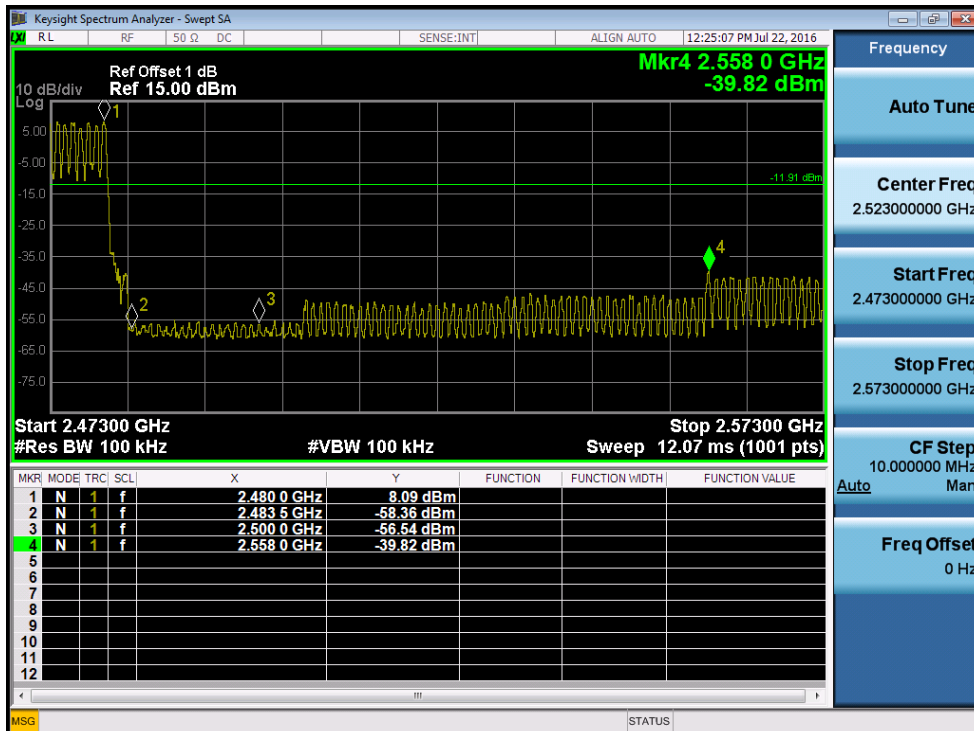

### CH00 (10 Harmonic of the frequency) \_1Mbps

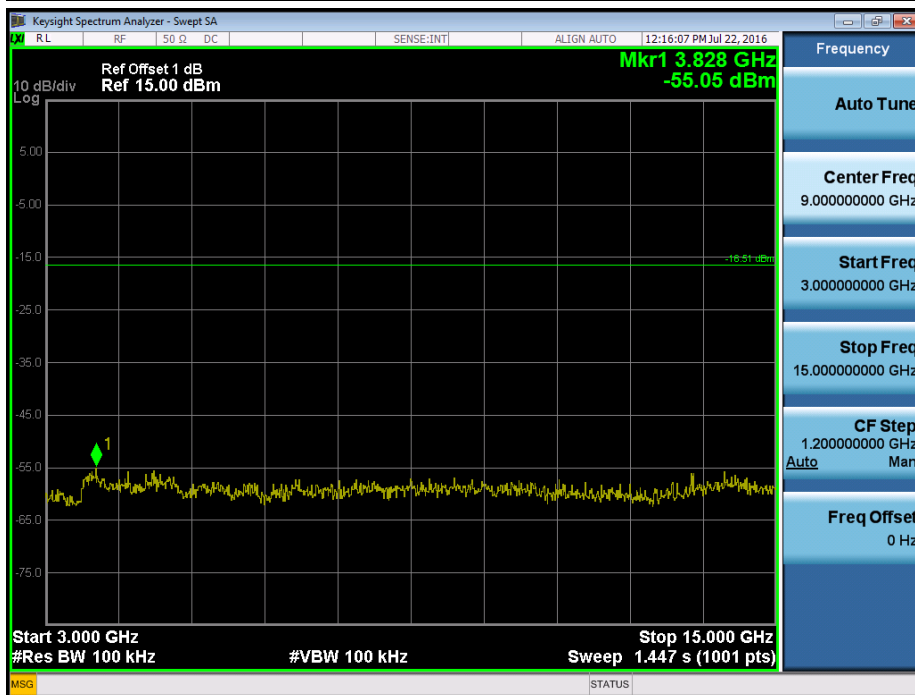
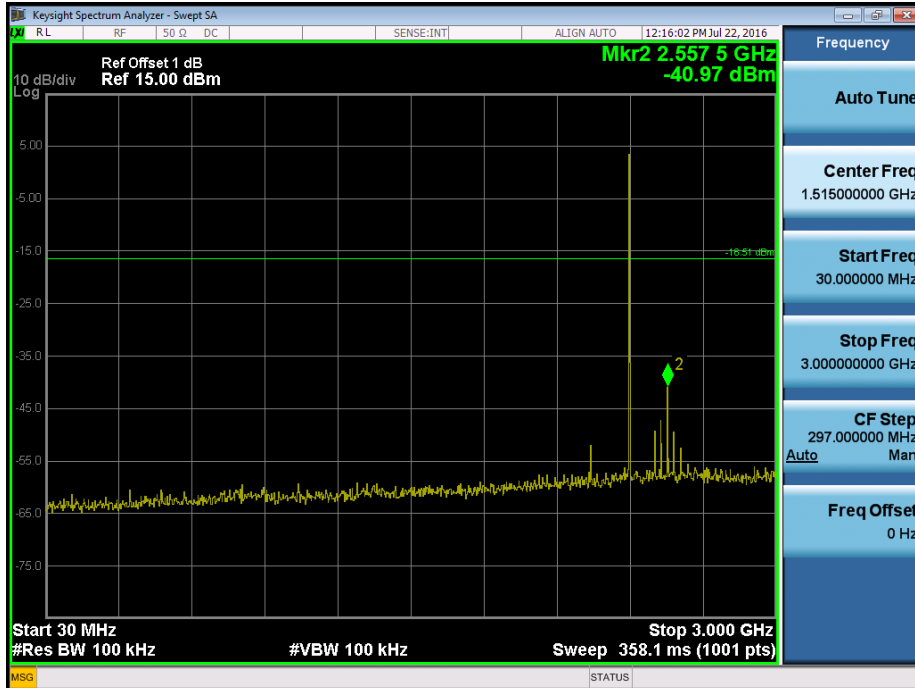

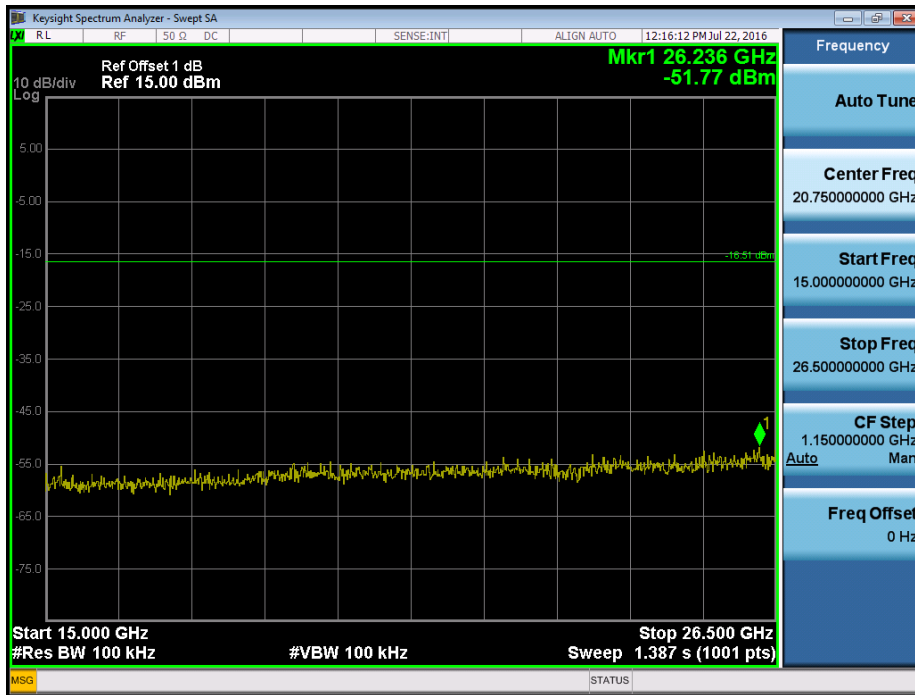

CH39 (10 Harmonic of the frequency) \_1Mbps

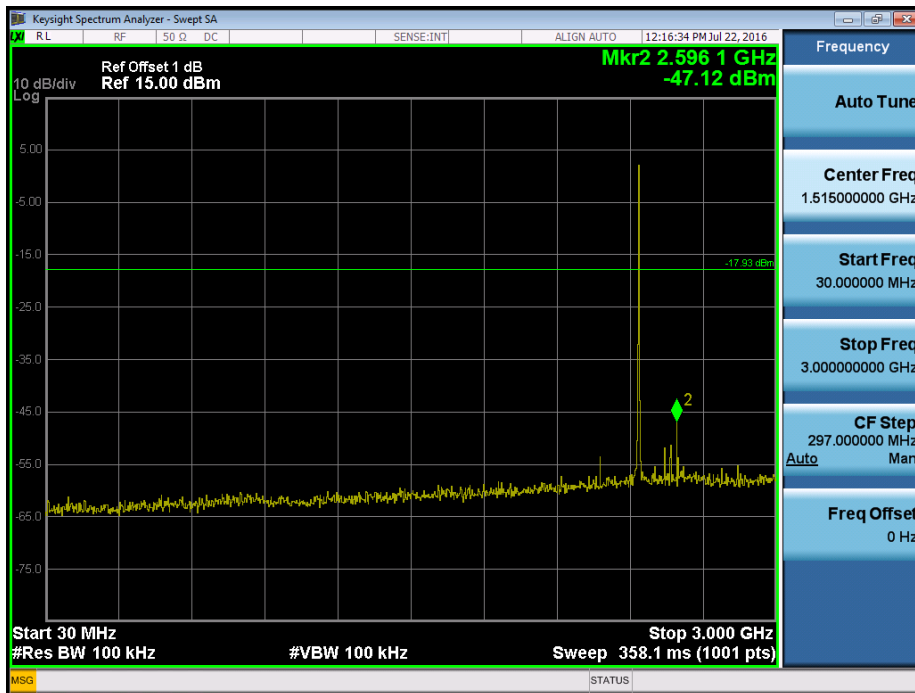

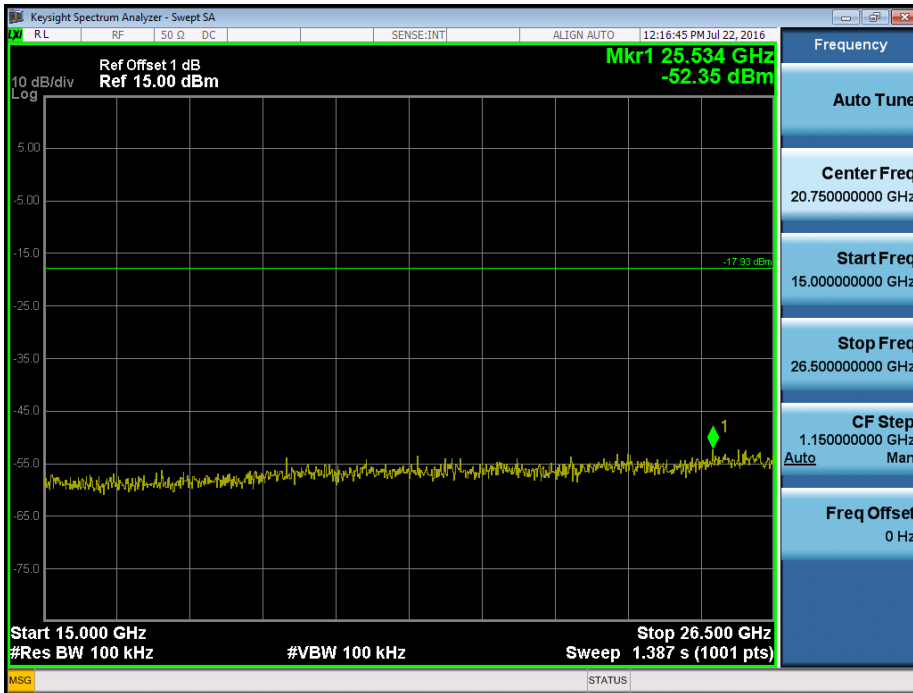
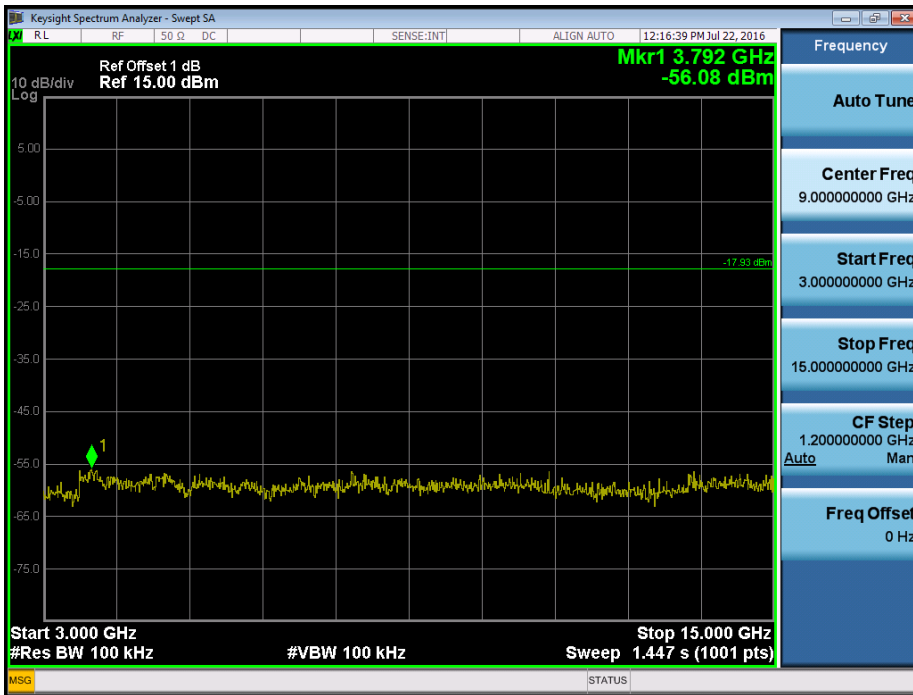

### CH78 (10 Harmonic of the frequency) \_1Mbps

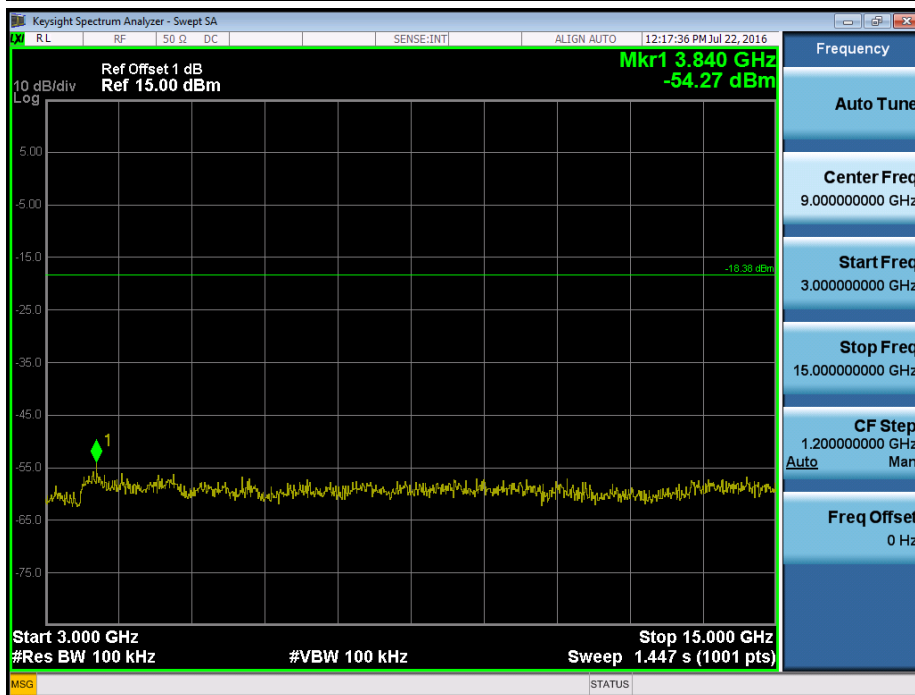
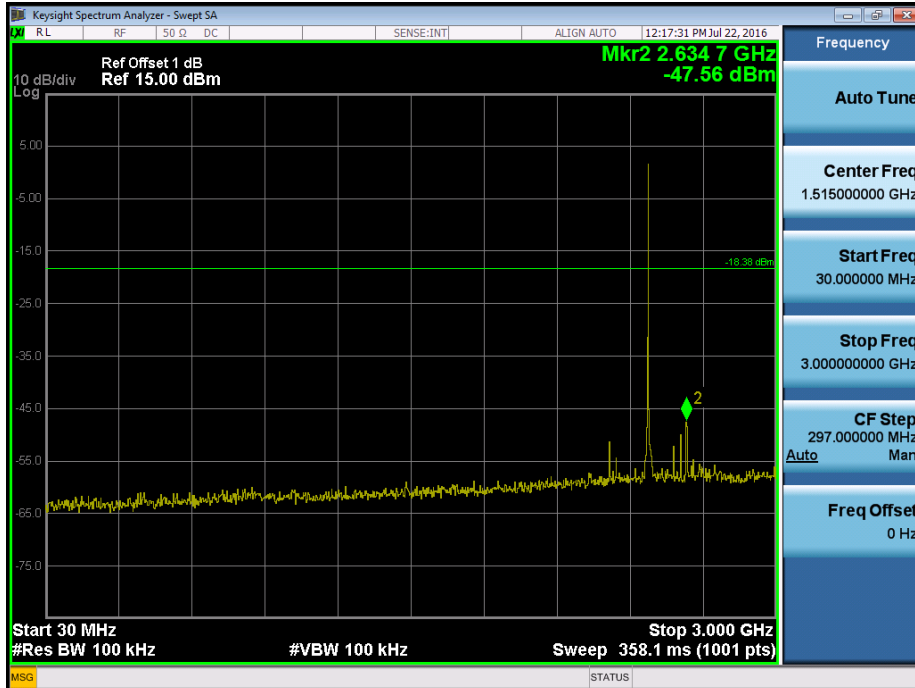

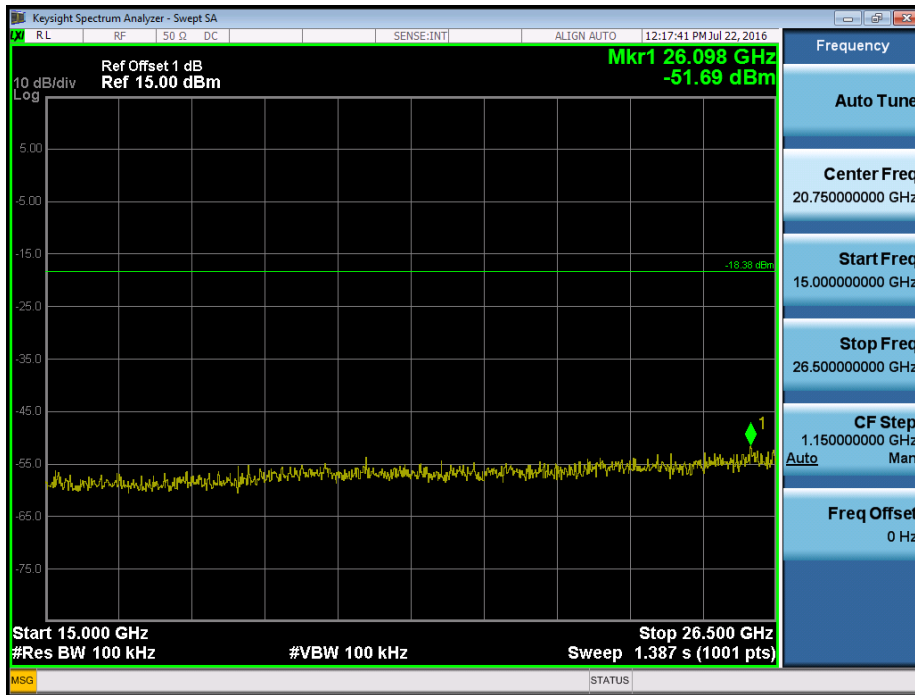

### CH00 (Lower) \_3Mbps

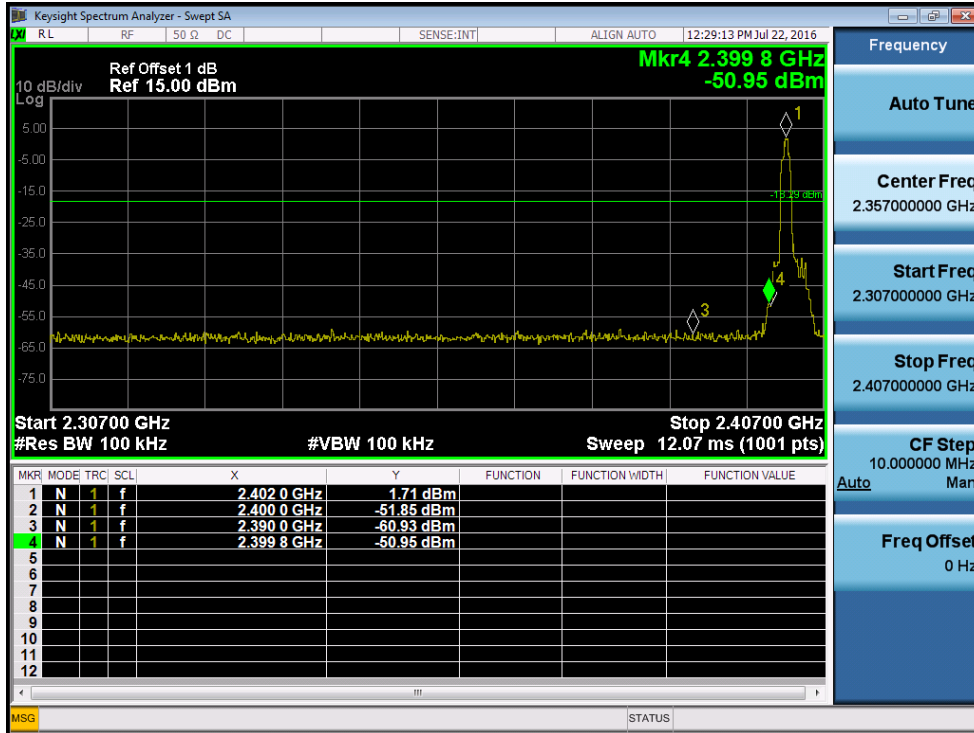

### CH78 (Upper) \_3Mbps

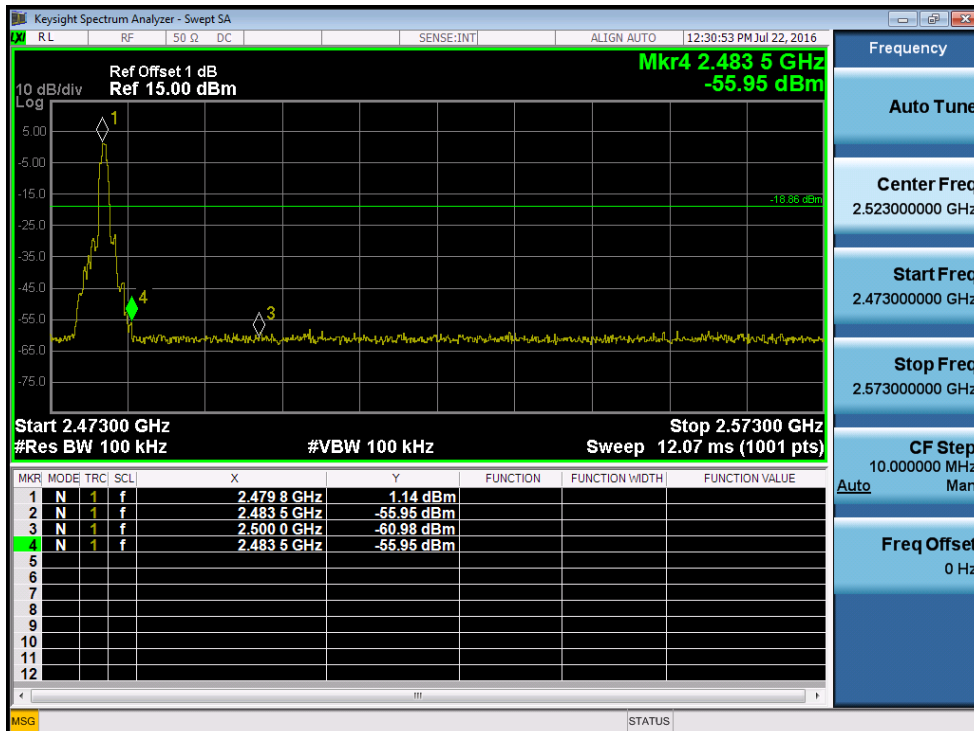

### CH00 Hopping on mode (Lower)\_3Mbps

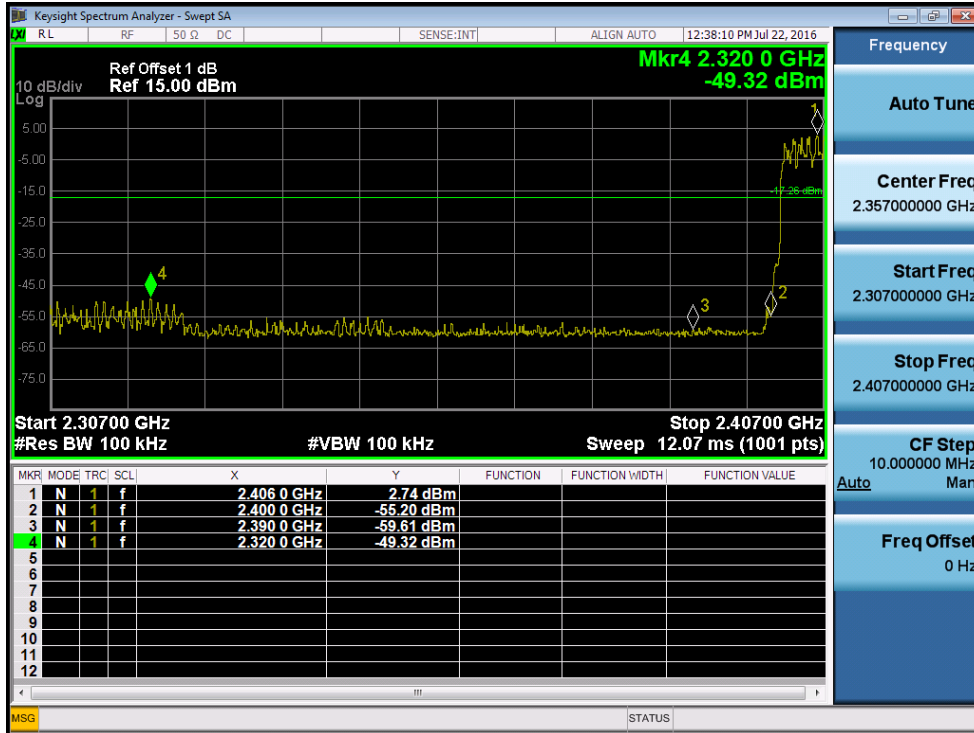

### CH78 Hopping on mode (Upper)\_3Mbps

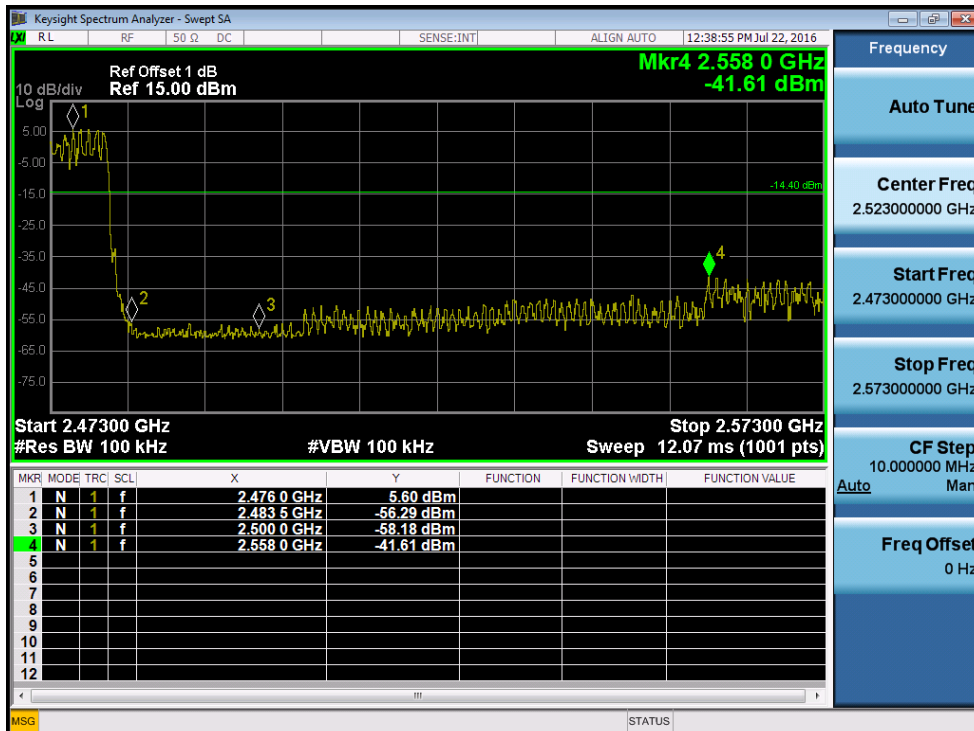

### CH00 (10 Harmonic of the frequency) \_3Mbps

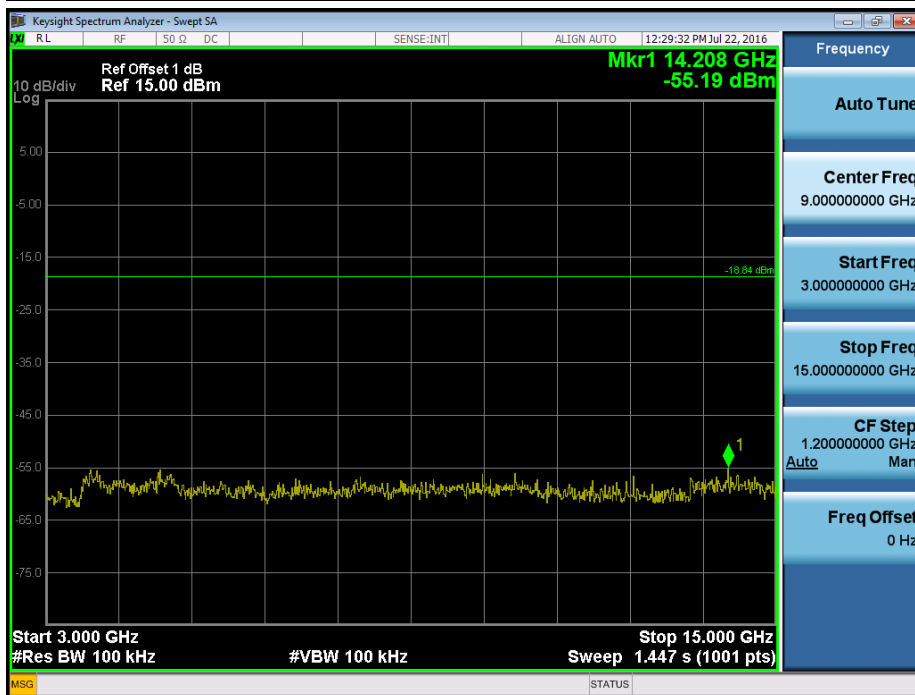
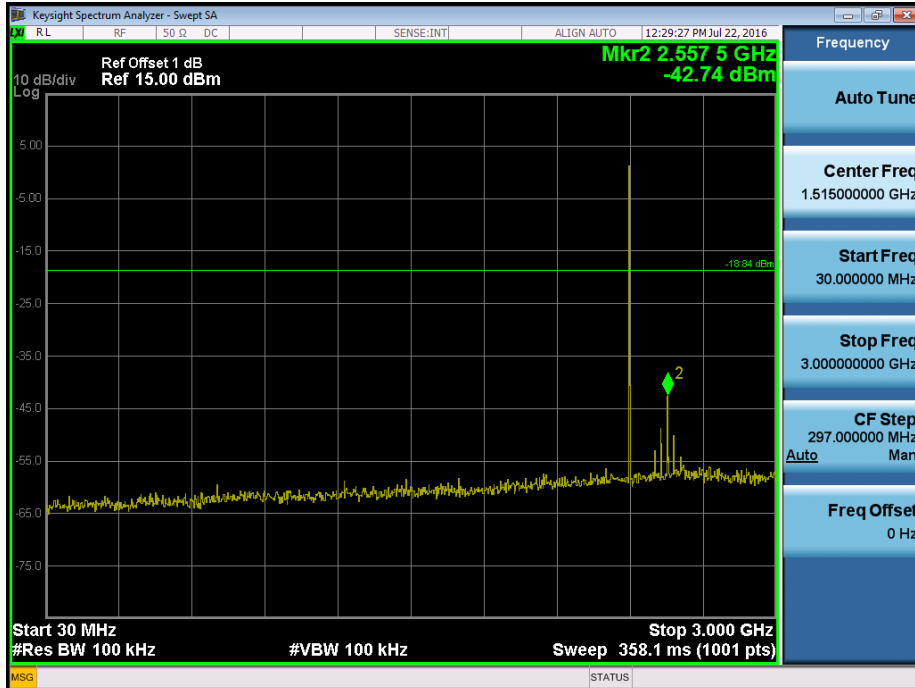

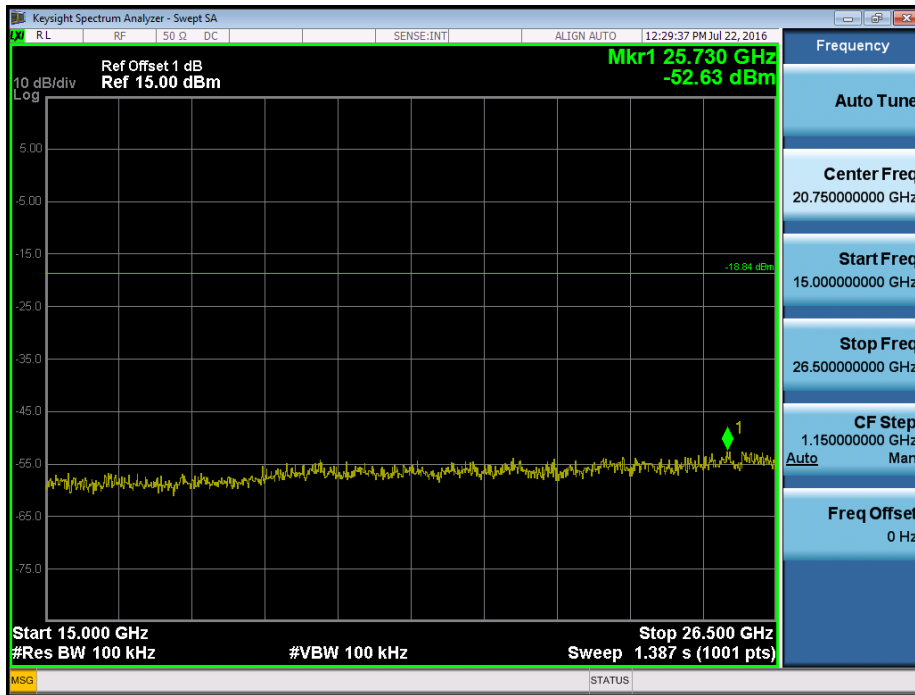

CH39 (10 Harmonic of the frequency) \_3Mbps

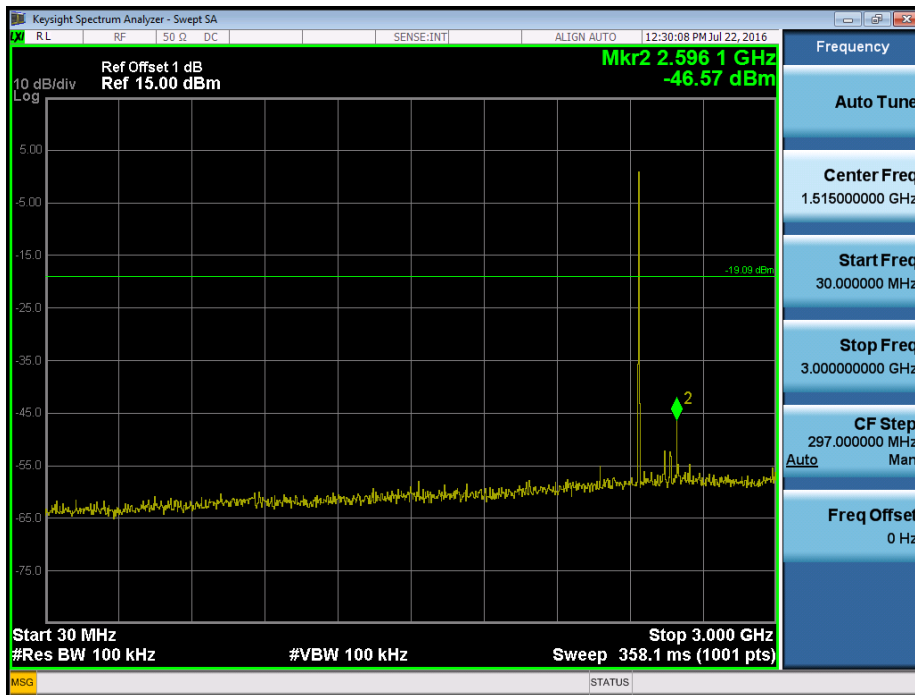

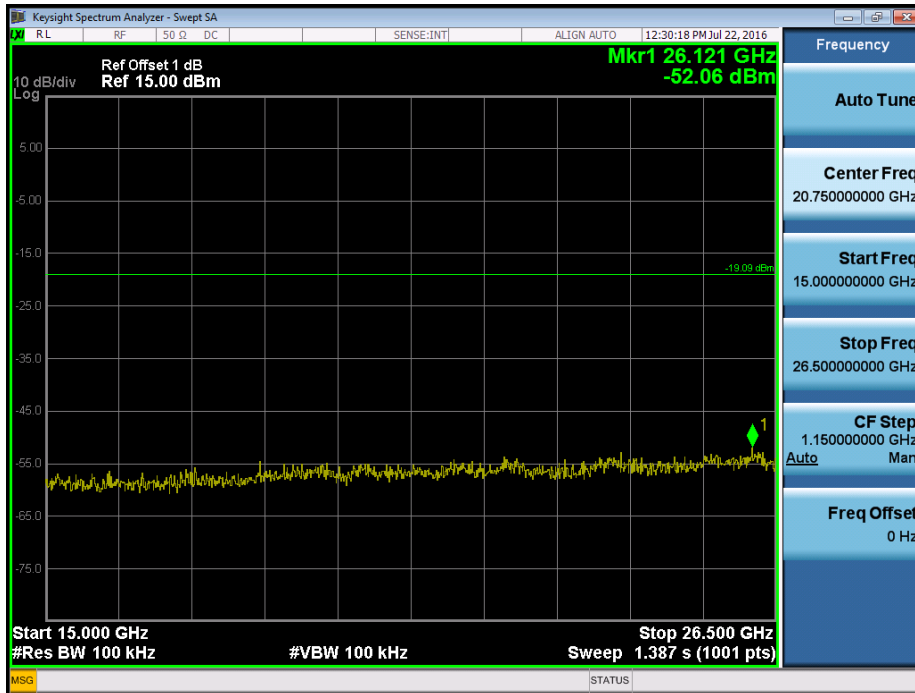
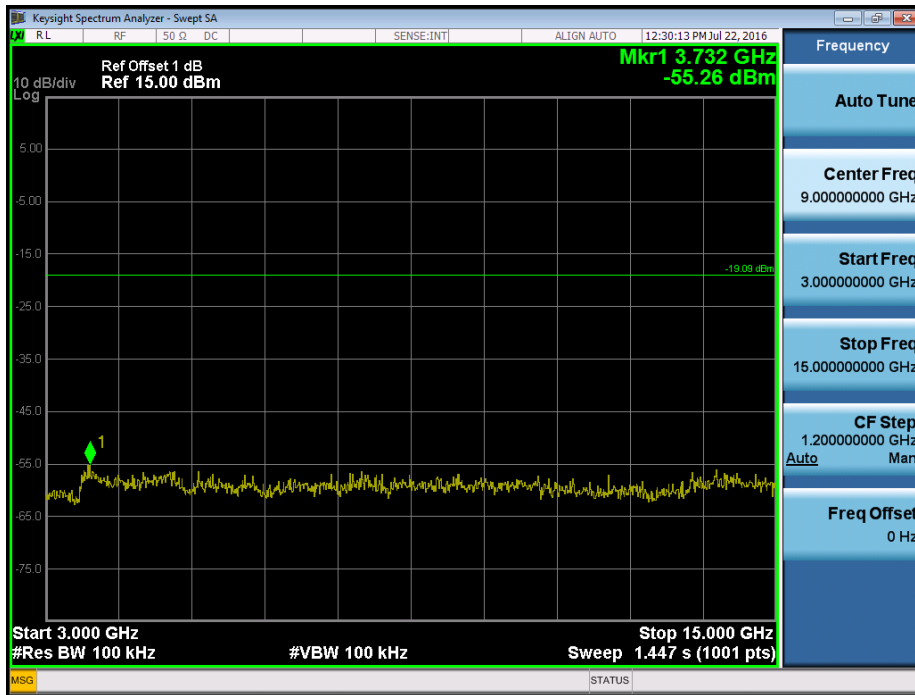

### CH78 (10 Harmonic of the frequency) \_3Mbps

