



BUREAU VERITAS

Test Report No.: RF160712N001-3



# TEST REPORT



Applicant	Harman International Industries, Incorporated
Address	8500 Balboa Blvd, Northridge, CA 91329, UNITED STATES

Manufacturer or Supplier	Harman International Industries, Incorporated
Address	8500 Balboa Blvd, Northridge, CA 91329, UNITED STATES
Product Name	JBL Google Cast Speaker
Brand Name	JBL
Model	JBL PLAYLIST
Additional Model & Model Difference	N/A
Date of tests	Aug. 01, 2016 ~ Sep. 01, 2016

The tests have been carried out according to the requirements of the following standard:

**FCC Part 15, Subpart E, Section 15.407**

**CONCLUSION: The submitted sample was found to COMPLY with the test requirement**

Tested by Breeze Jiang Project Engineer / EMC Department	Approved by Glyn He Supervisor/ EMC Department
	 Date: Sep. 05, 2016

This report is for your exclusive use. Any copying or replication of this report to or for any other person or entity, or use of our name or trademark, is permitted only with our prior written permission. This report sets forth our findings solely with respect to the test samples identified herein. The results set forth in this report are not indicative or representative of the quality or characteristics of the lot from which a test sample was taken or any similar or identical product unless specifically and expressly noted. Our report includes all of the tests requested by you and the results thereof based upon the information that you provided to us. You have 60 days from date of issuance of this report to notify us of any material error or omission caused by our negligence, provided, however, that such notice shall be in writing and shall specifically address the issue you wish to raise. A failure to raise such issue within the prescribed time shall constitute your unqualified acceptance of the completeness of this report, the tests conducted and the correctness of the report contents. Unless specific mention, the uncertainty of measurement has been explicitly taken into account to declare the compliance or non-compliance to the specification

Bureau Veritas Shenzhen Co., Ltd.  
Dongguan Branch

No. 34, Chenwulu Section, Guantai Rd., Houjie  
Town, Dongguan City,  
Guangdong 523942, China

Tel: +86 769 8593 5656  
Fax: +86 769 8593 1080  
Email: [customerservice.dg@cn.bureauveritas.com](mailto:customerservice.dg@cn.bureauveritas.com)



## TABLE OF CONTENTS

<b>RELEASE CONTROL RECORD .....</b>	<b>4</b>
<b>1. SUMMARY OF TEST RESULTS.....</b>	<b>5</b>
1.1 MEASUREMENT UNCERTAINTY .....	5
<b>2. GENERAL INFORMATION .....</b>	<b>6</b>
2.1 GENERAL DESCRIPTION OF EUT.....	6
2.2 DESCRIPTION OF TEST MODES.....	7
2.2.1 TEST MODE APPLICABILITY AND TESTED CHANNEL DETAIL .....	10
2.3 DUTY CYCLE OF TEST SIGNAL .....	12
2.4 DESCRIPTION OF SUPPORT UNITS.....	13
2.5 GENERAL DESCRIPTION OF APPLIED STANDARDS.....	13
<b>3. TEST TYPES AND RESULTS.....</b>	<b>14</b>
3.1 RADIATED EMISSION AND BANDEDGE MEASUREMENT .....	14
3.1.1 LIMITS OF RADIATED EMISSION AND BANDEDGE MEASUREMENT .....	14
3.1.2 LIMITS OF UNWANTED EMISSION OUT OF THE RESTRICTED BANDS .....	15
3.1.3 TEST INSTRUMENTS.....	16
3.1.4 TEST PROCEDURES .....	17
3.1.5 DEVIATION FROM TEST STANDARD .....	17
3.1.6 TEST SETUP .....	18
3.1.7 EUT OPERATING CONDITION .....	18
3.1.8 TEST RESULTS .....	19
3.2 CONDUCTED EMISSION MEASUREMENT .....	58
3.2.1 LIMITS OF CONDUCTED EMISSION MEASUREMENT .....	58
3.2.2 TEST INSTRUMENTS.....	58
3.2.3 TEST PROCEDURES .....	59
3.2.4 DEVIATION FROM TEST STANDARD .....	59
3.2.5 TEST SETUP .....	59
3.2.6 EUT OPERATING CONDITIONS .....	59
3.2.7 TEST RESULTS .....	60
3.3 TRANSMIT POWER MEASUREMENT .....	62



3.3.1	LIMITS OF TRANSMIT POWER MEASUREMENT .....	62
3.3.2	TEST SETUP .....	62
3.3.3	TEST INSTRUMENTS.....	63
3.3.4	TEST PROCEDURE .....	63
3.3.5	DEVIATION FROM TEST STANDARD .....	64
3.3.6	EUT OPERATING CONDITIONS .....	64
3.3.7	TEST RESULTS .....	65
3.4	PEAK POWER SPECTRAL DENSITY MEASUREMENT.....	75
3.4.1	LIMITS OF PEAK POWER SPECTRAL DENSITY MEASUREMENT .....	75
3.4.2	TEST SETUP .....	75
3.4.3	TEST INSTRUMENTS.....	75
3.4.4	TEST PROCEDURES .....	75
3.4.5	DEVIATION FROM TEST STANDARD .....	76
3.4.6	EUT OPERATING CONDITIONS .....	76
3.4.7	TEST RESULTS .....	77
3.5	FREQUENCY STABILITY .....	84
3.5.1	LIMITS OF FREQUENCY STABILITY MEASUREMENT .....	84
3.5.2	TEST SETUP .....	84
3.5.3	TEST INSTRUMENTS.....	84
3.5.4	TEST PROCEDURE .....	85
3.5.5	DEVIATION FROM TEST STANDARD .....	85
3.5.6	EUT OPERATING CONDITION .....	85
3.5.7	TEST RESULTS .....	86
<b>4.</b>	<b>PHOTOGRAPHS OF THE TEST CONFIGURATION .....</b>	<b>87</b>
<b>5.</b>	<b>APPENDIX A – MODIFICATIONS RECORDERS FOR ENGINEERING CHANGES TO THE EUT BY THE LAB .....</b>	<b>88</b>



**BUREAU**  
**VERITAS**

Test Report No.: RF160712N001-3

## RELEASE CONTROL RECORD

ISSUE NO.	REASON FOR CHANGE	DATE ISSUED
RF160712N001-3	Original release.	Sep. 05, 2016



# 1. SUMMARY OF TEST RESULTS

The EUT has been tested according to the following specifications:

APPLIED STANDARD: FCC PART 15, SUBPART E (SECTION 15.407 UNDER NEW RULE)			
STANDARD SECTION	TEST TYPE	RESULT	REMARK
15.407(b)(6)	AC Power Conducted Emissions	PASS	Meet the requirement of limit.
15.407(b) (1/2/3/4/6)	Radiated Emissions & Band Edge Measurement	PASS	Meet the requirement of limit.
15.407(a)(1/2/3)	Max Average Transmit Power	PASS	Meet the requirement of limit.
15.407(a)(1/2/3)	Peak Power Spectral Density	PASS	Meet the requirement of limit.
15.407(g)	Frequency Stability	PASS	Meet the requirement of limit.
15.203	Antenna Requirement	PASS	No antenna connector is used

## 1.1 MEASUREMENT UNCERTAINTY

Where relevant, the following measurement uncertainty levels have been estimated for tests performed on the EUT as specified in CISPR 16-4-2:

MEASUREMENT	FREQUENCY	UNCERTAINTY
Conducted emissions	9kHz~30MHz	2.70dB
Radiated emissions	9KHz ~ 30MHz	2.90dB
	30MHz ~ 1GMHz	3.83dB
	1GHz ~ 18GHz	4.93dB
	18GHz ~ 40GHz	4.80dB

This uncertainty represents an expanded uncertainty expressed at approximately the 95% confidence level using a coverage factor of k = 2.



## 2. GENERAL INFORMATION

### 2.1 GENERAL DESCRIPTION OF EUT

<b>PRODUCT NAME</b>	JBL Google Cast Speaker
<b>MODEL NO.</b>	JBL PLAYLIST
<b>FCC ID</b>	APIJBLPLAYLIST
<b>POWER SUPPLY</b>	AC 120V 60Hz
<b>MODULATION TYPE</b>	254QAM, 64QAM, 16QAM, QPSK, BPSK
<b>MODULATION TECHNOLOGY</b>	OFDM
<b>TRANSFER RATE</b>	802.11a: 54.0/ 48.0/ 36.0/ 24.0/ 18.0/ 12.0/ 9.0/ 6.0Mbps 802.11n: up to 300.0Mbps 802.11ac 80: up to 433.3Mbps
<b>OPERATING FREQUENCY</b>	5180 ~ 5240MHz, 5260 ~ 5320MHz 5500 ~ 5700MHz, 5745 ~ 5825MHz
<b>NUMBER OF CHANNEL</b>	5180 ~ 5240MHz: 4 for 802.11a, 802.11n (20MHz) 2 for 802.11n (40MHz), 1 for 802.11ac 80MHz 5260 ~ 5320MHz: 4 for 802.11a, 802.11n (20MHz) 2 for 802.11n (40MHz), 1 for 802.11ac 80MHz 5500 ~ 5700MHz: 11 for 802.11a, 802.11n (20MHz) 5 for 802.11n (40MHz), 2 for 802.11ac 80MHz 5745 ~ 5825MHz: 5 for 802.11a, 802.11n (20MHz) 2 for 802.11n (40MHz), 1 for 802.11ac 80MHz
<b>CONDUCTED OUTPUT POWER</b>	18.86 dBm for 5180 ~ 5240MHz (Maximum AVG Power) 18.86 dBm for 5260 ~ 5320MHz (Maximum AVG Power) 19.14 dBm for 5500 ~ 5700MHz (Maximum AVG Power) 18.93 dBm for 5745 ~ 5825MHz (Maximum AVG Power)
<b>ANTENNA TYPE</b>	5180 ~ 5240MHz: FPCB antenna with 3.22dBi gain 5260 ~ 5320MHz: FPCB antenna with 3.57dBi gain 5500 ~ 5700MHz: FPCB antenna with 3.85dBi gain 5745 ~ 5825MHz: FPCB antenna with 3.32dBi gain
<b>I/O PORTS</b>	Refer to user's manual
<b>CABLE SUPPLIED</b>	AC Line: Unshielded, Detachable, 1.50m



**NOTE:**

1. The EUT incorporates a SIMO function. Physically, the EUT provides 1 completed transmitter and 1 receiver.

<b>MODULATION MODE</b>	<b>TX FUNCTION</b>
<b>802.11a</b>	1TX/1RX
<b>802.11n (20MHz)</b>	1TX/1RX
<b>802.11n (40MHz)</b>	1TX/1RX
<b>802.11ac (80MHz)</b>	1TX/1RX

2. For a more detailed features description, please refer to the manufacturer's specifications or the user's manual.
3. For the test results, the EUT had been tested with all conditions. But only the worst case was shown in test report.
4. Please refer to the EUT photo document (Reference No.: 160712N001) for detailed product photo.



## 2.2 DESCRIPTION OF TEST MODES

### FOR 5150 ~ 5250MHz

3 channels are provided for 802.11a, 802.11n (20MHz):

CHANNEL	FREQUENCY	CHANNEL	FREQUENCY
36	5180 MHz	40	5200 MHz
48	5240 MHz		

2 channels are provided for 802.11n (40MHz):

CHANNEL	FREQUENCY	CHANNEL	FREQUENCY
38	5190 MHz	46	5230 MHz

1 channel is provided for 802.11ac (80MHz):

CHANNEL	FREQUENCY	CHANNEL	FREQUENCY
42	5210MHz		

### FOR 5250 ~ 5350MHz

3 channels are provided for 802.11a, 802.11n (20MHz):

CHANNEL	FREQUENCY	CHANNEL	FREQUENCY
52	5260 MHz	60	5300 MHz
64	5320 MHz		

2 channels are provided for 802.11n (40MHz):

CHANNEL	FREQUENCY	CHANNEL	FREQUENCY
54	5270 MHz	62	5310 MHz

1 channel is provided for 802.11ac (80MHz):

CHANNEL	FREQUENCY	CHANNEL	FREQUENCY
58	5290MHz		



**FOR 5470 ~ 5725MHz**

3 channels are provided for 802.11a, 802.11n (20MHz):

CHANNEL	FREQUENCY	CHANNEL	FREQUENCY
100	5500 MHz	116	5580 MHz
140	5700 MHz		

3 channels are provided for 802.11n (40MHz):

CHANNEL	FREQUENCY	CHANNEL	FREQUENCY
102	5510 MHz	110	5550 MHz
134	5670 MHz		

1 channel is provided for 802.11ac (80MHz):

CHANNEL	FREQUENCY	CHANNEL	FREQUENCY
106	5530MHz		

**FOR 5725 ~ 5850MHz**

3 channels are provided for 802.11a, 802.11n (20MHz):

CHANNEL	FREQUENCY	CHANNEL	FREQUENCY
149	5745MHz	157	5785MHz
165	5825MHz	--	--

2 channels are provided for 802.11n (40MHz):

CHANNEL	FREQUENCY	CHANNEL	FREQUENCY
151	5755MHz	159	5795MHz

1 channel is provided for 802.11ac (80MHz):

CHANNEL	FREQUENCY	CHANNEL	FREQUENCY
155	5775MHz		



2.2.1 TEST MODE APPLICABILITY AND TESTED CHANNEL DETAIL

EUT CONFIGURE MODE	APPLICABLE TO				DESCRIPTION
	RE≥1G	RE<1G	PLC	APCM	
-	√	√	√	√	Powered by AC 120V with wifi(5G) link

Where **RE≥1G**: Radiated Emission above 1GHz      **RE<1G**: Radiated Emission below 1GHz  
**PLC**: Power Line Conducted Emission      **APCM**: Antenna Port Conducted Measurement

NOTE:

1. The EUT had been pre-tested on the positioned of each 3 axis. The worst case was found when positioned on **Z-plane**.

NOTE: "-" means no effect.

**RADIATED EMISSION TEST (ABOVE 1GHz):**

- Pre-Scan has been conducted to determine the worst-case mode from all possible combinations between available modulations, data rates and antenna ports (if EUT with antenna diversity architecture).
- Following channel(s) was (were) selected for the final test as listed below.

EUT CONFIGURE MODE	MODE	FREQ. BAND (MHz)	AVAILABLE CHANNEL	TESTED CHANNEL	MODULATION TECHNOLOGY	MODULATION TYPE	DATA RATE (Mbps)
-	802.11a	5180-5240	36 to 48	36, 40, 48	OFDM	BPSK	6.0
-	802.11n (20MHz)		36 to 48	36, 40, 48	OFDM	BPSK	6.5
-	802.11n (40MHz)		38 to 46	38, 46	OFDM	BPSK	13.5
-	802.11ac 80MHz		42	42	OFDM	BPSK	V0
-	802.11a	5260-5320	52 to 64	52, 60, 64	OFDM	BPSK	6.0
-	802.11n (20MHz)		52 to 64	52, 60, 64	OFDM	BPSK	MCS0
-	802.11n (40MHz)		54 to 62	54, 62	OFDM	BPSK	MCS0
-	802.11ac 80MHz		58	58	OFDM	BPSK	V0
-	802.11a	5500-5700	100 to 140	100, 116, 140	OFDM	BPSK	6.0
-	802.11n (20MHz)		100 to 140	100, 116, 140	OFDM	BPSK	MCS0
-	802.11n (40MHz)		102 to 134	102, 118, 134	OFDM	BPSK	MCS0
-	802.11ac 80MHz		106	106	OFDM	BPSK	V0
-	802.11a	5725-5825	149 to 165	149, 157, 165	OFDM	BPSK	6.0
-	802.11n (20MHz)		149 to 165	149, 157, 165	OFDM	BPSK	MCS0
-	802.11n (40MHz)		151 to 159	151, 159	OFDM	BPSK	MCS0
-	802.11ac 80MHz		155	155	OFDM	BPSK	V0

**RADIATED EMISSION TEST (BELOW 1GHz):**

- Pre-Scan has been conducted to determine the worst-case mode from all possible combinations between available modulations, data rates and antenna ports (if EUT with antenna diversity architecture).
- Following channel(s) was (were) selected for the final test as listed below.

EUT CONFIGURE MODE	MODE	FREQ. BAND (MHz)	AVAILABLE CHANNEL	TESTED CHANNEL	MODULATION TECHNOLOGY	MODULATION TYPE	DATA RATE (Mbps)
-	802.11a	5180-5240 5725-5850	36 to 48 149 to 165	36	OFDM	BPSK	6.0



**POWER LINE CONDUCTED EMISSION TEST:**

- Pre-Scan has been conducted to determine the worst-case mode from all possible combinations between available modulations, data rates and antenna ports (if EUT with antenna diversity architecture).
- Following channel(s) was (were) selected for the final test as listed below.

EUT CONFIGURE MODE	MODE	FREQ. BAND (MHz)	AVAILABLE CHANNEL	TESTED CHANNEL	MODULATION TECHNOLOGY	MODULATION TYPE	DATA RATE (Mbps)
-	802.11a	5180-5240 5725-5850	36 to 48 149 to 165	36	OFDM	BPSK	6.0

**ANTENNA PORT CONDUCTED MEASUREMENT:**

- This item includes all test value of each mode, but only includes spectrum plot of worst value of each mode.
- Pre-Scan has been conducted to determine the worst-case mode from all possible combinations between available modulations, data rates and antenna ports (if EUT with antenna diversity architecture).
- Following channel(s) was (were) selected for the final test as listed below.

EUT CONFIGURE MODE	MODE	FREQ. BAND (MHz)	AVAILABLE CHANNEL	TESTED CHANNEL	MODULATION TECHNOLOGY	MODULATION TYPE	DATA RATE (Mbps)
-	802.11a	5180-5240	36 to 48	36, 40, 48	OFDM	BPSK	6.0
-	802.11n (20MHz)		36 to 48	36, 40, 48	OFDM	BPSK	6.5
-	802.11n (40MHz)		38 to 46	38, 46	OFDM	BPSK	13.5
-	802.11ac 80MHz		42	42	OFDM	BPSK	V0
-	802.11a	5260-5320	52 to 64	52, 60, 64	OFDM	BPSK	6.0
-	802.11n (20MHz)		52 to 64	52, 60, 64	OFDM	BPSK	MCS0
-	802.11n (40MHz)		54 to 62	54, 62	OFDM	BPSK	MCS0
-	802.11ac 80MHz		58	58	OFDM	BPSK	V0
-	802.11a	5500-5700	100 to 140	100, 116, 140	OFDM	BPSK	6.0
-	802.11n (20MHz)		100 to 140	100, 116, 140	OFDM	BPSK	MCS0
-	802.11n (40MHz)		102 to 134	102, 110, 134	OFDM	BPSK	MCS0
-	802.11ac 80MHz		106	106	OFDM	BPSK	V0
-	802.11a	5725-5825	149 to 165	149, 157, 165	OFDM	BPSK	6.0
-	802.11n (20MHz)		149 to 165	149, 157, 165	OFDM	BPSK	MCS0
-	802.11n (40MHz)		151 to 159	151, 159	OFDM	BPSK	MCS0
-	802.11ac 80MHz		155	155	OFDM	BPSK	V0

**TEST CONDITION:**

APPLICABLE TO	ENVIRONMENTAL CONDITIONS	INPUT POWER	TESTED BY
RE<1G	25deg. C, 51%RH	AC 120V 60Hz	Eric Fang
RE≥1G	25deg. C, 51%RH	AC 120V 60Hz	Eric Fang
PLC	20deg. C, 56%RH	AC 120V 60Hz	Breeze Jiang
APCM	20deg. C, 55%RH	AC 120V 60Hz	Breeze Jiang



### 2.3 DUTY CYCLE OF TEST SIGNAL

**802.11a:** Duty cycle = 1.432/1.453 = 0.99, Duty factor =  $10 * \log(1/0.99) = 0.044$

**802.11n (20MHz):** Duty cycle = 1.34/1.362 = 0.98, Duty factor =  $10 * \log(1/0.98) = 0.088$

**802.11n (40MHz):** Duty cycle = 0.663/0.685 = 0.97, Duty factor =  $10 * \log(1/0.97) = 0.13$

**802.11ac (80MHz):** Duty cycle = 0.331/0.353 = 0.94, Duty factor =  $10 * \log(1/0.94) = 0.27$

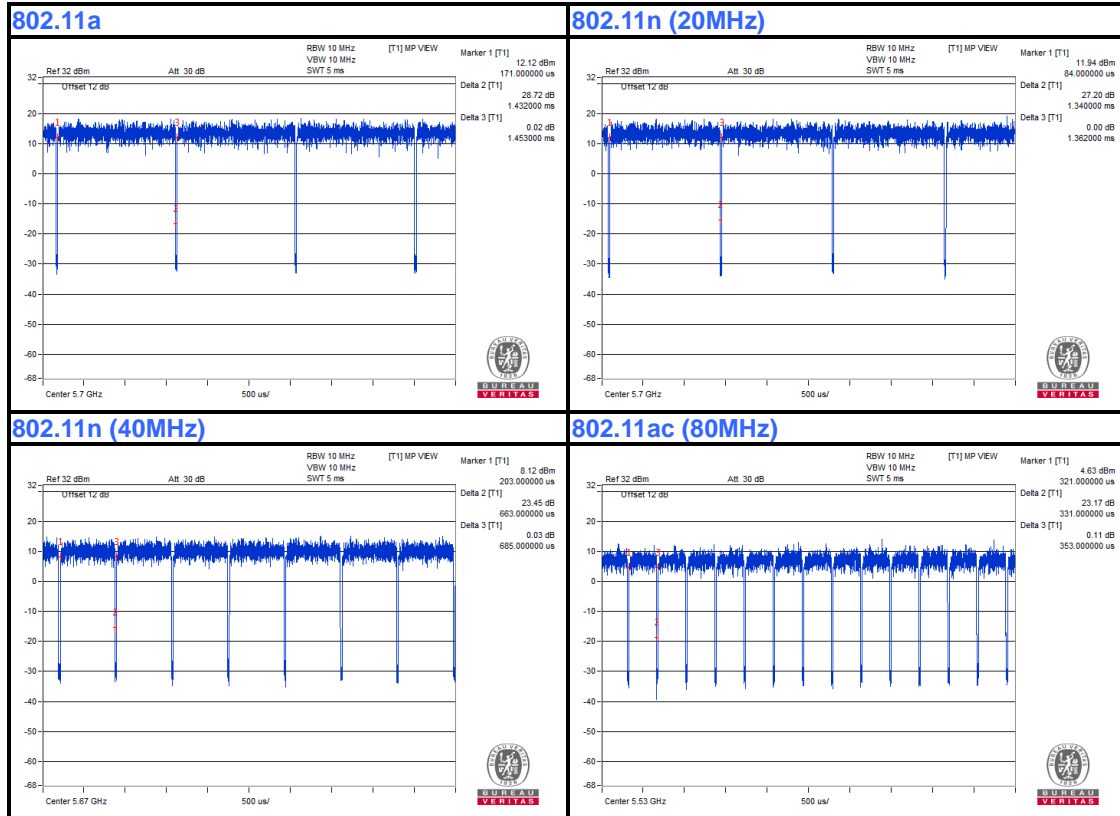



## 2.4 DESCRIPTION OF SUPPORT UNITS

The EUT has been tested as an independent unit together with other necessary accessories or support units. The following support units or accessories were used to form a representative test configuration during the tests.

NO.	PRODUCT	BRAND	MODEL NO.	SERIAL NO.	FCC ID
1	N/A	N/A	N/A	N/A	N/A

NO.	DESCRIPTION OF THE ABOVE SUPPORT UNITS
1	N/A

## 2.5 GENERAL DESCRIPTION OF APPLIED STANDARDS

The EUT is a RF Product. According to the specification of the EUT declared by the manufacturer, it must comply with the requirements of the following standards:

**FCC Part 15, Subpart E (15.407)**

**789033 D02 General UNII Test Procedures New Rules v01r03**

**ANSI C63.10-2013**

All test items have been performed and recorded as per the above standards.



### 3. TEST TYPES AND RESULTS

#### 3.1 RADIATED EMISSION AND BANDEDGE MEASUREMENT

##### 3.1.1 LIMITS OF RADIATED EMISSION AND BANDEDGE MEASUREMENT

Radiated emissions which fall in the restricted bands must comply with the radiated emission limits specified as below table:

FREQUENCIES (MHz)	FIELD STRENGTH (microvolts/meter)	MEASUREMENT DISTANCE (meters)
0.009 ~ 0.490	2400/F(kHz)	300
0.490 ~ 1.705	24000/F(kHz)	30
1.705 ~ 30.0	30	30
30 ~ 88	100	3
88 ~ 216	150	3
216 ~ 960	200	3
Above 960	500	3

**NOTE:**

1. The lower limit shall apply at the transition frequencies.
2. Emission level (dBuV/m) = 20 log Emission level (uV/m).
3. For frequencies above 1000MHz, the field strength limits are based on average detector, however, the peak field strength of any emission shall not exceed the maximum permitted average limits, specified above by more than 30dB under any condition of modulation.



**3.1.2 LIMITS OF UNWANTED EMISSION OUT OF THE RESTRICTED BANDS**

APPLICABLE TO	LIMIT	
789033 D02 General UNII Test Procedures New Rules v01r03	FIELD STRENGTH AT 3m	
	PK: 74 (dBµV/m)	AV: 54 (dBµV/m)
APPLICABLE TO	EIRP LIMIT	EQUIVALENT FIELD STRENGTH AT 3m
15.407(b)(1)	PK: -27 (dBm/MHz)	PK: 68.2 (dBµV/m)
15.407(b)(2)		
15.407(b)(3)		
15.407(b)(4)	Note	Note

**NOTE:** For transmitters operating in the 5.725-5.85 GHz band:

15.407(b)(4)(i) All emissions shall be limited to a level of -27 dBm/MHz at 75 MHz or more above or below the band edge increasing linearly to 10 dBm/MHz at 25 MHz above or below the band edge, and from 25 MHz above or below the band edge increasing linearly to a level of 15.6 dBm/MHz at 5 MHz above or below the band edge, and from 5 MHz above or below the band edge increasing linearly to a level of 27 dBm/MHz at the band edge.

The following formula is used to convert the equipment isotropic radiated power (eirp) to field strength:

$$E = \frac{1000000\sqrt{30P}}{3} \mu\text{V/m, where P is the eirp (Watts).}$$

**3.1.3 TEST INSTRUMENTS**

<b>Equipment</b>	<b>Manufacturer</b>	<b>Model No.</b>	<b>Serial No.</b>	<b>Last Cal.</b>	<b>Next Cal.</b>
EMI Test Receiver	Rohde&Schwarz	ESR7	101494	Apr. 05,16	Apr. 04,17
Signal and Spectrum Analyzer	Rohde&Schwarz	FSV7	102331	Nov. 09,15	Nov. 08,16
Bilog Antenna	Teseq	CBL 6111D	30643	Jul. 14, 16	Jul. 13, 17
Horn Antenna (1GHz -18GHz)	ETS -Lindgren	3117	00062558	May 18,16	May 17,17
GPS Generator+ Antenna	TOJOIN	GNSS-5000A	E1-010119	Aug. 08, 16	Aug. 07, 17
3m Semi-anechoic Chamber	ETS-LINDGREN	9m*6m*6m	NSEMC003	Mar. 12,16	Mar. 11,18
Test Software	ADT	ADT_Radiated_V7.6.15.9.2	N/A	N/A	N/A
Horn Antenna	SCHWARZBECK	BBHA 9170	BBHA9170242	Mar. 12,16	Mar. 11,17
Amplifier (9kHz-1GHz)	SONOMA	310D	186955	Mar. 04,16	Mar. 03, 17
Pre-Amplifier(1-18G)	HP	8449B	3008A00409	Apr. 25,16	Apr. 24,17
Pre-Amplifier (18GHz-40GHz)	EMCI	EMC 184045	980102	Nov. 20,15	Nov. 19,16
Test Software	ADT	ADT_Radiated_V7.6.15.9.2	N/A	N/A	N/A
BLUETOOTH TESTER	Rohde&Schwarz	CBT32	100811	Aug. 08,16	Aug. 07,17

**NOTE:**

1. The test was performed in 966 Chamber.
2. The calibration interval of the above test instruments is 12 months and the calibrations are traceable to CEPREI/CHINA, GRGT/CHINA and NIM/CHINA.
3. The FCC Site Registration No. is 494399.



### 3.1.4 TEST PROCEDURES

- a. The EUT was placed on the top of a rotating table 1.5 meters above the ground at a 3 meter semi-anechoic chamber. The table was rotated 360 degrees to determine the position of the highest radiation.
- b. The EUT was set 3 meters away from the interference-receiving antenna, which was mounted on the top of a variable-height antenna tower.
- c. The antenna is a broadband antenna, and its height is varied from one meter to four meters above the ground to determine the maximum value of the field strength. Both horizontal and vertical polarizations of the antenna are set to make the measurement.
- d. For each suspected emission, the EUT was arranged to its worst case and then the antenna was tuned to heights from 1 meter to 4 meters and the rotatable table was turned from 0 degrees to 360 degrees to find the maximum reading.
- e. The test-receiver system was set to Peak Detect Function and Specified Bandwidth with Maximum Hold Mode.
- f. If the emission level of the EUT in peak mode was 10dB lower than the limit specified, then testing could be stopped and the peak values of the EUT would be reported. Otherwise the emissions that did not have 10dB margin would be re-tested one by one using peak, quasi-peak or average method as specified and then reported in a data sheet.

**NOTE:**

1. The resolution bandwidth and video bandwidth of test receiver/spectrum analyzer is 120kHz for Quasi-peak detection at frequency below 1GHz.
2. The resolution bandwidth of test receiver/spectrum analyzer is 1MHz and video bandwidth is 3MHz for Peak detection at frequency above 1GHz.
3. The resolution bandwidth of test receiver/spectrum analyzer is 1MHz and the video bandwidth is  $\geq 1/T$  (Duty cycle < 98%) or 10Hz (Duty cycle > 98%) for Average detection (AV) at frequency above 1GHz.
4. All modes of operation were investigated and the worst-case emissions are reported.

### 3.1.5 DEVIATION FROM TEST STANDARD

No deviation.



### 3.1.6 TEST SETUP

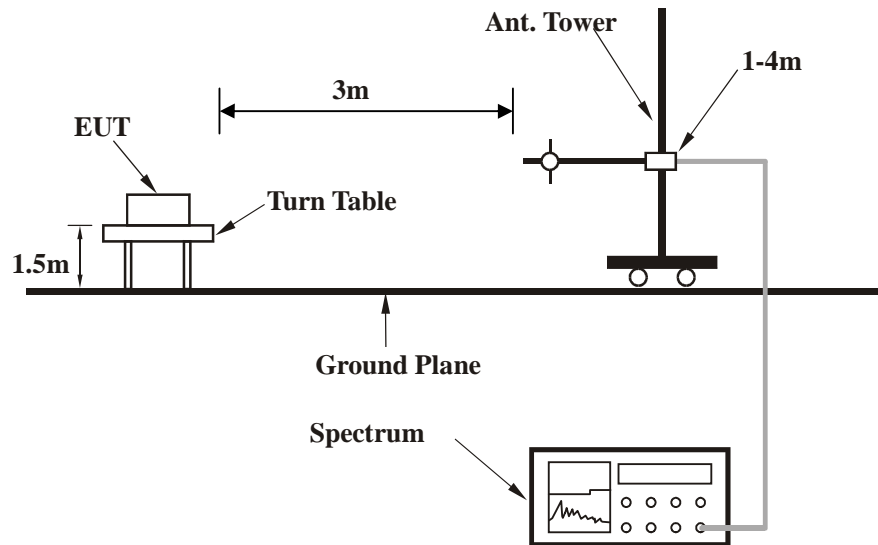

For the actual test configuration, please refer to the attached file (Test Setup Photo).

### 3.1.7 EUT OPERATING CONDITION

- Set the EUT under full load condition and placed them on a testing table.
- Set the transmitter part of EUT under transmission condition continuously at specific channel frequency.
- The necessary accessories enable the EUT in full functions.



### 3.1.8 TEST RESULTS

#### BELOW 1GHz WORST-CASE DATA

##### 802.11a

<b>CHANNEL</b>	TX Channel 36	<b>DETECTOR FUNCTION</b>	Quasi-Peak (QP)
<b>FREQUENCY RANGE</b>	30MHz ~ 1GHz		

ANTENNA POLARITY & TEST DISTANCE: HORIZONTAL AT 3 M								
NO.	FREQ. (MHz)	EMISSION LEVEL (dBuV/m)	LIMIT (dBuV/m)	MARGIN (dB)	ANTENNA HEIGHT (cm)	TABLE ANGLE (Degree)	RAW VALUE (dBuV)	CORRECTION FACTOR (dB/m)
1	127.82	27.50	43.50	-16.00	200	0	45.03	-17.53
2	143.07	26.34	43.50	-17.16	200	0	44.14	-17.80
3	270.32	23.99	46.00	-22.01	200	0	38.50	-14.51
4	319.45	27.11	46.00	-18.89	200	0	41.02	-13.91
5	712.70	32.65	46.00	-13.35	200	0	35.55	-2.90
6	723.22	31.57	46.00	-14.43	200	0	33.91	-2.34

#### REMARKS:

1. Emission level (dBuV/m) = Raw Value (dBuV) + Correction Factor (dB/m).
2. Correction Factor (dB/m) = Antenna Factor (dB/m) + Cable Factor (dB).
3. The other emission levels were very low against the limit.
4. Margin value = Emission level – Limit value.

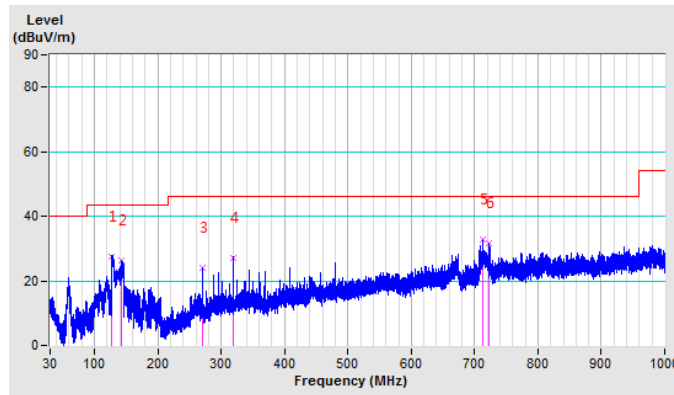



<b>CHANNEL</b>	TX Channel 36	<b>DETECTOR FUNCTION</b>	Quasi-Peak (QP)
<b>FREQUENCY RANGE</b>	30MHz ~ 1GHz		

ANTENNA POLARITY & TEST DISTANCE: VERTICAL AT 3 M								
NO.	FREQ. (MHz)	EMISSION LEVEL (dBuV/m)	LIMIT (dBuV/m)	MARGIN (dB)	ANTENNA HEIGHT (m)	TABLE ANGLE (Degree)	RAW VALUE (dBuV)	CORRECTION FACTOR (dB/m)
1	59.13	33.70	40.00	-6.30	200	0	58.37	-24.67
2	94.38	25.87	43.50	-17.63	200	0	45.38	-19.51
3	151.98	26.96	43.50	-16.54	200	0	44.09	-17.13
4	161.92	29.26	43.50	-14.24	200	0	47.03	-17.77
5	270.32	23.91	46.00	-22.09	200	0	38.42	-14.51
6	407.97	25.23	46.00	-20.77	200	0	34.57	-9.34

**REMARKS:**

1. Emission level (dBuV/m) = Raw Value (dBuV) + Correction Factor (dB/m).
2. Correction Factor (dB/m) = Antenna Factor (dB/m) + Cable Factor (dB).
3. The other emission levels were very low against the limit.
4. Margin value = Emission level – Limit value.

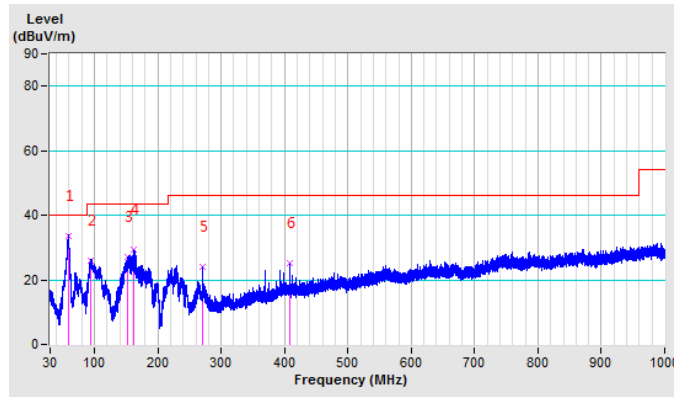



Band 1 (5150-5250MHz):

ABOVE 1GHz DATA

802.11a

CHANNEL	TX Channel 36	DETECTOR FUNCTION	Peak (PK)
FREQUENCY RANGE	1GHz ~ 40GHz		Average (AV)

ANTENNA POLARITY & TEST DISTANCE: HORIZONTAL AT 3 M

NO.	FREQ. (MHz)	EMISSION LEVEL (dBuV/m)	LIMIT (dBuV/m)	MARGIN (dB)	ANTENNA HEIGHT (m)	TABLE ANGLE (Degree)	RAW VALUE (dBuV)	CORRECTION FACTOR (dB/m)
1	5150.00	51.6 PK	68.2	-16.6	2.03 H	278	43.37	8.27
2	*5180.00	99.7 PK			2.03 H	278	91.38	8.32
3	*5180.00	89.5 AV			2.03 H	278	81.17	8.32
4	#10360.00	54.6 PK	74.0	-19.4	1.56 H	302	35.43	19.21
5	#10360.00	40.4 AV	54.0	-13.6	1.56 H	302	21.15	19.21
6	15540.00	59.7 PK	74.0	-14.3	1.95 H	48	38.23	21.45
7	15540.00	44.9 AV	54.0	-9.1	1.95 H	48	23.48	21.45

ANTENNA POLARITY & TEST DISTANCE: VERTICAL AT 3 M

NO.	FREQ. (MHz)	EMISSION LEVEL (dBuV/m)	LIMIT (dBuV/m)	MARGIN (dB)	ANTENNA HEIGHT (m)	TABLE ANGLE (Degree)	RAW VALUE (dBuV)	CORRECTION FACTOR (dB/m)
1	5150.00	46.9 PK	68.3	-21.3	1.49 V	253	38.67	8.27
2	*5180.00	96.7 PK			1.49 V	253	88.42	8.32
3	*5180.00	85.7 AV			1.49 V	253	77.36	8.32
4	#10360.00	54.6 PK	74.0	-19.4	1.63 V	274	35.34	19.21
5	#10360.00	40.6 AV	54.0	-13.4	1.63 V	274	21.35	19.21
6	15540.00	59.5 PK	74.0	-14.5	1.00 V	259	38.04	21.45
7	15540.00	44.6 AV	54.0	-9.4	1.00 V	259	23.11	21.45

REMARKS:

1. Emission level (dBuV/m) = Raw Value (dBuV) + Correction Factor (dB/m).
2. Correction Factor (dB/m) = Antenna Factor (dB/m) + Cable Factor (dB).
3. The other emission levels were very low against the limit.
4. Margin value = Emission level – Limit value.
5. " \* ": Fundamental frequency.
6. " # ": The radiated frequency is out of the restricted band.



CHANNEL	TX Channel 40	DETECTOR FUNCTION	Peak (PK)
FREQUENCY RANGE	1GHz ~ 40GHz		Average (AV)

ANTENNA POLARITY & TEST DISTANCE: HORIZONTAL AT 3 M

NO.	FREQ. (MHz)	EMISSION LEVEL (dBuV/m)	LIMIT (dBuV/m)	MARGIN (dB)	ANTENNA HEIGHT (m)	TABLE ANGLE (Degree)	RAW VALUE (dBuV)	CORRECTION FACTOR (dB/m)
1	*5200.00	100.7 PK			1.95 H	274	92.40	8.34
2	*5200.00	89.3 AV			1.95 H	274	80.97	8.34
3	#10400.00	53.6 PK	74.0	-20.4	1.49 H	153	34.30	19.31
4	#10400.00	40.6 AV	54.0	-13.4	1.49 H	153	21.26	19.31
5	15600.00	59.6 PK	74.0	-14.4	1.95 H	302	38.04	21.59
6	15600.00	43.5 AV	54.0	-10.5	1.95 H	302	21.92	21.59

ANTENNA POLARITY & TEST DISTANCE: VERTICAL AT 3 M

NO.	FREQ. (MHz)	EMISSION LEVEL (dBuV/m)	LIMIT (dBuV/m)	MARGIN (dB)	ANTENNA HEIGHT (m)	TABLE ANGLE (Degree)	RAW VALUE (dBuV)	CORRECTION FACTOR (dB/m)
1	*5200.00	96.8 PK			1.96 V	237	88.49	8.34
2	*5200.00	85.2 AV			1.96 V	237	76.87	8.34
3	#10400.00	54.9 PK	74.0	-19.1	1.65 V	291	35.54	19.31
4	#10400.00	40.9 AV	54.0	-13.1	1.65 V	291	21.63	19.31
5	15600.00	58.8 PK	74.0	-15.2	1.64 V	185	37.20	21.59
6	15600.00	44.3 AV	54.0	-9.7	1.64 V	185	22.72	21.59

REMARKS:

1. Emission level (dBuV/m) = Raw Value (dBuV) + Correction Factor (dB/m).
2. Correction Factor (dB/m) = Antenna Factor (dB/m) + Cable Factor (dB).
3. The other emission levels were very low against the limit.
4. Margin value = Emission level – Limit value.
5. " \* ": Fundamental frequency.
6. " # ": The radiated frequency is out of the restricted band.



<b>CHANNEL</b>	TX Channel 48	<b>DETECTOR FUNCTION</b>	Peak (PK)
<b>FREQUENCY RANGE</b>	1GHz ~ 40GHz		Average (AV)

**ANTENNA POLARITY & TEST DISTANCE: HORIZONTAL AT 3 M**

NO.	FREQ. (MHz)	EMISSION LEVEL (dBuV/m)	LIMIT (dBuV/m)	MARGIN (dB)	ANTENNA HEIGHT (m)	TABLE ANGLE (Degree)	RAW VALUE (dBuV)	CORRECTION FACTOR (dB/m)
1	*5240.00	99.7 PK			1.00 H	285	91.34	8.40
2	*5240.00	88.8 AV			1.00 H	285	80.35	8.40
3	#10480.00	53.7 PK	74.0	-20.3	4.00 H	274	34.19	19.50
4	#10480.00	40.6 AV	54.0	-13.4	4.00 H	274	21.07	19.50
5	15720.00	59.5 PK	74.0	-14.5	1.85 H	234	37.59	21.87
6	15720.00	43.6 AV	54.0	-10.4	1.85 H	234	21.71	21.87

**ANTENNA POLARITY & TEST DISTANCE: VERTICAL AT 3 M**

NO.	FREQ. (MHz)	EMISSION LEVEL (dBuV/m)	LIMIT (dBuV/m)	MARGIN (dB)	ANTENNA HEIGHT (m)	TABLE ANGLE (Degree)	RAW VALUE (dBuV)	CORRECTION FACTOR (dB/m)
1	*5240.00	90.8 PK			1.66 V	169	82.41	8.40
2	*5240.00	79.9 AV			1.66 V	169	71.54	8.40
3	#10480.00	53.6 PK	74.0	-20.4	1.85 V	233	34.05	19.50
4	#10480.00	41.5 AV	54.0	-12.5	1.85 V	233	22.01	19.50
5	15720.00	58.6 PK	74.0	-15.4	1.95 V	253	36.77	21.87
6	15720.00	44.6 AV	54.0	-9.4	1.95 V	253	22.75	21.87

**REMARKS:**

1. Emission level (dBuV/m) = Raw Value (dBuV) + Correction Factor (dB/m).
2. Correction Factor (dB/m) = Antenna Factor (dB/m) + Cable Factor (dB).
3. The other emission levels were very low against the limit.
4. Margin value = Emission level – Limit value.
5. " \* ": Fundamental frequency.
6. " # ": The radiated frequency is out of the restricted band.



802.11n (20MHz)

CHANNEL	TX Channel 36	DETECTOR FUNCTION	Peak (PK)
FREQUENCY RANGE	1GHz ~ 40GHz		Average (AV)

ANTENNA POLARITY & TEST DISTANCE: HORIZONTAL AT 3 M

NO.	FREQ. (MHz)	EMISSION LEVEL (dBuV/m)	LIMIT (dBuV/m)	MARGIN (dB)	ANTENNA HEIGHT (m)	TABLE ANGLE (Degree)	RAW VALUE (dBuV)	CORRECTION FACTOR (dB/m)
1	5150.00	52.6 PK	68.2	-15.6	1.94 H	278	44.37	8.27
2	*5180.00	99.4 PK			1.94 H	278	91.10	8.32
3	*5180.00	89.1 AV			1.94 H	278	80.78	8.32
4	#10360.00	55.0 PK	74.0	-19.0	1.56 H	201	35.81	19.21
5	#10360.00	41.7 AV	54.0	-12.3	1.56 H	201	22.44	19.21
6	15540.00	58.5 PK	74.0	-15.5	2.35 H	121	37.02	21.45
7	15540.00	45.1 AV	54.0	-8.9	2.35 H	121	23.61	21.45

ANTENNA POLARITY & TEST DISTANCE: VERTICAL AT 3 M

NO.	FREQ. (MHz)	EMISSION LEVEL (dBuV/m)	LIMIT (dBuV/m)	MARGIN (dB)	ANTENNA HEIGHT (m)	TABLE ANGLE (Degree)	RAW VALUE (dBuV)	CORRECTION FACTOR (dB/m)
1	5150.00	47.4 PK	68.2	-20.8	1.22 V	251	39.09	8.27
2	*5180.00	95.5 PK			1.22 V	251	87.13	8.32
3	*5180.00	84.6 AV			1.22 V	251	76.30	8.32
4	#10360.00	55.0 PK	74.0	-19.0	1.85 V	226	35.81	19.21
5	#10360.00	40.1 AV	54.0	-13.9	1.85 V	226	20.89	19.21
6	15540.00	60.5 PK	74.0	-13.5	2.78 V	261	39.07	21.45
7	15540.00	44.9 AV	54.0	-9.1	2.78 V	261	23.46	21.45

REMARKS:

1. Emission level (dBuV/m) = Raw Value (dBuV) + Correction Factor (dB/m).
2. Correction Factor (dB/m) = Antenna Factor (dB/m) + Cable Factor (dB).
3. The other emission levels were very low against the limit.
4. Margin value = Emission level – Limit value.
5. " \* ": Fundamental frequency.
6. " # ": The radiated frequency is out of the restricted band.



CHANNEL	TX Channel 40	DETECTOR FUNCTION	Peak (PK)
FREQUENCY RANGE	1GHz ~ 40GHz		Average (AV)

ANTENNA POLARITY & TEST DISTANCE: HORIZONTAL AT 3 M

NO.	FREQ. (MHz)	EMISSION LEVEL (dBuV/m)	LIMIT (dBuV/m)	MARGIN (dB)	ANTENNA HEIGHT (m)	TABLE ANGLE (Degree)	RAW VALUE (dBuV)	CORRECTION FACTOR (dB/m)
1	*5200.00	100.1 PK			1.65 H	230	91.73	8.34
2	*5200.00	88.5 AV			1.65 H	230	80.16	8.34
3	#10400.00	53.7 PK	74.0	-20.3	1.25 H	239	34.35	19.31
4	#10400.00	40.5 AV	54.0	-13.5	1.25 H	239	21.21	19.31
5	15600.00	58.5 PK	74.0	-15.5	2.36 H	120	36.87	21.59
6	15600.00	43.6 AV	54.0	-10.4	2.36 H	120	21.99	21.59

ANTENNA POLARITY & TEST DISTANCE: VERTICAL AT 3 M

NO.	FREQ. (MHz)	EMISSION LEVEL (dBuV/m)	LIMIT (dBuV/m)	MARGIN (dB)	ANTENNA HEIGHT (m)	TABLE ANGLE (Degree)	RAW VALUE (dBuV)	CORRECTION FACTOR (dB/m)
1	*5200.00	95.4 PK			1.00 V	238	87.02	8.34
2	*5200.00	84.0 AV			1.00 V	238	75.61	8.34
3	#10400.00	54.9 PK	74.0	-19.1	1.68 V	246	35.58	19.31
4	#10400.00	40.9 AV	54.0	-13.1	1.68 V	246	21.59	19.31
5	15600.00	58.6 PK	74.0	-15.4	1.47 V	256	37.05	21.59
6	15600.00	44.6 AV	54.0	-9.4	1.47 V	256	22.99	21.59

REMARKS:

1. Emission level (dBuV/m) = Raw Value (dBuV) + Correction Factor (dB/m).
2. Correction Factor (dB/m) = Antenna Factor (dB/m) + Cable Factor (dB).
3. The other emission levels were very low against the limit.
4. Margin value = Emission level – Limit value.
5. " \* ": Fundamental frequency.
6. " # ": The radiated frequency is out of the restricted band.



<b>CHANNEL</b>	TX Channel 48	<b>DETECTOR FUNCTION</b>	Peak (PK)
<b>FREQUENCY RANGE</b>	1GHz ~ 40GHz		Average (AV)

<b>ANTENNA POLARITY &amp; TEST DISTANCE: HORIZONTAL AT 3 M</b>								
NO.	FREQ. (MHz)	EMISSION LEVEL (dBuV/m)	LIMIT (dBuV/m)	MARGIN (dB)	ANTENNA HEIGHT (m)	TABLE ANGLE (Degree)	RAW VALUE (dBuV)	CORRECTION FACTOR (dB/m)
1	*5240.00	96.5 PK			1.49 H	247	88.08	8.40
2	*5240.00	85.2 AV			1.49 H	247	76.79	8.40
3	#10480.00	53.6 PK	74.0	-20.4	2.16 H	201	34.11	19.50
4	#10480.00	40.6 AV	54.0	-13.4	2.16 H	201	21.08	19.50
5	15720.00	58.6 PK	74.0	-15.4	1.69 H	248	36.77	21.87
6	15720.00	44.7 AV	54.0	-9.3	1.69 H	248	22.78	21.87
<b>ANTENNA POLARITY &amp; TEST DISTANCE: VERTICAL AT 3 M</b>								
NO.	FREQ. (MHz)	EMISSION LEVEL (dBuV/m)	LIMIT (dBuV/m)	MARGIN (dB)	ANTENNA HEIGHT (m)	TABLE ANGLE (Degree)	RAW VALUE (dBuV)	CORRECTION FACTOR (dB/m)
1	*5240.00	90.6 PK			1.36 V	248	82.15	8.40
2	*5240.00	79.9 AV			1.36 V	248	71.45	8.40
3	#10480.00	53.2 PK	74.0	-20.8	1.96 V	235	33.72	19.50
4	#10480.00	41.3 AV	54.0	-12.7	1.96 V	235	21.80	19.50
5	15720.00	58.2 PK	74.0	-15.8	1.54 V	231	36.37	21.87
6	15720.00	44.3 AV	54.0	-9.7	1.54 V	231	22.45	21.87

**REMARKS:**

1. Emission level (dBuV/m) = Raw Value (dBuV) + Correction Factor (dB/m).
2. Correction Factor (dB/m) = Antenna Factor (dB/m) + Cable Factor (dB).
3. The other emission levels were very low against the limit.
4. Margin value = Emission level – Limit value.
5. " \* ": Fundamental frequency.
6. " # ": The radiated frequency is out of the restricted band.



**802.11n (40MHz)**

<b>CHANNEL</b>	TX Channel 38	<b>DETECTOR FUNCTION</b>	Peak (PK)
<b>FREQUENCY RANGE</b>	1GHz ~ 40GHz		Average (AV)

**ANTENNA POLARITY & TEST DISTANCE: HORIZONTAL AT 3 M**

NO.	FREQ. (MHz)	EMISSION LEVEL (dBuV/m)	LIMIT (dBuV/m)	MARGIN (dB)	ANTENNA HEIGHT (m)	TABLE ANGLE (Degree)	RAW VALUE (dBuV)	CORRECTION FACTOR (dB/m)
1	5150.00	60.4 PK	68.2	-7.8	1.00 H	200	52.13	8.27
2	*5190.00	96.9 PK			1.00 H	200	88.59	8.33
3	*5190.00	85.0 AV			1.00 H	200	76.64	8.33
4	#10380.00	55.6 PK	74.0	-18.4	1.63 H	275	36.35	19.26
5	#10380.00	40.5 AV	54.0	-13.5	1.63 H	275	21.26	19.26
6	15570.00	59.6 PK	74.0	-14.4	1.68 H	201	38.12	21.52
7	15570.00	43.6 AV	54.0	-10.4	1.68 H	201	22.07	21.52

**ANTENNA POLARITY & TEST DISTANCE: VERTICAL AT 3 M**

NO.	FREQ. (MHz)	EMISSION LEVEL (dBuV/m)	LIMIT (dBuV/m)	MARGIN (dB)	ANTENNA HEIGHT (m)	TABLE ANGLE (Degree)	RAW VALUE (dBuV)	CORRECTION FACTOR (dB/m)
1	5150.00	54.6 PK	68.2	-13.6	1.64 V	285	46.29	8.27
2	*5190.00	92.8 PK			1.64 V	285	84.47	8.33
3	*5190.00	80.9 AV			1.64 V	285	72.57	8.33
4	#10380.00	53.3 PK	74.0	-20.7	1.29 V	286	33.99	19.26
5	#10380.00	41.3 AV	54.0	-12.7	1.29 V	286	22.00	19.26
6	15570.00	60.5 PK	74.0	-13.5	1.94 V	254	39.02	21.52
7	15570.00	44.6 AV	54.0	-9.4	1.94 V	254	23.07	21.52

**REMARKS:**

1. Emission level (dBuV/m) = Raw Value (dBuV) + Correction Factor (dB/m).
2. Correction Factor (dB/m) = Antenna Factor (dB/m) + Cable Factor (dB).
3. The other emission levels were very low against the limit.
4. Margin value = Emission level – Limit value.
5. " \* ": Fundamental frequency.
6. " # ": The radiated frequency is out of the restricted band.



<b>CHANNEL</b>	TX Channel 46	<b>DETECTOR FUNCTION</b>	Peak (PK)
<b>FREQUENCY RANGE</b>	1GHz ~ 40GHz		Average (AV)

**ANTENNA POLARITY & TEST DISTANCE: HORIZONTAL AT 3 M**

NO.	FREQ. (MHz)	EMISSION LEVEL (dBuV/m)	LIMIT (dBuV/m)	MARGIN (dB)	ANTENNA HEIGHT (m)	TABLE ANGLE (Degree)	RAW VALUE (dBuV)	CORRECTION FACTOR (dB/m)
1	*5230.00	96.4 PK			1.64 H	258	87.97	8.39
2	*5230.00	83.9 AV			1.64 H	258	75.55	8.39
3	#10460.00	55.9 PK	74.0	-18.1	1.58 H	246	36.47	19.46
4	#10460.00	41.3 AV	54.0	-12.7	1.58 H	246	21.79	19.46
5	15690.00	60.5 PK	74.0	-13.5	1.52 H	324	38.74	21.80
6	15690.00	45.7 AV	54.0	-8.3	1.52 H	324	23.87	21.80

**ANTENNA POLARITY & TEST DISTANCE: VERTICAL AT 3 M**

NO.	FREQ. (MHz)	EMISSION LEVEL (dBuV/m)	LIMIT (dBuV/m)	MARGIN (dB)	ANTENNA HEIGHT (m)	TABLE ANGLE (Degree)	RAW VALUE (dBuV)	CORRECTION FACTOR (dB/m)
1	*5230.00	88.2 PK			1.16 V	255	79.78	8.39
2	*5230.00	76.4 AV			1.16 V	255	68.00	8.39
3	#10460.00	53.3 PK	74.0	-20.7	1.65 V	210	33.80	19.46
4	#10460.00	41.3 AV	54.0	-12.7	1.65 V	210	21.79	19.46
5	15690.00	60.5 PK	74.0	-13.5	2.13 V	150	38.70	21.80
6	15690.00	45.6 AV	54.0	-8.4	2.13 V	150	23.81	21.80

**REMARKS:**

1. Emission level (dBuV/m) = Raw Value (dBuV) + Correction Factor (dB/m).
2. Correction Factor (dB/m) = Antenna Factor (dB/m) + Cable Factor (dB).
3. The other emission levels were very low against the limit.
4. Margin value = Emission level – Limit value.
5. " \* ": Fundamental frequency.
6. " # ": The radiated frequency is out of the restricted band.



**802.11ac (80MHz)**

<b>CHANNEL</b>	TX Channel 42	<b>DETECTOR FUNCTION</b>	Peak (PK)
<b>FREQUENCY RANGE</b>	1GHz ~ 40GHz		Average (AV)

**ANTENNA POLARITY & TEST DISTANCE: HORIZONTAL AT 3 M**

NO.	FREQ. (MHz)	EMISSION LEVEL (dBuV/m)	LIMIT (dBuV/m)	MARGIN (dB)	ANTENNA HEIGHT (m)	TABLE ANGLE (Degree)	RAW VALUE (dBuV)	CORRECTION FACTOR (dB/m)
1	5150.00	67.2 PK	68.2	-1.0	1.01 H	235	58.93	8.27
2	*5210.00	93.6 PK			1.01 H	235	85.26	8.35
3	*5210.00	80.3 AV			1.01 H	235	71.92	8.35
4	#10420.00	53.7 PK	74.0	-20.3	1.52 H	235	34.32	19.35
5	#10420.00	39.6 AV	54.0	-14.4	1.52 H	235	20.26	19.35
6	15630.00	60.0 PK	74.0	-14.0	1.85 H	295	38.36	21.66
7	15630.00	44.6 AV	54.0	-9.4	1.85 H	295	22.95	21.66

**ANTENNA POLARITY & TEST DISTANCE: VERTICAL AT 3 M**

NO.	FREQ. (MHz)	EMISSION LEVEL (dBuV/m)	LIMIT (dBuV/m)	MARGIN (dB)	ANTENNA HEIGHT (m)	TABLE ANGLE (Degree)	RAW VALUE (dBuV)	CORRECTION FACTOR (dB/m)
1	5150.00	57.9 PK	68.2	-10.3	1.94 V	263	49.64	8.27
2	*5210.00	88.6 PK			1.94 V	263	80.29	8.35
3	*5210.00	75.9 AV			1.94 V	263	67.57	8.35
4	#10420.00	55.8 PK	74.0	-18.2	1.74 V	253	36.49	19.35
5	#10420.00	41.8 AV	54.0	-12.2	1.74 V	253	22.45	19.35
6	15630.00	58.7 PK	74.0	-15.3	1.85 V	224	37.08	21.66
7	15630.00	45.8 AV	54.0	-8.2	1.85 V	224	24.15	21.66

**REMARKS:**

1. Emission level (dBuV/m) = Raw Value (dBuV) + Correction Factor (dB/m).
2. Correction Factor (dB/m) = Antenna Factor (dB/m) + Cable Factor (dB).
3. The other emission levels were very low against the limit.
4. Margin value = Emission level – Limit value.
5. " \* ": Fundamental frequency.
6. " # ": The radiated frequency is out of the restricted band.



Band 2 (5250-5350MHz):

ABOVE 1GHz DATA

802.11a

CHANNEL	TX Channel 52	DETECTOR FUNCTION	Peak (PK)
FREQUENCY RANGE	1GHz ~ 40GHz		Average (AV)

ANTENNA POLARITY & TEST DISTANCE: HORIZONTAL AT 3 M								
NO.	FREQ. (MHz)	EMISSION LEVEL (dBuV/m)	LIMIT (dBuV/m)	MARGIN (dB)	ANTENNA HEIGHT (m)	TABLE ANGLE (Degree)	RAW VALUE (dBuV)	CORRECTION FACTOR (dB/m)
1	*5260.00	95.7 PK			1.17 H	218	87.22	8.44
2	*5260.00	84.8 AV			1.17 H	218	76.37	8.44
3	#10520.00	55.7 PK	74.0	-18.3	1.67 H	285	36.11	19.56
4	#10520.00	42.5 AV	54.0	-11.5	1.67 H	285	22.95	19.56
5	15780.00	58.4 PK	74.0	-15.6	2.14 H	230	36.40	22.02
6	15780.00	44.9 AV	54.0	-9.1	2.14 H	230	22.83	22.02

ANTENNA POLARITY & TEST DISTANCE: VERTICAL AT 3 M								
NO.	FREQ. (MHz)	EMISSION LEVEL (dBuV/m)	LIMIT (dBuV/m)	MARGIN (dB)	ANTENNA HEIGHT (m)	TABLE ANGLE (Degree)	RAW VALUE (dBuV)	CORRECTION FACTOR (dB/m)
1	*5260.00	91.2 PK			1.16 V	230	82.72	8.44
2	*5260.00	79.4 AV			1.16 V	230	70.93	8.44
3	#10520.00	54.8 PK	74.0	-19.2	1.15 V	278	35.24	19.56
4	#10520.00	40.5 AV	54.0	-13.5	1.15 V	278	20.95	19.56
5	15780.00	60.8 PK	74.0	-13.2	1.49 V	281	38.82	22.02
6	15780.00	44.5 AV	54.0	-9.5	1.49 V	281	22.49	22.02

REMARKS:

1. Emission level (dBuV/m) = Raw Value (dBuV) + Correction Factor (dB/m).
2. Correction Factor (dB/m) = Antenna Factor (dB/m) + Cable Factor (dB).
3. The other emission levels were very low against the limit.
4. Margin value = Emission level – Limit value.
5. " \* ": Fundamental frequency.
6. " # ": The radiated frequency is out of the restricted band.



<b>CHANNEL</b>	TX Channel 60	<b>DETECTOR FUNCTION</b>	Peak (PK)
<b>FREQUENCY RANGE</b>	1GHz ~ 40GHz		Average (AV)

**ANTENNA POLARITY & TEST DISTANCE: HORIZONTAL AT 3 M**

NO.	FREQ. (MHz)	EMISSION LEVEL (dBuV/m)	LIMIT (dBuV/m)	MARGIN (dB)	ANTENNA HEIGHT (m)	TABLE ANGLE (Degree)	RAW VALUE (dBuV)	CORRECTION FACTOR (dB/m)
1	*5300.00	99.3 PK			1.63 H	270	90.84	8.46
2	*5300.00	87.6 AV			1.63 H	270	79.15	8.46
3	#10600.00	55.2 PK	74.0	-18.8	1.94 H	352	35.58	19.58
4	#10600.00	42.0 AV	54.0	-12.0	1.94 H	352	22.45	19.58
5	15900.00	60.4 PK	74.0	-13.6	2.16 H	185	38.21	22.16
6	15900.00	44.6 AV	54.0	-9.4	2.16 H	185	22.42	22.16

**ANTENNA POLARITY & TEST DISTANCE: VERTICAL AT 3 M**

NO.	FREQ. (MHz)	EMISSION LEVEL (dBuV/m)	LIMIT (dBuV/m)	MARGIN (dB)	ANTENNA HEIGHT (m)	TABLE ANGLE (Degree)	RAW VALUE (dBuV)	CORRECTION FACTOR (dB/m)
1	*5300.00	90.9 PK			2.00 V	158	82.41	8.46
2	*5300.00	79.6 AV			2.00 V	158	71.17	8.46
3	#10600.00	54.6 PK	74.0	-19.4	1.84 V	241	35.06	19.58
4	#10600.00	41.1 AV	54.0	-12.9	1.84 V	241	21.50	19.58
5	15900.00	59.7 PK	74.0	-14.3	1.57 V	248	37.51	22.16
6	15900.00	45.6 AV	54.0	-8.4	1.57 V	248	23.45	22.16

**REMARKS:**

1. Emission level (dBuV/m) = Raw Value (dBuV) + Correction Factor (dB/m).
2. Correction Factor (dB/m) = Antenna Factor (dB/m) + Cable Factor (dB).
3. The other emission levels were very low against the limit.
4. Margin value = Emission level – Limit value.
5. " \* ": Fundamental frequency.
6. " # ": The radiated frequency is out of the restricted band.



CHANNEL	TX Channel 64	DETECTOR FUNCTION	Peak (PK)
FREQUENCY RANGE	1GHz ~ 40GHz		Average (AV)

ANTENNA POLARITY & TEST DISTANCE: HORIZONTAL AT 3 M

NO.	FREQ. (MHz)	EMISSION LEVEL (dBuV/m)	LIMIT (dBuV/m)	MARGIN (dB)	ANTENNA HEIGHT (m)	TABLE ANGLE (Degree)	RAW VALUE (dBuV)	CORRECTION FACTOR (dB/m)
1	*5320.00	98.2 PK			1.00 H	185	89.67	8.52
2	*5320.00	87.7 AV			1.00 H	185	79.15	8.52
3	5350.00	48.5 PK	68.2	-19.7	1.00 H	185	39.93	8.57
4	10640.00	55.9 PK	74.0	-18.1	1.84 H	263	36.25	19.62
5	10640.00	42.5 AV	54.0	-11.5	1.84 H	263	22.89	19.62
6	15960.00	59.3 PK	74.0	-14.7	1.65 H	274	36.88	22.44
7	15960.00	45.0 AV	54.0	-9.0	1.65 H	274	22.51	22.44

ANTENNA POLARITY & TEST DISTANCE: VERTICAL AT 3 M

NO.	FREQ. (MHz)	EMISSION LEVEL (dBuV/m)	LIMIT (dBuV/m)	MARGIN (dB)	ANTENNA HEIGHT (m)	TABLE ANGLE (Degree)	RAW VALUE (dBuV)	CORRECTION FACTOR (dB/m)
1	*5320.00	96.7 PK			1.00 V	256	88.13	8.52
2	*5320.00	86.2 AV			1.00 V	256	77.68	8.52
3	5350.00	47.8 PK	68.2	-20.4	1.00 V	256	39.27	8.57
4	10640.00	55.2 PK	74.0	-18.8	1.56 V	298	35.62	19.62
5	10640.00	41.6 AV	54.0	-12.4	1.56 V	298	22.00	19.62
6	15960.00	60.6 PK	74.0	-13.4	1.98 V	248	38.14	22.44
7	15960.00	45.6 AV	54.0	-8.4	1.98 V	248	23.19	22.44

REMARKS:

1. Emission level (dBuV/m) = Raw Value (dBuV) + Correction Factor (dB/m).
2. Correction Factor (dB/m) = Antenna Factor (dB/m) + Cable Factor (dB).
3. The other emission levels were very low against the limit.
4. Margin value = Emission level – Limit value.
5. " \* ": Fundamental frequency.



802.11n (20MHz)

CHANNEL	TX Channel 52	DETECTOR FUNCTION	Peak (PK)
FREQUENCY RANGE	1GHz ~ 40GHz		Average (AV)

ANTENNA POLARITY & TEST DISTANCE: HORIZONTAL AT 3 M

NO.	FREQ. (MHz)	EMISSION LEVEL (dBuV/m)	LIMIT (dBuV/m)	MARGIN (dB)	ANTENNA HEIGHT (m)	TABLE ANGLE (Degree)	RAW VALUE (dBuV)	CORRECTION FACTOR (dB/m)
1	*5260.00	101.9 PK			1.56 H	295	93.43	8.44
2	*5260.00	91.0 AV			1.56 H	295	82.52	8.44
3	#10520.00	51.5 PK	74.0	-22.5	1.85 H	263	31.96	19.56
4	#10520.00	41.5 AV	54.0	-12.5	1.85 H	263	21.95	19.56
5	15780.00	60.3 PK	74.0	-13.7	1.65 H	254	38.31	22.02
6	15780.00	46.4 AV	54.0	-7.6	1.65 H	254	24.36	22.02

ANTENNA POLARITY & TEST DISTANCE: VERTICAL AT 3 M

NO.	FREQ. (MHz)	EMISSION LEVEL (dBuV/m)	LIMIT (dBuV/m)	MARGIN (dB)	ANTENNA HEIGHT (m)	TABLE ANGLE (Degree)	RAW VALUE (dBuV)	CORRECTION FACTOR (dB/m)
1	*5260.00	100.6 PK			1.53 V	270	92.16	8.44
2	*5260.00	89.7 AV			1.53 V	270	81.28	8.44
3	#10520.00	53.3 PK	74.0	-20.7	1.54 V	271	33.71	19.56
4	#10520.00	42.3 AV	54.0	-11.7	1.54 V	271	22.74	19.56
5	15780.00	59.3 PK	74.0	-14.7	1.69 V	253	37.30	22.02
6	15780.00	47.3 AV	54.0	-6.7	1.69 V	253	25.23	22.02

REMARKS:

1. Emission level (dBuV/m) = Raw Value (dBuV) + Correction Factor (dB/m).
2. Correction Factor (dB/m) = Antenna Factor (dB/m) + Cable Factor (dB).
3. The other emission levels were very low against the limit.
4. Margin value = Emission level – Limit value.
5. " \* ": Fundamental frequency.
6. " # ": The radiated frequency is out of the restricted band.



<b>CHANNEL</b>	TX Channel 60	<b>DETECTOR FUNCTION</b>	Peak (PK)
<b>FREQUENCY RANGE</b>	1GHz ~ 40GHz		Average (AV)

**ANTENNA POLARITY & TEST DISTANCE: HORIZONTAL AT 3 M**

NO.	FREQ. (MHz)	EMISSION LEVEL (dBuV/m)	LIMIT (dBuV/m)	MARGIN (dB)	ANTENNA HEIGHT (m)	TABLE ANGLE (Degree)	RAW VALUE (dBuV)	CORRECTION FACTOR (dB/m)
1	*5300.00	102.3 PK			2.10 H	185	93.84	8.46
2	*5300.00	91.4 AV			2.10 H	185	82.93	8.46
3	#10600.00	52.9 PK	74.0	-21.1	1.14 H	278	33.30	19.58
4	#10600.00	41.6 AV	54.0	-12.4	1.14 H	278	22.00	19.58
5	15900.00	60.3 PK	74.0	-13.7	1.42 H	263	38.16	22.16
6	15900.00	45.6 AV	54.0	-8.4	1.42 H	263	23.45	22.16

**ANTENNA POLARITY & TEST DISTANCE: VERTICAL AT 3 M**

NO.	FREQ. (MHz)	EMISSION LEVEL (dBuV/m)	LIMIT (dBuV/m)	MARGIN (dB)	ANTENNA HEIGHT (m)	TABLE ANGLE (Degree)	RAW VALUE (dBuV)	CORRECTION FACTOR (dB/m)
1	*5300.00	101.7 PK			1.49 V	278	93.24	8.46
2	*5300.00	90.0 AV			1.49 V	278	81.53	8.46
3	#10600.00	52.6 PK	74.0	-21.4	1.98 V	203	33.06	19.58
4	#10600.00	41.5 AV	54.0	-12.5	1.98 V	203	21.92	19.58
5	15900.00	59.8 PK	74.0	-14.2	1.69 V	245	37.68	22.16
6	15900.00	45.8 AV	54.0	-8.2	1.69 V	245	23.64	22.16

**REMARKS:**

1. Emission level (dBuV/m) = Raw Value (dBuV) + Correction Factor (dB/m).
2. Correction Factor (dB/m) = Antenna Factor (dB/m) + Cable Factor (dB).
3. The other emission levels were very low against the limit.
4. Margin value = Emission level – Limit value.
5. " \* ": Fundamental frequency.
6. " # ": The radiated frequency is out of the restricted band.



CHANNEL	TX Channel 64	DETECTOR FUNCTION	Peak (PK)
FREQUENCY RANGE	1GHz ~ 40GHz		Average (AV)

ANTENNA POLARITY & TEST DISTANCE: HORIZONTAL AT 3 M

NO.	FREQ. (MHz)	EMISSION LEVEL (dBuV/m)	LIMIT (dBuV/m)	MARGIN (dB)	ANTENNA HEIGHT (m)	TABLE ANGLE (Degree)	RAW VALUE (dBuV)	CORRECTION FACTOR (dB/m)
1	*5320.00	103.1 PK			1.89 H	263	94.61	8.52
2	*5320.00	92.2 AV			1.89 H	263	83.63	8.52
3	5350.00	56.5 PK	68.2	-11.7	1.94 H	258	47.92	8.57
4	10640.00	51.5 PK	74.0	-22.5	1.50 H	184	31.85	19.62
5	10640.00	43.0 AV	54.0	-11.0	1.50 H	184	23.33	19.62
6	15960.00	60.3 PK	74.0	-13.7	1.87 H	270	37.88	22.44
7	15960.00	47.5 AV	54.0	-6.5	1.87 H	270	25.07	22.44

ANTENNA POLARITY & TEST DISTANCE: VERTICAL AT 3 M

NO.	FREQ. (MHz)	EMISSION LEVEL (dBuV/m)	LIMIT (dBuV/m)	MARGIN (dB)	ANTENNA HEIGHT (m)	TABLE ANGLE (Degree)	RAW VALUE (dBuV)	CORRECTION FACTOR (dB/m)
1	*5320.00	100.1 PK			1.15 V	278	91.57	8.52
2	*5320.00	89.4 AV			1.15 V	278	80.85	8.52
3	5350.00	52.8 PK	68.2	-15.4	1.15 V	278	44.24	8.57
4	10640.00	52.1 PK	74.0	-21.9	1.59 V	234	32.52	19.62
5	10640.00	41.9 AV	54.0	-12.1	1.59 V	234	22.26	19.62
6	15960.00	58.5 PK	74.0	-15.5	1.48 V	274	36.02	22.44
7	15960.00	46.5 AV	54.0	-7.5	1.48 V	274	24.08	22.44

REMARKS:

1. Emission level (dBuV/m) = Raw Value (dBuV) + Correction Factor (dB/m).
2. Correction Factor (dB/m) = Antenna Factor (dB/m) + Cable Factor (dB).
3. The other emission levels were very low against the limit.
4. Margin value = Emission level – Limit value.
5. " \* ": Fundamental frequency.



802.11n (40MHz)

CHANNEL	TX Channel 54	DETECTOR FUNCTION	Peak (PK)
FREQUENCY RANGE	1GHz ~ 40GHz		Average (AV)

ANTENNA POLARITY & TEST DISTANCE: HORIZONTAL AT 3 M

NO.	FREQ. (MHz)	EMISSION LEVEL (dBuV/m)	LIMIT (dBuV/m)	MARGIN (dB)	ANTENNA HEIGHT (m)	TABLE ANGLE (Degree)	RAW VALUE (dBuV)	CORRECTION FACTOR (dB/m)
1	*5270.00	100.6 PK			1.87 H	263	92.14	8.45
2	*5270.00	88.2 AV			1.87 H	263	79.78	8.45
3	#10540.00	51.5 PK	74.0	-22.5	1.92 H	271	31.91	19.57
4	#10540.00	43.0 AV	54.0	-11.0	1.92 H	271	23.39	19.57
5	15810.00	59.6 PK	74.0	-14.4	1.62 H	221	37.55	22.09
6	15810.00	47.6 AV	54.0	-6.4	1.62 H	221	25.51	22.09

ANTENNA POLARITY & TEST DISTANCE: VERTICAL AT 3 M

NO.	FREQ. (MHz)	EMISSION LEVEL (dBuV/m)	LIMIT (dBuV/m)	MARGIN (dB)	ANTENNA HEIGHT (m)	TABLE ANGLE (Degree)	RAW VALUE (dBuV)	CORRECTION FACTOR (dB/m)
1	*5270.00	98.0 PK			1.96 V	254	89.54	8.45
2	*5270.00	85.5 AV			1.96 V	254	77.03	8.45
3	#10540.00	51.6 PK	74.0	-22.4	2.14 V	260	32.07	19.57
4	#10540.00	42.5 AV	54.0	-11.5	2.14 V	260	22.93	19.57
5	15810.00	60.5 PK	74.0	-13.5	1.96 V	263	38.42	22.09
6	15810.00	47.6 AV	54.0	-6.4	1.96 V	263	25.53	22.09

REMARKS:

1. Emission level (dBuV/m) = Raw Value (dBuV) + Correction Factor (dB/m).
2. Correction Factor (dB/m) = Antenna Factor (dB/m) + Cable Factor (dB).
3. The other emission levels were very low against the limit.
4. Margin value = Emission level – Limit value.
5. " \* ": Fundamental frequency.
6. " # ": The radiated frequency is out of the restricted band.



<b>CHANNEL</b>	TX Channel 62	<b>DETECTOR FUNCTION</b>	Peak (PK)
<b>FREQUENCY RANGE</b>	1GHz ~ 40GHz		Average (AV)

**ANTENNA POLARITY & TEST DISTANCE: HORIZONTAL AT 3 M**

NO.	FREQ. (MHz)	EMISSION LEVEL (dBuV/m)	LIMIT (dBuV/m)	MARGIN (dB)	ANTENNA HEIGHT (m)	TABLE ANGLE (Degree)	RAW VALUE (dBuV)	CORRECTION FACTOR (dB/m)
1	*5310.00	100.1 PK			1.95 H	87	91.62	8.51
2	*5310.00	87.8 AV			1.95 H	87	79.27	8.51
3	5350.00	63.9 PK	68.2	-4.3	1.95 H	87	55.28	8.57
4	10620.00	58.4 PK	74.0	-15.6	2.00 H	133	38.80	19.61
5	10620.00	47.0 AV	54.0	-7.0	2.00 H	133	27.38	19.61
6	15930.00	62.6 PK	74.0	-11.4	1.47 H	148	40.18	22.37
7	15930.00	47.6 AV	54.0	-6.4	1.47 H	148	25.21	22.37

**ANTENNA POLARITY & TEST DISTANCE: VERTICAL AT 3 M**

NO.	FREQ. (MHz)	EMISSION LEVEL (dBuV/m)	LIMIT (dBuV/m)	MARGIN (dB)	ANTENNA HEIGHT (m)	TABLE ANGLE (Degree)	RAW VALUE (dBuV)	CORRECTION FACTOR (dB/m)
1	*5310.00	98.3 PK			1.84 V	238	89.77	8.51
2	*5310.00	86.2 AV			1.84 V	238	77.65	8.51
3	5350.00	62.9 PK	68.2	-5.3	1.84 V	238	54.34	8.57
4	10620.00	52.8 PK	74.0	-21.2	1.00 V	306	33.16	19.61
5	10620.00	42.0 AV	54.0	-12.0	1.00 V	306	22.34	19.61
6	15930.00	59.4 PK	74.0	-14.6	1.49 V	263	37.05	22.37
7	15930.00	46.8 AV	54.0	-7.2	1.49 V	263	24.44	22.37

**REMARKS:**

1. Emission level (dBuV/m) = Raw Value (dBuV) + Correction Factor (dB/m).
2. Correction Factor (dB/m) = Antenna Factor (dB/m) + Cable Factor (dB).
3. The other emission levels were very low against the limit.
4. Margin value = Emission level – Limit value.
5. " \* ": Fundamental frequency.



802.11ac 80MHz

<b>CHANNEL</b>	TX Channel 58	<b>DETECTOR FUNCTION</b>	Peak (PK)
<b>FREQUENCY RANGE</b>	1GHz ~ 40GHz		Average (AV)

ANTENNA POLARITY & TEST DISTANCE: HORIZONTAL AT 3 M								
NO.	FREQ. (MHz)	EMISSION LEVEL (dBuV/m)	LIMIT (dBuV/m)	MARGIN (dB)	ANTENNA HEIGHT (m)	TABLE ANGLE (Degree)	RAW VALUE (dBuV)	CORRECTION FACTOR (dB/m)
1	*5290.00	97.1 PK			1.56 H	203	88.58	8.49
2	*5290.00	83.6 AV			1.56 H	203	75.10	8.49
3	5350.00	65.5 PK	68.2	-2.7	1.56 H	203	56.92	8.57
4	#10580.00	52.5 PK	74.0	-21.5	2.16 H	265	32.89	19.59
5	#10580.00	41.0 AV	54.0	-13.0	2.16 H	265	21.41	19.59
6	15870.00	60.5 PK	74.0	-13.5	1.74 H	296	38.29	22.23
7	15870.00	47.3 AV	54.0	-6.7	1.74 H	296	25.02	22.23

ANTENNA POLARITY & TEST DISTANCE: VERTICAL AT 3 M								
NO.	FREQ. (MHz)	EMISSION LEVEL (dBuV/m)	LIMIT (dBuV/m)	MARGIN (dB)	ANTENNA HEIGHT (m)	TABLE ANGLE (Degree)	RAW VALUE (dBuV)	CORRECTION FACTOR (dB/m)
1	*5290.00	94.4 PK			1.63 V	243	85.91	8.49
2	*5290.00	81.6 AV			1.63 V	243	73.13	8.49
3	5350.00	63.8 PK	68.2	-4.4	1.63 V	243	55.22	8.57
4	#10580.00	52.7 PK	74.0	-21.3	1.84 V	263	33.15	19.59
5	#10580.00	42.0 AV	54.0	-12.0	1.84 V	263	22.36	19.59
6	15870.00	58.6 PK	74.0	-15.4	2.00 V	184	36.41	22.23
7	15870.00	46.6 AV	54.0	-7.4	2.00 V	184	24.39	22.23

REMARKS:

1. Emission level (dBuV/m) = Raw Value (dBuV) + Correction Factor (dB/m).
2. Correction Factor (dB/m) = Antenna Factor (dB/m) + Cable Factor (dB).
3. The other emission levels were very low against the limit.
4. Margin value = Emission level – Limit value.
5. " \* ": Fundamental frequency.
6. " # ": The radiated frequency is out of the restricted band.



Band 3 (5470-5725MHz):

ABOVE 1GHz DATA

802.11a

CHANNEL	TX Channel 100	DETECTOR FUNCTION	Peak (PK)
FREQUENCY RANGE	1GHz ~ 40GHz		Average (AV)

ANTENNA POLARITY & TEST DISTANCE: HORIZONTAL AT 3 M

NO.	FREQ. (MHz)	EMISSION LEVEL (dBuV/m)	LIMIT (dBuV/m)	MARGIN (dB)	ANTENNA HEIGHT (m)	TABLE ANGLE (Degree)	RAW VALUE (dBuV)	CORRECTION FACTOR (dB/m)
1	5460.00	50.5 PK	74.0	-23.5	1.50 H	0	41.80	8.74
2	5460.00	38.9 AV	54.0	-15.1	1.50 H	0	30.12	8.74
3	#5470.00	56.1 PK	68.2	-12.1	1.50 H	0	47.30	8.75
4	*5500.00	102.6 PK			1.50 H	0	93.82	8.80
5	*5500.00	91.2 AV			1.50 H	0	82.35	8.80
6	11000.00	52.6 PK	74.0	-21.4	1.94 H	78	32.80	19.80
7	11000.00	41.7 AV	54.0	-12.3	1.94 H	78	21.87	19.80
8	#16500.00	59.3 PK	74.0	-14.7	1.98 H	230	37.75	21.57
9	#16500.00	46.3 AV	54.0	-7.7	1.98 H	230	24.68	21.57

ANTENNA POLARITY & TEST DISTANCE: VERTICAL AT 3 M

NO.	FREQ. (MHz)	EMISSION LEVEL (dBuV/m)	LIMIT (dBuV/m)	MARGIN (dB)	ANTENNA HEIGHT (m)	TABLE ANGLE (Degree)	RAW VALUE (dBuV)	CORRECTION FACTOR (dB/m)
1	5460.00	50.4 PK	74.0	-23.6	1.56 V	285	41.70	8.74
2	5460.00	39.3 AV	54.0	-14.7	1.56 V	285	30.58	8.74
3	#5470.00	57.8 PK	68.2	-10.4	1.56 V	285	49.06	8.75
4	*5500.00	102.7 PK			1.56 V	285	93.88	8.80
5	*5500.00	92.1 AV			1.56 V	285	83.26	8.80
6	11000.00	53.1 PK	74.0	-20.9	1.63 V	281	33.34	19.80
7	11000.00	43.6 AV	54.0	-10.4	1.63 V	281	23.82	19.80
8	#16500.00	60.3 PK	74.0	-13.7	1.95 V	284	38.75	21.57
9	#16500.00	46.9 AV	54.0	-7.1	1.95 V	284	25.32	21.57

REMARKS:

1. Emission level (dBuV/m) = Raw Value (dBuV) + Correction Factor (dB/m).
2. Correction Factor (dB/m) = Antenna Factor (dB/m) + Cable Factor (dB).
3. The other emission levels were very low against the limit.
4. Margin value = Emission level – Limit value.
5. " \* ": Fundamental frequency.
6. " # ": The radiated frequency is out of the restricted band.



CHANNEL	TX Channel 116	DETECTOR FUNCTION	Peak (PK)
FREQUENCY RANGE	1GHz ~ 40GHz		Average (AV)

ANTENNA POLARITY & TEST DISTANCE: HORIZONTAL AT 3 M

NO.	FREQ. (MHz)	EMISSION LEVEL (dBuV/m)	LIMIT (dBuV/m)	MARGIN (dB)	ANTENNA HEIGHT (m)	TABLE ANGLE (Degree)	RAW VALUE (dBuV)	CORRECTION FACTOR (dB/m)
1	*5580.00	105.8 PK			2.10 H	167	96.54	9.21
2	*5580.00	94.6 AV			2.10 H	167	85.35	9.21
3	11160.00	53.9 PK	74.0	-20.1	1.54 H	255	34.63	19.27
4	11160.00	41.6 AV	54.0	-12.4	1.54 H	255	22.31	19.27
5	#16740.00	59.8 PK	74.0	-14.2	1.94 H	282	37.25	22.57
6	#16740.00	47.6 AV	54.0	-6.4	1.94 H	282	25.06	22.57

ANTENNA POLARITY & TEST DISTANCE: VERTICAL AT 3 M

NO.	FREQ. (MHz)	EMISSION LEVEL (dBuV/m)	LIMIT (dBuV/m)	MARGIN (dB)	ANTENNA HEIGHT (m)	TABLE ANGLE (Degree)	RAW VALUE (dBuV)	CORRECTION FACTOR (dB/m)
1	*5580.00	99.2 PK			1.65 V	132	90.03	9.21
2	*5580.00	87.7 AV			1.65 V	132	78.47	9.21
3	11160.00	54.6 PK	74.0	-19.4	1.84 V	95	35.35	19.27
4	11160.00	42.3 AV	54.0	-11.7	1.84 V	95	23.03	19.27
5	#16740.00	58.4 PK	74.0	-15.6	1.84 V	221	35.85	22.57
6	#16740.00	48.0 AV	54.0	-6.0	1.84 V	221	25.41	22.57

REMARKS:

1. Emission level (dBuV/m) = Raw Value (dBuV) + Correction Factor (dB/m).
2. Correction Factor (dB/m) = Antenna Factor (dB/m) + Cable Factor (dB).
3. The other emission levels were very low against the limit.
4. Margin value = Emission level – Limit value.
5. " \* ": Fundamental frequency.
6. " # ": The radiated frequency is out of the restricted band.



<b>CHANNEL</b>	TX Channel 140	<b>DETECTOR FUNCTION</b>	Peak (PK)
<b>FREQUENCY RANGE</b>	1GHz ~ 40GHz		Average (AV)

**ANTENNA POLARITY & TEST DISTANCE: HORIZONTAL AT 3 M**

NO.	FREQ. (MHz)	EMISSION LEVEL (dBuV/m)	LIMIT (dBuV/m)	MARGIN (dB)	ANTENNA HEIGHT (m)	TABLE ANGLE (Degree)	RAW VALUE (dBuV)	CORRECTION FACTOR (dB/m)
1	*5700.00	106.8 PK			1.85 H	263	96.97	9.83
2	*5700.00	95.5 AV			1.85 H	263	85.64	9.83
3	#5725.00	58.1 PK	68.2	-10.1	1.85 H	263	48.13	9.96
4	11400.00	52.8 PK	74.0	-21.2	2.41 H	195	34.36	18.48
5	11400.00	41.7 AV	54.0	-12.3	2.41 H	195	23.17	18.48
6	#17100.00	58.4 PK	74.0	-15.6	1.49 H	235	34.64	23.78
7	#17100.00	47.4 AV	54.0	-6.6	1.49 H	235	23.58	23.78

**ANTENNA POLARITY & TEST DISTANCE: VERTICAL AT 3 M**

NO.	FREQ. (MHz)	EMISSION LEVEL (dBuV/m)	LIMIT (dBuV/m)	MARGIN (dB)	ANTENNA HEIGHT (m)	TABLE ANGLE (Degree)	RAW VALUE (dBuV)	CORRECTION FACTOR (dB/m)
1	*5700.00	98.9 PK			1.26 V	247	89.10	9.83
2	*5700.00	87.9 AV			1.26 V	247	78.05	9.83
3	#5725.00	53.4 PK	68.2	-14.8	1.26 V	247	43.46	9.96
4	11400.00	52.1 PK	74.0	-21.9	1.96 V	235	33.66	18.48
5	11400.00	42.0 AV	54.0	-12.0	1.96 V	235	23.48	18.48
6	#17100.00	59.6 PK	74.0	-14.4	1.57 V	234	35.84	23.78
7	#17100.00	47.7 AV	54.0	-6.3	1.57 V	234	23.87	23.78

**REMARKS:**

1. Emission level (dBuV/m) = Raw Value (dBuV) + Correction Factor (dB/m).
2. Correction Factor (dB/m) = Antenna Factor (dB/m) + Cable Factor (dB).
3. The other emission levels were very low against the limit.
4. Margin value = Emission level – Limit value.
5. " \* ": Fundamental frequency.
6. " # ": The radiated frequency is out of the restricted band.



802.11n (20MHz)

<b>CHANNEL</b>	TX Channel 100	<b>DETECTOR FUNCTION</b>	Peak (PK)
<b>FREQUENCY RANGE</b>	1GHz ~ 40GHz		Average (AV)

**ANTENNA POLARITY & TEST DISTANCE: HORIZONTAL AT 3 M**

NO.	FREQ. (MHz)	EMISSION LEVEL (dBuV/m)	LIMIT (dBuV/m)	MARGIN (dB)	ANTENNA HEIGHT (m)	TABLE ANGLE (Degree)	RAW VALUE (dBuV)	CORRECTION FACTOR (dB/m)
1	5460.00	49.7 PK	74.0	-24.3	1.86 H	293	40.96	8.74
2	5460.00	38.1 AV	54.0	-15.9	1.86 H	293	29.37	8.74
3	#5470.00	54.4 PK	68.2	-13.8	1.86 H	293	45.67	8.75
4	*5500.00	101.5 PK			1.86 H	293	92.71	8.80
5	*5500.00	89.9 AV			1.86 H	293	81.11	8.80
6	11000.00	52.3 PK	74.0	-21.7	1.65 H	289	32.53	19.80
7	11000.00	42.2 AV	54.0	-11.8	1.65 H	289	22.36	19.80
8	#16500.00	60.3 PK	74.0	-13.7	1.75 H	296	38.75	21.57
9	#16500.00	48.6 AV	54.0	-5.4	1.75 H	296	27.05	21.57

**ANTENNA POLARITY & TEST DISTANCE: VERTICAL AT 3 M**

NO.	FREQ. (MHz)	EMISSION LEVEL (dBuV/m)	LIMIT (dBuV/m)	MARGIN (dB)	ANTENNA HEIGHT (m)	TABLE ANGLE (Degree)	RAW VALUE (dBuV)	CORRECTION FACTOR (dB/m)
1	5460.00	49.8 PK	74.0	-24.2	1.68 V	325	41.10	8.74
2	5460.00	38.2 AV	54.0	-15.8	1.68 V	325	29.49	8.74
3	#5470.00	53.9 PK	68.2	-14.3	1.68 V	325	45.15	8.75
4	*5500.00	102.1 PK			1.68 V	325	93.29	8.80
5	*5500.00	90.7 AV			1.68 V	325	81.87	8.80
6	11000.00	51.7 PK	74.0	-22.3	1.54 V	223	31.88	19.80
7	11000.00	40.3 AV	54.0	-13.7	1.54 V	223	20.50	19.80
8	#16500.00	58.4 PK	74.0	-15.6	1.60 V	285	36.84	21.57
9	#16500.00	46.9 AV	54.0	-7.1	1.60 V	285	25.33	21.57

**REMARKS:**

1. Emission level (dBuV/m) = Raw Value (dBuV) + Correction Factor (dB/m).
2. Correction Factor (dB/m) = Antenna Factor (dB/m) + Cable Factor (dB).
3. The other emission levels were very low against the limit.
4. Margin value = Emission level – Limit value.
5. " \* ": Fundamental frequency.
6. " # ": The radiated frequency is out of the restricted band.



CHANNEL	TX Channel 116	DETECTOR FUNCTION	Peak (PK)
FREQUENCY RANGE	1GHz ~ 40GHz		Average (AV)

ANTENNA POLARITY & TEST DISTANCE: HORIZONTAL AT 3 M

NO.	FREQ. (MHz)	EMISSION LEVEL (dBuV/m)	LIMIT (dBuV/m)	MARGIN (dB)	ANTENNA HEIGHT (m)	TABLE ANGLE (Degree)	RAW VALUE (dBuV)	CORRECTION FACTOR (dB/m)
1	*5580.00	103.2 PK			1.98 H	186	94.02	9.21
2	*5580.00	92.3 AV			1.98 H	186	83.04	9.21
3	11160.00	52.2 PK	74.0	-21.8	1.54 H	205	32.94	19.27
4	11160.00	42.6 AV	54.0	-11.4	1.54 H	205	23.32	19.27
5	#16740.00	60.6 PK	74.0	-13.4	1.77 H	321	38.01	22.57
6	#16740.00	47.3 AV	54.0	-6.7	1.77 H	321	24.75	22.57

ANTENNA POLARITY & TEST DISTANCE: VERTICAL AT 3 M

NO.	FREQ. (MHz)	EMISSION LEVEL (dBuV/m)	LIMIT (dBuV/m)	MARGIN (dB)	ANTENNA HEIGHT (m)	TABLE ANGLE (Degree)	RAW VALUE (dBuV)	CORRECTION FACTOR (dB/m)
1	*5580.00	98.0 PK			1.69 V	247	88.83	9.21
2	*5580.00	87.2 AV			1.69 V	247	77.96	9.21
3	11160.00	51.7 PK	74.0	-22.3	1.54 V	148	32.38	19.27
4	11160.00	42.5 AV	54.0	-11.5	1.54 V	148	23.24	19.27
5	#16740.00	59.5 PK	74.0	-14.5	1.98 V	201	36.90	22.57
6	#16740.00	46.9 AV	54.0	-7.1	1.98 V	201	24.30	22.57

REMARKS:

1. Emission level (dBuV/m) = Raw Value (dBuV) + Correction Factor (dB/m).
2. Correction Factor (dB/m) = Antenna Factor (dB/m) + Cable Factor (dB).
3. The other emission levels were very low against the limit.
4. Margin value = Emission level – Limit value.
5. " \* ": Fundamental frequency.
6. " # ": The radiated frequency is out of the restricted band.



<b>CHANNEL</b>	TX Channel 140	<b>DETECTOR FUNCTION</b>	Peak (PK)
<b>FREQUENCY RANGE</b>	1GHz ~ 40GHz		Average (AV)

ANTENNA POLARITY & TEST DISTANCE: HORIZONTAL AT 3 M								
NO.	FREQ. (MHz)	EMISSION LEVEL (dBuV/m)	LIMIT (dBuV/m)	MARGIN (dB)	ANTENNA HEIGHT (m)	TABLE ANGLE (Degree)	RAW VALUE (dBuV)	CORRECTION FACTOR (dB/m)
1	*5700.00	106.0 PK			1.88 H	263	96.12	9.83
2	*5700.00	94.4 AV			1.88 H	263	84.58	9.83
3	#5725.00	57.6 PK	68.2	-10.6	1.88 H	263	47.67	9.96
4	11400.00	52.8 PK	74.0	-21.2	1.96 H	248	34.33	18.48
5	11400.00	42.0 AV	54.0	-12.0	1.96 H	248	23.47	18.48
6	#17100.00	58.5 PK	74.0	-15.5	1.85 H	230	34.69	23.78
7	#17100.00	46.2 AV	54.0	-7.8	1.85 H	230	22.44	23.78
ANTENNA POLARITY & TEST DISTANCE: VERTICAL AT 3 M								
NO.	FREQ. (MHz)	EMISSION LEVEL (dBuV/m)	LIMIT (dBuV/m)	MARGIN (dB)	ANTENNA HEIGHT (m)	TABLE ANGLE (Degree)	RAW VALUE (dBuV)	CORRECTION FACTOR (dB/m)
1	*5700.00	99.7 PK			1.80 V	78	89.88	9.83
2	*5700.00	88.7 AV			1.80 V	78	78.83	9.83
3	#5725.00	54.0 PK	68.2	-14.2	1.80 V	78	44.05	9.96
4	11400.00	51.5 PK	74.0	-22.5	1.85 V	236	33.00	18.48
5	11400.00	42.7 AV	54.0	-11.3	1.85 V	236	24.17	18.48
6	#17100.00	59.4 PK	74.0	-14.6	2.05 V	165	35.62	23.78
7	#17100.00	48.3 AV	54.0	-5.7	2.05 V	165	24.54	23.78

**REMARKS:**

1. Emission level (dBuV/m) = Raw Value (dBuV) + Correction Factor (dB/m).
2. Correction Factor (dB/m) = Antenna Factor (dB/m) + Cable Factor (dB).
3. The other emission levels were very low against the limit.
4. Margin value = Emission level – Limit value.
5. " \* ": Fundamental frequency.
6. " # ": The radiated frequency is out of the restricted band.

**802.11n (40MHz)**

<b>CHANNEL</b>	TX Channel 102	<b>DETECTOR FUNCTION</b>	Peak (PK)
<b>FREQUENCY RANGE</b>	1GHz ~ 40GHz		Average (AV)

<b>ANTENNA POLARITY &amp; TEST DISTANCE: HORIZONTAL AT 3 M</b>								
NO.	FREQ. (MHz)	EMISSION LEVEL (dBuV/m)	LIMIT (dBuV/m)	MARGIN (dB)	ANTENNA HEIGHT (m)	TABLE ANGLE (Degree)	RAW VALUE (dBuV)	CORRECTION FACTOR (dB/m)
1	5460.00	55.1 PK	74.0	-18.9	1.25 H	301	46.36	8.74
2	5460.00	42.0 AV	54.0	-12.0	1.25 H	301	33.21	8.74
3	#5470.00	61.3 PK	68.2	-6.9	1.25 H	301	52.50	8.75
4	*5510.00	98.7 PK			1.25 H	301	89.80	8.85
5	*5510.00	87.0 AV			1.25 H	301	78.17	8.85
6	11020.00	54.8 PK	74.0	-19.2	1.09 H	235	35.06	19.74
7	11020.00	43.2 AV	54.0	-10.8	1.09 H	235	23.41	19.74
8	#16530.00	58.7 PK	74.0	-15.3	1.85 H	89	37.03	21.69
9	#16530.00	47.3 AV	54.0	-6.7	1.85 H	89	25.61	21.69
<b>ANTENNA POLARITY &amp; TEST DISTANCE: VERTICAL AT 3 M</b>								
NO.	FREQ. (MHz)	EMISSION LEVEL (dBuV/m)	LIMIT (dBuV/m)	MARGIN (dB)	ANTENNA HEIGHT (m)	TABLE ANGLE (Degree)	RAW VALUE (dBuV)	CORRECTION FACTOR (dB/m)
1	5460.00	55.7 PK	74.0	-18.3	1.00 V	0	47.00	8.74
2	5460.00	41.4 AV	54.0	-12.6	1.00 V	0	32.67	8.74
3	#5470.00	59.5 PK	68.2	-8.7	1.00 V	0	50.76	8.75
4	*5510.00	99.2 PK			1.00 V	0	90.31	8.85
5	*5510.00	87.2 AV			1.00 V	0	78.33	8.85
6	11020.00	51.3 PK	74.0	-22.7	1.59 V	216	31.52	19.74
7	11020.00	42.5 AV	54.0	-11.5	1.59 V	216	22.77	19.74
8	#16530.00	59.3 PK	74.0	-14.7	1.84 V	276	37.61	21.69
9	#16530.00	48.2 AV	54.0	-5.8	1.84 V	276	26.51	21.69

**REMARKS:**

1. Emission level (dBuV/m) = Raw Value (dBuV) + Correction Factor (dB/m).
2. Correction Factor (dB/m) = Antenna Factor (dB/m) + Cable Factor (dB).
3. The other emission levels were very low against the limit.
4. Margin value = Emission level – Limit value.
5. " \* ": Fundamental frequency.
6. " # ": The radiated frequency is out of the restricted band.



<b>CHANNEL</b>	TX Channel 110	<b>DETECTOR FUNCTION</b>	Peak (PK)
<b>FREQUENCY RANGE</b>	1GHz ~ 40GHz		Average (AV)

<b>ANTENNA POLARITY &amp; TEST DISTANCE: HORIZONTAL AT 3 M</b>								
NO.	FREQ. (MHz)	EMISSION LEVEL (dBuV/m)	LIMIT (dBuV/m)	MARGIN (dB)	ANTENNA HEIGHT (m)	TABLE ANGLE (Degree)	RAW VALUE (dBuV)	CORRECTION FACTOR (dB/m)
1	*5550.00	102.1 PK			1.16 H	258	92.78	9.27
2	*5550.00	89.5 AV			1.16 H	258	80.25	9.27
3	11100.00	52.1 PK	74.0	-21.9	1.59 H	276	32.93	19.21
4	11100.00	42.4 AV	54.0	-11.6	1.59 H	276	23.15	19.21
5	#16650.00	58.6 PK	74.0	-15.4	1.93 H	185	35.86	22.69
6	#16650.00	46.4 AV	54.0	-7.6	1.93 H	185	23.68	22.69
<b>ANTENNA POLARITY &amp; TEST DISTANCE: VERTICAL AT 3 M</b>								
NO.	FREQ. (MHz)	EMISSION LEVEL (dBuV/m)	LIMIT (dBuV/m)	MARGIN (dB)	ANTENNA HEIGHT (m)	TABLE ANGLE (Degree)	RAW VALUE (dBuV)	CORRECTION FACTOR (dB/m)
1	*5550.00	99.9 PK			1.47 V	263	90.64	9.27
2	*5550.00	87.8 AV			1.47 V	263	78.48	9.27
3	11100.00	54.6 PK	74.0	-19.4	1.48 V	98	35.41	19.21
4	11100.00	41.5 AV	54.0	-12.5	1.48 V	98	22.29	19.21
5	#16650.00	59.3 PK	74.0	-14.7	1.85 V	302	36.61	22.69
6	#16650.00	47.6 AV	54.0	-6.4	1.85 V	302	24.87	22.69

**REMARKS:**

1. Emission level (dBuV/m) = Raw Value (dBuV) + Correction Factor (dB/m).
2. Correction Factor (dB/m) = Antenna Factor (dB/m) + Cable Factor (dB).
3. The other emission levels were very low against the limit.
4. Margin value = Emission level – Limit value.
5. " \* ": Fundamental frequency.
6. " # ": The radiated frequency is out of the restricted band.



<b>CHANNEL</b>	TX Channel 134	<b>DETECTOR FUNCTION</b>	Peak (PK)
<b>FREQUENCY RANGE</b>	1GHz ~ 40GHz		Average (AV)

<b>ANTENNA POLARITY &amp; TEST DISTANCE: HORIZONTAL AT 3 M</b>								
NO.	FREQ. (MHz)	EMISSION LEVEL (dBuV/m)	LIMIT (dBuV/m)	MARGIN (dB)	ANTENNA HEIGHT (m)	TABLE ANGLE (Degree)	RAW VALUE (dBuV)	CORRECTION FACTOR (dB/m)
1	*5670.00	102.7 PK			1.00 H	327	92.97	9.68
2	*5670.00	90.5 AV			1.00 H	327	80.84	9.68
3	#5725.00	58.3 PK	68.2	-9.9	1.00 H	327	48.29	9.96
4	11340.00	53.0 PK	74.0	-21.0	1.70 H	128	34.31	18.69
5	11340.00	42.3 AV	54.0	-11.7	1.70 H	128	23.61	18.69
6	#17010.00	59.3 PK	74.0	-14.7	1.85 H	263	35.68	23.66
<b>ANTENNA POLARITY &amp; TEST DISTANCE: VERTICAL AT 3 M</b>								
NO.	FREQ. (MHz)	EMISSION LEVEL (dBuV/m)	LIMIT (dBuV/m)	MARGIN (dB)	ANTENNA HEIGHT (m)	TABLE ANGLE (Degree)	RAW VALUE (dBuV)	CORRECTION FACTOR (dB/m)
1	*5670.00	95.9 PK			1.95 V	230	86.18	9.68
2	*5670.00	84.5 AV			1.95 V	230	74.85	9.68
3	#5725.00	54.2 PK	68.2	-14.0	1.95 V	230	44.28	9.96
4	11340.00	51.9 PK	74.0	-22.2	1.85 V	326	33.16	18.69
5	11340.00	41.9 AV	54.0	-12.1	1.85 V	326	23.21	18.69
6	#17010.00	60.3 PK	74.0	-13.7	1.93 V	224	36.65	23.66

**REMARKS:**

1. Emission level (dBuV/m) = Raw Value (dBuV) + Correction Factor (dB/m).
2. Correction Factor (dB/m) = Antenna Factor (dB/m) + Cable Factor (dB).
3. The other emission levels were very low against the limit.
4. Margin value = Emission level – Limit value.
5. " \* ": Fundamental frequency.
6. " # ": The radiated frequency is out of the restricted band.



802.11ac 80MHz

CHANNEL	TX Channel 106	DETECTOR FUNCTION	Peak (PK)
FREQUENCY RANGE	1GHz ~ 40GHz		Average (AV)

ANTENNA POLARITY & TEST DISTANCE: HORIZONTAL AT 3 M								
NO.	FREQ. (MHz)	EMISSION LEVEL (dBuV/m)	LIMIT (dBuV/m)	MARGIN (dB)	ANTENNA HEIGHT (m)	TABLE ANGLE (Degree)	RAW VALUE (dBuV)	CORRECTION FACTOR (dB/m)
1	*5670.00	102.7 PK			1.00 H	327	92.97	9.68
2	*5670.00	90.5 AV			1.00 H	327	80.84	9.68
3	#5725.00	58.3 PK	68.2	-9.9	1.00 H	327	48.29	9.96
4	11340.00	53.0 PK	74.0	-21.0	1.70 H	128	34.31	18.69
5	11340.00	42.3 AV	54.0	-11.7	1.70 H	128	23.61	18.69
6	#17010.00	59.3 PK	74.0	-14.7	1.85 H	263	35.68	23.66
7	#17010.00	47.6 AV	54.0	-6.4	1.85 H	263	23.95	23.66
ANTENNA POLARITY & TEST DISTANCE: VERTICAL AT 3 M								
NO.	FREQ. (MHz)	EMISSION LEVEL (dBuV/m)	LIMIT (dBuV/m)	MARGIN (dB)	ANTENNA HEIGHT (m)	TABLE ANGLE (Degree)	RAW VALUE (dBuV)	CORRECTION FACTOR (dB/m)
1	*5670.00	95.9 PK			1.95 V	230	86.18	9.68
2	*5670.00	84.5 AV			1.95 V	230	74.85	9.68
3	#5725.00	54.2 PK	68.2	-14.0	1.95 V	230	44.28	9.96
4	11340.00	51.9 PK	74.0	-22.1	1.85 V	326	33.16	18.69
5	11340.00	41.9 AV	54.0	-12.1	1.85 V	326	23.21	18.69
6	#17010.00	60.3 PK	74.0	-13.7	1.93 V	224	36.65	23.66
7	#17010.00	47.8 AV	54.0	-6.2	1.93 V	224	24.14	23.66

REMARKS:

1. Emission level (dBuV/m) = Raw Value (dBuV) + Correction Factor (dB/m).
2. Correction Factor (dB/m) = Antenna Factor (dB/m) + Cable Factor (dB).
3. The other emission levels were very low against the limit.
4. Margin value = Emission level – Limit value.
5. " \* ": Fundamental frequency.
6. " # ": The radiated frequency is out of the restricted band.

**Band 4 (5725-5850MHz):****ABOVE 1GHz DATA****802.11a**

<b>CHANNEL</b>	TX Channel 149	<b>DETECTOR FUNCTION</b>	Peak (PK)
<b>FREQUENCY RANGE</b>	1GHz ~ 40GHz		Average (AV)

<b>ANTENNA POLARITY &amp; TEST DISTANCE: HORIZONTAL AT 3 M</b>								
<b>NO.</b>	<b>FREQ. (MHz)</b>	<b>EMISSION LEVEL (dBuV/m)</b>	<b>LIMIT (dBuV/m)</b>	<b>MARGIN (dB)</b>	<b>ANTENNA HEIGHT (m)</b>	<b>TABLE ANGLE (Degree)</b>	<b>RAW VALUE (dBuV)</b>	<b>CORRECTION FACTOR (dB/m)</b>
1	5715.00	58.6 PK	68.2	-9.6	1.56 H	273	48.69	9.91
2	5725.00	74.8 PK	78.2	-3.4	1.56 H	273	64.89	9.91
3	*5745.00	100.8 PK			1.56 H	273	90.73	10.06
4	*5745.00	89.2 AV			1.56 H	273	79.09	10.06
5	11490.00	53.1 PK	74.0	-21.1	1.85 H	236	34.86	18.19
6	11490.00	39.3 AV	54.0	-14.7	1.85 H	236	21.06	18.19
7	#17235.00	60.8 PK	74.0	-13.2	1.50 H	254	36.81	23.96
8	#17235.00	47.7 AV	54.0	-6.3	1.50 H	254	23.69	23.96
<b>ANTENNA POLARITY &amp; TEST DISTANCE: VERTICAL AT 3 M</b>								
<b>NO.</b>	<b>FREQ. (MHz)</b>	<b>EMISSION LEVEL (dBuV/m)</b>	<b>LIMIT (dBuV/m)</b>	<b>MARGIN (dB)</b>	<b>ANTENNA HEIGHT (m)</b>	<b>TABLE ANGLE (Degree)</b>	<b>RAW VALUE (dBuV)</b>	<b>CORRECTION FACTOR (dB/m)</b>
1	5715.00	46.3 PK	68.2	-21.9	1.00 V	231	36.39	9.91
2	5725.00	62.8 PK	78.2	-15.4	1.00 V	231	52.89	9.91
3	*5745.00	97.4 PK			1.00 V	231	87.34	10.06
4	*5745.00	85.9 AV			1.00 V	231	75.84	10.06
5	11490.00	53.6 PK	74.0	-20.4	1.14 V	230	35.41	18.19
6	11490.00	39.1 AV	54.0	-15.1	1.14 V	230	20.91	18.19
7	#17235.00	60.4 PK	74.0	-13.6	1.64 V	208	36.44	23.96
8	#17235.00	48.7 AV	54.0	-5.3	1.64 V	208	24.74	23.96

**REMARKS:**

1. Emission level (dBuV/m) = Raw Value (dBuV) + Correction Factor (dB/m).
2. Correction Factor (dB/m) = Antenna Factor (dB/m) + Cable Factor (dB).
3. The other emission levels were very low against the limit.
4. Margin value = Emission level – Limit value.
5. " \* ": Fundamental frequency.
6. " # ": The radiated frequency is out of the restricted band.



<b>CHANNEL</b>	TX Channel 157	<b>DETECTOR FUNCTION</b>	Peak (PK)
<b>FREQUENCY RANGE</b>	1GHz ~ 40GHz		Average (AV)

**ANTENNA POLARITY & TEST DISTANCE: HORIZONTAL AT 3 M**

NO.	FREQ. (MHz)	EMISSION LEVEL (dBuV/m)	LIMIT (dBuV/m)	MARGIN (dB)	ANTENNA HEIGHT (m)	TABLE ANGLE (Degree)	RAW VALUE (dBuV)	CORRECTION FACTOR (dB/m)
1	*5785.00	102.6 PK			2.05 H	324	92.28	10.27
2	*5785.00	90.8 AV			2.05 H	324	80.52	10.27
3	11570.00	54.0 PK	74.0	-20.0	1.96 H	230	35.71	18.25
4	11570.00	39.5 AV	54.0	-14.5	1.96 H	230	21.28	18.25
5	#17355.00	60.2 PK	74.0	-13.8	1.85 H	264	36.11	24.12
6	#17355.00	48.0 AV	54.0	-6.0	1.85 H	264	23.89	24.12

**ANTENNA POLARITY & TEST DISTANCE: VERTICAL AT 3 M**

NO.	FREQ. (MHz)	EMISSION LEVEL (dBuV/m)	LIMIT (dBuV/m)	MARGIN (dB)	ANTENNA HEIGHT (m)	TABLE ANGLE (Degree)	RAW VALUE (dBuV)	CORRECTION FACTOR (dB/m)
1	*5785.00	99.9 PK			2.36 V	102	89.60	10.27
2	*5785.00	87.0 AV			2.36 V	102	76.75	10.27
3	11570.00	54.5 PK	74.0	-19.5	1.74 V	301	36.24	18.25
4	11570.00	39.5 AV	54.0	-14.5	1.74 V	301	21.20	18.25
5	#17355.00	60.9 PK	74.0	-13.1	1.84 V	219	36.82	24.12
6	#17355.00	48.0 AV	54.0	-6.0	1.84 V	219	23.86	24.12

**REMARKS:**

1. Emission level (dBuV/m) = Raw Value (dBuV) + Correction Factor (dB/m).
2. Correction Factor (dB/m) = Antenna Factor (dB/m) + Cable Factor (dB).
3. The other emission levels were very low against the limit.
4. Margin value = Emission level – Limit value.
5. " \* ": Fundamental frequency.
6. " # ": The radiated frequency is out of the restricted band.



<b>CHANNEL</b>	TX Channel 165	<b>DETECTOR FUNCTION</b>	Peak (PK)
<b>FREQUENCY RANGE</b>	1GHz ~ 40GHz		Average (AV)

<b>ANTENNA POLARITY &amp; TEST DISTANCE: HORIZONTAL AT 3 M</b>								
NO.	FREQ. (MHz)	EMISSION LEVEL (dBuV/m)	LIMIT (dBuV/m)	MARGIN (dB)	ANTENNA HEIGHT (m)	TABLE ANGLE (Degree)	RAW VALUE (dBuV)	CORRECTION FACTOR (dB/m)
1	*5825.00	100.3 PK			1.74 H	203	89.82	10.48
2	*5825.00	88.9 AV			1.74 H	203	78.42	10.48
3	5850.00	54.3 PK	78.2	-23.9	1.74 H	203	43.69	10.61
4	5860.00	48.0 PK	68.2	-20.2	1.74 H	203	37.39	10.61
5	11650.00	54.8 PK	74.0	-19.2	1.54 H	237	36.45	18.35
6	11650.00	40.6 AV	54.0	-13.4	1.54 H	237	22.25	18.35
7	#17475.00	59.2 PK	74.0	-14.8	1.64 H	302	34.92	24.28
8	#17475.00	48.6 AV	54.0	-5.4	1.64 H	302	24.32	24.28
<b>ANTENNA POLARITY &amp; TEST DISTANCE: VERTICAL AT 3 M</b>								
NO.	FREQ. (MHz)	EMISSION LEVEL (dBuV/m)	LIMIT (dBuV/m)	MARGIN (dB)	ANTENNA HEIGHT (m)	TABLE ANGLE (Degree)	RAW VALUE (dBuV)	CORRECTION FACTOR (dB/m)
1	*5825.00	95.2 PK			1.95 V	325	84.72	10.48
2	*5825.00	84.7 AV			1.95 V	325	74.22	10.48
3	5850.00	48.5 PK	78.2	-29.7	1.95 V	325	37.89	10.61
4	5860.00	47.5 PK	68.2	-20.7	1.95 V	325	36.89	10.61
5	11650.00	53.5 PK	74.0	-20.5	1.58 V	360	35.15	18.35
6	11650.00	39.6 AV	54.0	-14.4	1.58 V	360	21.25	18.35
7	#17475.00	61.7 PK	74.0	-12.3	1.62 V	238	37.42	24.28
8	#17475.00	47.3 AV	54.0	-6.7	1.62 V	238	23.02	24.28

**REMARKS:**

1. Emission level (dBuV/m) = Raw Value (dBuV) + Correction Factor (dB/m).
2. Correction Factor (dB/m) = Antenna Factor (dB/m) + Cable Factor (dB).
3. The other emission levels were very low against the limit.
4. Margin value = Emission level – Limit value.
5. " \* ": Fundamental frequency.
6. " # ": The radiated frequency is out of the restricted band.



## 802.11n (20MHz)

<b>CHANNEL</b>	TX Channel 149	<b>DETECTOR FUNCTION</b>	Peak (PK)
<b>FREQUENCY RANGE</b>	1GHz ~ 40GHz		Average (AV)

ANTENNA POLARITY & TEST DISTANCE: HORIZONTAL AT 3 M								
NO.	FREQ. (MHz)	EMISSION LEVEL (dBuV/m)	LIMIT (dBuV/m)	MARGIN (dB)	ANTENNA HEIGHT (m)	TABLE ANGLE (Degree)	RAW VALUE (dBuV)	CORRECTION FACTOR (dB/m)
1	5715.00	57.5 PK	68.2	-10.7	1.95 H	230	47.59	9.91
2	5725.00	74.3 PK	78.2	-3.9	1.95 H	230	64.39	9.91
3	*5745.00	100.5 PK			1.95 H	230	90.44	10.06
4	*5745.00	89.4 AV			1.95 H	230	79.34	10.06
5	11490.00	54.6 PK	74.0	-19.4	1.95 H	263	36.41	18.19
6	11490.00	40.4 AV	54.0	-13.6	1.95 H	263	22.21	18.19
7	#17235.00	61.5 PK	74.0	-12.5	1.52 H	79	37.54	23.96
8	#17235.00	46.3 AV	54.0	-7.7	1.52 H	79	22.34	23.96
ANTENNA POLARITY & TEST DISTANCE: VERTICAL AT 3 M								
NO.	FREQ. (MHz)	EMISSION LEVEL (dBuV/m)	LIMIT (dBuV/m)	MARGIN (dB)	ANTENNA HEIGHT (m)	TABLE ANGLE (Degree)	RAW VALUE (dBuV)	CORRECTION FACTOR (dB/m)
1	5715.00	47.6 PK	68.2	-20.6	1.56 V	203	37.69	9.91
2	5725.00	61.9 PK	78.2	-16.3	1.56 V	203	51.99	9.91
3	*5745.00	92.6 PK			1.56 V	203	82.54	10.06
4	*5745.00	82.4 AV			1.56 V	203	72.34	10.06
5	11490.00	54.7 PK	74.0	-19.3	2.05 V	302	36.51	18.19
6	11490.00	39.3 AV	54.0	-14.7	2.05 V	302	21.11	18.19
7	#17235.00	61.5 PK	74.0	-12.5	1.98 V	270	37.54	23.96
8	#17235.00	47.6 AV	54.0	-6.4	1.98 V	270	23.64	23.96

**REMARKS:**

1. Emission level (dBuV/m) = Raw Value (dBuV) + Correction Factor (dB/m).
2. Correction Factor (dB/m) = Antenna Factor (dB/m) + Cable Factor (dB).
3. The other emission levels were very low against the limit.
4. Margin value = Emission level – Limit value.
5. " \* ": Fundamental frequency.
6. " # ": The radiated frequency is out of the restricted band.



CHANNEL	TX Channel 157	DETECTOR FUNCTION	Peak (PK)
FREQUENCY RANGE	1GHz ~ 40GHz		Average (AV)

ANTENNA POLARITY & TEST DISTANCE: HORIZONTAL AT 3 M

NO.	FREQ. (MHz)	EMISSION LEVEL (dBuV/m)	LIMIT (dBuV/m)	MARGIN (dB)	ANTENNA HEIGHT (m)	TABLE ANGLE (Degree)	RAW VALUE (dBuV)	CORRECTION FACTOR (dB/m)
1	*5785.00	101.4 PK			1.69 H	274	91.14	10.27
2	*5785.00	89.6 AV			1.69 H	274	79.36	10.27
3	11570.00	53.6 PK	74.0	-20.4	1.53 H	248	35.37	18.25
4	11570.00	41.5 AV	54.0	-12.5	1.53 H	248	23.27	18.25
5	#17355.00	61.4 PK	74.0	-12.6	1.63 H	202	37.23	24.12
6	#17355.00	46.5 AV	54.0	-7.5	1.63 H	202	22.39	24.12

ANTENNA POLARITY & TEST DISTANCE: VERTICAL AT 3 M

NO.	FREQ. (MHz)	EMISSION LEVEL (dBuV/m)	LIMIT (dBuV/m)	MARGIN (dB)	ANTENNA HEIGHT (m)	TABLE ANGLE (Degree)	RAW VALUE (dBuV)	CORRECTION FACTOR (dB/m)
1	*5785.00	96.9 PK			1.85 V	234	86.65	10.27
2	*5785.00	85.6 AV			1.85 V	234	75.29	10.27
3	11570.00	55.3 PK	74.0	-18.7	1.85 V	248	37.07	18.25
4	11570.00	40.0 AV	54.0	-14.0	1.85 V	248	21.76	18.25
5	#17355.00	60.4 PK	74.0	-13.6	1.95 V	215	36.25	24.12
6	#17355.00	46.6 AV	54.0	-7.4	1.95 V	215	22.51	24.12

REMARKS:

1. Emission level (dBuV/m) = Raw Value (dBuV) + Correction Factor (dB/m).
2. Correction Factor (dB/m) = Antenna Factor (dB/m) + Cable Factor (dB).
3. The other emission levels were very low against the limit.
4. Margin value = Emission level – Limit value.
5. " \* ": Fundamental frequency.
6. " # ": The radiated frequency is out of the restricted band.



<b>CHANNEL</b>	TX Channel 165	<b>DETECTOR FUNCTION</b>	Peak (PK)
<b>FREQUENCY RANGE</b>	1GHz ~ 40GHz		Average (AV)

ANTENNA POLARITY & TEST DISTANCE: HORIZONTAL AT 3 M								
NO.	FREQ. (MHz)	EMISSION LEVEL (dBuV/m)	LIMIT (dBuV/m)	MARGIN (dB)	ANTENNA HEIGHT (m)	TABLE ANGLE (Degree)	RAW VALUE (dBuV)	CORRECTION FACTOR (dB/m)
1	*5825.00	99.4 PK			2.36 H	100	88.92	10.48
2	*5825.00	88.2 AV			2.36 H	100	77.72	10.48
3	5850.00	55.4 PK	78.2	-22.8	2.56 H	100	44.79	10.61
4	5860.00	47.9 PK	68.2	-20.3	2.56 H	100	37.29	10.61
5	11650.00	51.8 PK	74.0	-22.2	2.03 H	221	33.45	18.35
6	11650.00	38.5 AV	54.0	-15.5	2.03 H	221	20.15	18.35
7	#17475.00	60.9 PK	74.0	-13.1	1.96 H	253	36.62	24.28
8	#17475.00	46.5 AV	54.0	-7.5	1.96 H	253	22.22	24.28
ANTENNA POLARITY & TEST DISTANCE: VERTICAL AT 3 M								
NO.	FREQ. (MHz)	EMISSION LEVEL (dBuV/m)	LIMIT (dBuV/m)	MARGIN (dB)	ANTENNA HEIGHT (m)	TABLE ANGLE (Degree)	RAW VALUE (dBuV)	CORRECTION FACTOR (dB/m)
1	*5825.00	95.4 PK			1.96 V	249	84.92	10.48
2	*5825.00	89.0 AV			1.96 V	249	78.52	10.48
3	5850.00	49.6 PK	78.2	-28.6	1.96 V	249	38.99	10.61
4	5860.00	47.6 PK	68.2	-20.6	1.96 V	249	36.99	10.61
5	11650.00	51.5 PK	74.0	-22.5	1.47 V	253	33.15	18.35
6	11650.00	39.2 AV	54.0	-14.8	1.47 V	253	20.85	18.35
7	#17475.00	58.5 PK	74.0	-15.5	1.85 V	152	34.22	24.28
8	#17475.00	45.5 AV	54.0	-8.5	1.85 V	152	21.22	24.28

**REMARKS:**

1. Emission level (dBuV/m) = Raw Value (dBuV) + Correction Factor (dB/m).
2. Correction Factor (dB/m) = Antenna Factor (dB/m) + Cable Factor (dB).
3. The other emission levels were very low against the limit.
4. Margin value = Emission level – Limit value.
5. " \* ": Fundamental frequency.
6. " # ": The radiated frequency is out of the restricted band.



802.11n (40MHz)

<b>CHANNEL</b>	TX Channel 151	<b>DETECTOR FUNCTION</b>	Peak (PK)
<b>FREQUENCY RANGE</b>	1GHz ~ 40GHz		Average (AV)

**ANTENNA POLARITY & TEST DISTANCE: HORIZONTAL AT 3 M**

NO.	FREQ. (MHz)	EMISSION LEVEL (dBuV/m)	LIMIT (dBuV/m)	MARGIN (dB)	ANTENNA HEIGHT (m)	TABLE ANGLE (Degree)	RAW VALUE (dBuV)	CORRECTION FACTOR (dB/m)
1	5715.00	64.7 PK	68.2	-3.5	1.84 H	296	54.79	9.91
2	5725.00	70.5 PK	78.2	-7.7	1.84 H	296	60.59	9.91
3	*5755.00	98.3 PK			1.84 H	296	88.18	10.12
4	*5755.00	86.2 AV			1.84 H	296	76.08	10.12
5	11510.00	53.6 PK	74.0	-20.4	1.69 H	284	35.43	18.17
6	11510.00	41.6 AV	54.0	-12.4	1.69 H	284	23.43	18.17
7	#17265.00	60.4 PK	74.0	-13.6	1.48 H	263	36.40	24.00
8	#17265.00	48.3 AV	54.0	-5.7	1.48 H	263	24.30	24.00

**ANTENNA POLARITY & TEST DISTANCE: VERTICAL AT 3 M**

NO.	FREQ. (MHz)	EMISSION LEVEL (dBuV/m)	LIMIT (dBuV/m)	MARGIN (dB)	ANTENNA HEIGHT (m)	TABLE ANGLE (Degree)	RAW VALUE (dBuV)	CORRECTION FACTOR (dB/m)
1	5715.00	53.6 PK	68.2	-14.6	2.63 V	153	43.69	9.91
2	5725.00	58.6 PK	78.2	-19.6	2.63 V	153	48.69	9.91
3	*5755.00	93.3 PK			2.63 V	153	83.18	10.12
4	*5755.00	82.3 AV			2.63 V	153	72.18	10.12
5	11510.00	53.3 PK	74.0	-20.7	2.63 V	148	35.13	18.17
6	11510.00	38.4 AV	54.0	-15.6	2.63 V	148	20.23	18.17
7	#17265.00	58.4 PK	74.0	-15.6	1.85 V	203	34.40	24.00
8	#17265.00	47.6 AV	54.0	-6.4	1.85 V	203	23.60	24.00

**REMARKS:**

1. Emission level (dBuV/m) = Raw Value (dBuV) + Correction Factor (dB/m).
2. Correction Factor (dB/m) = Antenna Factor (dB/m) + Cable Factor (dB).
3. The other emission levels were very low against the limit.
4. Margin value = Emission level – Limit value.
5. " \* ": Fundamental frequency.
6. " # ": The radiated frequency is out of the restricted band.



<b>CHANNEL</b>	TX Channel 159	<b>DETECTOR FUNCTION</b>	Peak (PK)
<b>FREQUENCY RANGE</b>	1GHz ~ 40GHz		Average (AV)

<b>ANTENNA POLARITY &amp; TEST DISTANCE: HORIZONTAL AT 3 M</b>								
NO.	FREQ. (MHz)	EMISSION LEVEL (dBuV/m)	LIMIT (dBuV/m)	MARGIN (dB)	ANTENNA HEIGHT (m)	TABLE ANGLE (Degree)	RAW VALUE (dBuV)	CORRECTION FACTOR (dB/m)
1	*5795.00	98.9 PK			1.10 H	125	88.58	10.32
2	*5795.00	86.8 AV			1.10 H	125	76.48	10.32
3	5850.00	55.6 PK	78.2	-22.6	1.10 H	125	44.99	10.61
4	5860.00	49.0 PK	68.2	-19.2	1.10 H	125	38.39	10.61
5	11590.00	54.9 PK	74.0	-19.2	1.56 H	254	36.63	18.27
6	11590.00	38.4 AV	54.0	-15.6	1.56 H	254	20.13	18.27
7	#17385.00	60.8 PK	74.0	-13.2	1.20 H	306	36.65	24.15
8	#17385.00	46.5 AV	54.0	-7.5	1.20 H	306	22.35	24.15
<b>ANTENNA POLARITY &amp; TEST DISTANCE: VERTICAL AT 3 M</b>								
NO.	FREQ. (MHz)	EMISSION LEVEL (dBuV/m)	LIMIT (dBuV/m)	MARGIN (dB)	ANTENNA HEIGHT (m)	TABLE ANGLE (Degree)	RAW VALUE (dBuV)	CORRECTION FACTOR (dB/m)
1	*5795.00	94.2 PK			2.63 V	215	83.88	10.32
2	*5795.00	82.6 AV			2.63 V	215	72.28	10.32
3	5850.00	48.3 PK	78.2	-29.9	2.63 V	215	37.69	10.61
4	5860.00	47.1 PK	68.2	-21.1	2.63 V	215	36.49	10.61
5	11590.00	53.6 PK	74.0	-20.4	1.74 V	202	35.33	18.27
6	11590.00	39.9 AV	54.0	-14.1	1.74 V	202	21.63	18.27
7	#17385.00	59.2 PK	74.0	-14.8	1.65 V	230	35.05	24.15
8	#17385.00	45.8 AV	54.0	-8.2	1.65 V	230	21.65	24.15

**REMARKS:**

- Emission level (dBuV/m) = Raw Value (dBuV) + Correction Factor (dB/m).
- Correction Factor (dB/m) = Antenna Factor (dB/m) + Cable Factor (dB).
- The other emission levels were very low against the limit.
- Margin value = Emission level – Limit value.
- " \* ": Fundamental frequency.
- " # ": The radiated frequency is out of the restricted band.



802.11ac 80MHz

<b>CHANNEL</b>	TX Channel 155	<b>DETECTOR FUNCTION</b>	Peak (PK)
<b>FREQUENCY RANGE</b>	1GHz ~ 40GHz		Average (AV)

ANTENNA POLARITY & TEST DISTANCE: HORIZONTAL AT 3 M

NO.	FREQ. (MHz)	EMISSION LEVEL (dBuV/m)	LIMIT (dBuV/m)	MARGIN (dB)	ANTENNA HEIGHT (m)	TABLE ANGLE (Degree)	RAW VALUE (dBuV)	CORRECTION FACTOR (dB/m)
1	5715.00	65.5 PK	68.2	-2.7	1.95 H	140	55.59	9.91
2	5725.00	70.6 PK	78.2	-7.6	1.95 H	140	60.69	9.91
3	*5775.00	94.8 PK			1.95 H	140	84.58	10.22
4	*5775.00	81.5 AV			1.95 H	140	71.28	10.22
5	5850.00	68.5 PK	78.2	-9.7	1.95 H	140	57.89	10.61
6	5860.00	62.8 PK	68.2	-5.4	1.95 H	140	52.19	10.61
7	11550.00	52.1 PK	74.0	-21.9	2.15 H	302	33.88	18.22
8	11550.00	38.0 AV	54.0	-16.0	2.15 H	302	19.78	18.22
9	#17325.00	58.5 PK	74.0	-15.5	1.69 H	300	34.42	24.08
10	#17325.00	47.3 AV	54.0	-6.7	1.69 H	300	23.22	24.08

ANTENNA POLARITY & TEST DISTANCE: VERTICAL AT 3 M

NO.	FREQ. (MHz)	EMISSION LEVEL (dBuV/m)	LIMIT (dBuV/m)	MARGIN (dB)	ANTENNA HEIGHT (m)	TABLE ANGLE (Degree)	RAW VALUE (dBuV)	CORRECTION FACTOR (dB/m)
1	5715.00	60.8 PK	68.2	-7.4	1.62 V	208	50.89	9.91
2	5725.00	61.3 PK	78.2	-16.9	1.62 V	208	51.39	9.91
3	*5775.00	90.8 PK			1.62 V	208	80.58	10.22
4	*5775.00	77.5 AV			1.62 V	208	67.28	10.22
5	5850.00	64.9 PK	78.2	-13.3	1.62 V	208	54.29	10.61
6	5860.00	63.6 PK	68.2	-4.6	1.62 V	208	52.99	10.61
7	11550.00	54.0 PK	74.0	-20.0	1.65 V	201	35.78	18.22
8	11550.00	41.3 AV	54.0	-12.7	1.65 V	201	23.08	18.22
9	#17325.00	60.3 PK	74.0	-13.7	1.49 V	284	36.22	24.08
10	#17325.00	48.3 AV	54.0	-5.7	1.49 V	284	24.22	24.08

REMARKS:

1. Emission level (dBuV/m) = Raw Value (dBuV) + Correction Factor (dB/m).
2. Correction Factor (dB/m) = Antenna Factor (dB/m) + Cable Factor (dB).
3. The other emission levels were very low against the limit.
4. Margin value = Emission level – Limit value.
5. " \* ": Fundamental frequency.
6. " # ": The radiated frequency is out of the restricted band.



### 3.2 CONDUCTED EMISSION MEASUREMENT

#### 3.2.1 LIMITS OF CONDUCTED EMISSION MEASUREMENT

FREQUENCY OF EMISSION (MHz)	CONDUCTED LIMIT (dBµV)	
	Quasi-peak	Average
0.15 ~ 0.5	66 to 56	56 to 46
0.5 ~ 5	56	46
5 ~ 30	60	50

- NOTE:**
1. The lower limit shall apply at the transition frequencies.
  2. The limit decreases in line with the logarithm of the frequency in the range of 0.15 to 0.50MHz.
  3. All emanations from a class A/B digital device or system, including any network of conductors and apparatus connected thereto, shall not exceed the level of field strengths specified above.

#### 3.2.2 TEST INSTRUMENTS

Equipment	Manufacturer	Model No.	Serial No.	Last Cal.	Next Cal.
EMI Test Receiver	Rohde&Schwarz	ESR7	101588	Jan. 22,16	Jan. 21,17
Artificial Mains Network	Rohde&Schwarz	ENV216	101173	Mar. 04,16	Mar. 03,17
Artificial Mains Network	Rohde&Schwarz	ESH3-Z5	100317	Apr. 05,16	Apr. 04,17
Voltage probe	SCHWARZBEC K	TK 9421	TK 9421-176	Jan. 08,16	Jan. 07,17
Test software	ADT	ADT_Cond_ V7.3.7	N/A	N/A	N/A

- NOTE:**
1. The test was performed in shielded room 553.
  2. The calibration interval of the above test instruments is 12 months. And the calibrations are traceable to CEPREI/CHINA, GRGT/CHINA and NIM/CHINA.



### 3.2.3 TEST PROCEDURES

- The EUT was placed 0.4 meters from the conducting wall of the shielded room with EUT being connected to the power mains through a line impedance stabilization network (LISN). Other support units were connected to the power mains through another LISN. The two LISNs provide 50 ohm/ 50uH of coupling impedance for the measuring instrument.
- Both lines of the power mains connected to the EUT were checked for maximum conducted interference.
- The frequency range from 150kHz to 30MHz was searched. Emission levels under (Limit - 20dB) were not recorded.

**NOTE:** All modes of operation were investigated and the worst-case emissions are reported.

### 3.2.4 DEVIATION FROM TEST STANDARD

No deviation.

### 3.2.5 TEST SETUP

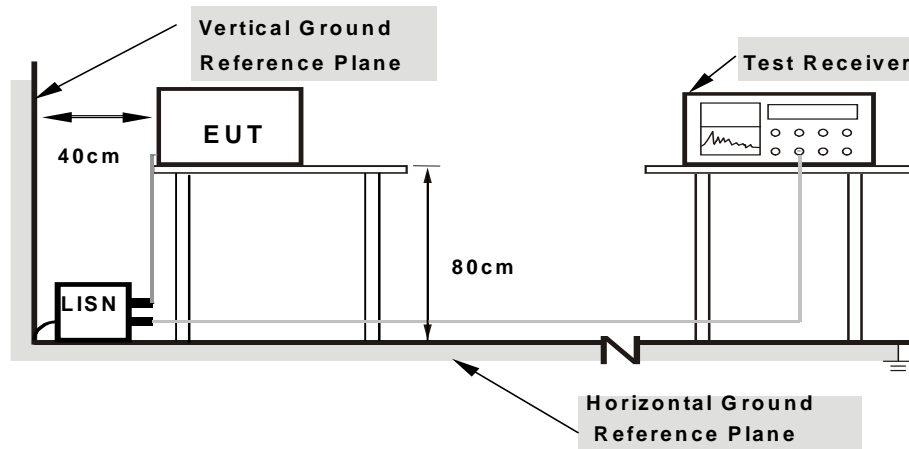

- Note:**
- Support units were connected to second LISN.
  - Both of LISNs (AMN) are 80 cm from EUT and at least 80 from other units and other metal planes

For the actual test configuration, please refer to the attached file (Test Setup Photo).

### 3.2.6 EUT OPERATING CONDITIONS

Same as 3.1.6



**3.2.7 TEST RESULTS**

**CONDUCTED WORST-CASE DATA: 802.11a**

<b>PHASE</b>	Line	<b>6dB BANDWIDTH</b>	9kHz
--------------	------	----------------------	------

No	Freq. [MHz]	Corr. Factor (dB)	Reading Value		Emission Level		Limit		Margin	
			[dB (uV)]		[dB (uV)]		[dB (uV)]		(dB)	
			Q.P.	AV.	Q.P.	AV.	Q.P.	AV.	Q.P.	AV.
1	0.17025	10.04	35.53	15.56	45.57	25.60	64.95	54.95	-19.38	-29.35
2	0.23290	10.05	29.34	11.08	39.39	21.13	62.35	52.35	-22.95	-31.21
3	0.28541	10.07	23.92	8.49	33.99	18.56	60.66	50.66	-26.67	-32.10
4	1.19706	10.14	14.56	12.92	24.70	23.06	56.00	46.00	-31.30	-22.94
5	3.59250	10.15	19.22	15.55	29.37	25.70	56.00	46.00	-26.63	-20.30
6	11.58450	10.18	18.50	13.40	28.68	23.58	60.00	50.00	-31.32	-26.42

- REMARKS:**
1. Q.P. and AV. are abbreviations of quasi-peak and average individually.
  2. The emission levels of other frequencies were very low against the limit.
  3. Margin value = Emission level - Limit value
  4. Correction factor = Insertion loss + Cable loss
  5. Emission Level = Correction Factor + Reading Value.

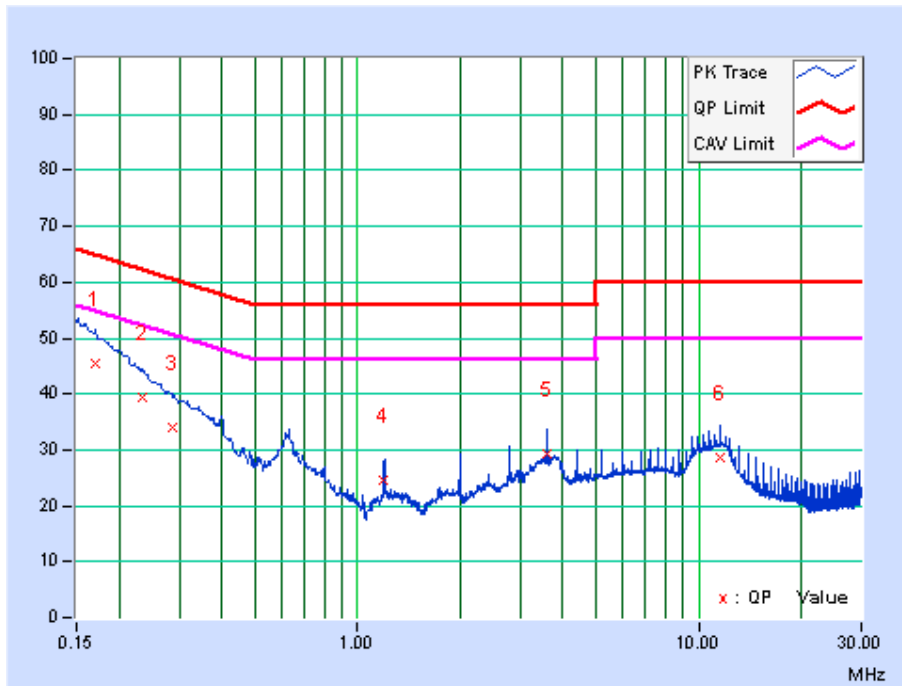



<b>PHASE</b>	Neutral	<b>6dB BANDWIDTH</b>	9kHz
--------------	---------	----------------------	------

No	Freq. [MHz]	Corr. Factor (dB)	Reading Value		Emission Level		Limit		Margin	
			[dB (uV)]		[dB (uV)]		[dB (uV)]		(dB)	
			Q.P.	AV.	Q.P.	AV.	Q.P.	AV.	Q.P.	AV.
1	0.15900	9.84	36.69	16.54	46.53	26.38	65.52	55.52	-18.99	-29.14
2	0.19258	9.84	33.21	13.77	43.05	23.61	63.92	53.92	-20.87	-30.31
3	0.24167	9.84	27.71	10.85	37.55	20.69	62.04	52.04	-24.49	-31.35
4	0.36581	9.84	17.76	4.85	27.60	14.69	58.60	48.60	-31.00	-33.91
5	3.59250	9.90	18.58	14.26	28.48	24.16	56.00	46.00	-27.52	-21.84
6	11.58450	10.11	18.74	13.82	28.85	23.93	60.00	50.00	-31.15	-26.07

- REMARKS:**
1. Q.P. and AV. are abbreviations of quasi-peak and average individually.
  2. The emission levels of other frequencies were very low against the limit.
  3. Margin value = Emission level - Limit value
  4. Correction factor = Insertion loss + Cable loss
  5. Emission Level = Correction Factor + Reading Value.

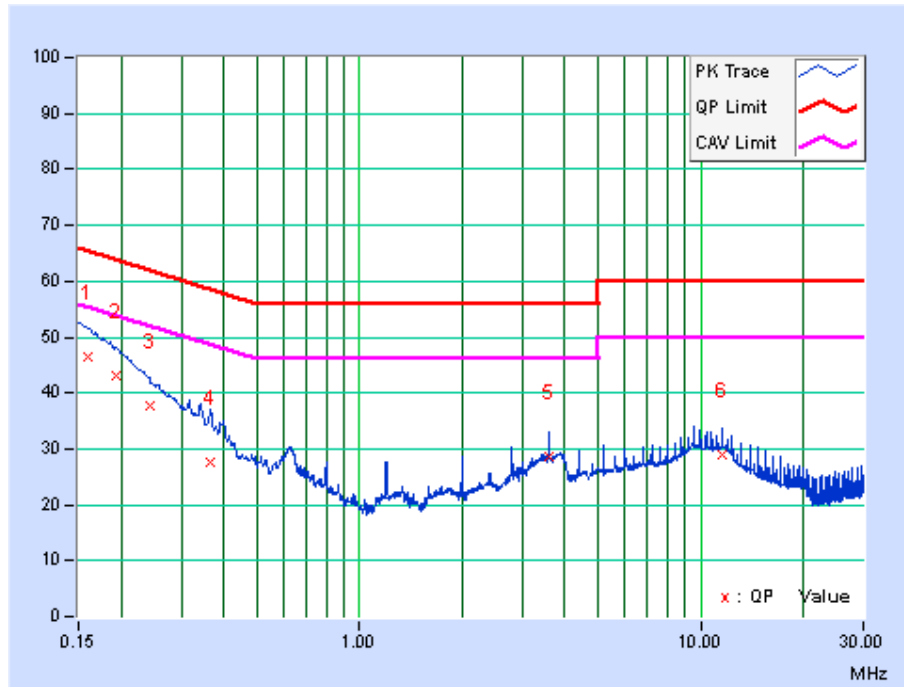



### 3.3 TRANSMIT POWER MEASUREMENT

#### 3.3.1 LIMITS OF TRANSMIT POWER MEASUREMENT

Operation Band	EUT Category		LIMIT
U-NII-1		Outdoor Access Point	1 Watt (30 dBm) (Max. e.i.r.p $\leq$ 125mW(21 dBm) at any elevation angle above 30 degrees as measured from the horizon)
		Fixed point-to-point Access Point	1 Watt (30 dBm)
		Indoor Access Point	1 Watt (30 dBm)
	√	Mobile and Portable client device	250mW (24 dBm)
U-NII-2A		√	250mW(24dBm) or 11 dBm+10LogB*
U-NII-2C		√	250mW(24dBm) or 11 dBm+10LogB*
U-NII-3		√	1 Watt (30 dBm)

NOTE: 1. Where B is the 26dB emission bandwidth in MHz.

#### 3.3.2 TEST SETUP

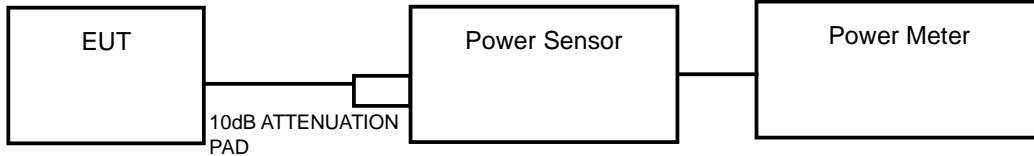

#### FOR 6/26dB BANDWIDTH

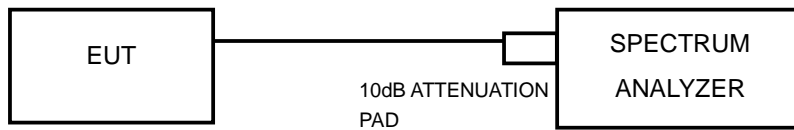



### 3.3.3 TEST INSTRUMENTS

Equipment	Manufacturer	Model No.	Serial No.	Last Cal.	Next Cal.
Power Sensor	Keysight	U2021XA	MY55060016	May 04,16	May 03,17
Power Sensor	Keysight	U2021XA	MY55060018	May 04,16	May 03,17
Digital Multimeter	FLUKE	15B	A1220010DG	Oct. 12, 15	Oct.11, 16
Humid & Temp Programmable Tester	Haida	HD-2257	110807201	Sep.07,15	Sep. 06,16
Oscilloscope	Agilent	DSO9254A	MY51260160	Nov. 28,15	Nov. 27,16
Signal Analyzer	Rohde & Schwarz	FSV7	102331	Nov. 09,15	Nov. 08,16
Signal Generator	Agilent	N5183A	MY50140980	Nov. 09,15	Nov. 08,16
Agile Signal Generator	Agilent	8645A	Agilent	Aug.08, 16	Aug.07, 17
ESG Vector Signal Generator	Agilent	E4438C	MY49072505	Apr. 22, 16	Apr. 21, 17
BLUETOOTH TESTER	Rohde&Schwarz	CBT32	100811	Aug.08, 16	Aug.07, 17

**NOTE:**

1. The test was performed in RF Oven room.
2. The calibration interval of the above test instruments is 12 months and the calibrations are traceable to CEPREI/CHINA, GRGT/CHINA and NIM/CHINA.

### 3.3.4 TEST PROCEDURE

#### FOR AVERAGE POWER MEASUREMENT

Method PM is used to perform output power measurement, trigger and gating function of wide band power meter is enabled to measure max output power of TX on burst. Duty factor is not added to measured value.

#### FOR 26dB BANDWIDTH

- 1) Set RBW = approximately 1% of the emission bandwidth.
- 2) Set the VBW > RBW.
- 3) Detector = RMS.
- 4) Trace mode = max hold.
- 5) Measure the maximum width of the emission that is 26 dB down from the peak of the emission. Compare this with the RBW setting of the analyzer. Readjust RBW and repeat measurement as needed until the RBW/EBW ratio is approximately 1%.



#### **FOR 6dB BANDWIDTH**

- 1) Set RBW = 100 kHz.
- 2) Set the video bandwidth (VBW)  $\geq 3$  RBW.
- 3) Detector = Peak.
- 4) Trace mode = max hold.
- 5) Sweep = auto couple.
- 6) Allow the trace to stabilize.
- 7) Measure the maximum width of the emission that is constrained by the frequencies associated with the two outermost amplitude points (upper and lower frequencies) that are attenuated by 6 dB relative to the maximum level measured in the fundamental emission.

#### **3.3.5 DEVIATION FROM TEST STANDARD**

No deviation.

#### **3.3.6 EUT OPERATING CONDITIONS**

The software provided by client to enable the EUT under transmission condition continuously at specific channel frequencies individually.



### 3.3.7 TEST RESULTS

#### OUTPUT POWER:

##### 802.11a

Channel Number	FREQ. (MHz)	AVG. CONDUCTED POWER (dBm)	LIMIT (dBm)	PASS /FAIL
36	5180	18.34	24.00	PASS
40	5200	18.64	24.00	PASS
48	5240	18.56	24.00	PASS
52	5260	18.39	24.00	PASS
60	5300	18.62	24.00	PASS
64	5320	18.75	24.00	PASS
100	5500	19.02	24.00	PASS
116	5580	18.98	24.00	PASS
140	5700	19.11	24.00	PASS
149	5745	18.56	30.00	PASS
157	5785	18.84	30.00	PASS
165	5825	<b>18.93</b>	30.00	PASS

For Band 2~Band 3: Limit =  $11\text{dBm} + 10\log(26\text{ BW}) = 11 + 10\log(20.05) = 24.02\text{dBm} > 24\text{dBm}$



802.11n (20MHz)

Channel Number	FREQ. (MHz)	AVG. CONDUCTED POWER (dBm)	LIMIT (dBm)	PASS /FAIL
36	5180	18.64	24.00	PASS
40	5200	18.55	24.00	PASS
48	5240	18.76	24.00	PASS
52	5260	18.68	24.00	PASS
60	5300	18.69	24.00	PASS
64	5320	<b>18.86</b>	24.00	PASS
100	5500	19.08	24.00	PASS
116	5580	<b>19.14</b>	24.00	PASS
140	5700	19.06	24.00	PASS
149	5745	18.62	30.00	PASS
157	5785	18.78	30.00	PASS
165	5825	18.92	30.00	PASS

For Band 2~Band 3: Limit = 11dBm+10log(26 BW)=11+10log(20.05)=24.02dBm > 24dBm



**802.11n (40MHz)**

Channel Number	FREQ. (MHz)	AVG. CONDUCTED POWER (dBm)	LIMIT (dBm)	PASS /FAIL
38	5190	18.74	24.00	PASS
46	5230	18.65	24.00	PASS
54	5270	18.59	24.00	PASS
62	5310	18.83	24.00	PASS
102	5510	19.02	24.00	PASS
110	5550	18.96	24.00	PASS
134	5670	19.07	24.00	PASS
151	5755	18.66	30.00	PASS
159	5795	18.73	30.00	PASS

**802.11ac (80MHz)**

Channel Number	FREQ. (MHz)	AVG. CONDUCTED POWER (dBm)	LIMIT (dBm)	PASS /FAIL
42	5210	<b>18.86</b>	24.00	PASS
58	5290	18.75	24.00	PASS
106	5530	18.90	24.00	PASS
155	5775	18.85	30.00	PASS



## 26dB BANDWIDTH:

### 802.11a

Channel Number	Freq. (MHz)	26dB DOWN BANDWIDTH (MHz)	PASS /FAIL
36	5180	20.26	PASS
40	5200	20.07	PASS
48	5240	20.20	PASS
52	5260	20.24	PASS
60	5300	20.19	PASS
64	5320	20.17	PASS
100	5500	20.29	PASS
116	5580	20.05	PASS
140	5700	20.17	PASS

### 802.11n (20MHz)

Channel Number	Freq. (MHz)	26dB DOWN BANDWIDTH (MHz)	PASS /FAIL
36	5180	20.44	PASS
40	5200	20.49	PASS
48	5240	20.31	PASS
52	5260	20.35	PASS
60	5300	20.49	PASS
64	5320	20.45	PASS
100	5500	20.35	PASS
116	5580	20.47	PASS
140	5700	20.40	PASS



**802.11n (40MHz)**

Channel Number	Freq. (MHz)	26dB DOWN BANDWIDTH (MHz)	PASS /FAIL
38	5190	41.65	PASS
46	5230	41.90	PASS
54	5270	41.68	PASS
62	5310	41.68	PASS
102	5510	41.82	PASS
110	5550	42.03	PASS
134	5670	57.43	PASS

**802.11ac (80MHz)**

Channel Number	Freq. (MHz)	26dB DOWN BANDWIDTH (MHz)	PASS /FAIL
42	5210	155.48	PASS
58	5290	151.15	PASS
106	5530	159.02	PASS



**6dB BANDWIDTH For 5725-5850MHz**

**802.11a**

Channel Number	Freq. (MHz)	6dB DOWN BANDWIDTH (MHz)	PASS /FAIL
149	5745	16.36	PASS
157	5785	16.40	PASS
165	5825	16.41	PASS

**802.11n (20M)**

Channel Number	Freq. (MHz)	6dB DOWN BANDWIDTH (MHz)	PASS /FAIL
149	5745	17.36	PASS
157	5785	17.37	PASS
165	5825	17.60	PASS

**802.11n (40M)**

Channel Number	Freq. (MHz)	6dB DOWN BANDWIDTH (MHz)	PASS /FAIL
151	5755	35.58	PASS
159	5795	35.36	PASS

**802.11ac (80MHz)**

Channel Number	Freq. (MHz)	6dB DOWN BANDWIDTH (MHz)	PASS /FAIL
155	5775	76.27	PASS



**BUREAU  
VERITAS**

Test Report No.: RF160712N001-3

**26dB bandwidth Test Plot  
For 5150-5250MHz worst plot**

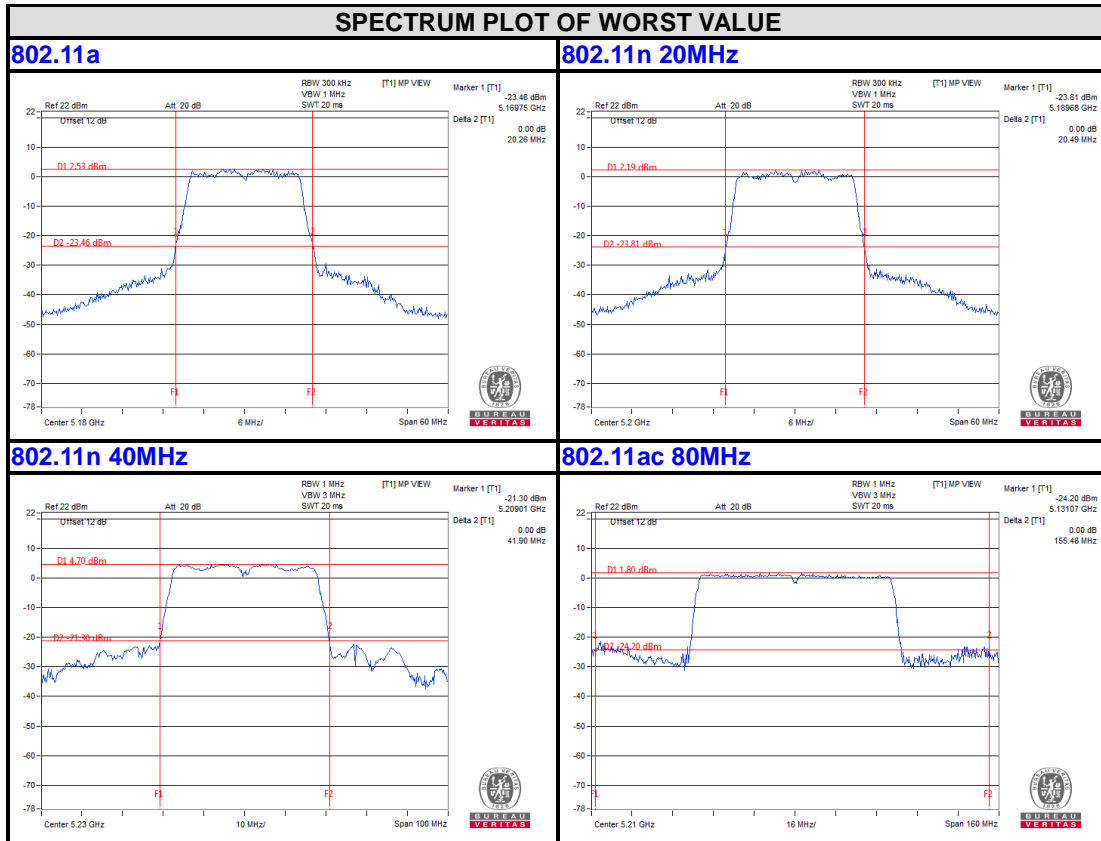



**BUREAU  
VERITAS**

Test Report No.: RF160712N001-3

For 5250-5350MHz

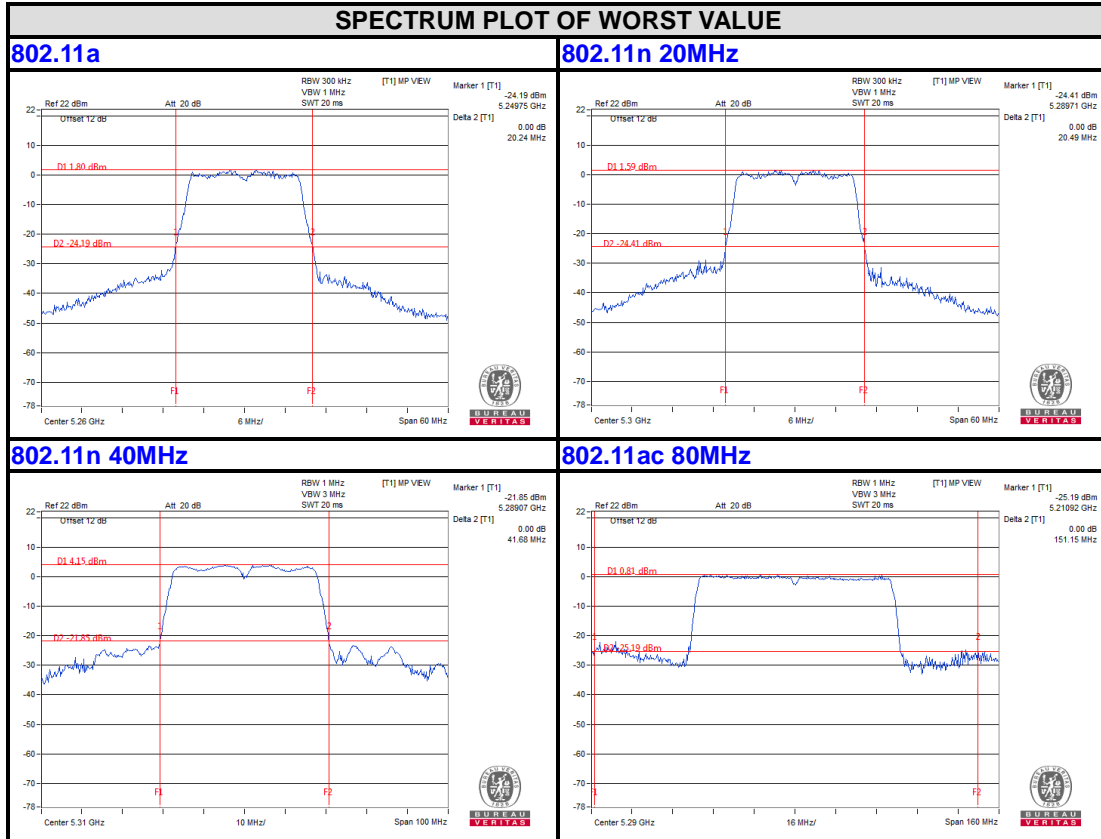

Bureau Veritas Shenzhen Co., Ltd.  
Dongguan Branch

No. 34, Chenwulu Section, Guantai Rd., Houjie  
Town, Dongguan City,  
Guangdong 523942, China

Tel: +86 769 8593 5656  
Fax: +86 769 8593 1080  
Email: [customerservice.dg@cn.bureauveritas.com](mailto:customerservice.dg@cn.bureauveritas.com)



BUREAU VERITAS

Test Report No.: RF160712N001-3

For 5470-5725MHz

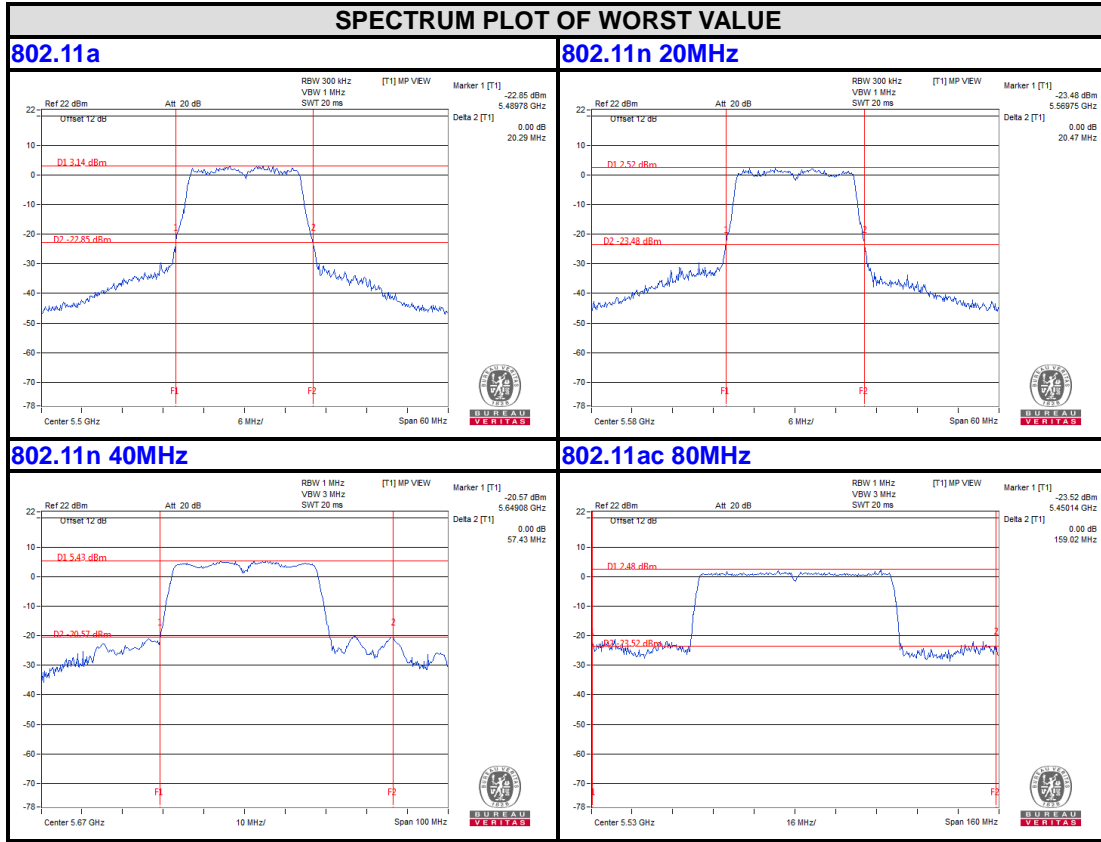

Bureau Veritas Shenzhen Co., Ltd.  
Dongguan Branch

No. 34, Chenwulu Section, Guantai Rd., Houjie  
Town, Dongguan City,  
Guangdong 523942, China

Tel: +86 769 8593 5656  
Fax: +86 769 8593 1080  
Email: [customerservice.dg@cn.bureauveritas.com](mailto:customerservice.dg@cn.bureauveritas.com)



**BUREAU  
VERITAS**

Test Report No.: RF160712N001-3

6dB BANDWIDTH For 5725-5850MHz

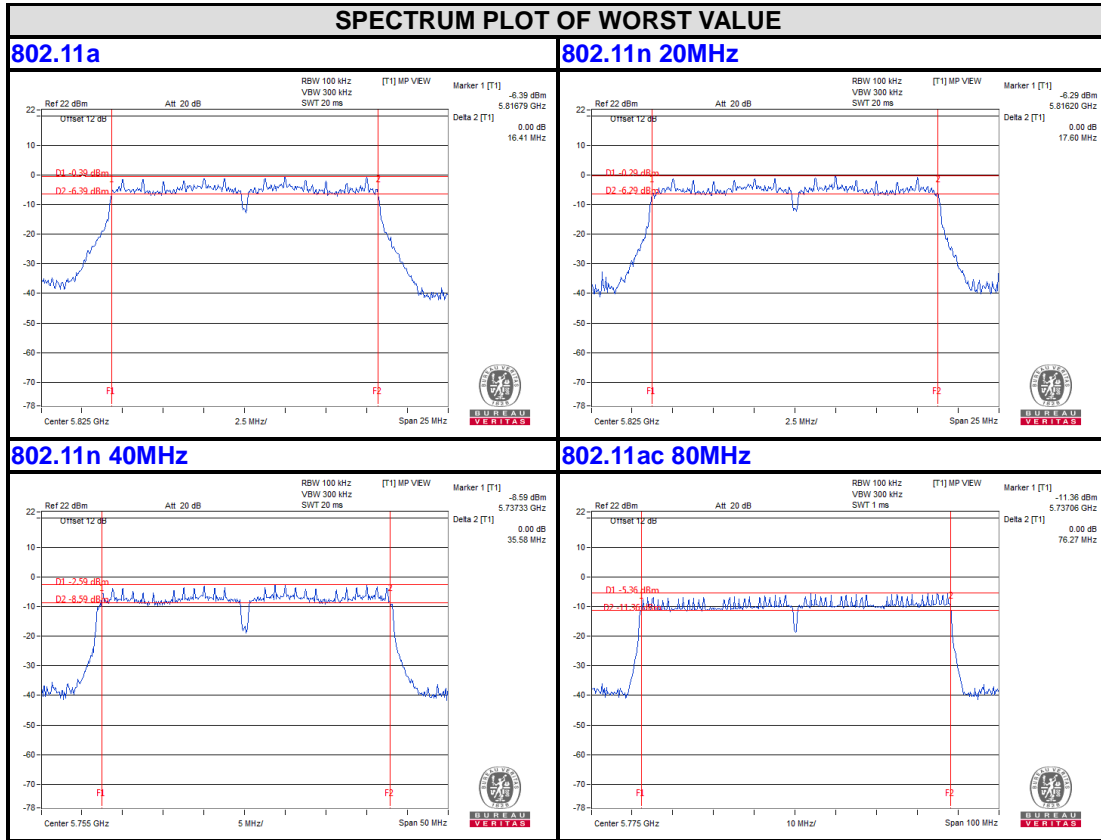

Bureau Veritas Shenzhen Co., Ltd.  
Dongguan Branch

No. 34, Chenwulu Section, Guantai Rd., Houjie  
Town, Dongguan City,  
Guangdong 523942, China

Tel: +86 769 8593 5656  
Fax: +86 769 8593 1080  
Email: [customerservice.dg@cn.bureauveritas.com](mailto:customerservice.dg@cn.bureauveritas.com)



### 3.4 PEAK POWER SPECTRAL DENSITY MEASUREMENT

#### 3.4.1 LIMITS OF PEAK POWER SPECTRAL DENSITY MEASUREMENT

Operation Band	EUT Category		LIMIT
U-NII-1		Outdoor Access Point	17dBm/ MHz
		Fixed point-to-point Access Point	
		Indoor Access Point	
	√	Mobile and Portable client device	11dBm/ MHz
U-NII-2A	√		11dBm/ MHz
U-NII-2C	√		11dBm/ MHz
U-NII-3	√		30dBm/ 500kHz

#### 3.4.2 TEST SETUP

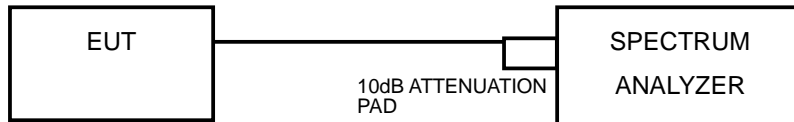

#### 3.4.3 TEST INSTRUMENTS

Refer to section 3.3.3 to get information of above instrument.

#### 3.4.4 TEST PROCEDURES

##### For U-NII-1, U-NII-2A, U-NII-2C band:

Using method SA-2

- 1) Set span to encompass the entire emission bandwidth (EBW) of the signal.
- 2) Set RBW = 1MHz, Set VBW =3 MHz, Detector = RMS
- 3) Set Channel power measure = 1MHz
- 4) Sweep time = auto, trigger set to “free run”.
- 5) Trace average at least 100 traces in power averaging mode.
- 6) Record the max value and add 10 log (1/duty cycle)



**For U-NII-3 band:**

Using method SA-2

- 1) Set span to encompass the entire emission bandwidth (EBW) of the signal.
- 2) Set RBW = 300 kHz, Set VBW = 1 MHz, Detector = RMS
- 3) Set Channel power measure = 1MHz
- 4) Sweep time = auto, trigger set to "free run".
- 5) Trace average at least 100 traces in power averaging mode.
- 6) Record the max value and add 10 log (1/duty cycle)

**3.4.5 DEVIATION FROM TEST STANDARD**

No deviation.

**3.4.6 EUT OPERATING CONDITIONS**

Same as 3.3.6



### 3.4.7 TEST RESULTS

For U-NII-1, U-NII-2A & U-NII-2C, For U-NII-3:  
802.11a

Channel Number	Frequency (MHz)	RF Power Level in 1MHz BW (dBm)	Total power density (mW)	MAX. Limit (dBm)	PASS / FAIL
36	5180	-1.50	0.6577	11.00	PASS
40	5200	-1.90	0.5754	11.00	PASS
48	5240	-2.19	0.5559	11.00	PASS
52	5260	-2.39	0.5248	11.00	PASS
60	5300	-2.58	0.5176	11.00	PASS
64	5320	-2.49	0.5105	11.00	PASS
100	5500	-1.10	0.7762	11.00	PASS
116	5580	-1.84	0.6577	11.00	PASS
140	5700	-1.37	0.7295	11.00	PASS
Channel Number	Frequency (MHz)	RF Power Level in 300kHz BW (dBm)	RF Power Level in 500kHz BW (dBm)	MAX. Limit (dBm/500k)	PASS / FAIL
149	5745	-9.50	-7.28	30.00	PASS
157	5785	-9.78	-7.56	30.00	PASS
165	5825	-10.44	-8.22	30.00	PASS



802.11n (20MHz)

Channel Number	Frequency (MHz)	RF Power Level in 1MHz BW (dBm)	Total power density (mW)	MAX. Limit (dBm)	PASS / FAIL
36	5180	-2.05	0.6237	11.00	PASS
40	5200	-2.23	0.5984	11.00	PASS
48	5240	-2.71	0.5358	11.00	PASS
52	5260	-2.71	0.5358	11.00	PASS
60	5300	-2.94	0.5082	11.00	PASS
64	5320	-2.88	0.5152	11.00	PASS
100	5500	-1.49	0.7096	11.00	PASS
116	5580	-2.05	0.6237	11.00	PASS
140	5700	-1.84	0.6546	11.00	PASS
Channel Number	Frequency (MHz)	RF Power Level in 300kHz BW (dBm)	RF Power Level in 500kHz BW (dBm)	MAX. Limit (dBm/500k)	PASS / FAIL
149	5745	-10.10	-7.88	30.00	PASS
157	5785	-10.25	-8.03	30.00	PASS
165	5825	-10.67	-8.45	30.00	PASS



**802.11n (40MHz)**

Channel Number	Frequency (MHz)	RF Power Level in 1MHz BW (dBm)	Total power density (mW)	MAX. Limit (dBm)	PASS / FAIL
38	5190	-5.02	0.3148	11.00	PASS
46	5230	-5.66	0.2716	11.00	PASS
54	5270	-6.02	0.2500	11.00	PASS
62	5310	-6.05	0.2483	11.00	PASS
102	5510	-4.67	0.3412	11.00	PASS
110	5550	-5.19	0.3027	11.00	PASS
134	5670	-4.88	0.3251	11.00	PASS
Channel Number	Frequency (MHz)	RF Power Level in 300kHz BW (dBm)	RF Power Level in 500kHz BW (dBm)	MAX. Limit (dBm/500k)	PASS / FAIL
151	5755	-13.09	-10.87	30.00	PASS
159	5795	-13.21	-10.99	30.00	PASS

**802.11ac (80MHz)**

Channel Number	Frequency (MHz)	RF Power Level in 1MHz BW (dBm)	Total power density (mW)	MAX. Limit (dBm)	PASS / FAIL
42	5210	-9.15	0.1216	11.00	PASS
58	5290	-9.52	0.1117	11.00	PASS
106	5530	-8.75	0.1334	11.00	PASS
Channel Number	Frequency (MHz)	RF Power Level in 300kHz BW (dBm)	RF Power Level in 500kHz BW (dBm)	MAX. Limit (dBm/500k)	PASS / FAIL
155	5775	-16.74	-14.52	30.00	PASS



**BUREAU  
VERITAS**

Test Report No.: RF160712N001-3

PSD Test Plot  
BAND 1  
5150-5250MHz

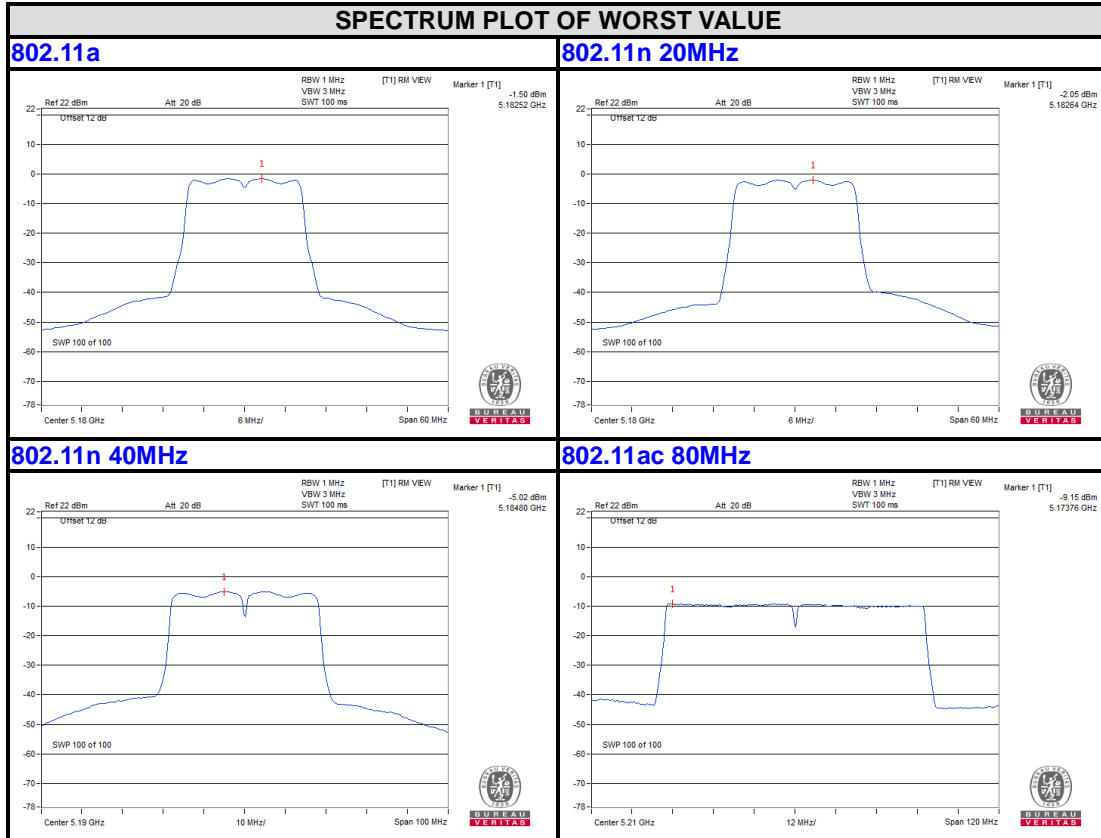

Bureau Veritas Shenzhen Co., Ltd.  
Dongguan Branch

No. 34, Chenwulu Section, Guantai Rd., Houjie  
Town, Dongguan City,  
Guangdong 523942, China

Tel: +86 769 8593 5656  
Fax: +86 769 8593 1080  
Email: [customerservice.dg@cn.bureauveritas.com](mailto:customerservice.dg@cn.bureauveritas.com)



**BUREAU  
VERITAS**

Test Report No.: RF160712N001-3

BAND 2  
5250-5350MHz

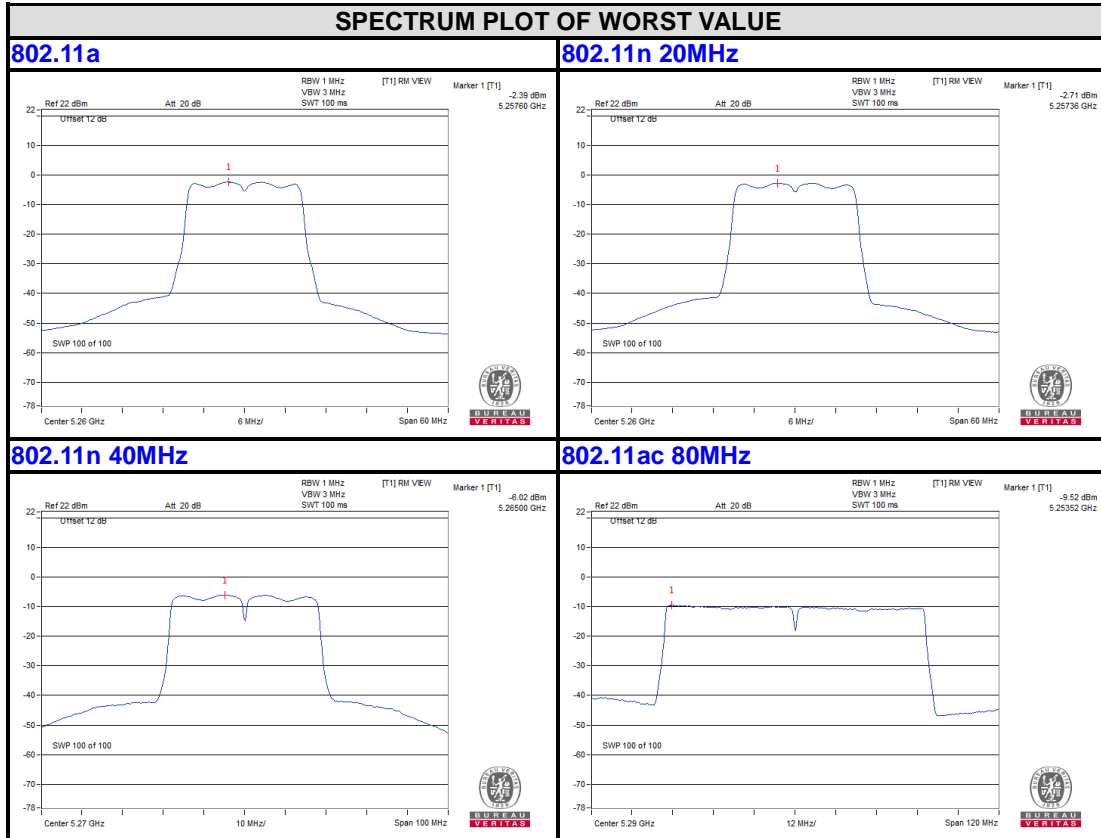

Bureau Veritas Shenzhen Co., Ltd.  
Dongguan Branch

No. 34, Chenwulu Section, Guantai Rd., Houjie  
Town, Dongguan City,  
Guangdong 523942, China

Tel: +86 769 8593 5656  
Fax: +86 769 8593 1080  
Email: [customerservice.dg@cn.bureauveritas.com](mailto:customerservice.dg@cn.bureauveritas.com)



**BUREAU  
VERITAS**

Test Report No.: RF160712N001-3

BAND 3  
5470-5725MHz

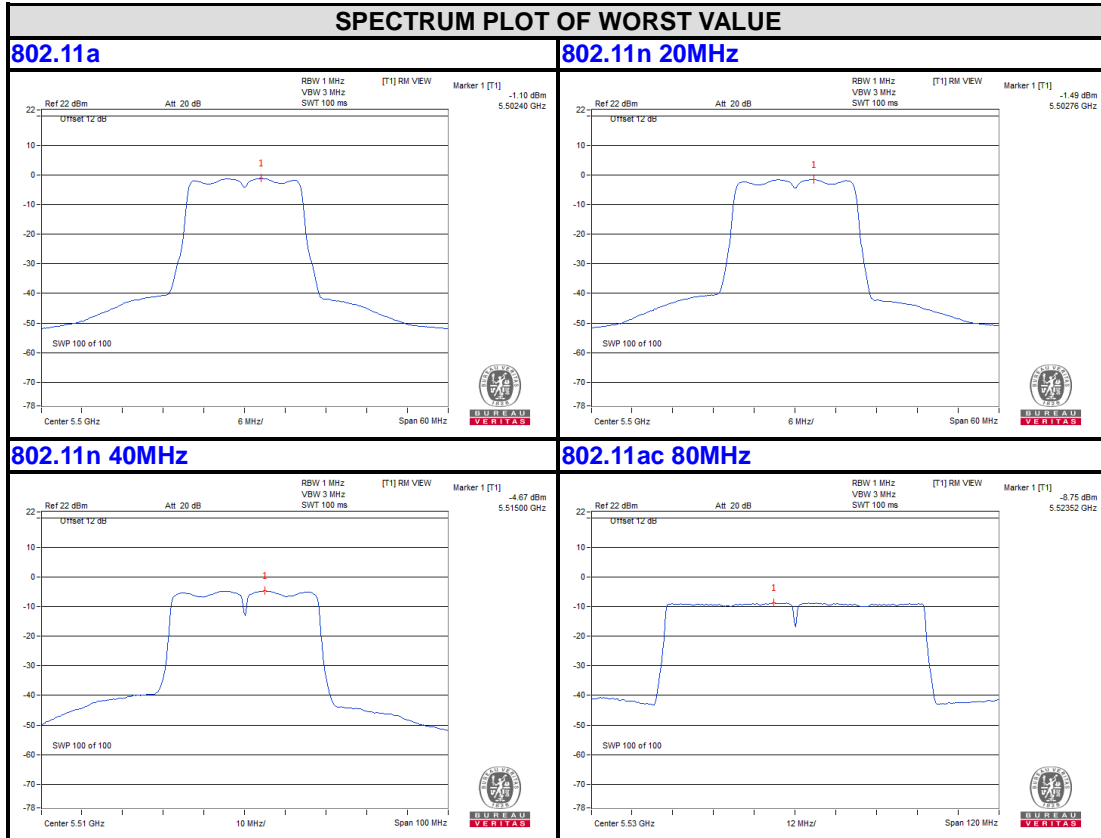

Bureau Veritas Shenzhen Co., Ltd.  
Dongguan Branch

No. 34, Chenwulu Section, Guantai Rd., Houjie  
Town, Dongguan City,  
Guangdong 523942, China

Tel: +86 769 8593 5656  
Fax: +86 769 8593 1080  
Email: [customerservice.dg@cn.bureauveritas.com](mailto:customerservice.dg@cn.bureauveritas.com)



**BUREAU  
VERITAS**

Test Report No.: RF160712N001-3

BAND4  
5725-5850MHz

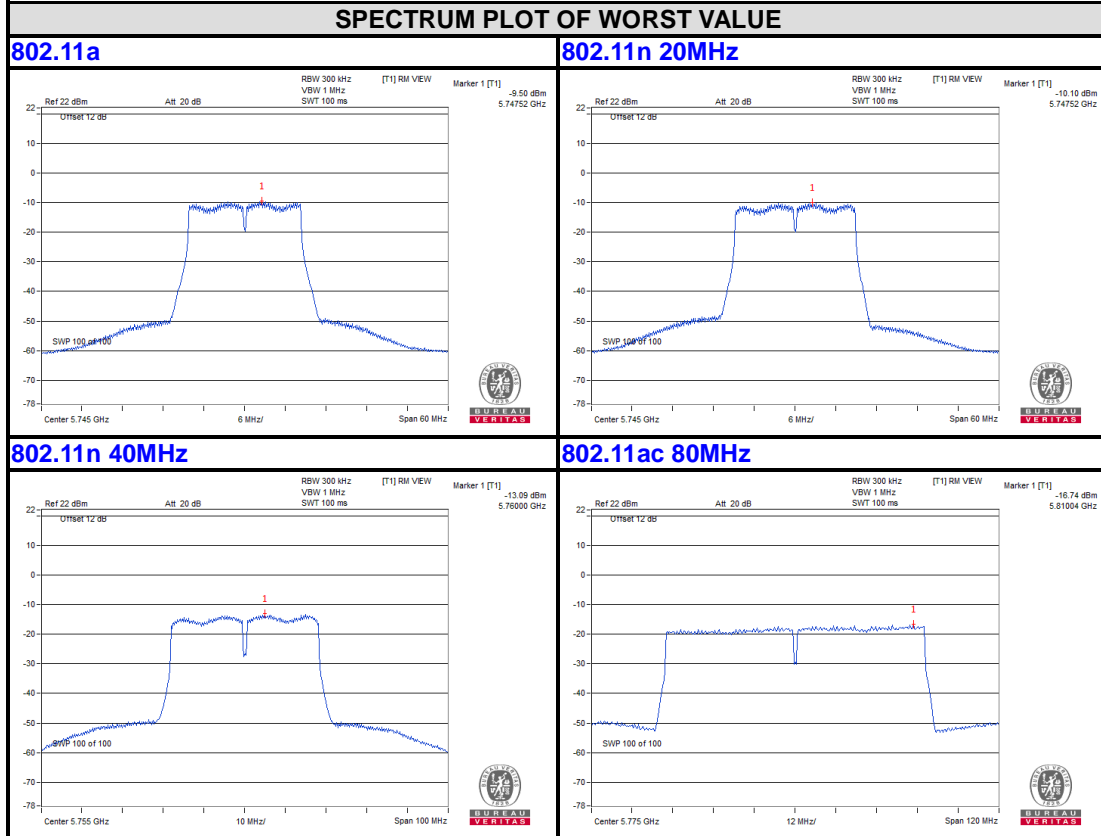



### 3.5 FREQUENCY STABILITY

#### 3.5.1 LIMITS OF FREQUENCY STABILITY MEASUREMENT

The frequency of the carrier signal shall be maintained within band of operation.

#### 3.5.2 TEST SETUP

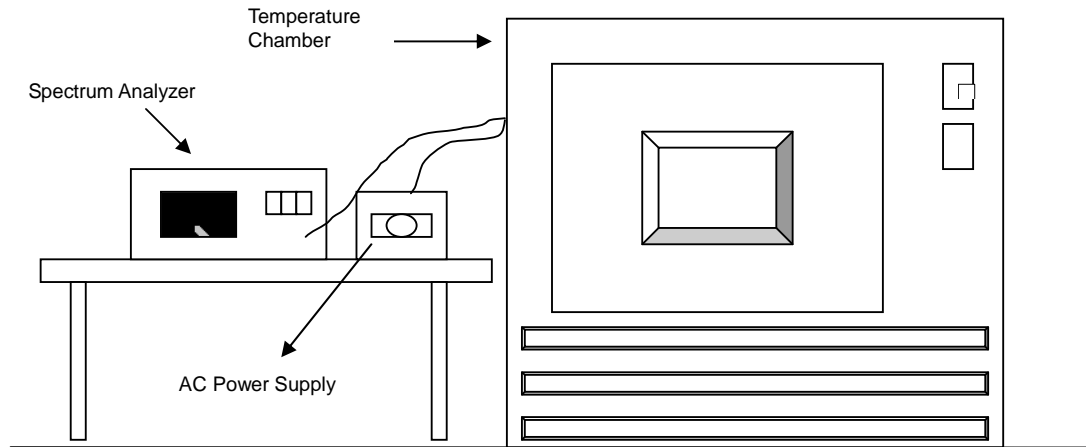

#### 3.5.3 TEST INSTRUMENTS

Refer to section 3.3.3 to get information of above instrument.



### 3.5.4 TEST PROCEDURE

- a. The EUT was placed inside the environmental test chamber and powered by nominal AC voltage.
- b. Turn the EUT on and couple its output to a spectrum analyzer.
- c. Turn the EUT off and set the chamber to the highest temperature specified.
- d. Allow sufficient time (approximately 30 min) for the temperature of the chamber to stabilize, turn the EUT on and measure the operating frequency after 2, 5, and 10 minutes.
- e. Repeat step 2 and 3 with the temperature chamber set to the lowest temperature.
- f. The test chamber was allowed to stabilize at +20 degree C for a minimum of 30 minutes. The supply voltage was then adjusted on the EUT from 85% to 115% and the frequency record.

### 3.5.5 DEVIATION FROM TEST STANDARD

No deviation.

### 3.5.6 EUT OPERATING CONDITION

Set the EUT transmit at un-modulation mode to test frequency stability.



3.5.7 TEST RESULTS

FREQUENCY STABILITY VERSUS TEMP.									
OPERATING FREQUENCY: 5180MHz									
TEMP. (°C)	POWER SUPPLY (Vac)	0 MINUTE		2 MINUTE		5 MINUTE		10 MINUTE	
		Measured Frequency (MHz)	Frequency Drift	Measured Frequency (MHz)	Frequency Drift	Measured Frequency (MHz)	Frequency Drift	Measured Frequency (MHz)	Frequency Drift
50	120	5179.9836	-0.00032	5179.9814	-0.00036	5179.9823	-0.00034	5179.9794	-0.00040
40	120	5180.0175	0.00034	5180.0187	0.00036	5180.0155	0.00030	5180.0179	0.00035
30	120	5180.0062	0.00012	5180.0059	0.00011	5180.0058	0.00011	5180.0097	0.00019
20	120	5180.0205	0.00040	5180.0214	0.00041	5180.0226	0.00044	5180.0251	0.00048
10	120	5180.0119	0.00023	5180.0102	0.00020	5180.0125	0.00024	5180.0124	0.00024
0	120	5180.0151	0.00029	5180.0118	0.00023	5180.0141	0.00027	5180.0144	0.00028
-10	120	5179.9893	-0.00021	5179.9885	-0.00022	5179.987	-0.00025	5179.9886	-0.00022
-20	120	5180.0215	0.00042	5180.0192	0.00037	5180.0232	0.00045	5180.0224	0.00043
-30	120	5179.992	-0.00015	5179.9943	-0.00011	5179.9898	-0.00020	5179.9949	-0.00010

FREQUENCY STABILITY VERSUS TEMP.									
OPERATING FREQUENCY: 5180MHz									
TEMP. (°C)	POWER SUPPLY (Vac)	0 MINUTE		2 MINUTE		5 MINUTE		10 MINUTE	
		Measured Frequency (MHz)	Frequency Drift	Measured Frequency (MHz)	Frequency Drift	Measured Frequency (MHz)	Frequency Drift	Measured Frequency (MHz)	Frequency Drift
20	138	5180.0211	0.00041	5180.022	0.00042	5180.0218	0.00042	5180.0244	0.00047
	120	5180.0205	0.00040	5180.0214	0.00041	5180.0226	0.00044	5180.0251	0.00048
	102	5180.0199	0.00038	5180.0214	0.00041	5180.0217	0.00042	5180.0259	0.00050



**BUREAU  
VERITAS**

Test Report No.: RF160712N001-3

#### **4. PHOTOGRAPHS OF THE TEST CONFIGURATION**

Please refer to the attached file (Test Setup Photo).



Test Report No.: RF160712N001-3

## 5. APPENDIX A – MODIFICATIONS RECORDERS FOR ENGINEERING CHANGES TO THE EUT BY THE LAB

No modifications were made to the EUT by the lab during the test.

---END---