



FCC RADIO TEST REPORT-BT 4.0

FCC ID: APIJBLFLIP3

Product : Portable speaker with Bluetooth

Trade Name : N/A

Model Name : FLIP 3

Serial Model : N/A

Report No. : NTEK-2015DC0105008F2

Prepared for

Harman International Industries, Incorporated
8500 Balboa Blvd, Northridge, CA 91329, United States

Prepared by

Shenzhen NTEK Testing Technology Co., Ltd.
1/F, Building E, Fenda Science Park, Sanwei Community, Xixiang Street
Bao'an District, Shenzhen P.R. China
Tel.: +86-0755-61156588 Fax.: +86-0755-61156599
Website:www.ntek.org.cn

TEST RESULT CERTIFICATION

Applicant's name Harman International Industries, Incorporated
Address 8500 Balboa Blvd, Northridge, CA 91329, United States
Manufacturer's Name... Harman International Industries, Incorporated
Address 8500 Balboa Blvd, Northridge, CA 91329, United States

Product description

Product name Portable speaker with Bluetooth
Model and/or type FLIP 3
reference
Serial Model N/A

Standards FCC Part15.247: 01 Oct. 2014

Test procedure ANSI C63.4-2003

This device described above has been tested by NTEK, and the test results show that the equipment under test (EUT) is in compliance with the Industry Canada requirements. And it is applicable only to the tested sample identified in the report.

This report shall not be reproduced except in full, without the written approval of NTEK, this document may be altered or revised by NTEK, personal only, and shall be noted in the revision of the document.

Date of Test

Date (s) of performance of tests : 05 Jan. 2015 ~20 Jan. 2015

Date of Issue : 20 Jan. 2015

Test Result : **Pass**

Testing Engineer : Jason Chen
(Jason Chen)

Technical Manager : Brown Lu
(Brown Lu)

Authorized Signatory : Bill Yao
(Bill Yao)

Table of Contents

| | Page |
|---|-------------|
| 1 . SUMMARY OF TEST RESULTS | 5 |
| 1.1 TEST FACILITY | 6 |
| 1.2 MEASUREMENT UNCERTAINTY | 6 |
| 2 . GENERAL INFORMATION | 7 |
| 2.1 GENERAL DESCRIPTION OF EUT | 7 |
| 2.2 DESCRIPTION OF TEST MODES | 9 |
| 2.3 BLOCK DIGRAM SHOWING THE CONFIGURATION OF SYSTEM TESTED | 10 |
| 2.4 DESCRIPTION OF SUPPORT UNITS(CONDUCTED MODE) | 11 |
| 2.5 EQUIPMENTS LIST FOR ALL TEST ITEMS | 12 |
| 3 . EMC EMISSION TEST | 13 |
| 3.1 CONDUCTED EMISSION MEASUREMENT | 13 |
| 3.1.1 POWER LINE CONDUCTED EMISSION LIMITS | 13 |
| 3.1.2 TEST PROCEDURE | 14 |
| 3.1.3 DEVIATION FROM TEST STANDARD | 14 |
| 3.1.4 TEST SETUP | 14 |
| 3.1.5 EUT OPERATING CONDITIONS | 14 |
| 3.1.6 TEST RESULTS | 15 |
| 3.2 RADIATED EMISSION MEASUREMENT | 17 |
| 3.2.1 RADIATED EMISSION LIMITS | 17 |
| 3.2.2 TEST PROCEDURE | 18 |
| 3.2.3 DEVIATION FROM TEST STANDARD | 18 |
| 3.2.4 TEST SETUP | 19 |
| 3.2.5 EUT OPERATING CONDITIONS | 20 |
| 3.2.6 TEST RESULTS (BETWEEN 9KHZ – 30 MHZ) | 21 |
| 3.2.7 TEST RESULTS (BETWEEN 30MHZ – 1GHZ) | 22 |
| 3.2.8 TEST RESULTS (ABOVE 1000 MHZ) | 24 |
| 4 . POWER SPECTRAL DENSITY TEST | 25 |
| 4.1 APPLIED PROCEDURES / LIMIT | 25 |
| 4.1.1 TEST PROCEDURE | 25 |
| 4.1.2 DEVIATION FROM STANDARD | 25 |
| 4.1.3 TEST SETUP | 25 |
| 4.1.4 EUT OPERATION CONDITIONS | 25 |
| 4.1.5 TEST RESULTS | 26 |
| 5 . BANDWIDTH TEST | 28 |
| 5.1 APPLIED PROCEDURES / LIMIT | 28 |
| 5.1.1 TEST PROCEDURE | 28 |

Table of Contents

| | Page |
|---|-------------------|
| TEST SETUP | 28 |
| 5.1.2 EUT OPERATION CONDITIONS | 28 |
| 5.1.3 TEST RESULTS | 29 |
| 6 . PEAK OUTPUT POWER TEST | 31 |
| 6.1 APPLIED PROCEDURES / LIMIT | 31 |
| 6.1.1 TEST PROCEDURE | 31 |
| 6.1.2 DEVIATION FROM STANDARD | 31 |
| 6.1.3 TEST SETUP | 31 |
| 6.1.4 EUT OPERATION CONDITIONS | 31 |
| 6.1.5 TEST RESULTS | 32 |
| 7 . 100 KHZ BANDWIDTH OF FREQUENCY BAND EDGE | 33 |
| 7.1 DEVIATION FROM STANDARD | 33 |
| 7.2 TEST SETUP | 33 |
| 7.3 EUT OPERATION CONDITIONS | 33 |
| 7.4 TEST RESULTS | 34 |
| 8 . EUT TEST PHOTO | 错误! 未定义书签。 |
| APPENDIX-PHOTOGRAPHS OF EUT CONSTRUCTIONAL DETAILS | |

1. SUMMARY OF TEST RESULTS

Test procedures according to the technical standards:

| FCC Part15 (15.247) , Subpart C | | | |
|---------------------------------|----------------------------|----------|--------|
| Standard Section | Test Item | Judgment | Remark |
| 15.207 | Conducted Emission | PASS | |
| 15.247 (a)(2) | 6dB Bandwidth | PASS | |
| 15.247 (b) | Peak Output Power | PASS | |
| 15.247 (c) | Radiated Spurious Emission | PASS | |
| 15.247 (d) | Power Spectral Density | PASS | |
| 15.205 | Band Edge Emission | PASS | |
| 15.203 | Antenna Requirement | PASS | |

NOTE:

(1) "N/A" denotes test is not applicable in this Test Report

1.1 TEST FACILITY

NTEK Testing Technology Co., Ltd
 Add.:1/F, Building E, Fenda Science Park, Sanwei Community, Xixiang Street, Bao'an District, Shenzhen P.R. China.
 FCC Registration No.:238937; IC Registration No.:9270A-1
 CNAS Registration No.:L5516

1.2 MEASUREMENT UNCERTAINTY

The reported uncertainty of measurement $y \pm U$, where expanded uncertainty U is based on a standard uncertainty multiplied by a coverage factor of $k=2$, providing a level of confidence of approximately 95 %.

| No. | Item | Uncertainty |
|-----|------------------------------|-------------------------|
| 1 | Conducted Emission Test | $\pm 1.38\text{dB}$ |
| 2 | RF power,conducted | $\pm 0.16\text{dB}$ |
| 3 | Spurious emissions,conducted | $\pm 0.21\text{dB}$ |
| 4 | All emissions,radiated(<1G) | $\pm 4.68\text{dB}$ |
| 5 | All emissions,radiated(>1G) | $\pm 4.89\text{dB}$ |
| 6 | Temperature | $\pm 0.5^\circ\text{C}$ |
| 7 | Humidity | $\pm 2\%$ |

2. GENERAL INFORMATION

2.1 GENERAL DESCRIPTION OF EUT

| | | |
|------------------------|--|--------------------|
| Equipment | Portable speaker with Bluetooth | |
| Trade Name | N/A | |
| Model Name | FLIP 3 | |
| Serial Model | N/A | |
| Model Difference | N/A | |
| Product Description | The EUT is a Portable speaker with Bluetooth | |
| | Operation Frequency: | 2402~2480MHz |
| | Modulation Type: | GFSK |
| | Number Of Channel | 40CH |
| | Antenna Designation: | Please see Note 3. |
| | Antenna Gain (dBi) | 2.87dBi |
| | Based on the application, features, or specification exhibited in User's Manual, the EUT is considered as an ITE/Computing Device. More details of EUT technical specification, please refer to the User's Manual. | |
| Channel List | Please refer to the Note 2. | |
| Ratings | DC 3.7V | |
| Battery | DC 3.7V ,3000mAh | |
| Connecting I/O Port(s) | Please refer to the User's Manual | |

Note:

1. For a more detailed features description, please refer to the manufacturer's specifications or the User's Manual.

2.

| Channel | Frequency (MHz) |
|---------|-----------------|
| 00 | 2402 |
| 01 | 2404 |
| | |
| | |
| ... | ... |
| | |
| 38 | 2478 |
| 39 | 2480 |

3.

Table for Filed Antenna

| Ant | Brand | Model Name | Antenna Type | Connector | Gain (dBi) | NOTE |
|-----|-------|------------|--------------|-----------|------------|------------|
| A | N/A | N/A | FPCB Antenna | N/A | 2.87 | BT Antenna |

2.2 DESCRIPTION OF TEST MODES

To investigate the maximum EMI emission characteristics generates from EUT, the test system was pre-scanning tested base on the consideration of following EUT operation mode or test configuration mode which possible have effect on EMI emission level. Each of these EUT operation mode(s) or test configuration mode(s) mentioned above was evaluated respectively.

| Pretest Mode | Description |
|--------------|-------------|
| Mode 1 | CH00 |
| Mode 2 | CH19 |
| Mode 3 | CH39 |
| Mode 4 | Link Mode |

| For Conducted Emission | |
|------------------------|-------------|
| Final Test Mode | Description |
| Mode 4 | Link Mode |

| For Radiated Emission | |
|-----------------------|-------------|
| Final Test Mode | Description |
| Mode 1 | CH00 |
| Mode 2 | CH19 |
| Mode 3 | CH39 |
| Mode 4 | Link Mode |

Note:

- (1) The measurements are performed at the highest, middle, lowest available channels.
- (2) The measurements are performed at all Bit Rate of Transmitter, the worst data was reported

2.3 BLOCK DIGRAM SHOWING THE CONFIGURATION OF SYSTEM TESTED

Conducted Emission Test

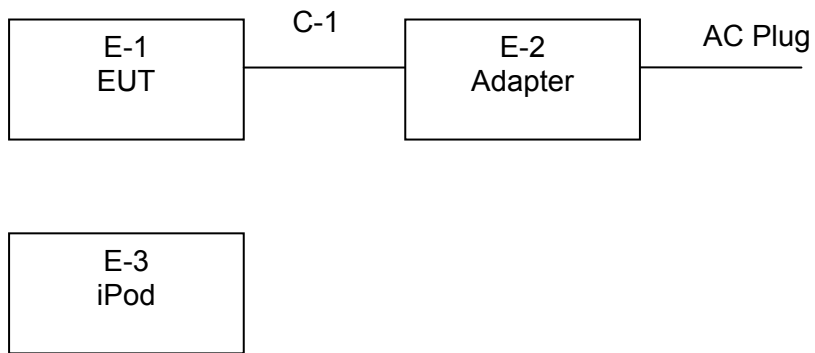

Radiated Spurious Emission Test

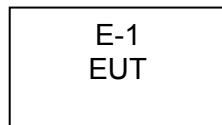

2.4 DESCRIPTION OF SUPPORT UNITS(CONDUCTED MODE)

The EUT has been tested as an independent unit together with other necessary accessories or support units. The following support units or accessories were used to form a representative test configuration during the tests.

| Item | Equipment | Brand | Model/Type No. | Series No. | Note |
|------|---------------------------------|--------|----------------|------------|------|
| E-1 | Portable speaker with Bluetooth | N/A | FLIP 3 | N/A | EUT |
| E-2 | ADAPTER | Harman | F5V-2.3C-1U | N/A | |
| E-3 | iPod | Apple | MGG82CHA | N/A | |
| | | | | | |
| | | | | | |
| | | | | | |

| Item | Shielded Type | Ferrite Core | Length | Note |
|------|---------------|--------------|--------|-----------|
| C-1 | NO | NO | 1.2m | USB Cable |
| | | | | |
| | | | | |
| | | | | |
| | | | | |

Note:

- (1) The support equipment was authorized by Declaration of Confirmation.
- (2) For detachable type I/O cable should be specified the length in cm in 『Length』 column.

2.5 EQUIPMENTS LIST FOR ALL TEST ITEMS

Radiation Test equipment

| Item | Kind of Equipment | Manufacturer | Type No. | Serial No. | Last calibration | Calibrated until | Calibration period |
|------|--------------------|--------------|-------------|--------------|------------------|------------------|--------------------|
| 1 | Spectrum Analyzer | Agilent | E4407B | MY45108040 | 2014.07.06 | 2015.07.05 | 1 year |
| 2 | Test Receiver | R&S | ESPI | 101318 | 2014.06.07 | 2015.06.06 | 1 year |
| 3 | Bilog Antenna | TESEQ | CBL6111D | 31216 | 2014.07.06 | 2015.07.05 | 1 year |
| 4 | 50Ω Coaxial Switch | Anritsu | MP59B | 6200264416 | 2014.06.07 | 2015.06.06 | 1 year |
| 5 | Spectrum Analyzer | ADVANTEST | R3132 | 150900201 | 2014.06.07 | 2015.06.06 | 1 year |
| 6 | Horn Antenna | EM | EM-AH-10180 | 2011071402 | 2014.07.06 | 2015.07.05 | 1 year |
| 7 | Horn Ant | Schwarzbeck | BBHA 9170 | 9170-181 | 2014.07.06 | 2015.07.05 | 1 year |
| 8 | Amplifier | EM | EM-30180 | 060538 | 2013.12.22 | 2014.12.21 | 1 year |
| 9 | Loop Antenna | ARA | PLA-1030/B | 1029 | 2014.06.08 | 2015.06.07 | 1 year |
| 10 | Power Meter | R&S | NRVS | 100696 | 2014.07.06 | 2015.07.05 | 1 year |
| 11 | Power Sensor | R&S | URV5-Z4 | 0395.1619.05 | 2014.07.06 | 2015.07.05 | 1 year |

Conduction Test equipment

| Item | Kind of Equipment | Manufacturer | Type No. | Serial No. | Last calibration | Calibrated until | Calibration period |
|------|-----------------------|--------------|----------|------------|------------------|------------------|--------------------|
| 1 | Test Receiver | R&S | ESCI | 101160 | 2014.06.06 | 2015.06.05 | 1 year |
| 2 | LISN | R&S | ENV216 | 101313 | 2014.08.24 | 2015.08.23 | 1 year |
| 3 | LISN | EMCO | 3816/2 | 00042990 | 2014.08.24 | 2015.08.23 | 1 year |
| 4 | 50Ω Coaxial Switch | Anritsu | MP59B | 6200264417 | 2014.06.07 | 2015.06.06 | 1 year |
| 5 | Passive Voltage Probe | R&S | ESH2-Z3 | 100196 | 2014.06.07 | 2015.06.06 | 1 year |
| 6 | Absorbing clamp | R&S | MOS-21 | 100423 | 2014.06.08 | 2015.06.07 | 1 year |

| | | | | | | | |
|---|-------------|-----|----------|--------|------------|------------|--------|
| 1 | Attenuation | MCE | 24-10-34 | BN9258 | 2014.06.08 | 2015.06.07 | 1 year |
|---|-------------|-----|----------|--------|------------|------------|--------|

3. EMC EMISSION TEST

3.1 CONDUCTED EMISSION MEASUREMENT

3.1.1 POWER LINE CONDUCTED EMISSION Limits (Frequency Range 150KHz-30MHz)

| FREQUENCY (MHz) | Class A (dBuV) | | Class B (dBuV) | | Standard |
|-----------------|----------------|---------|----------------|-----------|----------|
| | Quasi-peak | Average | Quasi-peak | Average | |
| 0.15 -0.5 | 79.00 | 66.00 | 66 - 56 * | 56 - 46 * | CISPR |
| 0.50 -5.0 | 73.00 | 60.00 | 56.00 | 46.00 | CISPR |
| 5.0 -30.0 | 73.00 | 60.00 | 60.00 | 50.00 | CISPR |

| | | | | | |
|-----------|-------|-------|-----------|-----------|---------|
| 0.15 -0.5 | 79.00 | 66.00 | 66 - 56 * | 56 - 46 * | RSS-210 |
| 0.50 -5.0 | 73.00 | 60.00 | 56.00 | 46.00 | RSS-210 |
| 5.0 -30.0 | 73.00 | 60.00 | 60.00 | 50.00 | RSS-210 |

Note:

- (1) The tighter limit applies at the band edges.
- (2) The limit of " * " marked band means the limitation decreases linearly with the logarithm of the frequency in the range.

The following table is the setting of the receiver

| Receiver Parameters | Setting |
|---------------------|----------|
| Attenuation | 10 dB |
| Start Frequency | 0.15 MHz |
| Stop Frequency | 30 MHz |
| IF Bandwidth | 9 kHz |

3.1.2 TEST PROCEDURE

- a. The EUT was placed 0.8 meters from the horizontal ground plane with EUT being connected to the power mains through a line impedance stabilization network (LISN). All other support equipments powered from additional LISN(s). The LISN provide 50 Ohm/ 50uH of coupling impedance for the measuring instrument.
- b. Interconnecting cables that hang closer than 40 cm to the ground plane shall be folded back and forth in the center forming a bundle 30 to 40 cm long.
- c. I/O cables that are not connected to a peripheral shall be bundled in the center. The end of the cable may be terminated, if required, using the correct terminating impedance. The overall length shall not exceed 1 m.
- d. LISN at least 80 cm from nearest part of EUT chassis.
- e. For the actual test configuration, please refer to the related Item –EUT Test Photos.

3.1.3 DEVIATION FROM TEST STANDARD

No deviation

3.1.4 TEST SETUP

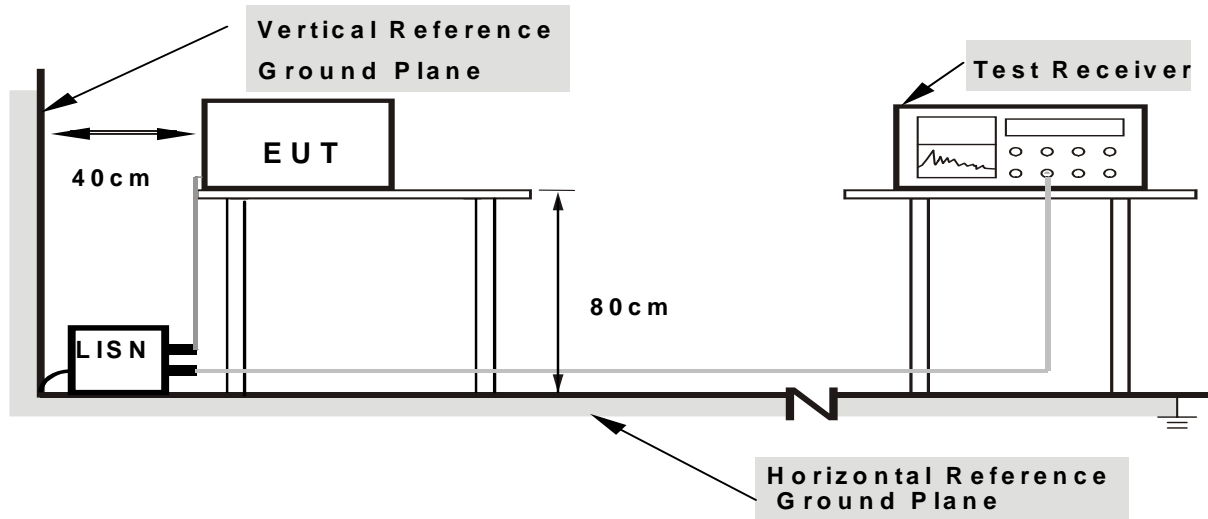

- Note:**
- 1. Support units were connected to second LISN.
 - 2. Both of LISNs (AMN) are 80 cm from EUT and at least 80 from other units and other metal planes

3.1.5 EUT OPERATING CONDITIONS

The EUT was configured for testing in a typical fashion (as a customer would normally use it). The EUT has been programmed to continuously transmit during test. This operating condition was tested and used to collect the included data.

3.1.6 TEST RESULTS

| | | | |
|----------------|--------------------------------------|---------------------|--------|
| EUT : | Portable speaker with Bluetooth | Model Name. : | FLIP 3 |
| Temperature : | 26 °C | Relative Humidity : | 56% |
| Pressure : | 1010hPa | Phase : | L |
| Test Voltage : | DC 5.0V form Adapter AC 120V/60Hz | Test Mode : | Mode 4 |

| Frequency (MHz) | Meter Reading (dBμV) | Factor (dB) | Emission Level (dBμV) | Limits (dBμV) | Margin (dB) | Remark |
|--------------------|-------------------------|----------------|--------------------------|------------------|----------------|--------|
| 0.4300 | 41.89 | 9.46 | 51.35 | 57.25 | -5.90 | QP |
| 0.4300 | 28.50 | 9.46 | 37.96 | 47.25 | -9.29 | AVG |
| 0.8380 | 37.27 | 9.45 | 46.72 | 56.00 | -9.28 | QP |
| 2.1220 | 37.35 | 9.46 | 46.81 | 56.00 | -9.19 | QP |
| 2.2700 | 24.98 | 9.45 | 34.43 | 46.00 | -11.57 | AVG |
| 8.9420 | 44.36 | 9.56 | 53.92 | 60.00 | -6.08 | QP |
| 9.0260 | 30.47 | 9.57 | 40.04 | 50.00 | -9.96 | AVG |

Remark:

1. All readings are Quasi-Peak and Average values.
2. Factor = Insertion Loss + Cable Loss.

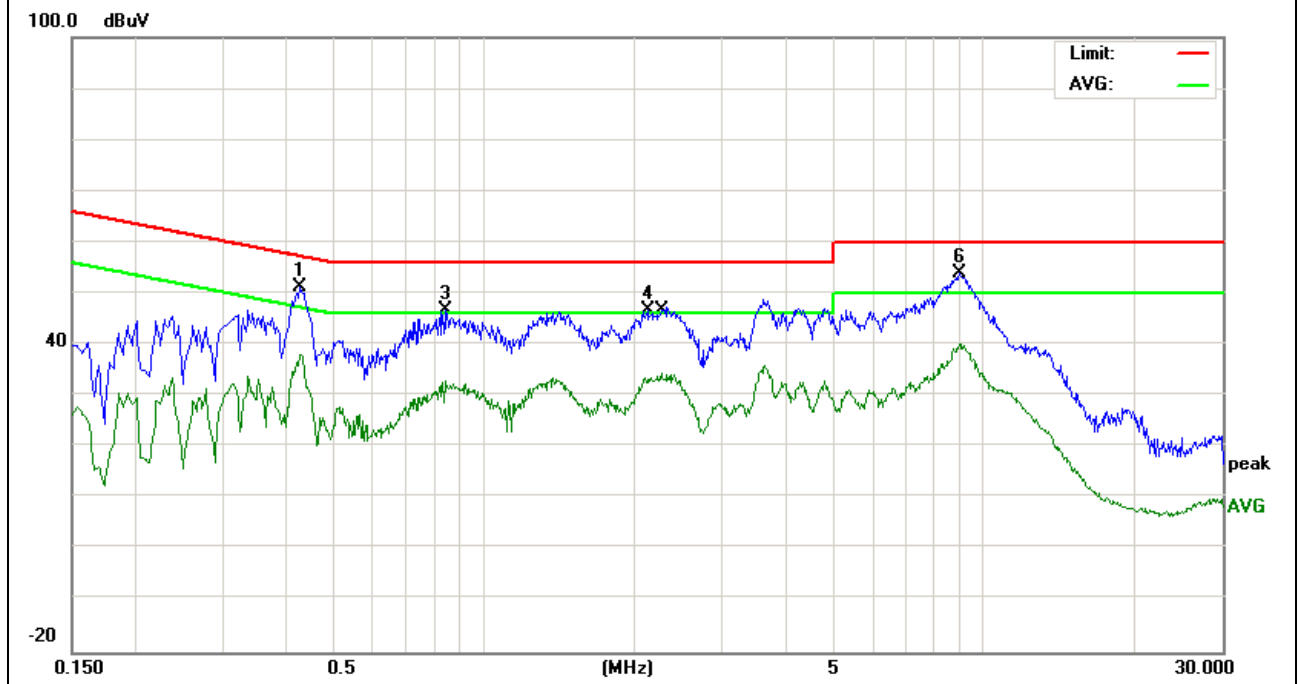

| | | | |
|----------------|--------------------------------------|---------------------|--------|
| EUT : | Portable speaker with Bluetooth | Model Name. : | FLIP 3 |
| Temperature : | 26 °C | Relative Humidity : | 56% |
| Pressure : | 1010hPa | Phase : | N |
| Test Voltage : | DC 5.0V form Adapter AC 120V/60Hz | Test Mode : | Mode 4 |

| Frequency (MHz) | Meter Reading (dBμV) | Factor (dB) | Emission Level (dBμV) | Limits (dBμV) | Margin (dB) | Remark |
|--------------------|-------------------------|----------------|--------------------------|------------------|----------------|--------|
| 8.8979 | 40.87 | 9.56 | 50.43 | 60.00 | -9.57 | QP |
| 4.4540 | 35.78 | 9.44 | 45.22 | 56.00 | -10.78 | QP |
| 2.0380 | 36.65 | 9.46 | 46.11 | 56.00 | -9.89 | QP |
| 2.0900 | 21.04 | 9.46 | 30.50 | 46.00 | -15.50 | AVG |
| 4.4180 | 19.43 | 9.44 | 28.87 | 46.00 | -17.13 | AVG |
| 8.9819 | 23.31 | 9.56 | 32.87 | 50.00 | -17.13 | AVG |

Remark:
 1. All readings are Quasi-Peak and Average values.
 2. Factor = Insertion Loss + Cable Loss.

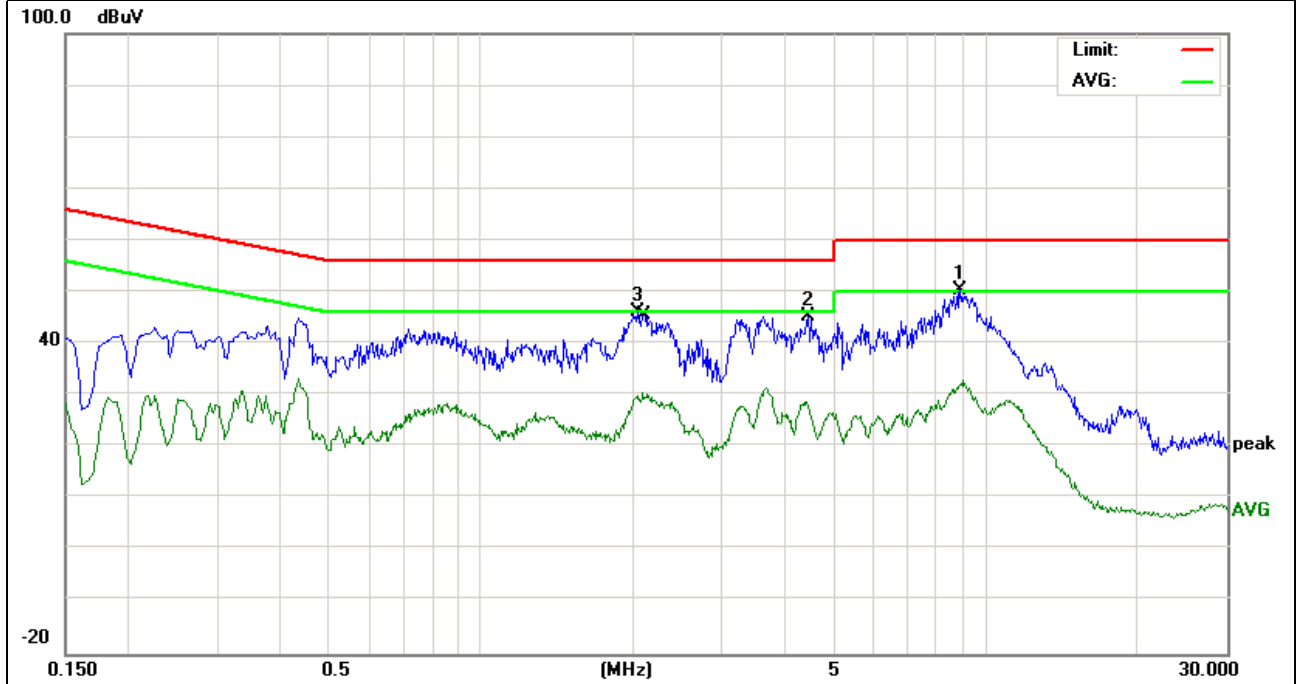

3.2 RADIATED EMISSION MEASUREMENT

3.2.1 RADIATED EMISSION LIMITS (Frequency Range 9kHz-1000MHz)

20dBc in any 100 kHz bandwidth outside the operating frequency band. In case the emission fall within the restricted band specified on 15.205(a), then the 15.209(a) limit in the table below has to be followed.

| Frequencies (MHz) | Field Strength (microrvolts/meter) | Measurement Distance (meters) |
|-------------------|------------------------------------|-------------------------------|
| 0.009~0.490 | 2400/F(KHz) | 300 |
| 0.490~1.705 | 24000/F(KHz) | 30 |
| 1.705~30.0 | 30 | 30 |
| 30~88 | 100 | 3 |
| 88~216 | 150 | 3 |
| 216~960 | 200 | 3 |
| Above 960 | 500 | 3 |

LIMITS OF RADIATED EMISSION MEASUREMENT (Above 1000MHz)

| FREQUENCY (MHz) | Class B (dBuV/m) (at 3M) | |
|-----------------|--------------------------|---------|
| | PEAK | AVERAGE |
| Above 1000 | 74 | 54 |

Notes:

- (1) The limit for radiated test was performed according to RSS-Gen.
- (2) The tighter limit applies at the band edges.
- (3) Emission level (dBuV/m)=20log Emission level (uV/m).

| Spectrum Parameter | Setting |
|---------------------------------------|--|
| Attenuation | Auto |
| Start Frequency | 1000 MHz |
| Stop Frequency | 10th carrier harmonic |
| RB / VB (emission in restricted band) | 1 MHz / 1 MHz for Peak, 1 MHz / 10Hz for Average |

| Receiver Parameter | Setting |
|------------------------|----------------------------------|
| Attenuation | Auto |
| Start ~ Stop Frequency | 9kHz~150kHz / RB 200Hz for QP |
| Start ~ Stop Frequency | 150kHz~30MHz / RB 9kHz for QP |
| Start ~ Stop Frequency | 30MHz~1000MHz / RB 120kHz for QP |

3.2.2 TEST PROCEDURE

- a. The measuring distance of at 3 m shall be used for measurements at frequency up to 1GHz. For frequencies above 1GHz, any suitable measuring distance may be used.
- b. The EUT was placed on the top of a rotating table 0.8 meters above the ground at a 3 meter test site. The table was rotated 360 degrees to determine the position of the highest radiation.
- c. The height of the equipment or of the substitution antenna shall be 0.8 m; the height of the test antenna shall vary between 1 m to 4 m. Both horizontal and vertical polarizations of the antenna are set to make the measurement.
- d. The initial step in collecting conducted emission data is a spectrum analyzer peak detector mode pre-scanning the measurement frequency range. Significant peaks are then marked and then Quasi Peak detector mode re-measured.
- e. If the Peak Mode measured value compliance with and lower than Quasi Peak Mode Limit, the EUT shall be deemed to meet QP Limits and then no additional QP Mode measurement performed.
- f. For the actual test configuration, please refer to the related Item –EUT Test Photos.

Note:

Both horizontal and vertical antenna polarities were tested and performed pretest to three orthogonal axis. The worst case emissions were reported

During the radiated emission test, the Spectrum Analyzer was set with the following configurations:

| Frequency Band (MHz) | Function | Resolution bandwidth | Video Bandwidth |
|----------------------|----------|----------------------|-----------------|
| 30 to 1000 | QP | 120 kHz | 300 kHz |
| Above 1000 | Peak | 1 MHz | 1 MHz |
| | Peak | 1 MHz | 10 Hz |

3.2.3 DEVIATION FROM TEST STANDARD

No deviation

3.2.4 TEST SETUP

(A) Radiated Emission Test-Up Frequency Below 30MHz

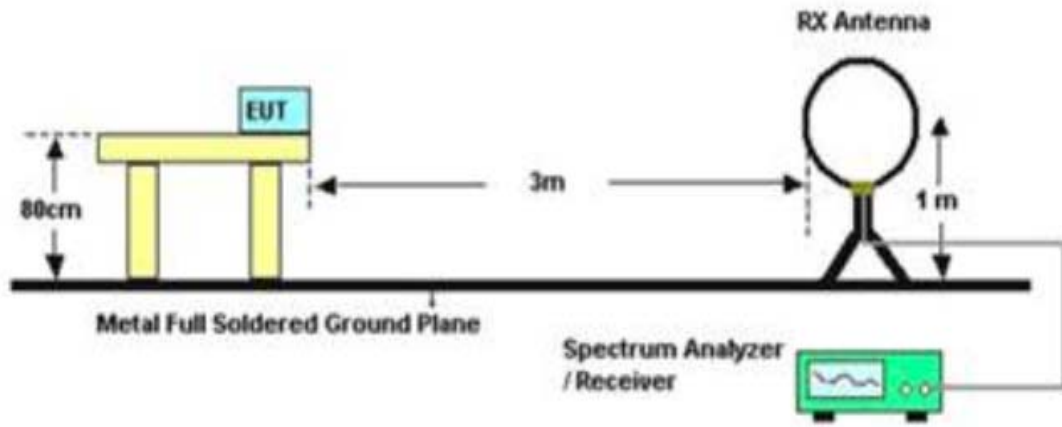

(B) Radiated Emission Test-Up Frequency 30MHz~1GHz

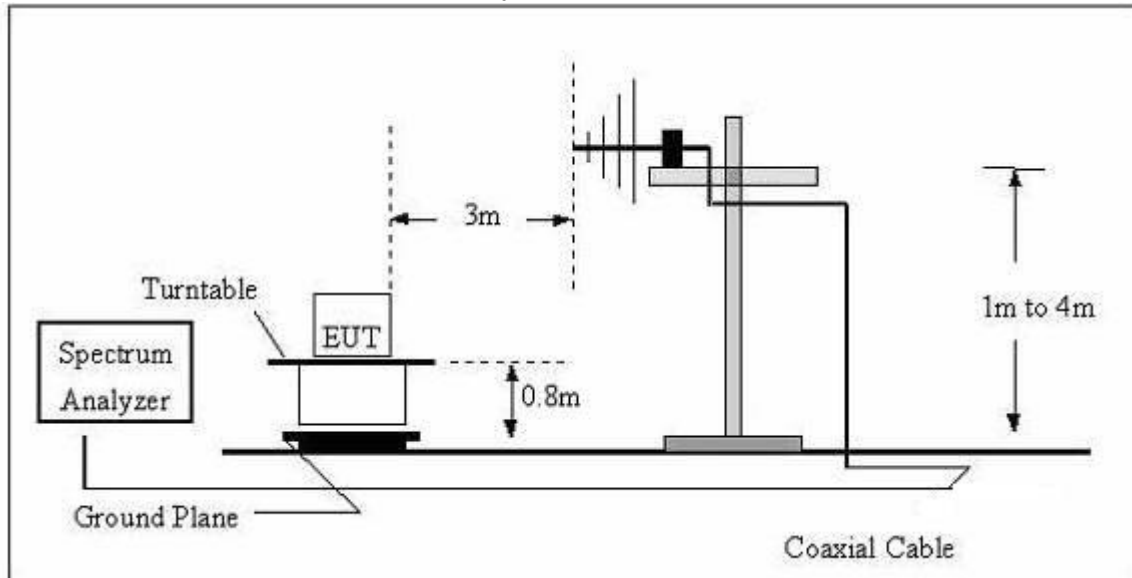

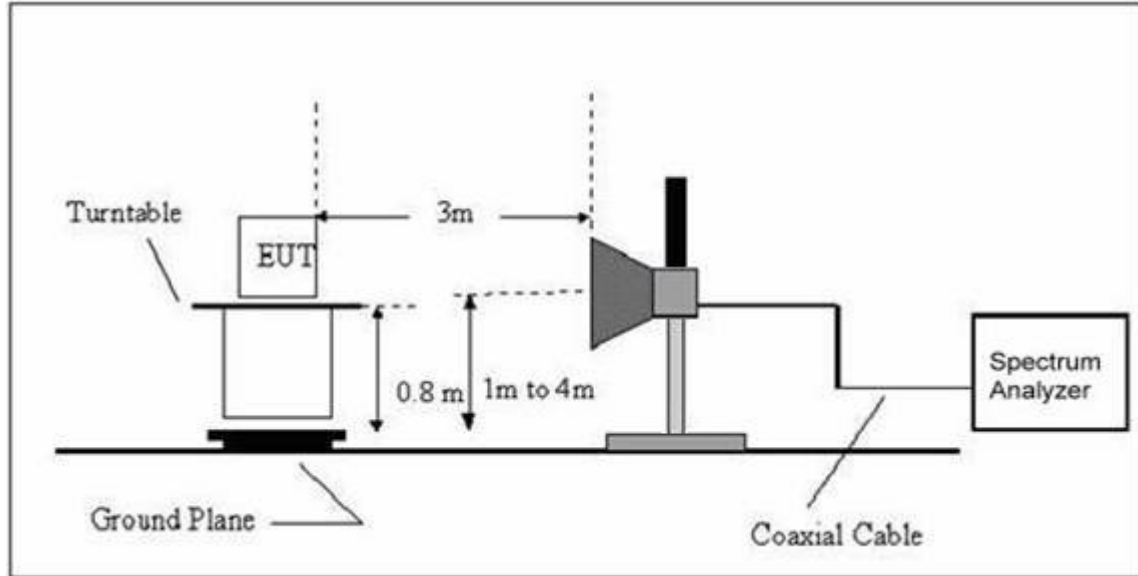
(C) Radiated Emission Test-Up Frequency Above 1GHz**3.2.5 EUT OPERATING CONDITIONS**

The EUT tested system was configured as the statements of 2.4 Unless otherwise a special operating condition is specified in the follows during the testing.

3.2.6 TEST RESULTS (BETWEEN 9KHZ – 30 MHZ)

| | | | |
|--------------|---------------------------------|--------------------|---------|
| EUT: | Portable speaker with Bluetooth | Model Name. : | FLIP 3 |
| Temperature: | 20 °C | Relative Humidity: | 48% |
| Pressure: | 1010 hPa | Test Voltage : | DC 3.7V |
| Test Mode : | TX | Polarization : | -- |

| Freq. | Reading | Limit | Margin | State |
|-------|----------|----------|--------|-------|
| (MHz) | (dBuV/m) | (dBuV/m) | (dB) | P/F |
| -- | -- | -- | -- | N/A |
| -- | -- | -- | -- | N/A |

NOTE:

The amplitude of spurious emissions which are attenuated by more than 20dB below the permissible value has no need to be reported.

Distance extrapolation factor = $40 \log(\text{specific distance}/\text{test distance})$ (dB);

Limit line = specific limits(dBuv) + distance extrapolation factor.

3.2.7 TEST RESULTS (BETWEEN 30MHZ – 1GHZ)

| | | | |
|---------------|---------------------------------|---------------------|---------|
| EUT : | Portable speaker with Bluetooth | Model Name : | FLIP 3 |
| Temperature : | 20 °C | Relative Humidity : | 48% |
| Pressure: | 1010 hPa | Test Voltage : | DC 3.7V |
| Test Mode : | TX | | |

| Polar (H/V) | Frequency | Meter Reading | Factor | Emission Level | Limits | Margin | Remark |
|-------------|-----------|---------------|--------|----------------|----------|--------|--------|
| | (MHz) | (dBuV) | (dB) | (dBuV/m) | (dBuV/m) | (dB) | |
| V | 40.8446 | 17.76 | 13.26 | 31.02 | 40.00 | -8.98 | QP |
| V | 50.5860 | 20.17 | 10.52 | 30.69 | 40.00 | -9.31 | QP |
| V | 105.2716 | 14.11 | 9.49 | 23.60 | 43.50 | -19.90 | QP |
| V | 140.3420 | 17.88 | 11.37 | 29.25 | 43.50 | -14.25 | QP |
| V | 199.2855 | 16.05 | 10.78 | 26.83 | 43.50 | -16.67 | QP |

Remark:

Absolute Level= ReadingLevel+ Factor, Margin= Absolute Level - Limit

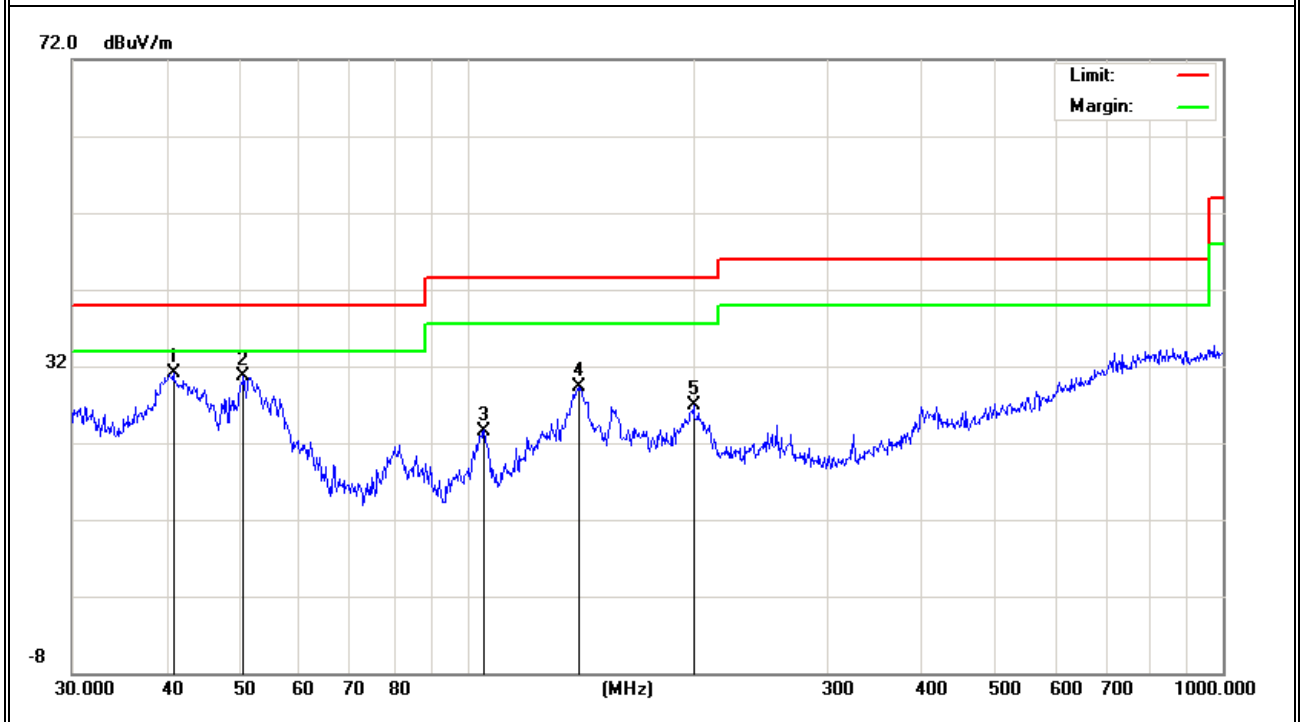

| Polar (H/V) | Frequency | Meter Reading | Factor | Emission Level | Limits | Margin | Remark |
|-------------|-----------|---------------|--------|----------------|----------|--------|--------|
| | (MHz) | (dBuV) | (dB) | (dBuV/m) | (dBuV/m) | (dB) | |
| H | 32.6340 | 6.51 | 17.99 | 24.50 | 40.00 | -15.50 | QP |
| H | 334.8589 | 8.75 | 15.61 | 24.36 | 46.00 | -21.64 | QP |
| H | 417.6411 | 10.08 | 18.66 | 28.74 | 46.00 | -17.26 | QP |
| H | 798.9797 | 6.16 | 27.38 | 33.54 | 46.00 | -12.46 | QP |

Remark:

Absolute Level= ReadingLevel+ Factor, Margin= Absolute Level - Limit

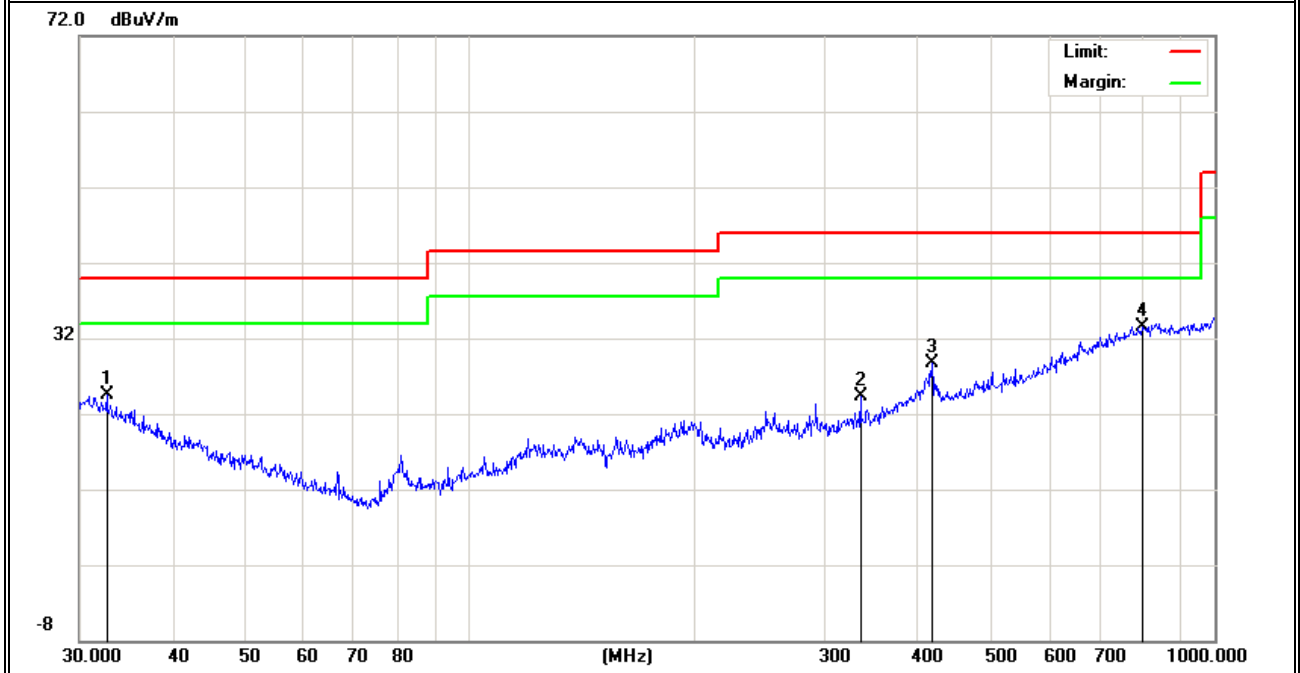

3.2.8 TEST RESULTS (ABOVE 1000 MHZ)

| | | | |
|---------------|---------------------------------|---------------------|---------|
| EUT : | Portable speaker with Bluetooth | Model Name : | FLIP 3 |
| Temperature : | 20 °C | Relative Humidity : | 48% |
| Pressure: | 1010 hPa | Test Voltage : | DC 3.7V |
| Test Mode : | TX | | |

| Frequency (MHz) | Reading (dBµV) | Factor (dB) | Corrected Amplitude (dBµV/m) | Limit (dBµV/m) | Margin (dB) | Remark | Polar (H/V) |
|----------------------------------|----------------|-------------|------------------------------|----------------|-------------|--------|-------------|
| Low Channel (2402 MHz)-Above 1G | | | | | | | |
| 4804.147 | 59.07 | -3.64 | 62.71 | 74.00 | -11.29 | Pk | Vertical |
| 4804.147 | 41.41 | -3.64 | 45.05 | 54.00 | -8.95 | AV | Vertical |
| 7206.206 | 59.22 | -0.95 | 60.17 | 74.00 | -13.83 | Pk | Vertical |
| 7206.206 | 37.35 | -0.95 | 38.30 | 54.00 | -15.70 | AV | Vertical |
| 4804.123 | 59.45 | -3.64 | 63.09 | 74.00 | -10.91 | Pk | Horizontal |
| 4804.123 | 42.31 | -3.64 | 45.95 | 54.00 | -8.05 | AV | Horizontal |
| 7206.058 | 57.42 | -0.95 | 58.37 | 74.00 | -15.63 | Pk | Horizontal |
| 7206.058 | 37.24 | -0.95 | 38.19 | 54.00 | -15.81 | AV | Horizontal |
| Mid Channel (2440 MHz)-Above 1G | | | | | | | |
| 4880.362 | 59.82 | -3.68 | 63.50 | 74.00 | -10.50 | Pk | Vertical |
| 4880.362 | 41.85 | -3.68 | 45.53 | 54.00 | -8.47 | AV | Vertical |
| 7320.261 | 59.21 | -0.82 | 60.03 | 74.00 | -13.97 | Pk | Vertical |
| 7320.261 | 40.05 | -0.82 | 40.87 | 54.00 | -13.13 | AV | Vertical |
| 4880.107 | 61.72 | -3.68 | 65.40 | 74.00 | -8.60 | Pk | Horizontal |
| 4880.107 | 44.85 | -3.68 | 48.53 | 54.00 | -5.47 | AV | Horizontal |
| 7320.165 | 59.15 | -0.82 | 59.97 | 74.00 | -14.03 | Pk | Horizontal |
| 7320.165 | 39.32 | -0.82 | 40.14 | 54.00 | -13.86 | AV | Horizontal |
| High Channel (2480MHz)- Above 1G | | | | | | | |
| 4960.158 | 59.14 | -3.59 | 62.73 | 74.00 | -11.27 | Pk | Vertical |
| 4960.158 | 41.99 | -3.59 | 45.58 | 54.00 | -8.42 | AV | Vertical |
| 7440.325 | 57.61 | -0.68 | 58.29 | 74.00 | -15.71 | Pk | Vertical |
| 7440.325 | 41.87 | -0.68 | 42.55 | 54.00 | -11.45 | AV | Vertical |
| 4960.218 | 58.97 | -3.59 | 62.56 | 74.00 | -11.44 | Pk | Horizontal |
| 4960.218 | 42.15 | -3.59 | 45.74 | 54.00 | -8.26 | AV | Horizontal |
| 7440.314 | 60.53 | -0.68 | 61.21 | 74.00 | -12.79 | Pk | Horizontal |
| 7440.314 | 39.34 | -0.68 | 40.02 | 54.00 | -13.98 | AV | Horizontal |

Remark:

Absolute Level= ReadingLevel+ Factor, Margin= Absolute Level - Limit

4. POWER SPECTRAL DENSITY TEST

4.1 APPLIED PROCEDURES / LIMIT

| FCC Part15 (15.247) , Subpart C | | | | |
|---------------------------------|------------------------|------------------------|-----------------------|--------|
| Section | Test Item | Limit | Frequency Range (MHz) | Result |
| 15.247 | Power Spectral Density | 8 dBm (in any 3KHz) | 2400-2483.5 | PASS |

4.1.1 TEST PROCEDURE

1. Set analyzer center frequency to DTS channel center frequency.
2. Set the span to 1.5 times the DTS channel bandwidth.
3. 3 kHz \leq Set the RBW \leq 100 kHz.
4. Set the VBW \geq 3 x RBW.
5. Detector = peak.
6. Sweep time = auto couple.
7. Trace mode = max hold.
8. Allow trace to fully stabilize.
9. Use the peak marker function to determine the maximum amplitude level within the RBW.
10. If measured value exceeds limit, reduce RBW (no less than 3 kHz) and repeat.

4.1.2 DEVIATION FROM STANDARD

No deviation.

4.1.3 TEST SETUP

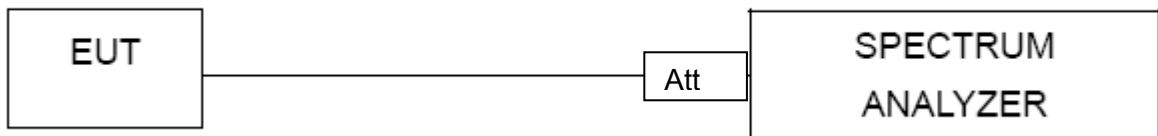

4.1.4 EUT OPERATION CONDITIONS

The EUT tested system was configured as the statements of 2.1 Unless otherwise a special operating condition is specified in the follows during the testing.

4.1.5 TEST RESULTS

| | | | |
|---------------|---------------------------------|---------------------|---------|
| EUT : | Portable speaker with Bluetooth | Model Name : | FLIP 3 |
| Temperature : | 25 °C | Relative Humidity : | 56% |
| Pressure : | 1015 hPa | Test Voltage : | DC 3.7V |
| Test Mode : | TX Mode /CH00, CH19, CH39 | | |

| Frequency | Power Density (dBm) | Limit (dBm) | Result |
|-----------|---------------------|-------------|--------|
| 2402 MHz | -13.39 | 8 | PASS |
| 2440 MHz | -13.36 | 8 | PASS |
| 2480 MHz | -12.75 | 8 | PASS |

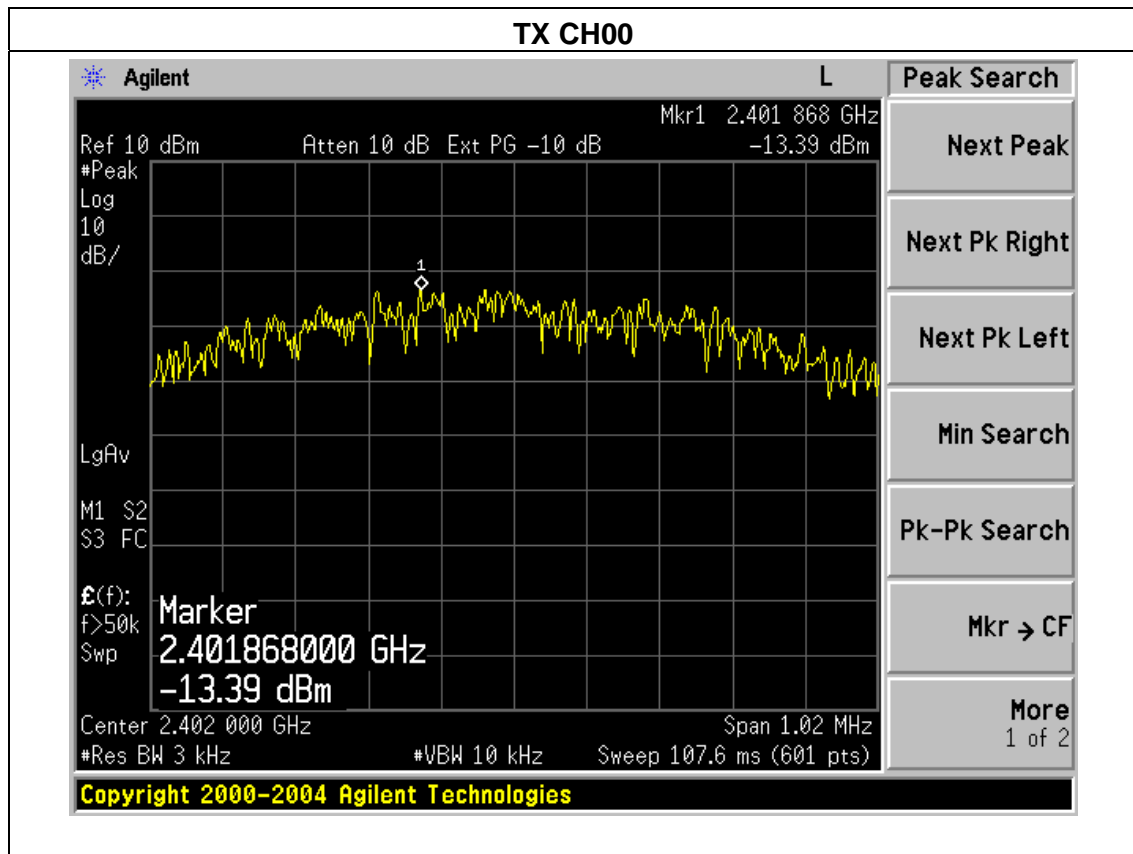

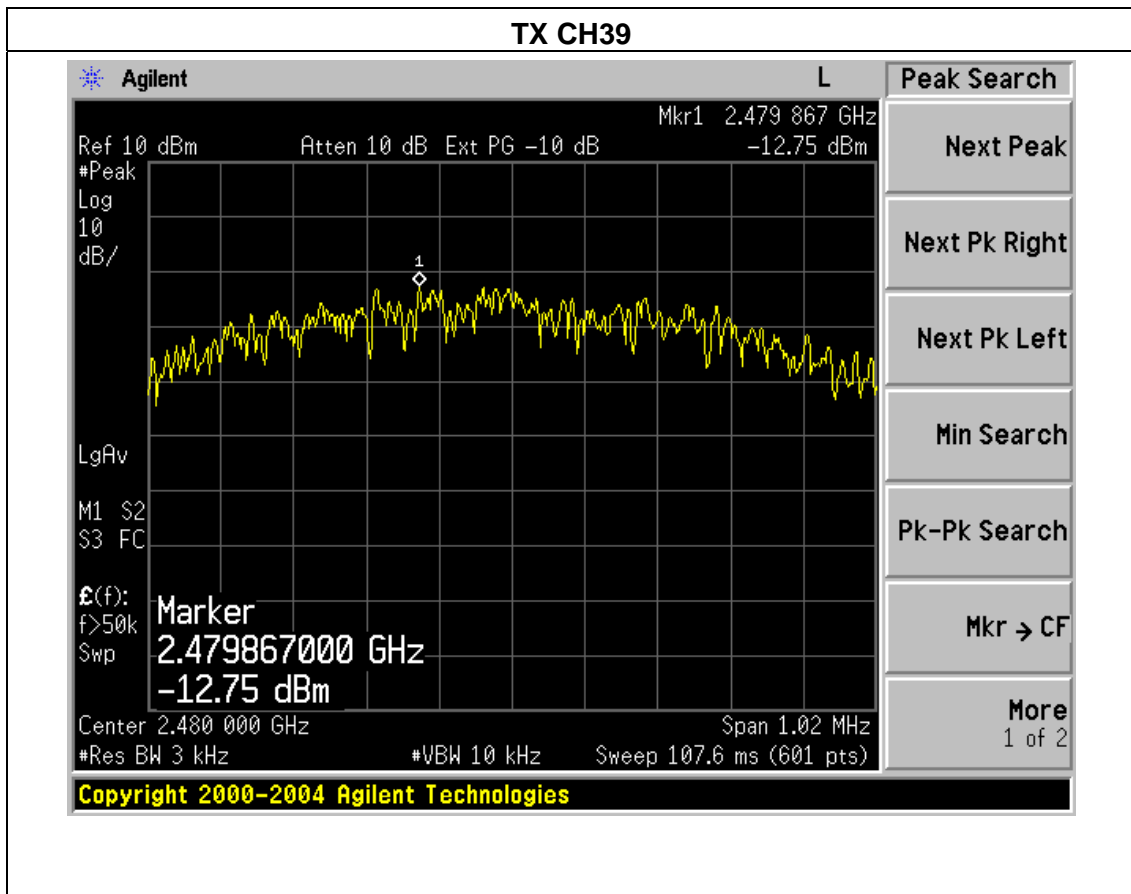
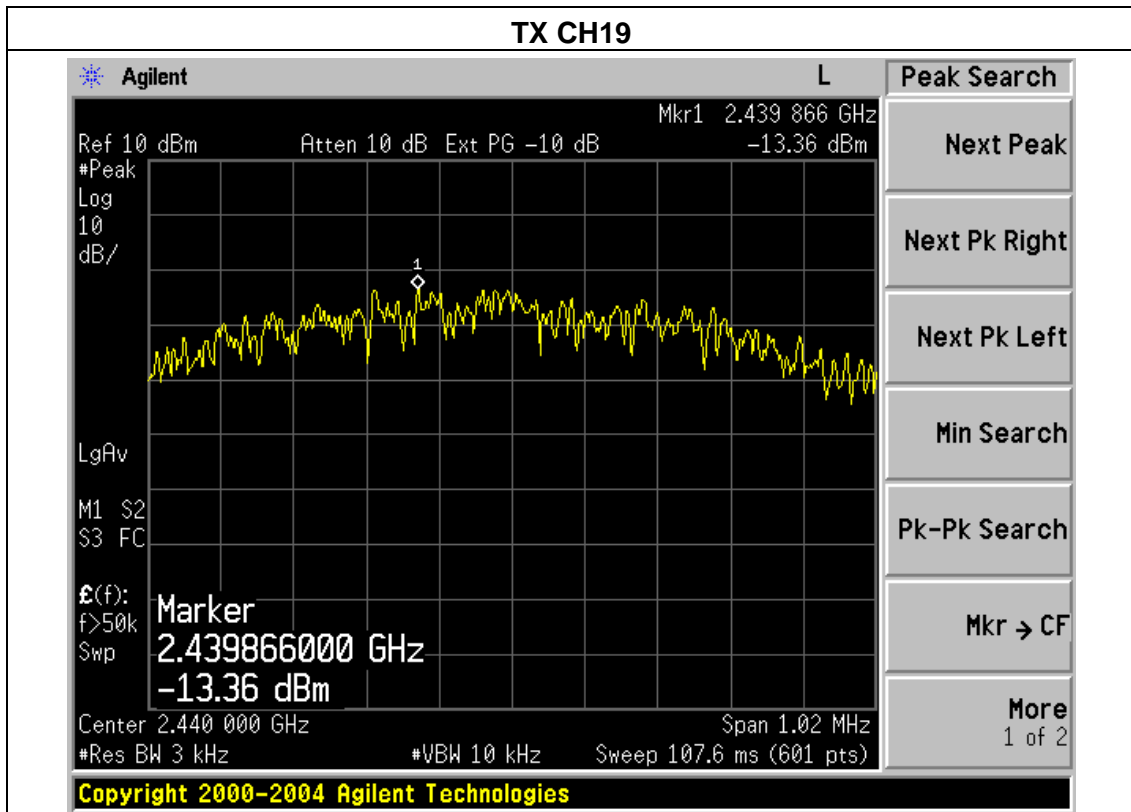

5. BANDWIDTH TEST

5.1 APPLIED PROCEDURES / LIMIT

| FCC Part15 (15.247) , Subpart C | | | | |
|---------------------------------|-----------|---|-----------------------|--------|
| Section | Test Item | Limit | Frequency Range (MHz) | Result |
| 15.247(a)(2) | Bandwidth | $\geq 500\text{KHz}$ (6dB bandwidth) | 2400-2483.5 | PASS |

5.1.1 TEST PROCEDURE

1. Set RBW = 100 kHz.
2. Set the video bandwidth (VBW) $\geq 3 \times$ RBW.
3. Detector = Peak.
4. Trace mode = max hold.
5. Sweep = auto couple.
6. Allow the trace to stabilize.
7. Measure the maximum width of the emission that is constrained by the frequencies associated with the two outermost amplitude points (upper and lower) that are attenuated by 6 dB relative to the maximum level measured in the fundamental emission.

TEST SETUP

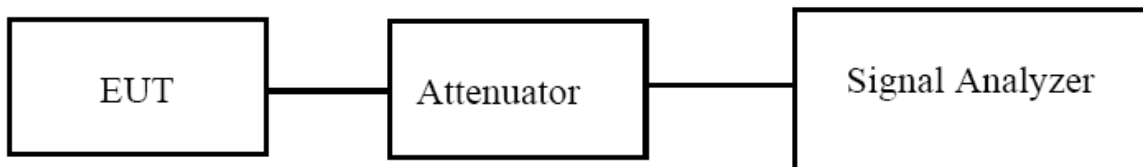

5.1.2 EUT OPERATION CONDITIONS

The EUT tested system was configured as the statements of 2.4 Unless otherwise a special operating condition is specified in the follows during the testing.

5.1.3 TEST RESULTS

| | | | |
|---------------|---------------------------------|---------------------|---------|
| EUT : | Portable speaker with Bluetooth | Model Name : | FLIP 3 |
| Temperature : | 25 °C | Relative Humidity : | 56% |
| Pressure : | 1012 hPa | Test Voltage : | DC 3.7V |
| Test Mode : | TX Mode /CH00, CH19, CH39 | | |

| Channel | Frequency (MHz) | 99% Bandwidth (MHz) | 6dB bandwidth (kHz) | Limit (kHz) | Result |
|---------|-----------------|---------------------|---------------------|-------------|--------|
| Low | 2402 | 1.0514 | 701.069 | 500 | Pass |
| Middle | 2440 | 1.0443 | 694.079 | 500 | Pass |
| High | 2480 | 1.0450 | 684.841 | 500 | Pass |

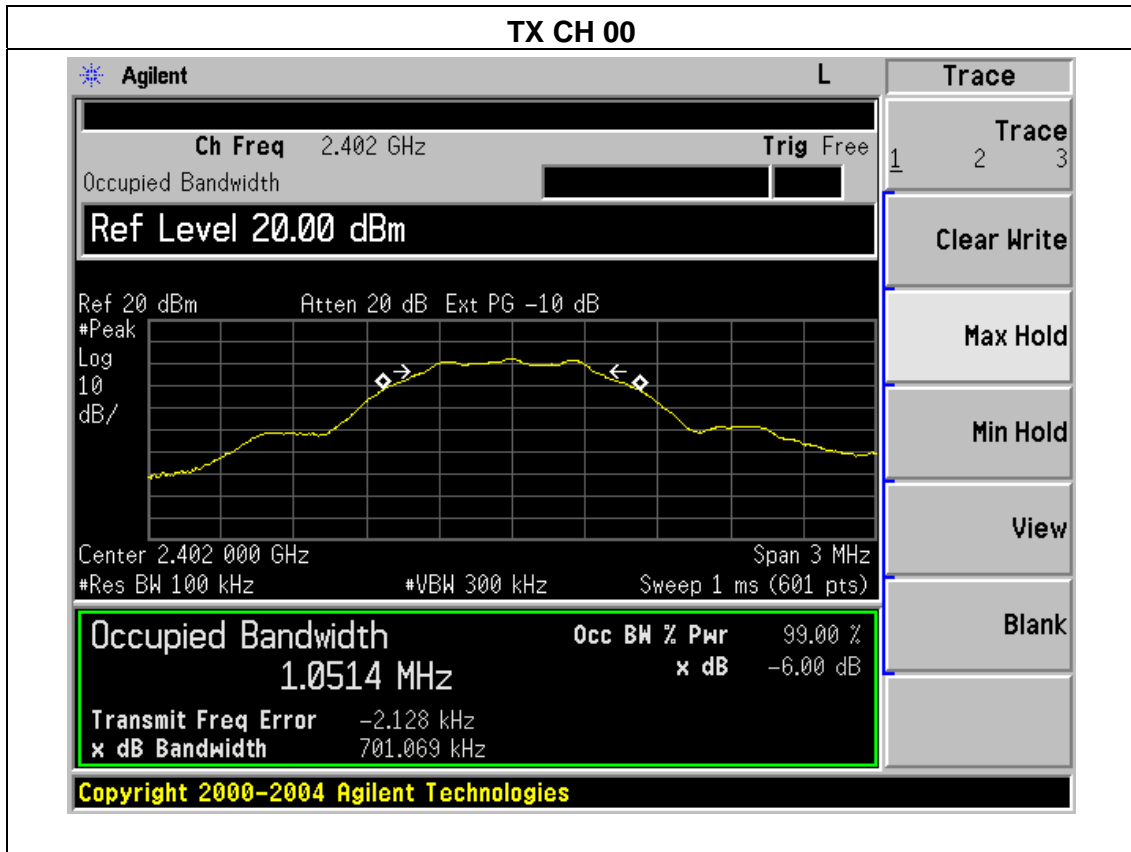

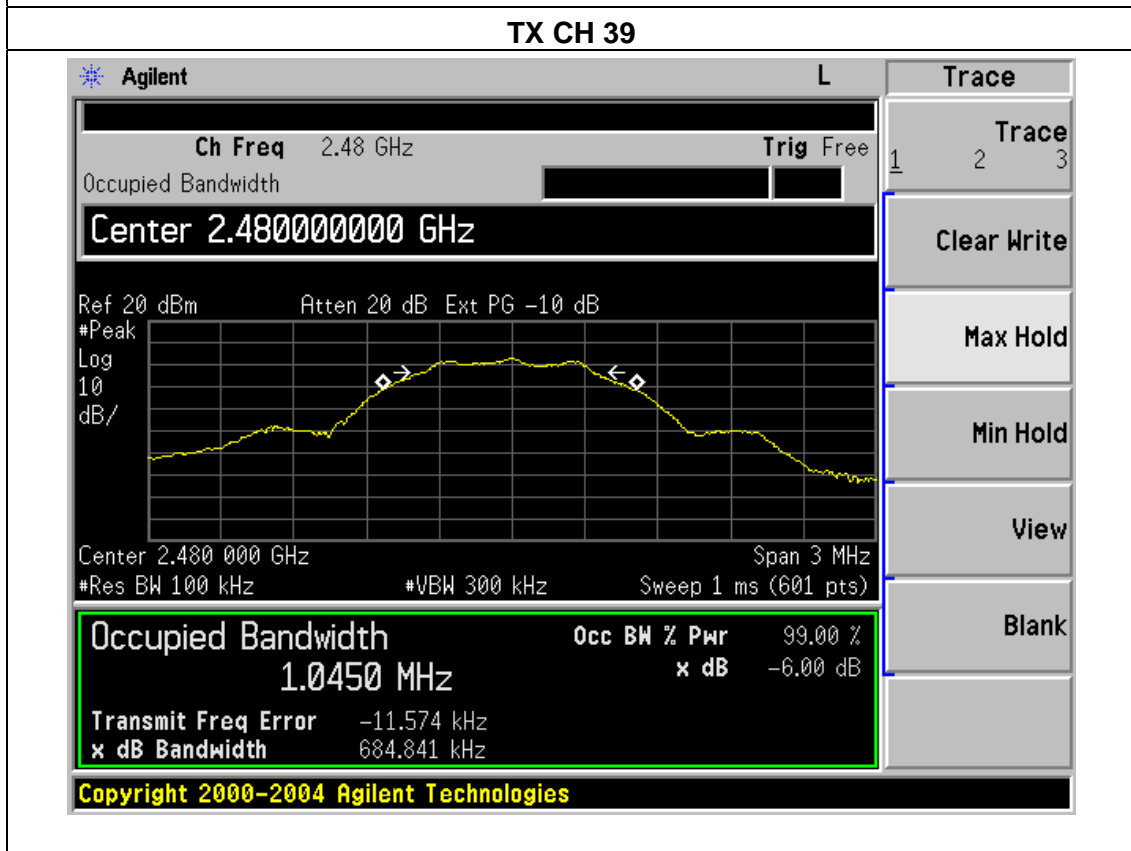
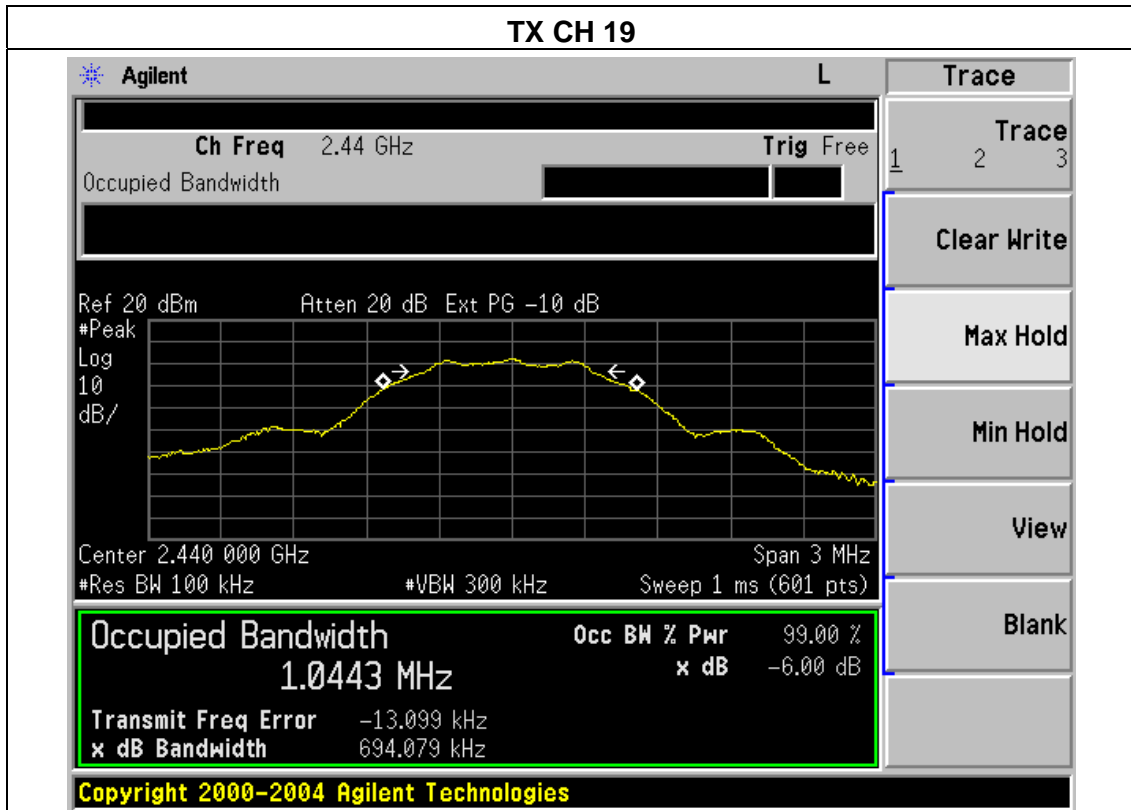

6. PEAK OUTPUT POWER TEST

6.1 APPLIED PROCEDURES / LIMIT

| FCC Part15 (15.247) , Subpart C | | | | |
|---------------------------------|-------------------|-----------------|-----------------------|--------|
| Section | Test Item | Limit | Frequency Range (MHz) | Result |
| 15.247(b)(3) | Peak Output Power | 1 watt or 30dBm | 2400-2483.5 | PASS |

6.1.1 TEST PROCEDURE

- a. The EUT was directly connected to the Power meter

6.1.2 DEVIATION FROM STANDARD

No deviation.

6.1.3 TEST SETUP



6.1.4 EUT OPERATION CONDITIONS

The EUT tested system was configured as the statements of 2.4 Unless otherwise a special operating condition is specified in the follows during the testing.

6.1.5 TEST RESULTS

| | | | |
|---------------|---------------------------------|---------------------|---------|
| EUT : | Portable speaker with Bluetooth | Model Name : | FLIP 3 |
| Temperature : | 25 °C | Relative Humidity : | 60% |
| Pressure : | 1012 hPa | Test Voltage : | DC 3.7V |
| Test Mode : | TX Mode | | |

| Test Channe | Frequency | Maximum Conducted Output Power(PK) | LIMIT |
|-------------|-----------|------------------------------------|-------|
| | (MHz) | (dBm) | dBm |
| CH00 | 2402 | 2.43 | 30 |
| CH19 | 2440 | 2.38 | 30 |
| CH39 | 2480 | 2.90 | 30 |

7. 100 KHZ BANDWIDTH OF FREQUENCY BAND EDGE

APPLICABLE STANDARD

In any 100 kHz bandwidth outside the frequency band in which the spread spectrum or digitally modulated intentional radiator is operating, the radio frequency power that is produced by the intentional radiator shall be at least 20 dB below that in the 100 kHz bandwidth within the band that contains the highest level of the desired power, based on either an RF conducted or a radiated measurement, provided the transmitter demonstrates compliance with the peak conducted power limits. If the transmitter complies with the conducted power limits based on the use of RMS averaging over a time interval, as permitted under paragraph (b)(3) of this section, the attenuation required under this paragraph shall be 30 dB instead of 20 dB. Attenuation below the general limits specified in §15.209(a) is not required. In addition, radiated emissions which fall in the restricted bands, as defined in §15.205(a), must also comply with the radiated emission limits specified in §15.209(a) (see §15.205(c)).

TEST PROCEDURE

- a) Check the calibration of the measuring instrument using either an internal calibrator or a known signal from an external generator.
- b) Position the EUT without connection to measurement instrument. Turn on the EUT and connect its antenna terminal to measurement instrument via a low loss cable. Then set it to any one measured frequency within its operating range, and make sure the instrument is operated in its linear range.
- c) Set RBW to 100 kHz and VBW of spectrum analyzer to 300 kHz with a convenient frequency span including 100 kHz bandwidth from band edge.
- d) Measure the highest amplitude appearing on spectral display and set it as a reference level. Plot the graph with marking the highest point and edge frequency.
- e) Repeat above procedures until all measured frequencies were complete.

7.1 DEVIATION FROM STANDARD

No deviation.

7.2 TEST SETUP

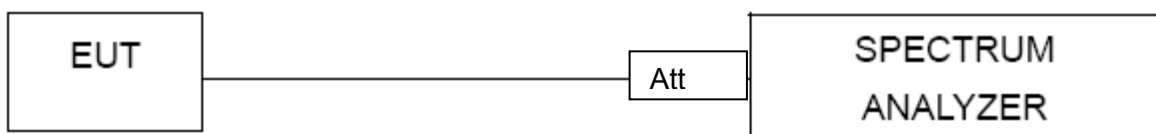

7.3 EUT OPERATION CONDITIONS

The EUT tested system was configured as the statements of 2.4 Unless otherwise a special operating condition is specified in the follows during the testing.

7.4 TEST RESULTS

| | | | |
|---------------|---------------------------------|---------------------|---------|
| EUT : | Portable speaker with Bluetooth | Model Name : | FLIP 3 |
| Temperature : | 25 °C | Relative Humidity : | 56% |
| Pressure : | 1012 hPa | Test Voltage : | DC 3.7V |

| Frequency Band | Delta Peak to band emission (dBc) | > Limit (dBc) | Result |
|----------------|-----------------------------------|---------------|--------|
| Left-band | 51.28 | 20 | Pass |
| Right-band | 63.21 | 20 | Pass |

Radiated band edge:

| Frequency (MHz) | Meter Reading (dBµV) | Factor (dB) | Emission Level (dBµV/m) | Limits (dBµV/m) | Margin (dB) | Detector Type | Comment |
|-----------------|----------------------|-------------|-------------------------|-----------------|-------------|---------------|------------|
| 2390 | 56.66 | -13.06 | 43.6 | 74 | -30.40 | peak | Vertical |
| 2390 | 56.46 | -13.06 | 43.4 | 74 | -30.60 | peak | Horizontal |
| 2483.5 | 57.59 | -12.78 | 44.81 | 74 | -29.19 | peak | Vertical |
| 2483.5 | 57.64 | -12.78 | 44.86 | 74 | -29.14 | peak | Horizontal |

Note: Test method to see chapter 3.2 . When PK value is lower than the Average value limit, average not record.

Left Side

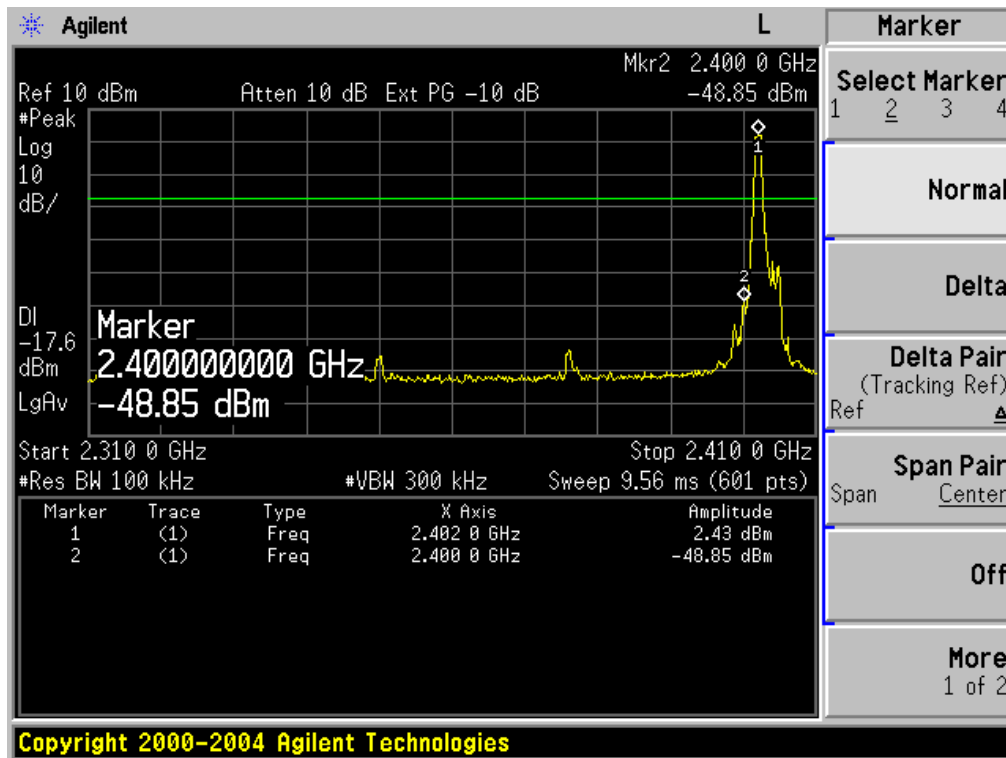

Right Side

