

FCC 47 CFR PART 15 SUBPART C

Applicant : Harman International Industries, Incorporated
Product Type : Portable Bluetooth speaker
Trade Name : JBL
Model Number : CLIP2 AN
Test Specification : FCC 47 CFR PART 15 SUBPART C
ANSI C63.10:2013
Receive Date : Feb. 01, 2016
Test Period : Feb. 04 ~ Mar. 15, 2016
Issue Date : Mar. 23, 2016

Issue by

A Test Lab Techno Corp.
No. 140-1, Changan Street, Bade District,
Taoyuan City 33465, Taiwan (R.O.C)
Tel : +886-3-2710188 / Fax : +886-3-2710190



Taiwan Accreditation Foundation accreditation number: 1330

Note: This report shall not be reproduced except in full, without the written approval of A Test Lab Techno Corp. This document may be altered or revised by A Test Lab Techno Corp. personnel only, and shall be noted in the revision section of the document. The client should not use it to claim product endorsement by TAF, or any government agencies. The test results in the report only apply to the tested sample.

Revision History

Rev.	Issue Date	Revisions	Revised By
00	Mar. 09, 2016	Initial Issue	
01	Mar. 23, 2016	Revised report information.	Peggy Chang

Verification of Compliance

Issued Date: Mar. 23, 2016

Applicant : Harman International Industries, Incorporated
Product Type : Portable Bluetooth speaker
Trade Name : JBL
Model Number : CLIP2 AN
FCC ID : APIJBLCLIP2AN
EUT Rated Voltage : DC 5V, 0.5A
Test Voltage : 120 Vac / 60 Hz
Applicable Standard : FCC 47 CFR PART 15 SUBPART C
ANSI C63.10:2013

Test Result : Complied

Performing Lab. : A Test Lab Techno Corp.

No. 140-1, Changan Street, Bade District,
Taoyuan City 33465, Taiwan (R.O.C)
Tel : +886-3-2710188 / Fax : +886-3-2710190



Taiwan Accreditation Foundation accreditation number: 1330
<http://www.atl-lab.com.tw/e-index.htm>

A Test Lab Techno Corp. tested the above equipment in accordance with the requirements set forth in the above standards. All indications of Pass/Fail in this report are opinions expressed by A Test Lab Techno Corp. based on interpretations and/or observations of test results. Measurement Uncertainties were not taken into account and are published for informational purposes only. The test results show that the equipment tested is capable of demonstrating compliance with the requirements as documented in this report.

Approved By



(Manager)

(Fly Lu)

Reviewed By

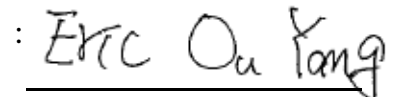

(Testing Engineer)

(Eric Ou Yang)

TABLE OF CONTENTS

1	General Information	6
2	EUT Description.....	7
3	Test Methodology.....	8
	3.1. Mode of Operation.....	8
	3.2. EUT Exercise Software	8
	3.3. Configuration of Test System Details.....	9
	3.4. Test Site Environment.....	10
4	Conducted Emission Measurement.....	11
	4.1. Limit.....	11
	4.2. Test Instruments	11
	4.3. Test Setup	11
	4.4. Test Procedure	12
	4.5. Test Result.....	13
5	Radiated Emission Measurement	15
	5.1. Limit.....	15
	5.2. Test Instruments	15
	5.3. Setup.....	16
	5.4. Test Procedure	18
	5.5. Test Result.....	20
6	Maximum Conducted Output Power Measurement.....	24
	6.1. Limit.....	24
	6.2. Test Setup	24
	6.3. Test Instruments	24
	6.4. Test Procedure	24
	6.5. Test Result.....	25
7	6dB RF Bandwidth and 99 % Occupied Bandwidth Measurement.....	26
	7.1. Limit.....	26
	7.2. Test Setup	26
	7.3. Test Instruments	26
	7.4. Test Procedure	27
	7.5. Test Result.....	27
	7.6. Test Graphs	28

8	Maximum Power Density Measurement	29
8.1.	Limit.....	29
8.2.	Test Setup	29
8.3.	Test Instruments	29
8.4.	Test Procedure	29
8.5.	Test Result.....	30
8.6.	Test Graphs	31
9	Out of Band Conducted Emissions Measurement	32
9.1.	Limit.....	32
9.2.	Test Setup	32
9.3.	Test Instruments	32
9.4.	Test Procedure	32
9.5.	Test Graphs	33
10	Antenna Measurement	36
10.1.	Limit.....	36
10.2.	Antenna Connector Construction	36

1 General Information

1.1 Summary of Test Result

Standard	Item	Result	Remark
15.207	AC Power Conducted Emission	PASS	-----
15.247(d)	Transmitter Radiated Emissions	PASS	-----
15.247(b)(3)	Max. Output Power	PASS	-----
15.247(a)(2)	6dB RF Bandwidth	PASS	-----
15.247(e)	Power Spectral Density	PASS	-----
15.247(d)	Out of Band Conducted Spurious Emission	PASS	-----
15.203	Antenna Requirement	PASS	-----

The test results of this report relate only to the tested sample(s) identified in this report. Manufacturer or whom it may concern should recognize the pass or fail of the test result.

1.2 Measurement Uncertainty

Test Item	Frequency Range	Uncertainty (dB)
Conducted Emission	9kHz ~ 150KHz	2.7
	150kHz ~ 30MHz	2.8
Radiated Emission	9kHz ~ 30MHz	1.457
	30MHz ~ 1000MHz	6.300
	1000MHz ~ 18000MHz	5.474
	18000MHz ~ 26500MHz	5.630
	26500MHz ~ 40000MHz	5.054

2 EUT Description

Applicant	Harman International Industries, Incorporated 8500 Balboa Blvd, Northridge, CA 91329, UNITED STATES
Manufacturer	Harman International Industries, Incorporated 8500 Balboa Blvd, Northridge, CA 91329, UNITED STATES
Product Type	Portable Bluetooth speaker
Trade Name	JBL
Model No.	CLIP2 AN
FCC ID	APIJBLCLIP2AN
Frequency Range	Bluetooth LE: 2402 ~ 2480 MHz
Modulation Type	GFSK
Antenna Type	PCB Antenna
Antenna Gain	0 dBi
RF Output Power	0.00237 W / 3.75 dBm

3 Test Methodology

3.1. Mode of Operation

Decision of Test ATL has verified the construction and function in typical operation. All the test modes were carried out with the EUT in normal operation, which was shown in this test report and defined as:

Test Mode
Mode 1: TX Mode
Mode 2: Bluetooth LE TX Mode

Software used to control the EUT for staying in continuous transmitting mode was programmed.

After verification, all tests were carried out with the worst case test modes as shown below except radiated spurious emission below 1GHz and power line conducted emissions below 30MHz, which worst case was in normal link mode only.

By preliminary testing and verifying three axis (X, Y and Z) position of EUT transmitted status, it was found that "X axis" position was the worst, then the final test was executed the worst condition and test data were recorded in this report.

Note: The EUT was programmed to be in continuously transmitting mode and the transmit duty cycle is not less than 98%.

3.2. EUT Exercise Software

1	Setup the EUT shown on 3.3.
2	Turn on the power of all equipment.
3	Turn Bluetooth function link to CBT.
4	EUT run test program.

Measurement Software	
1	EZ-EMC Ver. ATL-03A1-1
2	EZ-EMC Ver ATL-ITC-3A1-1

3.3. Configuration of Test System Details

Conducted Emissions

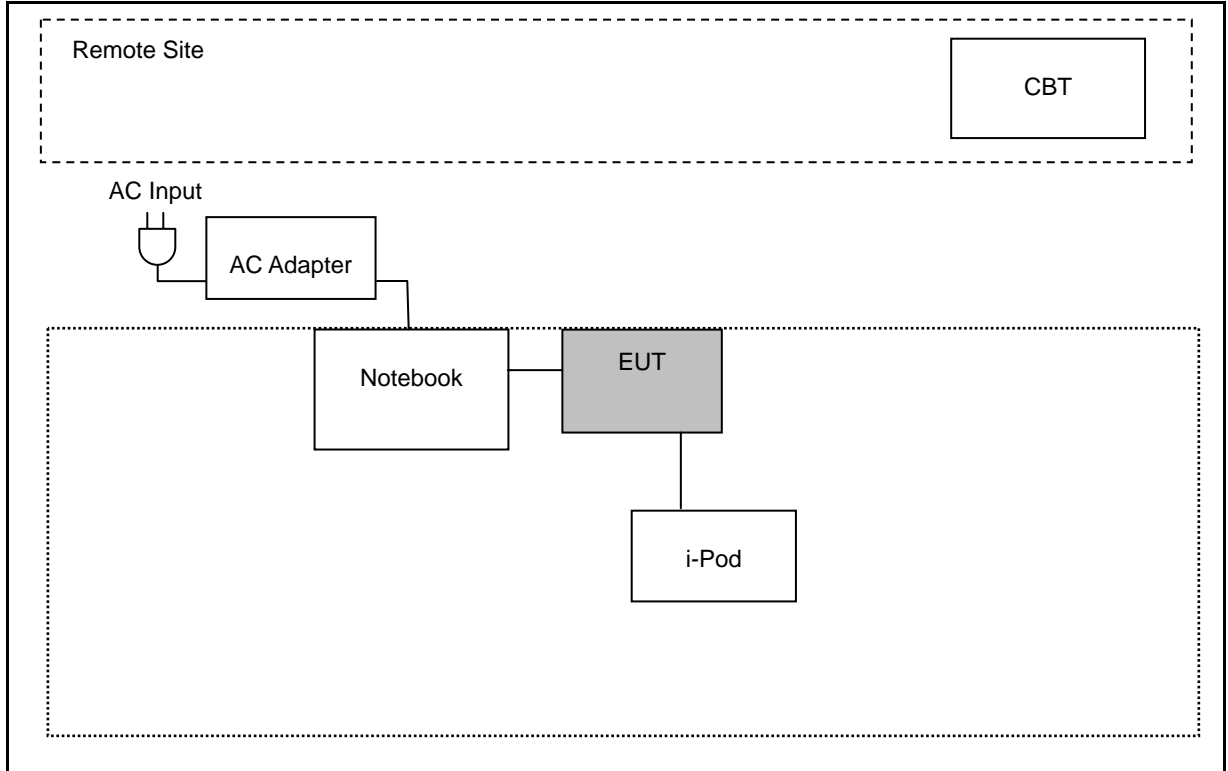

Radiated Emissions

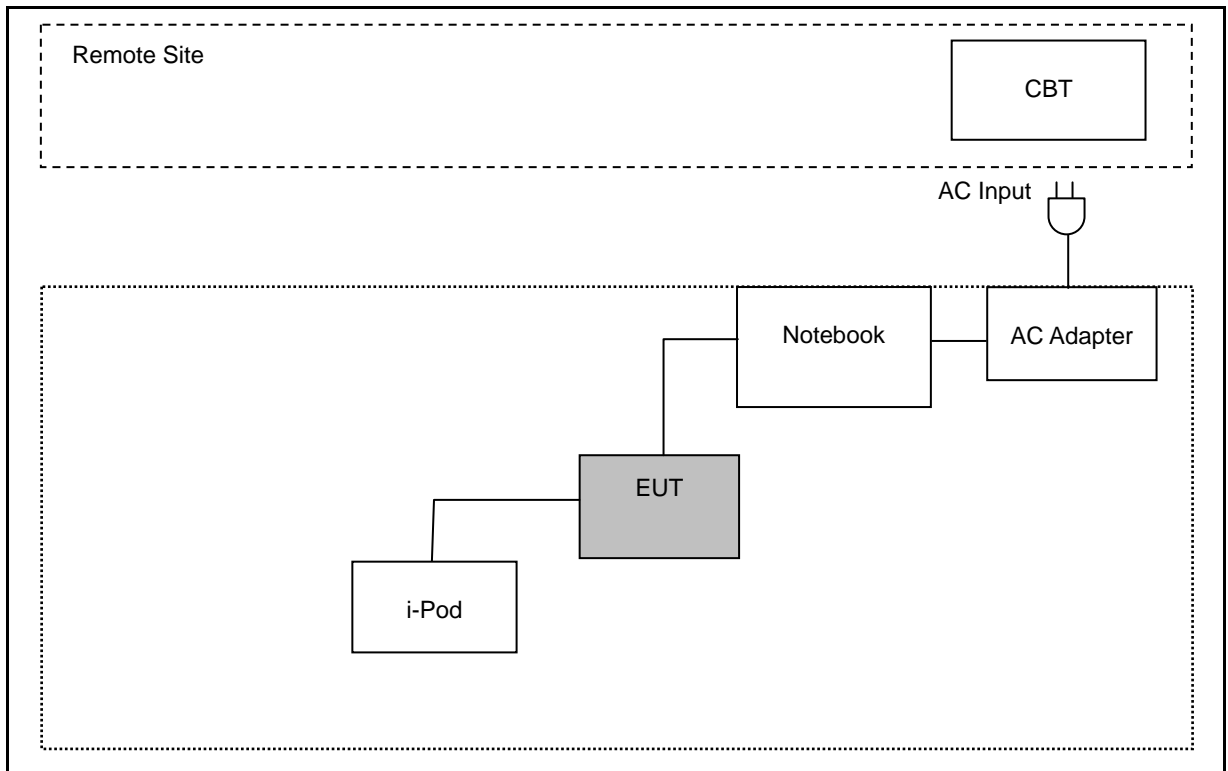

3.4. Test Site Environment

Items	Required (IEC 60068-1)	Actual
Temperature (°C)	15-35	26
Humidity (%RH)	25-75	60
Barometric pressure (mbar)	860-1060	950

4 Conducted Emission Measurement

4.1. Limit

Frequency (MHz)	Quasi-peak	Average
0.15 - 0.5	66 to 56	56 to 46
0.50 - 5.0	56	46
5.0 - 30.0	60	50

4.2. Test Instruments

Describe	Manufacturer	Model Number	Serial Number	Cal. Date	Remark
Test Receiver	R&S	ESCI	100367	06/25/2015	(1)
LISN	R&S	ENV216	101040	03/11/2016	(1)
LISN	R&S	ENV216	101041	03/07/2016	(1)
RF Cable	Woken	00100D1380194M	TE-02-02	06/26/2015	(1)
Test Site	ATL	TE02	TE02	N.C.R.	-----

Remark: (1) Calibration period 1 year. (2) Calibration period 2 years. (3) Calibration period 3 years.

Note: N.C.R. = No Calibration Request.

4.3. Test Setup

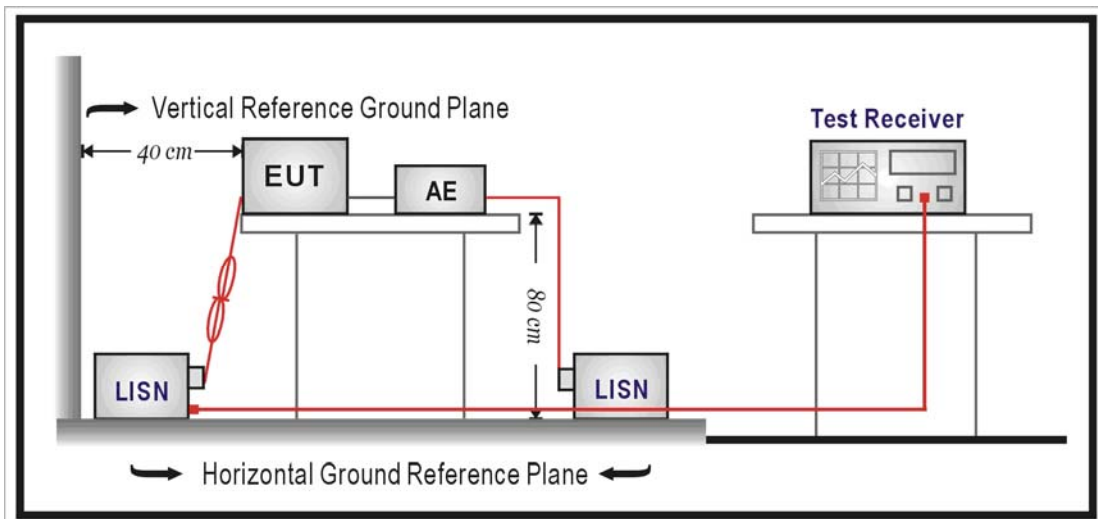

4.4. Test Procedure

The EUT and simulators are connected to the main power through a line impedance stabilization network (L.I.S.N.). This provides a 50 ohm /50uH coupling impedance for the measuring equipment. The peripheral devices are also connected to the main power through a LISN that provides a 50ohm/50uH coupling impedance with 50ohm termination.

For A.C. mains conducted interference, measured both sides of A.C. lines and carried out using quasi-peak and average detector receivers of maximum conducted interference.

Conducted emissions were investigated over the frequency range from 0.15 MHz to 30 MHz using a receiver bandwidth of 9 kHz. The equipment under test (EUT) shall meet the limits in section 4.1, as applicable, including the average limit and the quasi-peak limit when using respectively, an average detector and quasi-peak detector measured in accordance with the methods described of related standard. The voltage limits shall be met. If the average limit is met when using a quasi-peak detector receiver, the EUT shall be deemed to meet both limits and measurement with the average detector receiver is unnecessary.

If the reading of the measuring receiver shows fluctuations close to the limit, the reading shall be observed for at least 15 s at each measurement frequency; the higher reading shall be recorded with the exception of any brief isolated high reading which shall be ignored.

4.5. Test Result

Standard:	FCC Part 15C	Line:	L1
Test item:	Conducted Emission	Power:	AC 120V/60Hz
Model Number:	CLIP2 AN	Temp.(°C)/Hum.(%RH):	26(°C)/60%RH
Mode:	1	Date:	03/15/2016
		Test By:	Eric Ou Yang
Description:			

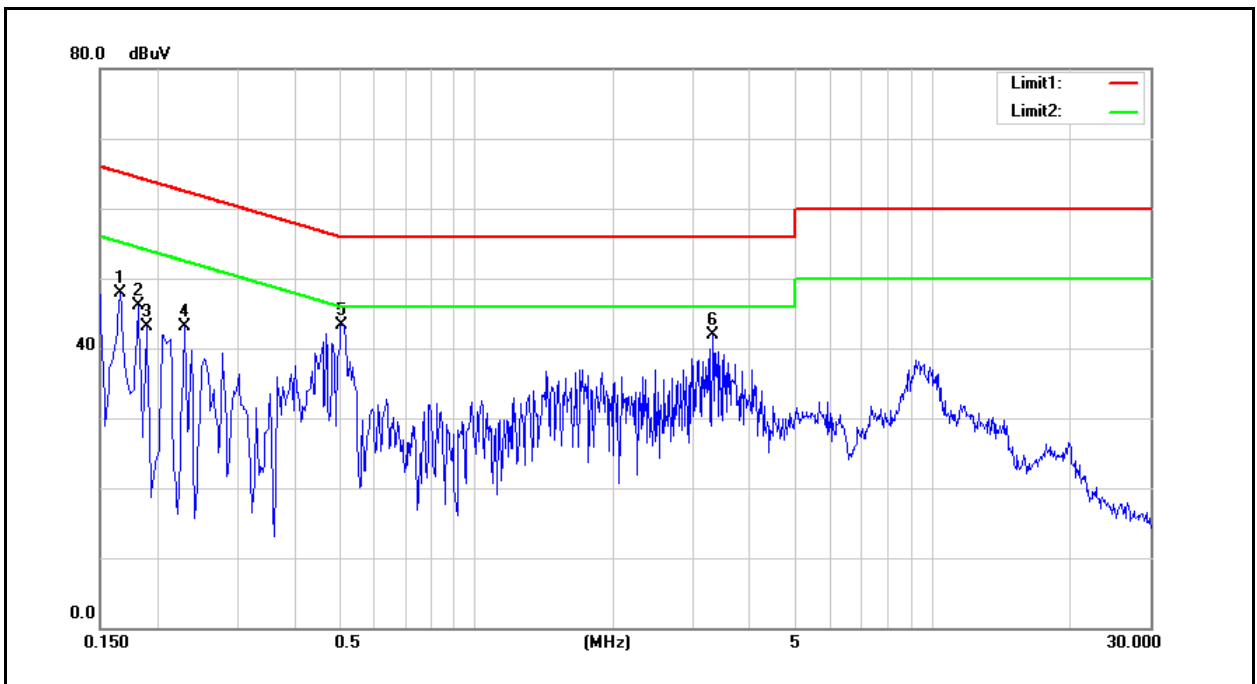

No.	Frequency (MHz)	QP reading (dBuV)	AVG reading (dBuV)	Correction factor (dB)	QP result (dBuV)	AVG result (dBuV)	QP limit (dBuV)	AVG limit (dBuV)	QP margin (dB)	AVG margin (dB)	Remark
1	0.1660	36.97	23.98	9.60	46.57	33.58	65.16	55.16	-18.59	-21.58	Pass
2	0.1820	29.07	8.47	9.59	38.66	18.06	64.39	54.39	-25.73	-36.33	Pass
3	0.1900	29.92	10.99	9.59	39.51	20.58	64.04	54.04	-24.53	-33.46	Pass
4	0.2300	23.67	4.45	9.59	33.26	14.04	62.45	52.45	-29.19	-38.41	Pass
5	0.5100	30.49	17.98	9.61	40.10	27.59	56.00	46.00	-15.90	-18.41	Pass
6	3.3100	25.21	15.65	9.74	34.95	25.39	56.00	46.00	-21.05	-20.61	Pass

Note: 1. Result (dBuV) = Correction factor (dB) + Reading(dBuV).

2. Correction factor (dB) = Cable loss (dB) + L.I.S.N. factor (dB).

Standard:	FCC Part 15C	Line:	N
Test item:	Conducted Emission	Power:	AC 120V/60Hz
Model Number:	CLIP2 AN	Temp.(°C)/Hum.(%RH):	26(°C)/60%RH
Mode:	1	Date:	03/15/2016
		Test By:	Eric Ou Yang
Description:			

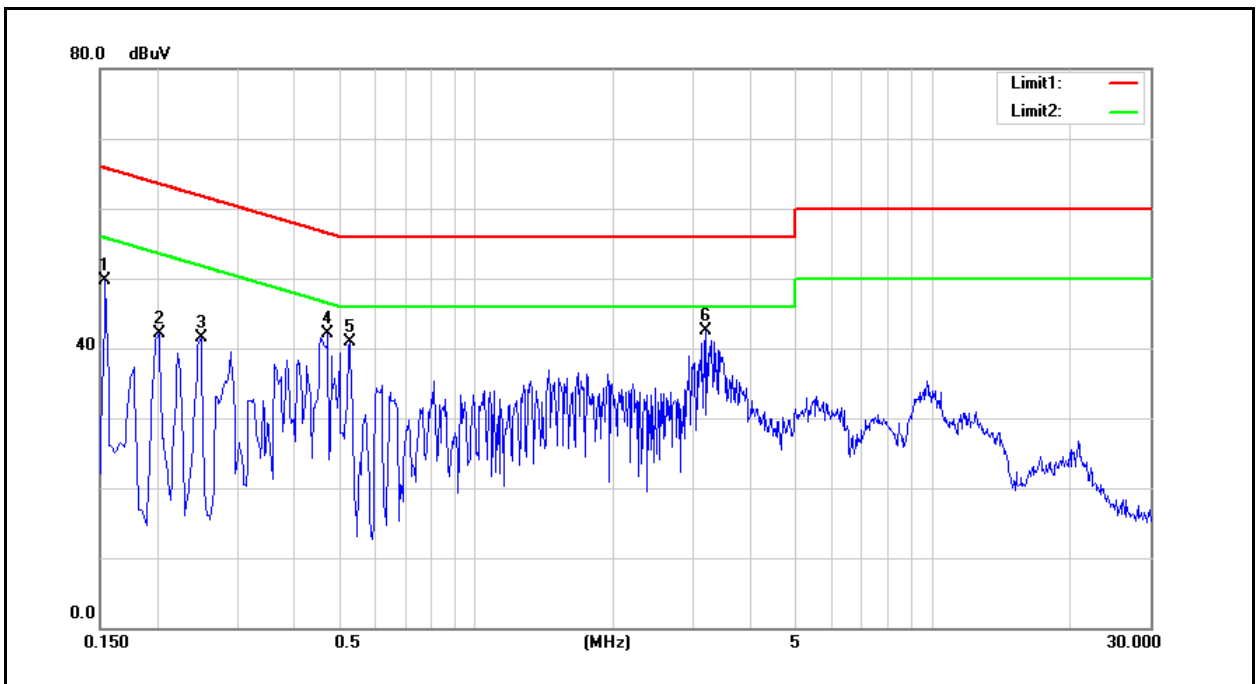

No.	Frequency (MHz)	QP reading (dBuV)	AVG reading (dBuV)	Correction factor (dB)	QP result (dBuV)	AVG result (dBuV)	QP limit (dBuV)	AVG limit (dBuV)	QP margin (dB)	AVG margin (dB)	Remark
1	0.1540	35.63	26.02	9.59	45.22	35.61	65.78	55.78	-20.56	-20.17	Pass
2	0.2020	32.58	22.41	9.58	42.16	31.99	63.53	53.53	-21.37	-21.54	Pass
3	0.2500	29.41	16.63	9.59	39.00	26.22	61.76	51.76	-22.76	-25.54	Pass
4	0.4740	27.53	14.93	9.60	37.13	24.53	56.44	46.44	-19.31	-21.91	Pass
5	0.5300	28.50	20.41	9.60	38.10	30.01	56.00	46.00	-17.90	-15.99	Pass
6	3.2060	26.08	15.57	9.72	35.80	25.29	56.00	46.00	-20.20	-20.71	Pass

Note: 1. Result (dBuV) = Correction factor (dB) + Reading(dBuV).

2. Correction factor (dB) = Cable loss (dB) + L.I.S.N. factor (dB).

5 Radiated Emission Measurement

5.1. Limit

According to §15.209(a), except as provided elsewhere in this subpart, the emissions from an intentional radiator shall not exceed the field strength levels specified in the following table:

Frequency (MHz)	Field Strength ($\mu\text{V}/\text{m}$ at meter)	Measurement Distance (meters)
0.009 – 0.490	2400 / F (kHz)	300
0.490 – 1.705	24000 / F (kHz)	30
1.705 – 30.0	30	30
30 - 88	100**	3
88-216	150**	3
216-960	200**	3
Above 960	500	3

** Except as provided in paragraph (g), fundamental emissions from intentional radiators operating under this Section shall not be located in the frequency bands 54-72 MHz, 76-88 MHz, 174-216 MHz or 470-806 MHz. However, operation within these frequency bands is permitted under other sections of this Part, e.g., Sections 15.231 and 15.241.

5.2. Test Instruments

3 Meter Chamber (966A)					
Equipment	Manufacturer	Model Number	Serial Number	Cal. Date	Remark
RF Pre-selector	Agilent	N9039A	MY46520256	01/08/2016	(1)
Spectrum Analyzer	Agilent	E4446A	MY46180578	01/08/2016	(1)
Pre Amplifier	Agilent	8449B	3008A02237	02/24/2015	(1)
Pre Amplifier	Agilent	8447D	2944A10961	02/24/2015	(1)
Broadband Antenna (30MHz~1GHz)	SCHWARZBECK MESS-ELEKTRONIK	VULB9163	9163-270	08/11/2015	(1)
Horn Antenna (1~18GHz)	SCHWARZBECK MESS-ELEKTRONIK	BBHA9120D	9120D-550	06/12/2015	(1)
Horn Antenna (18~40GHz)	SCHWARZBECK MESS-ELEKTRONIK	BBHA9170	9170-320	07/06/2015	(1)
Loop Antenna	COM-POWER CORPORATION	AL-130	121014	02/01/2016	(1)
Microwave Cable	EMCI	EMC-104-SM-SM-14000	140202	02/24/2015	(1)
Microwave Cable	EMCI	EMC104-SM-SM-600	140301	02/24/2015	(1)
Test Site	ATL	TE01	888001	08/27/2015	(1)

Remark: (1) Calibration period 1 year. (2) Calibration period 2 years

Note: N.C.R. = No Calibration Request.

5.3. Setup

9kHz ~ 30MHz

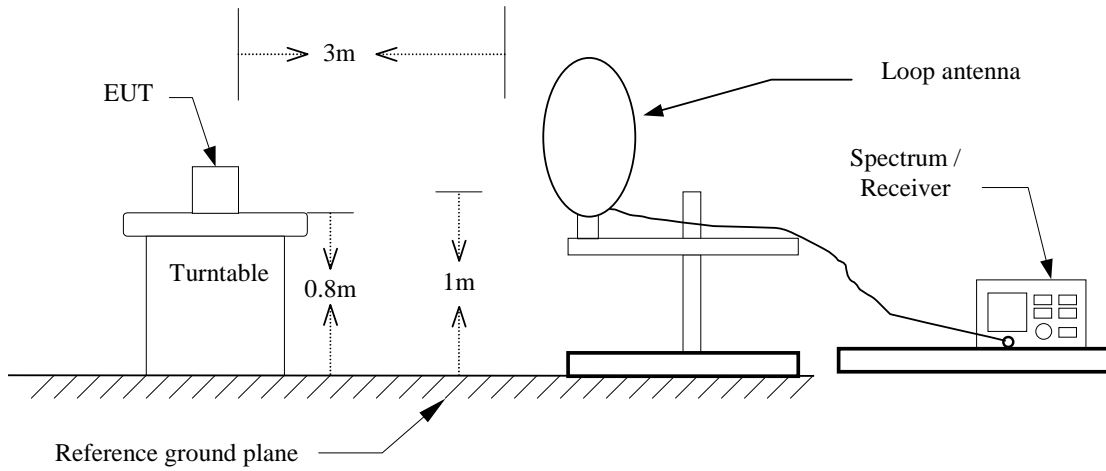

Below 1GHz

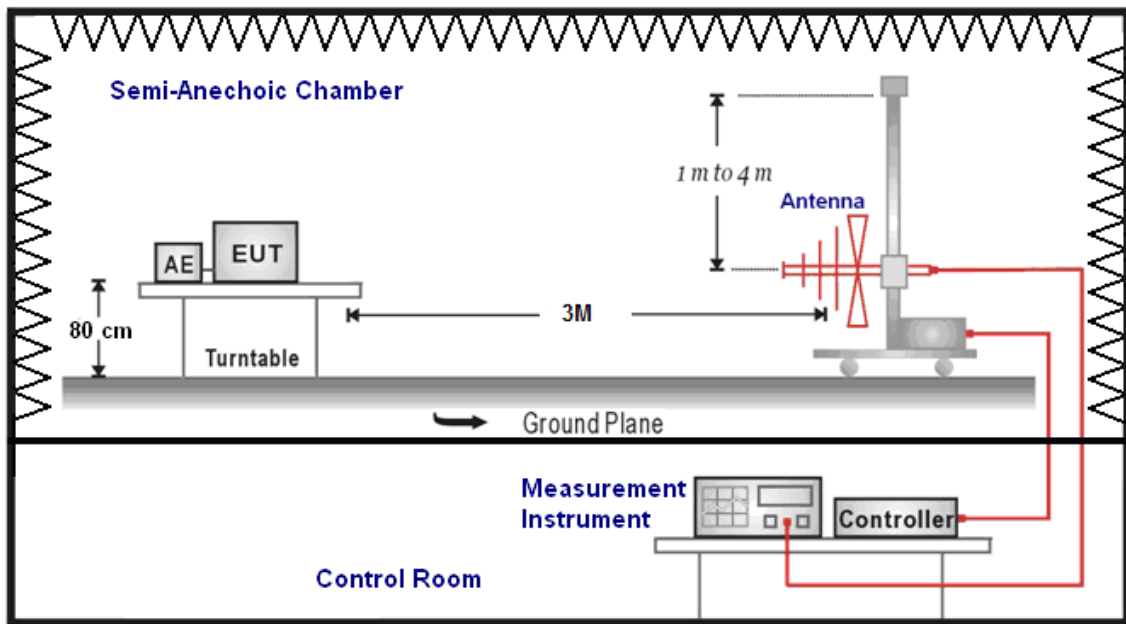

Above 1GHz

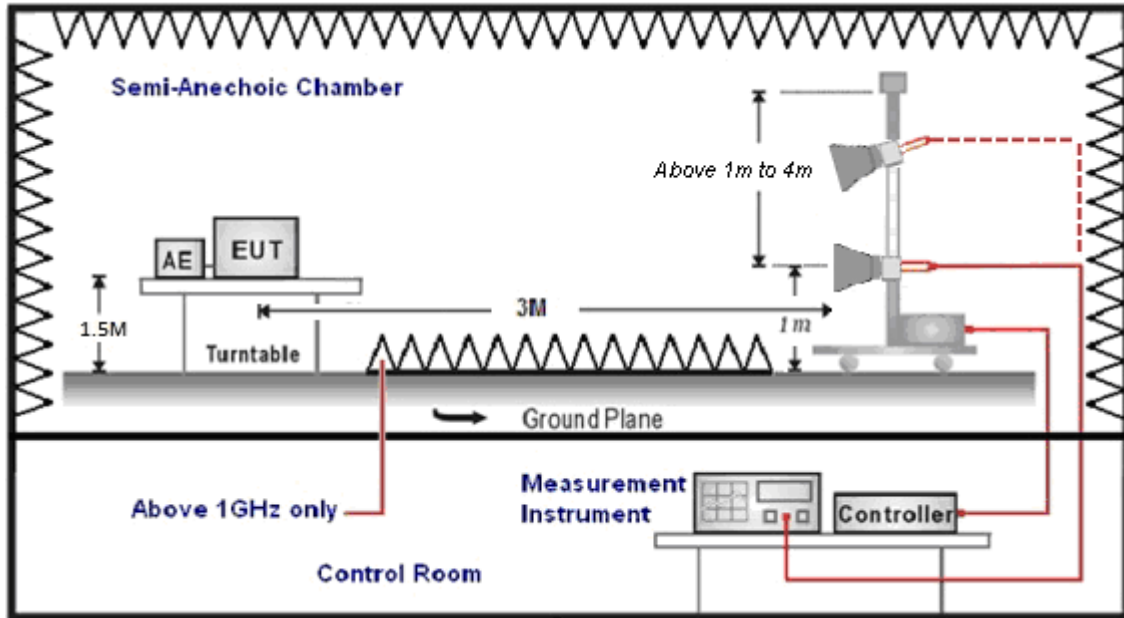

5.4. Test Procedure

Final radiation measurements were made on a three-meter, Semi Anechoic Chamber. The EUT system was placed on a nonconductive turntable which is 0.8 or 1.5 meters height (below 1GHz use 0.8m turntable / above 1GHz use 1.5m turntable), top surface 1.0 x 1.5 meter. The spectrum was examined from 250 MHz to 2.5 GHz in order to cover the whole spectrum below 10th harmonic which could generate from the EUT. During the test, EUT was set to transmit continuously & Measurements spectrum range from 9 kHz to 26.5 GHz is investigated.

For measurements below 1 GHz the resolution bandwidth is set to 100 kHz for peak detection measurements or 120 kHz for quasi-peak detection measurements. Peak detection is used unless otherwise noted as quasi-peak.

For measurements above 1 GHz the resolution bandwidth is set to 1 MHz, and then the video bandwidth is set to 1 MHz for peak measurements and 10 Hz for average measurements when Duty cycle >98% / 1/T for average measurements when Duty cycle <98%. A nonconductive material surrounded the EUT to supporting the EUT for standing on three orthogonal planes. At each condition, the EUT was rotated 360 degrees, and the antenna was raised and lowered from one to four meters to find the maximum emission levels. Measurements were taken using both horizontal and vertical antenna polarization.

SCHWARZBECK MESS-ELEKTRONIK Biconilog Antenna (mode VULB9163) at 3 Meter and the SCHWARZBECK Double Ridged Guide Antenna (model BBHA9120D&9170) was used in frequencies 1 – 26.5 GHz at a distance of 1 meter. All test results were extrapolated to equivalent signal at 3 meters utilizing an inverse linear distance extrapolation Factor (20dB/decade).

For testing above 1GHz, the emission level of the EUT in peak mode was 20dB lower than average limit (that means the emission level in peak mode also complies with the limit in average mode), then testing will be stopped and peak values of EUT will be reported, otherwise, the emissions will be measured in average mode again and reported.

Appropriate preamplifiers were used for improving sensitivity and precautions were taken to avoid overloading or desensitizing the spectrum analyzer. No post – detector video filters were used in the test.

The spectrum analyzer's 6 dB bandwidth was set to 1 MHz, and the analyzer was operated in the peak detection mode, for frequencies both below and up 1 GHz. The average levels were obtained by subtracting the duty cycle correction factor from the peak readings.

The following procedures were used to convert the emission levels measured in decibels referenced to 1 microvolt (dBuV) into field intensity in micro volts pre meter (uV/m).

The actual field intensity in decibels referenced to 1 microvolt in to field intensity in micro volts per meter (dBuV/m).

The actual field intensity in referenced to 1 microvolt per meter (dBuV/m) is determined by algebraically adding the measured reading in dBuV, the antenna factor (dB), and cable loss (dB) and Subtracting the gain of preamplifier (dB) is auto calculate in spectrum analyzer.

(1) $\text{Amplitude (dBuV/m)} = \text{FI (dBuV)} + \text{AF (dBuV)} + \text{CL (dBuV)} - \text{Gain (dB)}$

FI= Reading of the field intensity.

AF= Antenna factor.

CL= Cable loss.

P.S Amplitude is auto calculate in spectrum analyzer.

(2) $\text{Actual Amplitude (dBuV/m)} = \text{Amplitude (dBuV)} - \text{Dis(dB)}$

The FCC specified emission limits were calculated according the EUT operating frequency and by following linear interpolation equations:

(a) For fundamental frequency : Transmitter Output < +30dBm

(b) For spurious frequency : Spurious emission limits = fundamental emission limit /10

Data of measurement within this frequency range without mark in the table above means the reading of emissions are attenuated more than 20dB below the permissible limits or the field strength is too small to be measured.

5.5. Test Result

Below 1GHz

Standard:	FCC Part 15C	Test Distance:	3m
Test item:	Radiated Emission	Power:	AC 120V/60Hz
Model Number:	CLIP2 AN	Temp.(°C)/Hum.(%RH):	26(°C)/60%RH
Mode:	1	Date:	02/22/2016
		Test By:	Eric Ou Yang

Frequency (MHz)	Reading (dBuV)	Correct Factor (dB/m)	Result (dBuV/m)	Limit (dBuV/m)	Margin (dB)	Remark	Ant.Polar. H / V
180.5000	48.90	-17.21	31.69	43.50	-11.81	QP	H
258.0000	48.77	-16.50	32.27	46.00	-13.73	QP	H
323.0000	46.46	-14.42	32.04	46.00	-13.96	QP	H
399.5000	42.22	-12.38	29.84	46.00	-16.16	QP	H
516.0000	34.93	-9.93	25.00	46.00	-21.00	QP	H
908.0000	31.19	-3.74	27.45	46.00	-18.55	QP	H
180.0000	44.08	-17.16	26.92	43.50	-16.58	QP	V
258.0000	48.65	-16.50	32.15	46.00	-13.85	QP	V
399.5000	41.27	-12.38	28.89	46.00	-17.11	QP	V
516.5000	36.22	-9.93	26.29	46.00	-19.71	QP	V
710.5000	33.38	-6.60	26.78	46.00	-19.22	QP	V
797.0000	30.15	-5.38	24.77	46.00	-21.23	QP	V

Note: No emission found between lowest internal used/generated frequency to 30MHz (9kH~30MHz).

Above 1GHz

Standard:	FCC Part 15C			Test Distance:	3m		
Test item:	Radiated Emission			Power:	AC 120V/60Hz		
Model Number:	CLIP2 AN			Temp.(°C)/Hum.(%RH):	26(°C)/60%RH		
Mode:	2			Date:	02/22/2016		
Frequency:	2402MHz			Test By:	Eric Ou Yang		
Frequency (MHz)	Reading (dBuV)	Correct Factor (dB/m)	Result (dBuV/m)	Limit (dBuV/m)	Margin (dB)	Remark	Ant.Polar. H / V
3002.000	35.72	7.17	42.89	74.00	-31.11	peak	H
4647.000	34.00	10.41	44.41	74.00	-29.59	peak	H
6565.000	31.96	14.73	46.69	74.00	-27.31	peak	H
3198.000	35.63	7.33	42.96	74.00	-31.04	peak	V
4815.000	34.23	10.70	44.93	74.00	-29.07	peak	V
6712.000	32.84	14.89	47.73	74.00	-26.27	peak	V

Standard:	FCC Part 15C			Test Distance:	3m		
Test item:	Radiated Emission			Power:	AC 120V/60Hz		
Model Number:	CLIP2 AN			Temp.(°C)/Hum.(%RH):	26(°C)/60%RH		
Mode:	2			Date:	02/22/2016		
Frequency:	2440MHz			Test By:	Eric Ou Yang		
Frequency (MHz)	Reading (dBuV)	Correct Factor (dB/m)	Result (dBuV/m)	Limit (dBuV/m)	Margin (dB)	Remark	Ant.Polar. H / V
3170.000	35.09	7.31	42.40	74.00	-31.60	peak	H
4724.000	33.87	10.54	44.41	74.00	-29.59	peak	H
6824.000	32.22	15.01	47.23	74.00	-26.77	peak	H
3345.000	35.03	7.45	42.48	74.00	-31.52	peak	V
4633.000	34.29	10.38	44.67	74.00	-29.33	peak	V
6558.000	32.93	14.72	47.65	74.00	-26.35	peak	V

Standard:	FCC Part 15C			Test Distance:	3m		
Test item:	Radiated Emission			Power:	AC 120V/60Hz		
Model Number:	CLIP2 AN			Temp.(°C)/Hum.(%RH):	26(°C)/60%RH		
Mode:	2			Date:	02/22/2016		
Frequency:	2480MHz			Test By:	Eric Ou Yang		
Frequency (MHz)	Reading (dBuV)	Correct Factor (dB/m)	Result (dBuV/m)	Limit (dBuV/m)	Margin (dB)	Remark	Ant.Polar. H / V
3093.000	35.33	7.24	42.57	74.00	-31.43	peak	H
4682.000	33.93	10.46	44.39	74.00	-29.61	peak	H
6782.000	32.26	14.97	47.23	74.00	-26.77	peak	H
3296.000	35.84	7.41	43.25	74.00	-30.75	peak	V
4633.000	34.99	10.38	45.37	74.00	-28.63	peak	V
6656.000	32.11	14.83	46.94	74.00	-27.06	peak	V

Band Edge

Standard:	FCC Part 15C		Test Distance:	3m			
Test item:	Radiated Emission		Power:	AC 120V/60Hz			
Model Number:	CLIP2 AN		Temp.(°C)/Hum.(%RH):	26(°C)/60%RH			
Mode:	2		Date:	02/22/2016			
Frequency:	2402 MHz		Test By:	Eric Ou Yang			
Frequency (MHz)	Reading (dBuV)	Correct Factor (dB/m)	Result (dBuV/m)	Limit (dBuV/m)	Margin (dB)	Remark	Ant.Polar. H / V
2371.930	42.20	5.41	47.61	74.00	-26.39	peak	H
2390.000	40.15	5.45	45.60	74.00	-28.40	peak	H
2348.610	42.00	5.34	47.34	74.00	-26.66	peak	V
2390.000	39.80	5.45	45.25	74.00	-28.75	peak	V

Standard:	FCC Part 15C		Test Distance:	3m			
Test item:	Radiated Emission		Power:	AC 120V/60Hz			
Model Number:	CLIP2 AN		Temp.(°C)/Hum.(%RH):	26(°C)/60%RH			
Mode:	2		Date:	02/22/2016			
Frequency:	2480 MHz		Test By:	Eric Ou Yang			
Frequency (MHz)	Reading (dBuV)	Correct Factor (dB/m)	Result (dBuV/m)	Limit (dBuV/m)	Margin (dB)	Remark	Ant.Polar. H / V
2483.500	44.44	5.70	50.14	74.00	-23.86	peak	H
2483.720	44.36	5.70	50.06	74.00	-23.94	peak	H
2483.500	42.41	5.70	48.11	74.00	-25.89	peak	V
2483.800	42.92	5.70	48.62	74.00	-25.38	peak	V

6 Maximum Conducted Output Power Measurement

6.1. Limit

For systems using digital modulation in the 2400-2483.5MHz, the limit for peak output power is 30dBm.

6.2. Test Setup

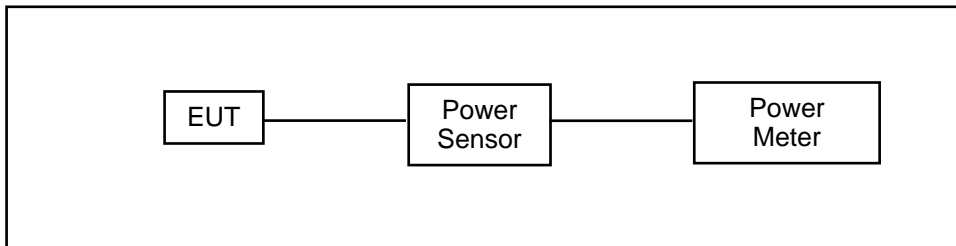

6.3. Test Instruments

Equipment	Manufacturer	Model Number	Serial Number	Cal. Date	Remark
Single Channel PK Power Sensor	Agilent	N1911A	MY45101619	12/11/2015	(1)
Wideband Power Meter	Agilent	N1921A	MY45241957	12/11/2015	(1)
Microwave Cable	EMCI	EMC104-SM-S M-1500	140303	02/24/2015	(1)
Test Site	ATL	TE05	TE05	N.C.R.	-----

Remark: (1) Calibration period 1 year. (2) Calibration period 2 years. (3) Calibration period 3 years.

Note: N.C.R. = No Calibration Request.

6.4. Test Procedure

The tests below are run with the EUT's transmitter set at high power in TX mode. The EUT is needed to force selection of output power level and channel number. While testing, EUT was set to transmit continuously. Remove the Subjective device's antenna and connect the RF output port to power sensor. The maximum peak output power shall not exceed 1 watt.

Use a direct connection between the antenna port of transmitter and the power sensor, for prevent the power sensor input attenuation 40-50 dB. Set the RBW Bandwidth of the emission or use a channel power meter mode.

For antennas with gains of 6 dBi or less, maximum allowed transmitter output is 1 watt (+30 dBm). For antennas with gains greater than 6 dBi, transmitter output level must be decreased by an amount equal to $(\text{GAIN} - 6)/3$ dBm.

The antenna port of the EUT was connected to the input of a power sensor. Power was read directly and cable loss correction was added to the reading to obtain power at the EUT antenna terminals.

6.5. Test Result

Model Number	CLIP2 AN					
Test Item	Maximum Conducted Output Power					
Test Mode	Mode 2: Bluetooth LE TX Mode					
Date of Test	02/22/2016			Test Site	TE05	
Frequency (MHz)	Data Rate	Average Power		Peak Power		Limit (dBm)
		(dBm)	(W)	(dBm)	(W)	
2402	---	1.83	0.00152	2.55	0.00180	< 30
2440	---	1.71	0.00148	2.82	0.00191	< 30
2480	---	2.32	0.00171	3.75	0.00237	< 30

Note: The relevant measured result has the offset with cable loss already.

7 6dB RF Bandwidth Measurement

7.1. Limit

6dB RF Bandwidth: Systems using digital modulation techniques may operate in the 2400–2483.5 MHz bands. The minimum 6 dB band-width shall be at least 500 kHz.

7.2. Test Setup

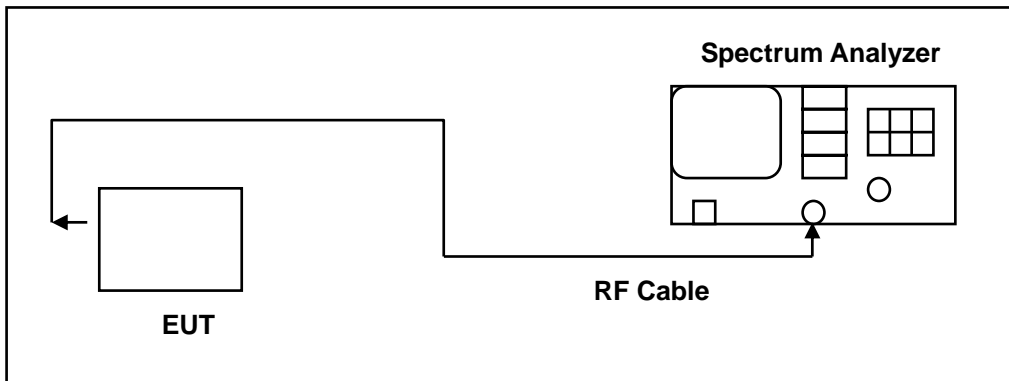

7.3. Test Instruments

Equipment	Manufacturer	Model Number	Serial Number	Cal. Date	Remark
Spectrum Analyzer	Agilent	E4445A	MY45300744	12/15/2015	(1)
Microwave Cable	EMCI	EMC104-SM-S M-1500	140303	02/24/2015	(1)
Test Site	ATL	TE05	TE05	N.C.R.	-----

dRemark: (1) Calibration period 1 year. (2) Calibration period 2 years. (3) Calibration period 3 years.

Note: N.C.R. = No Calibration Request.

7.4. Test Procedure

The EUT tested to DTS test procedure of KDB558074D01 for compliance to FCC 47CFR 15.247 requirements.

6dB RF Bandwidth: The antenna port of the EUT was connected to the input of a spectrum analyzer. Analyzer RBW was set to 100 kHz. For each RF output channel investigated, the spectrum analyzer center frequency was set to the channel carrier. A peak output reading was taken, a DISPLAY line was drawn 6 dB lower than peak level. The 6 dB bandwidth was determined from where the channel output spectrum intersected the display line.

The test was performed at 3 channels (Channel low, middle, high)

7.5. Test Result

Model Number	CLIP2 AN		
Test Item	6dB RF Bandwidth		
Test Mode	Mode 2: Bluetooth LE TX Mode		
Date of Test	02/04/2016	Test Site	TE05
Frequency (MHz)	6dB Bandwidth (kHz)	6dB RF Bandwidth Limit (kHz)	
2402	702.1	> 500	
2440	694.1	> 500	
2480	687.0	> 500	

7.6. Test Graphs

Mode 2: Bluetooth LE TX Mode	
2402 MHz	<p>Agilent Spectrum Analyzer - Occupied BW</p> <p>Center Freq: 2.402000000 GHz</p> <p>Center Freq: 2.402000000 GHz</p> <p>Trig: Free Run</p> <p>Avg/Hold: >10/10</p> <p>Radio Std: None</p> <p>Radio Device: BTS</p> <p>10 dB/div Ref 20.00 dBm</p> <p>Center 2.402 GHz</p> <p>#Res BW 100 kHz</p> <p>#VBW 300 kHz</p> <p>Span 3 MHz</p> <p>Sweep 1 ms</p> <p>Occupied Bandwidth 1.0485 MHz</p> <p>Total Power 6.30 dBm</p> <p>Transmit Freq Error 9.279 kHz</p> <p>OBW Power 99.00 %</p> <p>x dB Bandwidth 702.1 kHz</p> <p>x dB -6.00 dB</p> <p>Frequency</p> <p>Center Freq 2.402000000 GHz</p> <p>CF Step 300.000 kHz</p> <p>Man</p> <p>Freq Offset 0 Hz</p>
2440 MHz	<p>Agilent Spectrum Analyzer - Occupied BW</p> <p>Center Freq: 2.440000000 GHz</p> <p>Center Freq: 2.440000000 GHz</p> <p>Trig: Free Run</p> <p>Avg/Hold: >10/10</p> <p>Radio Std: None</p> <p>Radio Device: BTS</p> <p>10 dB/div Ref 20.00 dBm</p> <p>Center 2.44 GHz</p> <p>#Res BW 100 kHz</p> <p>#VBW 300 kHz</p> <p>Span 3 MHz</p> <p>Sweep 1 ms</p> <p>Occupied Bandwidth 1.0401 MHz</p> <p>Total Power 7.45 dBm</p> <p>Transmit Freq Error 2.560 kHz</p> <p>OBW Power 99.00 %</p> <p>x dB Bandwidth 694.1 kHz</p> <p>x dB -6.00 dB</p> <p>Frequency</p> <p>Center Freq 2.440000000 GHz</p> <p>CF Step 300.000 kHz</p> <p>Man</p> <p>Freq Offset 0 Hz</p>
2480 MHz	<p>Agilent Spectrum Analyzer - Occupied BW</p> <p>Center Freq: 2.480000000 GHz</p> <p>Center Freq: 2.480000000 GHz</p> <p>Trig: Free Run</p> <p>Avg/Hold: >10/10</p> <p>Radio Std: None</p> <p>Radio Device: BTS</p> <p>10 dB/div Ref 20.00 dBm</p> <p>Center 2.48 GHz</p> <p>#Res BW 100 kHz</p> <p>#VBW 300 kHz</p> <p>Span 3 MHz</p> <p>Sweep 1 ms</p> <p>Occupied Bandwidth 1.0422 MHz</p> <p>Total Power 8.08 dBm</p> <p>Transmit Freq Error 2.700 kHz</p> <p>OBW Power 99.00 %</p> <p>x dB Bandwidth 687.0 kHz</p> <p>x dB -6.00 dB</p> <p>Frequency</p> <p>Center Freq 2.480000000 GHz</p> <p>CF Step 300.000 kHz</p> <p>Man</p> <p>Freq Offset 0 Hz</p>

8 Maximum Power Density Measurement

8.1. Limit

For digitally modulated systems, the power spectral density conducted from the intentional radiator to the antenna shall not be greater than 8 dBm in any 3 kHz band during any time interval of continuous transmission.

8.2. Test Setup

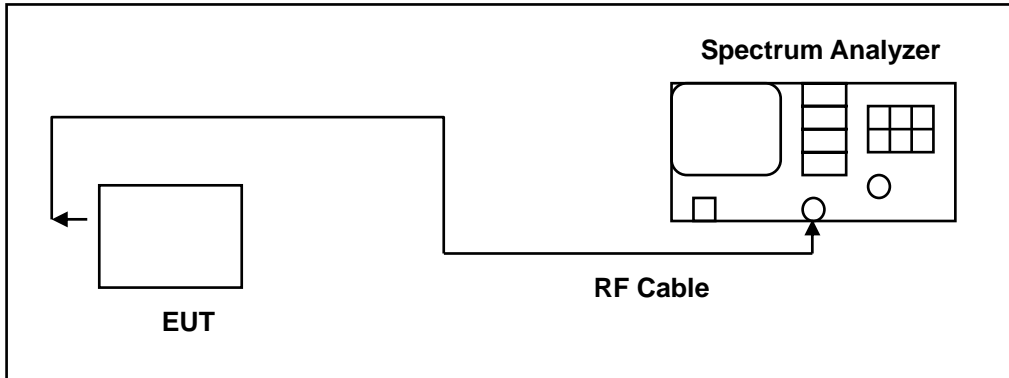

8.3. Test Instruments

Equipment	Manufacturer	Model Number	Serial Number	Cal. Date	Remark
Spectrum Analyzer	Agilent	E4445A	MY45300744	12/15/2015	(1)
Microwave Cable	EMCI	EMC104-SM-S M-1500	140303	02/24/2015	(1)
Test Site	ATL	TE05	TE05	N.C.R.	-----

Remark: (1) Calibration period 1 year. (2) Calibration period 2 years. (3) Calibration period 3 years.

Note: N.C.R. = No Calibration Request.

8.4. Test Procedure

The EUT tested to DTS test procedure of KDB558074D01 for compliance to FCC 47CFR 15.247 requirements.

1. Set analyzer center frequency to DTS channel center frequency.
2. Set the span to 1.5 times the DTS bandwidth.
3. Set the RBW to: $3 \text{ kHz} \leq \text{RBW} \leq 100 \text{ kHz}$.
4. Set the VBW $\geq 3 \times \text{RBW}$.
5. Detector = peak.
6. Sweep time = auto couple.
7. Trace mode = max hold.
8. Allow trace to fully stabilize.
9. Use the peak marker function to determine the maximum amplitude level within the RBW.
10. If measured value exceeds limit, reduce RBW (no less than 3 kHz) and repeat.

Remark: Peak detector is used.

8.5. Test Result

Model Number	CLIP2 AN		
Test Item	Maximum Power Density		
Test Mode	Mode 2: Bluetooth LE TX Mode		
Date of Test	02/22/2016	Test Site	TE05
Frequency (MHz)	Reading (dBm/3KHz)		Limit (dBm)
2402	-14.17		< 8
2440	-15.00		< 8
2480	-16.43		< 8

8.6. Test Graphs

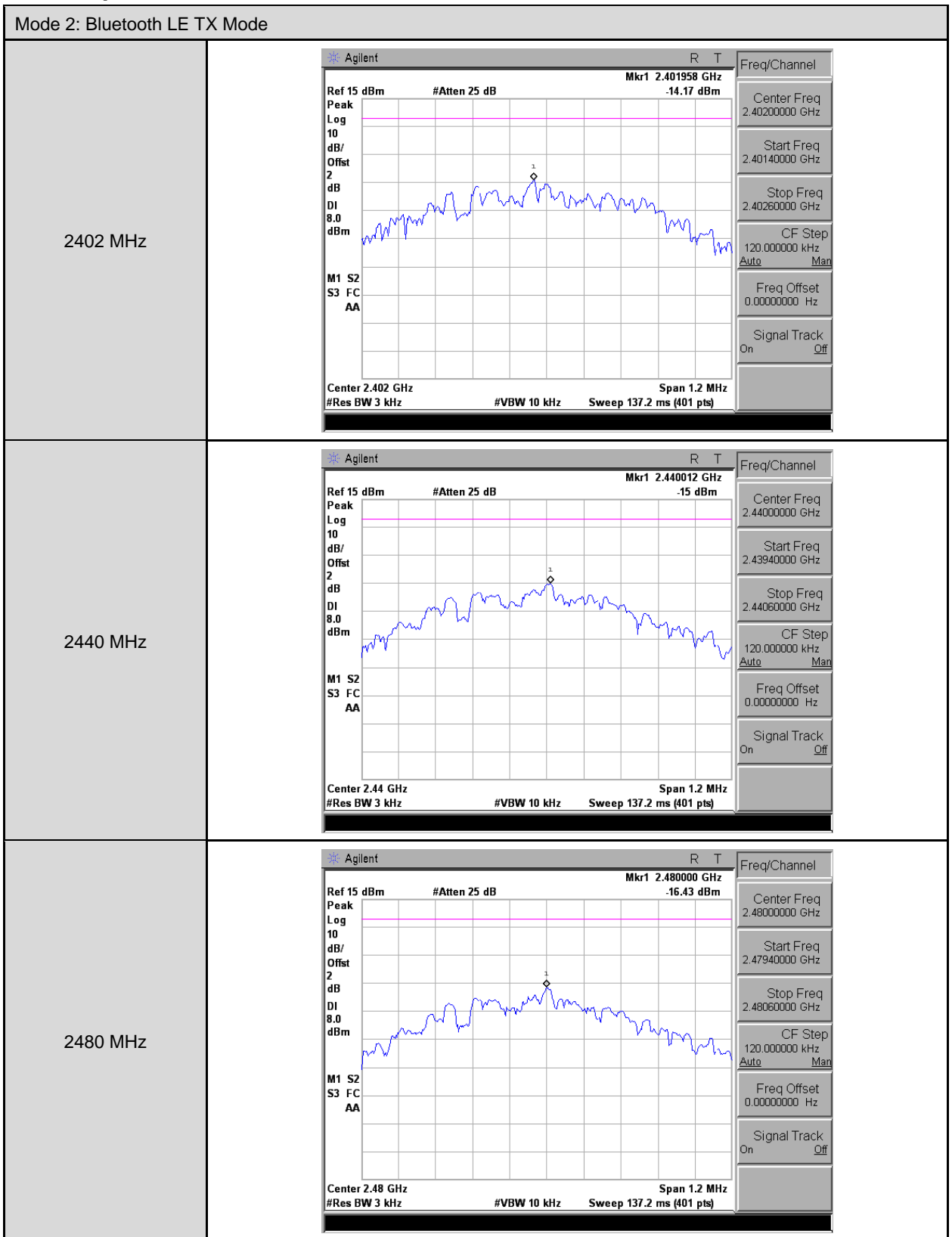

9 Out of Band Conducted Emissions Measurement

9.1. Limit

In any 100 kHz bandwidth outside the frequency band in which the spread spectrum or digitally modulated intentional radiator is operating, the radio frequency power that is produced by the intentional radiator shall be at least 20 dB below that in the 100 kHz bandwidth within the band that contains the highest level of the desired power

9.2. Test Setup

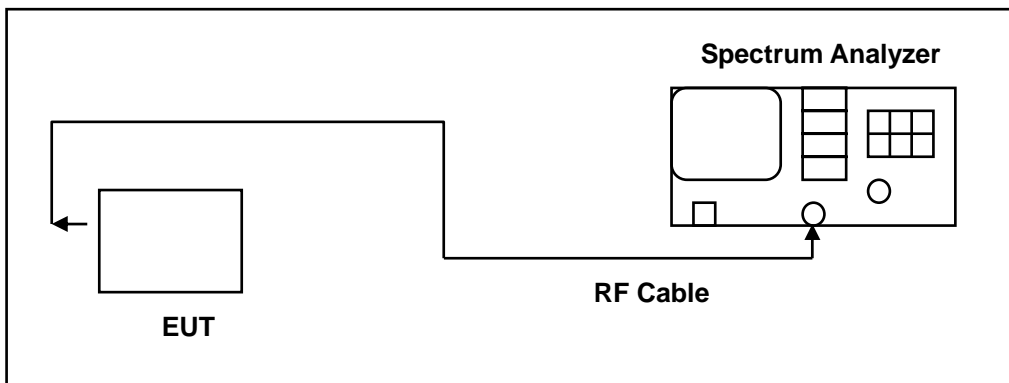

9.3. Test Instruments

Equipment	Manufacturer	Model Number	Serial Number	Cal. Date	Remark
Spectrum Analyzer	Agilent	E4445A	MY45300744	12/15/2015	(1)
Spectrum Analyzer	Agilent	E4408B	MY45107753	07/27/2015	(1)
Microwave Cable	EMCI	EMC104-SM-S M-1500	140303	02/24/2015	(1)
Test Site	ATL	TE05	TE05	N.C.R.	-----

Remark: (1) Calibration period 1 year.

Note: N.C.R. = No Calibration Request.

9.4. Test Procedure

In any 100 kHz bandwidth outside the EUT pass band, the RF power produced by the modulation products of the spreading sequence, the information sequence, and the carrier frequency shall be at least 20 dB below that of the maximum in-band 100 kHz emission, antenna output of the EUT was coupled directly to spectrum analyzer; if an external attenuator and/or cable was used, these losses are compensated for with the analyzer OFFSET function.

All other types of emissions from the EUT shall meet the general limits for radiated frequencies outside the pass band.

The test was performed at 3 channels.

9.5. Test Graphs

Reference level

Date of Test 02/22/2016

Mode 2: Bluetooth LE TX Mode	
2402 MHz	
2440 MHz	
2480 MHz	

Out of Band Conducted Emissions

Mode 2: Bluetooth LE TX Mode

2402 MHz

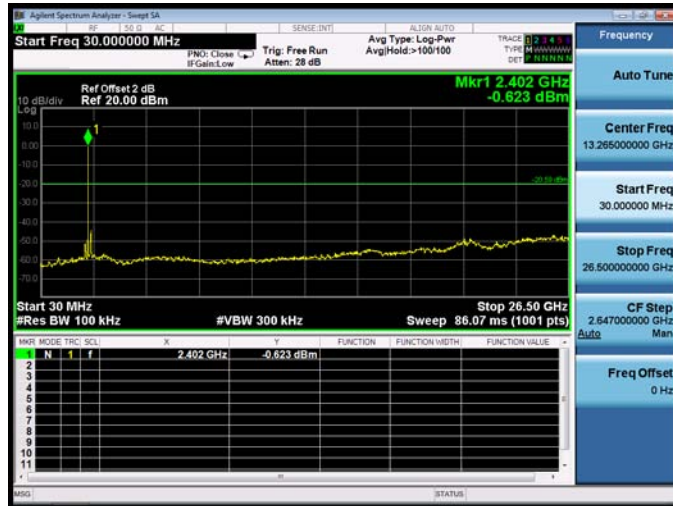

2440 MHz

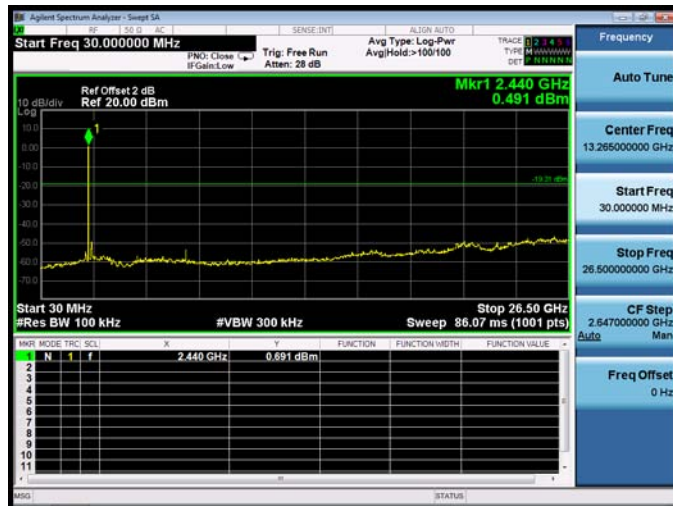

2480 MHz

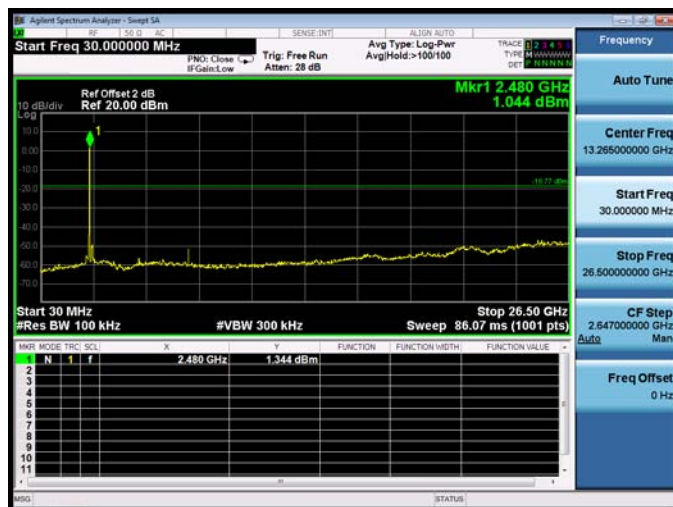

Conducted Band Edge

Mode 2: Bluetooth LE TX Mode

2402 MHz

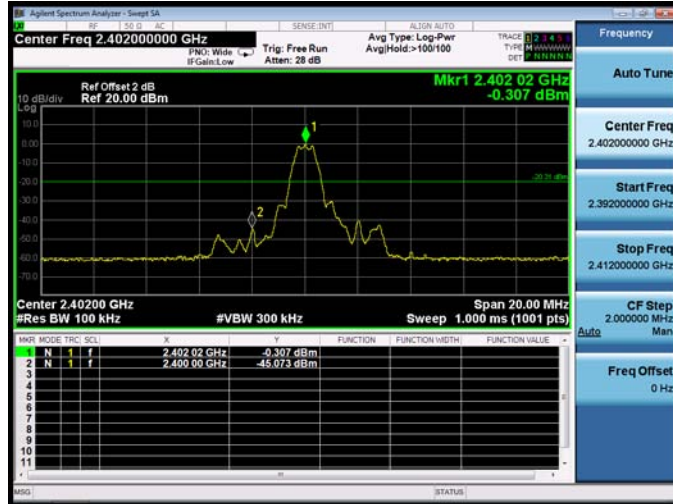

2480 MHz

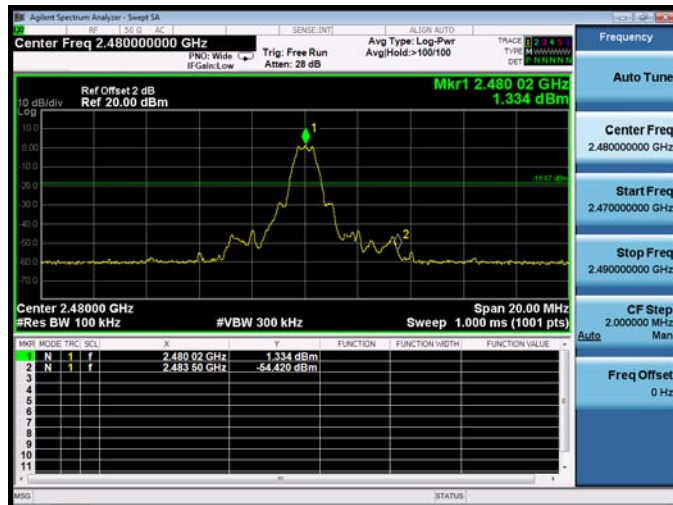

10 Antenna Measurement

10.1.Limit

For intentional device, according to 15.203, an intentional radiator shall be designed to ensure that no antenna other than that furnished by the responsible party shall be used with the device.

And According to 15.247 (b), if transmitting antennas of directional gain greater than 6 dBi are used, the power shall be reduced by the amount in dB that the directional gain of the antenna exceeds 6dBi.

10.2.Antenna Connector Construction

The antenna used in this product is PCB Antenna. And the maximum Gain of this antenna is 0 dBi.