



FCC RADIO TEST REPORT

FCC ID: APIHKOMNI20

Product : Streaming wireless speaker

Trade Name : harman/kardon

Model Name : HK OMNI 20

Serial Model : N/A

Report No. : NTEK-2014DC0523061F1

Prepared for

Harman International Industries, Incorporated.

8500 Balboa Blvd, Northridge, CA 91329, United States

Prepared by

Shenzhen NTEK Testing Technology Co., Ltd.

1/F, Building E, Fenda Science Park, Sanwei Community, Xixiang Street
Bao'an District, Shenzhen P.R. China

Tel.: +86-0755-61156588 Fax.: +86-0755-61156599

Website: www.ntek.org.cn

Table of Contents

	Page
1 . SUMMARY OF TEST RESULTS	5
1.1 TEST FACILITY	6
1.2 MEASUREMENT UNCERTAINTY	6
2 . GENERAL INFORMATION	7
2.1 GENERAL DESCRIPTION OF EUT	7
2.2 DESCRIPTION OF TEST MODES	9
2.3 BLOCK DIGRAM SHOWING THE CONFIGURATION OF SYSTEM TESTED	10
2.4 DESCRIPTION OF SUPPORT UNITS(CONDUCTED MODE)	11
2.5 EQUIPMENTS LIST FOR ALL TEST ITEMS	12
3 . EMC EMISSION TEST	13
3.1 CONDUCTED EMISSION MEASUREMENT	13
3.1.1 POWER LINE CONDUCTED EMISSION LIMITS	13
3.1.2 TEST PROCEDURE	14
3.1.3 DEVIATION FROM TEST STANDARD	14
3.1.4 TEST SETUP	14
3.1.5 EUT OPERATING CONDITIONS	14
3.1.6 TEST RESULTS	15
3.2 RADIATED EMISSION MEASUREMENT	19
3.2.1 RADIATED EMISSION LIMITS	19
3.2.2 TEST PROCEDURE	20
3.2.3 DEVIATION FROM TEST STANDARD	20
3.2.4 TEST SETUP	21
3.2.5 EUT OPERATING CONDITIONS	22
3.2.6 TEST RESULTS (BETWEEN 9KHZ – 30 MHZ)	23
3.2.7 TEST RESULTS (BETWEEN 30MHZ – 1GHZ)	24
3.2.8 TEST RESULTS (ABOVE 1000 MHZ)	27
4 . POWER SPECTRAL DENSITY TEST	47
4.1 APPLIED PROCEDURES / LIMIT	47
4.1.1 TEST PROCEDURE	47
4.1.2 DEVIATION FROM STANDARD	47
4.1.3 TEST SETUP	47
4.1.4 EUT OPERATION CONDITIONS	47
4.1.5 TEST RESULTS	48
5 . BANDWIDTH TEST	60
5.1 APPLIED PROCEDURES / LIMIT	60
5.1.1 TEST PROCEDURE	60

Table of Contents

	Page
5.1.2 EUT OPERATION CONDITIONS	60
5.1.3 TEST RESULTS	61
6 . PEAK OUTPUT POWER TEST	73
6.1 APPLIED PROCEDURES / LIMIT	73
6.1.1 TEST PROCEDURE	73
6.1.2 DEVIATION FROM STANDARD	73
6.1.3 TEST SETUP	73
6.1.4 EUT OPERATION CONDITIONS	73
6.1.5 TEST RESULTS	74
7 . 100 KHZ BANDWIDTH OF FREQUENCY BAND EDGE	76
7.1 DEVIATION FROM STANDARD	76
7.2 TEST SETUP	76
7.3 EUT OPERATION CONDITIONS	76
7.4 TEST RESULTS	77
8 . ANTENNA REQUIREMENT	87
8.1 STANDARD REQUIREMENT	87
8.2 EUT ANTENNA	87
APPENDIX-PHOTOGRAPHS OF EUT CONSTRUCTIONAL DETAILS	

1. SUMMARY OF TEST RESULTS

Test procedures according to the technical standards:

FCC Part15 (15.247) , Subpart C			
Standard Section	Test Item	Judgment	Remark
15.207	Conducted Emission	PASS	
15.247 (a)(2)	6dB Bandwidth	PASS	
15.247 (b)	Peak Output Power	PASS	
15.247 (c)	Radiated Spurious Emission	PASS	
15.247 (d)	Power Spectral Density	PASS	
15.205	Band Edge Emission	PASS	
15.203	Antenna Requirement	PASS	

NOTE:

(1) "N/A" denotes test is not applicable in this Test Report

1.1 TEST FACILITY

NTEK Testing Technology Co., Ltd
 Add.:1/F, Building E, Fenda Science Park, Sanwei Community, Xixiang Street, Bao'an District, Shenzhen P.R. China.
 FCC Registration No.:238937; IC Registration No.:9270A-1
 CNAS Registration No.:L5516

1.2 MEASUREMENT UNCERTAINTY

The reported uncertainty of measurement $y \pm U$, where expanded uncertainty U is based on a standard uncertainty multiplied by a coverage factor of $k=2$, providing a level of confidence of approximately 95 %.

No.	Item	Uncertainty
1	Conducted Emission Test	$\pm 1.38\text{dB}$
2	RF power,conducted	$\pm 0.16\text{dB}$
3	Spurious emissions,conducted	$\pm 0.21\text{dB}$
4	All emissions,radiated(<1G)	$\pm 4.68\text{dB}$
5	All emissions,radiated(>1G)	$\pm 4.89\text{dB}$
6	Temperature	$\pm 0.5^\circ\text{C}$
7	Humidity	$\pm 2\%$

2. GENERAL INFORMATION

2.1 GENERAL DESCRIPTION OF EUT

Equipment	Streaming wireless speaker	
Trade Name	harman/kardon	
Model Name	HK OMNI 20	
Serial Model	N/A	
Model Difference	N/A	
Product Description	The EUT is a Streaming wireless speaker	
	Operation Frequency:	802.11b/g/n(20MHz): 2412~2462MHz
	Modulation Type:	CCK/OFDM/DBPSK
	Bit Rate of Transmitter	802.11b:11/5.5/2/1 Mbps 802.11g:54/48/36/24/18/12/9/6Mbps 802.11n(20MHz):150/144.44/130/117/115.56/104/86.67/78/52/6.5Mbps
	Number Of Channel	802.11b/g/n20MHz:11CH
	Antenna Designation:	Please see Note 3.
	Output Power(Conducted):	Ant A: 802.11b: 12.32 dBm (Max.) 802.11g: 11.42 dBm (Max.) 802.11n(20M): 10.51 dBm (Max.) Ant B: 802.11b: 12.53 dBm (Max.) 802.11g: 11.42 dBm (Max.) 802.11n(20M): 10.62 dBm (Max.)
	Antenna Gain (dBi)	Ant A:3.12 dbi Ant B:3.34 dbi
	Based on the application, features, or specification exhibited in User's Manual, the EUT is considered as an ITE/Computing Device. More details of EUT technical specification, please refer to the User's Manual.	
	Channel List	Please refer to the Note 2.
Ratings	AC100-240V,50/60Hz	
Adapter	N/A	
Battery	N/A	

Note:

1. For a more detailed features description, please refer to the manufacturer's specifications or the User's Manual.

2.

Channel List for 802.11b/g/n(20 MHz)							
Channel	Frequency (MHz)	Channel	Frequency (MHz)	Channel	Frequency (MHz)	Channel	Frequency (MHz)
01	2412	04	2427	07	2442	10	2457
02	2417	05	2432	08	2447	11	2462
03	2422	06	2437	09	2452		

3.

Table for Filed Antenna

Ant	Brand	Model Name	Antenna Type	Connector	Gain (dBi)	NOTE
A	N/A	N/A	PCB Antenna	N/A	3.12	Wifi Antenna
B	N/A	N/A	PCB Antenna	N/A	3.34	Wifi Antenna

2.2 DESCRIPTION OF TEST MODES

To investigate the maximum EMI emission characteristics generates from EUT, the test system was pre-scanning tested base on the consideration of following EUT operation mode or test configuration mode which possible have effect on EMI emission level. Each of these EUT operation mode(s) or test configuration mode(s) mentioned above was evaluated respectively.

Pretest Mode	Description
Mode 1	802.11b CH1/ CH6/ CH11
Mode 2	802.11g CH1/ CH6/ CH11
Mode 3	802.11n/20MHz CH1/ CH6/ CH11
Mode 4	Link Mode

For Conducted Emission	
Final Test Mode	Description
Mode 4	Link Mode

For Radiated Emission	
Final Test Mode	Description
Mode 1	802.11b CH1/ CH6/ CH11
Mode 2	802.11g CH1/ CH6/ CH11
Mode 3	802.11n/20MHz CH1/ CH6/ CH11

Note:

- (1) The measurements are performed at the highest, middle, lowest available channels.
- (2) The measurements are performed at all Bit Rate of Transmitter, the worst data was reported

2.3 BLOCK DIGRAM SHOWING THE CONFIGURATION OF SYSTEM TESTED

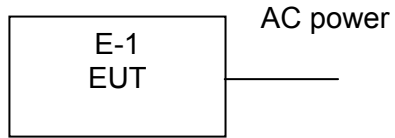

2.4 DESCRIPTION OF SUPPORT UNITS(CONDUCTED MODE)

The EUT has been tested as an independent unit together with other necessary accessories or support units. The following support units or accessories were used to form a representative test configuration during the tests.

Item	Equipment	Brand	Model/Type No.	Series No.	Note
E-1	Streaming wireless speaker	harman/kardon	HK OMNI 20	N/A	EUT

Item	Shielded Type	Ferrite Core	Length	Note

Note:

- (1) The support equipment was authorized by Declaration of Confirmation.
- (2) For detachable type I/O cable should be specified the length in cm in 『Length』 column.

2.5 EQUIPMENTS LIST FOR ALL TEST ITEMS

Radiation Test equipment

Item	Kind of Equipment	Manufacturer	Type No.	Serial No.	Last calibration	Calibrated until	Calibration period
1	Spectrum Analyzer	Agilent	E4407B	MY45108040	2013.07.06	2014.07.05	1 year
2	Test Receiver	R&S	ESPI	101318	2014.06.07	2015.06.06	1 year
3	Bilog Antenna	TESEQ	CBL6111D	31216	2013.07.06	2014.07.05	1 year
4	50Ω Coaxial Switch	Anritsu	MP59B	6200264416	2014.06.07	2015.06.06	1 year
5	Spectrum Analyzer	ADVANTEST	R3132	150900201	2014.06.07	2015.06.06	1 year
6	Horn Antenna	EM	EM-AH-10180	2011071402	2013.07.06	2014.07.05	1 year
7	Horn Ant	Schwarzbeck	BBHA 9170	9170-181	2013.07.06	2014.07.05	1 year
8	Amplifier	EM	EM-30180	060538	2013.12.22	2014.12.21	1 year
9	Loop Antenna	ARA	PLA-1030/B	1029	2014.06.08	2015.06.07	1 year
10	Power Meter	R&S	NRVS	100696	2013.07.06	2014.07.05	1 year
11	Power Sensor	R&S	URV5-Z4	0395.1619.05	2013.07.06	2014.07.05	1 year

Conduction Test equipment

Item	Kind of Equipment	Manufacturer	Type No.	Serial No.	Last calibration	Calibrated until	Calibration period
1	Test Receiver	R&S	ESCI	101160	2014.06.06	2015.06.05	1 year
2	LISN	R&S	ENV216	101313	2013.08.24	2014.08.23	1 year
3	LISN	EMCO	3816/2	00042990	2013.08.24	2014.08.23	1 year
4	50Ω Coaxial Switch	Anritsu	MP59B	6200264417	2014.06.07	2015.06.06	1 year
5	Passive Voltage Probe	R&S	ESH2-Z3	100196	2014.06.07	2015.06.06	1 year
6	Absorbing clamp	R&S	MOS-21	100423	2014.06.08	2015.06.07	1 year

1	Attenuation	MCE	24-10-34	BN9258	2014.06.08	2015.06.07	1 year
---	-------------	-----	----------	--------	------------	------------	--------

3. EMC EMISSION TEST

3.1 CONDUCTED EMISSION MEASUREMENT

3.1.1 POWER LINE CONDUCTED EMISSION Limits (Frequency Range 150KHz-30MHz)

FREQUENCY (MHz)	Class A (dBuV)		Class B (dBuV)		Standard
	Quasi-peak	Average	Quasi-peak	Average	
0.15 -0.5	79.00	66.00	66 - 56 *	56 - 46 *	CISPR
0.50 -5.0	73.00	60.00	56.00	46.00	CISPR
5.0 -30.0	73.00	60.00	60.00	50.00	CISPR

0.15 -0.5	79.00	66.00	66 - 56 *	56 - 46 *	FCC
0.50 -5.0	73.00	60.00	56.00	46.00	FCC
5.0 -30.0	73.00	60.00	60.00	50.00	FCC

Note:

- (1) The tighter limit applies at the band edges.
- (2) The limit of " * " marked band means the limitation decreases linearly with the logarithm of the frequency in the range.

The following table is the setting of the receiver

Receiver Parameters	Setting
Attenuation	10 dB
Start Frequency	0.15 MHz
Stop Frequency	30 MHz
IF Bandwidth	9 kHz

3.1.2 TEST PROCEDURE

- a. The EUT was placed 0.8 meters from the horizontal ground plane with EUT being connected to the power mains through a line impedance stabilization network (LISN). All other support equipments powered from additional LISN(s). The LISN provide 50 Ohm/ 50uH of coupling impedance for the measuring instrument.
- b. Interconnecting cables that hang closer than 40 cm to the ground plane shall be folded back and forth in the center forming a bundle 30 to 40 cm long.
- c. I/O cables that are not connected to a peripheral shall be bundled in the center. The end of the cable may be terminated, if required, using the correct terminating impedance. The overall length shall not exceed 1 m.
- d. LISN at least 80 cm from nearest part of EUT chassis.
- e. For the actual test configuration, please refer to the related Item –EUT Test Photos.

3.1.3 DEVIATION FROM TEST STANDARD

No deviation

3.1.4 TEST SETUP

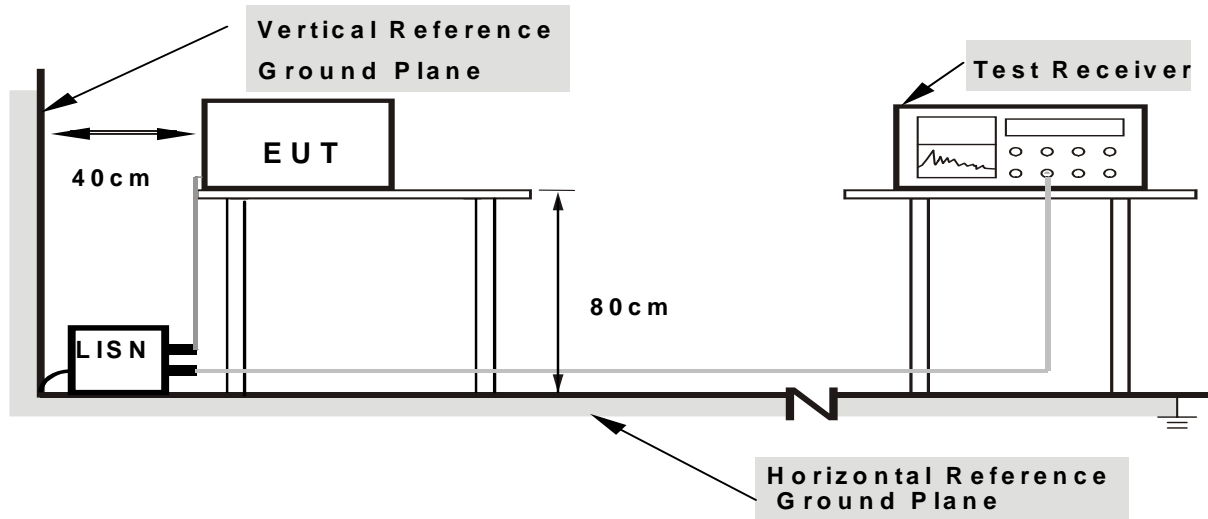

- Note:**
- 1. Support units were connected to second LISN.
 - 2. Both of LISNs (AMN) are 80 cm from EUT and at least 80 from other units and other metal planes

3.1.5 EUT OPERATING CONDITIONS

The EUT was configured for testing in a typical fashion (as a customer would normally use it). The EUT has been programmed to continuously transmit during test. This operating condition was tested and used to collect the included data.

3.1.6 TEST RESULTS

EUT :	Streaming wireless speaker	Model Name. :	HK OMNI 20
Temperature :	26 °C	Relative Humidity :	56%
Pressure :	1010hPa	Phase :	L
Test Voltage :	AC 120V/60Hz	Test Mode :	Mode 4-Ant A

Frequency (MHz)	Meter Reading (dBμV)	Factor (dB)	Emission Level (dBμV)	Limits (dBμV)	Margin (dB)	Detector Type
0.1940	34.80	11.14	45.94	63.86	-17.92	QP
0.1940	24.57	11.14	35.71	53.86	-18.15	AVG
0.4620	32.39	10.63	43.02	56.66	-13.64	QP
0.4620	20.45	10.63	31.08	46.66	-15.58	AVG
0.7420	23.87	10.53	34.40	56.00	-21.60	QP
0.7420	18.59	10.53	29.12	46.00	-16.88	AVG
2.0860	23.95	10.52	34.47	56.00	-21.53	QP
2.0860	20.06	10.52	30.58	46.00	-15.42	AVG
3.3020	31.16	10.56	41.72	56.00	-14.28	QP
3.3020	22.16	10.56	32.72	46.00	-13.28	AVG
7.4299	28.34	10.74	39.08	60.00	-20.92	QP
7.4299	17.96	10.74	28.70	50.00	-21.30	AVG

Remark:

1. All readings are Quasi-Peak and Average values.
2. Factor = Insertion Loss + Cable Loss.

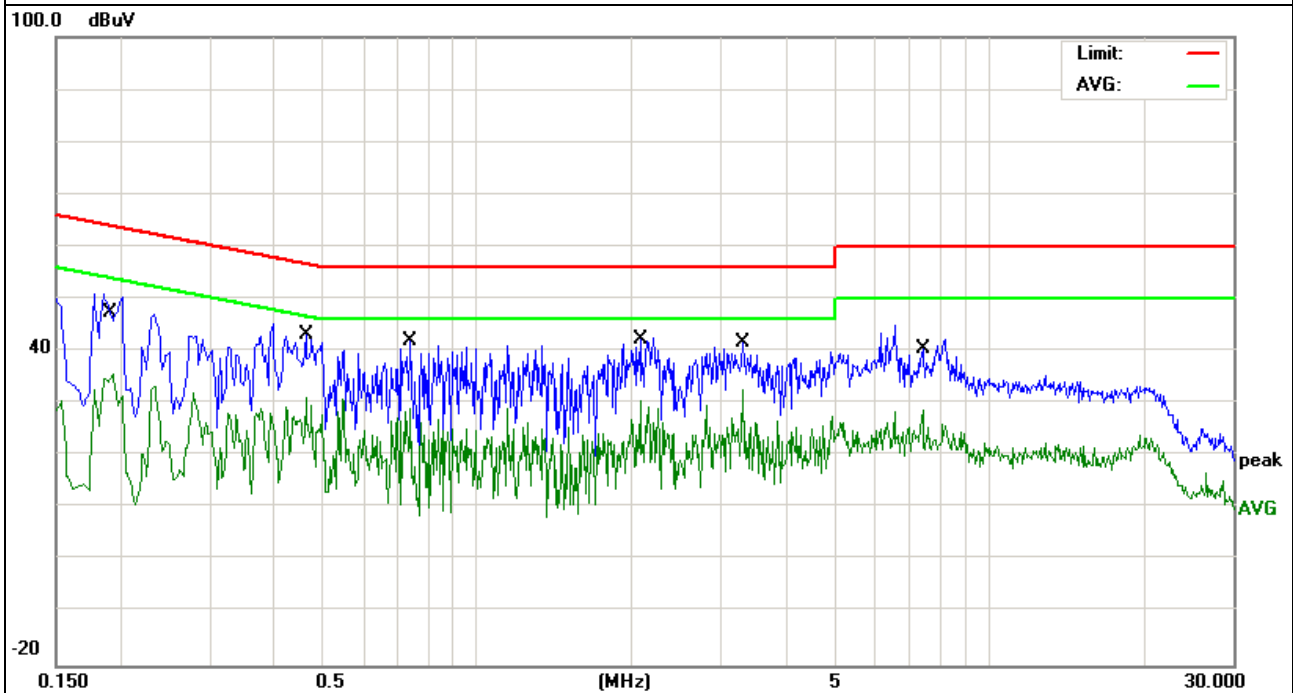

EUT :	Streaming wireless speaker	Model Name. :	HK OMNI 20
Temperature :	26 °C	Relative Humidity :	56%
Pressure :	1010hPa	Phase :	N
Test Voltage :	AC 120V/60Hz	Test Mode :	Mode 4-Ant A

Frequency (MHz)	Meter Reading (dBμV)	Factor (dB)	Emission Level (dBμV)	Limits (dBμV)	Margin (dB)	Detector Type
0.1819	40.21	11.28	51.49	64.39	-12.90	QP
0.1819	22.77	11.28	34.05	54.39	-20.34	AVG
0.2340	34.24	11.01	45.25	62.30	-17.05	QP
0.2340	19.55	11.01	30.56	52.30	-21.74	AVG
0.4260	30.13	10.66	40.79	57.33	-16.54	QP
0.4260	17.53	10.66	28.19	47.33	-19.14	AVG
0.9300	24.95	10.52	35.47	56.00	-20.53	QP
0.9300	14.02	10.52	24.54	46.00	-21.46	AVG
2.2220	25.60	10.53	36.13	56.00	-19.87	QP
2.2220	18.03	10.53	28.56	46.00	-17.44	AVG
20.1220	25.38	11.11	36.49	60.00	-23.51	QP
20.1220	12.36	11.11	23.47	50.00	-26.53	AVG

Remark:

1. All readings are Quasi-Peak and Average values.
2. Factor = Insertion Loss + Cable Loss.

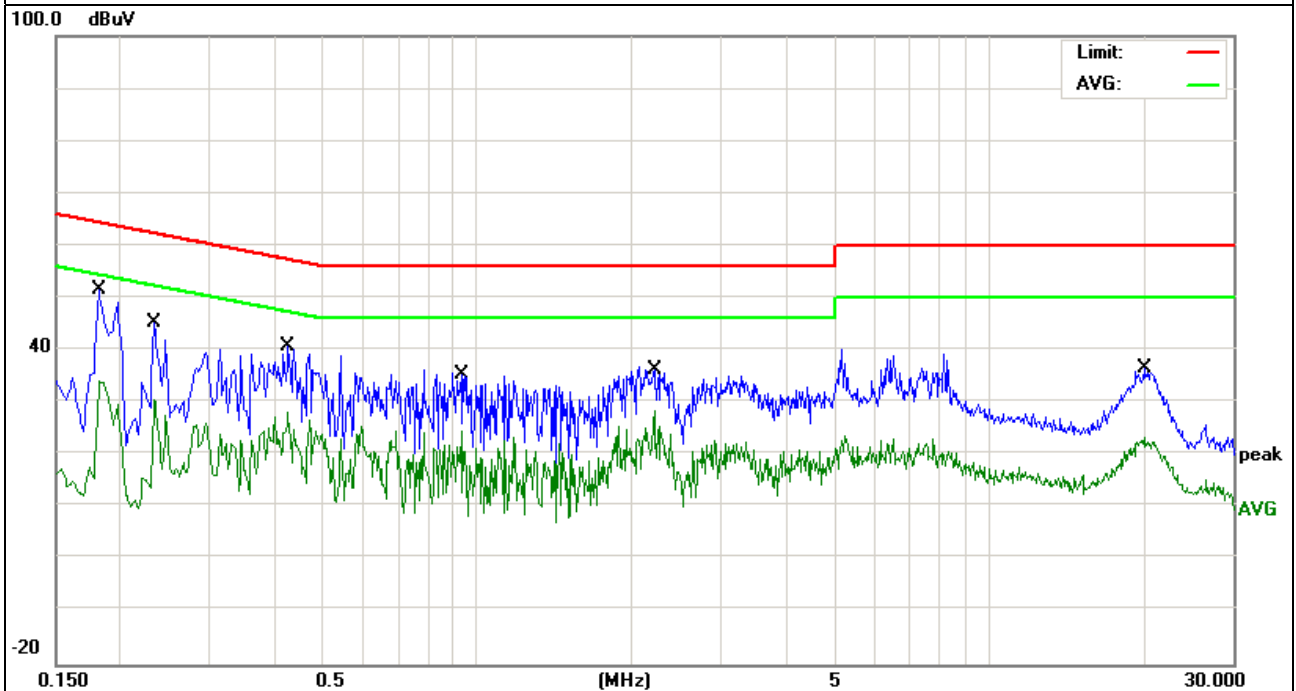

EUT :	Streaming wireless speaker	Model Name. :	HK OMNI 20
Temperature :	26 °C	Relative Humidity :	56%
Pressure :	1010hPa	Phase :	L
Test Voltage :	AC 120V/60Hz	Test Mode :	Mode 4-Ant B

Frequency (MHz)	Meter Reading (dBμV)	Factor (dB)	Emission Level (dBμV)	Limits (dBμV)	Margin (dB)	Detector Type
0.1980	49.11	9.50	58.61	63.69	-5.08	QP
0.1980	31.19	9.50	40.69	53.69	-13.00	AVG
0.2620	42.25	9.49	51.74	61.36	-9.62	QP
0.2620	25.58	9.49	35.07	51.36	-16.29	AVG
0.4580	32.93	9.51	42.44	56.73	-14.29	QP
0.4580	15.36	9.51	24.87	46.73	-21.86	AVG
3.7140	28.62	9.58	38.20	56.00	-17.80	QP
3.7140	12.15	9.58	21.73	46.00	-24.27	AVG
12.4379	32.41	9.78	42.19	60.00	-17.81	QP
12.4379	18.11	9.78	27.89	50.00	-22.11	AVG
16.4579	31.73	9.98	41.71	60.00	-18.29	QP
16.4579	17.20	9.98	27.18	50.00	-22.82	AVG

Remark:

1. All readings are Quasi-Peak and Average values.
2. Factor = Insertion Loss + Cable Loss.

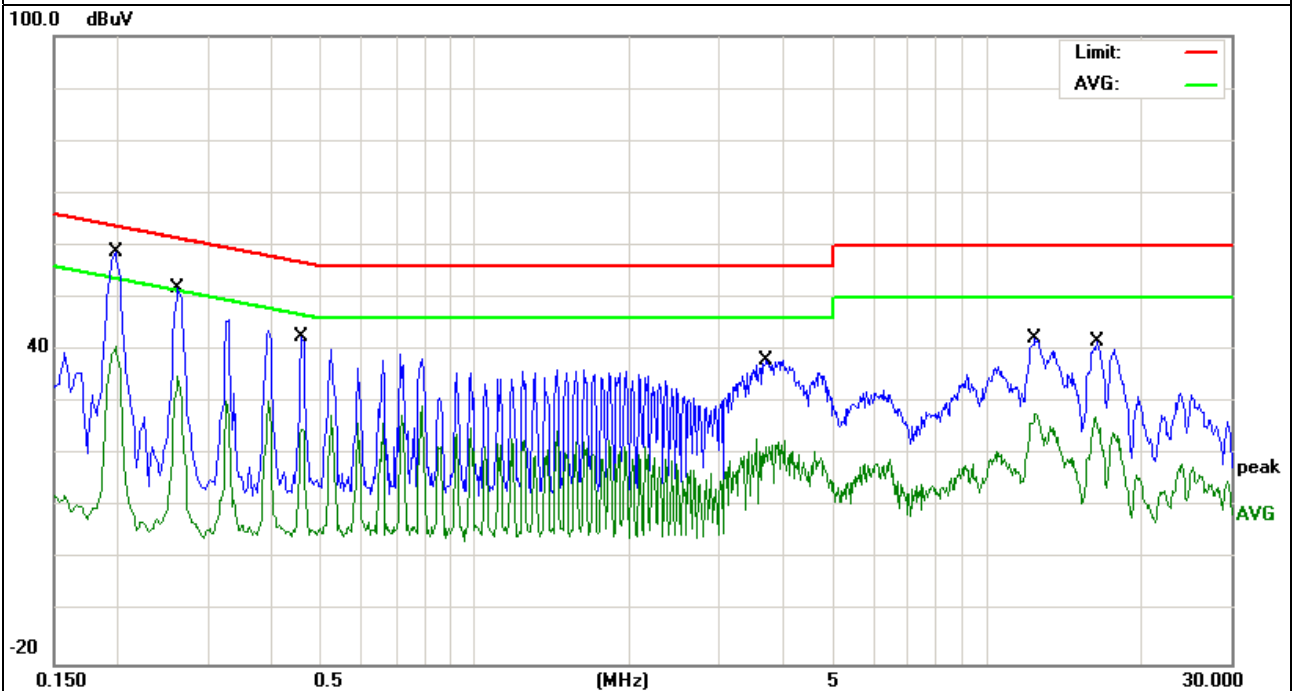

EUT :	Streaming wireless speaker	Model Name. :	HK OMNI 20
Temperature :	26 °C	Relative Humidity :	56%
Pressure :	1010hPa	Phase :	N
Test Voltage :	AC 120V/60Hz	Test Mode :	Mode 4-Ant B

Frequency (MHz)	Meter Reading (dBμV)	Factor (dB)	Emission Level (dBμV)	Limits (dBμV)	Margin (dB)	Detector Type
0.1940	47.48	9.51	56.99	63.86	-6.87	QP
0.1940	29.46	9.51	38.97	53.86	-14.89	AVG
0.2620	40.98	9.49	50.47	61.36	-10.89	QP
0.2620	23.95	9.49	33.44	51.36	-17.92	AVG
0.3940	36.36	9.50	45.86	57.98	-12.12	QP
0.3940	20.99	9.50	30.49	47.98	-17.49	AVG
0.7180	33.65	9.53	43.18	56.00	-12.82	QP
0.7180	26.55	9.53	36.08	46.00	-9.92	AVG
3.7300	35.41	9.58	44.99	56.00	-11.01	QP
3.7300	23.48	9.58	33.06	46.00	-12.94	AVG
12.3099	37.40	9.78	47.18	60.00	-12.82	QP
12.3099	25.83	9.78	35.61	50.00	-14.39	AVG

Remark:

1. All readings are Quasi-Peak and Average values.
2. Factor = Insertion Loss + Cable Loss.

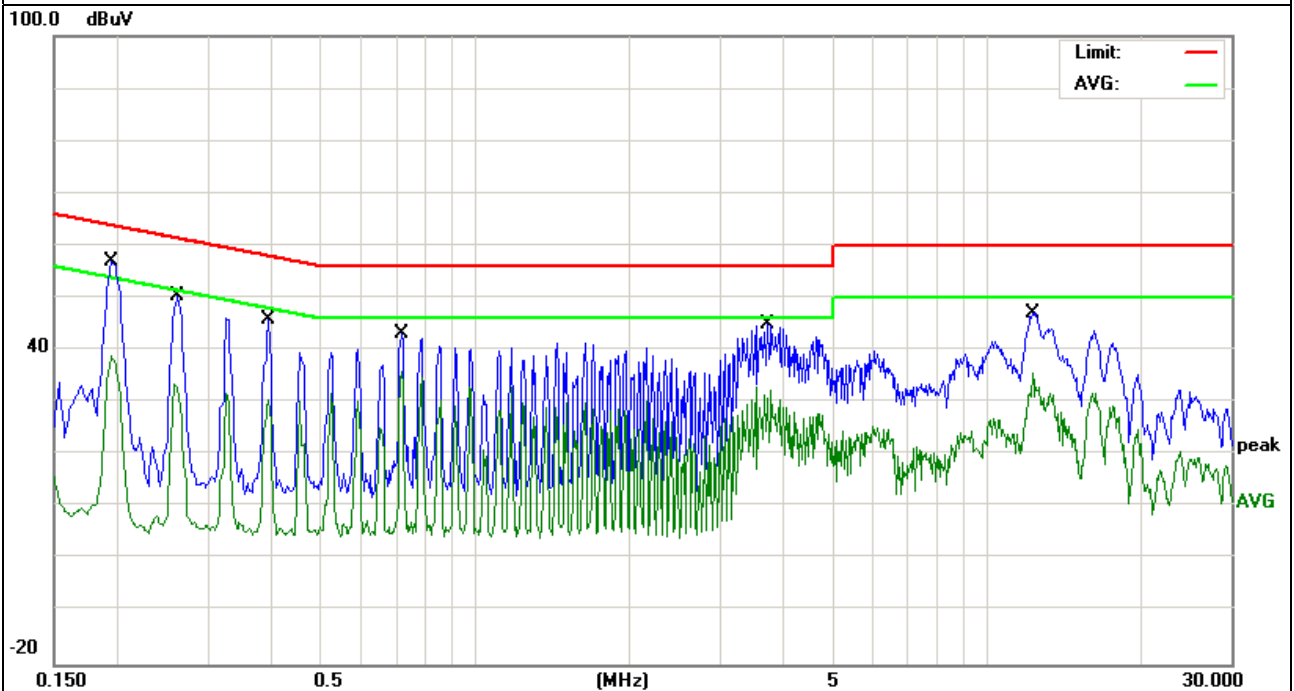

3.2 RADIATED EMISSION MEASUREMENT

3.2.1 RADIATED EMISSION LIMITS (Frequency Range 9kHz-1000MHz)

20dBc in any 100 kHz bandwidth outside the operating frequency band. In case the emission fall within the restricted band specified on 15.205(a), then the 15.209(a) limit in the table below has to be followed.

Frequencies (MHz)	Field Strength (micorvolts/meter)	Measurement Distance (meters)
0.009~0.490	2400/F(KHz)	300
0.490~1.705	24000/F(KHz)	30
1.705~30.0	30	30
30~88	100	3
88~216	150	3
216~960	200	3
Above 960	500	3

LIMITS OF RADIATED EMISSION MEASUREMENT (Above 1000MHz)

FREQUENCY (MHz)	Class A (dBuV/m) (at 3M)		Class B (dBuV/m) (at 3M)	
	PEAK	AVERAGE	PEAK	AVERAGE
Above 1000	80	60	74	54

Notes:

- (1) The limit for radiated test was performed according to FCC PART 15C.
- (2) The tighter limit applies at the band edges.
- (3) Emission level (dBuV/m)=20log Emission level (uV/m).

Spectrum Parameter	Setting
Attenuation	Auto
Start Frequency	1000 MHz
Stop Frequency	10th carrier harmonic
Receiver Parameter	Setting
Attenuation	Auto
Start ~ Stop Frequency	9kHz~150kHz / RB 200Hz for QP
Start ~ Stop Frequency	150kHz~30MHz / RB 9kHz for QP
Start ~ Stop Frequency	30MHz~1000MHz / RB 120kHz for QP
Start ~ Stop Frequency	Above 1GHz/ 1 MHz / 1 MHz for Peak, 1 MHz / 10Hz for Average

3.2.2 TEST PROCEDURE

- a. The measuring distance of at 3 m shall be used for measurements at frequency up to 1GHz. For frequencies above 1GHz, any suitable measuring distance may be used.
- b. The EUT was placed on the top of a rotating table 0.8 meters above the ground at a 3 meter open area test site. The table was rotated 360 degrees to determine the position of the highest radiation.
- c. The height of the equipment or of the substitution antenna shall be 0.8 m; the height of the test antenna shall vary between 1 m to 4 m. Both horizontal and vertical polarizations of the antenna are set to make the measurement.
- d. The initial step in collecting conducted emission data is a spectrum analyzer peak detector mode pre-scanning the measurement frequency range. Significant peaks are then marked and then Quasi Peak detector mode re-measured.
- e. If the Peak Mode measured value compliance with and lower than Quasi Peak Mode Limit, the EUT shall be deemed to meet QP Limits and then no additional QP Mode measurement performed.
- f. For the actual test configuration, please refer to the related Item –EUT Test Photos.

Note:

Both horizontal and vertical antenna polarities were tested and performed pretest to three orthogonal axis. The worst case emissions were reported

3.2.3 DEVIATION FROM TEST STANDARD

No deviation

3.2.4 TEST SETUP

(A) Radiated Emission Test-Up Frequency Below 30MHz

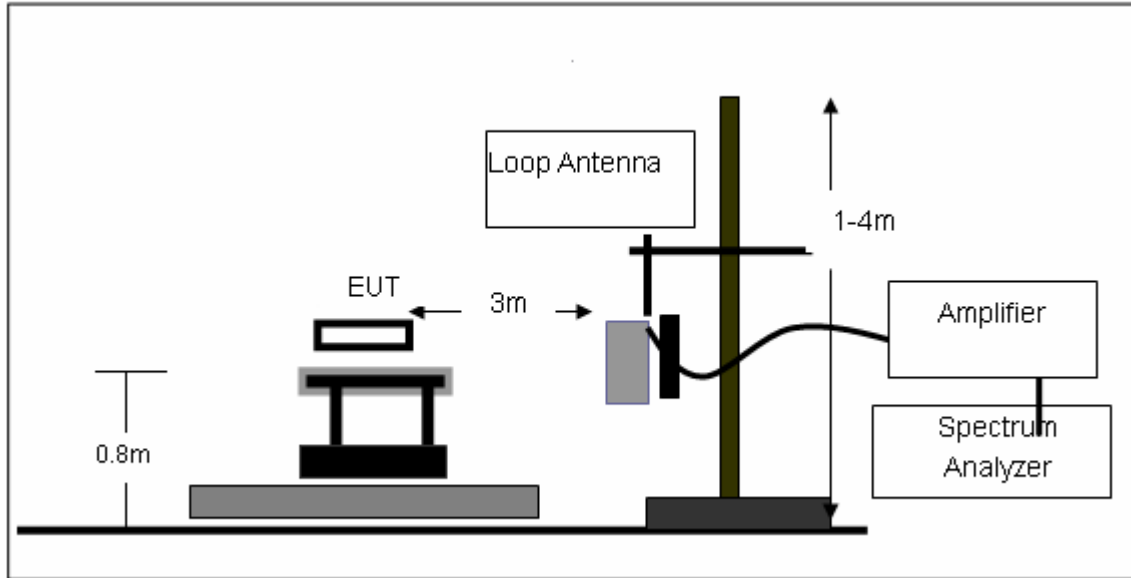

(B) Radiated Emission Test-Up Frequency 30MHz~1GHz

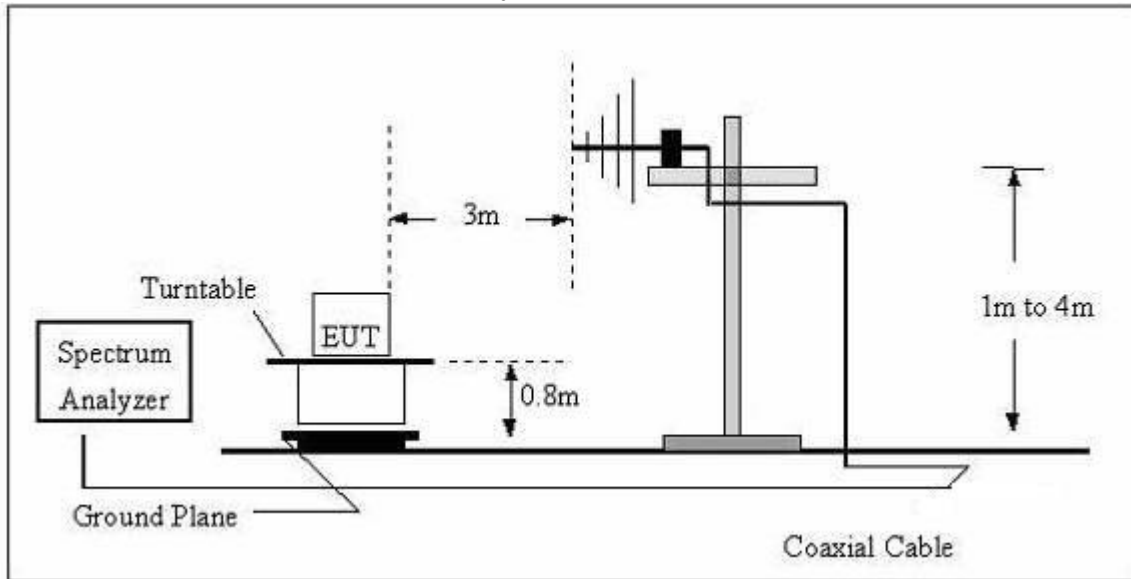

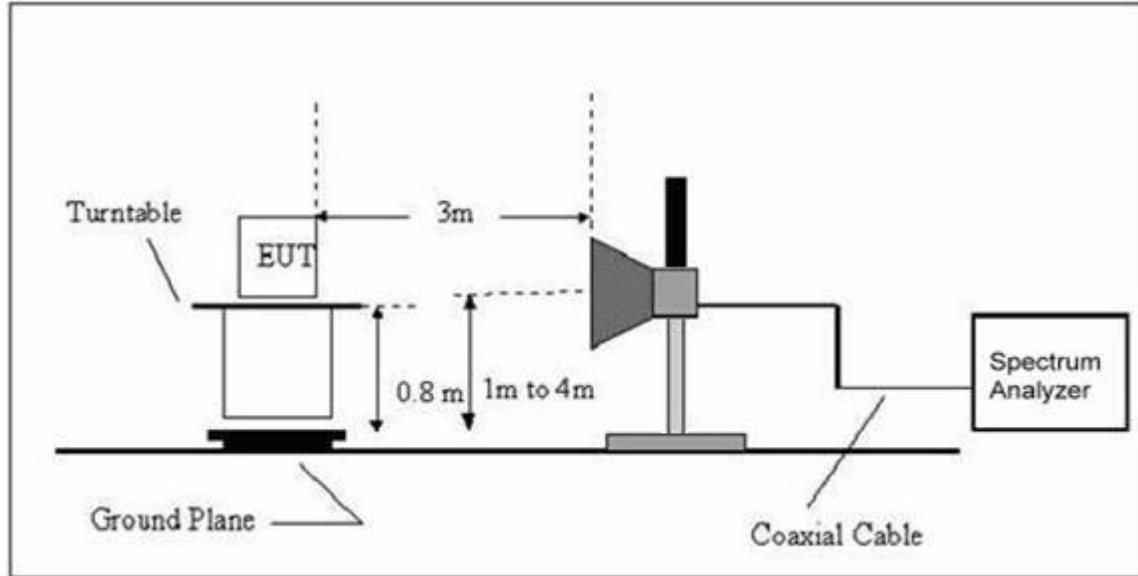
(C) Radiated Emission Test-Up Frequency Above 1GHz**3.2.5 EUT OPERATING CONDITIONS**

The EUT tested system was configured as the statements of 2.4 Unless otherwise a special operating condition is specified in the follows during the testing.

3.2.6 TEST RESULTS (BETWEEN 9KHZ – 30 MHZ)

EUT:	Streaming wireless speaker	Model Name. :	HK OMNI 20
Temperature:	20 °C	Relative Humidity:	48%
Pressure:	1010 hPa	Test Voltage :	N/A
Test Mode :	TX	Polarization :	--

Freq.	Reading	Limit	Margin	State
(MHz)	(dBuV/m)	(dBuV/m)	(dB)	P/F
--	--	--	--	N/A
--	--	--	--	N/A

NOTE:

The amplitude of spurious emissions which are attenuated by more than 20dB below the permissible value has no need to be reported.

Distance extrapolation factor = $40 \log(\text{specific distance}/\text{test distance})$ (dB);

Limit line = specific limits(dBuv) + distance extrapolation factor.

3.2.7 TEST RESULTS (BETWEEN 30MHZ – 1GHZ)

EUT :	Streaming wireless speaker	Model Name :	HK OMNI 20
Temperature :	20 °C	Relative Humidity :	48%
Pressure:	1010 hPa	Test Voltage :	AC 120V/60Hz
Test Mode :	TX-Ant A		

Frequency (MHz)	Meter Reading (dBµV)	Factor (dB)	Emission Level (dBµV/m)	Limits (dBµV/m)	Margin (dB)	Detect or Type	Comment
Low Channel (2412 MHz)-Below 1G-802.11b							
133.1657	17.44	12.25	29.69	43.5	-13.81	QP	Vertical
240.0386	15.81	11.65	27.46	46	-18.54	QP	Vertical
405.2265	17.65	18.54	36.19	46	-9.81	QP	Vertical
496.0438	16.18	20.59	36.77	46	-9.23	QP	Vertical
523.2467	17.55	21.12	38.67	46	-7.33	QP	Vertical
814.8635	8.33	26.46	34.79	46	-11.21	QP	Vertical
123.2986	17.53	12.21	29.74	43.5	-13.76	QP	Horizontal
166.0431	16.94	10.81	27.75	43.5	-15.75	QP	Horizontal
288.1355	17.66	14.3	31.96	46	-14.04	QP	Horizontal
530.0123	16.01	21.12	37.13	46	-8.87	QP	Horizontal
721.7259	10.96	25.59	36.55	46	-9.45	QP	Horizontal
813.7663	11.15	26.46	37.61	46	-8.39	QP	Horizontal
Middel Channel (2437 MHz)-Below 1G-802.11b							
134.0214	17.23	12.25	29.48	43.5	-14.02	QP	Vertical
224.1543	16.15	10.73	26.88	46	-19.12	QP	Vertical
262.0546	16.76	14.62	31.38	46	-14.62	QP	Vertical
313.0644	17.88	15.26	33.14	46	-12.86	QP	Vertical
527.1698	16.32	21.12	37.44	46	-8.56	QP	Vertical
814.0721	11.58	26.46	38.04	46	-7.96	QP	Vertical
124.0756	16.65	12.21	28.86	43.5	-14.64	QP	Horizontal
264.1733	16.32	14.62	30.94	46	-15.06	QP	Horizontal
432.0856	16.93	18.82	35.75	46	-10.25	QP	Horizontal
527.4322	16.32	21.12	37.44	46	-8.56	QP	Horizontal
732.0567	9.46	25.59	35.05	46	-10.95	QP	Horizontal
814.0725	11.43	26.46	37.89	46	-8.11	QP	Horizontal

Frequency (MHz)	Meter Reading (dBµV)	Factor (dB)	Emission Level (dBµV/m)	Limits (dBµV/m)	Margin (dB)	Detect or Type	Comment
High Channel (2462 MHz)-Below 1G-802.11b							
97.8322	15.32	10.51	25.83	43.5	-17.67	QP	Vertical
142.0565	15.17	12.06	27.23	43.5	-16.27	QP	Vertical
335.1239	16.65	16.03	32.68	46	-13.32	QP	Vertical
383.9318	13.13	17.38	30.51	46	-15.49	QP	Vertical
528.2458	14.56	21.12	35.68	46	-10.32	QP	Vertical
815.9678	9.22	26.46	35.68	46	-10.32	QP	Vertical
131.7572	16.07	12.22	28.29	43.5	-15.21	QP	Horizontal
197.8925	17.44	8.99	26.43	43.5	-17.07	QP	Horizontal
288.1235	13.97	14.3	28.27	46	-17.73	QP	Horizontal
463.0543	14.58	19.5	34.08	46	-11.92	QP	Horizontal
624.1653	11.22	23.6	34.82	46	-11.18	QP	Horizontal
721.7254	13.01	25.59	38.6	46	-7.4	QP	Horizontal

EUT :	Streaming wireless speaker	Model Name :	HK OMNI 20
Temperature :	20 °C	Relative Humidity :	48%
Pressure:	1010 hPa	Test Voltage :	AC 120V/60Hz
Test Mode :	TX-Ant B		

Polar (H/V)	Frequency	Meter Reading	Factor	Emission Level	Limits	Margin	Detector Type
	(MHz)	(dBuV)	(dB)	(dBuV/m)	(dBuV/m)	(dB)	
V	35.6240	16.13	15.56	31.69	40.00	-8.31	QP
V	59.8588	18.32	5.32	23.64	40.00	-16.36	QP
V	119.8555	15.21	12.09	27.30	43.50	-16.20	QP
V	197.8926	18.03	8.99	27.02	43.50	-16.48	QP
V	253.8367	11.87	14.09	25.96	46.00	-20.04	QP
V	948.7609	8.13	29.75	37.88	46.00	-8.12	QP
H	116.9495	11.94	12.01	23.95	43.50	-19.55	QP
H	195.8220	17.23	8.97	26.20	43.50	-17.30	QP
H	255.6229	14.19	14.35	28.54	46.00	-17.46	QP
H	340.7817	13.34	16.16	29.50	46.00	-16.50	QP
H	549.0193	6.94	23.59	30.53	46.00	-15.47	QP
H	958.7943	7.08	29.85	36.93	46.00	-9.07	QP

Remark:

Absolute Level= ReadingLevel+ Factor, Margin= Absolute Level - Limit

3.2.8 TEST RESULTS (ABOVE 1000 MHZ)

EUT :	Streaming wireless speaker	Model Name :	HK OMNI 20
Temperature :	20 °C	Relative Humidity :	48%
Pressure:	1010 hPa	Test Voltage :	AC 120V/60Hz
Test Mode :	TX-Ant A		

Frequency (MHz)	Meter Reading (dBµV)	Factor (dB)	Corrected Amplitude (dBµV/m)	Limit (dBµV/m)	Margin (dB)	Detector (PK/QP/AV)	Polar (H/V)
Low Channel (2412 MHz)-Above 1G							
1464.692	68.75	-17.01	51.74	74.00	-22.26	Pk	Vertical
2004.115	66.32	-13.21	53.11	74.00	-20.89	Pk	Vertical
4824.125	54.16	-3.60	50.56	74.00	-23.44	pk	Vertical
1336.782	65.83	-17.51	48.32	74.00	-25.68	pk	Horizontal
1651.514	68.15	-15.93	52.22	74.00	-21.78	pk	Horizontal
1993.371	64.15	-13.42	50.73	74.00	-23.27	pk	Horizontal
4824.250	57.16	-3.60	53.56	74.00	-20.44	Pk	Horizontal
Mid Channel (2437 MHz)-Above 1G							
1329.612	66.21	-17.59	48.62	74.00	-25.38	Pk	Vertical
1503.798	64.64	-17.15	47.49	74.00	-26.51	pk	Vertical
1643.112	63.22	-15.86	47.36	74.00	-26.64	pk	Vertical
1989.126	61.01	-13.36	47.65	74.00	-26.35	pk	Vertical
4874.103	56.79	-3.60	53.19	74.00	-20.81	pk	Vertical
1107.528	69.33	-19.4	49.93	74.00	-24.07	Pk	Horizontal
1334.389	63.42	-17.53	45.89	74.00	-28.11	pk	Horizontal
1662.398	60.11	-15.86	44.25	74.00	-29.75	Pk	Horizontal
1991.312	64.83	-13.42	51.41	74.00	-22.59	Pk	Horizontal
4874.103	54.79	-3.60	51.19	74.00	-22.81	Pk	Horizontal
High Channel (2462 MHz)- Above 1G							
1328.003	68.14	-17.59	50.55	74.00	-23.45	pk	Vertical
1664.735	67.43	-15.86	51.57	74.00	-22.43	pk	Vertical
1829.356	60.42	-14.78	45.64	74.00	-28.36	pk	Vertical
1993.476	59.33	-13.42	45.91	74.00	-28.09	pk	Vertical
4924.327	49.53	-3.60	45.93	74.00	-28.07	pk	Vertical
1329.615	67.18	-17.59	49.59	74.00	-24.41	pk	Horizontal
1663.175	58.98	-15.86	43.12	74.00	-30.88	pk	Horizontal
1992.045	61.15	-13.42	47.73	74.00	-26.27	pk	Horizontal
2806.332	62.44	-11.69	50.75	74.00	-23.25	pk	Horizontal
4924.327	51.13	-3.60	47.53	74.00	-26.47	pk	Horizontal

Note: Scan with 802.11b, 802.11g,802.11n(20M/40M), the worst case is 802.11b.
 When PK value is lower than the Average value limit, average didn't record.

EUT :	Streaming wireless speaker	Model Name :	HK OMNI 20
Temperature :	20 °C	Relative Humidity :	48%
Pressure:	1010 hPa	Test Voltage :	AC 120V/60Hz
Test Mode :	TX-Ant B		

Frequency (MHz)	Meter Reading (dBμV)	Factor (dB)	Corrected Amplitude (dBμV/m)	Limit (dBμV/m)	Margin (dB)	Detector (PK/QP/AV)	Polar (H/V)
Low Channel (2412 MHz)-Above 1G							
4824	47.14	10.44	57.58	74	-16.42	Pk	Vertical
4824	30.03	10.44	40.47	54	-13.53	Av	Vertical
7236	42.47	12.39	54.86	74	-19.14	Pk	Vertical
7236	26.26	12.39	38.65	54	-15.35	Av	Vertical
4824	46.09	10.44	56.53	74	-17.47	Pk	Horizontal
4824	30.28	10.44	40.72	54	-13.28	Av	Horizontal
7236	42.07	12.39	54.46	74	-19.54	Pk	Horizontal
7236	26.92	12.39	39.31	54	-14.69	Av	Horizontal
Mid Channel (2437 MHz)-Above 1G							
4874	46.16	10.4	56.56	74	-17.44	Pk	Vertical
4874	29.72	10.4	40.12	54	-13.88	Av	Vertical
7311	42.12	12.75	54.87	74	-19.13	Pk	Vertical
7311	25.55	12.75	38.3	54	-15.7	Av	Vertical
4874	46.06	10.4	56.46	74	-17.54	Pk	Horizontal
4874	30.98	10.4	41.38	54	-12.62	Av	Horizontal
7311	41.42	12.75	54.17	74	-19.83	Pk	Horizontal
7311	26.78	12.75	39.53	54	-14.47	Av	Horizontal
High Channel (2462 MHz)- Above 1G							
4924	45.72	10.39	56.11	74	-17.89	Pk	Vertical
4924	30.2	10.39	40.59	54	-13.41	Av	Vertical
7386	41.56	12.68	54.24	74	-19.76	Pk	Vertical
7386	25.9	12.68	38.58	54	-15.42	Av	Vertical
4924	45.96	10.39	56.35	74	-17.65	Pk	Horizontal
4924	30.83	10.39	41.22	54	-12.78	Av	Horizontal
7386	41.79	12.68	54.47	74	-19.53	Pk	Horizontal
7386	26.94	12.68	39.62	54	-14.38	Av	Horizontal

Note: Scan with 802.11b, 802.11g,802.11n(20M/40M), the worst case is 802.11b.

Conducted Spurious Emissions at Antenna Port: Ant A
802.11b Low Channel

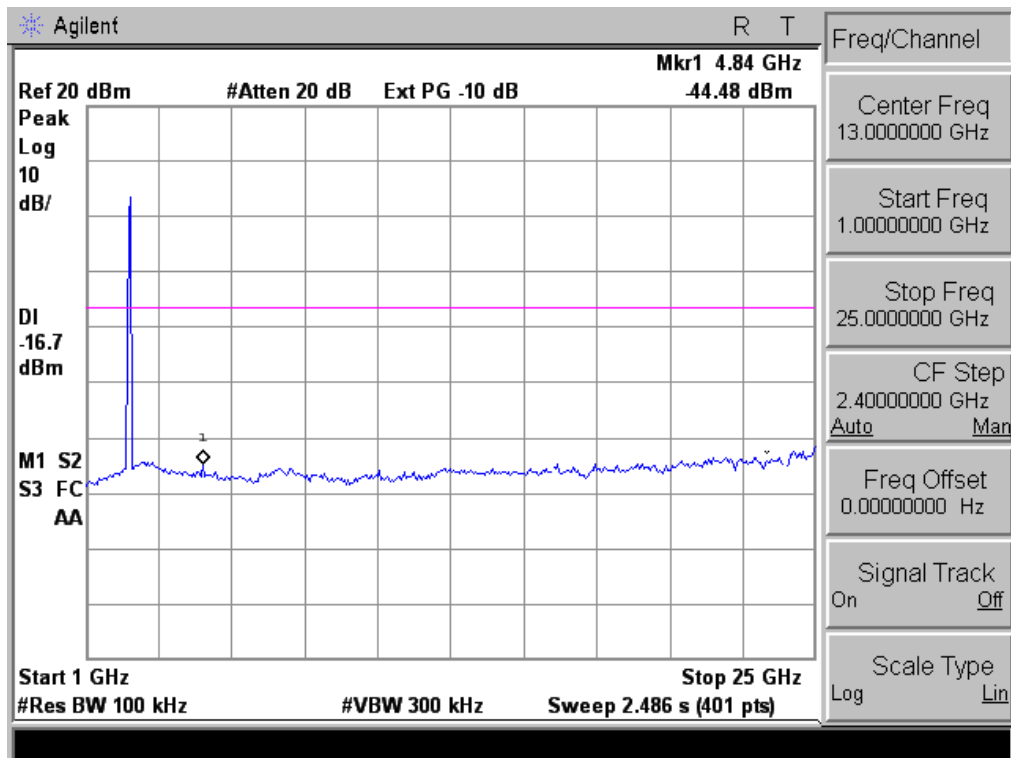
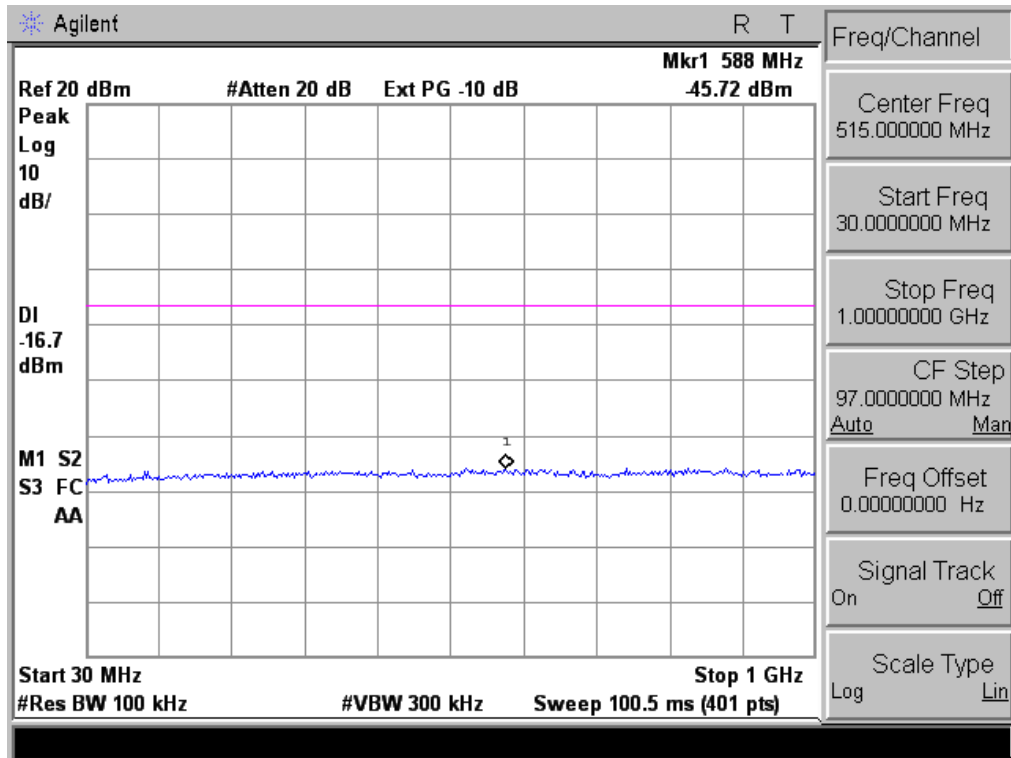

802.11b Middle Channel

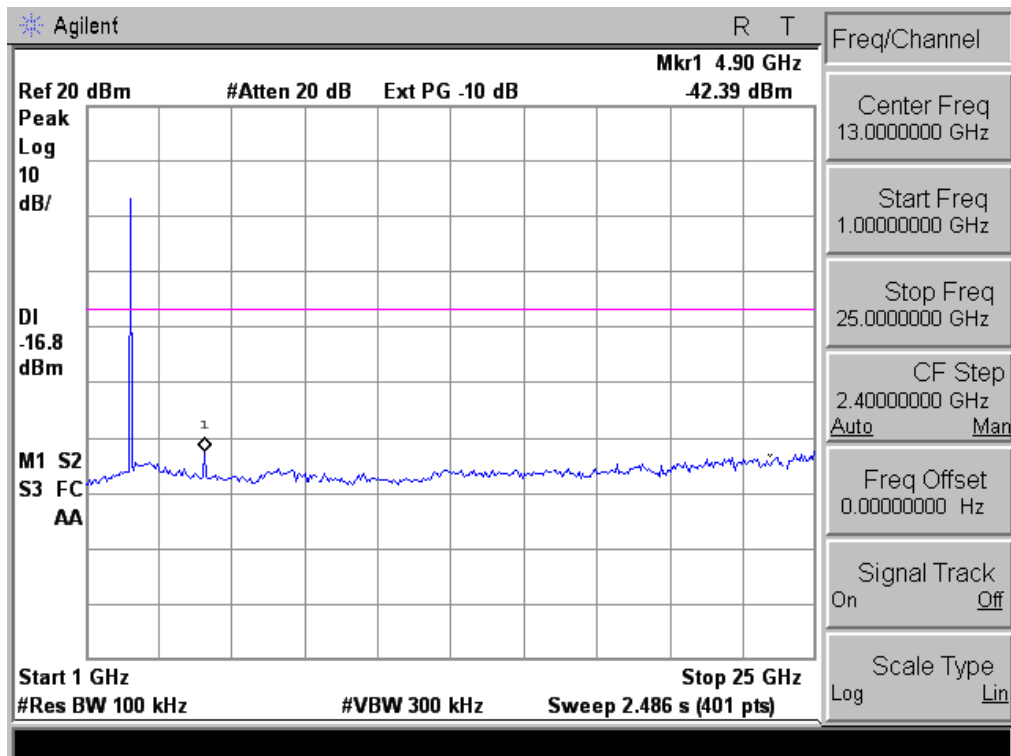
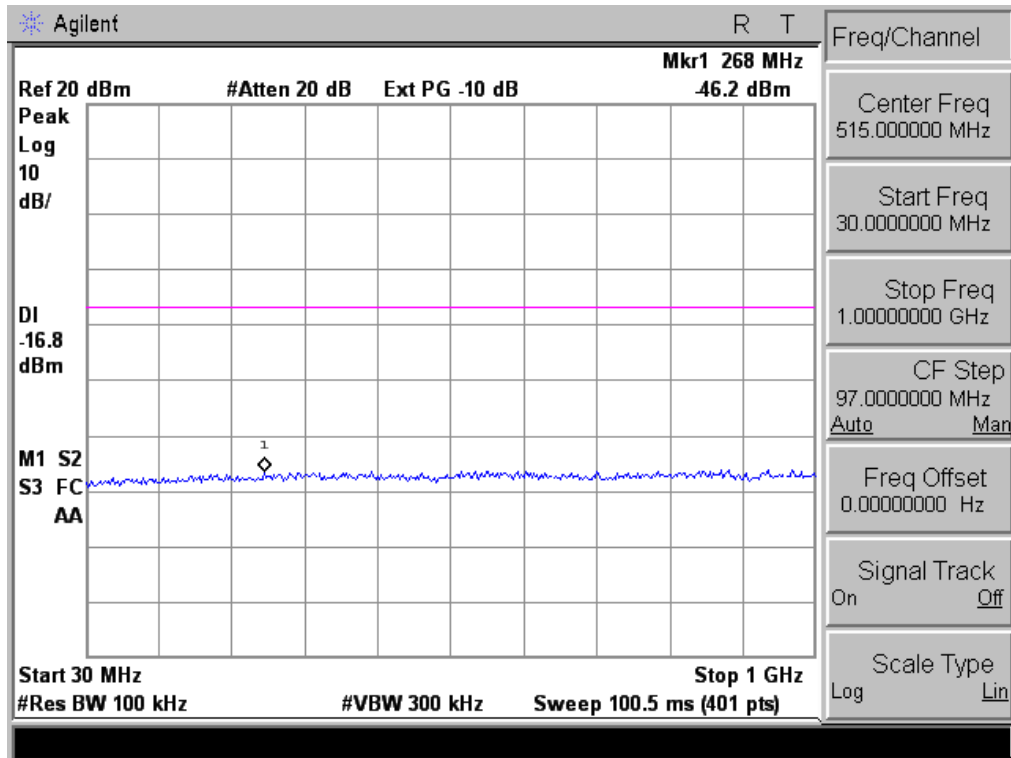

802.11b High Channel

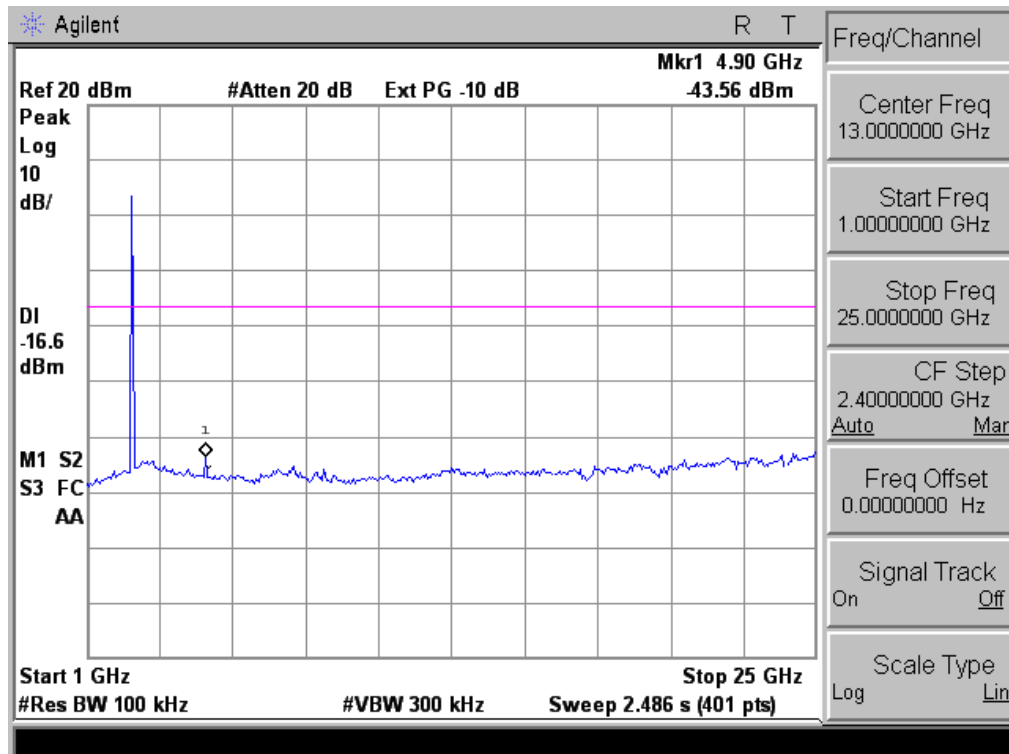
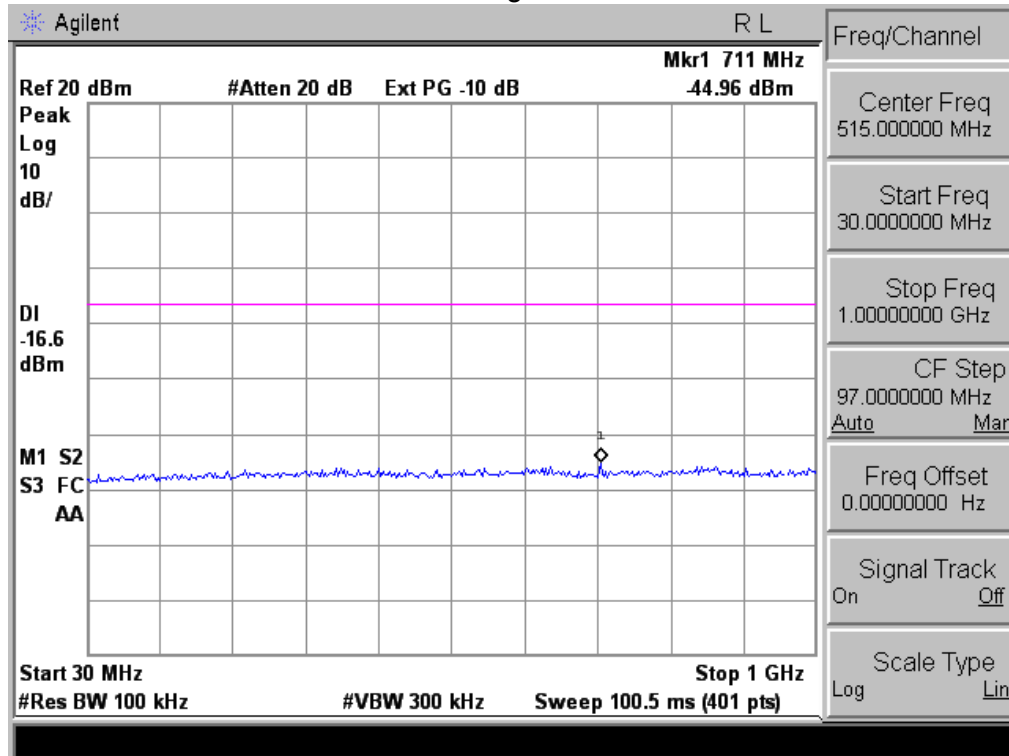

802.11g Low Channel

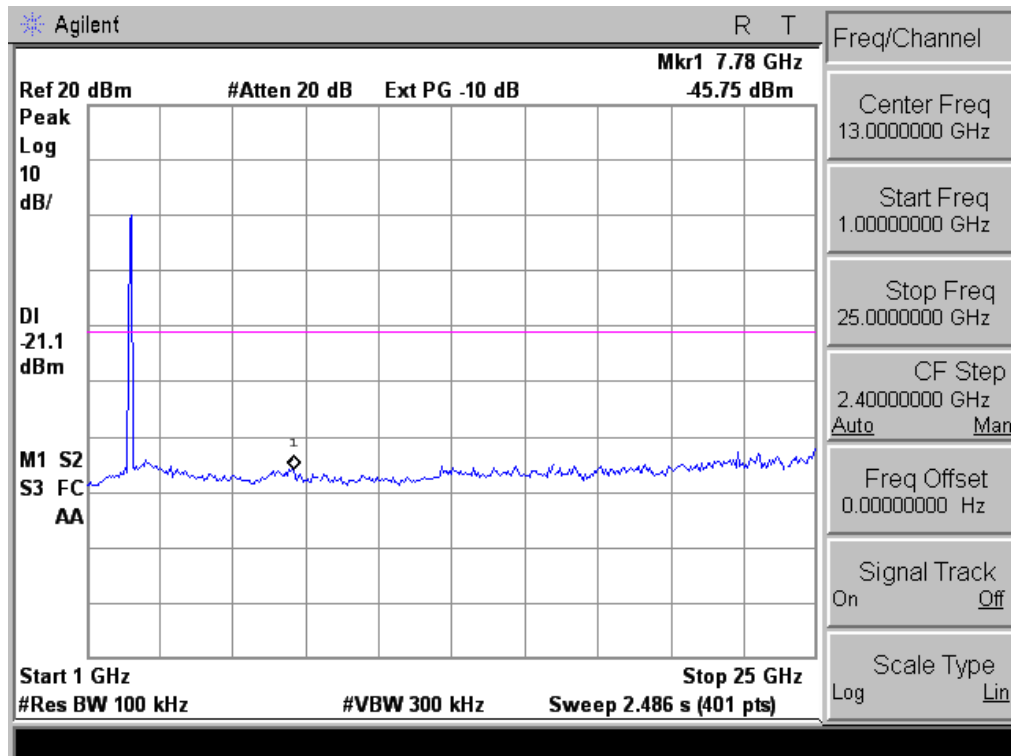
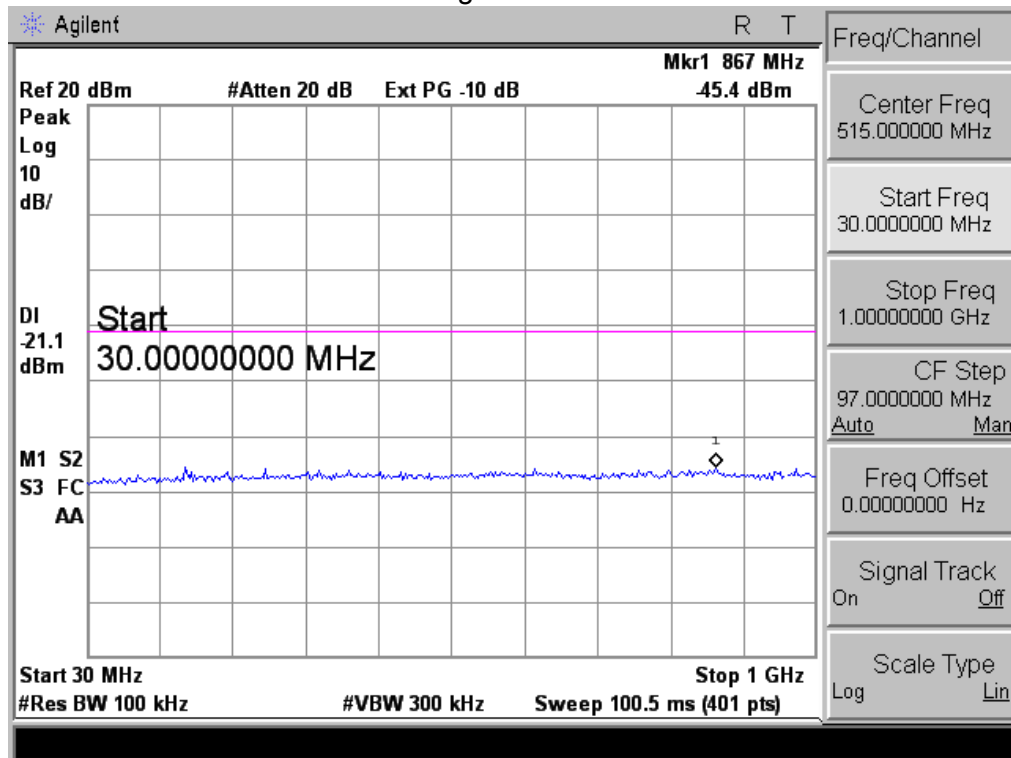

802.11g Middle Channel

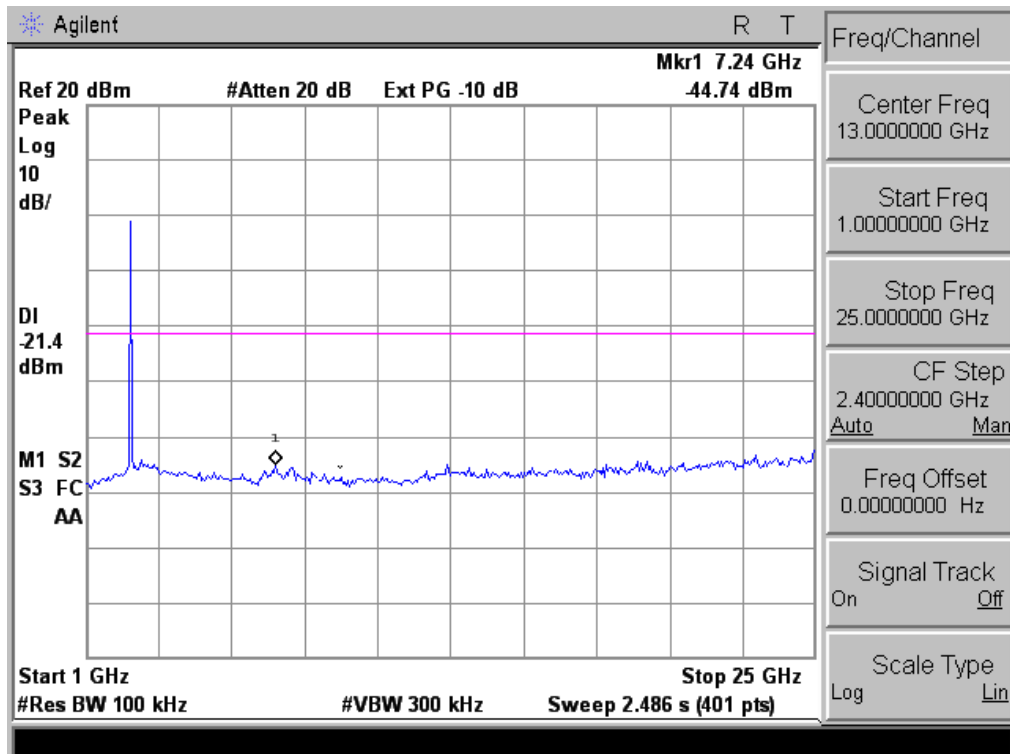
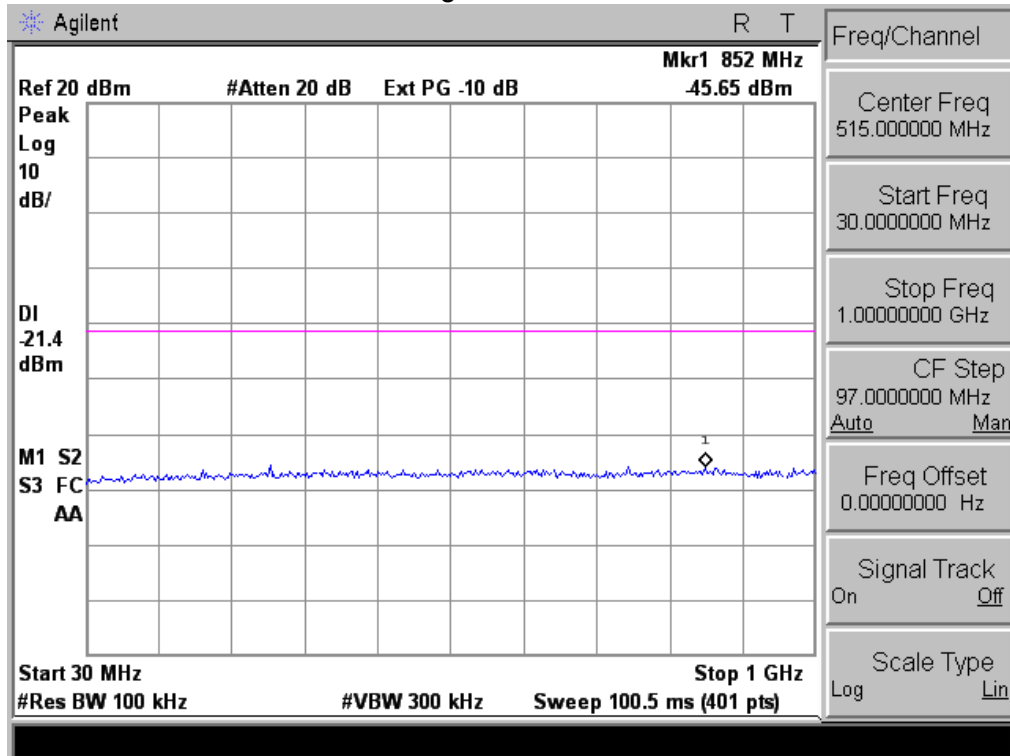

802.11g High Channel

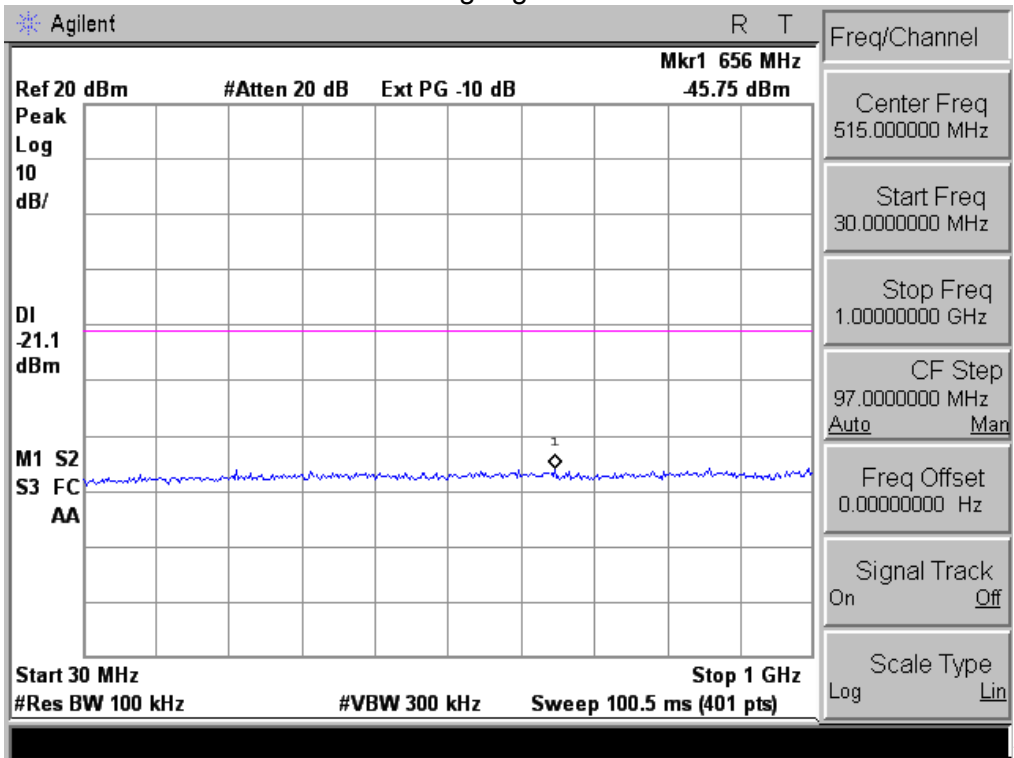

2

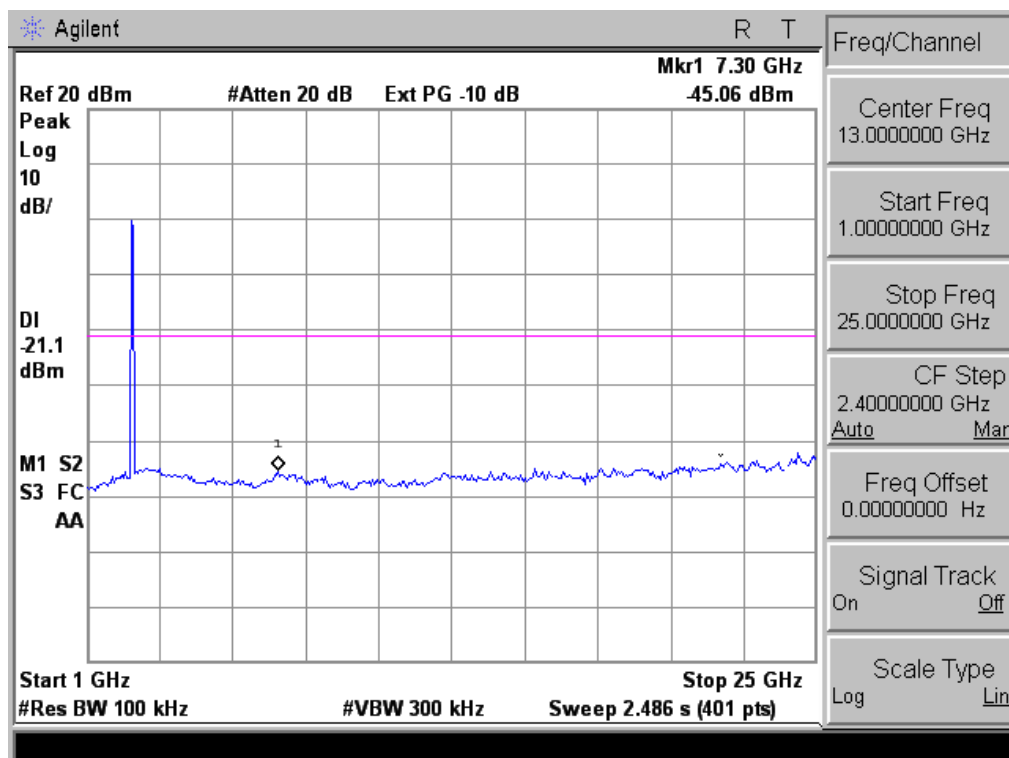

802.11n-HT20 Low Channel

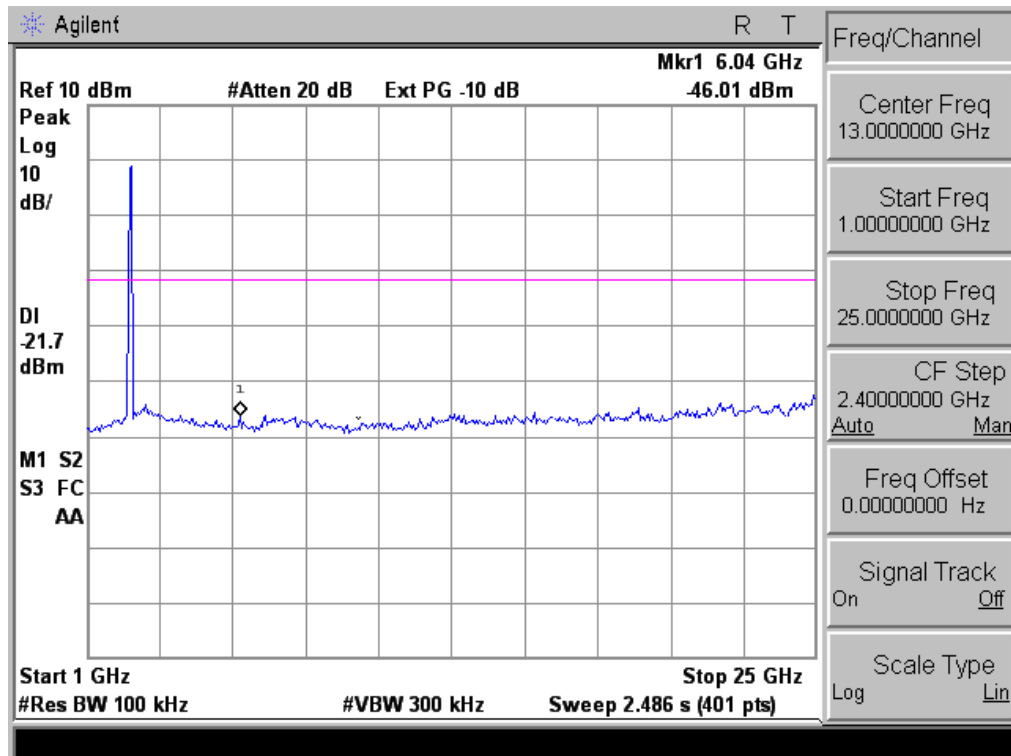
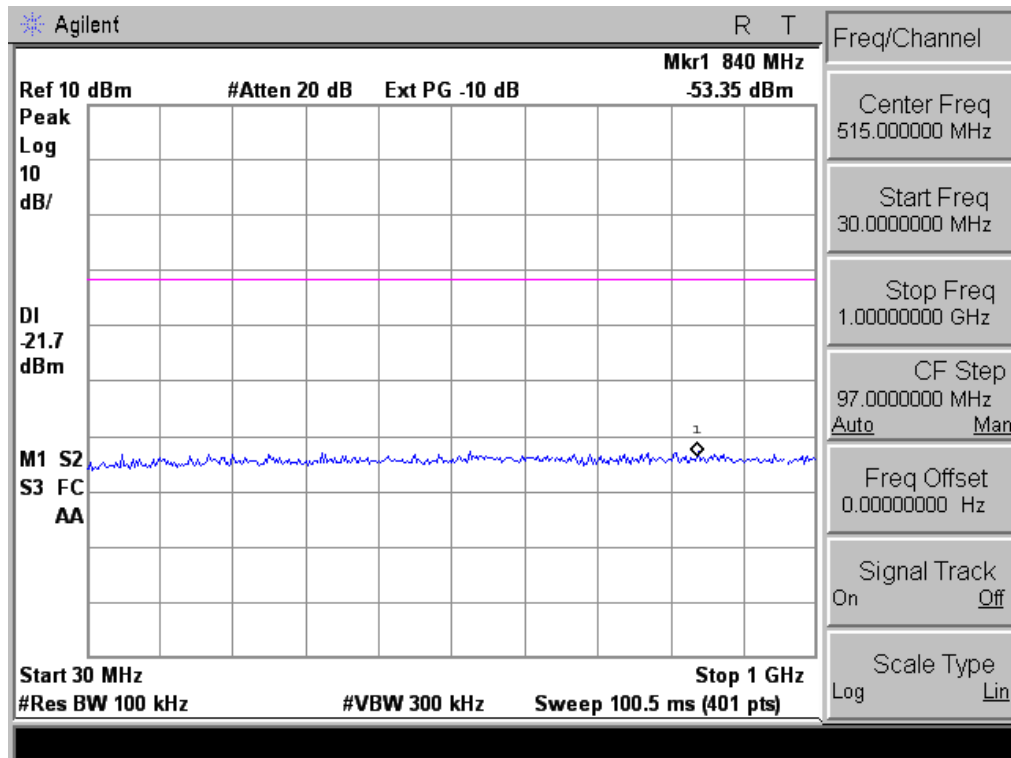

802.11n-HT20 Middle Channel

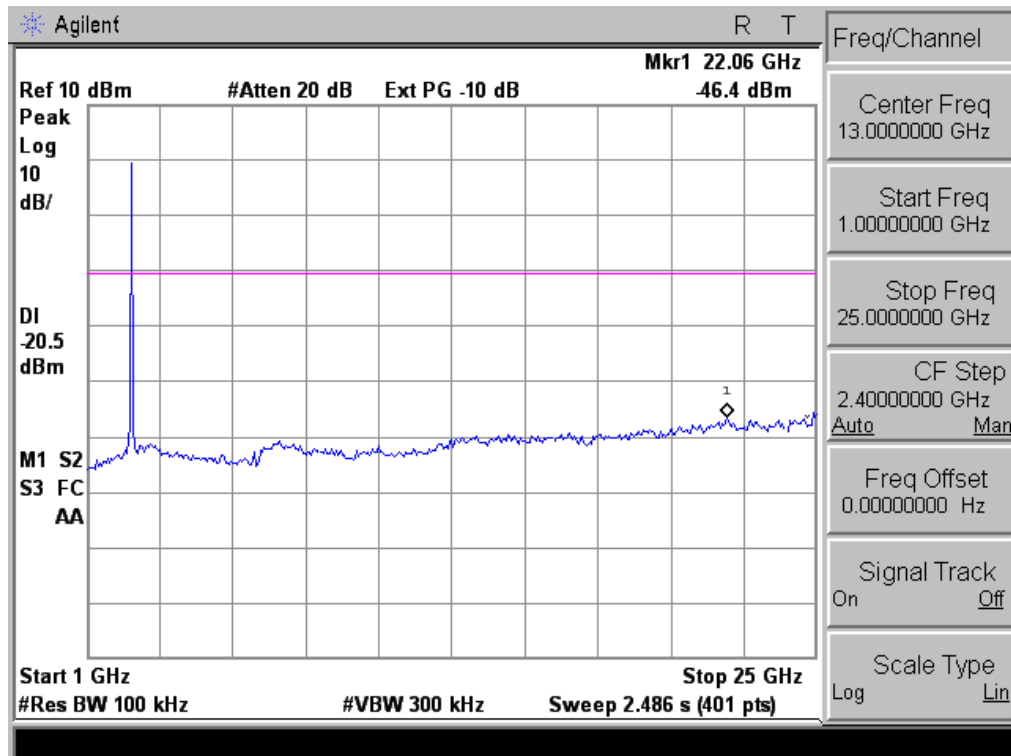
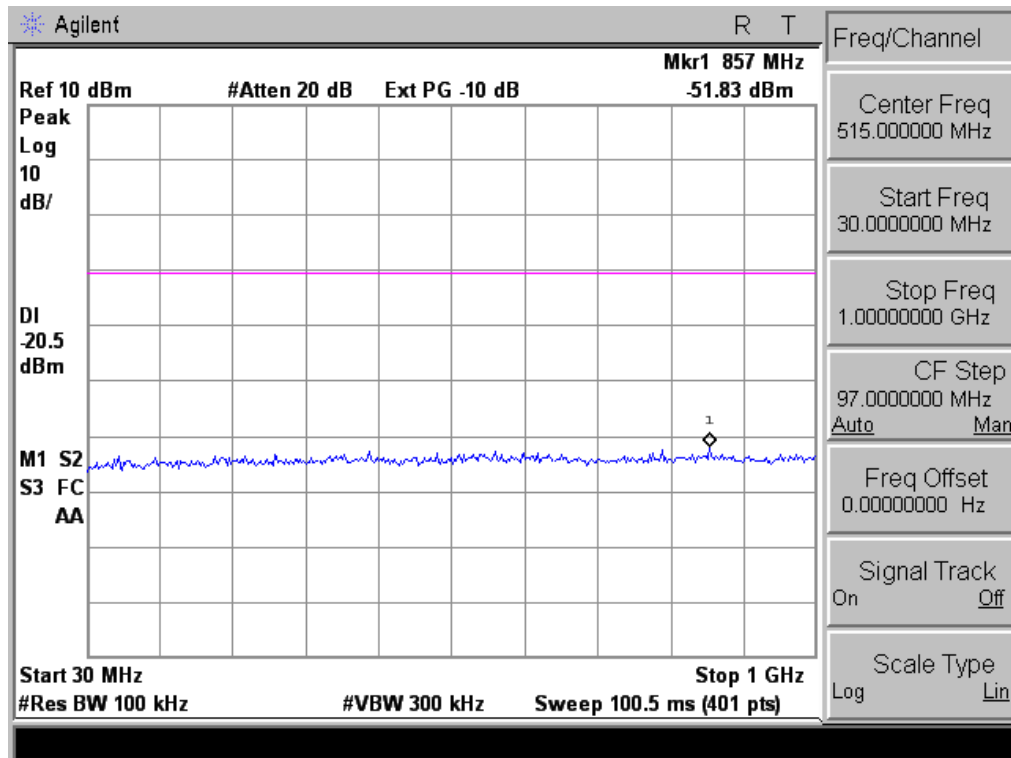

802.11n-HT20 High Channel

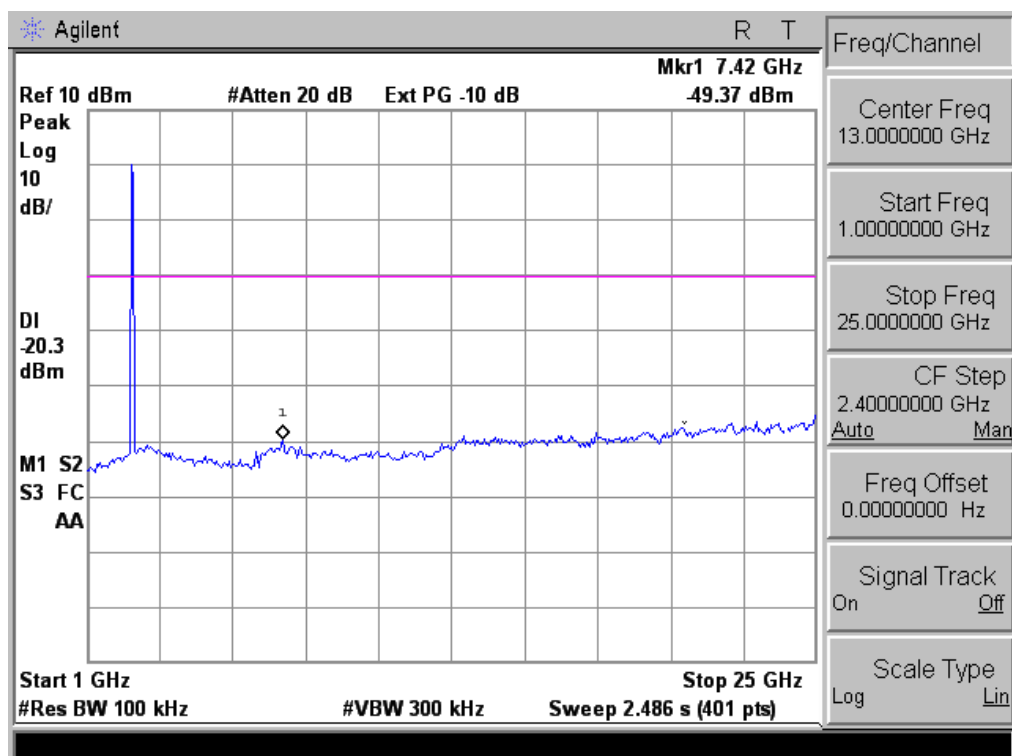
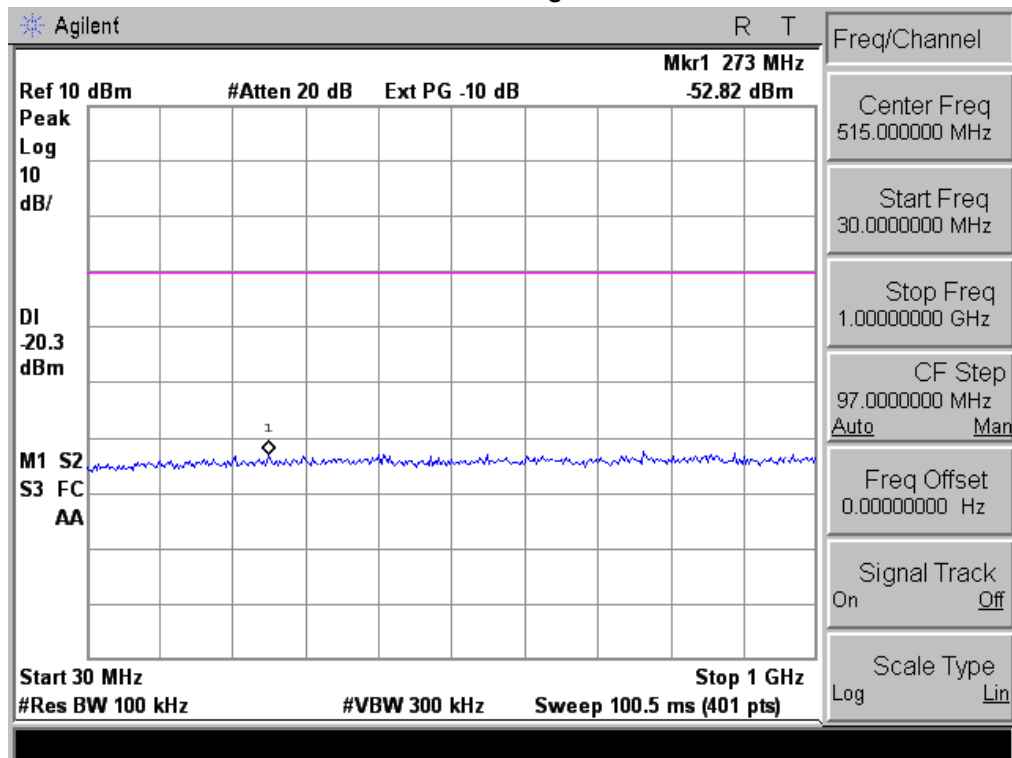

Conducted Spurious Emissions at Antenna Port: Ant B
802.11b Low Channel

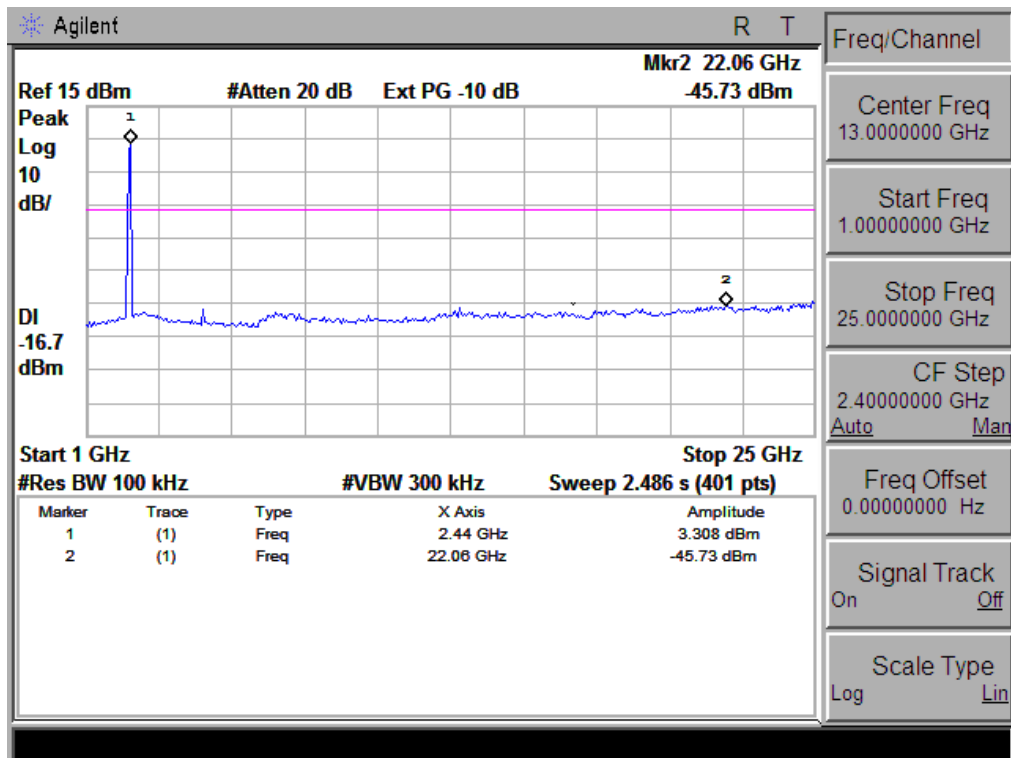
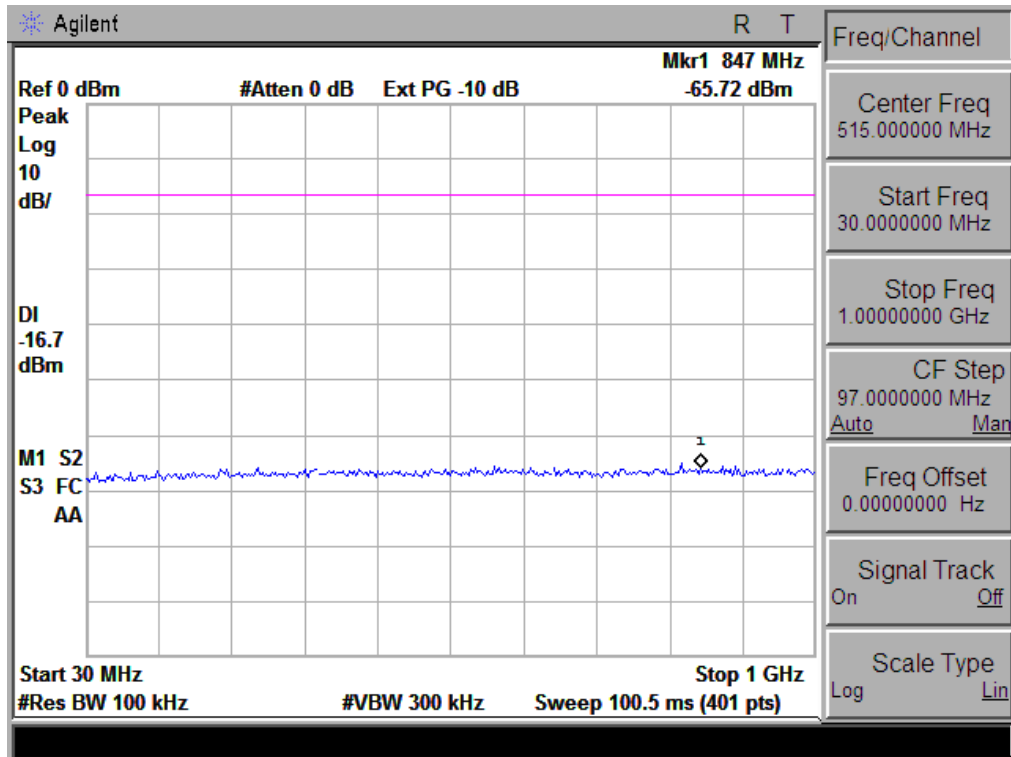

802.11b Middle Channel

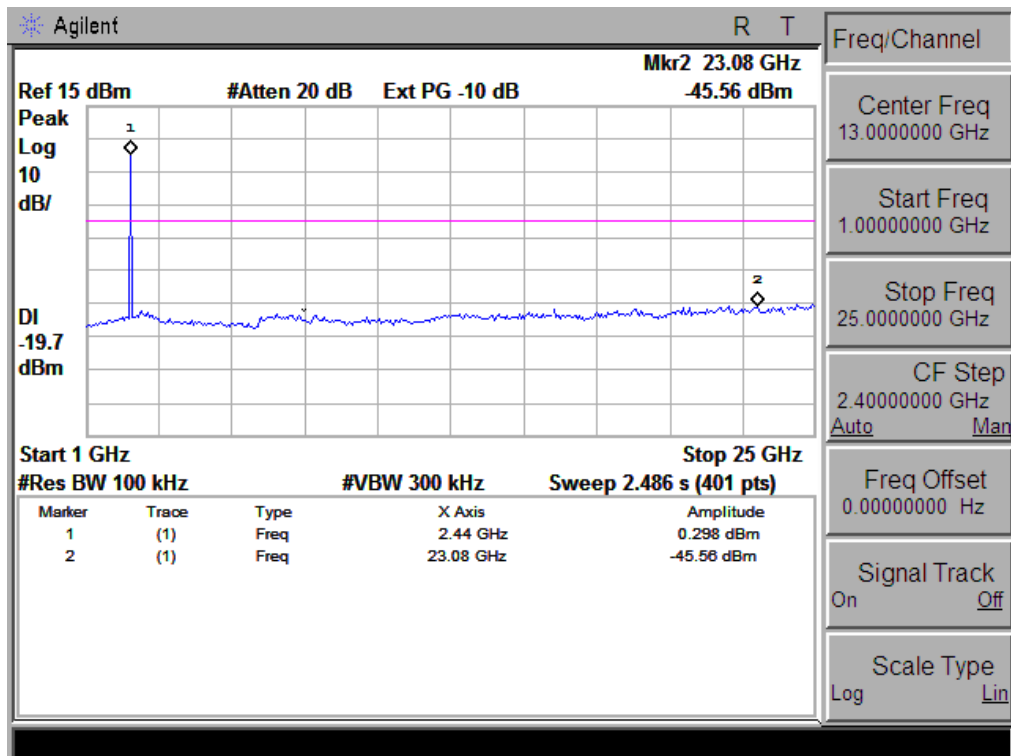
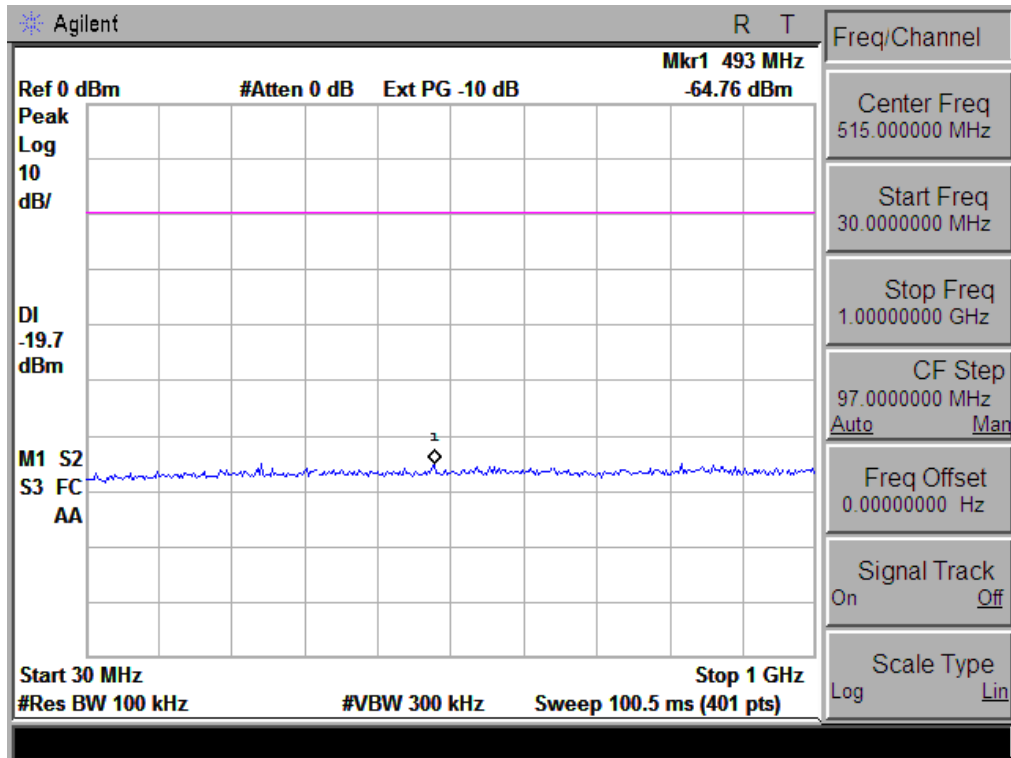

802.11b High Channel

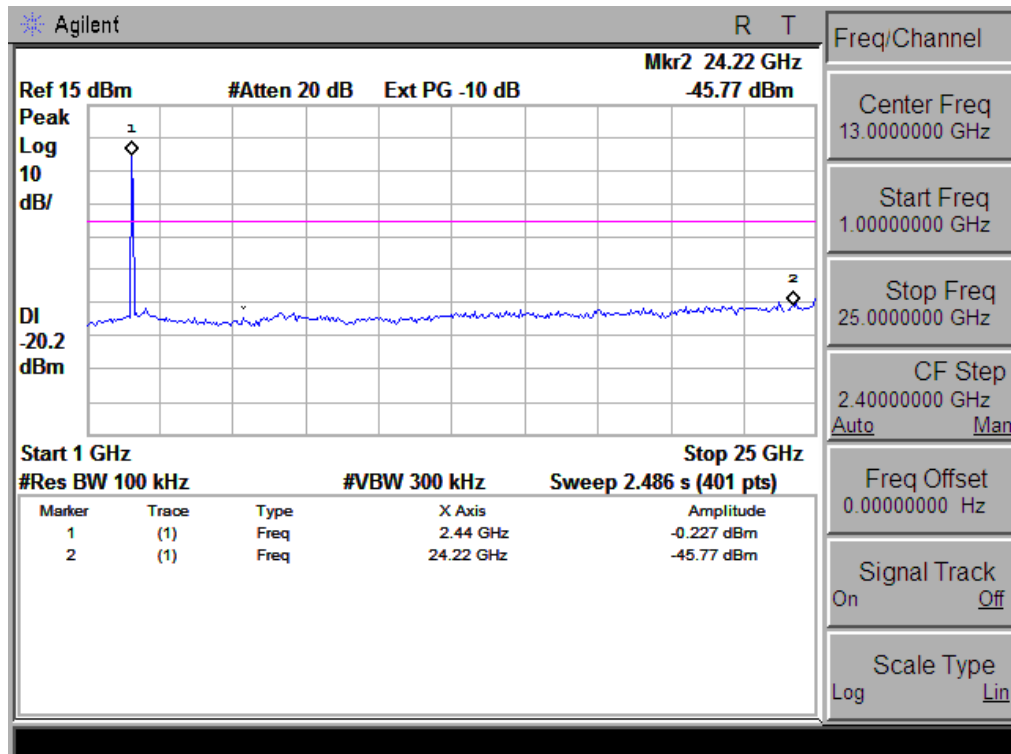
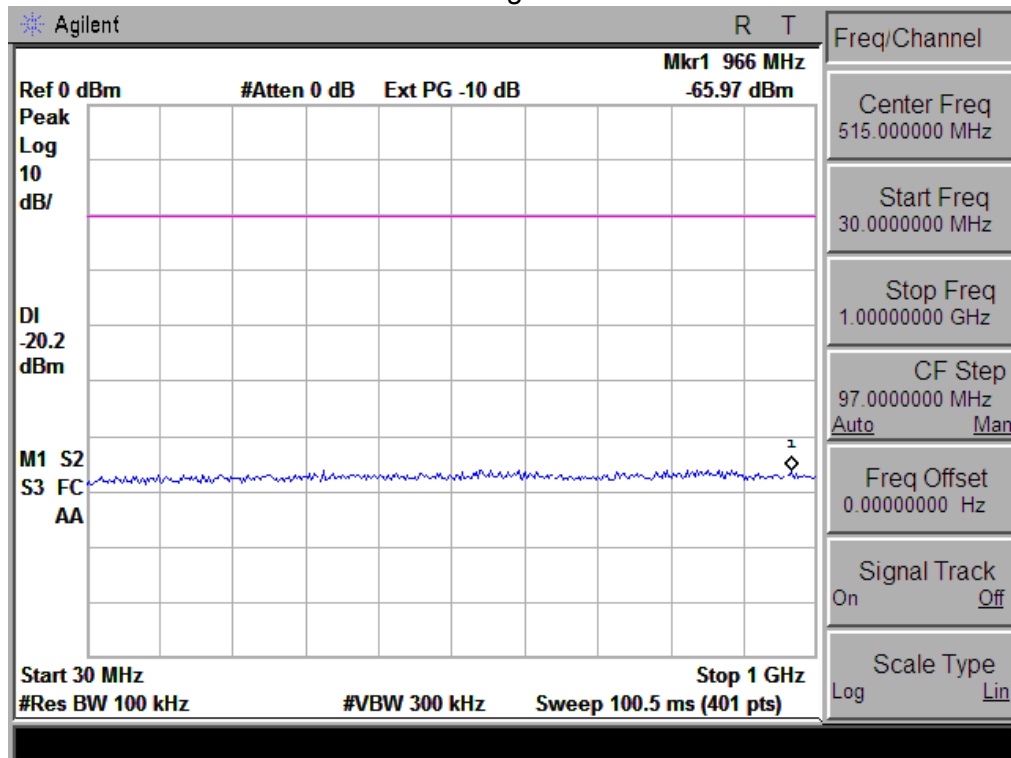

802.11g Low Channel

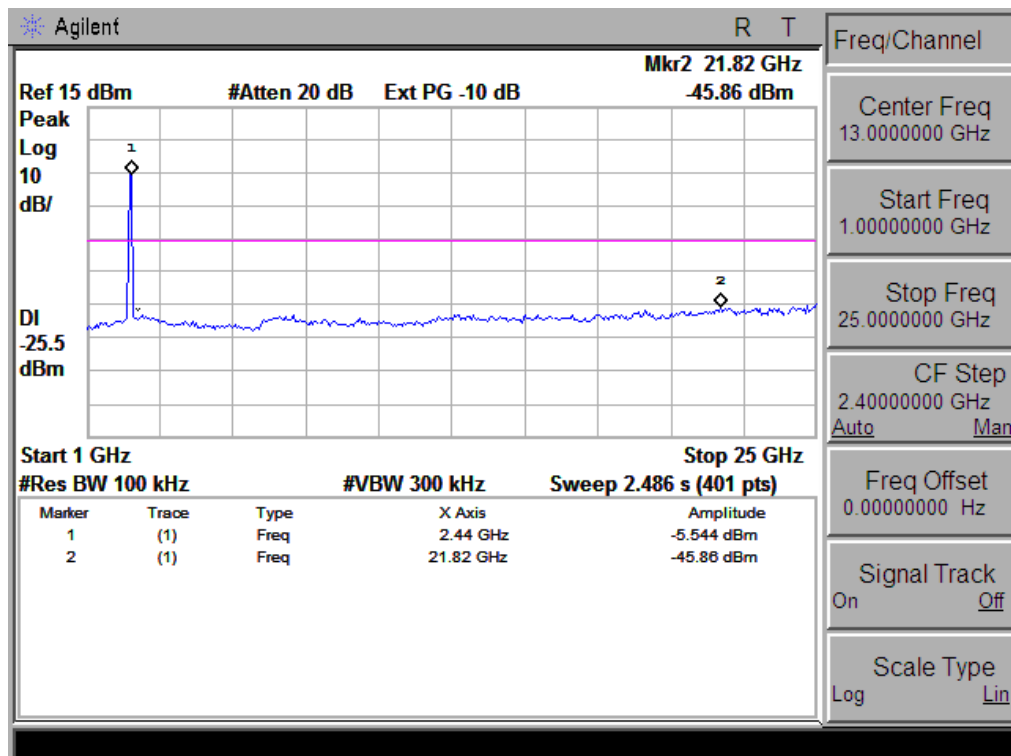
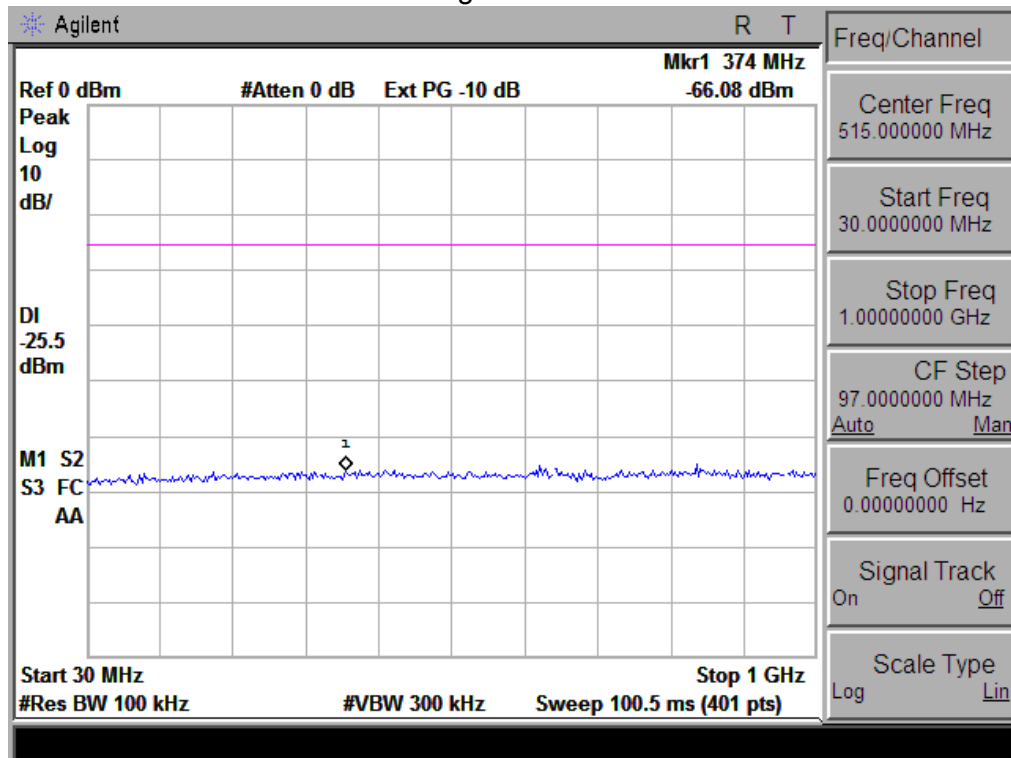

802.11g Middle Channel

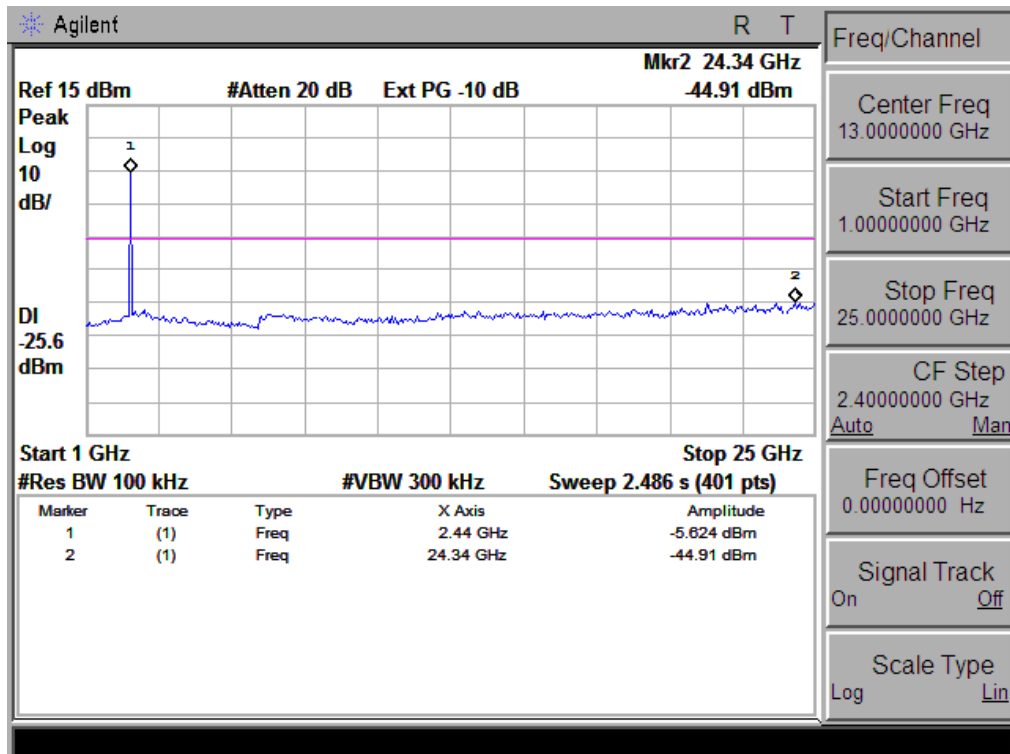
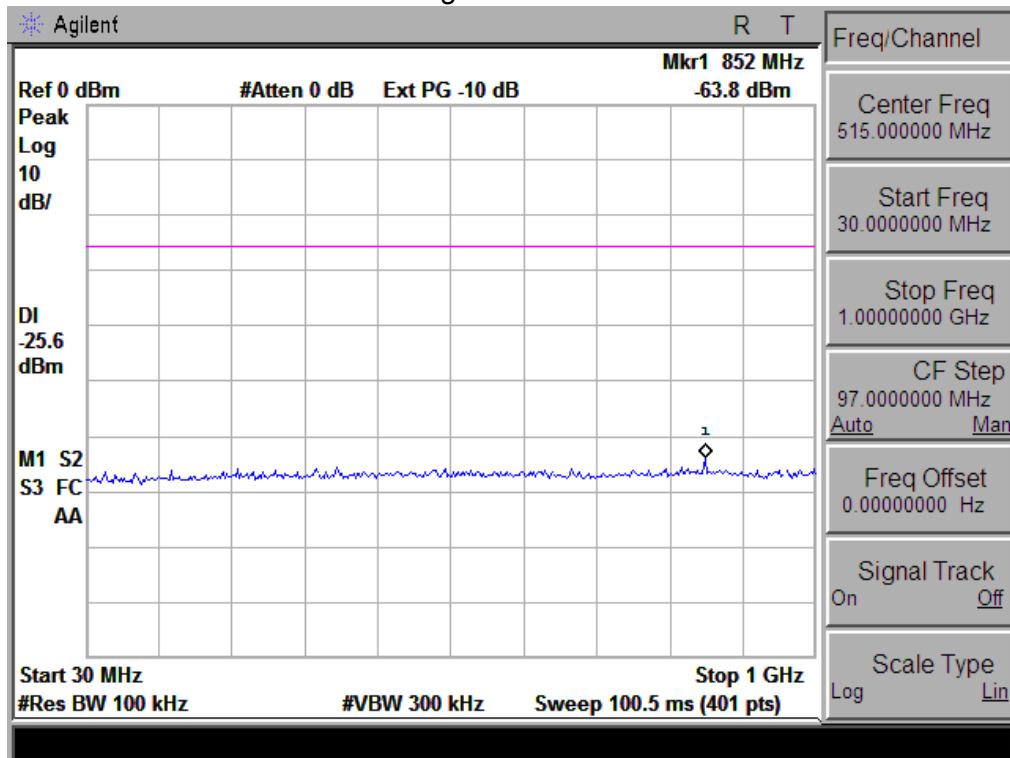

802.11g High Channel

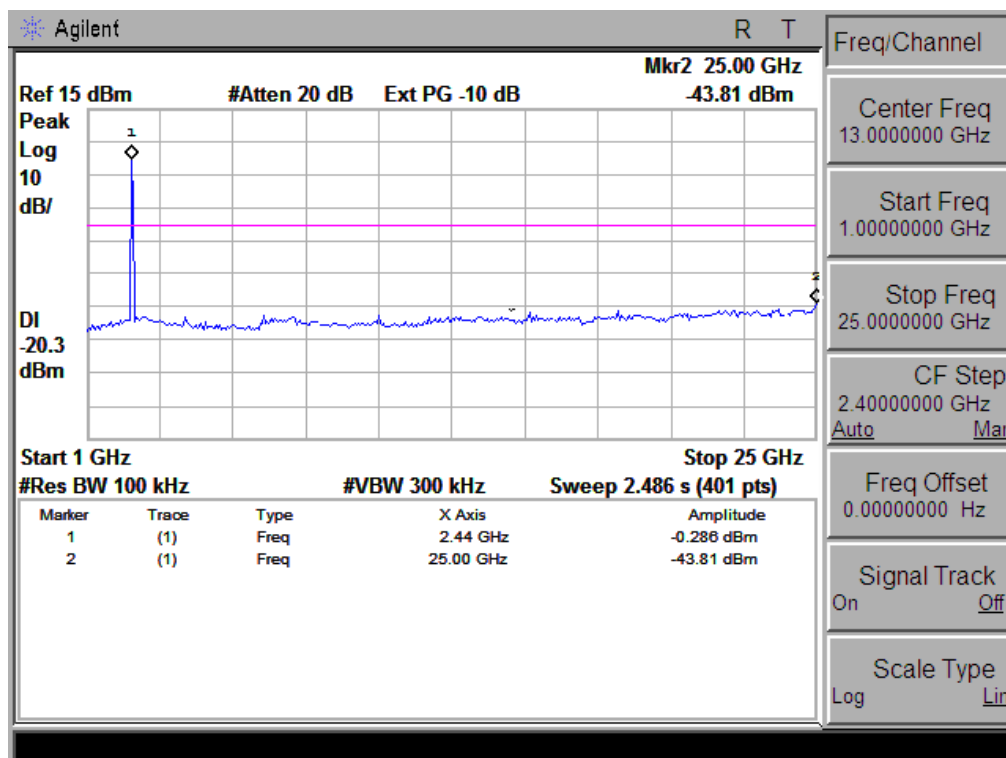
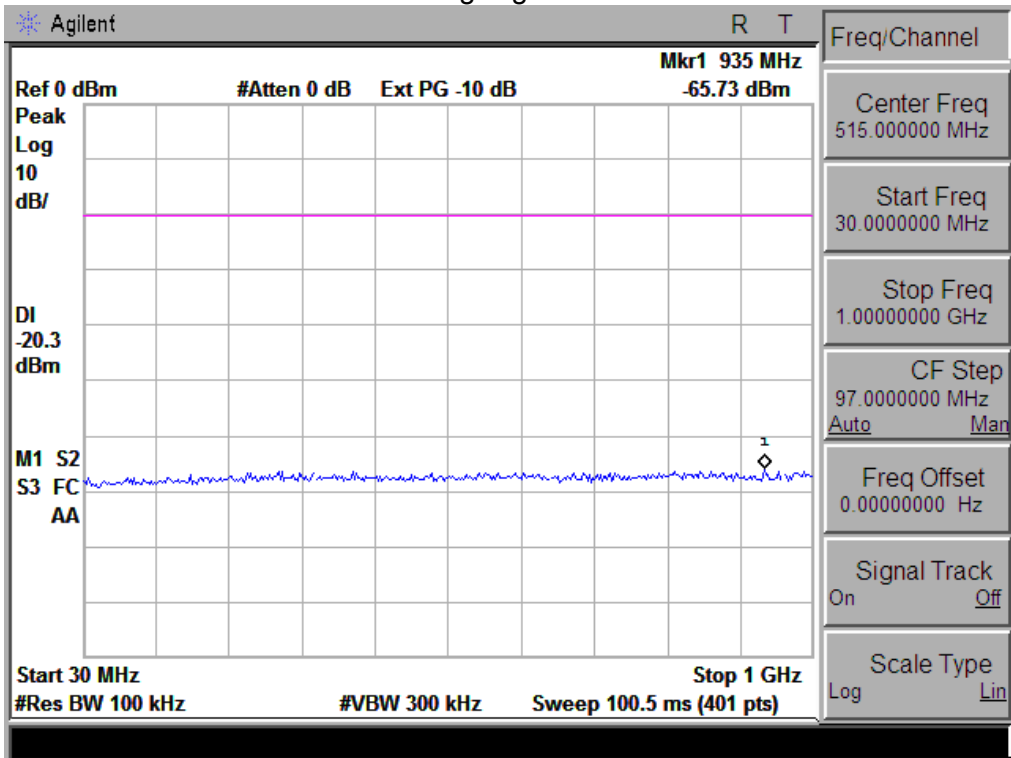

802.11n-HT20 Low Channel

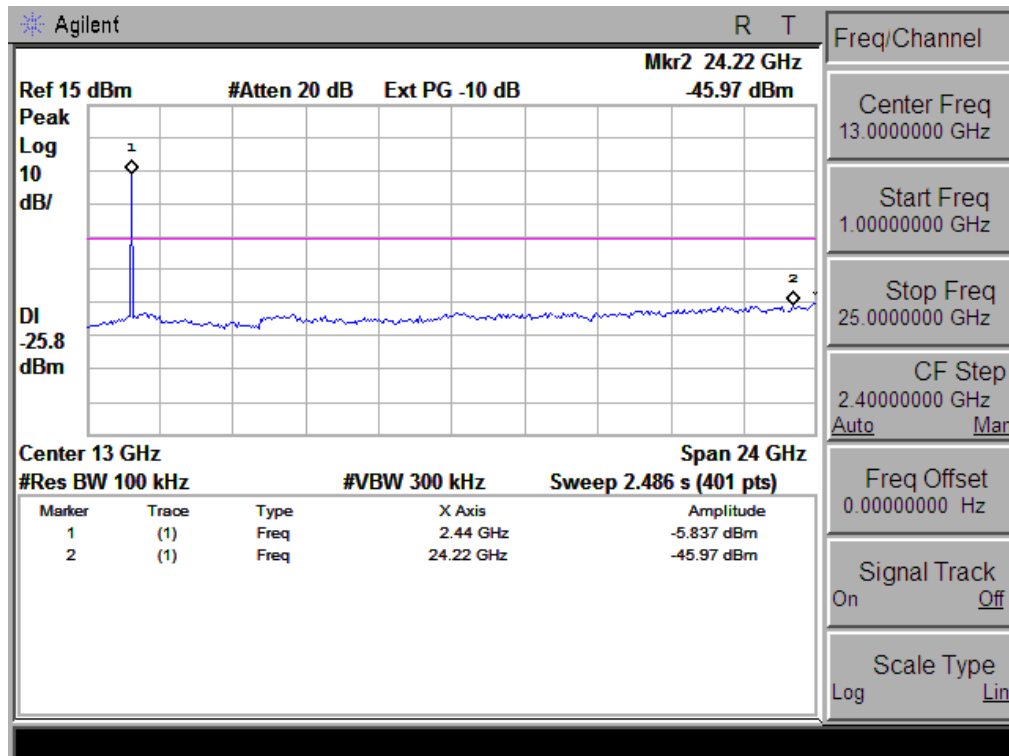
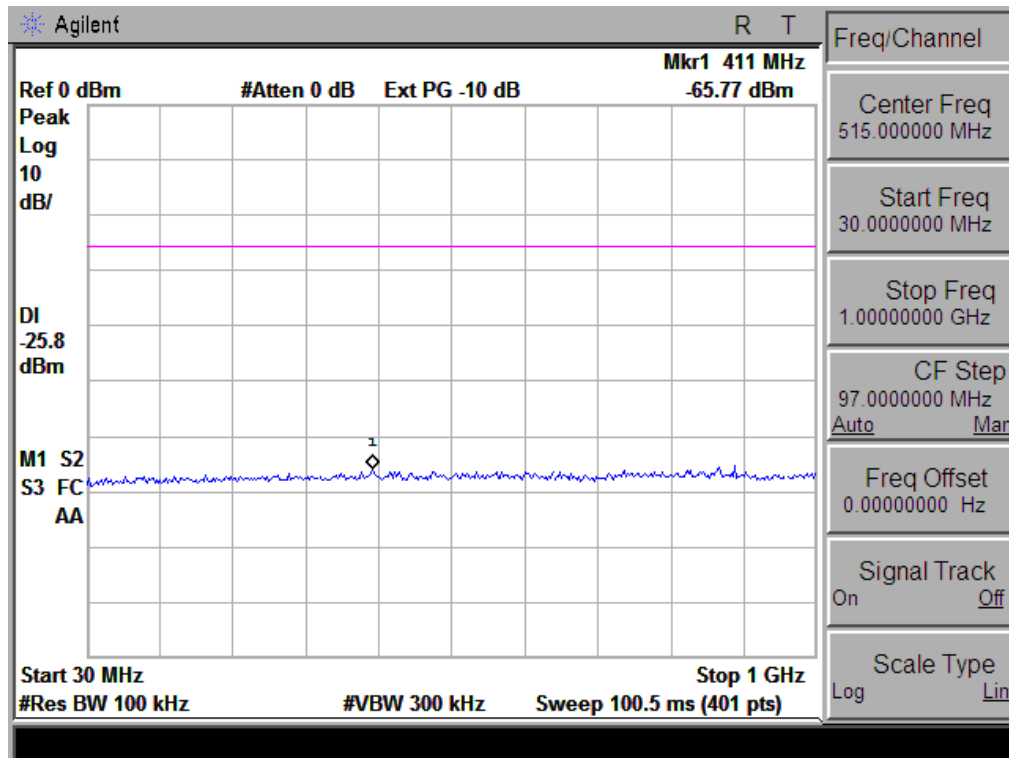

802.11n-HT20 Middle Channel

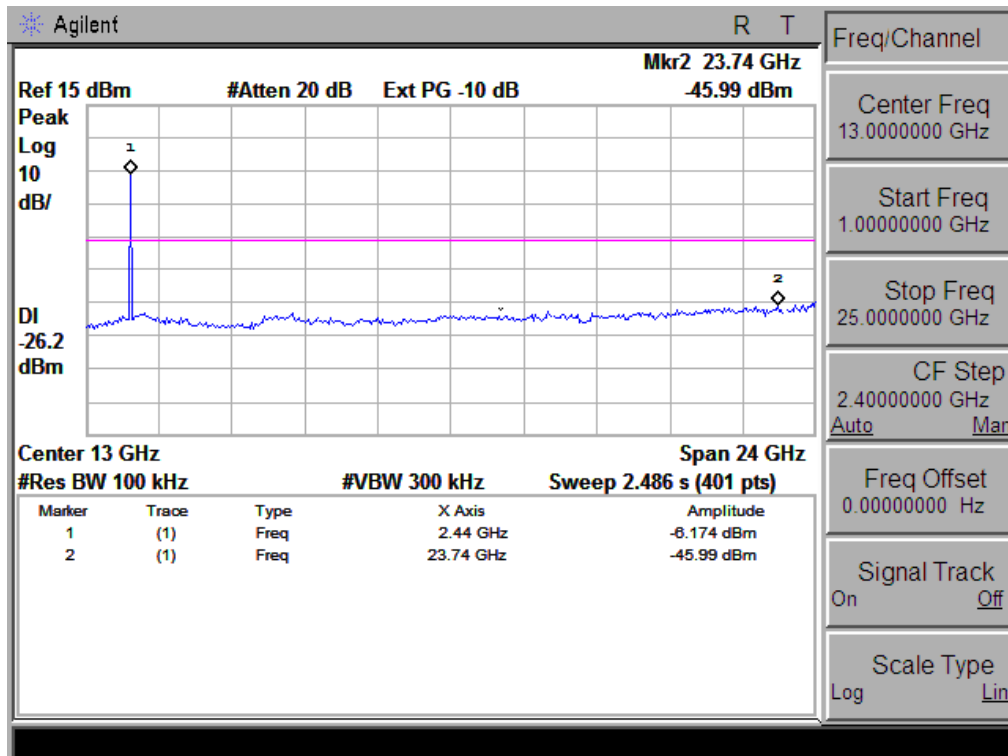
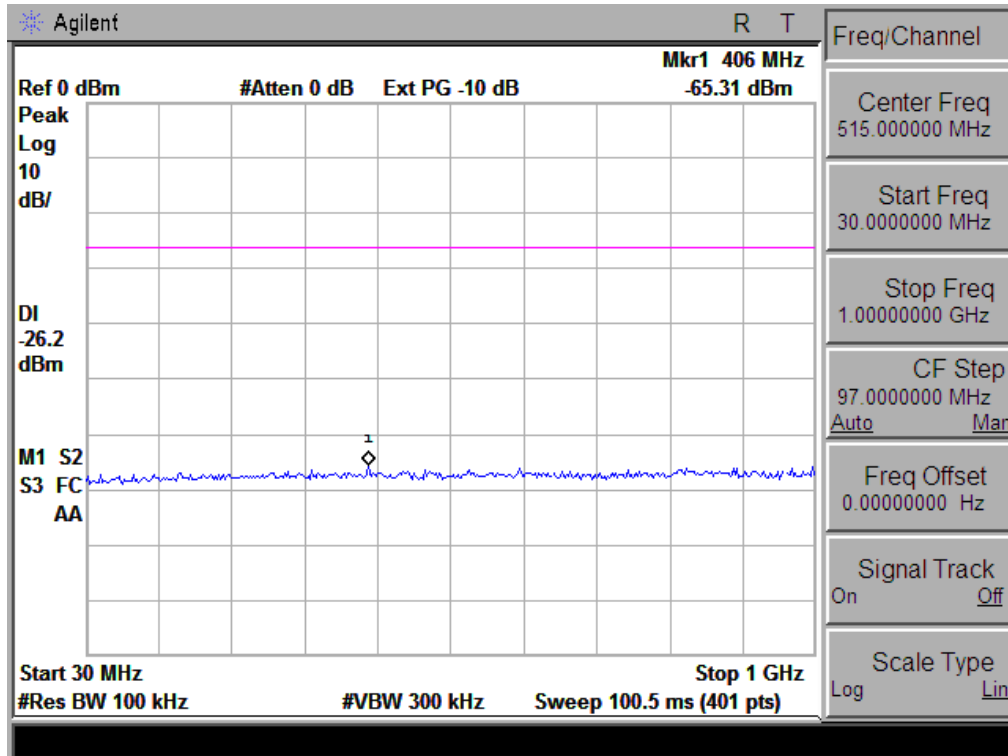

802.11n-HT20 High Channel

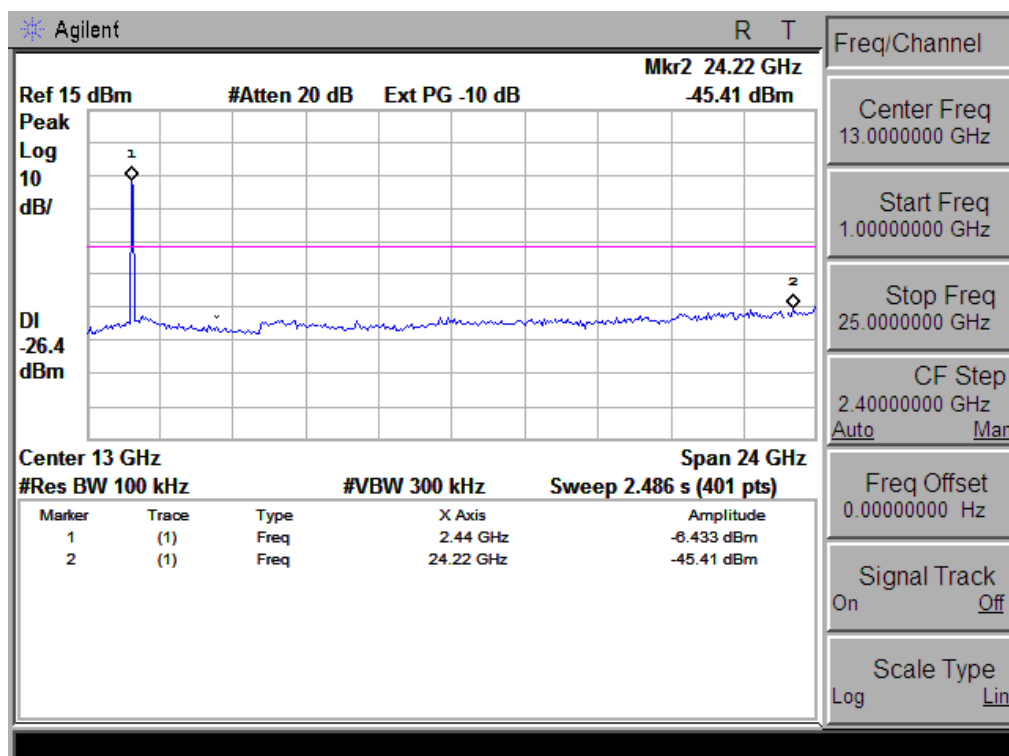
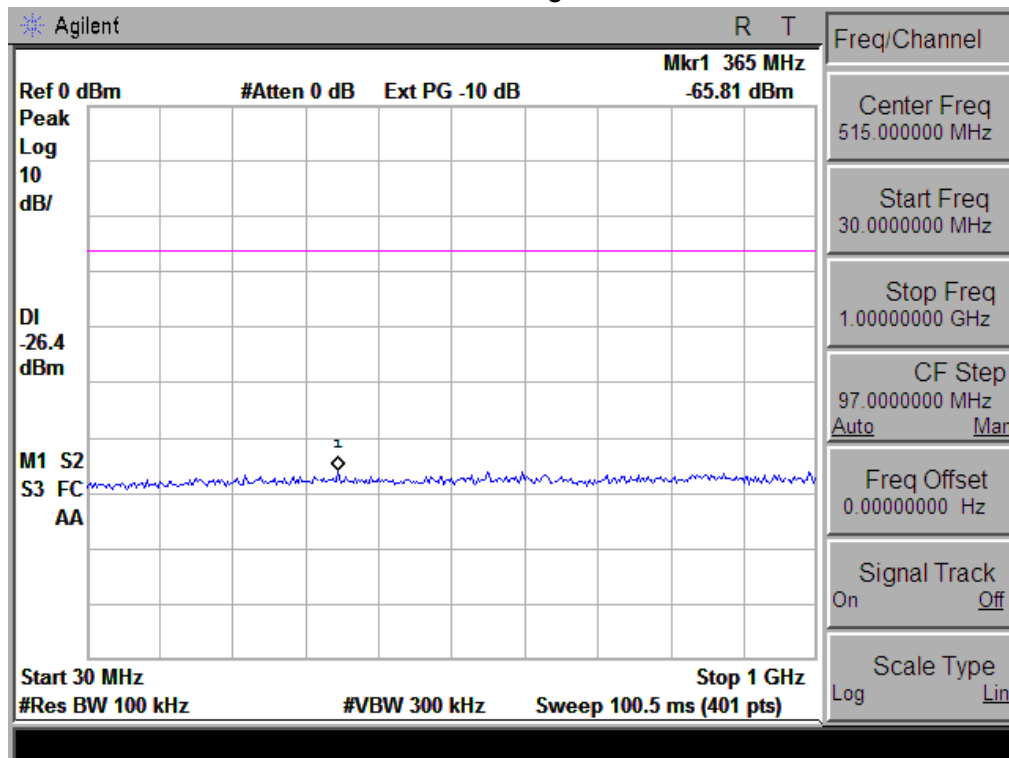

4. POWER SPECTRAL DENSITY TEST

4.1 APPLIED PROCEDURES / LIMIT

FCC Part15 (15.247) , Subpart C				
Section	Test Item	Limit	Frequency Range (MHz)	Result
15.247	Power Spectral Density	8 dBm (in any 3KHz)	2400-2483.5	PASS

4.1.1 TEST PROCEDURE

1. Set analyzer center frequency to DTS channel center frequency.
2. Set the span to 1.5 times the DTS channel bandwidth.
3. 3 kHz ≤ Set the RBW ≤ 100 kHz.
4. Set the VBW ≥ 3 x RBW.
5. Detector = peak.
6. Sweep time = auto couple.
7. Trace mode = max hold.
8. Allow trace to fully stabilize.
9. Use the peak marker function to determine the maximum amplitude level within the RBW.
10. If measured value exceeds limit, reduce RBW (no less than 3 kHz) and repeat.

4.1.2 DEVIATION FROM STANDARD

No deviation.

4.1.3 TEST SETUP

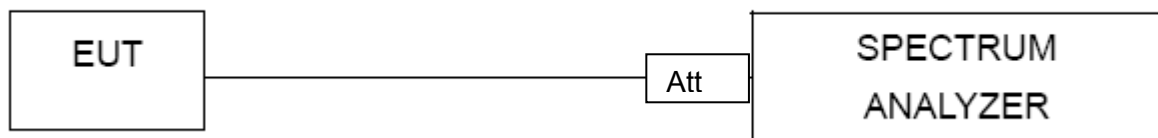

4.1.4 EUT OPERATION CONDITIONS

The EUT tested system was configured as the statements of 2.1 Unless otherwise a special operating condition is specified in the follows during the testing.

4.1.5 TEST RESULTS

EUT :	Streaming wireless speaker	Model Name :	HK OMNI 20
Temperature :	25 °C	Relative Humidity :	56%
Pressure :	1015 hPa	Test Voltage :	AC 120V/60Hz
Test Mode :	TX b Mode /CH01, CH06, CH11-Ant A		

Frequency	Power Density (dBm)	Limit (dBm)	Result
2412 MHz	-9.909	8	PASS
2437 MHz	-9.213	8	PASS
2462 MHz	-8.837	8	PASS

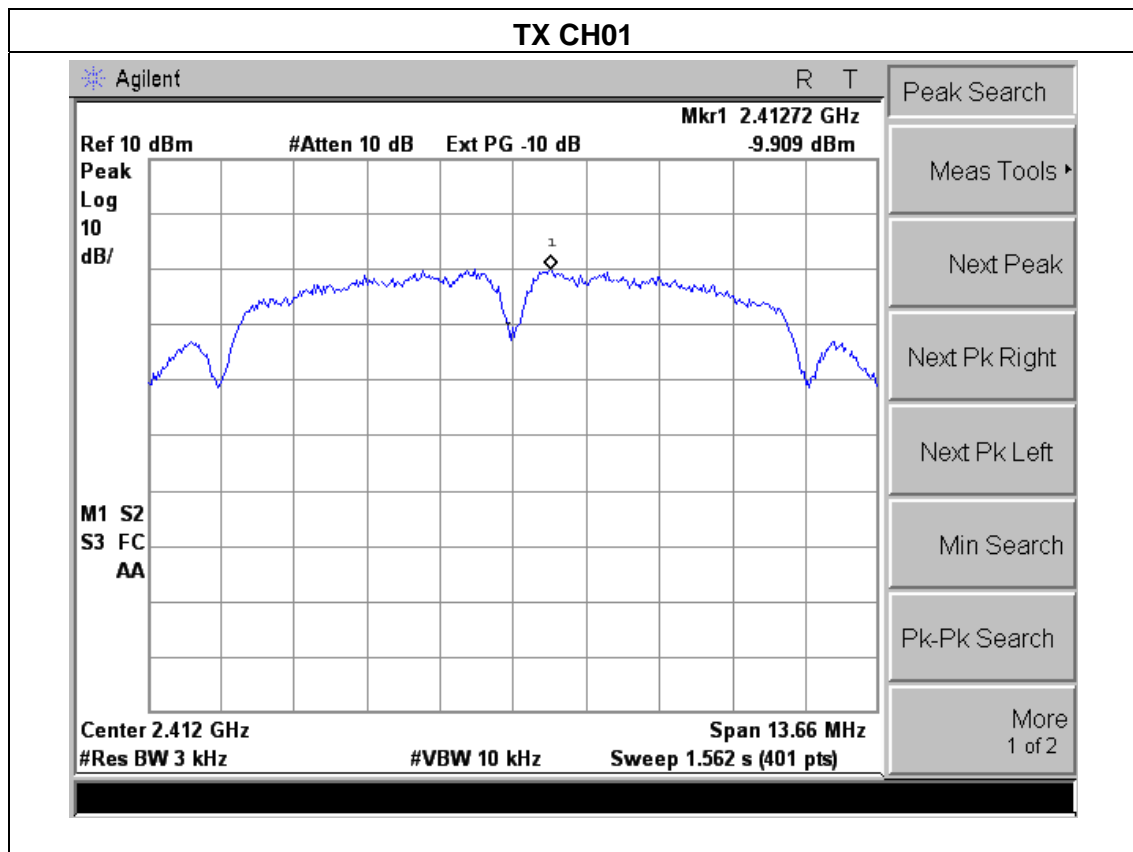

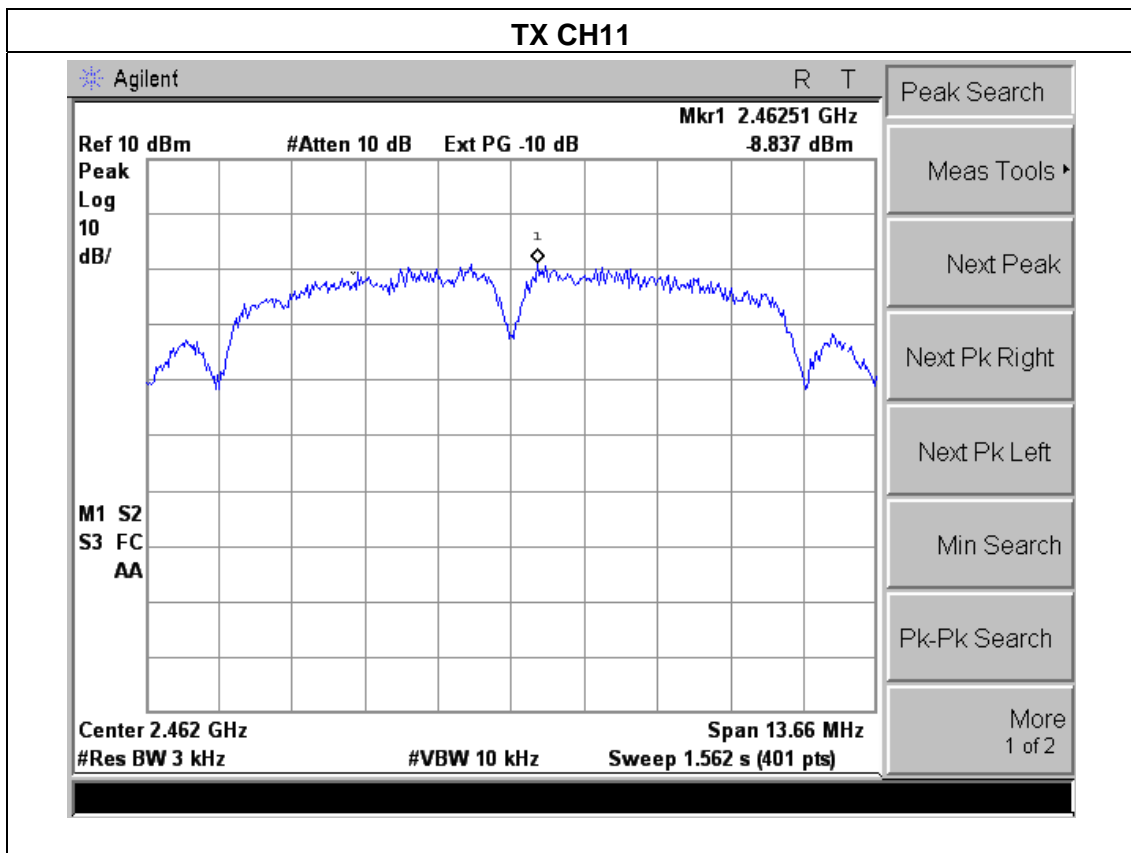
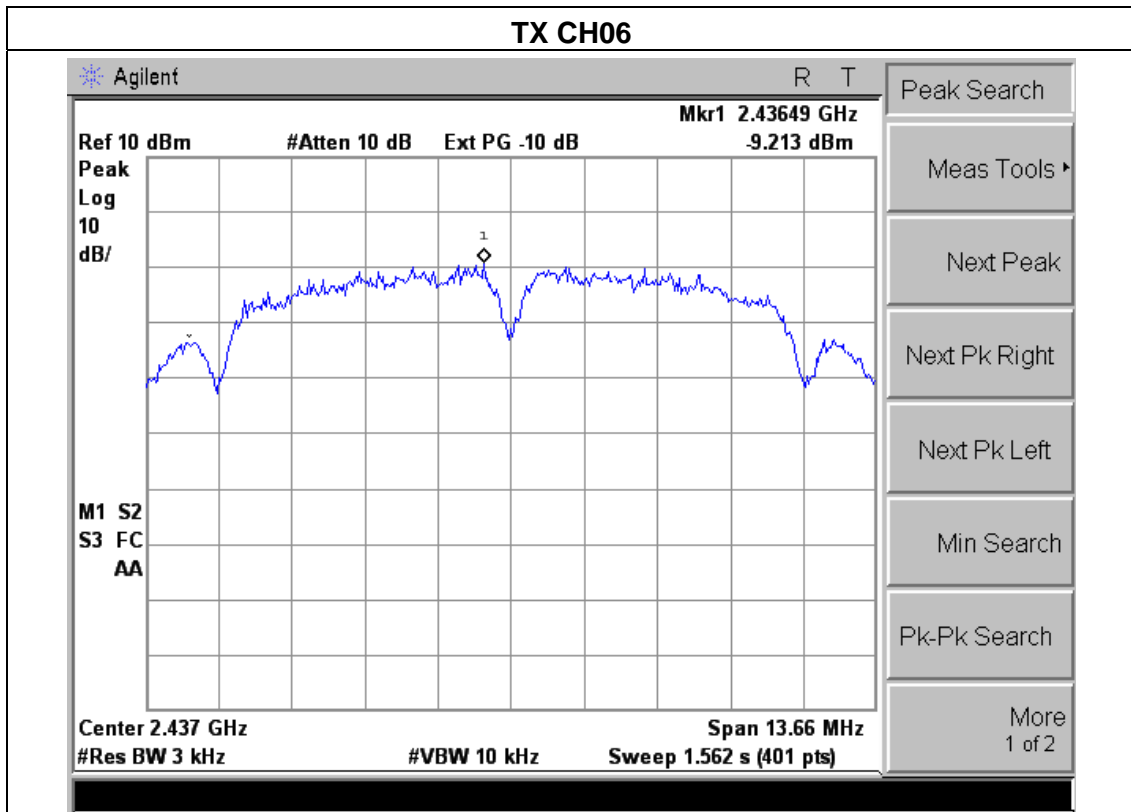

EUT :	Streaming wireless speaker	Model Name :	HK OMNI 20
Temperature :	25 °C	Relative Humidity :	56%
Pressure :	1015 hPa	Test Voltage :	AC 120V/60Hz
Test Mode :	TX g Mode /CH01, CH06, CH11-Ant A		

Frequency	Power Density (dBm)	Limit (dBm)	Result
2412 MHz	-12.81	8	PASS
2437 MHz	-12.74	8	PASS
2462 MHz	-11.38	8	PASS

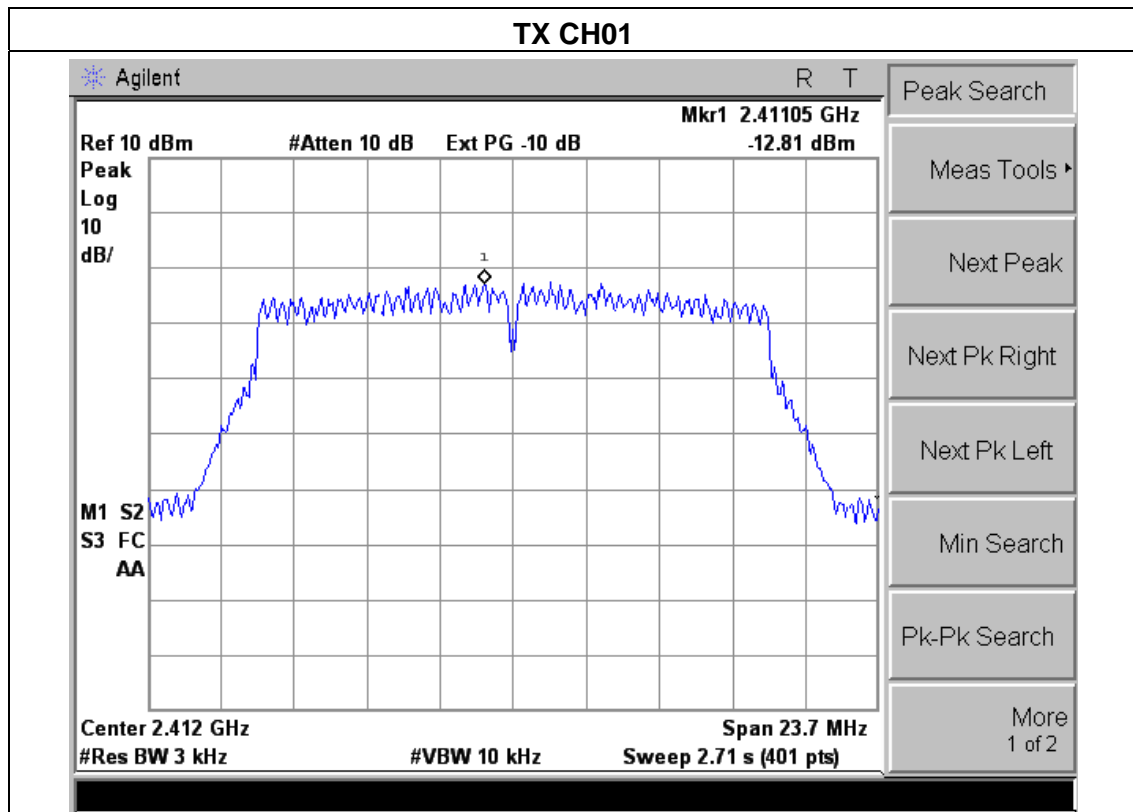

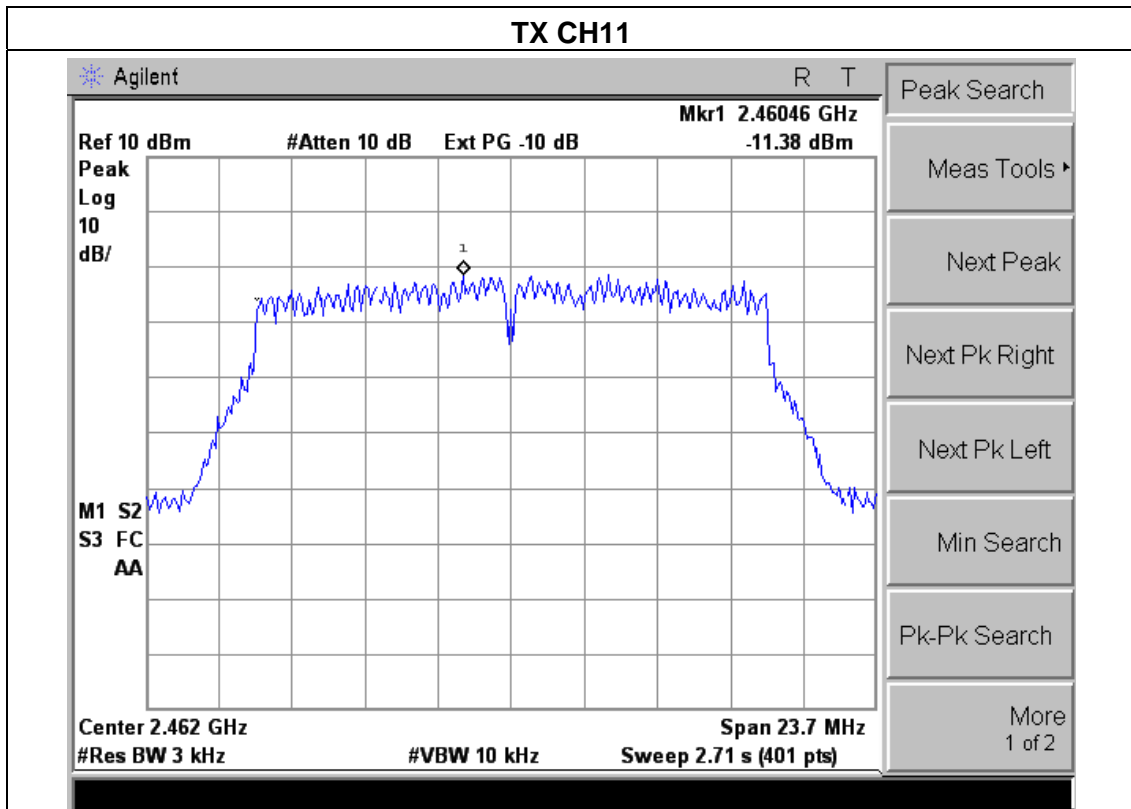
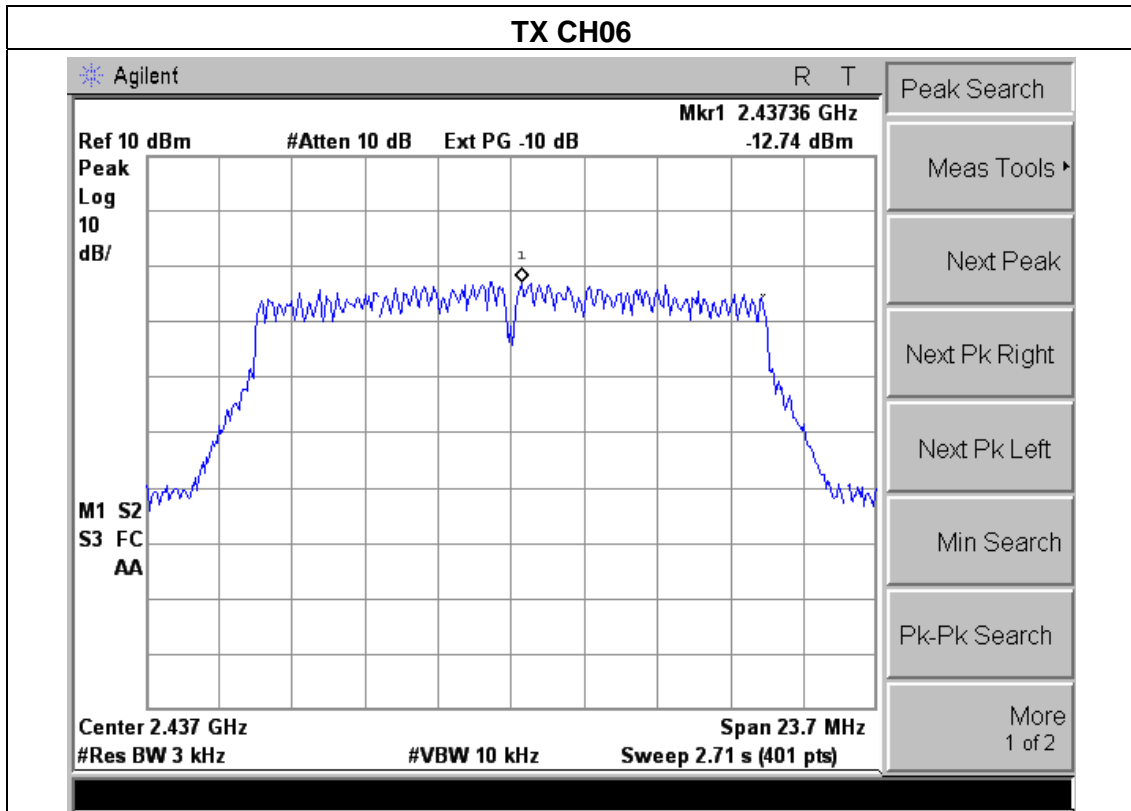

EUT :	Streaming wireless speaker	Model Name :	HK OMNI 20
Temperature :	25 °C	Relative Humidity :	56%
Pressure :	1015 hPa	Test Voltage :	AC 120V/60Hz
Test Mode :	TX n Mode(20M) /CH01, CH06, CH11-Ant A		

Frequency	Power Density (dBm)	Limit (dBm)	Result
2412 MHz	-15.65	8	PASS
2437 MHz	-15.15	8	PASS
2462 MHz	-15.19	8	PASS

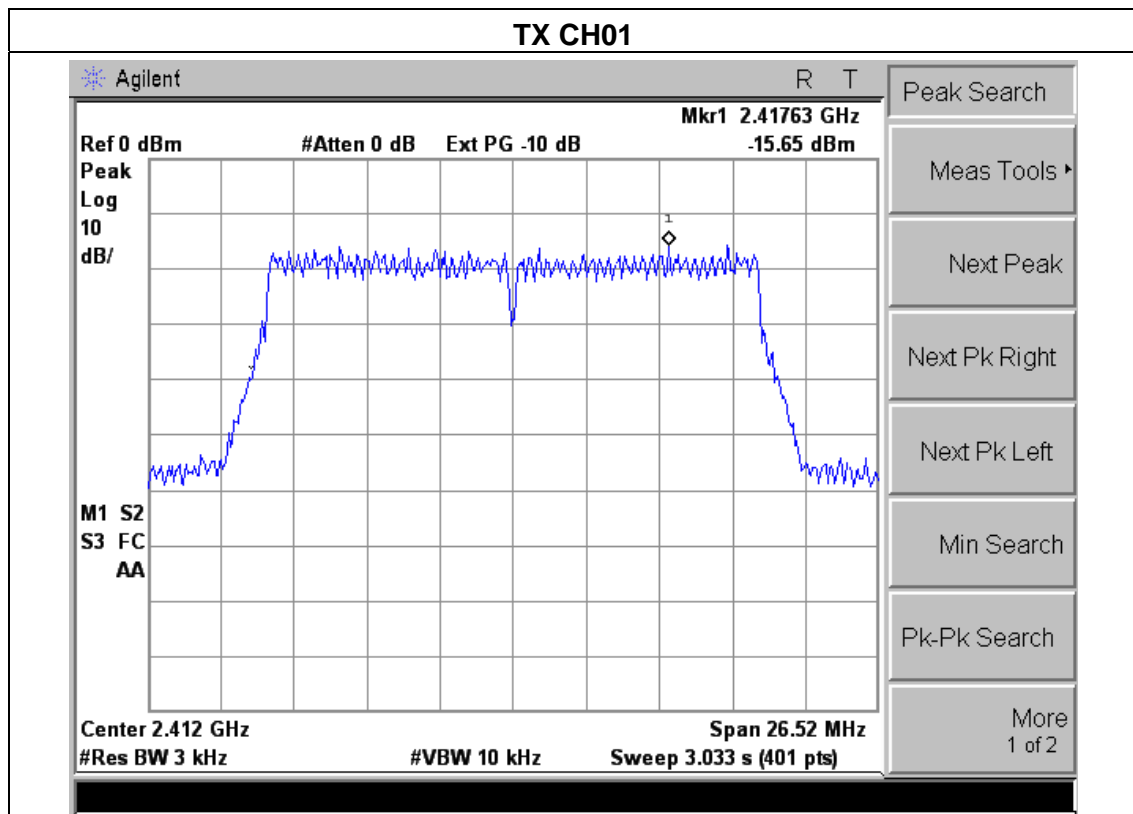

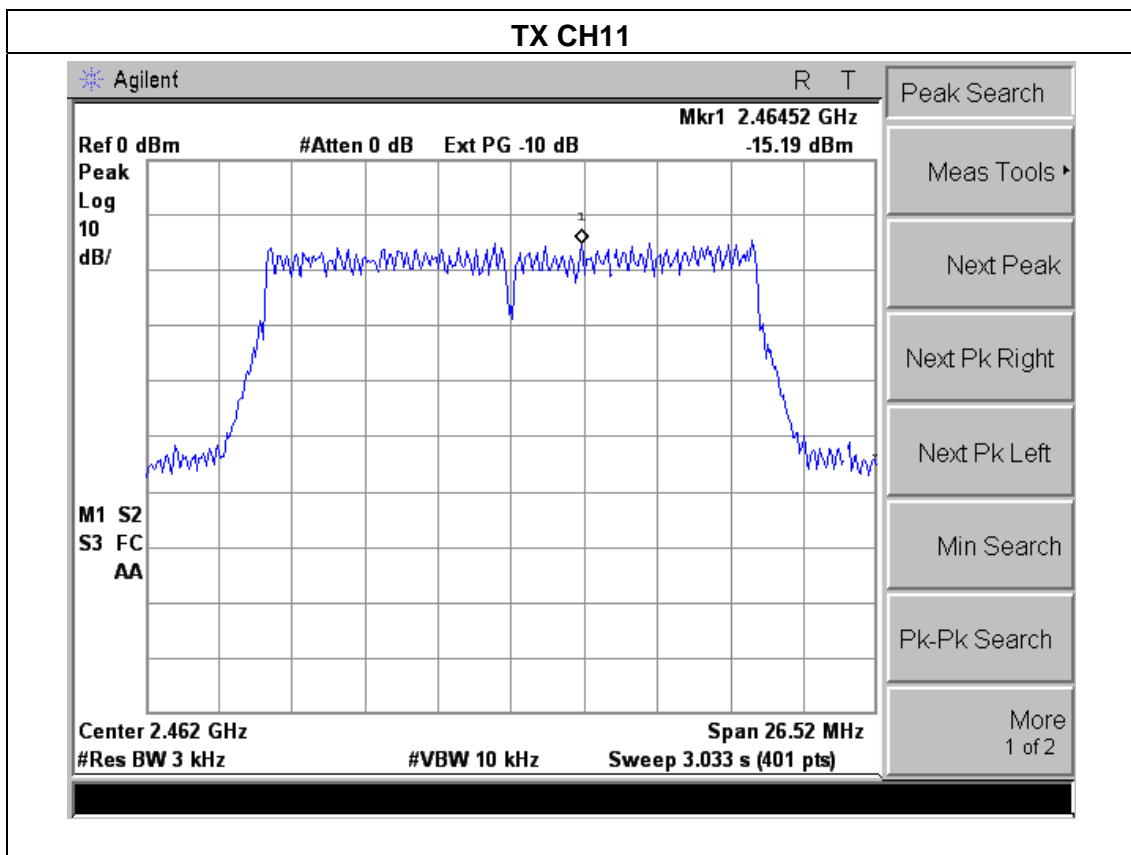
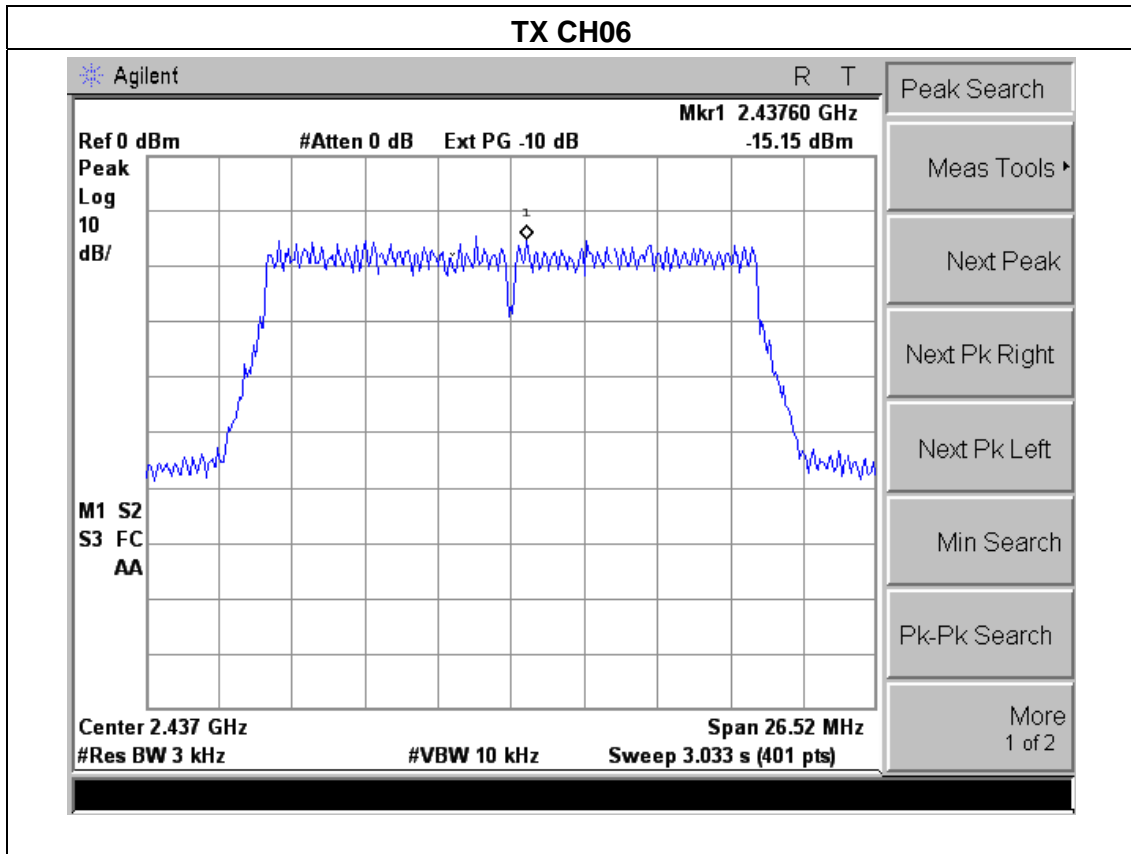

EUT :	Streaming wireless speaker	Model Name :	HK OMNI 20
Temperature :	25 °C	Relative Humidity :	56%
Pressure :	1015 hPa	Test Voltage :	AC 120V/60Hz
Test Mode :	TX b Mode /CH01, CH06, CH11-Ant B		

Frequency	Power Density (dBm)	Limit (dBm)	Result
2412 MHz	-13.90	8	PASS
2437 MHz	-13.77	8	PASS
2462 MHz	-13.53	8	PASS

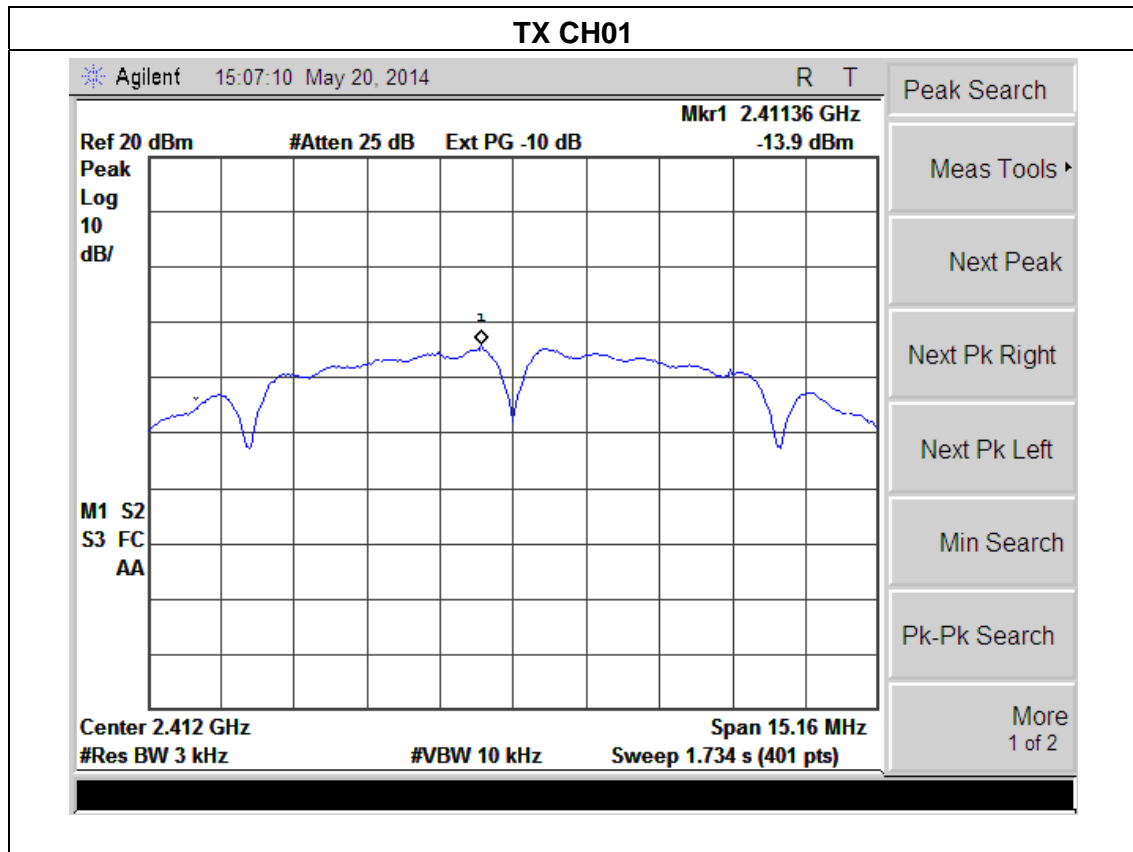

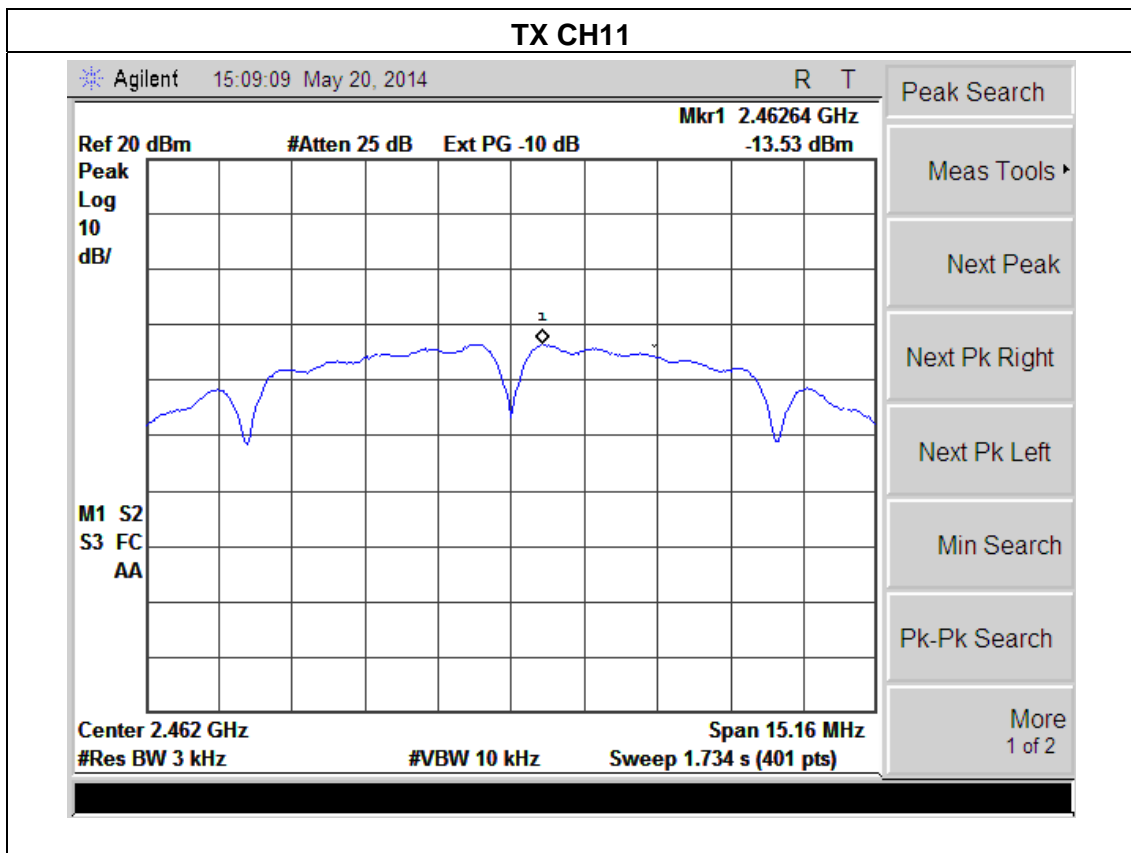
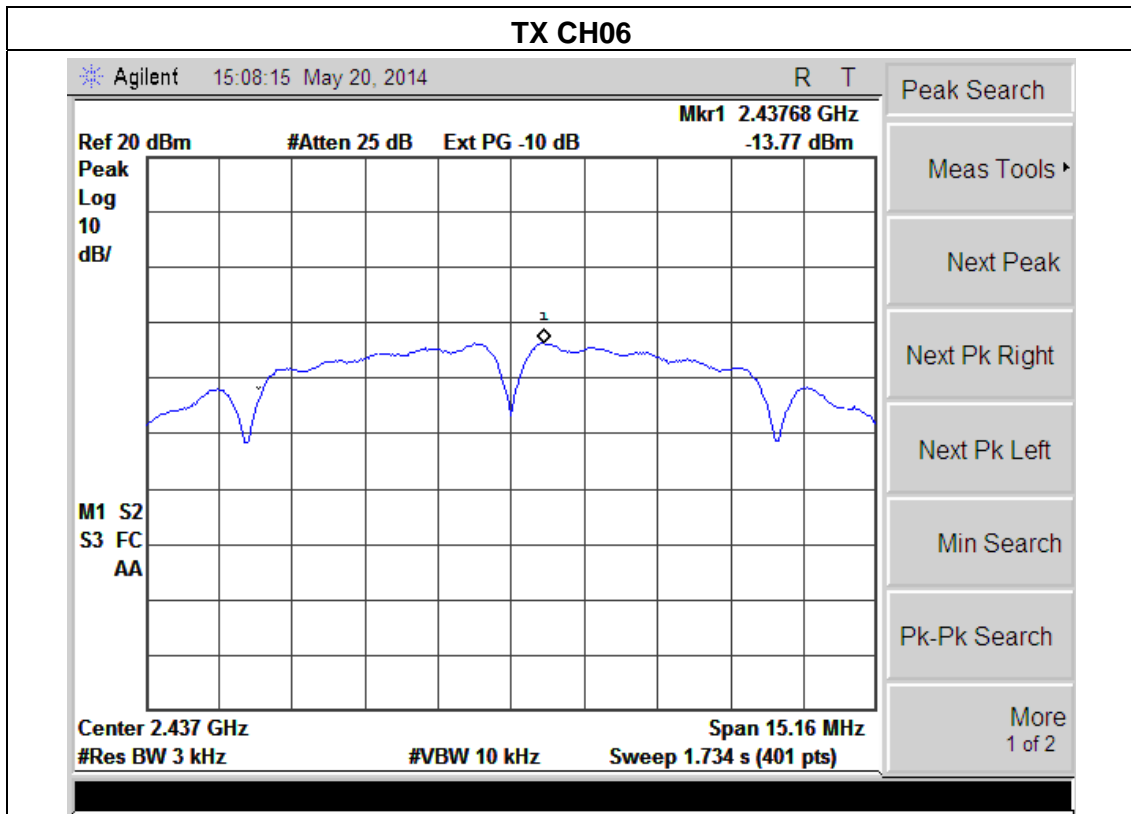

EUT :	Streaming wireless speaker	Model Name :	HK OMNI 20
Temperature :	25 °C	Relative Humidity :	56%
Pressure :	1015 hPa	Test Voltage :	AC 120V/60Hz
Test Mode :	TX g Mode /CH01, CH06, CH11-Ant B		

Frequency	Power Density (dBm)	Limit (dBm)	Result
2412 MHz	-18.51	8	PASS
2437 MHz	-18.82	8	PASS
2462 MHz	-19.10	8	PASS

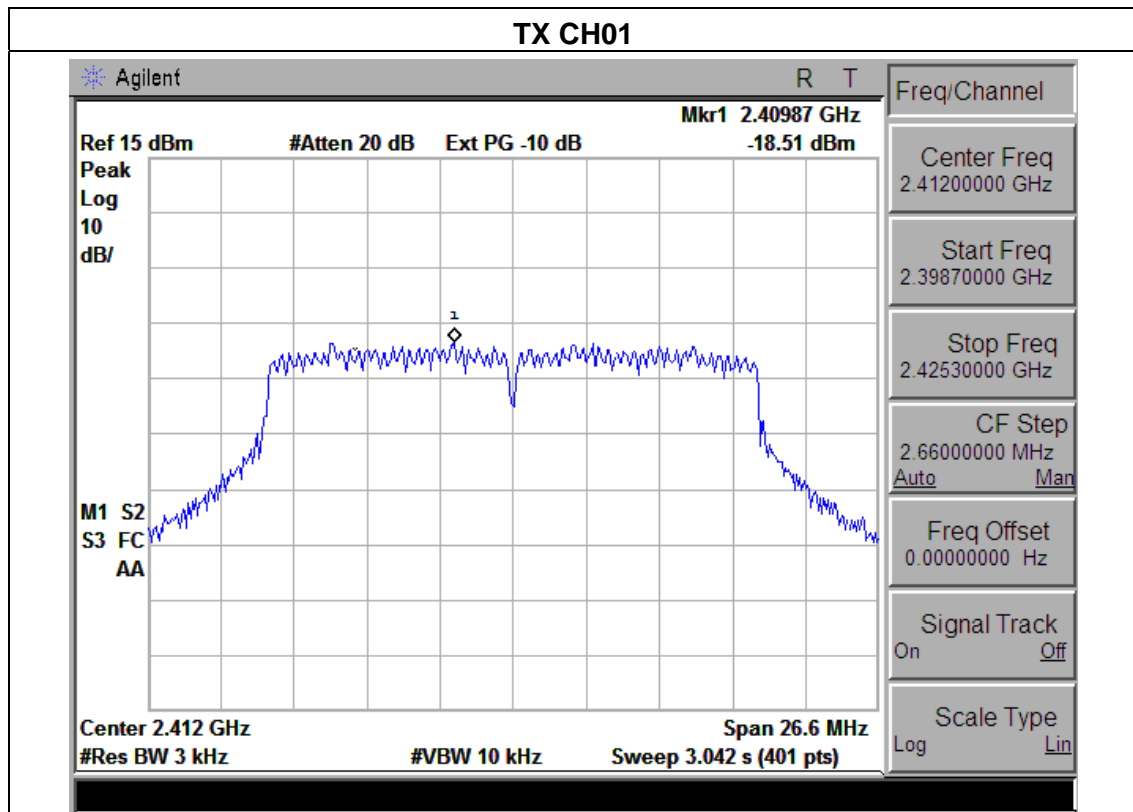

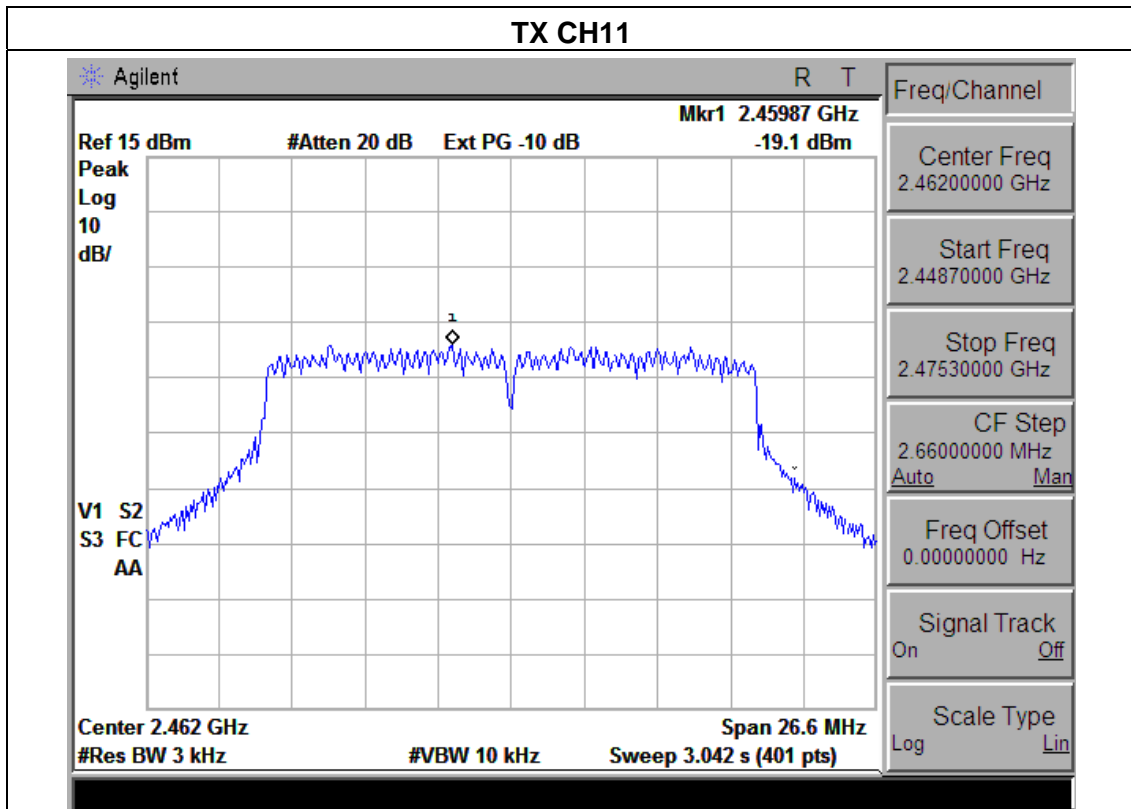
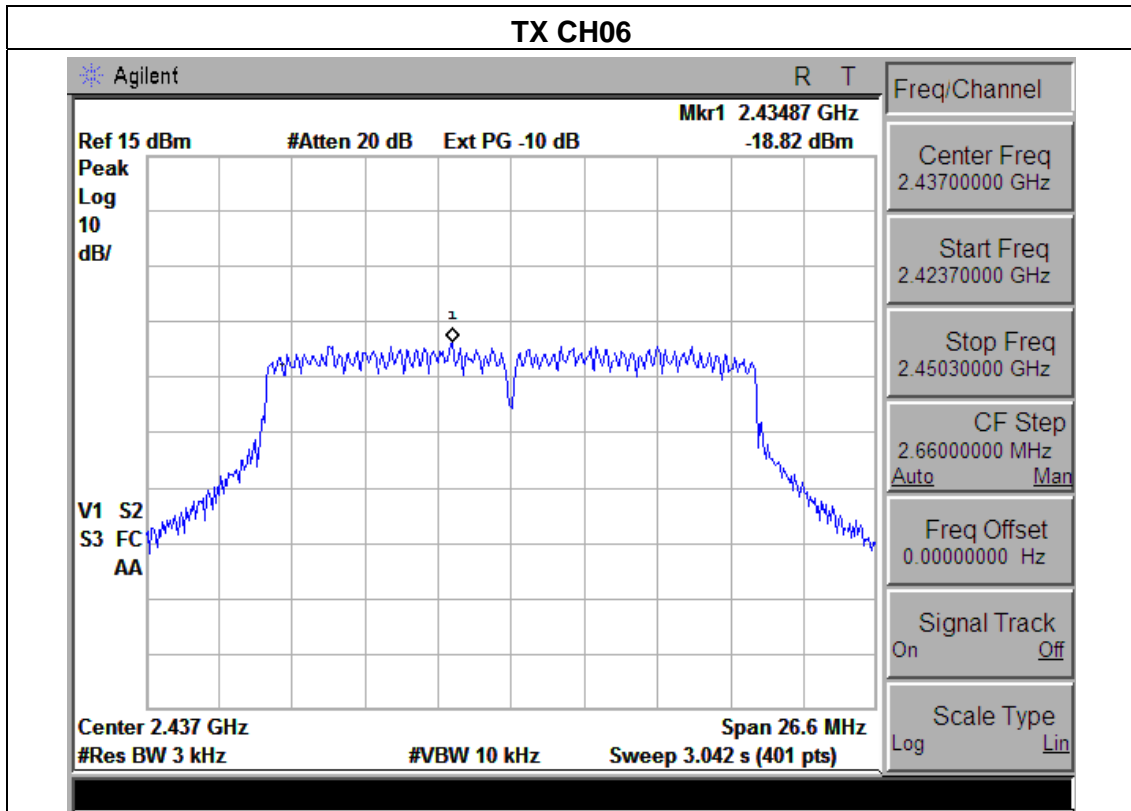

EUT :	Streaming wireless speaker	Model Name :	HK OMNI 20
Temperature :	25 °C	Relative Humidity :	56%
Pressure :	1015 hPa	Test Voltage :	AC 120V/60Hz
Test Mode :	TX n Mode(20M) /CH01, CH06, CH11-Ant B		

Frequency	Power Density (dBm)	Limit (dBm)	Result
2412 MHz	-18.33	8	PASS
2437 MHz	-19.09	8	PASS
2462 MHz	-19.33	8	PASS

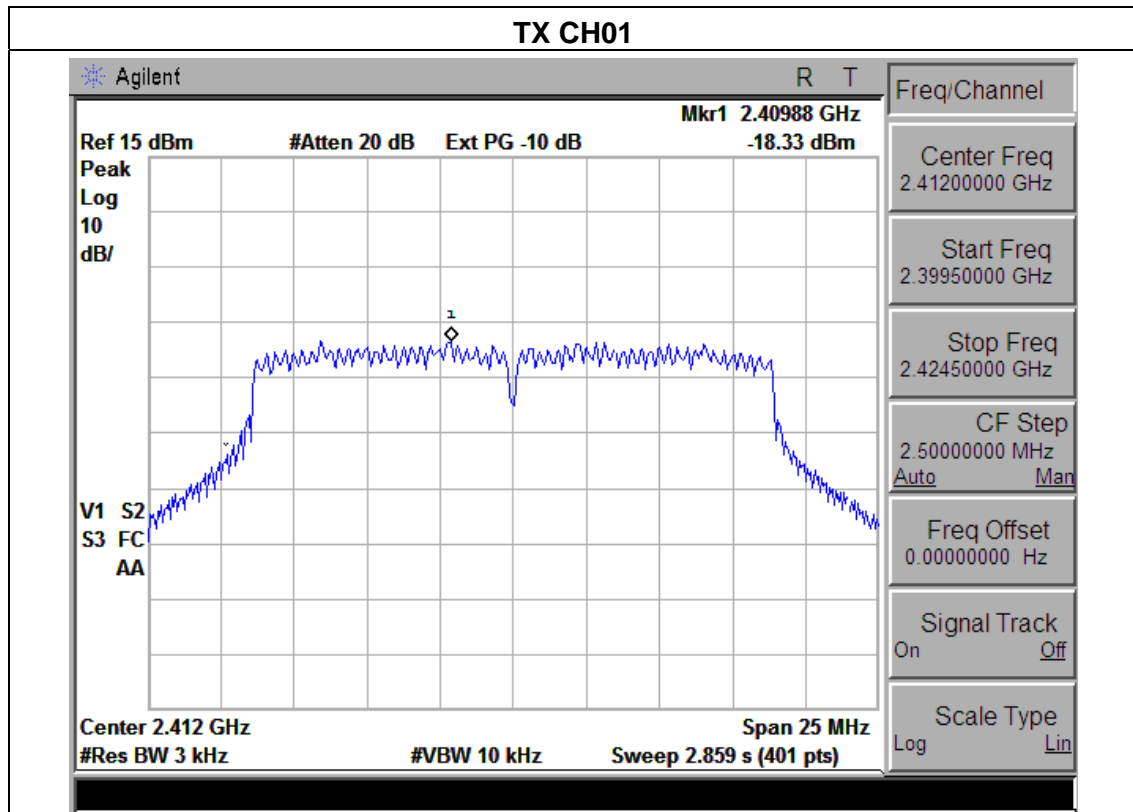

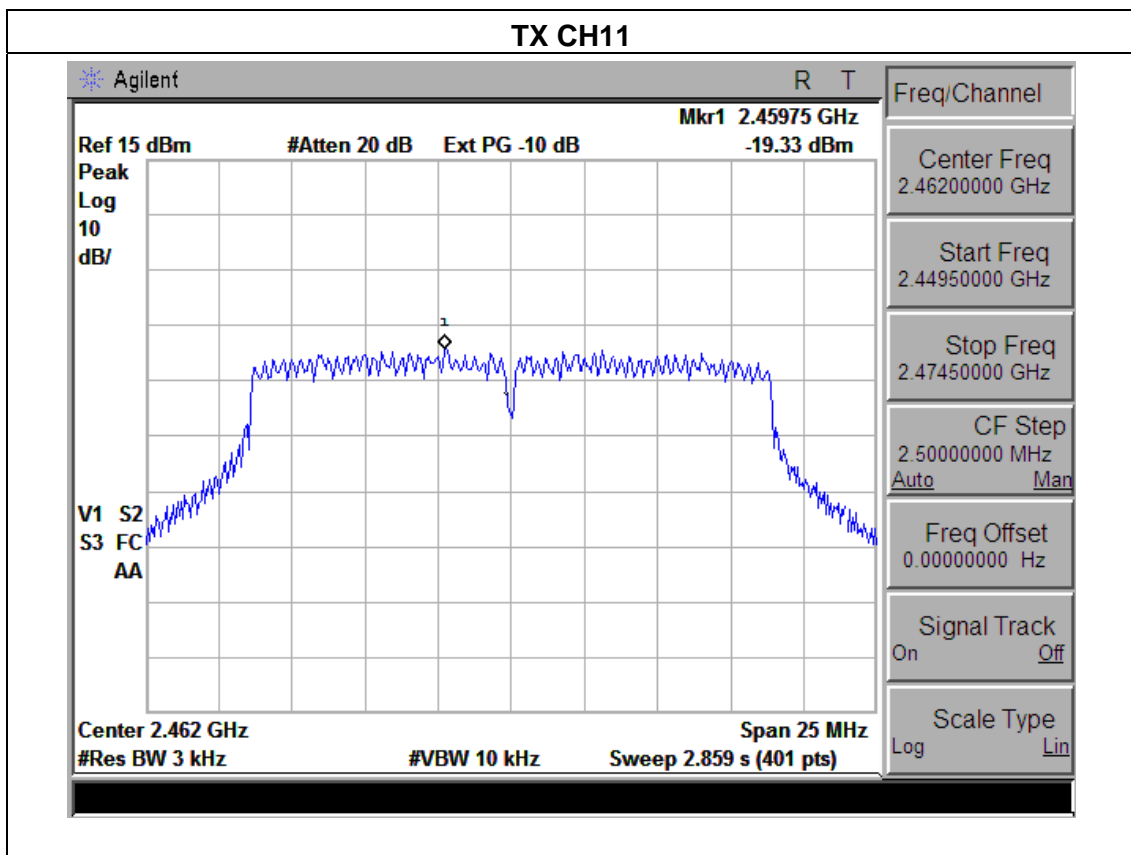
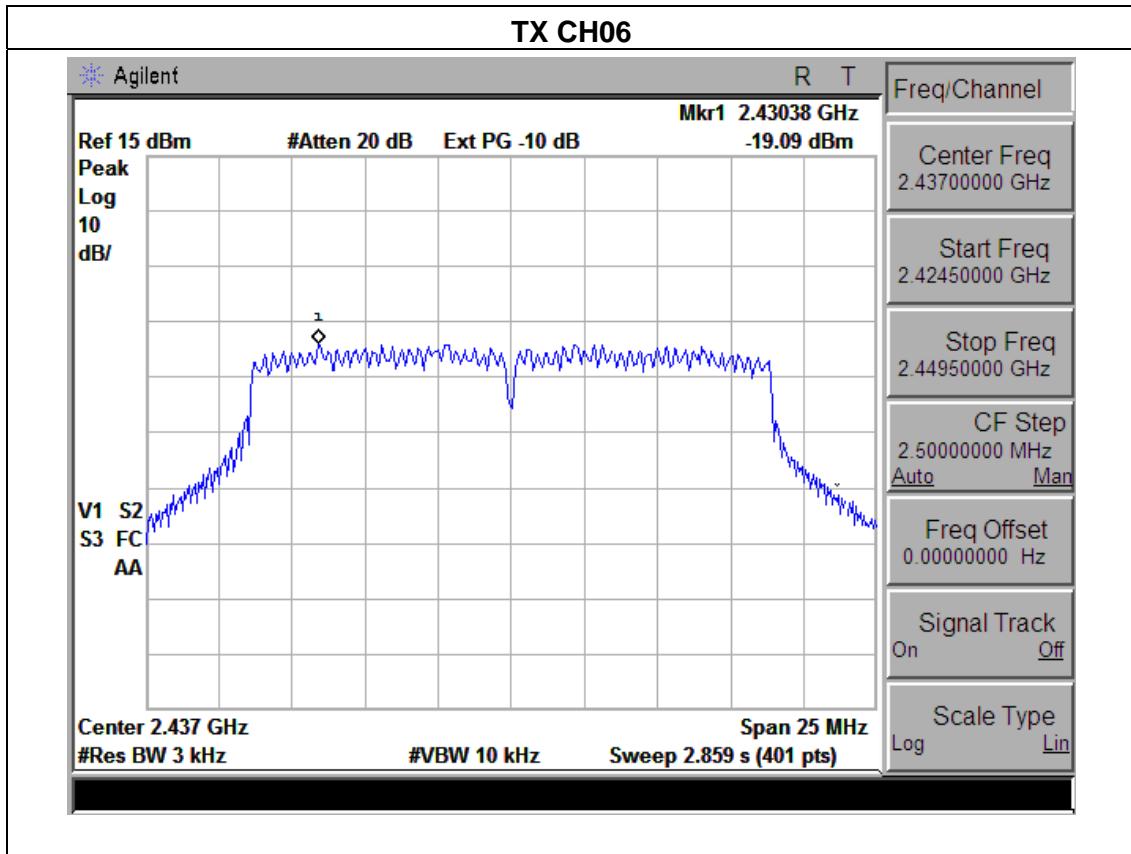

5. BANDWIDTH TEST

5.1 APPLIED PROCEDURES / LIMIT

FCC Part15 (15.247) , Subpart C				
Section	Test Item	Limit	Frequency Range (MHz)	Result
15.247(a)(2)	Bandwidth	$\geq 500\text{KHz}$ (6dB bandwidth)	2400-2483.5	PASS

5.1.1 TEST PROCEDURE

According to KDB 558074 D01 DTS Meas Guidance v03r01

1. Check the calibration of the measuring instrument using either an internal calibrator or a known signal from an external generator
2. Position the EUT without connection to measurement instrument. Turn on the EUT and connect it to measurement instrument. Then set it to any one convenient frequency within its operating range. Set a reference level on the measuring instrument equal to the highest peak value.
3. Measure the frequency difference of two frequencies that were attenuated 6 dB from the reference level. Record the frequency difference as the emission bandwidth.
4. Repeat above procedures until all frequencies measured were complete.

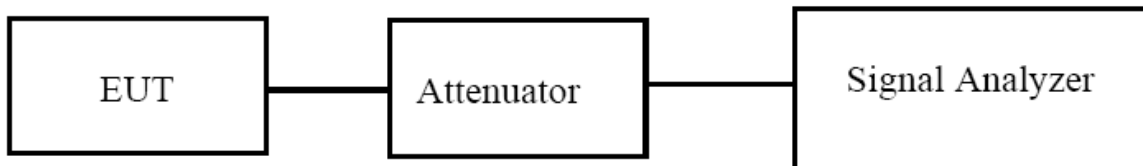

5.1.2 EUT OPERATION CONDITIONS

The EUT tested system was configured as the statements of 2.4 Unless otherwise a special operating condition is specified in the follows during the testing.

5.1.3 TEST RESULTS

EUT :	Streaming wireless speaker	Model Name :	HK OMNI 20
Temperature :	25 °C	Relative Humidity :	56%
Pressure :	1012 hPa	Test Voltage :	AC 120V/60Hz
Test Mode :	TX b Mode /CH01, CH06, CH11-Ant A		

Channel	Frequency (MHz)	6dB bandwidth (MHz)	Limit (kHz)	Result
Low	2412	9.107	500	Pass
Middle	2437	9.103	500	Pass
High	2462	9.028	500	Pass

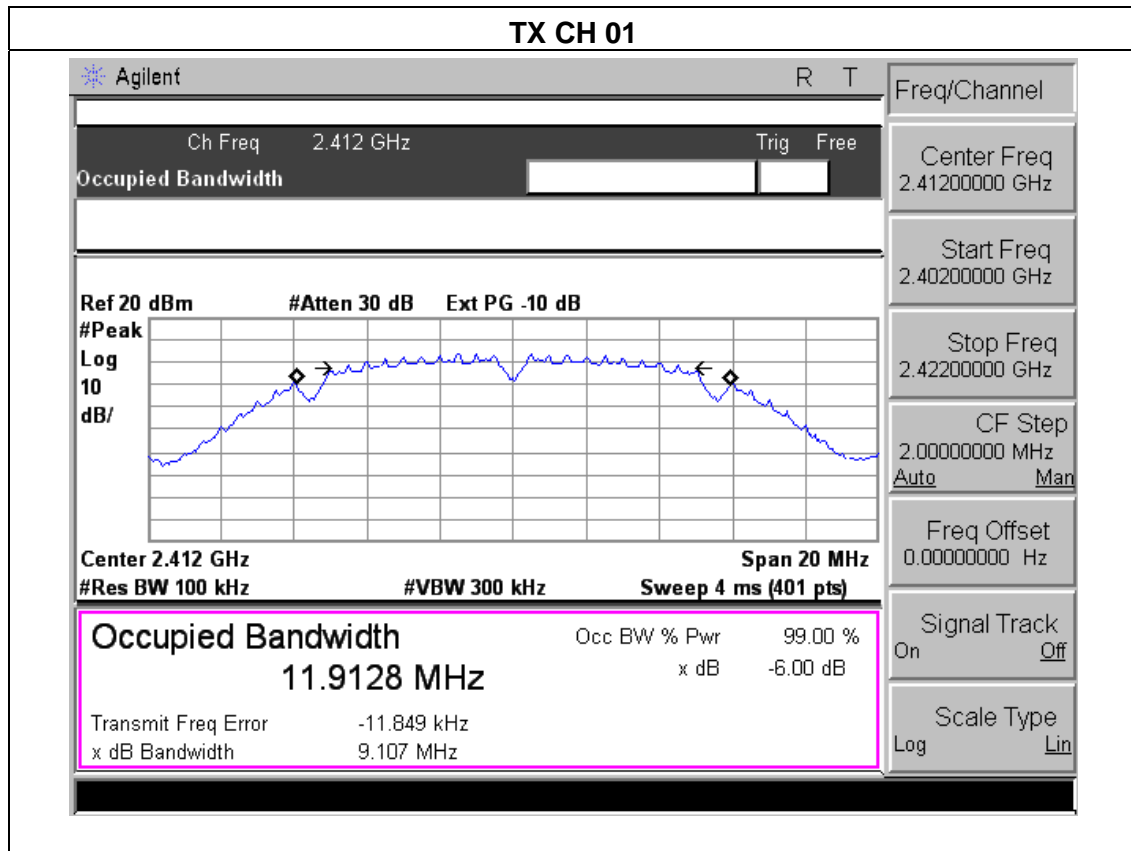

TX CH 06

Agilent		R	T	Freq/Channel	
Ch Freq 2.437 GHz		Trig Free		Center Freq 2.43700000 GHz	
Occupied Bandwidth				Start Freq 2.42700000 GHz	
Ref 20 dBm #Atten 30 dB Ext PG -10 dB				Stop Freq 2.44700000 GHz	
				CF Step 2.00000000 MHz Auto Man	
Center 2.437 GHz		Span 20 MHz		Freq Offset 0.00000000 Hz	
#Res BW 100 kHz		#VBW 300 kHz		Sweep 4 ms (401 pts)	
Occupied Bandwidth 13.0407 MHz		Occ BW % Pwr 99.00 %		x dB -6.00 dB	
Transmit Freq Error 14.103 kHz				Signal Track On Off	
x dB Bandwidth 9.103 MHz				Scale Type Log Lin	

TX CH 11

Agilent		R	T	Freq/Channel	
Ch Freq 2.462 GHz		Trig Free		Center Freq 2.46200000 GHz	
Occupied Bandwidth				Start Freq 2.45200000 GHz	
Ref 20 dBm #Atten 30 dB Ext PG -10 dB				Stop Freq 2.47200000 GHz	
				CF Step 2.00000000 MHz Auto Man	
Center 2.462 GHz		Span 20 MHz		Freq Offset 0.00000000 Hz	
#Res BW 100 kHz		#VBW 300 kHz		Sweep 4 ms (401 pts)	
Occupied Bandwidth 11.9356 MHz		Occ BW % Pwr 99.00 %		x dB -6.00 dB	
Transmit Freq Error 27.380 kHz				Signal Track On Off	
x dB Bandwidth 9.028 MHz				Scale Type Log Lin	

EUT :	Streaming wireless speaker	Model Name :	HK OMNI 20
Temperature :	25 °C	Relative Humidity :	60%
Pressure :	1012 hPa	Test Voltage :	AC 120V/60Hz
Test Mode :	TX g Mode /CH01, CH06, CH11-Ant A		

Channel	Frequency (MHz)	6dB bandwidth (MHz)	Limit (kHz)	Result
Low	2412	15.801	500	Pass
Middle	2437	15.726	500	Pass
High	2462	15.795	500	Pass

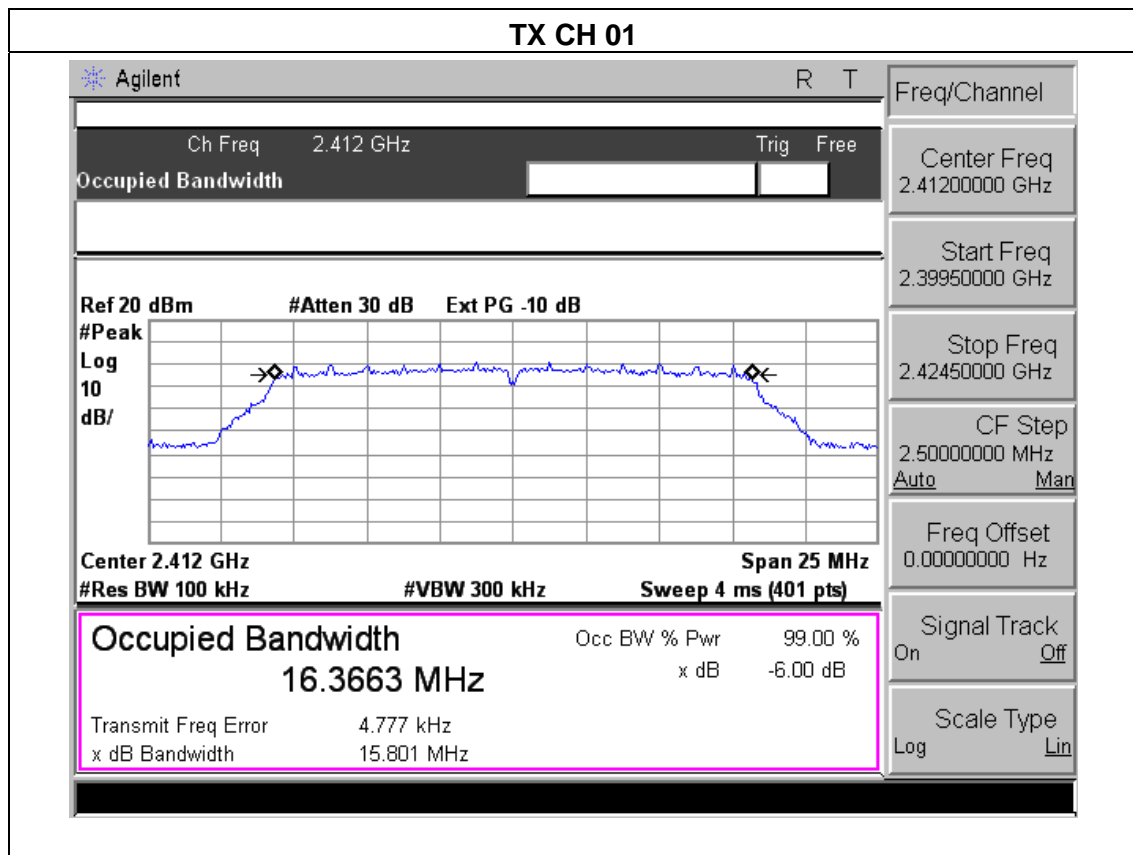

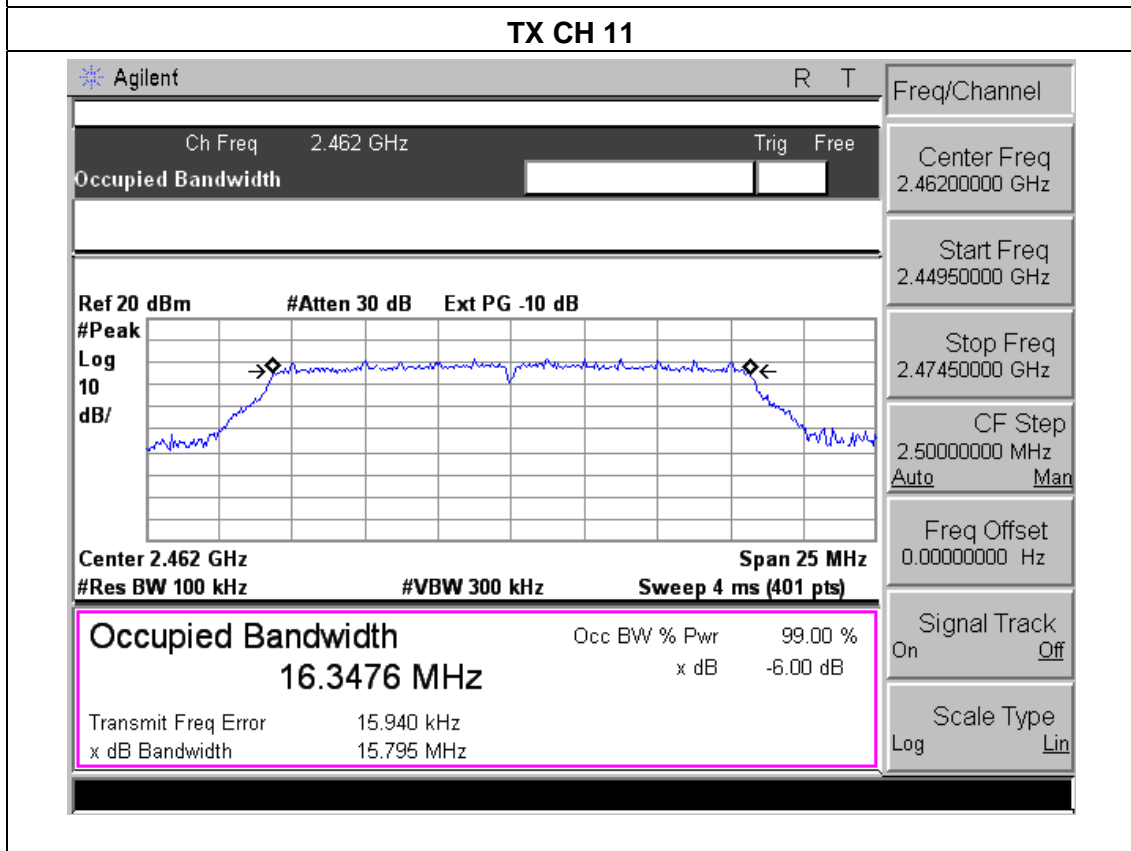
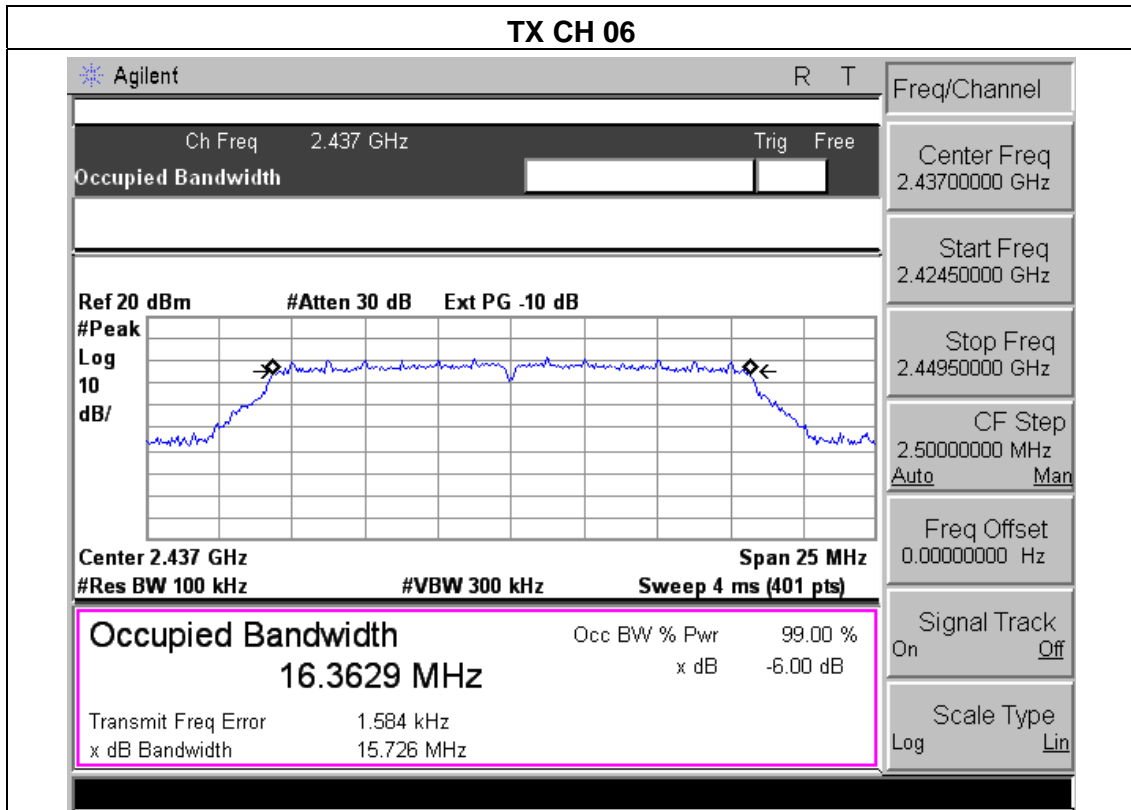

EUT :	Streaming wireless speaker	Model Name :	HK OMNI 20
Temperature :	25 °C	Relative Humidity :	56%
Pressure :	1012 hPa	Test Voltage :	AC 120V/60Hz
Test Mode :	TX n Mode(20M) /CH01, CH06, CH11-Ant A		

Channel	Frequency (MHz)	6dB bandwidth (MHz)	Limit (kHz)	Result
Low	2412	17.654	500	Pass
Middle	2437	17.651	500	Pass
High	2462	17.678	500	Pass

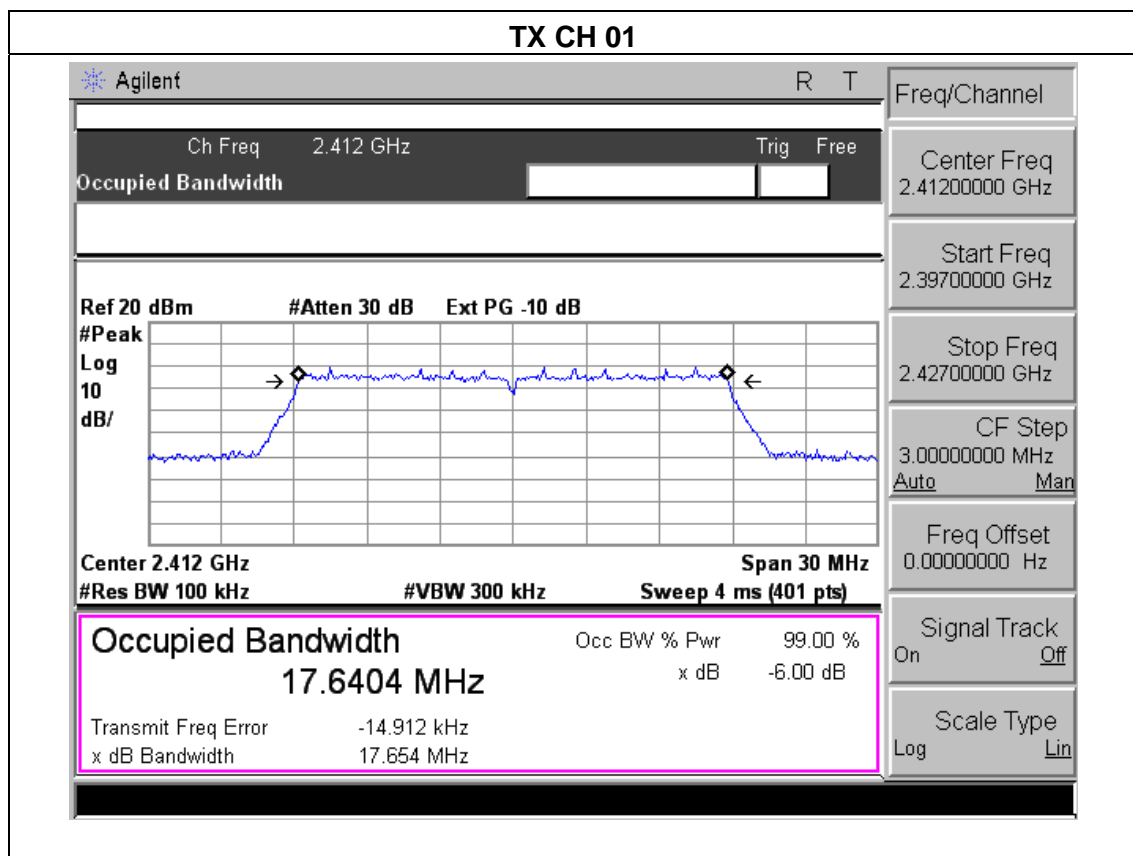

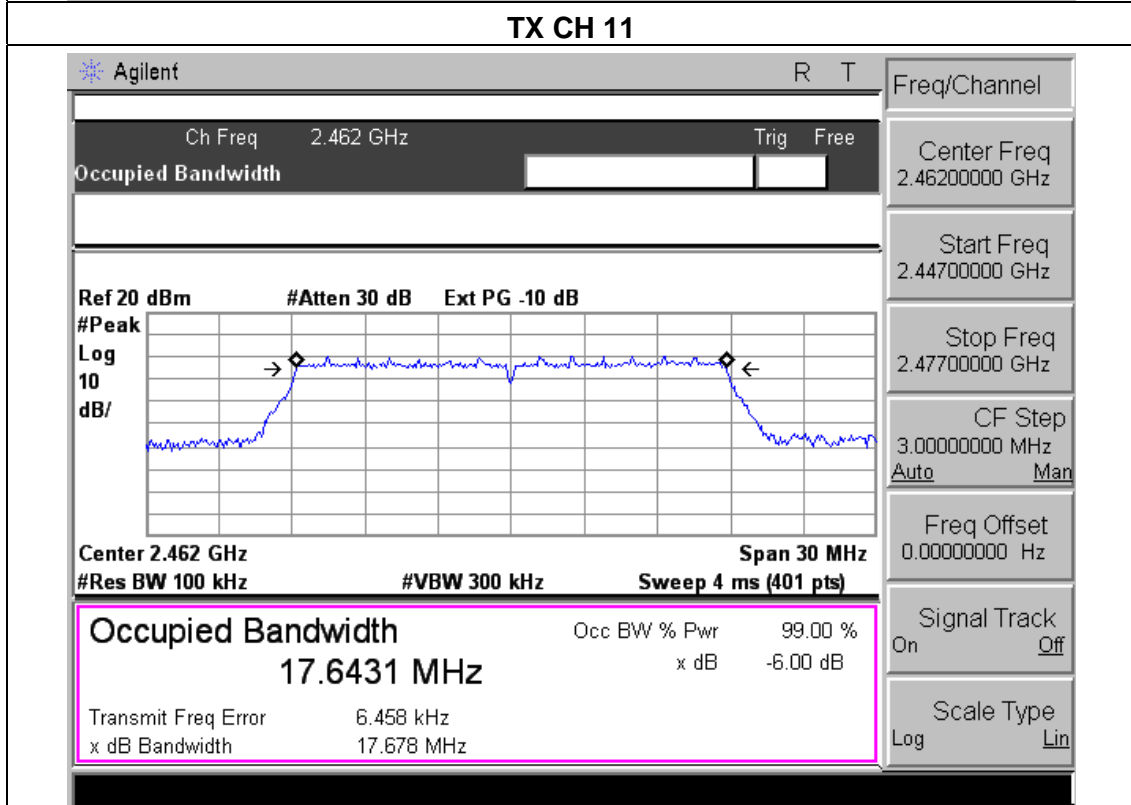
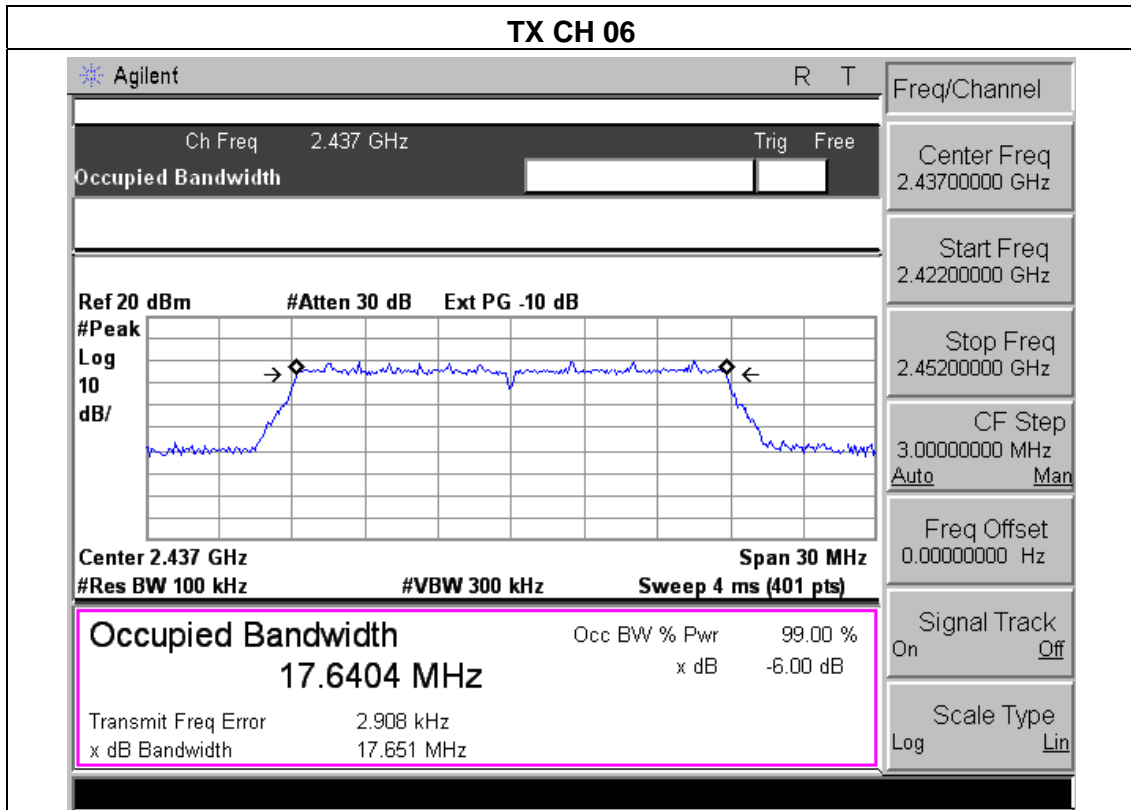

EUT :	Streaming wireless speaker	Model Name :	HK OMNI 20
Temperature :	25 °C	Relative Humidity :	56%
Pressure :	1012 hPa	Test Voltage :	AC 120V/60Hz
Test Mode :	TX b Mode /CH01, CH06, CH11-Ant B		

Channel	Frequency (MHz)	6dB bandwidth (MHz)	Limit (kHz)	Result
Low	2412	10.119	500	Pass
Middle	2437	10.103	500	Pass
High	2462	10.133	500	Pass

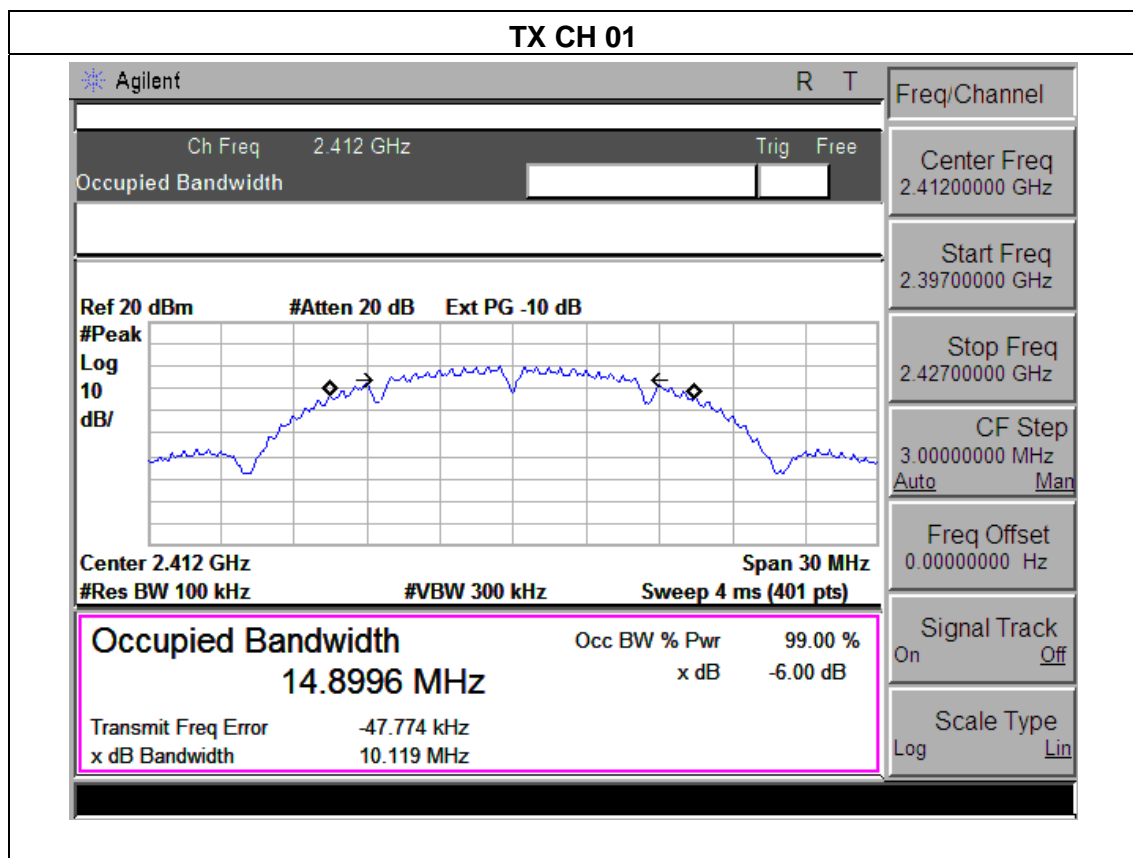

TX CH 06

Agilent		R	T	Freq/Channel	
Ch Freq 2.437 GHz		Trig Free		Center Freq 2.43700000 GHz	
Occupied Bandwidth				Start Freq 2.42200000 GHz	
Ref 20 dBm #Atten 20 dB Ext PG -10 dB				Stop Freq 2.45200000 GHz	
				CF Step 3.00000000 MHz Auto Man	
Center 2.437 GHz		Span 30 MHz		Freq Offset 0.00000000 Hz	
#Res BW 100 kHz		#VBW 300 kHz		Sweep 4 ms (401 pts)	
Occupied Bandwidth 14.8735 MHz		Occ BW % Pwr 99.00 % x dB -6.00 dB		Signal Track On Off	
Transmit Freq Error -59.397 kHz				Scale Type Log Lin	
x dB Bandwidth 10.103 MHz					

TX CH 11

Agilent		R	T	Freq/Channel	
Ch Freq 2.462 GHz		Trig Free		Center Freq 2.46200000 GHz	
Occupied Bandwidth				Start Freq 2.44700000 GHz	
Ref 20 dBm #Atten 20 dB Ext PG -10 dB				Stop Freq 2.47700000 GHz	
				CF Step 3.00000000 MHz Auto Man	
Center 2.462 GHz		Span 30 MHz		Freq Offset 0.00000000 Hz	
#Res BW 100 kHz		#VBW 300 kHz		Sweep 4 ms (401 pts)	
Occupied Bandwidth 14.8495 MHz		Occ BW % Pwr 99.00 % x dB -6.00 dB		Signal Track On Off	
Transmit Freq Error -78.843 kHz				Scale Type Log Lin	
x dB Bandwidth 10.133 MHz					

EUT :	Streaming wireless speaker	Model Name :	HK OMNI 20
Temperature :	25 °C	Relative Humidity :	60%
Pressure :	1012 hPa	Test Voltage :	AC 120V/60Hz
Test Mode :	TX g Mode /CH01, CH06, CH11-Ant B		

Channel	Frequency (MHz)	6dB bandwidth (MHz)	Limit (kHz)	Result
Low	2412	16.495	500	Pass
Middle	2437	16.517	500	Pass
High	2462	16.495	500	Pass

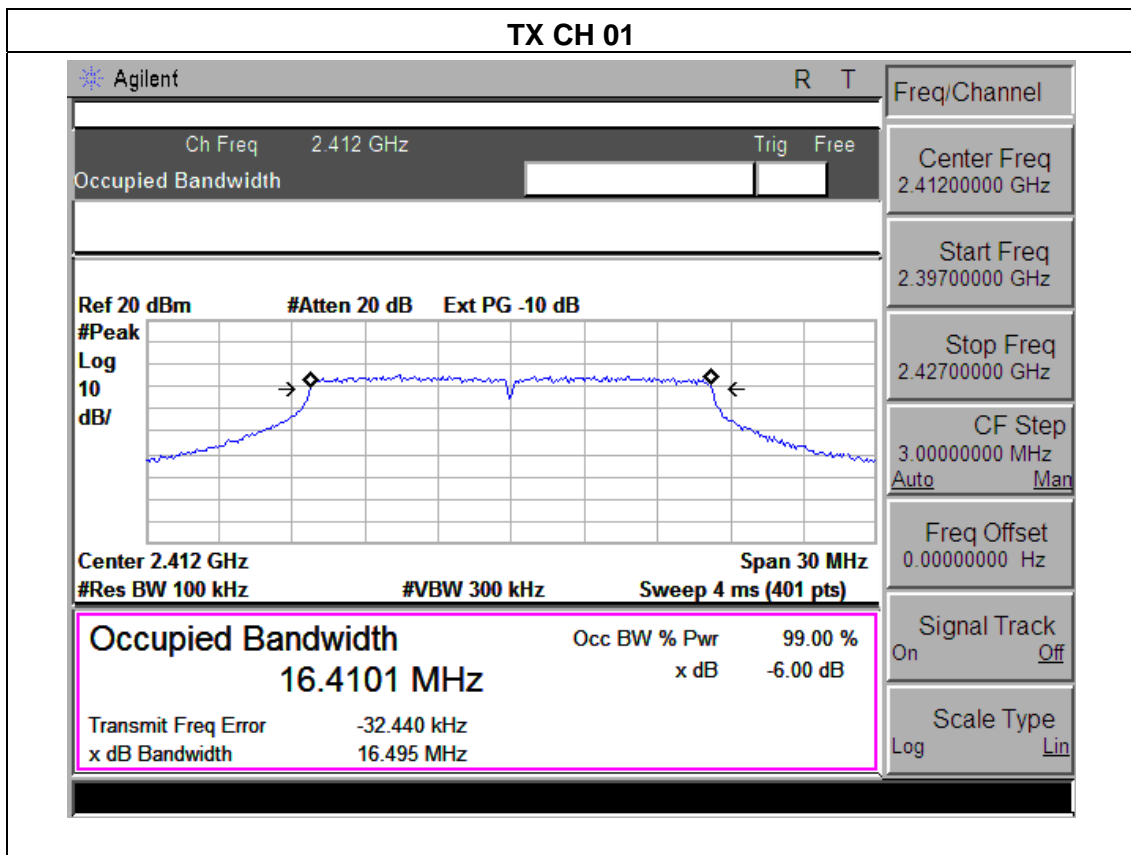

TX CH 06

Agilent R T

Ch Freq 2.437 GHz Trig Free

Occupied Bandwidth [] []

Ref 20 dBm #Atten 20 dB Ext PG -10 dB

#Peak
Log
10
dB/

Center 2.437 GHz Span 30 MHz

#Res BW 100 kHz #VBW 300 kHz Sweep 4 ms (401 pts)

Occupied Bandwidth	Occ BW % Pwr	99.00 %
16.4266 MHz	x dB	-6.00 dB
Transmit Freq Error	-43.927 kHz	
x dB Bandwidth	16.517 MHz	

Freq/Channel

Center Freq
2.43700000 GHz

Start Freq
2.42200000 GHz

Stop Freq
2.45200000 GHz

CF Step
3.00000000 MHz
Auto Man

Freq Offset
0.00000000 Hz

Signal Track
On Off

Scale Type
Log Lin

TX CH 11

Agilent R T

Ch Freq 2.462 GHz Trig Free

Occupied Bandwidth [] []

Ref 20 dBm #Atten 20 dB Ext PG -10 dB

#Peak
Log
10
dB/

Center 2.462 GHz Span 30 MHz

#Res BW 100 kHz #VBW 300 kHz Sweep 4 ms (401 pts)

Occupied Bandwidth	Occ BW % Pwr	99.00 %
16.4196 MHz	x dB	-6.00 dB
Transmit Freq Error	-40.520 kHz	
x dB Bandwidth	16.495 MHz	

Freq/Channel

Center Freq
2.46200000 GHz

Start Freq
2.44700000 GHz

Stop Freq
2.47700000 GHz

CF Step
3.00000000 MHz
Auto Man

Freq Offset
0.00000000 Hz

Signal Track
On Off

Scale Type
Log Lin

EUT :	Streaming wireless speaker	Model Name :	HK OMNI 20
Temperature :	25 °C	Relative Humidity :	56%
Pressure :	1012 hPa	Test Voltage :	AC 120V/60Hz
Test Mode :	TX n Mode(20M) /CH01, CH06, CH11-Ant B		

Channel	Frequency (MHz)	6dB bandwidth (MHz)	Limit (kHz)	Result
Low	2412	17.715	500	Pass
Middle	2437	17.717	500	Pass
High	2462	17.701	500	Pass

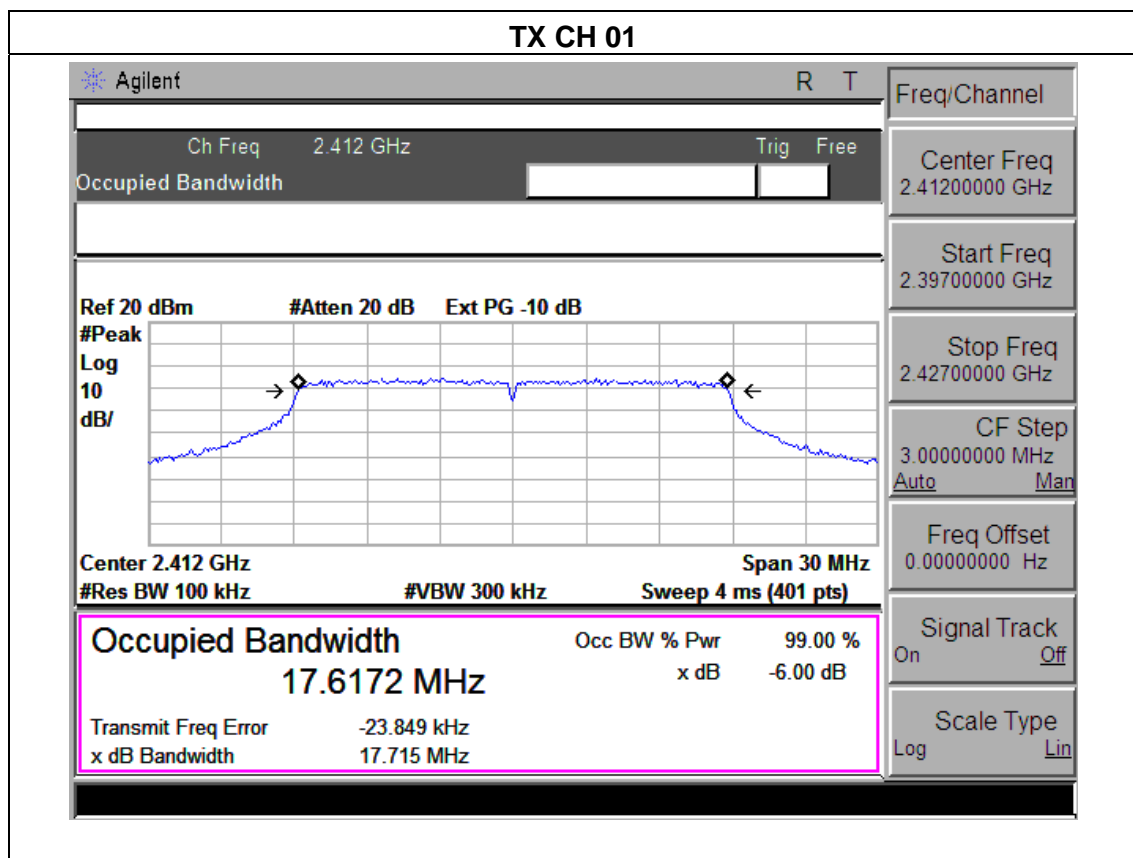

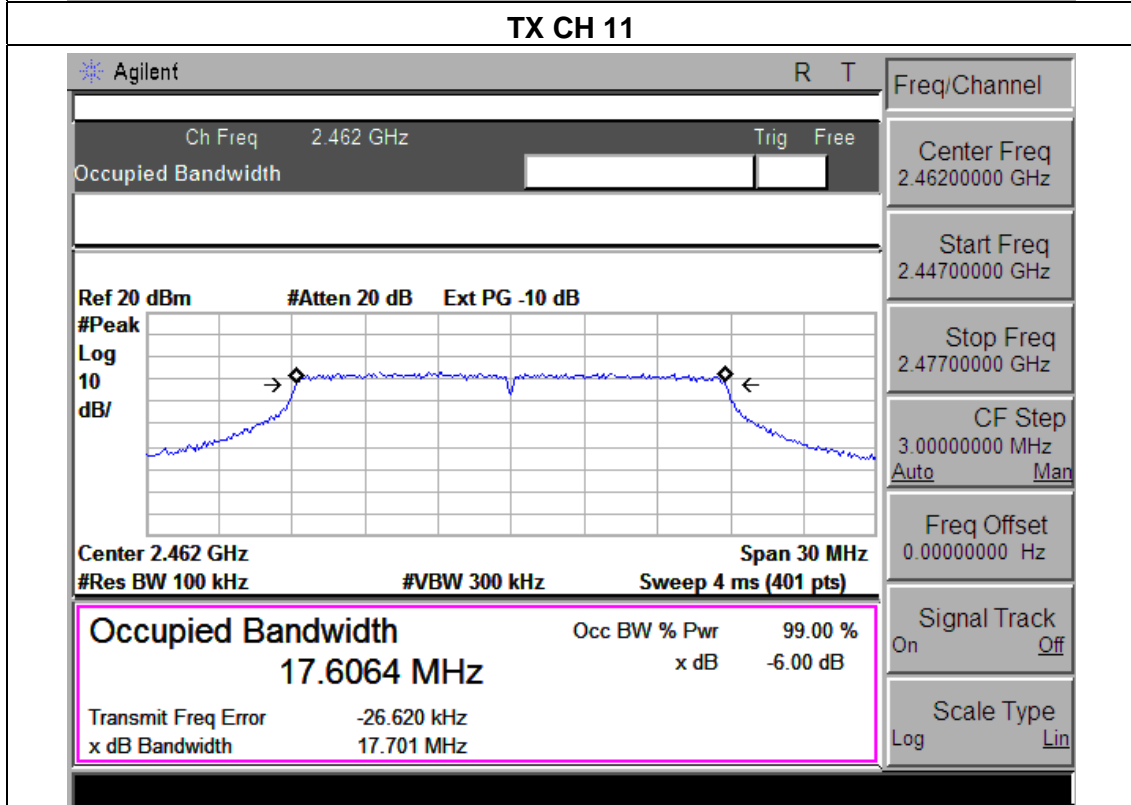
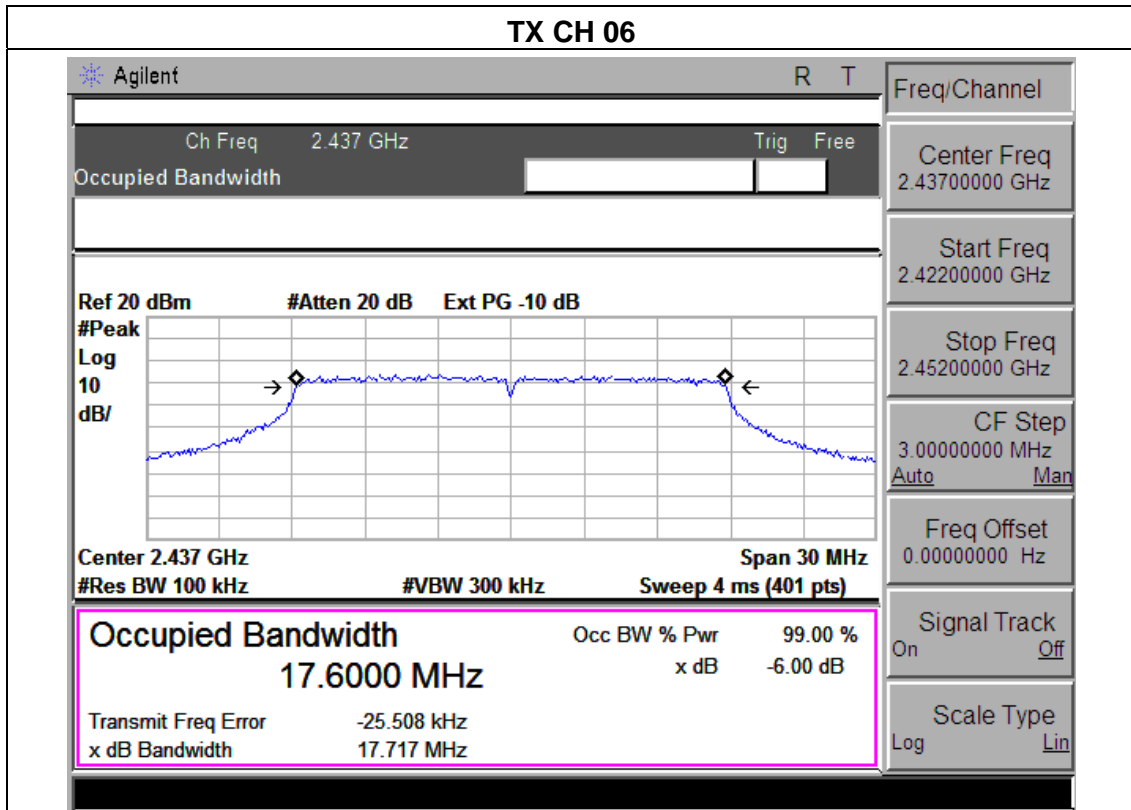

6. PEAK OUTPUT POWER TEST

6.1 APPLIED PROCEDURES / LIMIT

FCC Part15 (15.247) , Subpart C				
Section	Test Item	Limit	Frequency Range (MHz)	Result
15.247(b)(3)	Peak Output Power	1 watt	2400-2483.5	PASS

6.1.1 TEST PROCEDURE

- a. The EUT was directly connected to the Power meter

6.1.2 DEVIATION FROM STANDARD

No deviation.

6.1.3 TEST SETUP



6.1.4 EUT OPERATION CONDITIONS

The EUT tested system was configured as the statements of 2.4 Unless otherwise a special operating condition is specified in the follows during the testing.

6.1.5 TEST RESULTS

EUT :	Streaming wireless speaker	Model Name :	HK OMNI 20
Temperature :	25 °C	Relative Humidity :	60%
Pressure :	1012 hPa	Test Voltage :	AC 120V/60Hz
Test Mode :	TX b/g/n Mode-Ant A		

TX 802.11b Mode				
Test Channel	Frequency	Maximum Conducted Output Power(PK)	Maximum Conducted Output Power(AV)	LIMIT
	(MHz)	(dBm)	(dBm)	(dBm)
CH01	2412	12.11	9.04	30
CH06	2437	12.22	9.21	30
CH11	2462	12.32	9.22	30
TX 802.11g Mode				
CH01	2412	11.34	8.64	30
CH06	2437	11.42	8.42	30
CH11	2462	11.12	8.31	30
TX 802.11n-HT20 Mode				
CH01	2412	10.42	8.51	30
CH06	2437	10.51	8.57	30
CH11	2462	10.32	8.25	30

EUT :	Streaming wireless speaker	Model Name :	HK OMNI 20
Temperature :	25 °C	Relative Humidity :	60%
Pressure :	1012 hPa	Test Voltage :	AC 120V/60Hz
Test Mode :	TX b/g/n Mode-Ant B		

TX 802.11b Mode				
Test Channel	Frequency	Maximum Conducted Output Power(PK)	Maximum Conducted Output Power(AV)	LIMIT
	(MHz)	(dBm)	(dBm)	(dBm)
CH01	2412	12.53	9.32	30
CH06	2437	12.52	9.23	30
CH11	2462	12.22	9.48	30
TX 802.11g Mode				
CH01	2412	11.31	8.67	30
CH06	2437	11.42	8.41	30
CH11	2462	11.14	8.35	30
TX 802.11n-HT20 Mode				
CH01	2412	10.41	8.58	30
CH06	2437	10.62	8.65	30
CH11	2462	10.53	8.32	30

7. 100 KHZ BANDWIDTH OF FREQUENCY BAND EDGE

APPLICABLE STANDARD

In any 100 kHz bandwidth outside the frequency band in which the spread spectrum or digitally modulated intentional radiator is operating, the radio frequency power that is produced by the intentional radiator shall be at least 20 dB below that in the 100 kHz bandwidth within the band that contains the highest level of the desired power, based on either an RF conducted or a radiated measurement, provided the transmitter demonstrates compliance with the peak conducted power limits. If the transmitter complies with the conducted power limits based on the use of RMS averaging over a time interval, as permitted under paragraph (b)(3) of this section, the attenuation required under this paragraph shall be 30 dB instead of 20 dB. Attenuation below the general limits specified in §15.209(a) is not required. In addition, radiated emissions which fall in the restricted bands, as defined in §15.205(a), must also comply with the radiated emission limits specified in §15.209(a) (see §15.205(c)).

TEST PROCEDURE

- a) Check the calibration of the measuring instrument using either an internal calibrator or a known signal from an external generator.
- b) Position the EUT without connection to measurement instrument. Turn on the EUT and connect its antenna terminal to measurement instrument via a low loss cable. Then set it to any one measured frequency within its operating range, and make sure the instrument is operated in its linear range.
- c) Set RBW to 100 kHz and VBW of spectrum analyzer to 300 kHz with a convenient frequency span including 100 kHz bandwidth from band edge.
- d) Measure the highest amplitude appearing on spectral display and set it as a reference level. Plot the graph with marking the highest point and edge frequency.
- e) Repeat above procedures until all measured frequencies were complete.

7.1 DEVIATION FROM STANDARD

No deviation.

7.2 TEST SETUP

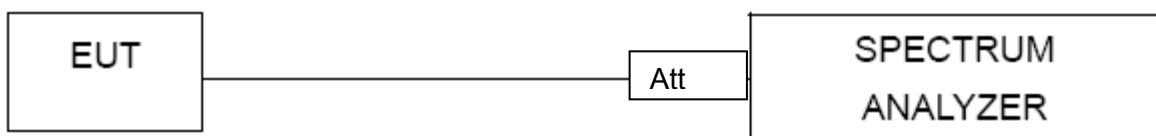

7.3 EUT OPERATION CONDITIONS

The EUT tested system was configured as the statements of 2.4 Unless otherwise a special operating condition is specified in the follows during the testing.

7.4 TEST RESULTS

EUT :	Streaming wireless speaker	Model Name :	HK OMNI 20
Temperature :	25 °C	Relative Humidity :	56%
Pressure :	1012 hPa	Test Voltage :	AC 120V/60Hz
Test Mode :	Ant A		

Frequency Band	Delta Peak to band emission (dBc)	> Limit (dBc)	Result
802.11b mode			
Left-band	51.52	20	Pass
Right-band	50.71	20	Pass
802.11g mode			
Left-band	35.64	20	Pass
Right-band	37.22	20	Pass
802.11n-HT20 mode			
Left-band	37.07	20	Pass
Right-band	37.13	20	Pass

Radiated band edge:

Frequency (MHz)	Meter Reading (dBμV)	Factor (dB)	Emission Level (dBμV/m)	Limits (dBμV/m)	Margin (dB)	Detector Type	Comment
802.11b							
2390	44.54	-13.06	31.48	74	-42.52	peak	Vertical
2390	46.74	-13.06	33.68	74	-40.32	peak	Horizontal
2483.5	47.11	-12.78	34.33	74	-39.67	peak	Vertical
2483.5	45.11	-12.78	32.33	74	-41.67	peak	Horizontal
802.11g							
2390	45.64	-13.06	32.58	74	-41.42	peak	Vertical
2390	47.18	-13.06	34.12	74	-39.88	peak	Horizontal
2483.5	48.32	-12.78	35.54	74	-38.46	peak	Vertical
2483.5	46.59	-12.78	33.81	74	-40.19	peak	Horizontal
802.11n (20)							
2390	44.03	-13.06	30.97	74	-43.03	peak	Vertical
2390	46.54	-13.06	33.48	74	-40.52	peak	Horizontal
2483.5	49.11	-12.78	36.33	74	-37.67	peak	Vertical
2483.5	47.15	-12.78	34.37	74	-39.63	peak	Horizontal

Note: Test method to see chapter 3.2 . When PK value is lower than the Average value limit, average not record.

EUT :	Streaming wireless speaker	Model Name :	HK OMNI 20
Temperature :	25 °C	Relative Humidity :	56%
Pressure :	1012 hPa	Test Voltage :	AC 120V/60Hz
Test Mode :	Ant B		

Frequency Band	Delta Peak to band emission (dBc)	> Limit (dBc)	Result
802.11b			
Left-band	37.25	20	Pass
Right-band	53.58	20	Pass
802.11g			
Left-band	29.80	20	Pass
Right-band	46.12	20	Pass
802.11n20			
Left-band	30.24	20	Pass
Right-band	45.37	20	Pass

Radiated band edge:

Frequency (MHz)	Meter Reading (dBμV)	Factor (dB)	Emission Level (dBμV/m)	Limits (dBμV/m)	Margin (dB)	Detector Type	Comment
802.11b							
2390	57.46	-13.06	44.40	74	-29.60	peak	Vertical
2390	58.33	-13.06	45.27	74	-28.73	peak	Horizontal
2483.5	58.15	-12.78	45.37	74	-28.63	peak	Vertical
2483.5	57.43	-12.78	44.65	74	-29.35	peak	Horizontal
802.11g							
2390	59.47	-13.06	46.41	74	-27.59	peak	Vertical
2390	58.63	-13.06	45.57	74	-28.43	peak	Horizontal
2483.5	58.64	-12.78	45.86	74	-28.14	peak	Vertical
2483.5	59.47	-12.78	46.69	74	-27.31	peak	Horizontal
802.11n20							
2390	58.19	-13.06	45.13	74	-28.87	peak	Vertical
2390	58.75	-13.06	45.69	74	-28.31	peak	Horizontal
2483.5	57.56	-12.78	44.78	74	-29.22	peak	Vertical
2483.5	58.48	-12.78	45.70	74	-28.30	peak	Horizontal

Note: Test method to see chapter 3.2 . When PK value is lower than the Average value limit, average not record.

Ant A

802.11b: Band Edge, Left Side

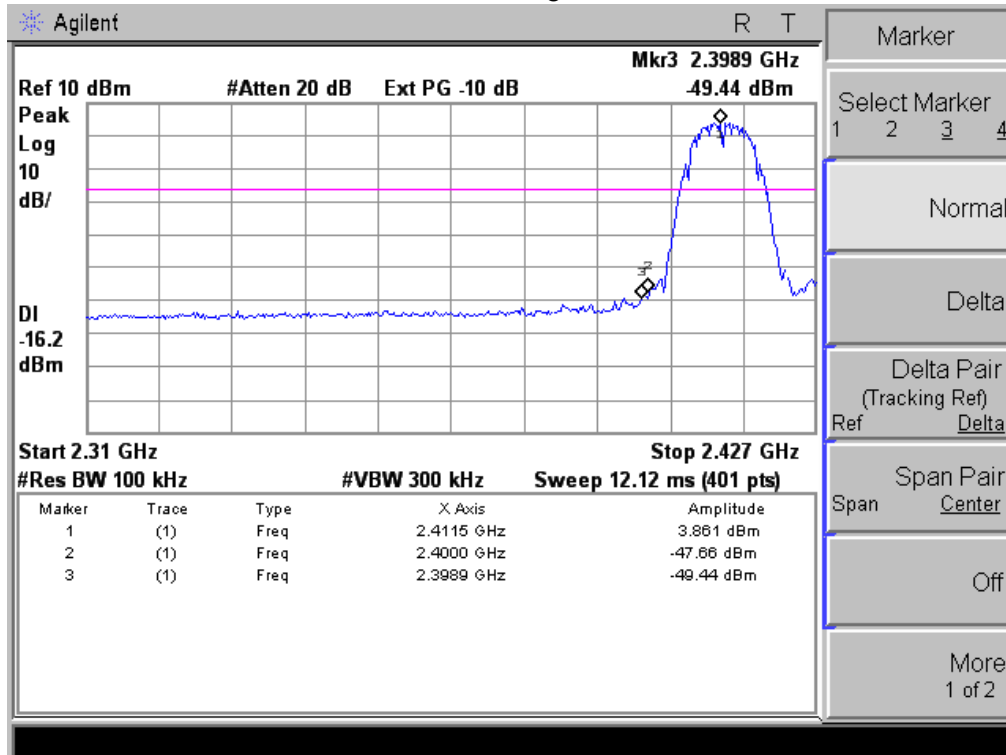

802.11b: Band Edge, Right Side

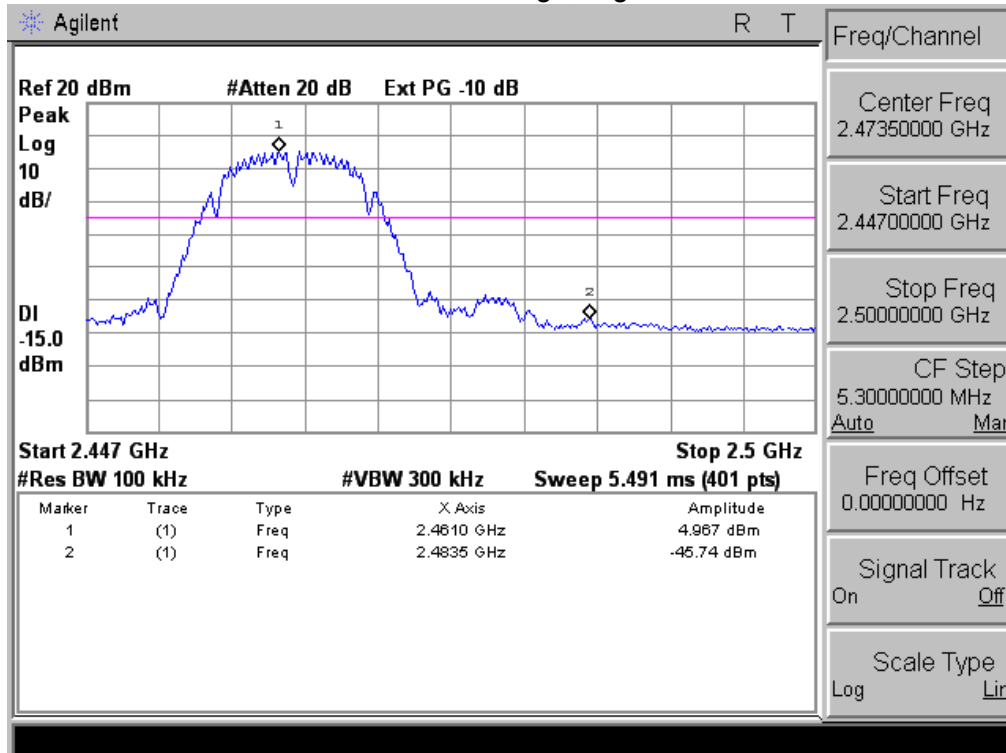

802.11g: Band Edge, Left Side

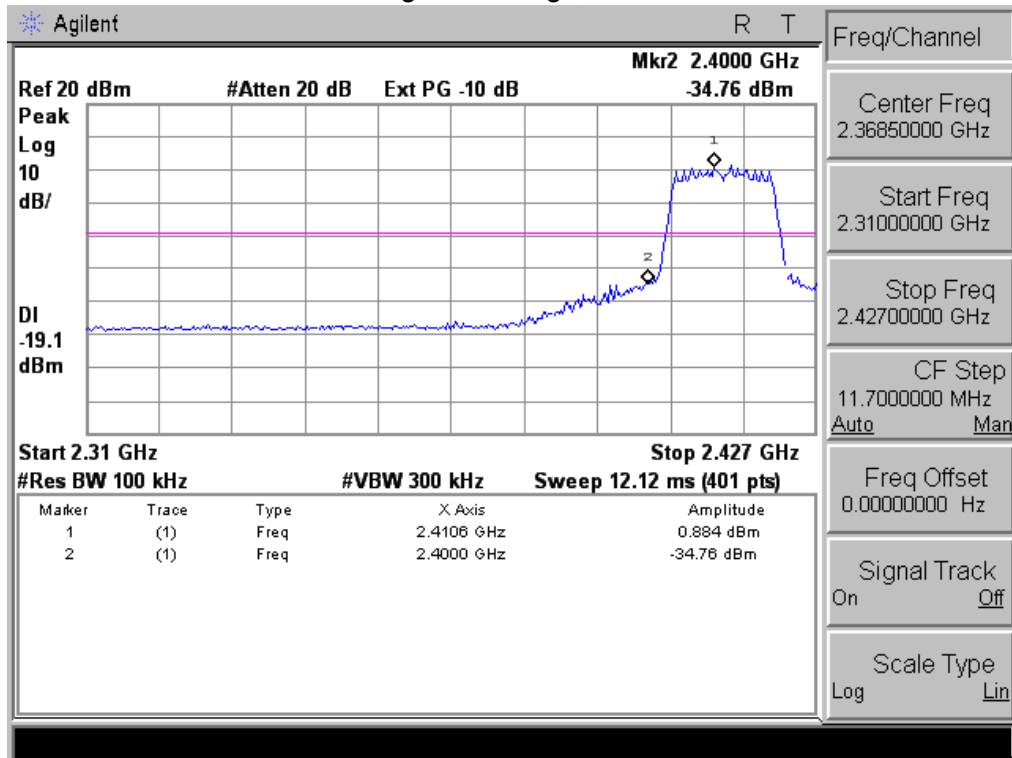

802.11g: Band Edge, Right Side

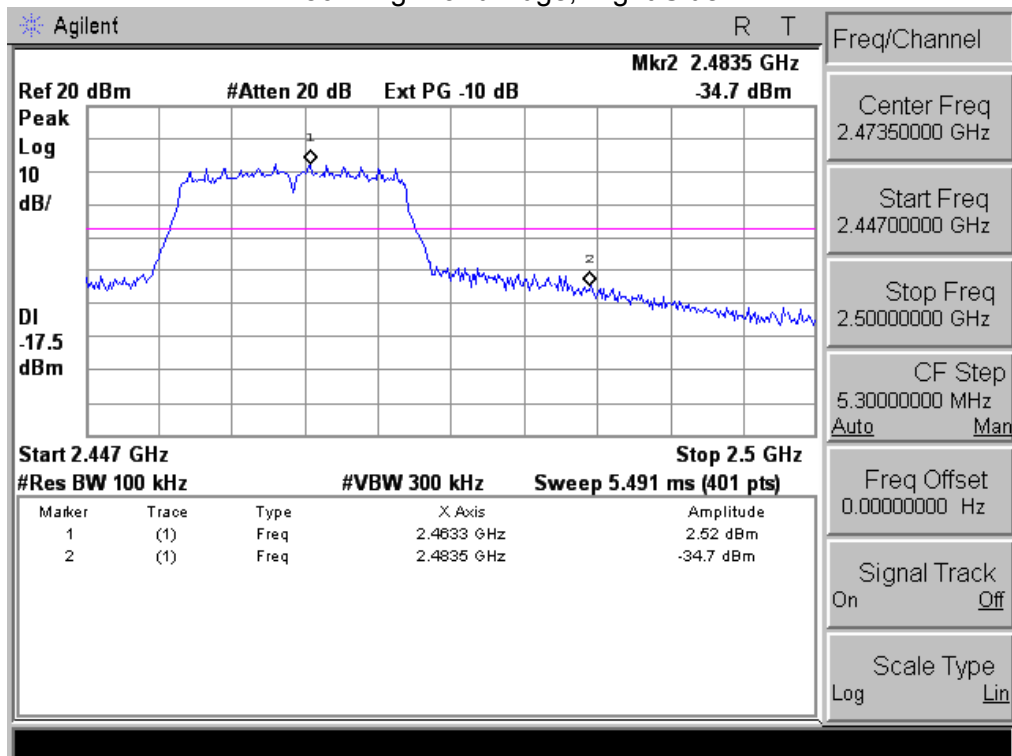

802.11n-HT20: Band Edge, Left Side

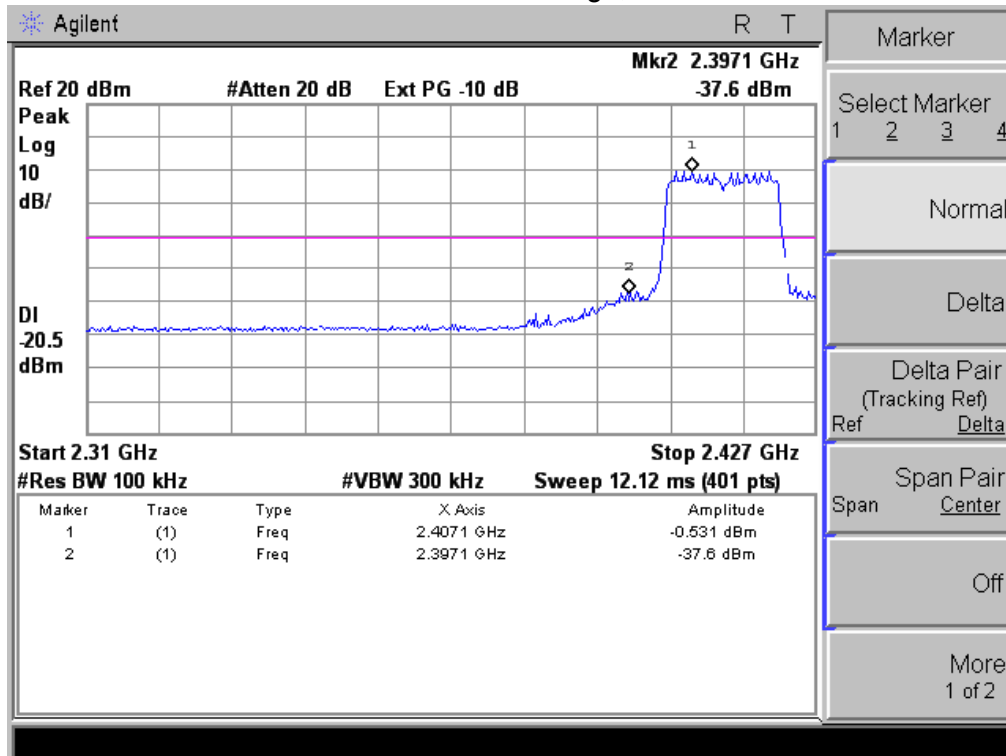

802.11n-HT20: Band Edge, Right Side

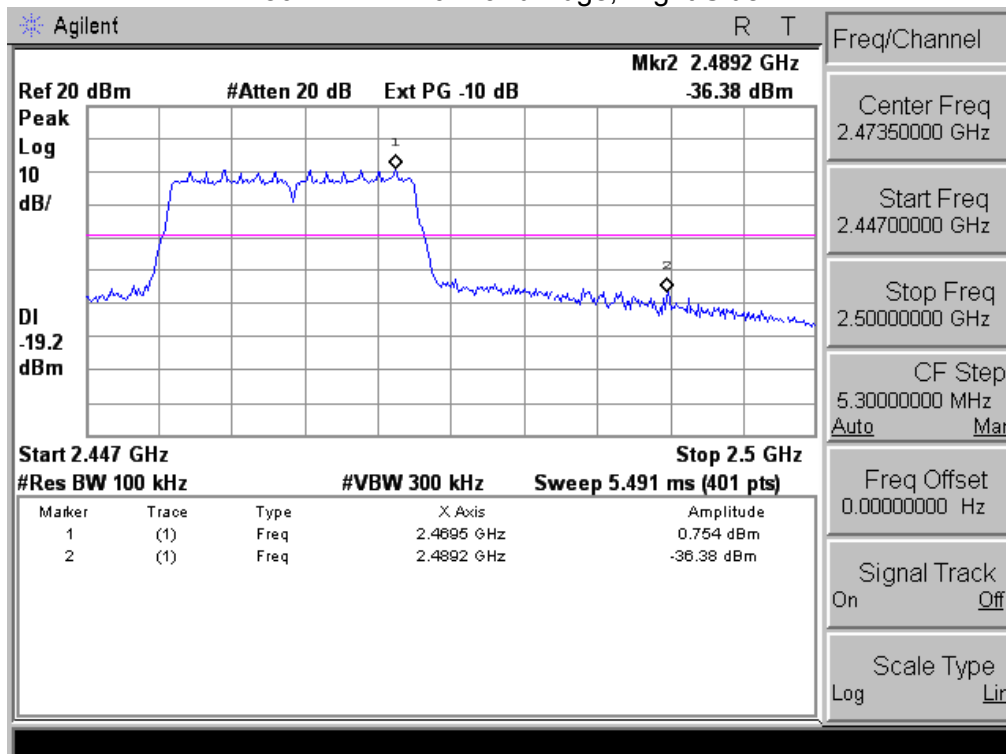

Ant B

802.11b: Band Edge, Left Side

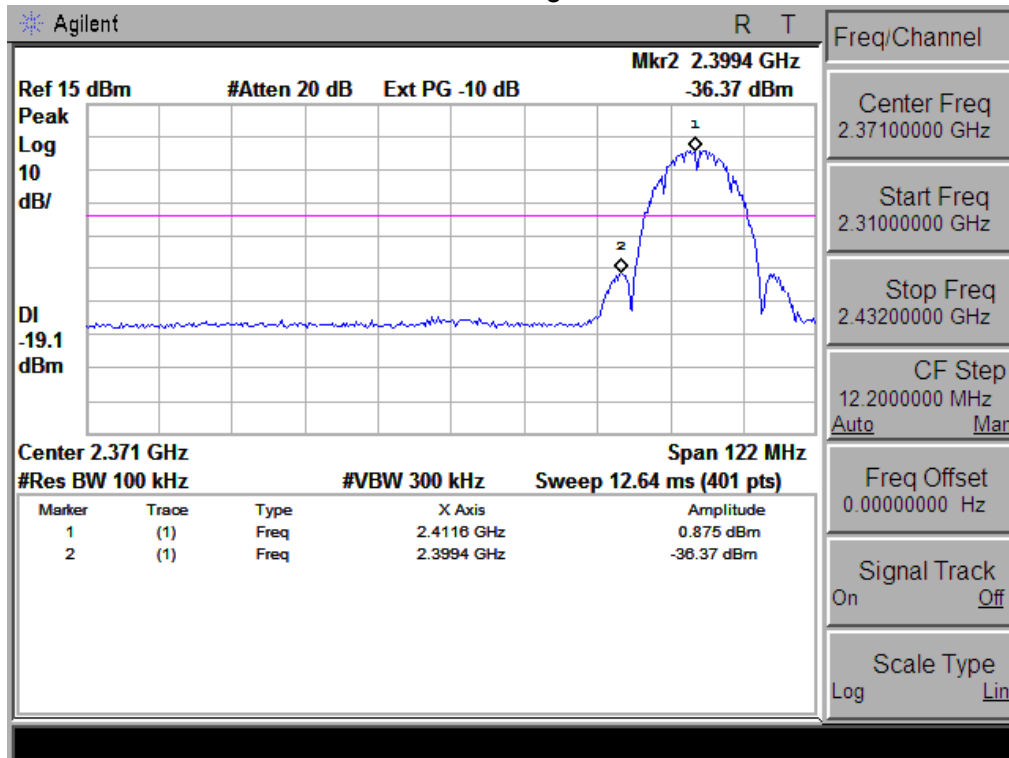

802.11b: Band Edge, Right Side

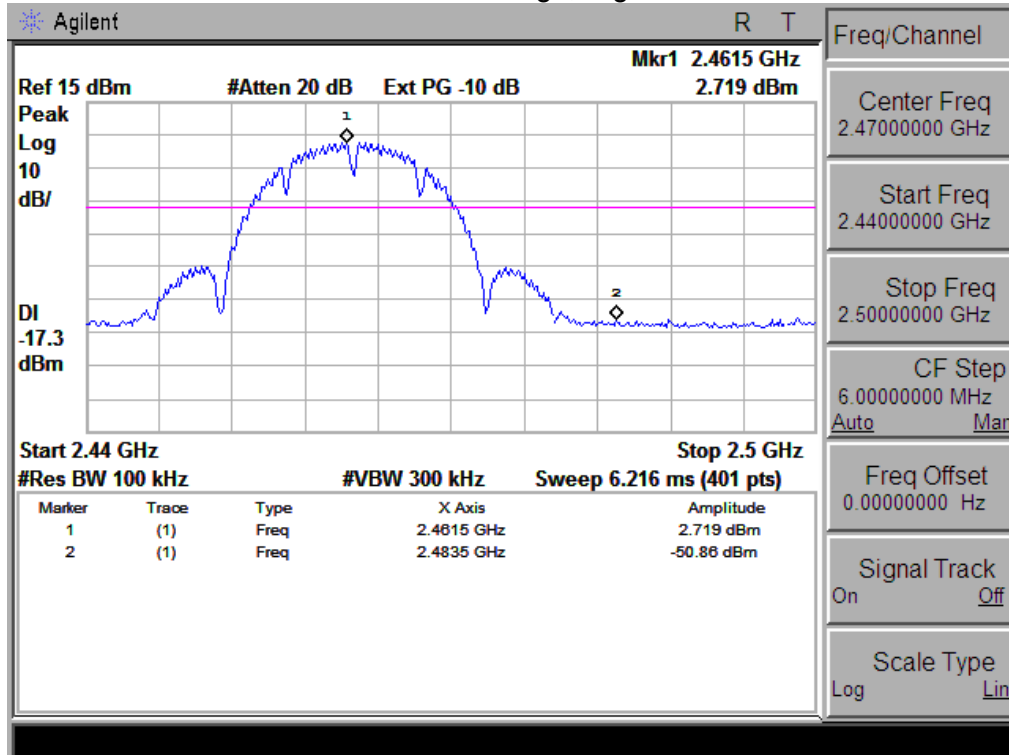

802.11g: Band Edge, Left Side

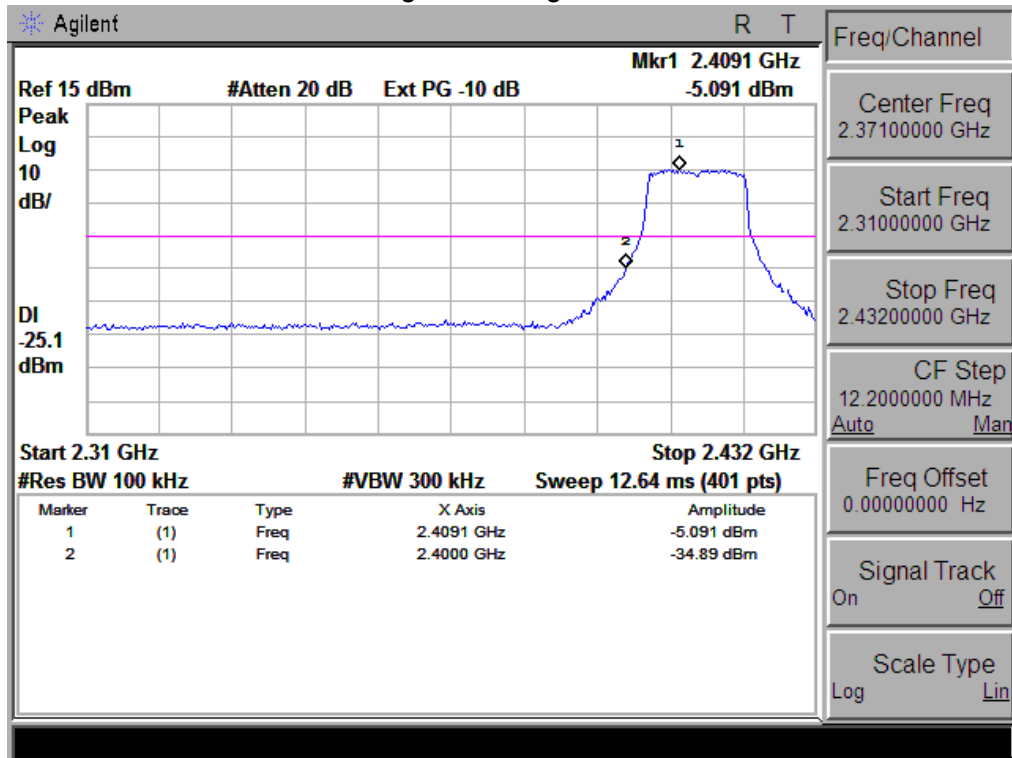

802.11g: Band Edge, Right Side

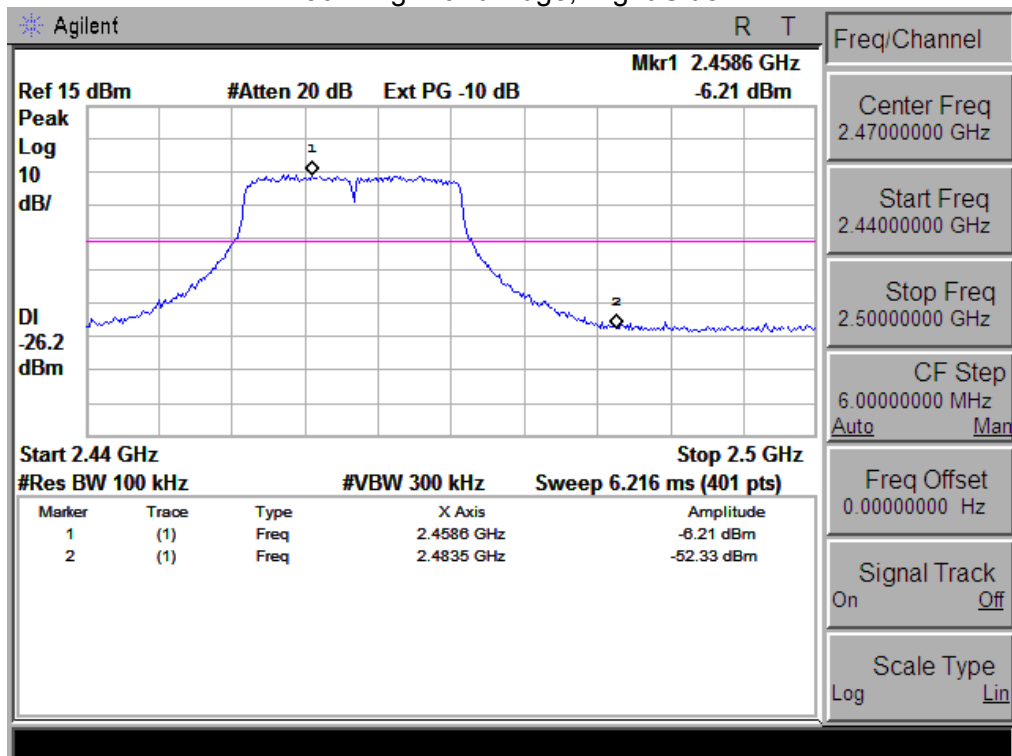

802.11n-HT20: Band Edge, Left Side

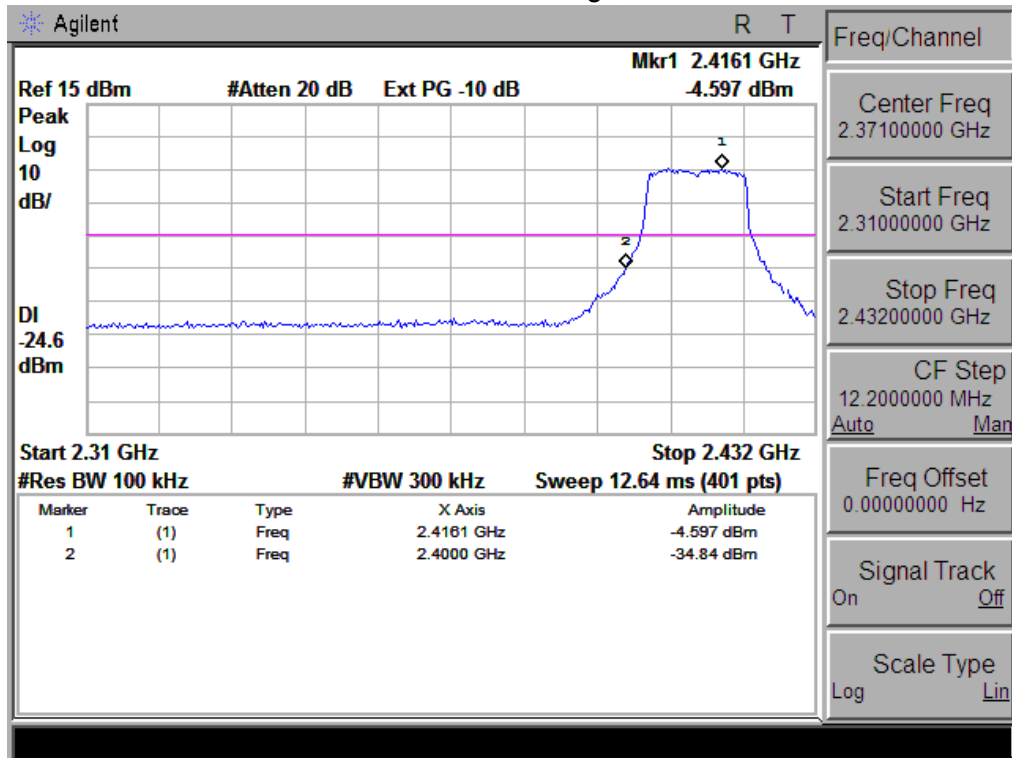

802.11n-HT20: Band Edge, Right Side

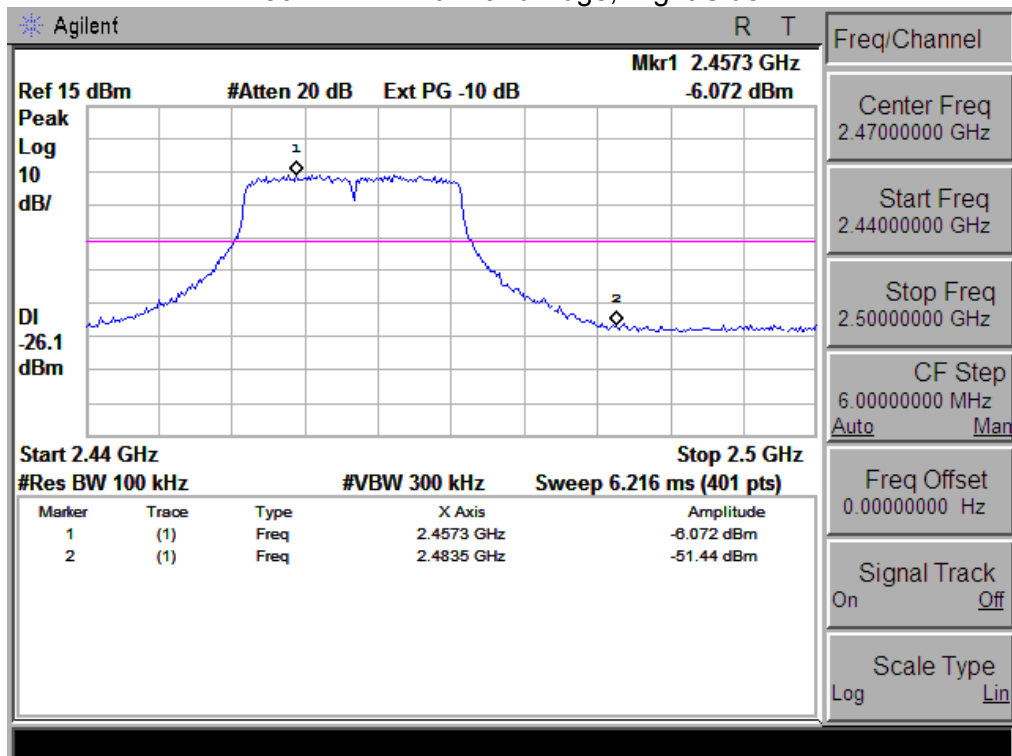

8. ANTENNA REQUIREMENT

8.1 STANDARD REQUIREMENT

15.203 requirement: For intentional device, according to 15.203: an intentional radiator shall be designed to ensure that no antenna other than that furnished by the responsible party shall be used with the device.

8.2 EUT ANTENNA

The EUT antenna is FPCB antenna. It comply with the standard requirement.