

### Occupied Bandwidth Measurement\_11N40SISO\_5270\_Ant1

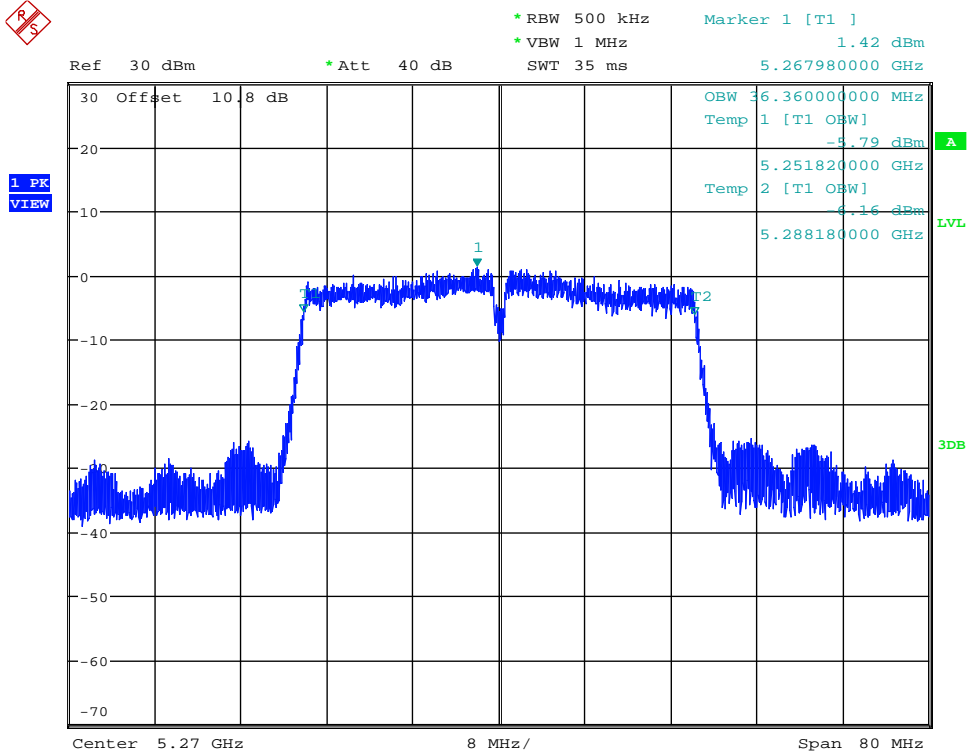

### Occupied Bandwidth Measurement\_11N40SISO\_5270\_Ant2

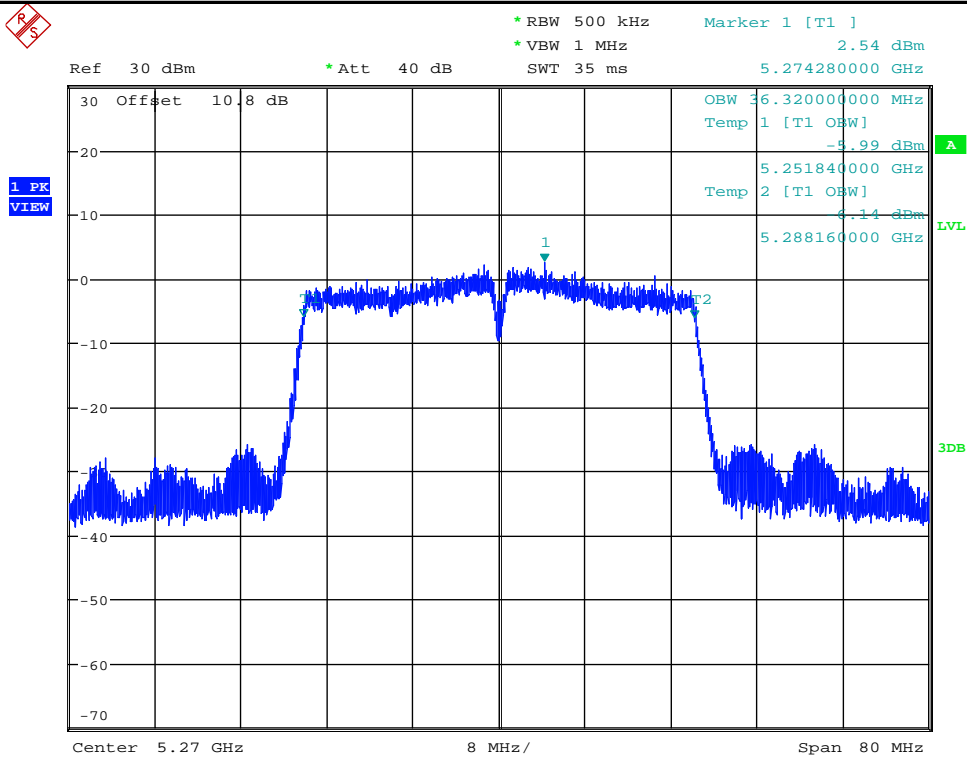

### Occupied Bandwidth Measurement\_11N40SISO\_5310\_Ant1



Ref 30 dBm      \* Att 40 dB      \* RBW 500 kHz      Marker 1 [T1 ]  
\* VBW 1 MHz      3.58 dBm  
SWT 35 ms      5.314160000 GHz

1 PK VIEW

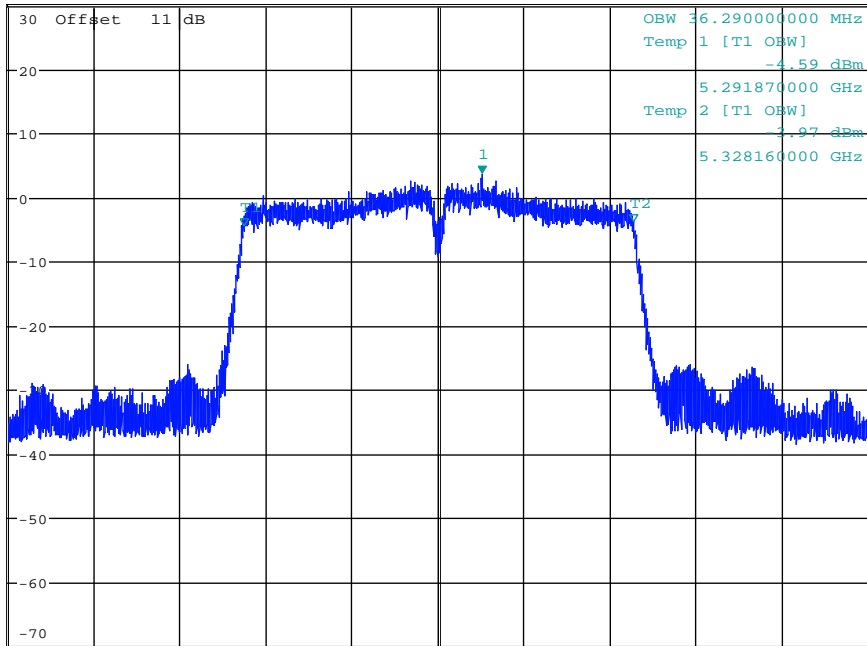

Center 5.31 GHz      8 MHz/      Span 80 MHz

Date: 28.DEC.2017 21:50:40

### Occupied Bandwidth Measurement\_11N40SISO\_5310\_Ant2



Ref 30 dBm      \* Att 40 dB      \* RBW 500 kHz      Marker 1 [T1 ]  
\* VBW 1 MHz      2.85 dBm  
SWT 35 ms      5.312290000 GHz

1 PK VIEW

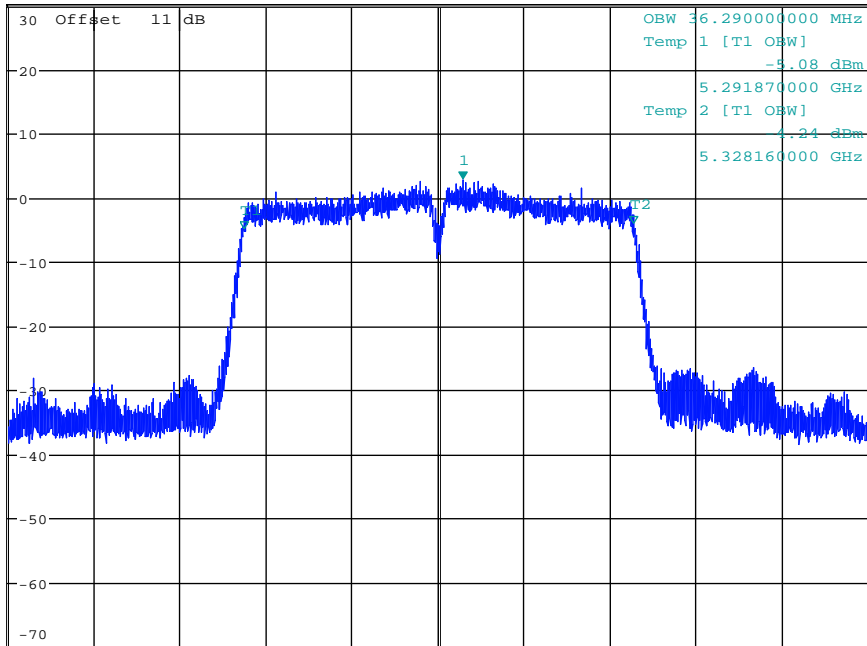

Center 5.31 GHz      8 MHz/      Span 80 MHz

Date: 3.JAN.2018 14:50:58

### Occupied Bandwidth Measurement\_11N40SISO\_5510\_Ant1

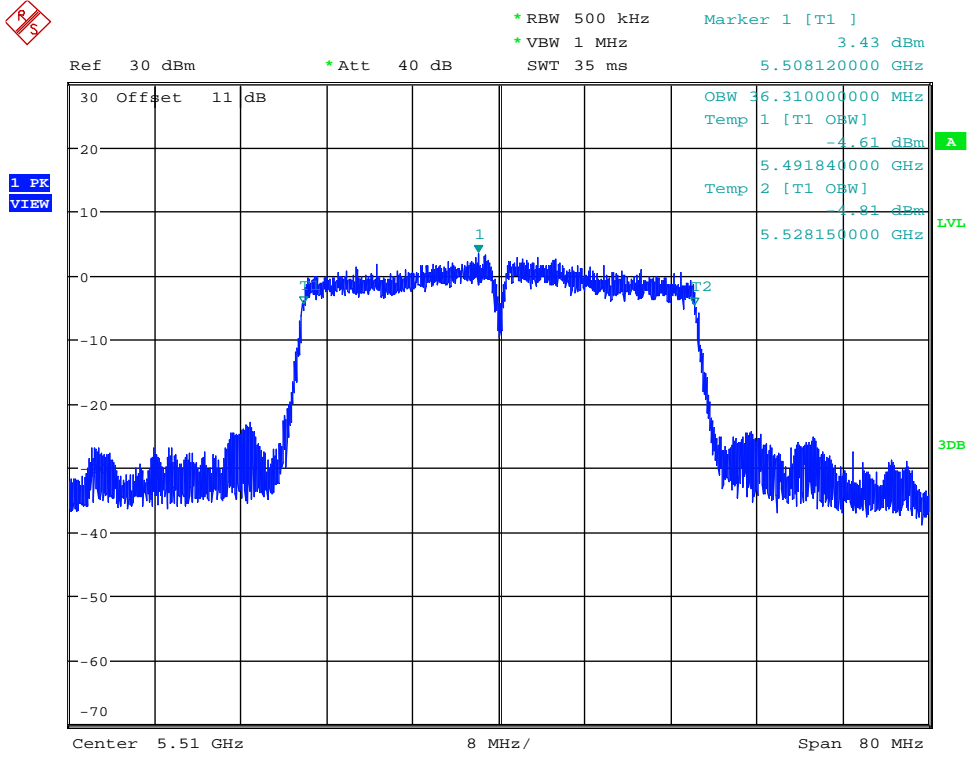

Date: 28.DEC.2017 21:56:29

### Occupied Bandwidth Measurement\_11N40SISO\_5510\_Ant2

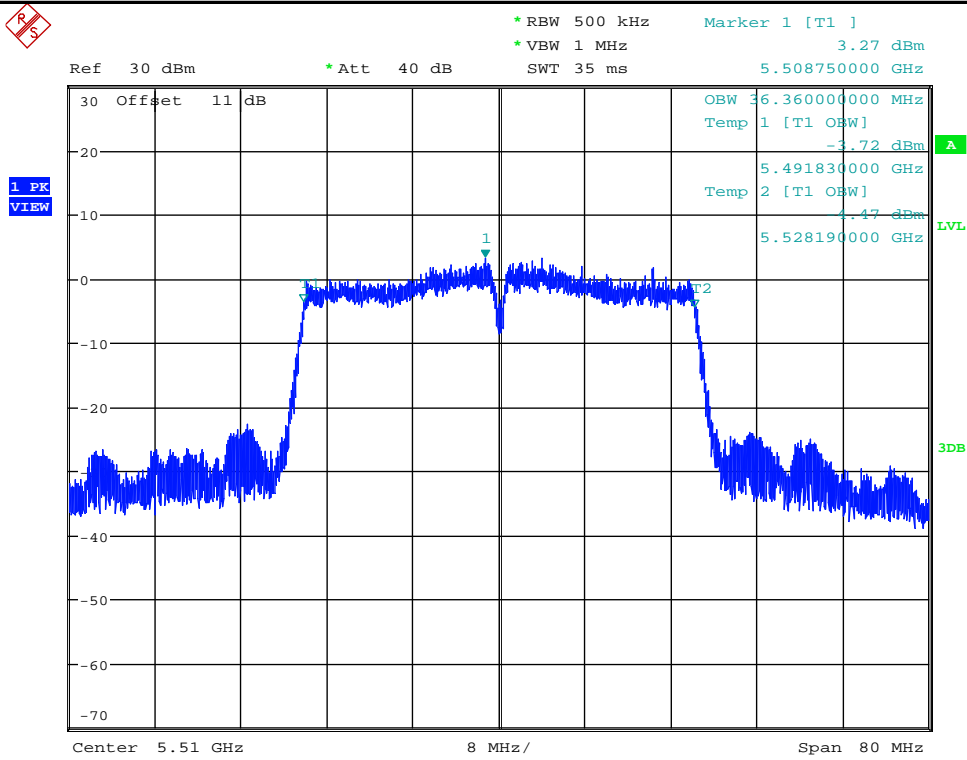

Date: 3.JAN.2018 14:55:53

### Occupied Bandwidth Measurement\_11N40SISO\_5550\_Ant1

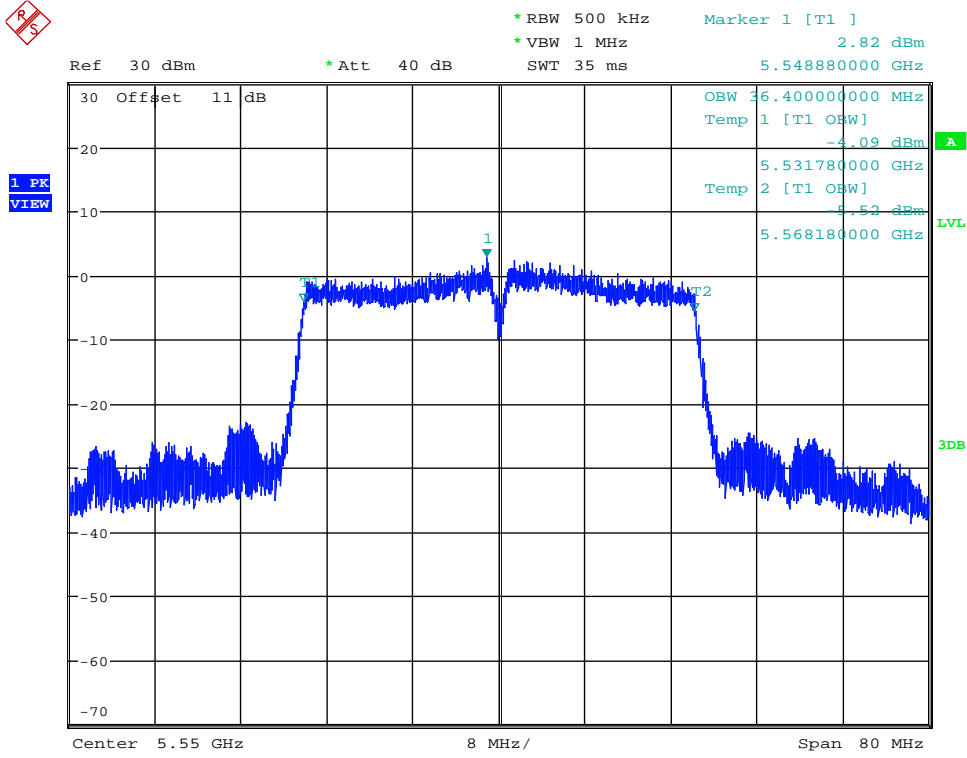

Date: 28.DEC.2017 22:01:12

### Occupied Bandwidth Measurement\_11N40SISO\_5550\_Ant2

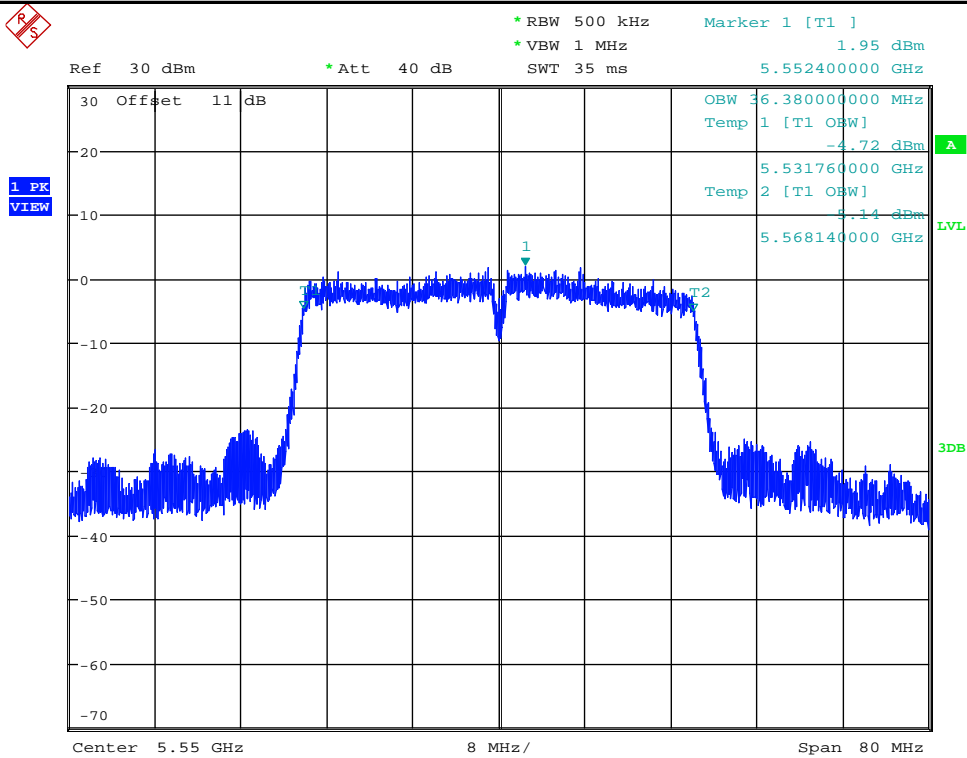

Date: 3.JAN.2018 15:01:48

### Occupied Bandwidth Measurement\_11N40SISO\_5670\_Ant1

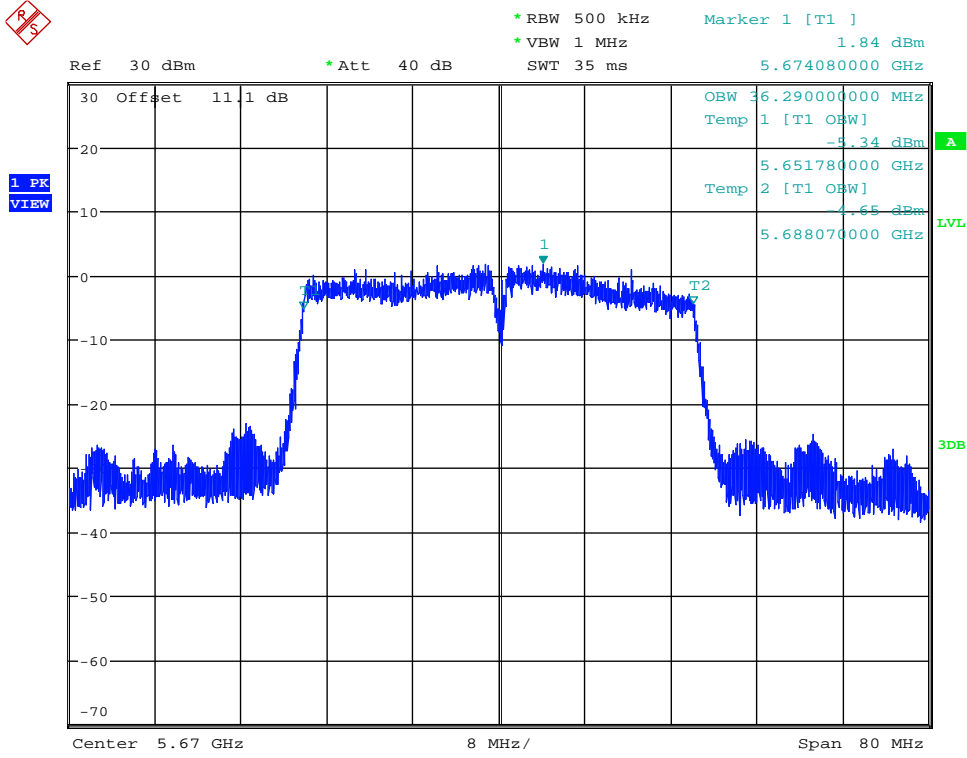

Date: 28.DEC.2017 22:06:50

### Occupied Bandwidth Measurement\_11N40SISO\_5670\_Ant2

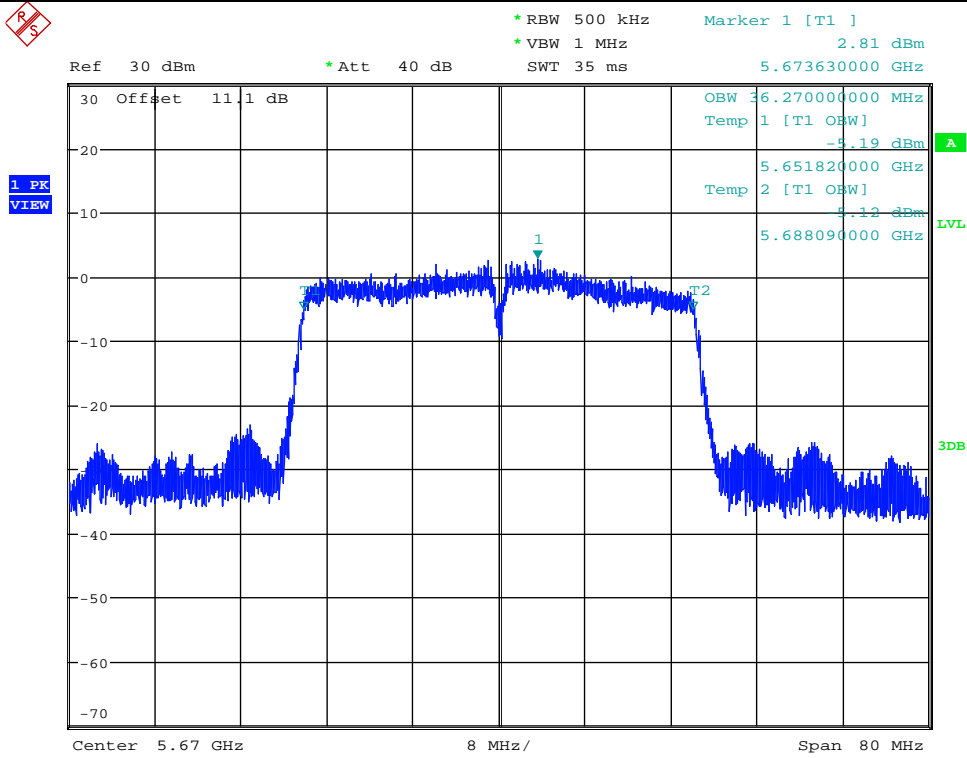

Date: 3.JAN.2018 15:05:54

### Occupied Bandwidth Measurement\_11N40SISO\_5755\_Ant1



Ref 30 dBm      \* Att 40 dB      \* RBW 100 kHz      Marker 1 [T1 ]  
\* VBW 300 kHz      -3.01 dBm  
SWT 35 ms      5.758780000 GHz

1 PK  
VIEW

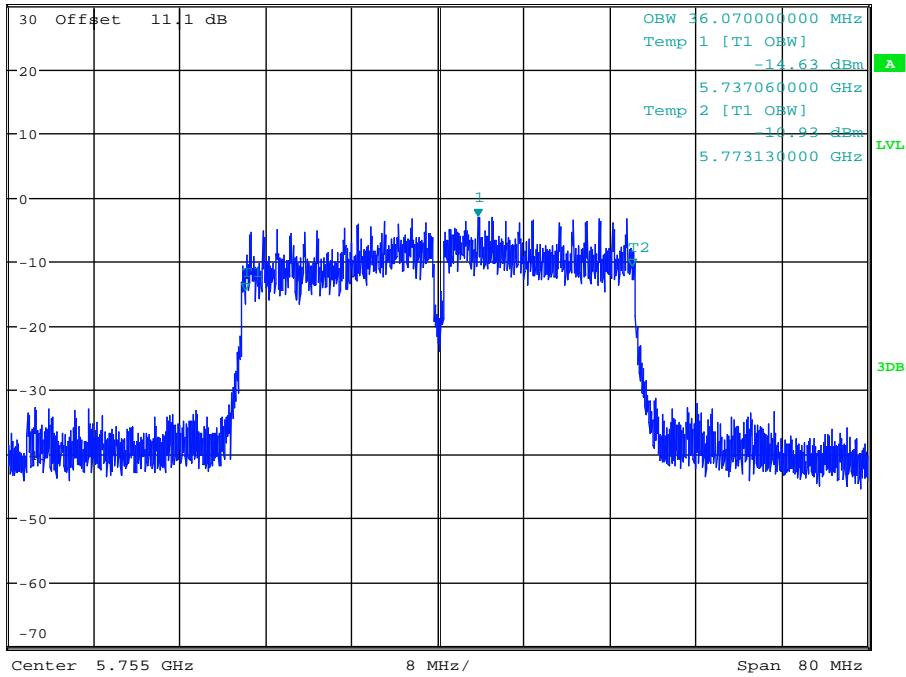

Date: 28.DEC.2017 22:11:29

### Occupied Bandwidth Measurement\_11N40SISO\_5755\_Ant2



Ref 30 dBm      \* Att 40 dB      \* RBW 100 kHz      Marker 1 [T1 ]  
\* VBW 300 kHz      -3.01 dBm  
SWT 35 ms      5.758770000 GHz

1 PK  
VIEW

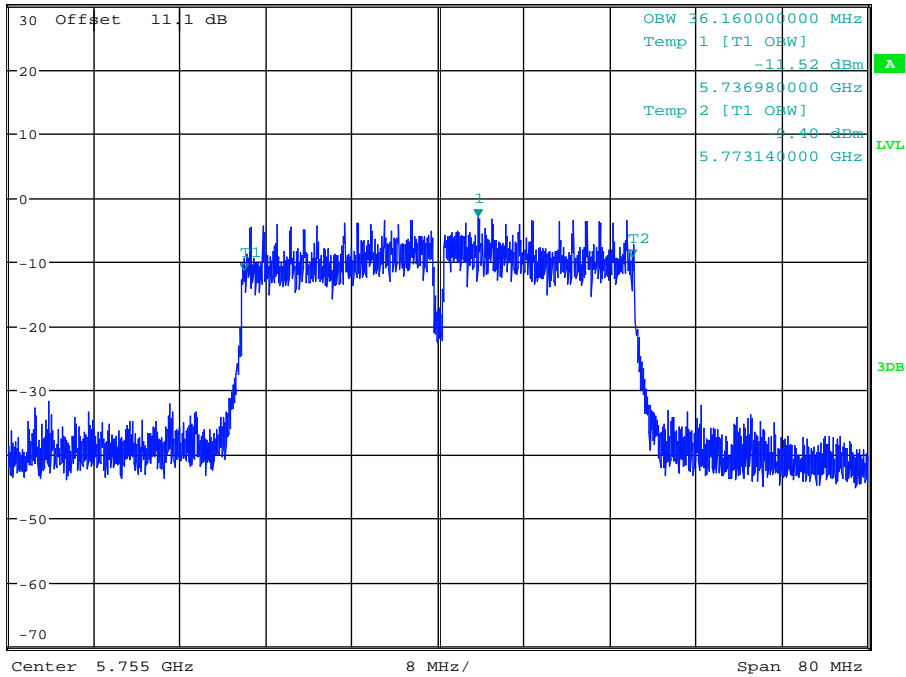

Date: 3.JAN.2018 15:11:15

### Occupied Bandwidth Measurement\_11N40SISO\_5795\_Ant1

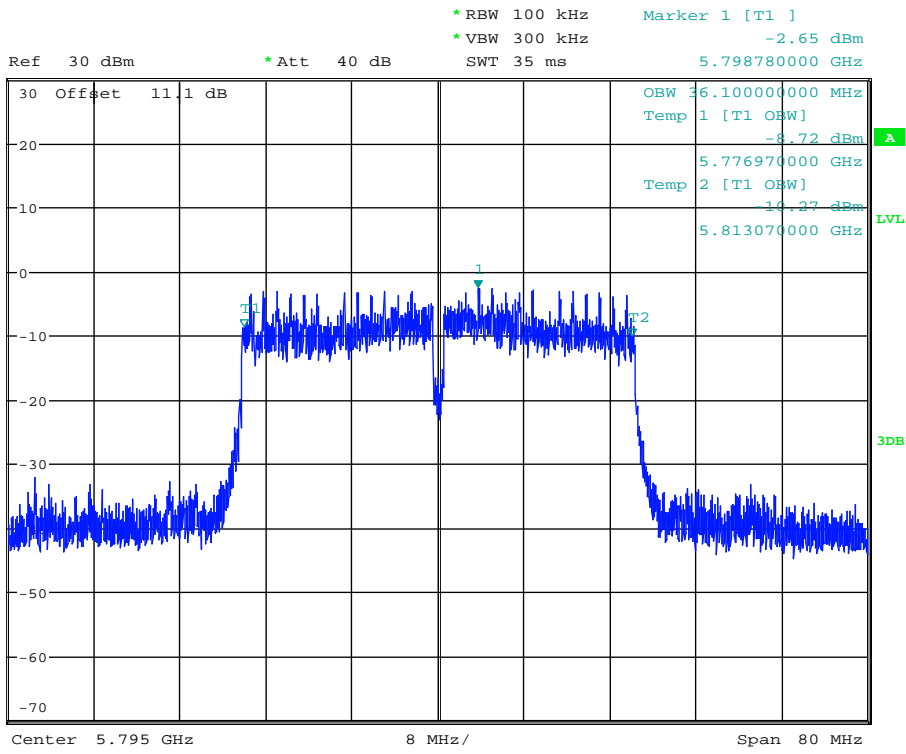

Date: 28.DEC.2017 22:20:30

### Occupied Bandwidth Measurement\_11N40SISO\_5795\_Ant2

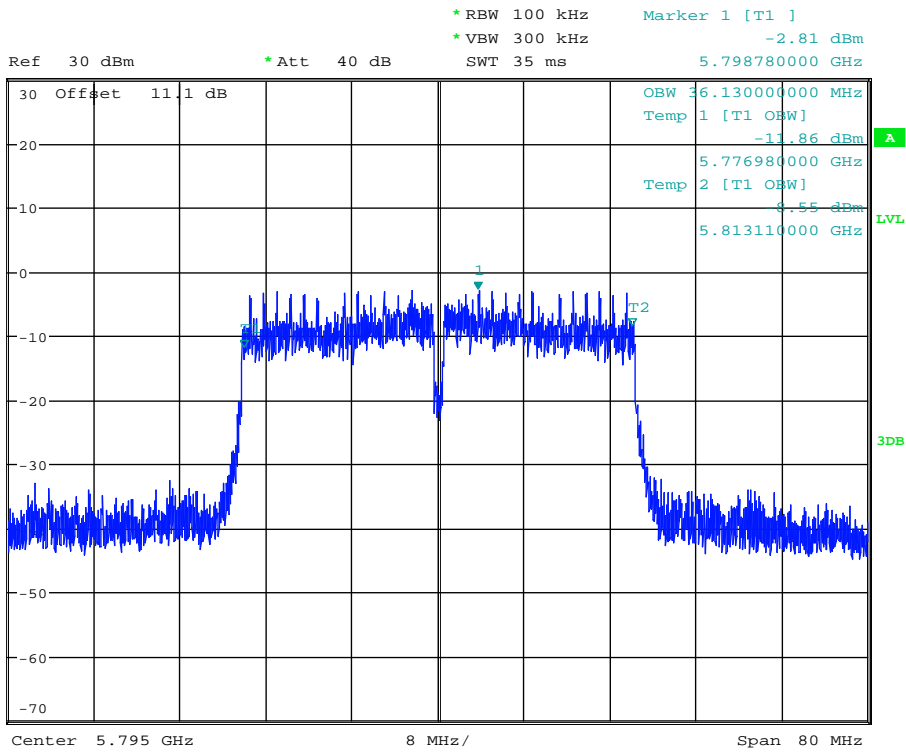

Date: 3.JAN.2018 15:16:24

### Occupied Bandwidth Measurement\_11AC20SISO\_5180\_Ant1



Ref 30 dBm      \* Att 40 dB      \* RBW 200 kHz      Marker 1 [T1 ]  
\* VBW 500 kHz      0.69 dBm  
SWT 35 ms      5.179515000 GHz

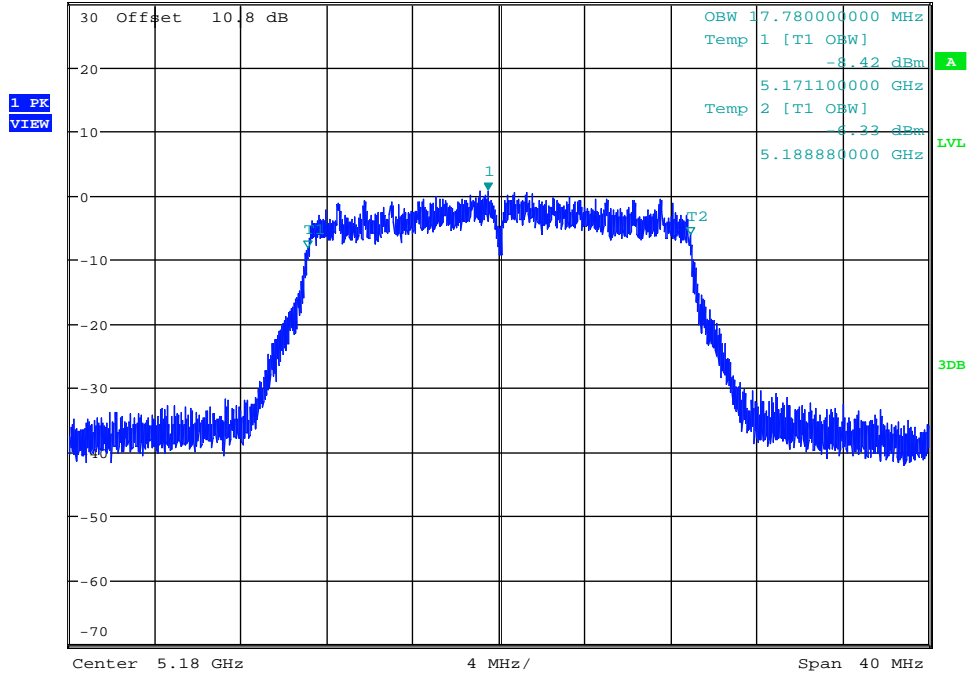

Date: 29.DEC.2017 19:55:41

### Occupied Bandwidth Measurement\_11AC20SISO\_5180\_Ant2



Ref 30 dBm      \* Att 40 dB      \* RBW 200 kHz      Marker 1 [T1 ]  
\* VBW 500 kHz      1.49 dBm  
SWT 35 ms      5.181995000 GHz

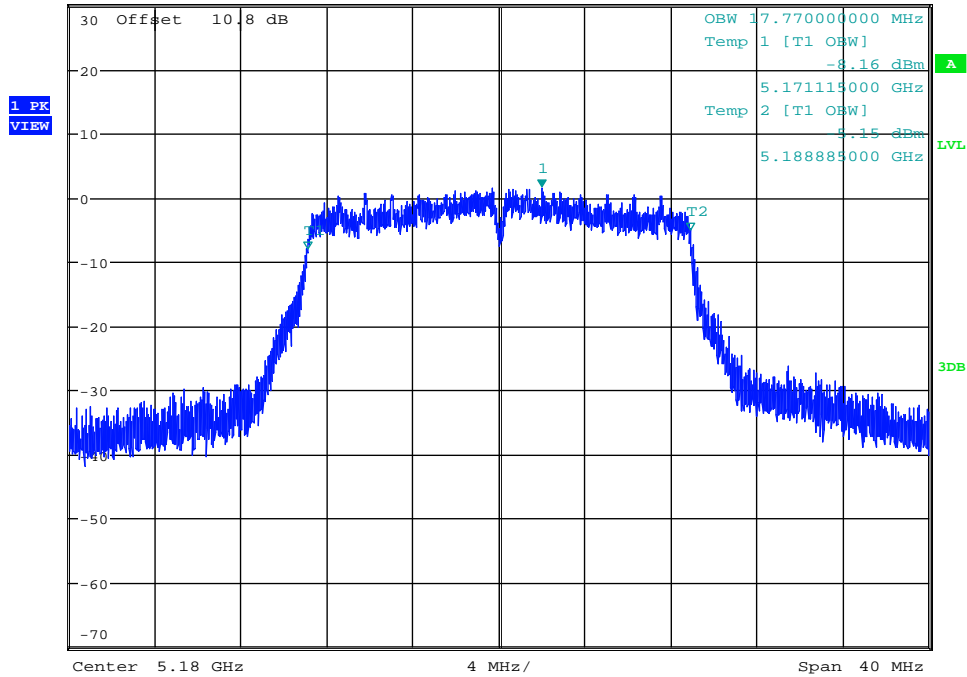

Date: 3.JAN.2018 15:21:12

### Occupied Bandwidth Measurement\_11AC20SISO\_5200\_Ant1



Ref 30 dBm      \* Att 40 dB      \* RBW 200 kHz      Marker 1 [T1 ]  
\* VBW 500 kHz      2.45 dBm  
SWT 35 ms      5.199760000 GHz

1 PK  
VIEW

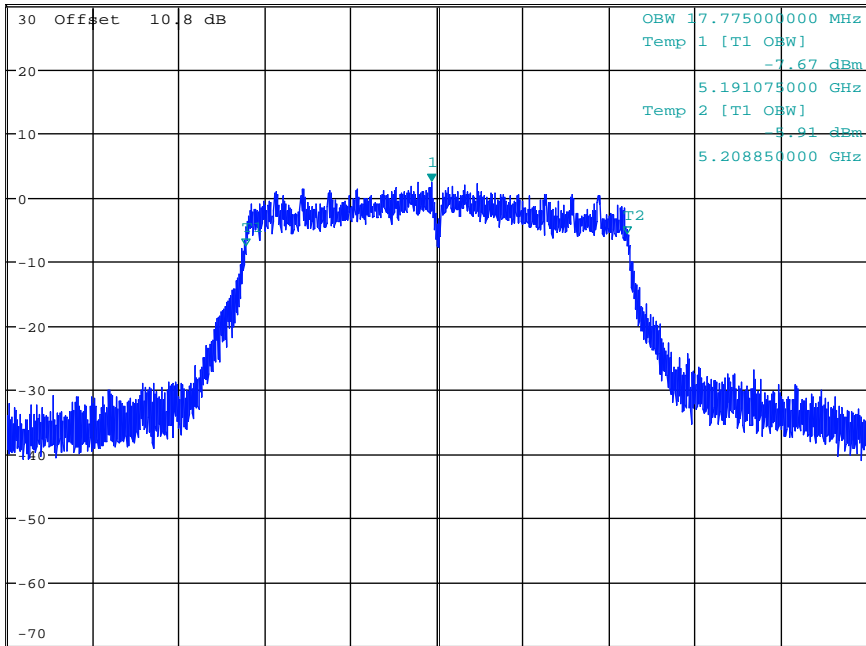

Center 5.2 GHz      4 MHz/      Span 40 MHz

Date: 29.DEC.2017 19:58:55

### Occupied Bandwidth Measurement\_11AC20SISO\_5200\_Ant2



Ref 30 dBm      \* Att 40 dB      \* RBW 200 kHz      Marker 1 [T1 ]  
\* VBW 500 kHz      2.50 dBm  
SWT 35 ms      5.201255000 GHz

1 PK  
VIEW

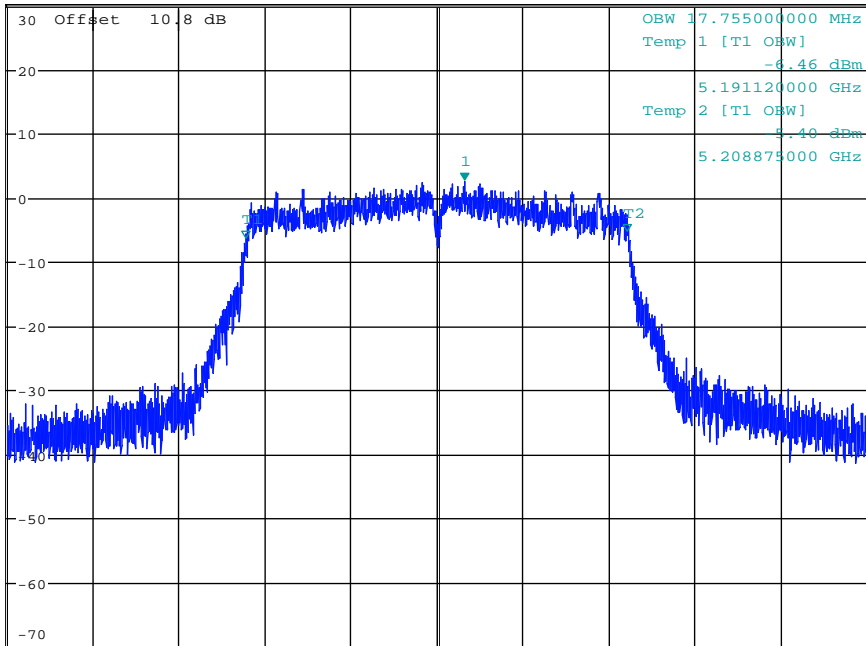

Center 5.2 GHz      4 MHz/      Span 40 MHz

Date: 3.JAN.2018 15:26:23

### Occupied Bandwidth Measurement\_11AC20SISO\_5240\_Ant1

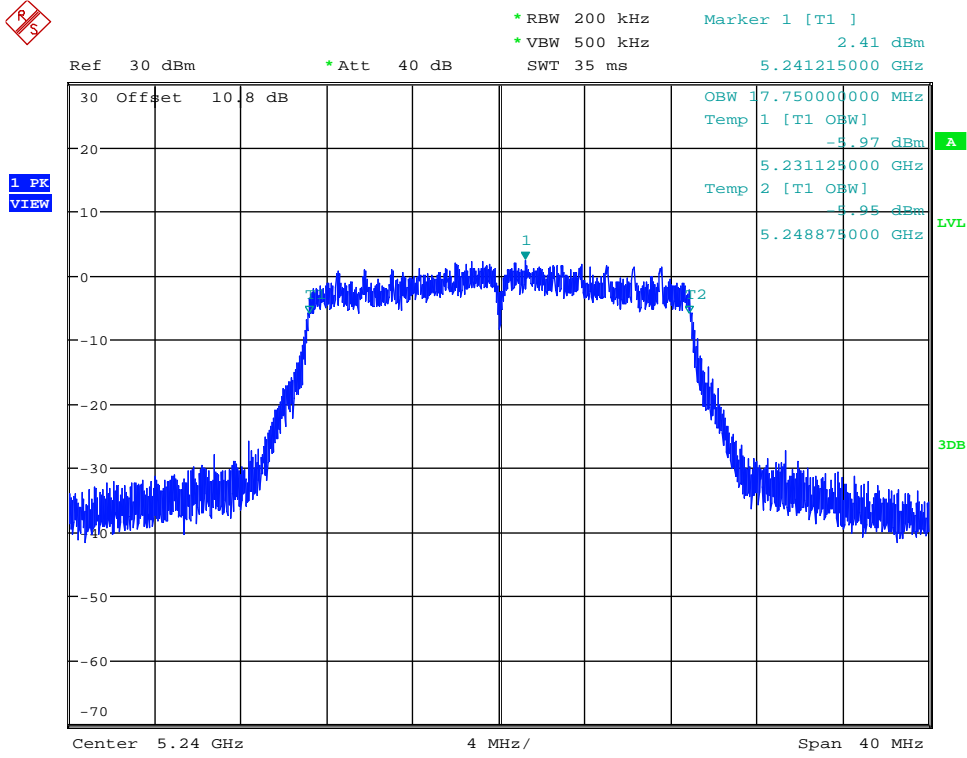

Date: 29.DEC.2017 20:04:15

### Occupied Bandwidth Measurement\_11AC20SISO\_5240\_Ant2

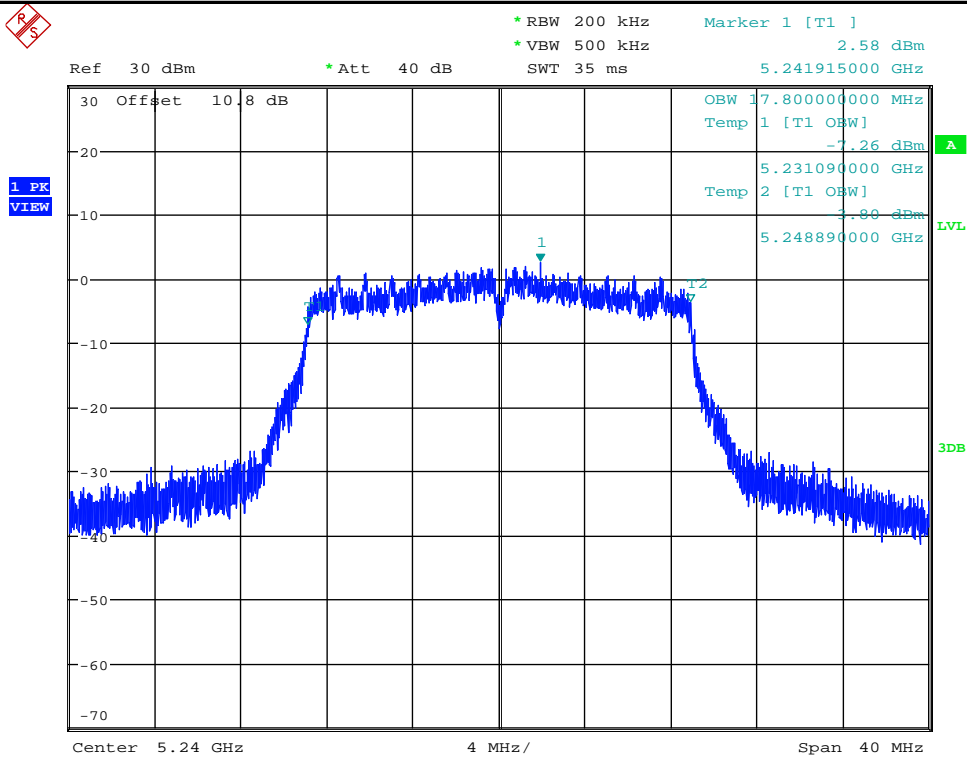

Date: 3.JAN.2018 15:31:14

### Occupied Bandwidth Measurement\_11AC20SISO\_5260\_Ant1



Ref 30 dBm      \* Att 40 dB      \* RBW 200 kHz      Marker 1 [T1 ]  
\* VBW 500 kHz      -1.65 dBm  
SWT 35 ms      5.259430000 GHz

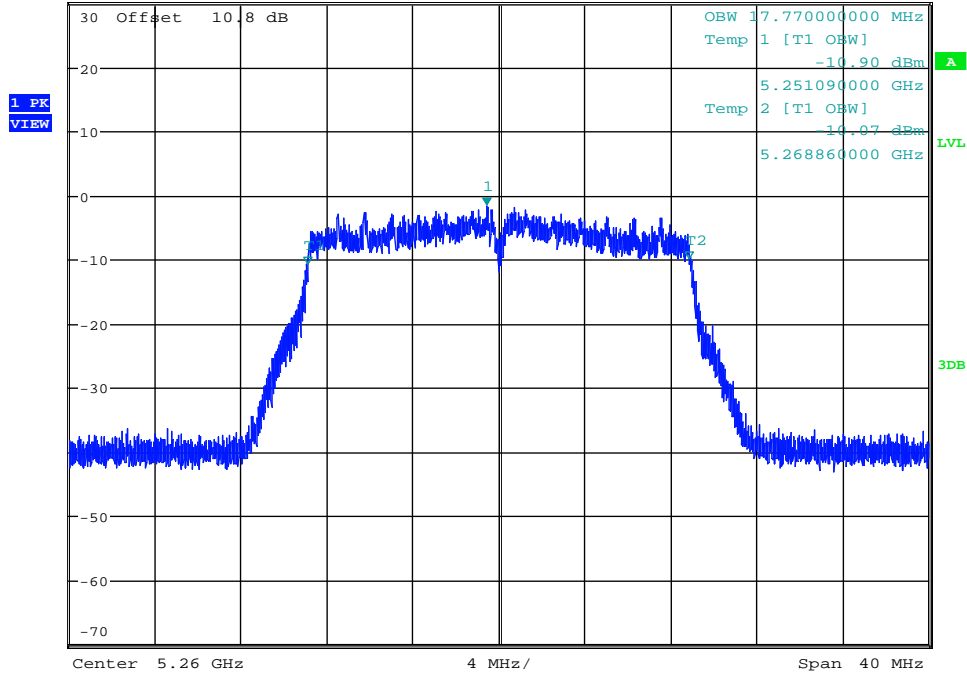

Date: 29.DEC.2017 20:09:31

### Occupied Bandwidth Measurement\_11AC20SISO\_5260\_Ant2



Ref 30 dBm      \* Att 40 dB      \* RBW 200 kHz      Marker 1 [T1 ]  
\* VBW 500 kHz      -1.29 dBm  
SWT 35 ms      5.261305000 GHz

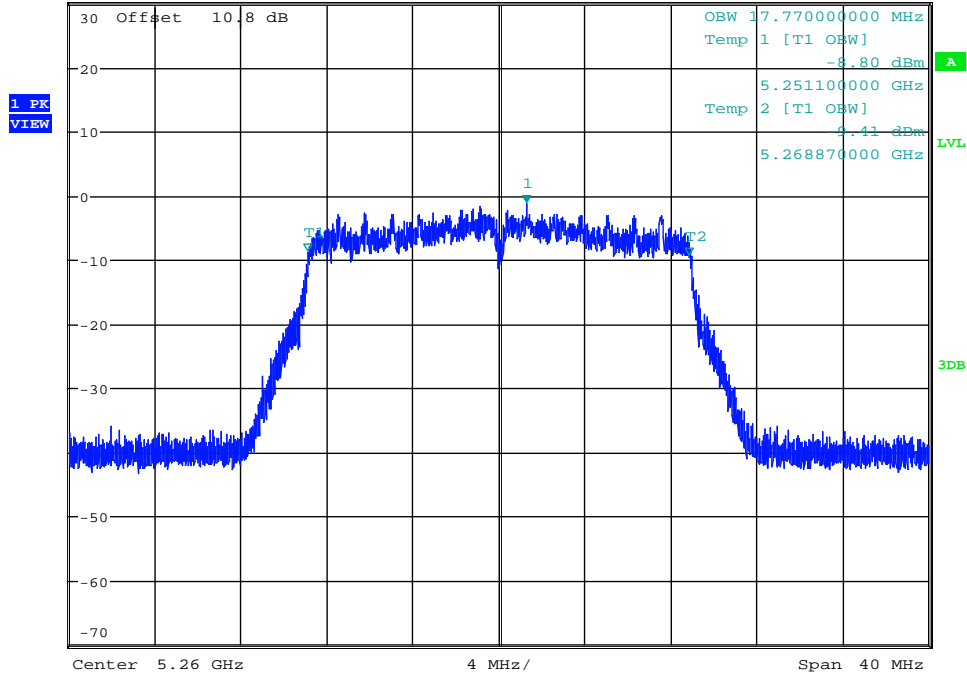

Date: 3.JAN.2018 15:37:06

### Occupied Bandwidth Measurement\_11AC20SISO\_5280\_Ant1

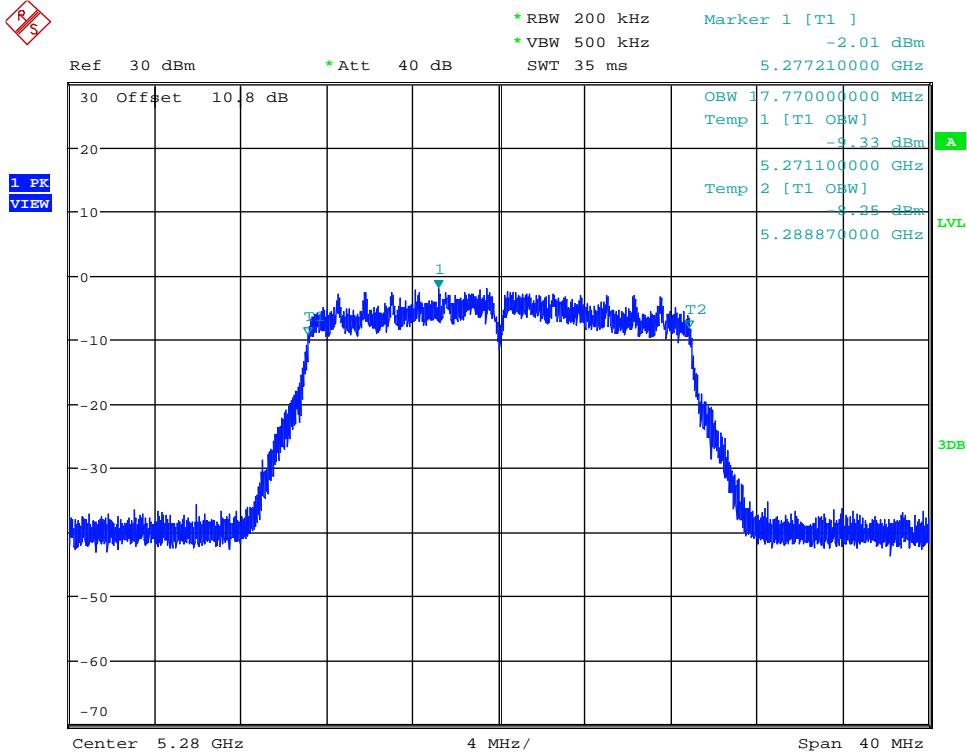

Date: 29.DEC.2017 20:15:18

### Occupied Bandwidth Measurement\_11AC20SISO\_5280\_Ant2

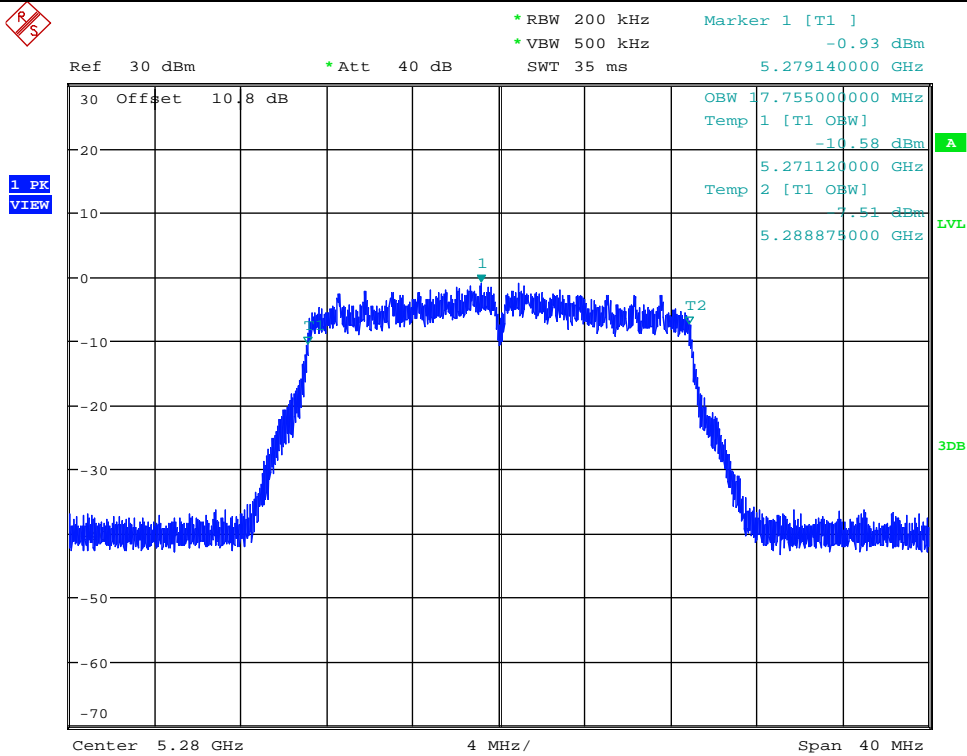

Date: 3.JAN.2018 15:42:27

### Occupied Bandwidth Measurement\_11AC20SISO\_5320\_Ant1

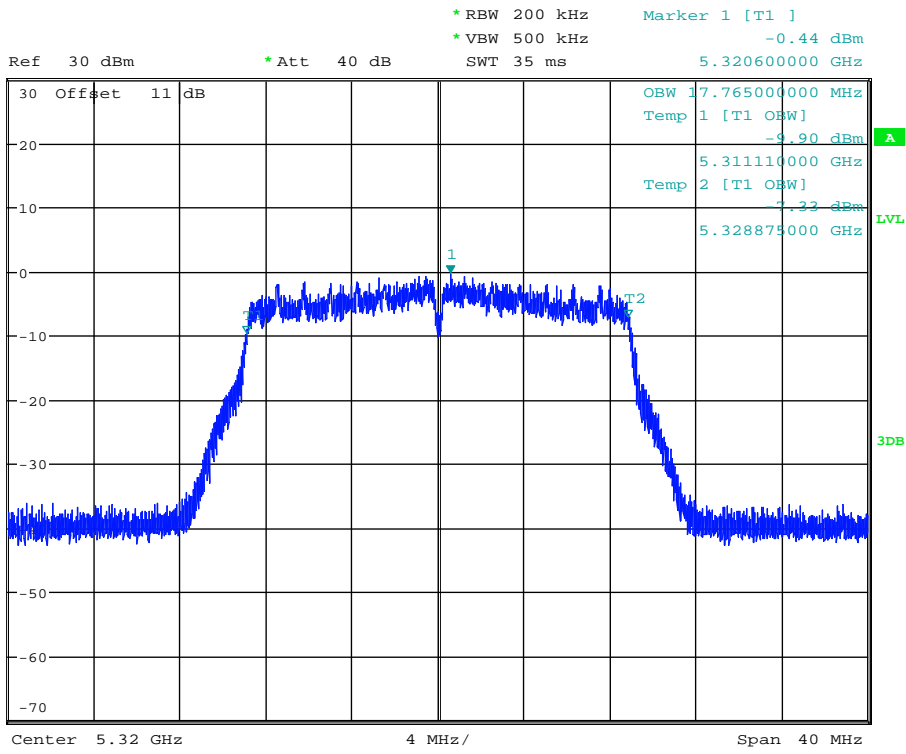

Date: 29.DEC.2017 20:20:35

### Occupied Bandwidth Measurement\_11AC20SISO\_5320\_Ant2

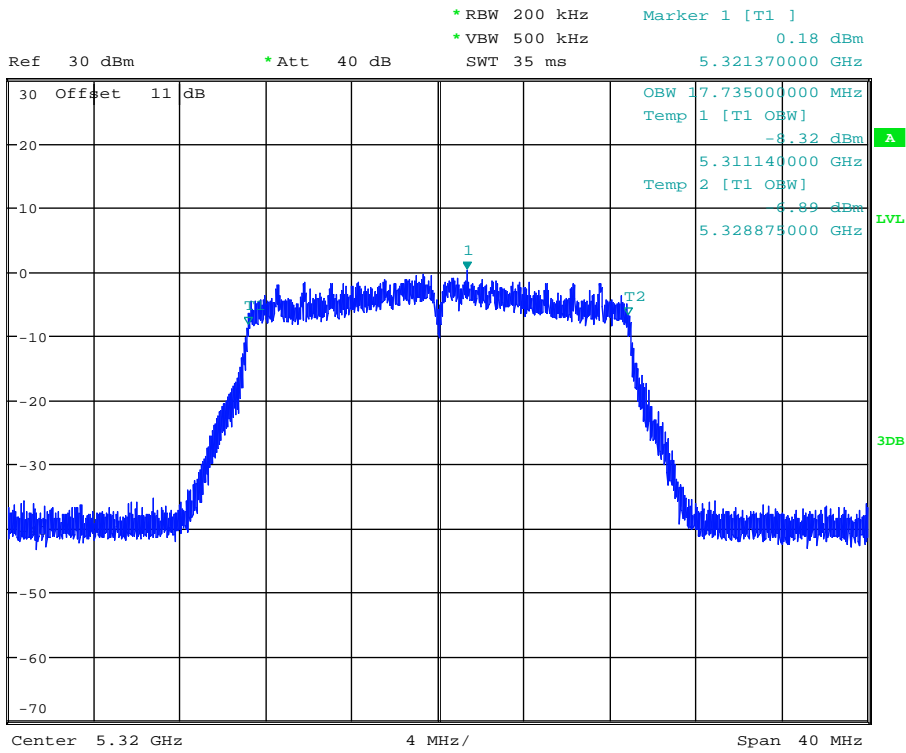

Date: 3.JAN.2018 15:49:53

### Occupied Bandwidth Measurement\_11AC20SISO\_5500\_Ant1



Ref 30 dBm      \* Att 40 dB      \* RBW 200 kHz      Marker 1 [T1 ]  
\* VBW 500 kHz      3.00 dBm  
SWT 35 ms      5.499490000 GHz

1 PK  
VIEW

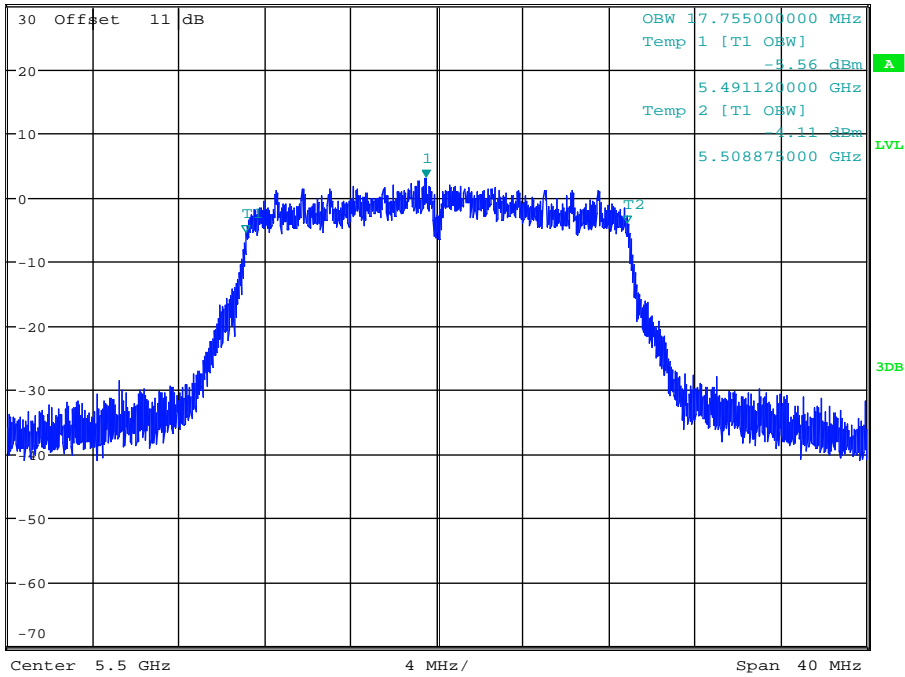

Date: 29.DEC.2017 20:26:14

### Occupied Bandwidth Measurement\_11AC20SISO\_5500\_Ant2



Ref 30 dBm      \* Att 40 dB      \* RBW 200 kHz      Marker 1 [T1 ]  
\* VBW 500 kHz      1.83 dBm  
SWT 35 ms      5.501290000 GHz

1 PK  
VIEW

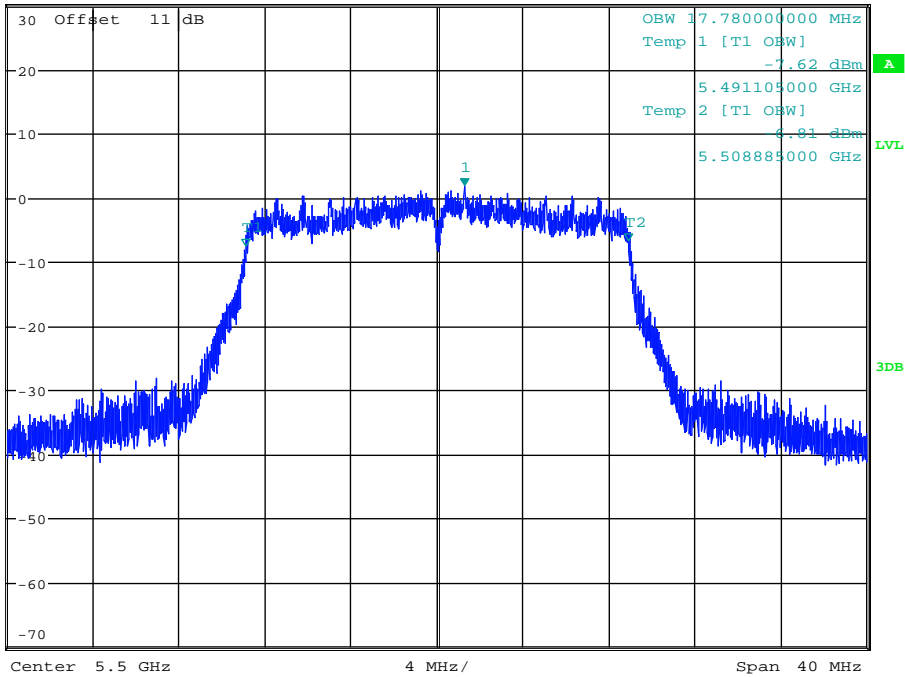

Date: 3.JAN.2018 16:04:00

### Occupied Bandwidth Measurement\_11AC20SISO\_5580\_Ant1

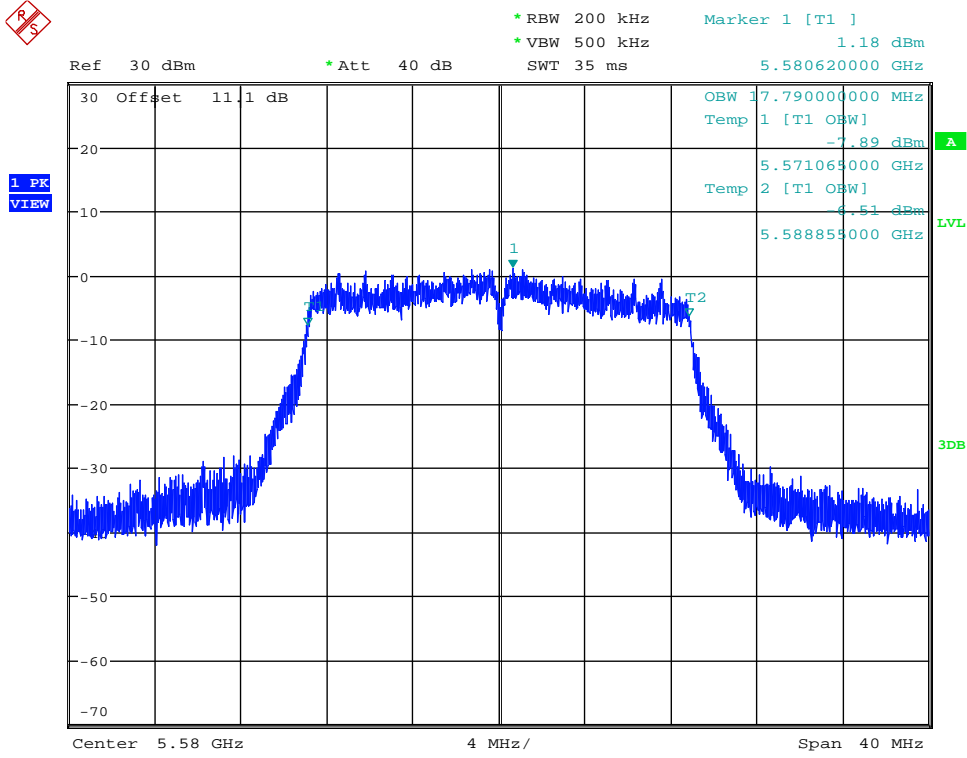

Date: 29.DEC.2017 20:33:52

### Occupied Bandwidth Measurement\_11AC20SISO\_5580\_Ant2

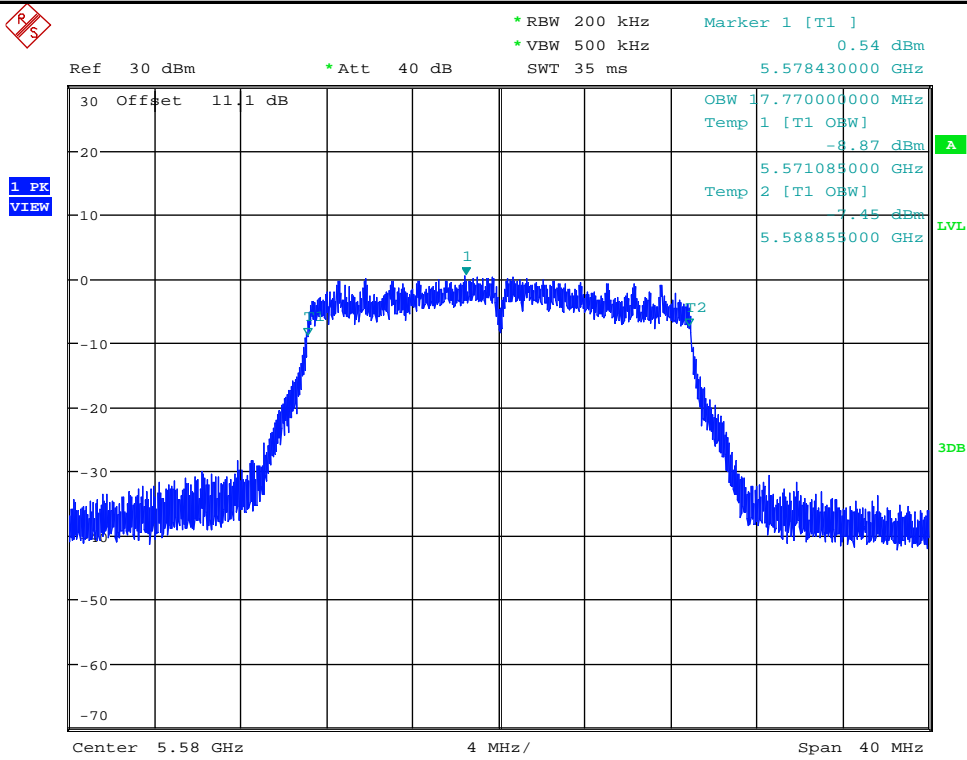

Date: 3.JAN.2018 16:09:01

### Occupied Bandwidth Measurement\_11AC20SISO\_5700\_Ant1

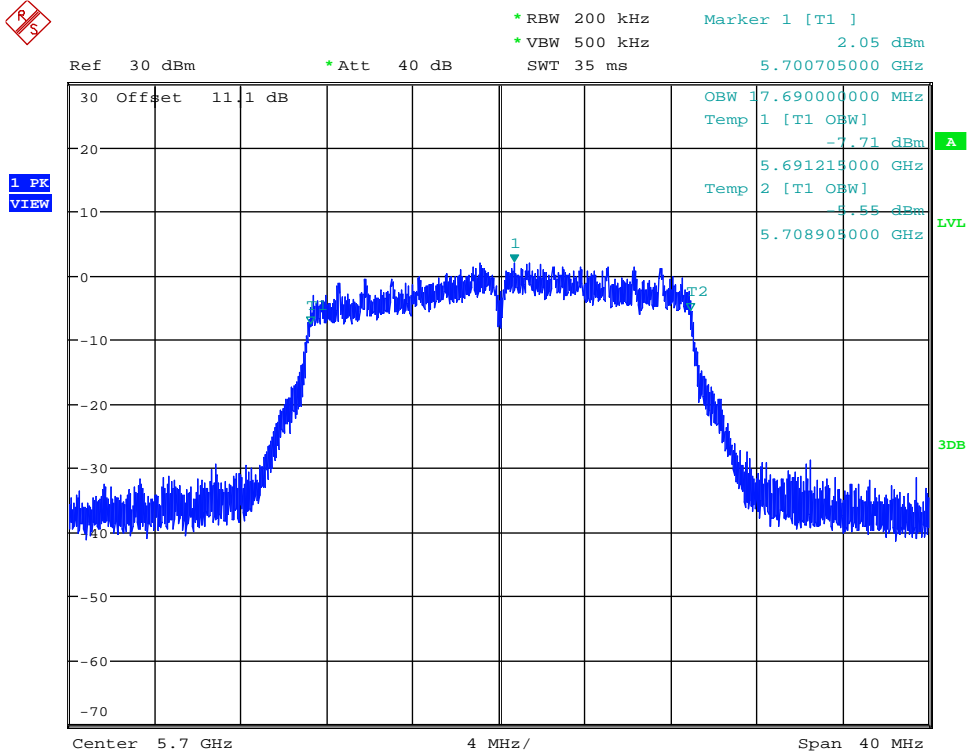

Date: 29.DEC.2017 20:39:51

### Occupied Bandwidth Measurement\_11AC20SISO\_5700\_Ant2

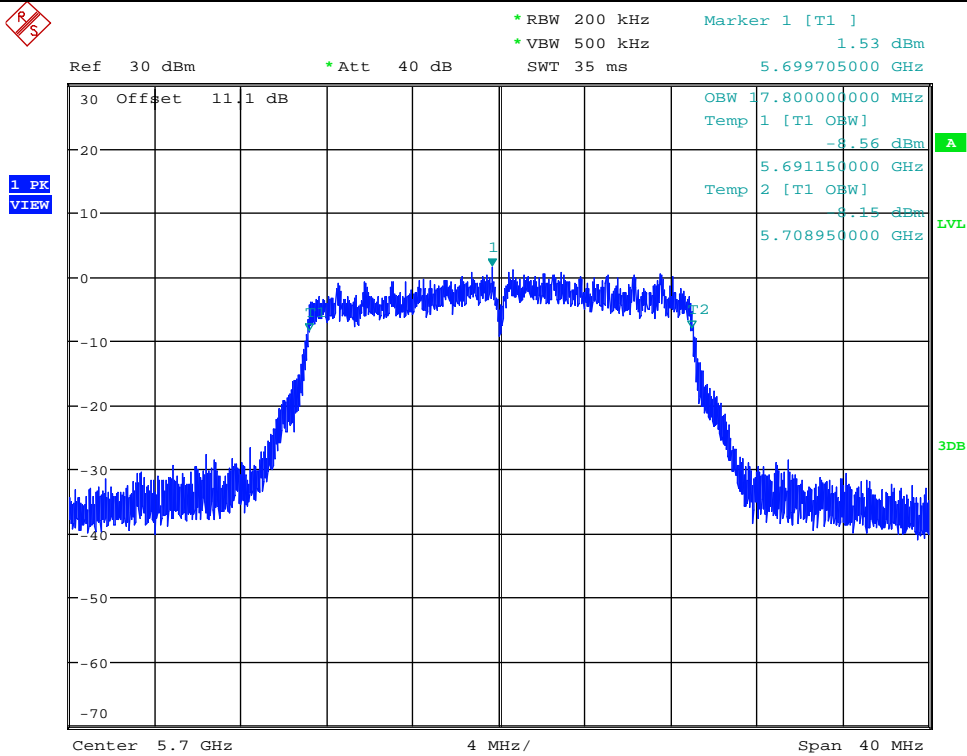

Date: 3.JAN.2018 16:13:51

### Occupied Bandwidth Measurement\_11AC20SISO\_5745\_Ant1

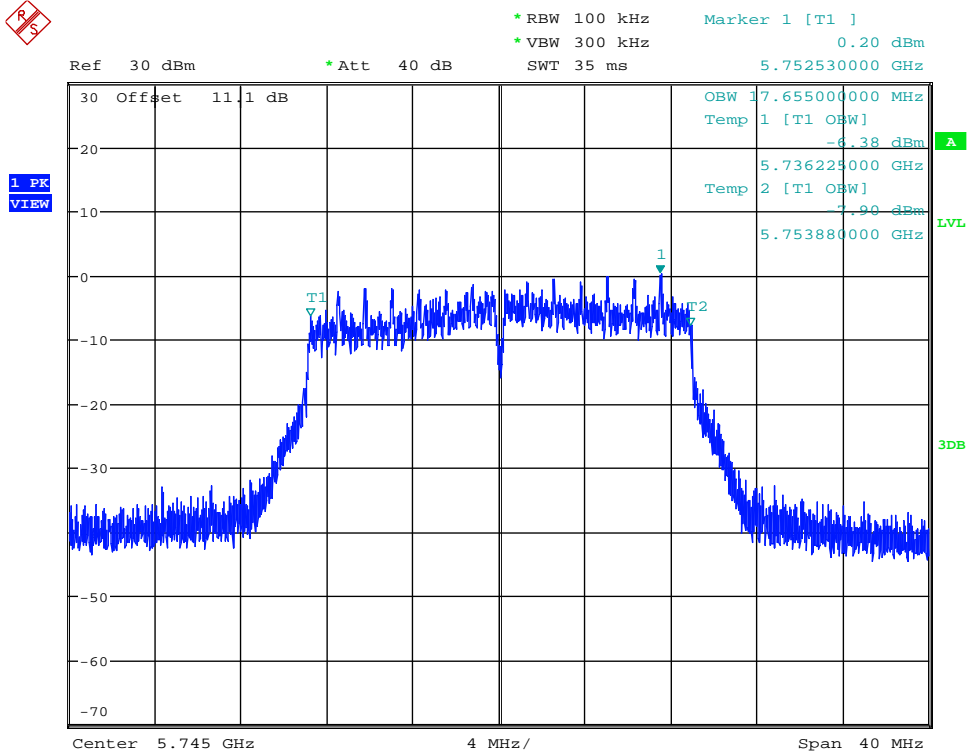

Date: 29.DEC.2017 20:45:36

### Occupied Bandwidth Measurement\_11AC20SISO\_5745\_Ant2

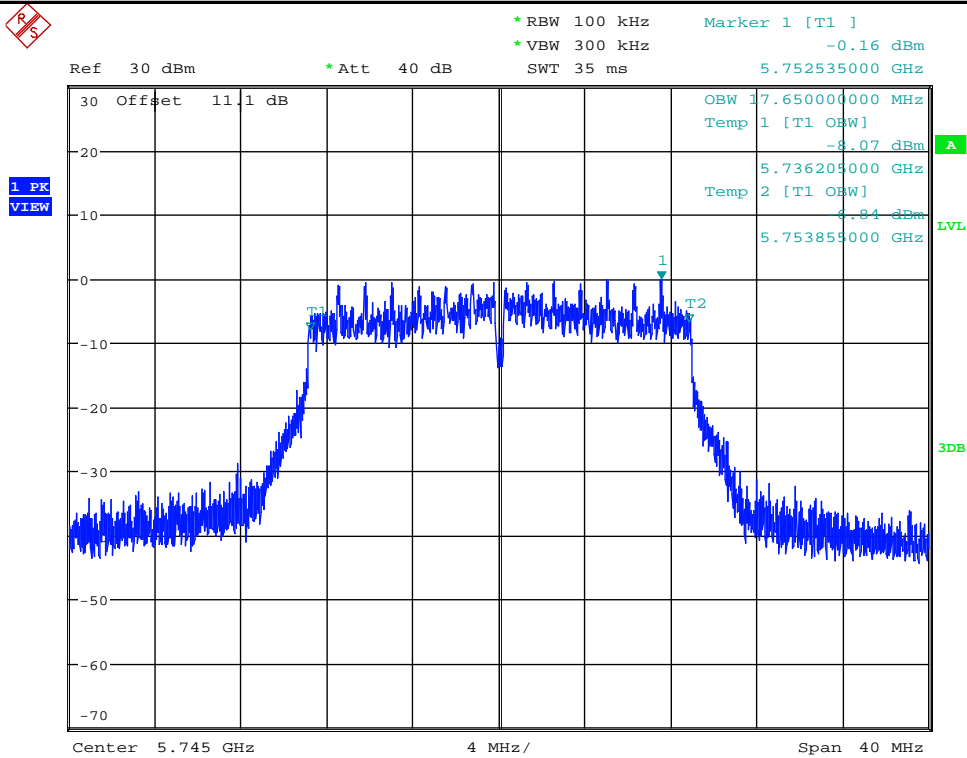

Date: 3.JAN.2018 16:25:54

### Occupied Bandwidth Measurement\_11AC20SISO\_5785\_Ant1



Ref 30 dBm      \* Att 40 dB      \* RBW 100 kHz      Marker 1 [T1 ]  
\* VBW 300 kHz      0.38 dBm  
SWT 35 ms      5.780025000 GHz

1 PK  
VIEW

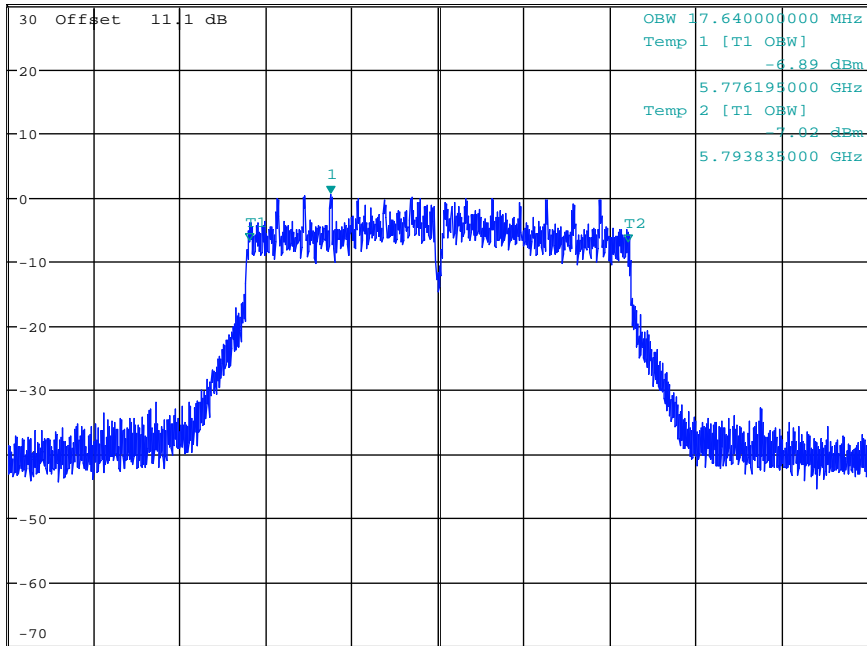

Center 5.785 GHz      4 MHz/      Span 40 MHz

Date: 29.DEC.2017 20:50:11

### Occupied Bandwidth Measurement\_11AC20SISO\_5785\_Ant2



Ref 30 dBm      \* Att 40 dB      \* RBW 100 kHz      Marker 1 [T1 ]  
\* VBW 300 kHz      0.26 dBm  
SWT 35 ms      5.780025000 GHz

1 PK  
VIEW

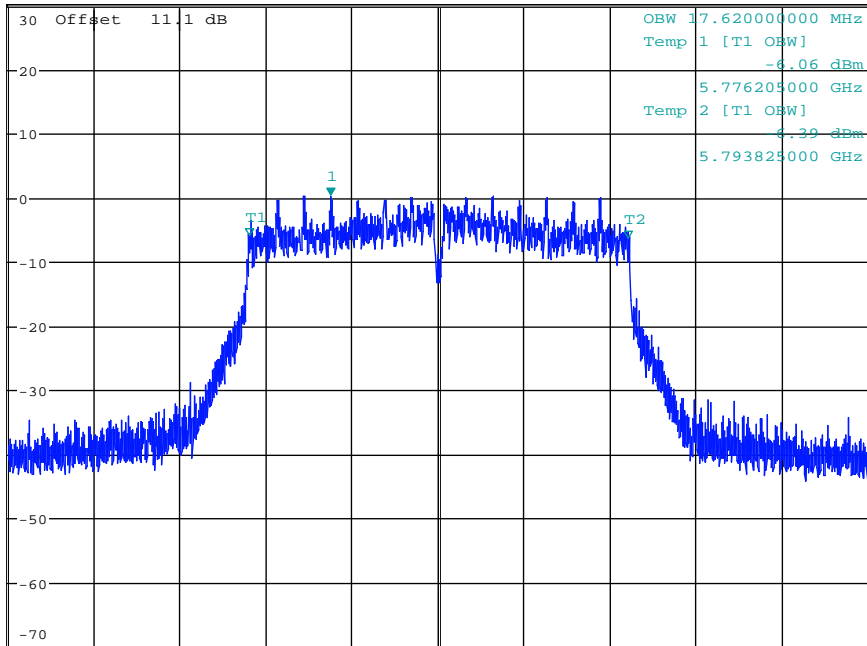

Center 5.785 GHz      4 MHz/      Span 40 MHz

Date: 3.JAN.2018 16:31:36

### Occupied Bandwidth Measurement\_11AC20SISO\_5825\_Ant1



Ref 30 dBm      \* Att 40 dB      \* RBW 100 kHz      \* VBW 300 kHz      Marker 1 [T1 ]  
SWT 35 ms      5.827530000 GHz      -0.06 dBm

1 PK VIEW

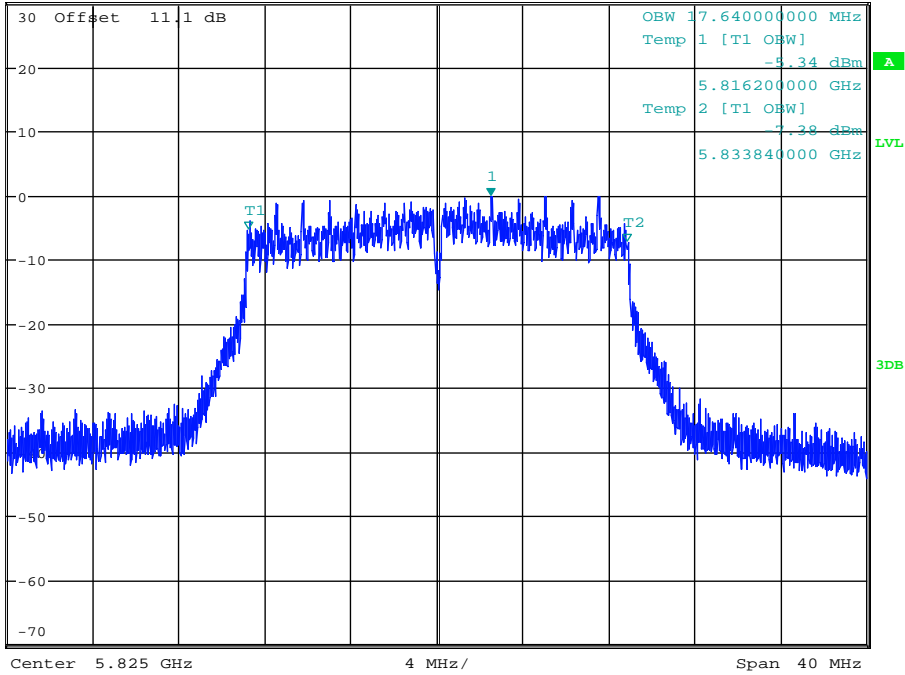

Date: 29.DEC.2017 20:54:10

### Occupied Bandwidth Measurement\_11AC20SISO\_5825\_Ant2



Ref 30 dBm      \* Att 40 dB      \* RBW 100 kHz      \* VBW 300 kHz      Marker 1 [T1 ]  
SWT 35 ms      5.827520000 GHz      -0.19 dBm

1 PK VIEW

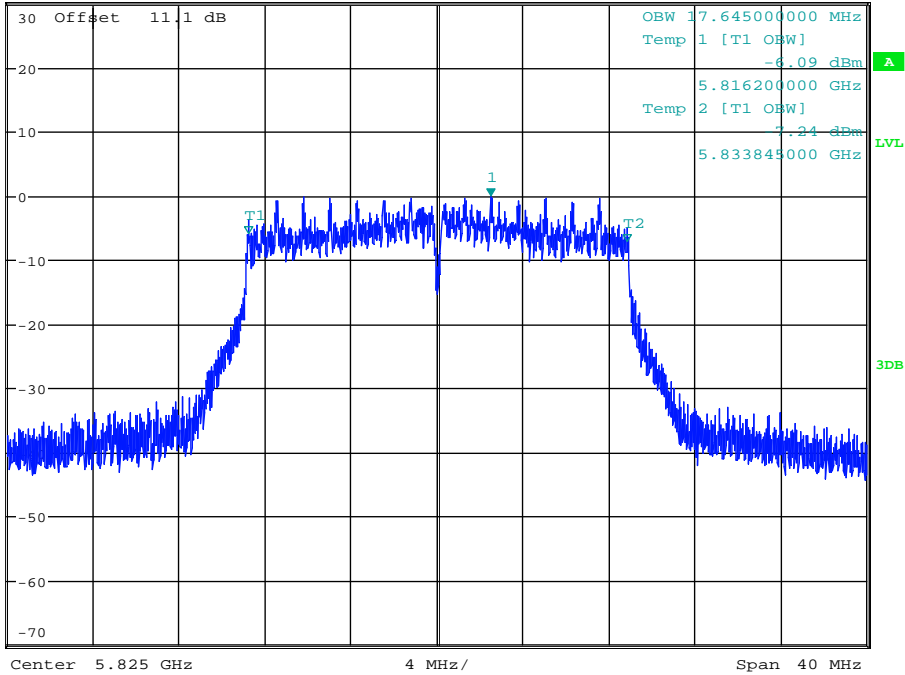

Date: 3.JAN.2018 16:35:50

### Occupied Bandwidth Measurement\_11AC40SISO\_5190\_Ant1

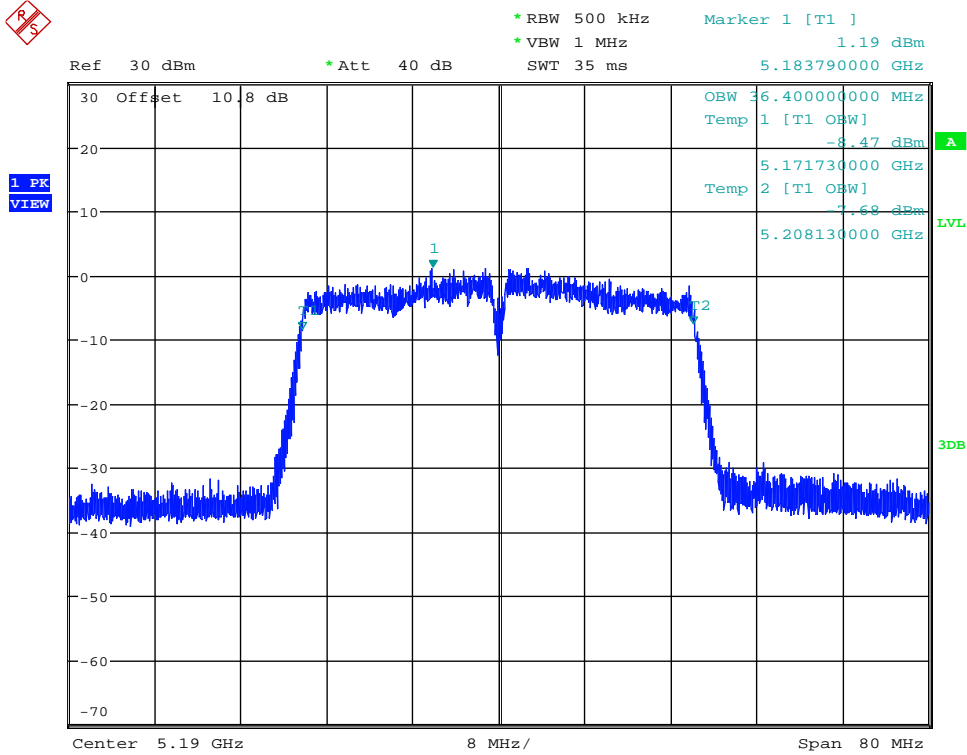

Date: 2.JAN.2018 13:39:51

### Occupied Bandwidth Measurement\_11AC40SISO\_5190\_Ant2

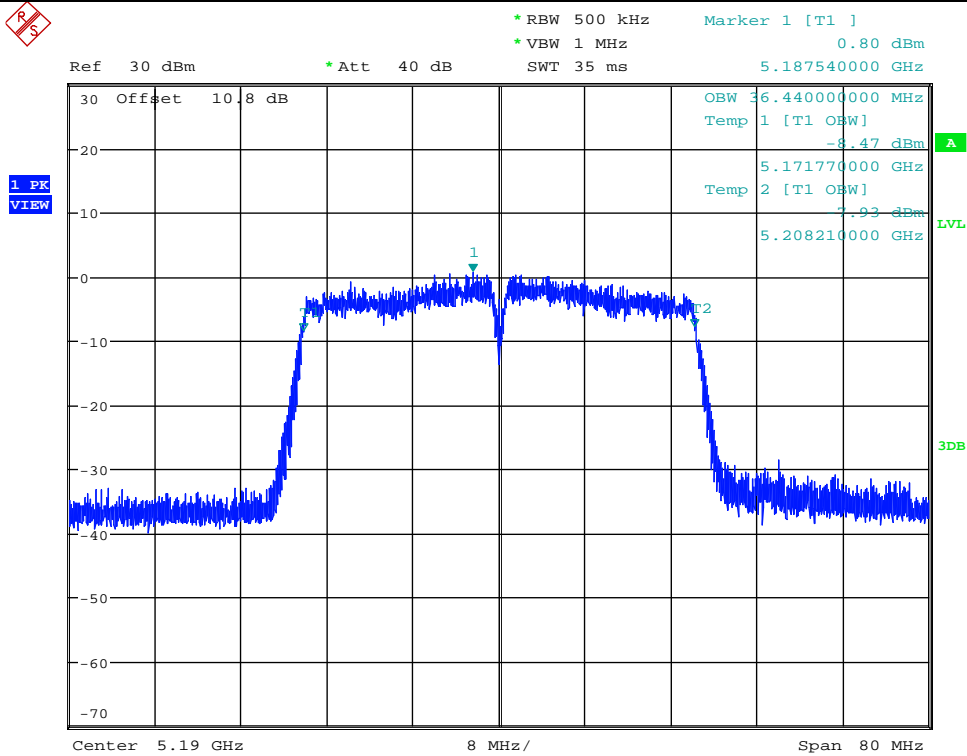

Date: 3.JAN.2018 16:40:08

### Occupied Bandwidth Measurement\_11AC40SISO\_5230\_Ant1

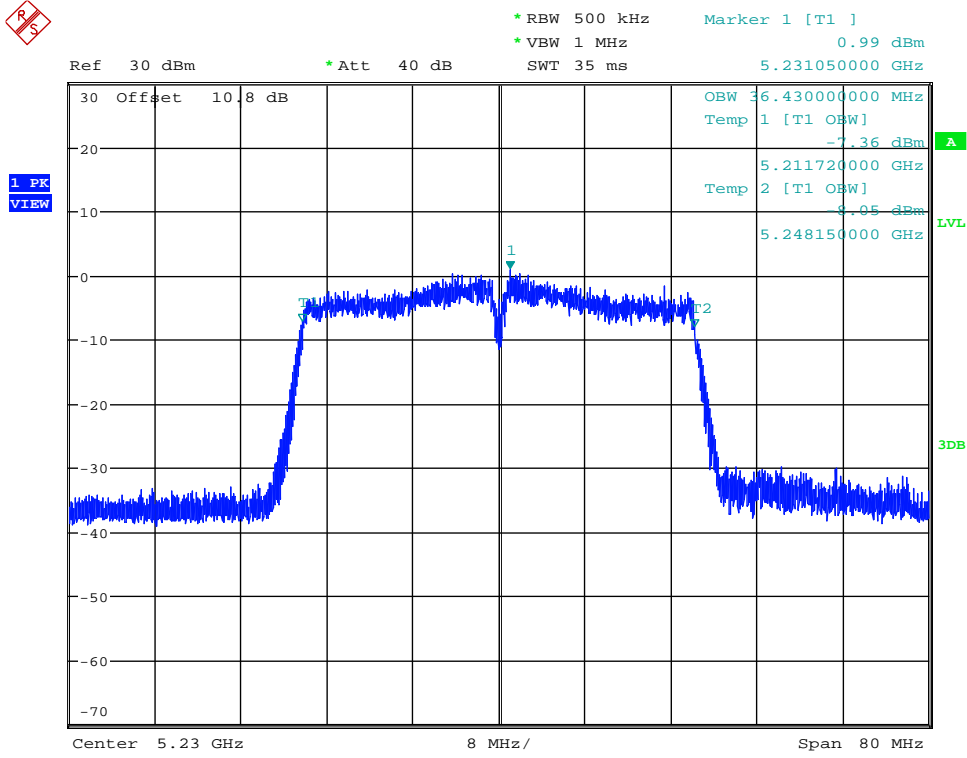

Date: 2.JAN.2018 13:45:26

### Occupied Bandwidth Measurement\_11AC40SISO\_5230\_Ant2

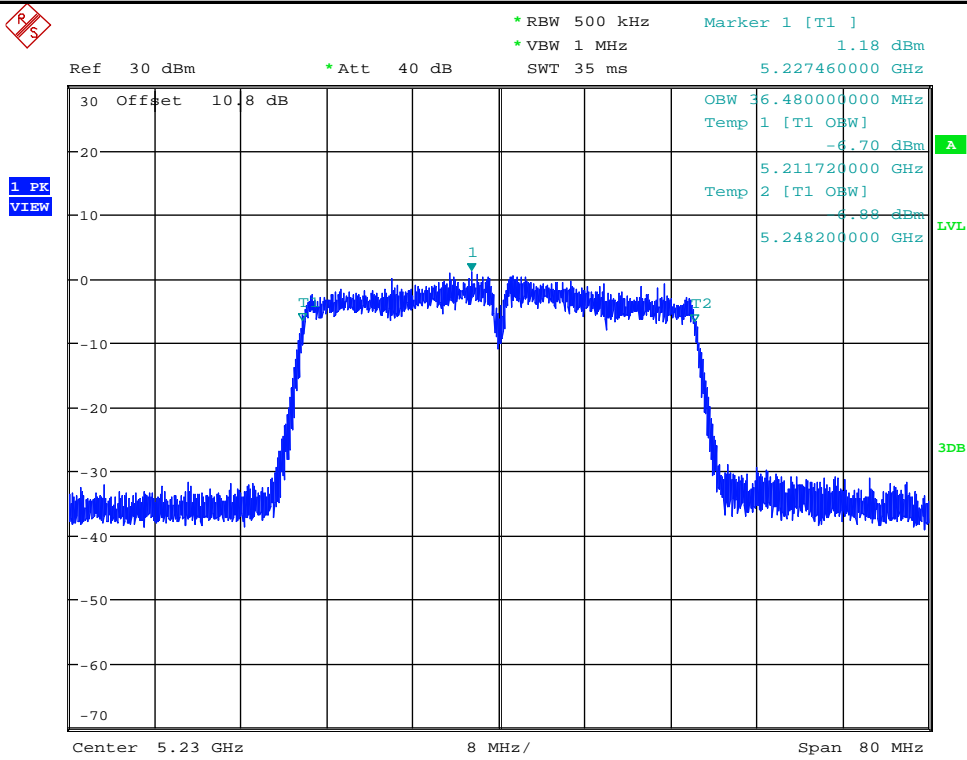

Date: 3.JAN.2018 16:44:42

### Occupied Bandwidth Measurement\_11AC40SISO\_5270\_Ant1



Ref 30 dBm      \* Att 40 dB      \* RBW 500 kHz      Marker 1 [T1 ]  
\* VBW 1 MHz      0.19 dBm  
SWT 35 ms      5.268870000 GHz

1 PK  
VIEW

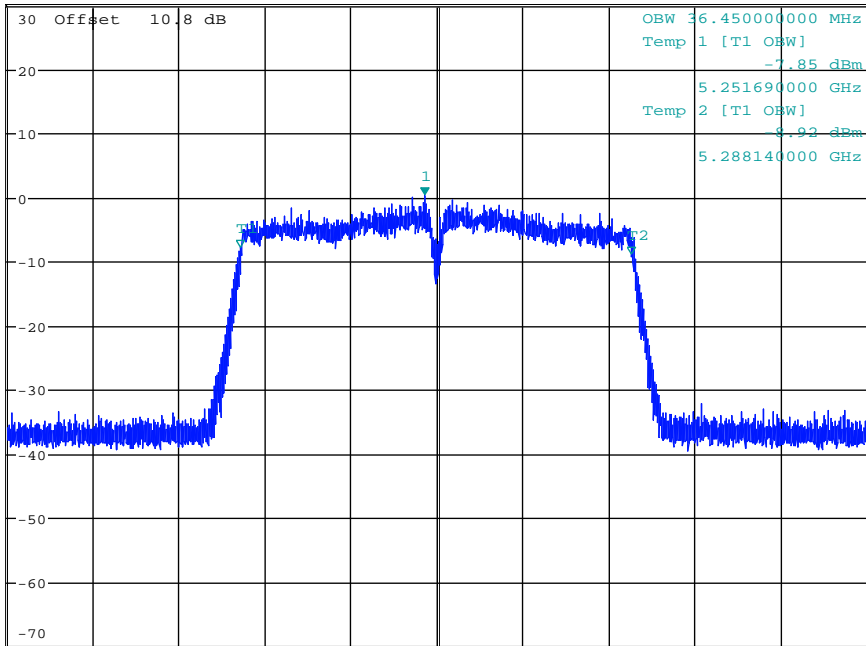

Center 5.27 GHz      8 MHz/      Span 80 MHz

Date: 2.JAN.2018 13:50:00

### Occupied Bandwidth Measurement\_11AC40SISO\_5270\_Ant2



Ref 30 dBm      \* Att 40 dB      \* RBW 500 kHz      Marker 1 [T1 ]  
\* VBW 1 MHz      -0.12 dBm  
SWT 35 ms      5.272790000 GHz

1 PK  
VIEW

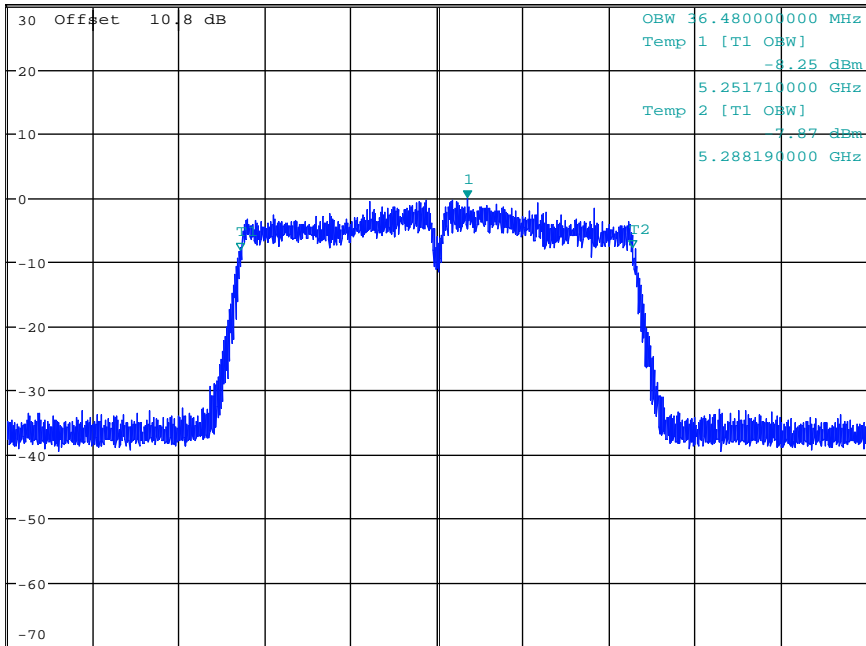

Center 5.27 GHz      8 MHz/      Span 80 MHz

Date: 3.JAN.2018 16:49:36

### Occupied Bandwidth Measurement\_11AC40SISO\_5310\_Ant1



Ref 30 dBm      \* Att 40 dB      \* RBW 500 kHz      Marker 1 [T1 ]  
\* VBW 1 MHz      0.46 dBm  
SWT 35 ms      5.311390000 GHz

1 PK  
VIEW

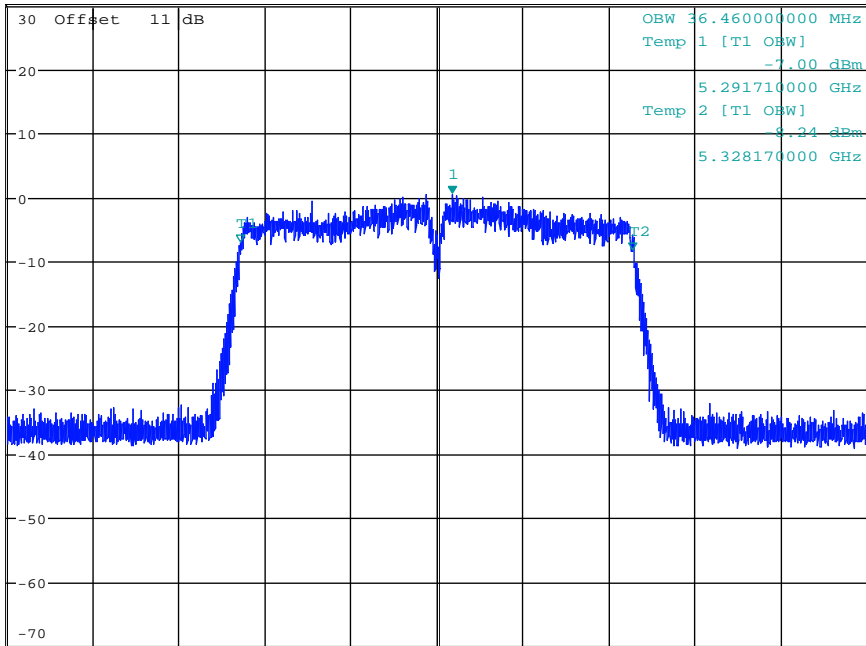

Center 5.31 GHz      8 MHz/      Span 80 MHz

Date: 2.JAN.2018 13:55:04

### Occupied Bandwidth Measurement\_11AC40SISO\_5310\_Ant2



Ref 30 dBm      \* Att 40 dB      \* RBW 500 kHz      Marker 1 [T1 ]  
\* VBW 1 MHz      0.62 dBm  
SWT 35 ms      5.311000000 GHz

1 PK  
VIEW

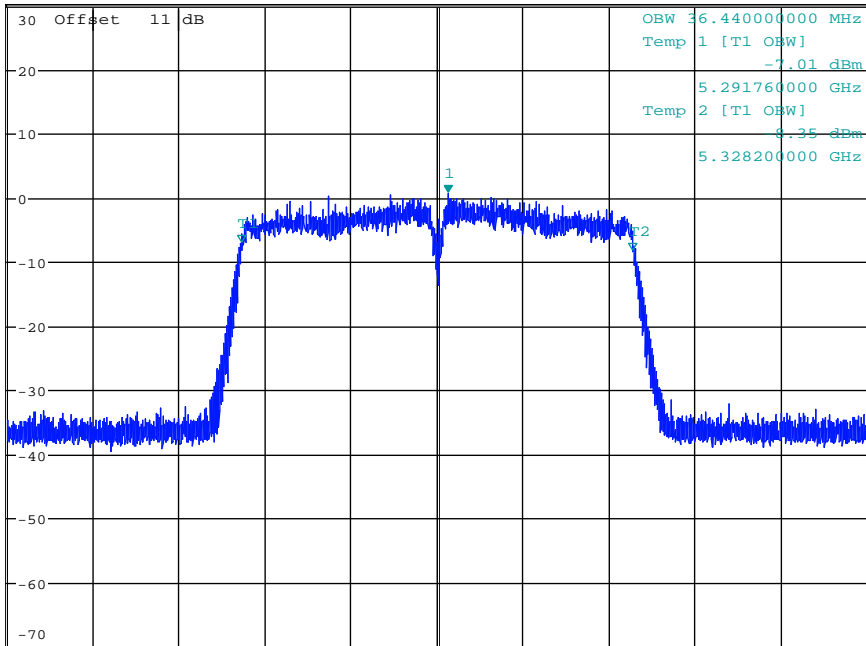

Center 5.31 GHz      8 MHz/      Span 80 MHz

Date: 3.JAN.2018 16:54:42

### Occupied Bandwidth Measurement\_11AC40SISO\_5510\_Ant1

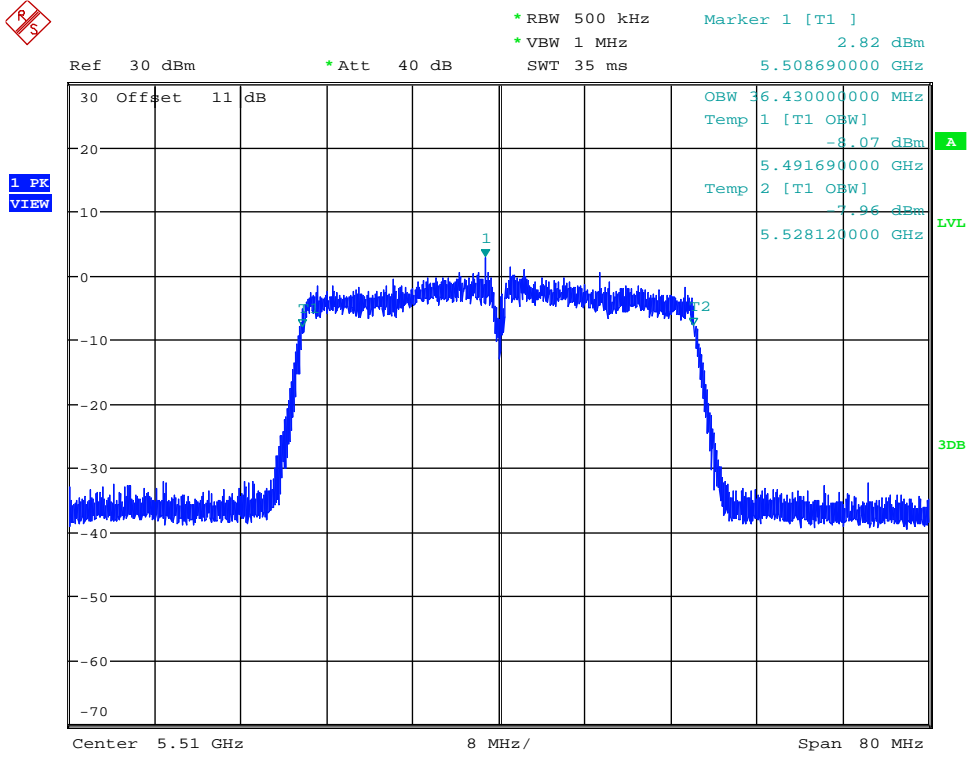

Date: 2.JAN.2018 14:00:04

### Occupied Bandwidth Measurement\_11AC40SISO\_5510\_Ant2

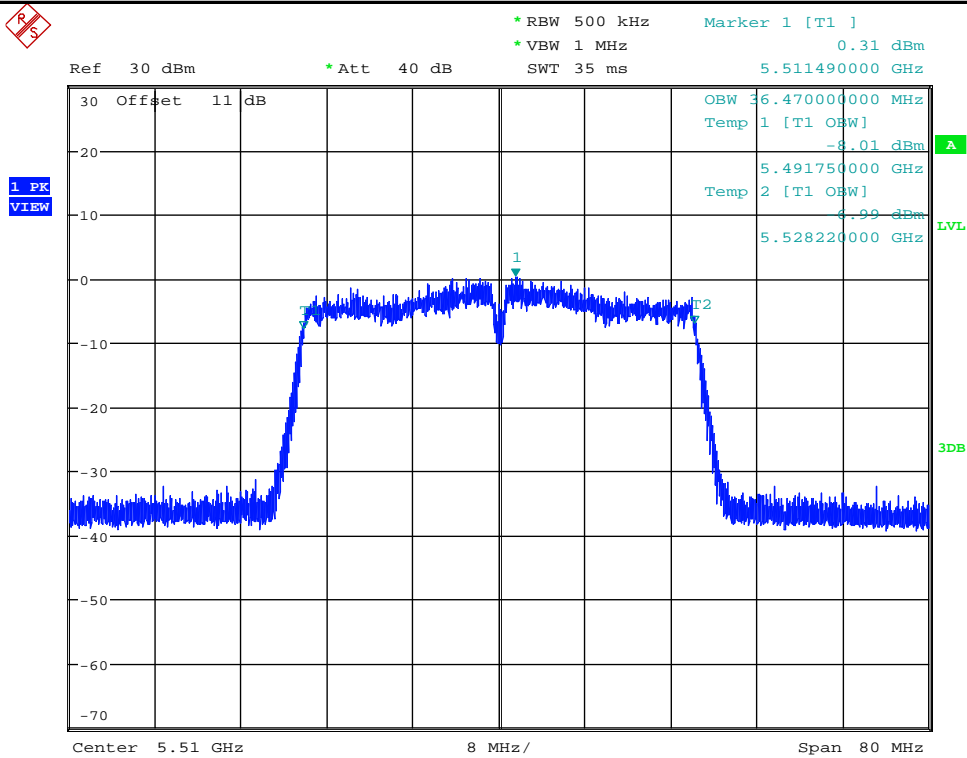

Date: 3.JAN.2018 17:07:05

### Occupied Bandwidth Measurement\_11AC40SISO\_5550\_Ant1



\*RBW 500 kHz      Marker 1 [T1 ]  
\*VBW 1 MHz      -0.70 dBm  
Ref 30 dBm      \*Att 40 dB      SWT 35 ms      5.552820000 GHz

1 PK  
VIEW

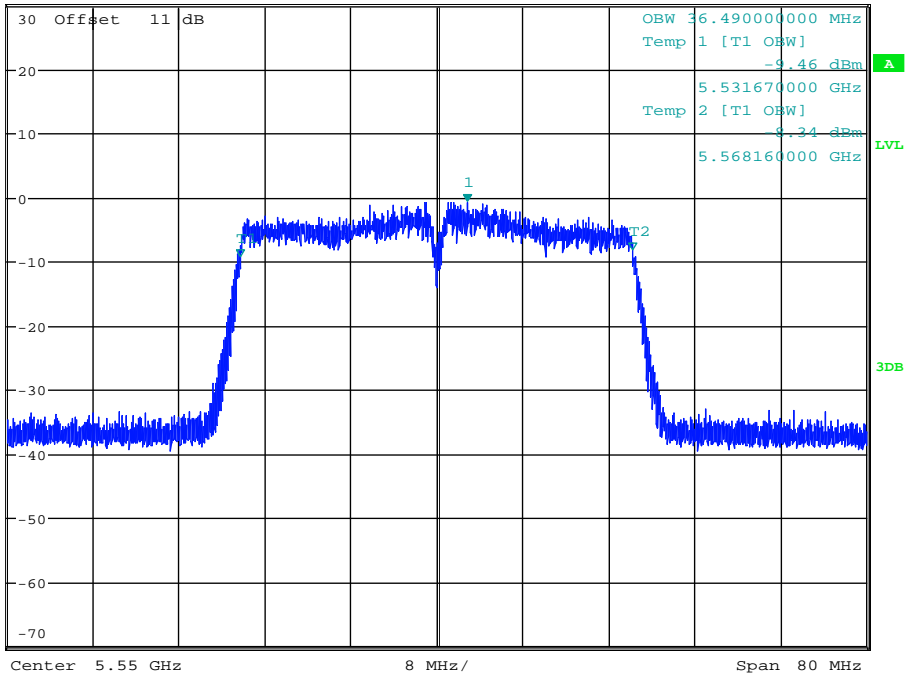

Date: 2.JAN.2018 14:04:47

### Occupied Bandwidth Measurement\_11AC40SISO\_5550\_Ant2



\*RBW 500 kHz      Marker 1 [T1 ]  
\*VBW 1 MHz      -0.09 dBm  
Ref 30 dBm      \*Att 40 dB      SWT 35 ms      5.555690000 GHz

1 PK  
VIEW

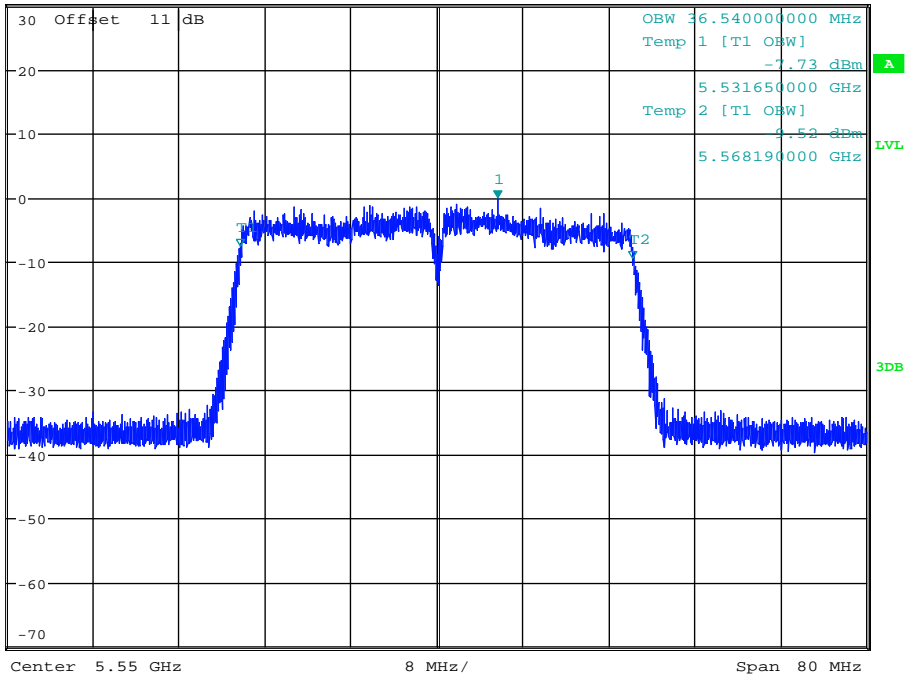

Date: 3.JAN.2018 17:11:46

### Occupied Bandwidth Measurement\_11AC40SISO\_5670\_Ant1

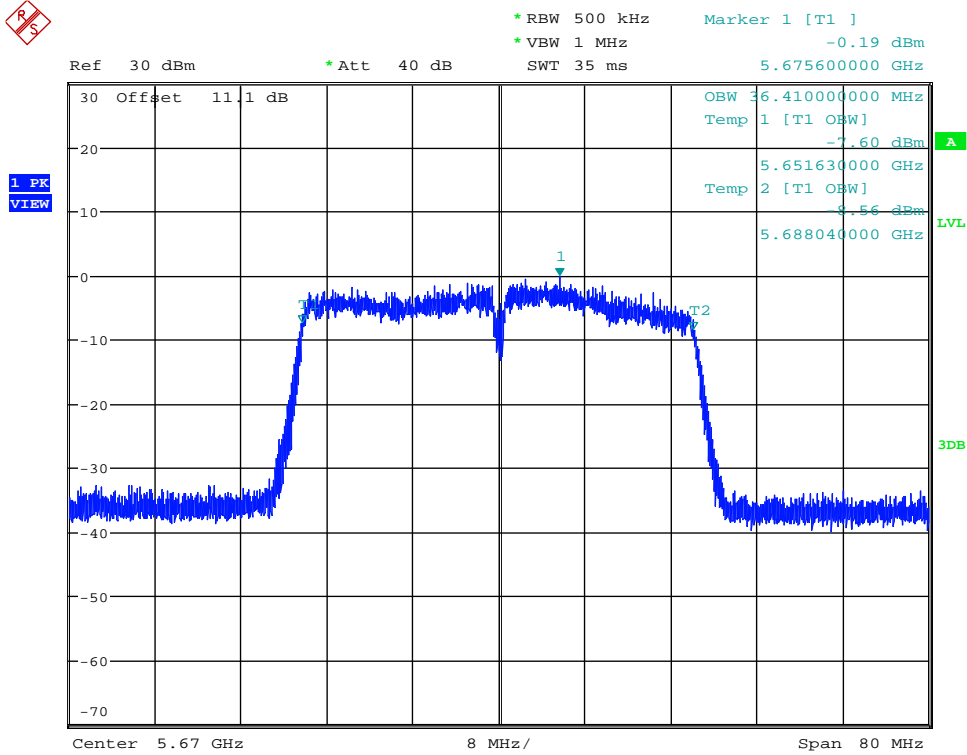

Date: 2.JAN.2018 14:09:12

### Occupied Bandwidth Measurement\_11AC40SISO\_5670\_Ant2

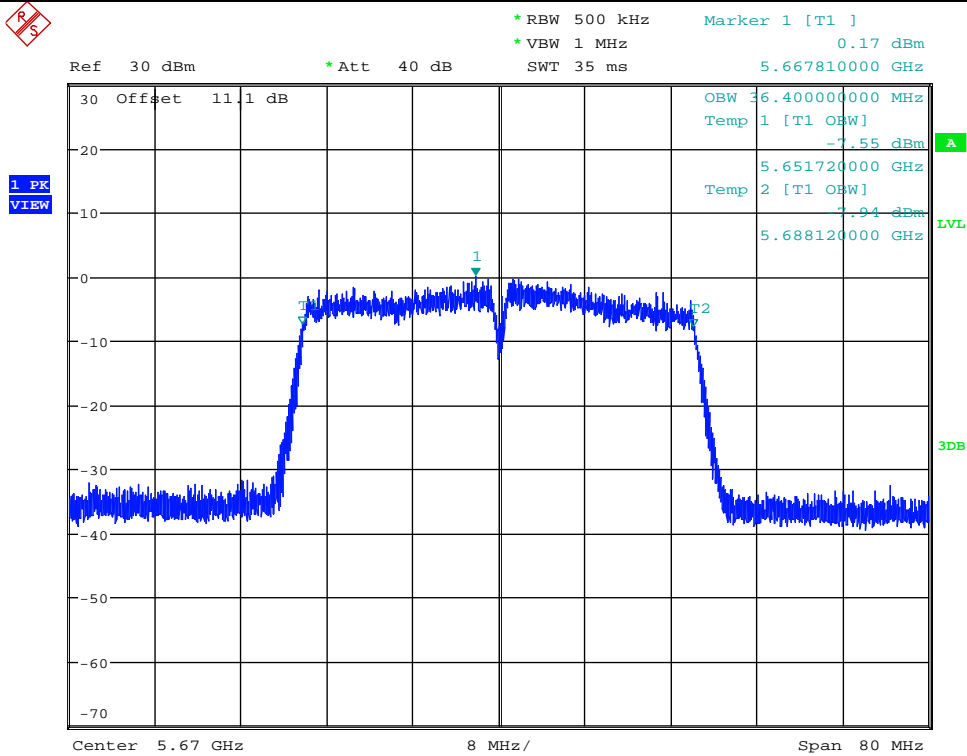

Date: 3.JAN.2018 17:16:14

### Occupied Bandwidth Measurement\_11AC40SISO\_5755\_Ant1



Ref 30 dBm      \* Att 40 dB      \* RBW 100 kHz      Marker 1 [T1 ]  
\* VBW 300 kHz      -4.84 dBm  
SWT 35 ms      5.758750000 GHz

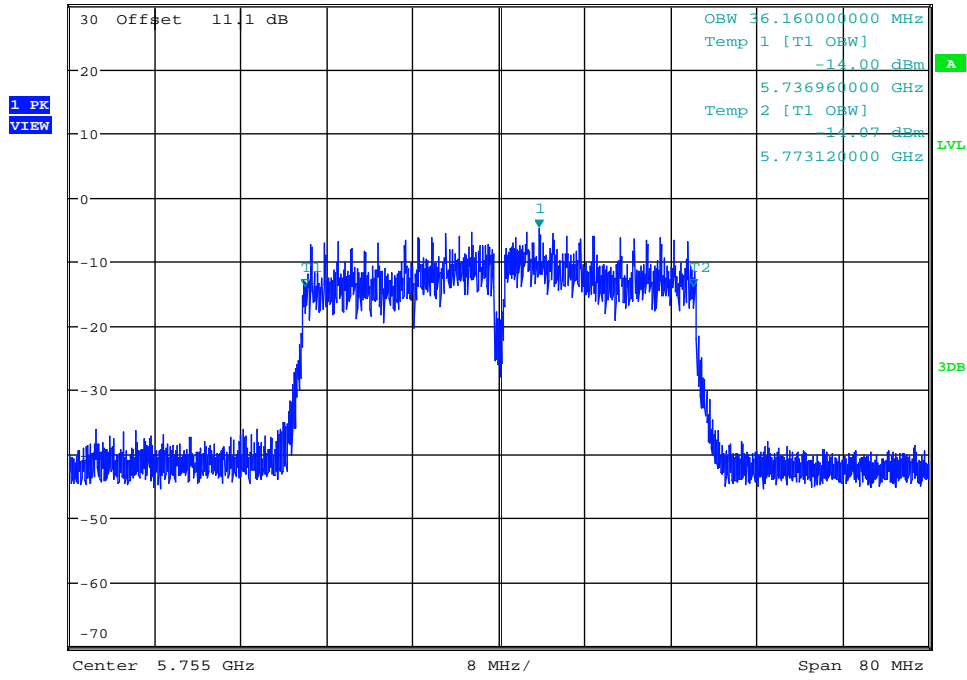

Date: 2.JAN.2018 14:15:34

### Occupied Bandwidth Measurement\_11AC40SISO\_5755\_Ant2



Ref 30 dBm      \* Att 40 dB      \* RBW 100 kHz      Marker 1 [T1 ]  
\* VBW 300 kHz      -5.12 dBm  
SWT 35 ms      5.758770000 GHz

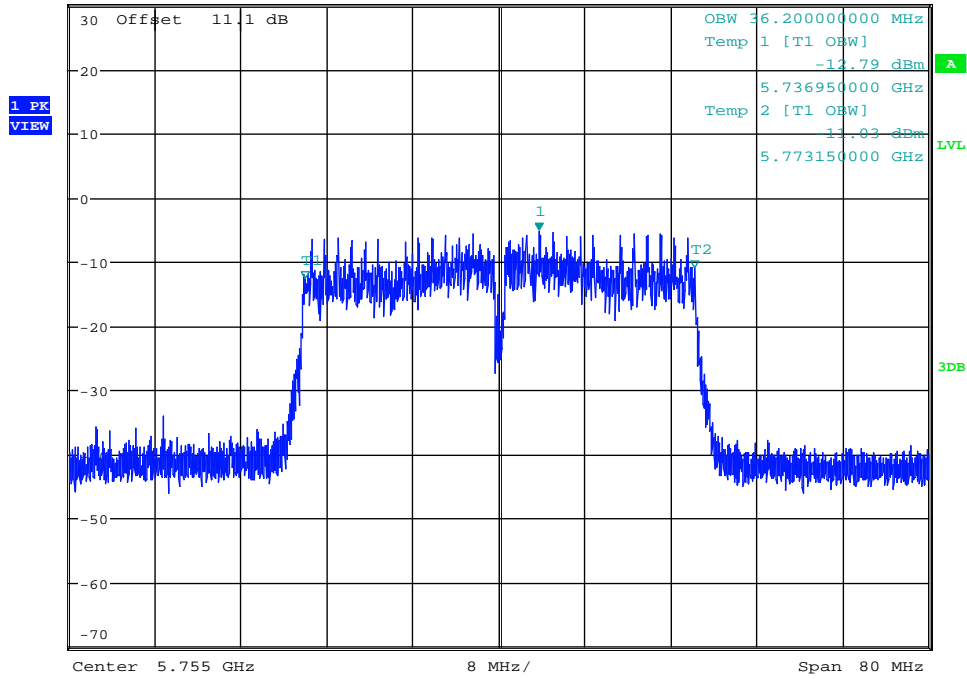

Date: 3.JAN.2018 17:21:30

### Occupied Bandwidth Measurement\_11AC40SISO\_5795\_Ant1

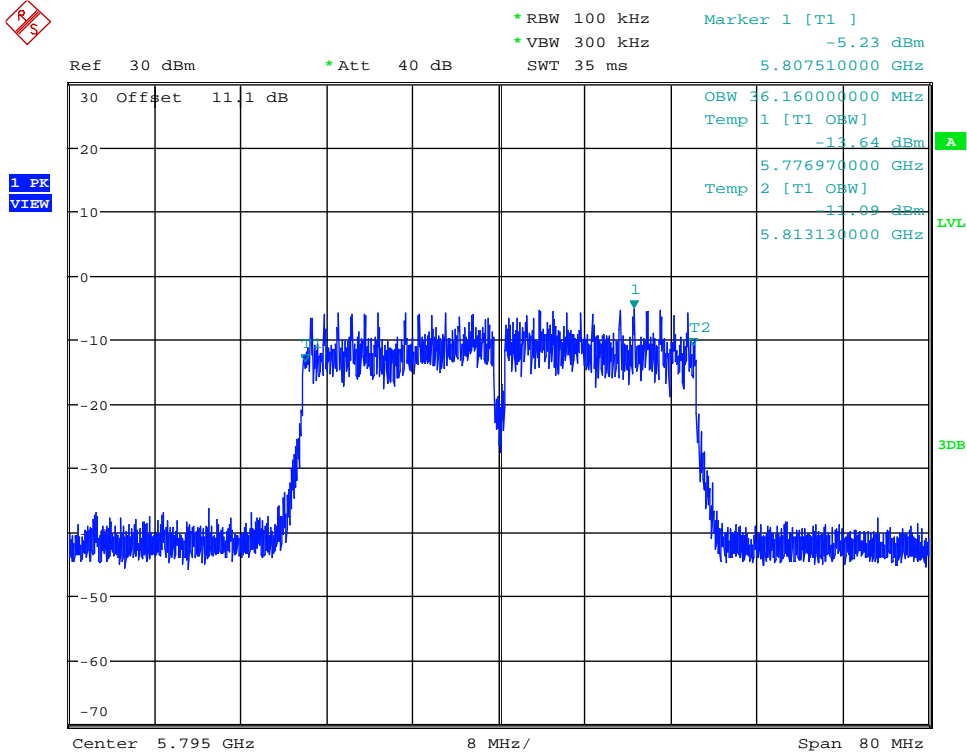

Date: 2.JAN.2018 14:24:46

### Occupied Bandwidth Measurement\_11AC40SISO\_5795\_Ant2

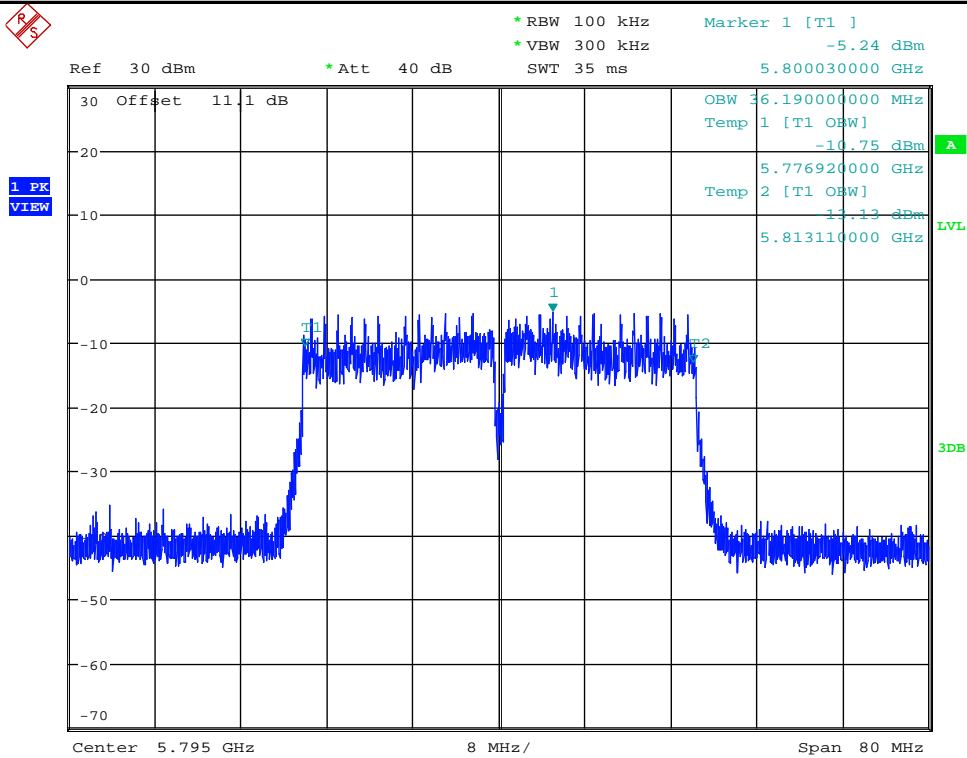

Date: 3.JAN.2018 17:26:31

### Occupied Bandwidth Measurement\_11AC80SISO\_5210\_Ant1

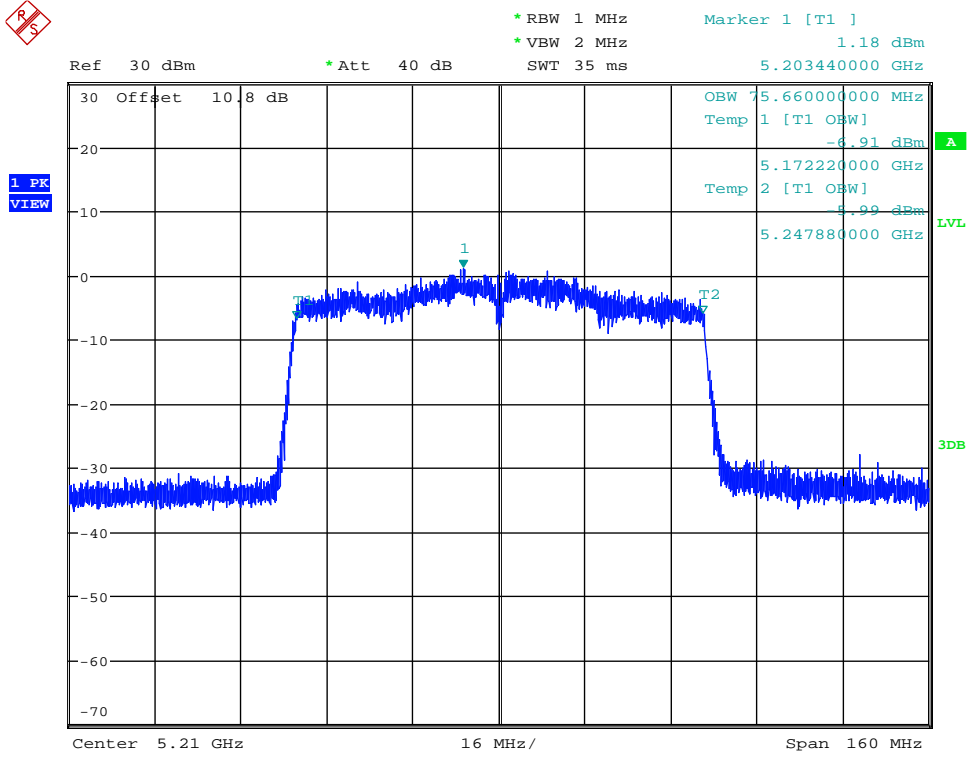

Date: 2.JAN.2018 14:29:45

### Occupied Bandwidth Measurement\_11AC80SISO\_5210\_Ant2

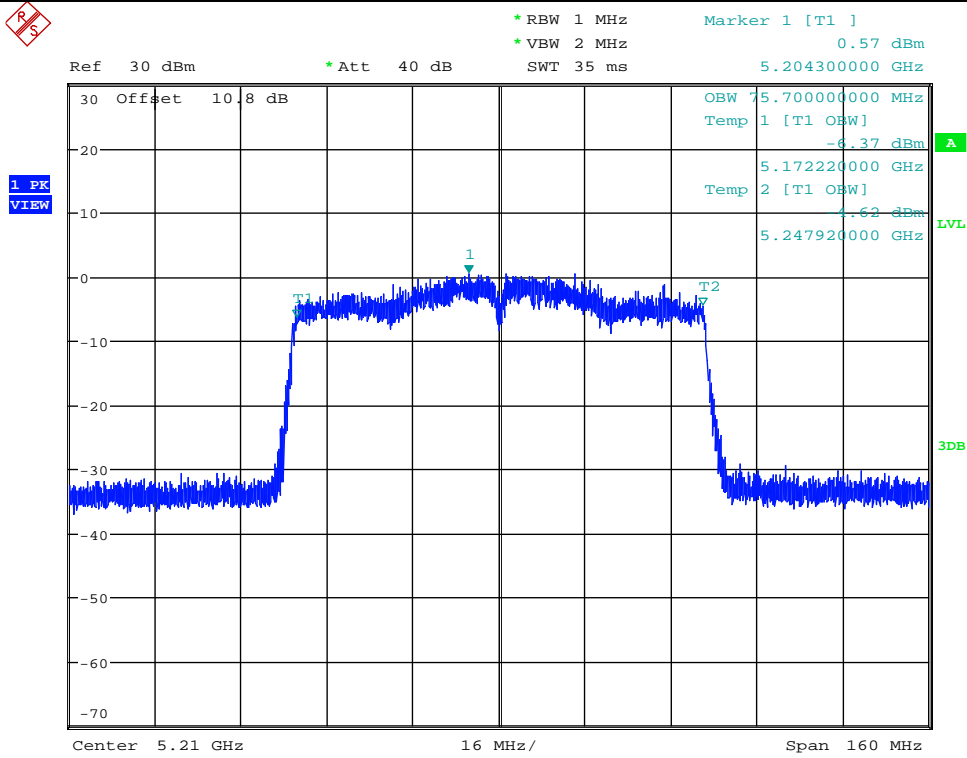

Date: 3.JAN.2018 17:32:16

### Occupied Bandwidth Measurement\_11AC80SISO\_5290\_Ant1



Ref 30 dBm      \* Att 40 dB      \* RBW 1 MHz      \* VBW 2 MHz      Marker 1 [T1 ]  
SWT 35 ms      5.288480000 GHz      1.23 dBm

1 PK VIEW

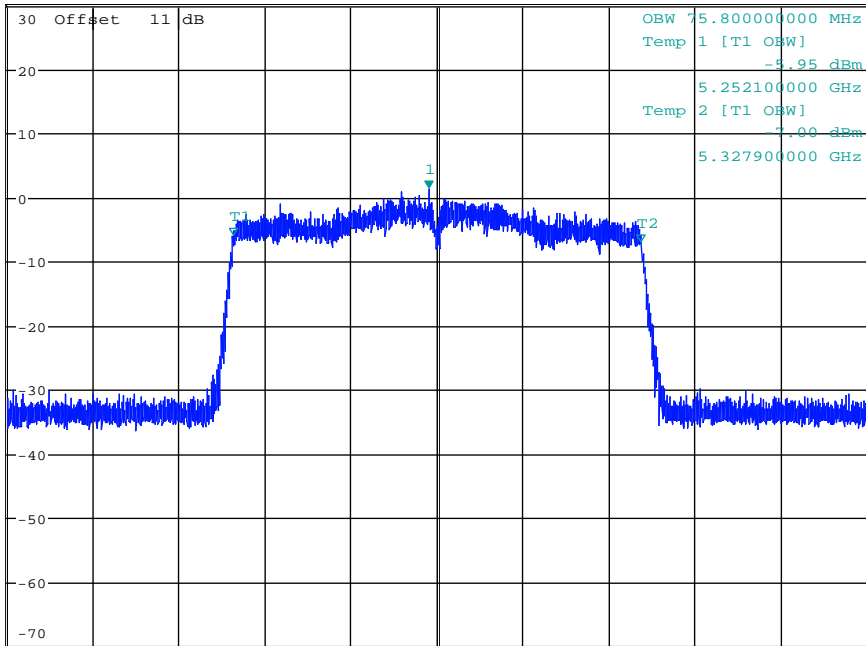

Center 5.29 GHz      16 MHz/      Span 160 MHz

Date: 2.JAN.2018 14:35:47

### Occupied Bandwidth Measurement\_11AC80SISO\_5290\_Ant2



Ref 30 dBm      \* Att 40 dB      \* RBW 1 MHz      \* VBW 2 MHz      Marker 1 [T1 ]  
SWT 35 ms      5.287940000 GHz      1.02 dBm

1 PK VIEW

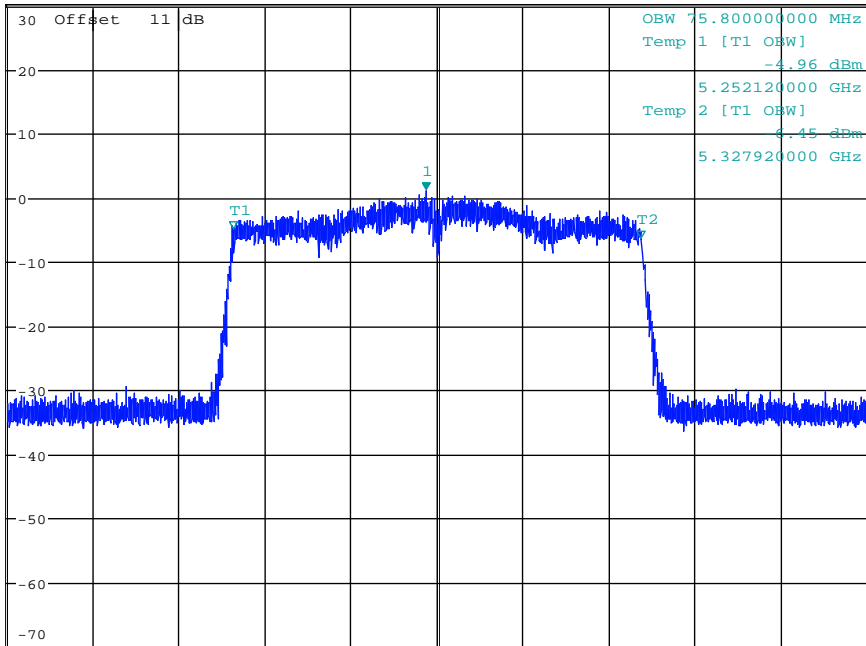

Center 5.29 GHz      16 MHz/      Span 160 MHz

Date: 3.JAN.2018 17:38:23

### Occupied Bandwidth Measurement\_11AC80SISO\_5530\_Ant1

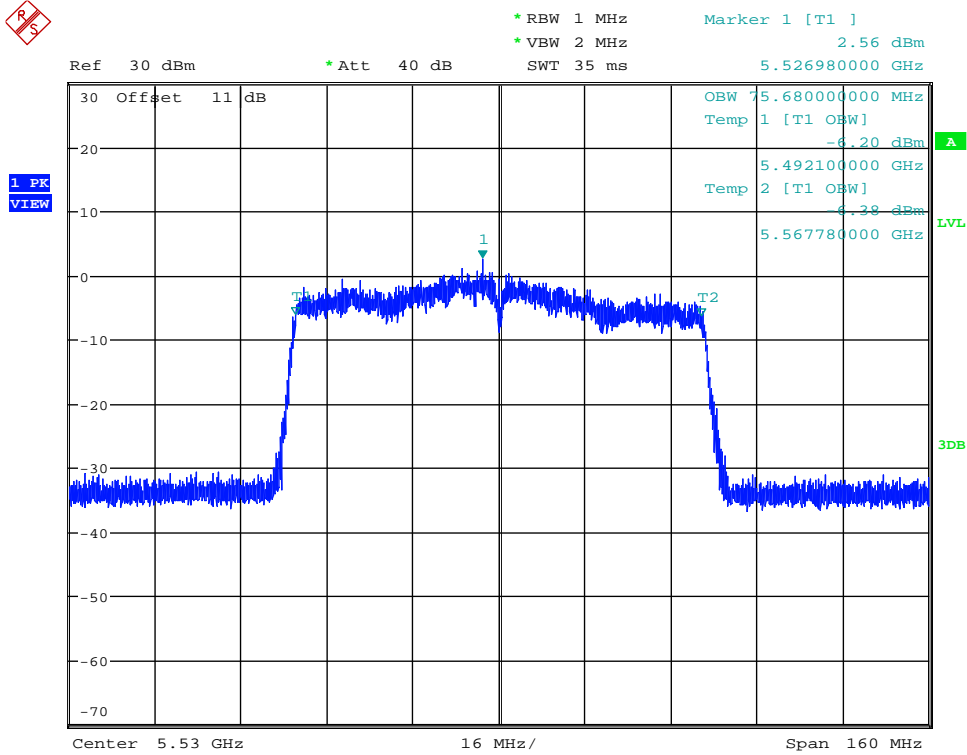

Date: 2.JAN.2018 14:42:55

### Occupied Bandwidth Measurement\_11AC80SISO\_5530\_Ant2

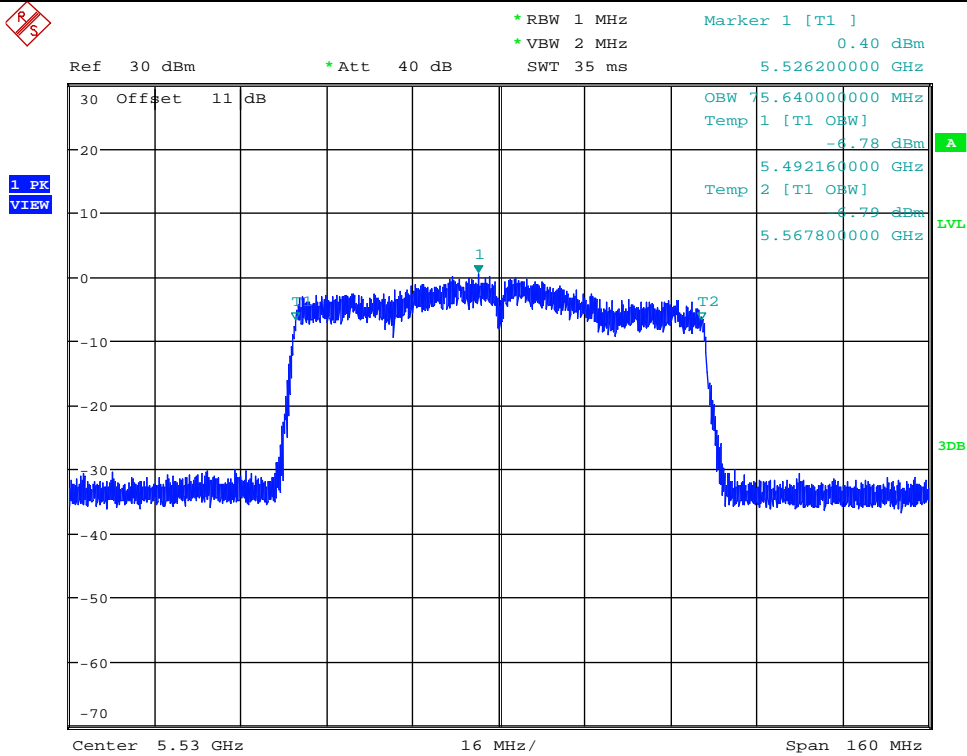

Date: 3.JAN.2018 17:46:33

### Occupied Bandwidth Measurement\_11AC80SISO\_5775\_Ant1



Ref 30 dBm      \* Att 40 dB      \* RBW 100 kHz      Marker 1 [T1 ]  
\* VBW 300 kHz      -7.99 dBm  
SWT 35 ms      5.786280000 GHz

1 PK  
VIEW

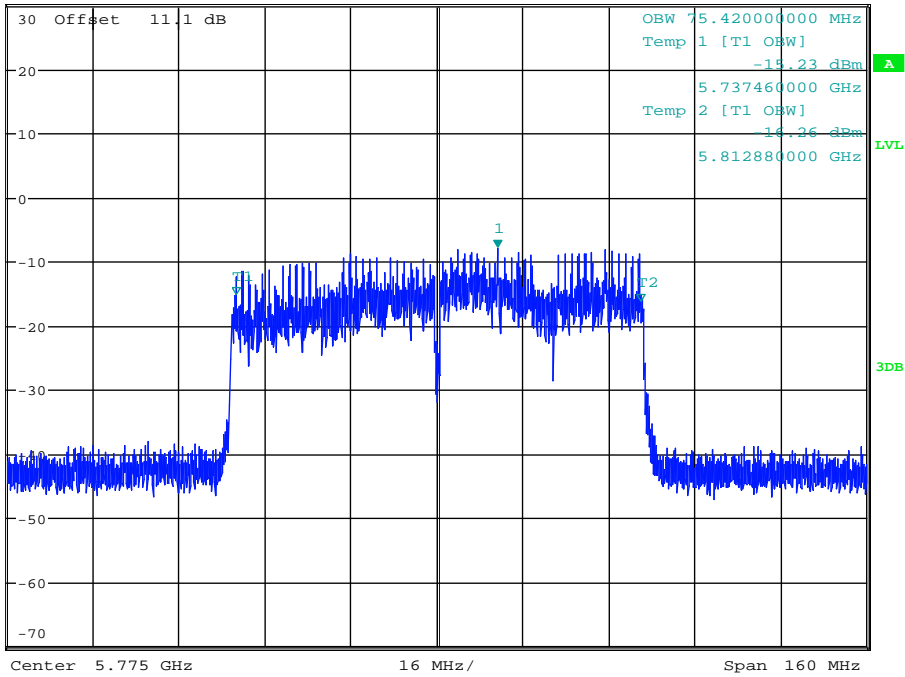

Date: 2.JAN.2018 14:49:09

### Occupied Bandwidth Measurement\_11AC80SISO\_5775\_Ant2



Ref 30 dBm      \* Att 40 dB      \* RBW 100 kHz      Marker 1 [T1 ]  
\* VBW 300 kHz      -8.01 dBm  
SWT 35 ms      5.786300000 GHz

1 PK  
VIEW

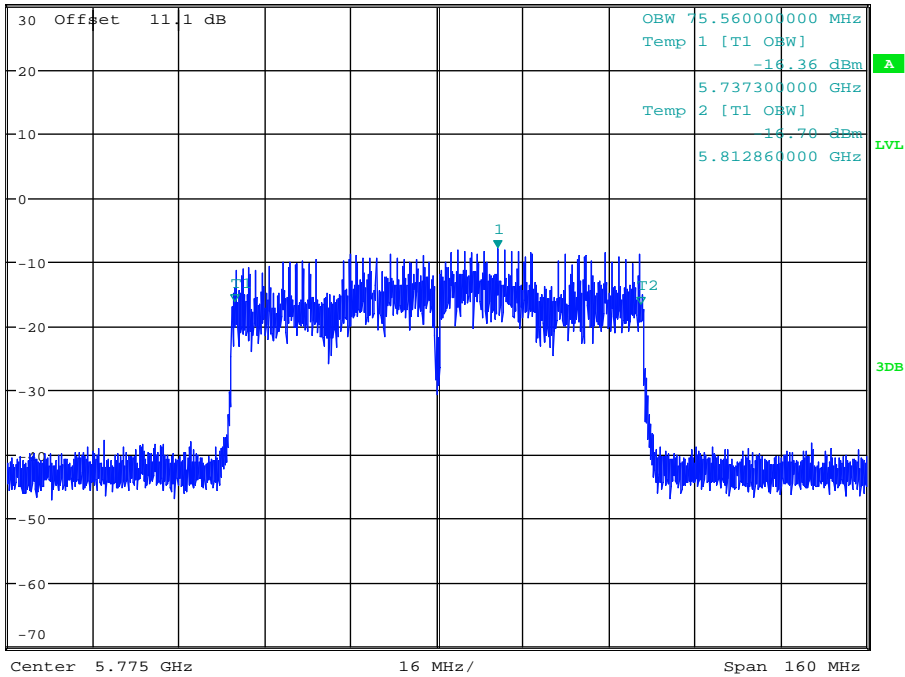

Date: 3.JAN.2018 17:53:27

## 6. Maximum Output Power

### 6.1. Block diagram of test setup

Same as scetion 4.1

### 6.2. Limits

FCC Part15, Subpart E/ RSS-247		
Test Item	Limit	Frequency Range (MHz)
Conducted Output Power	For FCC client devices :250mW (24dBm)	5150-5250
	For RSS:e.i.r.p. power: not exceed 200 mW(23dBm) or $10 + 10 \log_{10} B$	
	250mW (24dBm) or $11 + 10 \log_{10} B$	5250-5350
	250mW (24dBm) or $11 + 10 \log_{10} B$	For FCC:5470-5725 For IC:5470-5600 5650-5725
	1 Watt (30dBm)	5725-5850
Note: For FCC: B=26dB bandwidth, ISED: B=99% bandwidth.		

### 6.3. Test Procedure

- (1) Connect each EUT's antenna output to power sensor by RF cable and attenuator
- (2) Add each antenna port's results to get the total output power of EUT.

### 6.4. Test Result

(5150-5250)

Test Mode	Test Channel	Ant	Level [dBm]	$10\log(1/x)$ Factor [dB]	Ouput Power [dBm]	EIRP [dBm]	FCC LIMIT	ISED LIMIT ( $10 + 10 \log_{10} B$ )
11A	5180	Ant1	13.46	2.03	15.49	19.85	23.98	22.15
11A	5180	Ant2	12.98	2.06	15.04	19.08	23.98	22.15
11A	5200	Ant1	12.73	2.03	14.76	19.12	23.98	22.15
11A	5200	Ant2	13.54	2.03	15.57	19.61	23.98	22.15
11A	5240	Ant1	13.22	2.03	15.25	19.61	23.98	22.15
11A	5240	Ant2	12.68	2.03	14.71	18.75	23.98	22.15
11N20	5180	Ant1	13.49	2.16	15.65	20.01	23.98	22.15
11N20	5180	Ant2	12.42	2.16	14.58	18.62	23.98	22.15
11N20	5200	Ant1	12.63	2.16	14.79	19.15	23.98	22.15
11N20	5200	Ant2	12.82	2.14	14.96	19.0	23.98	22.15
11N20	5240	Ant1	13.06	2.16	15.22	19.58	23.98	22.15
11N20	5240	Ant2	11.77	2.16	13.93	17.97	23.98	22.15

11N40	5190	Ant1	12.32	3.2	15.52	19.88	23.98	22.15
11N40	5190	Ant2	12.25	3.15	15.4	19.44	23.98	22.15
11N40	5230	Ant1	11.96	3.15	15.11	19.47	23.98	22.15
11N40	5230	Ant2	12.2	3.15	15.35	19.39	23.98	22.15
11AC20	5180	Ant1	12.67	2.12	14.79	19.15	23.98	22.15
11AC20	5180	Ant2	11.94	2.12	14.06	18.1	23.98	22.15
11AC20	5200	Ant1	12.25	2.12	14.37	18.73	23.98	22.15
11AC20	5200	Ant2	12.48	2.11	14.59	18.63	23.98	22.15
11AC20	5240	Ant1	12.59	2.12	14.71	19.07	23.98	22.15
11AC20	5240	Ant2	12.02	2.11	14.13	18.17	23.98	22.15
11AC40	5190	Ant1	9.96	3.43	13.39	17.75	23.98	22.15
11AC40	5190	Ant2	9.59	3.43	13.02	17.06	23.98	22.15
11AC40	5230	Ant1	9.12	3.43	12.55	16.91	23.98	22.15
11AC40	5230	Ant2	9.66	3.43	13.09	17.13	23.98	22.15
11AC80	5210	Ant1	9.02	4.3	13.32	17.68	23.98	22.15
11AC80	5210	Ant2	8.96	4.3	13.26	17.3	23.98	22.15
Verdict: PASS								

**(5250-5350, 5470-5725, 5725-5850)**

Test Mode	Test Channel	Ant	Level [dBm]	10log(1/x) Factor [dB]	Power [dBm]	Limit [dBm]	Verdict
11A	5260	Ant1	12.9	2.03	14.93	23.98	PASS
11A	5260	Ant2	13.32	2.03	15.35	23.98	PASS
11A	5280	Ant1	12.97	2.03	15	23.98	PASS
11A	5280	Ant2	13.59	2.05	15.64	23.98	PASS
11A	5320	Ant1	13.79	2.06	15.85	23.98	PASS
11A	5320	Ant2	14.05	2.03	16.08	23.98	PASS
11A	5500	Ant1	13.7	2.06	15.76	23.98	PASS
11A	5500	Ant2	13.16	2.03	15.19	23.98	PASS
11A	5580	Ant1	12.56	2.03	14.59	23.98	PASS
11A	5580	Ant2	12.33	2.03	14.36	23.98	PASS
11A	5700	Ant1	12.53	2.03	14.56	23.98	PASS
11A	5700	Ant2	12.69	2.03	14.72	23.98	PASS
11A	5745	Ant1	12.65	2.05	14.7	30	PASS
11A	5745	Ant2	13.24	2.03	15.27	30	PASS
11A	5785	Ant1	13.91	2.03	15.94	30	PASS
11A	5785	Ant2	13.98	2.03	16.01	30	PASS
11A	5825	Ant1	13.78	2.05	15.83	30	PASS
11A	5825	Ant2	13.42	2.03	15.45	30	PASS
11N20	5260	Ant1	8.43	2.16	10.59	23.98	PASS

11N20	5260	Ant2	8.76	2.16	10.92	23.98	PASS
11N20	5280	Ant1	8.34	2.16	10.5	23.98	PASS
11N20	5280	Ant2	9.23	2.16	11.39	23.98	PASS
11N20	5320	Ant1	9.53	2.16	11.69	23.98	PASS
11N20	5320	Ant2	9.83	2.16	11.99	23.98	PASS
11N20	5500	Ant1	12.44	2.16	14.6	23.98	PASS
11N20	5500	Ant2	11.98	2.16	14.14	23.98	PASS
11N20	5580	Ant1	11.51	2.16	13.67	23.98	PASS
11N20	5580	Ant2	10.94	2.16	13.1	23.98	PASS
11N20	5700	Ant1	11.37	2.16	13.53	23.98	PASS
11N20	5700	Ant2	11.61	2.16	13.77	23.98	PASS
11N20	5745	Ant1	11.3	2.18	13.48	30	PASS
11N20	5745	Ant2	11.93	2.16	14.09	30	PASS
11N20	5785	Ant1	12.67	2.16	14.83	30	PASS
11N20	5785	Ant2	12.57	2.16	14.73	30	PASS
11N20	5825	Ant1	12.13	2.16	14.29	30	PASS
11N20	5825	Ant2	12.08	2.16	14.24	30	PASS
11N40	5270	Ant1	10.45	3.15	13.6	23.98	PASS
11N40	5270	Ant2	10.76	3.15	13.91	23.98	PASS
11N40	5310	Ant1	11.35	3.15	14.5	23.98	PASS
11N40	5310	Ant2	11.47	3.15	14.62	23.98	PASS
11N40	5510	Ant1	12.08	3.15	15.23	23.98	PASS
11N40	5510	Ant2	11.63	3.15	14.78	23.98	PASS
11N40	5550	Ant1	10.91	3.15	14.06	23.98	PASS
11N40	5550	Ant2	10.92	3.15	14.07	23.98	PASS
11N40	5670	Ant1	10.88	3.15	14.03	23.98	PASS
11N40	5670	Ant2	11.09	3.15	14.24	23.98	PASS
11N40	5755	Ant1	11.78	3.15	14.93	30	PASS
11N40	5755	Ant2	11.95	3.15	15.1	30	PASS
11N40	5795	Ant1	12.49	3.18	15.67	30	PASS
11N40	5795	Ant2	12.5	3.15	15.65	30	PASS
11AC20	5260	Ant1	8.35	2.12	10.47	23.98	PASS
11AC20	5260	Ant2	8.49	2.11	10.6	23.98	PASS
11AC20	5280	Ant1	8.54	2.11	10.65	23.98	PASS
11AC20	5280	Ant2	8.93	2.12	11.05	23.98	PASS
11AC20	5320	Ant1	9.61	2.12	11.73	23.98	PASS
11AC20	5320	Ant2	9.89	2.12	12.01	23.98	PASS
11AC20	5500	Ant1	12.63	2.14	14.77	23.98	PASS
11AC20	5500	Ant2	11.55	2.12	13.67	23.98	PASS
11AC20	5580	Ant1	11.42	2.11	13.53	23.98	PASS

11AC20	5580	Ant2	11.04	2.14	13.18	23.98	PASS
11AC20	5700	Ant1	11.93	2.14	14.07	23.98	PASS
11AC20	5700	Ant2	11.22	2.12	13.34	23.98	PASS
11AC20	5745	Ant1	11.38	2.12	13.5	30	PASS
11AC20	5745	Ant2	12.01	2.11	14.12	30	PASS
11AC20	5785	Ant1	12.57	2.12	14.69	30	PASS
11AC20	5785	Ant2	12.72	2.11	14.83	30	PASS
11AC20	5825	Ant1	12.16	2.12	14.28	30	PASS
11AC20	5825	Ant2	12.25	2.12	14.37	30	PASS
11AC40	5270	Ant1	8.34	3.46	11.8	23.98	PASS
11AC40	5270	Ant2	8.53	3.46	11.99	23.98	PASS
11AC40	5310	Ant1	9.17	3.49	12.66	23.98	PASS
11AC40	5310	Ant2	9.41	3.46	12.87	23.98	PASS
11AC40	5510	Ant1	9.81	3.43	13.24	23.98	PASS
11AC40	5510	Ant2	8.94	3.46	12.4	23.98	PASS
11AC40	5550	Ant1	8.19	3.46	11.65	23.98	PASS
11AC40	5550	Ant2	8.26	3.49	11.75	23.98	PASS
11AC40	5670	Ant1	8.36	3.46	11.82	23.98	PASS
11AC40	5670	Ant2	8.68	3.46	12.14	23.98	PASS
11AC40	5755	Ant1	9.61	3.46	13.07	30	PASS
11AC40	5755	Ant2	9.78	3.46	13.24	30	PASS
11AC40	5795	Ant1	10.11	3.4	13.51	30	PASS
11AC40	5795	Ant2	9.99	3.43	13.42	30	PASS
11AC80	5290	Ant1	8.63	4.3	12.93	23.98	PASS
11AC80	5290	Ant2	8.82	4.3	13.12	23.98	PASS
11AC80	5530	Ant1	8.65	4.3	12.95	23.98	PASS
11AC80	5530	Ant2	8.45	4.3	12.75	23.98	PASS
11AC80	5775	Ant1	9.4	4.3	13.7	30	PASS
11AC80	5775	Ant2	9.5	4.3	13.8	30	PASS

## 7. Power Spectral Density

### 7.1. Block diagram of test setup

Same with 4.1

### 7.2. Limits

FCC Part15, Subpart E/ RSS-247		
Test Item	Limit	Frequency Range (MHz)
Power Spectral Density	For FCC: Other then Mobile and portable:17dBm/MHz Mobile and portable:11dBm/MHz	5150-5250
	For RSS eirp:10dBm/MHz	
	11dBm/MHz	5250-5350
	11dBm/MHz	For FCC:5470-5725 For IC:5470-5600 5650-5725
	30dBm/500kHz	5725-5850

### 7.3. Test Procedure

The transmitter output was connected to a spectrum analyzer. Power density was measured by spectrum analyzer with 1MHz RBW and 3MHz VBW.

Connect the UUT to the spectrum analyser and use the following settings:

5150MHz~5250MHz,5250MHz~5350MHz,5470MHz~5725MHz

Center Frequency	The centre frequency of the channel under test
Detector	RMS
RBW	1MHz
VBW	$\geq 3 \times \text{RBW}$
Span	Encompass the entire emissions bandwidth (EBW) of the signal
Trace	Max hold
Sweep time	Auto

5725MHz-5850MHz

Center Frequency	The centre frequency of the channel under test
Detector	RMS
RBW	500KHz
VBW	$\geq 3 \times \text{RBW}$
Span	Encompass the entire emissions bandwidth (EBW) of the signal
Trace	Max hold
Sweep time	Auto

## Note:

1. For UNII-3, according to KDB publication 789033 D02 General UNII Test Procedures New Rules v01, section II.F.5., it is acceptable to set RBW at 1MHz and VBW at 3MHz if the spectrum analyzer does not have 500kHz RBW.
2. The value measured with RBW=1MHz is to be added with  $10\log(500\text{kHz}/1\text{MHz})$  which is - 3dB. For example, if the measured value is +10dBm using RBW=1MHz (that is +10dBm/MHz), then the converted value will be +7dBm/500kHz.

Allow trace to fully stabilize and use the peak marker function to determine the maximum amplitude level within the RBW.

## 7.4. Test Result

### (5150-5250)

Test Mode	Test Channel	Ant	Level [dBm/MHz]	$10\log(1/x)$ Factor [dB]	PSD [dBm/MHz]	PSD eirp [dBm/MHz]	FCC Limit [dBm/MHz]	ISED Limit [dBm/MHz]
11A	5180	Ant1	3.37	2.03	5.40	9.76	11.00	10.00
11A	5180	Ant2	3.32	2.06	5.38	9.42	11.00	10.00
11A	5200	Ant1	2.94	2.03	4.97	9.33	11.00	10.00
11A	5200	Ant2	3.84	2.03	5.87	9.91	11.00	10.00
11A	5240	Ant1	3.43	2.03	5.46	9.82	11.00	10.00
11A	5240	Ant2	2.74	2.03	4.77	8.81	11.00	10.00
11N20	5180	Ant1	3.31	2.16	5.57	9.93	11.00	10.00
11N20	5180	Ant2	2.49	2.16	4.65	8.69	11.00	10.00
11N20	5200	Ant1	2.76	2.16	4.92	9.28	11.00	10.00
11N20	5200	Ant2	3.13	2.14	5.27	9.31	11.00	10.00
11N20	5240	Ant1	3.28	2.16	5.44	9.8	11.00	10.00
11N20	5240	Ant2	1.76	2.16	3.92	7.96	11.00	10.00
11N40	5190	Ant1	-0.65	3.2	2.55	6.91	11.00	10.00
11N40	5190	Ant2	-0.49	3.15	2.66	6.7	11.00	10.00
11N40	5230	Ant1	-0.75	3.15	2.4	6.76	11.00	10.00
11N40	5230	Ant2	-0.6	3.15	2.55	6.59	11.00	10.00
11AC20	5180	Ant1	3.18	2.11	5.29	9.65	11.00	10.00
11AC20	5180	Ant2	2.36	2.12	4.48	8.52	11.00	10.00
11AC20	5200	Ant1	2.65	2.12	4.77	9.13	11.00	10.00
11AC20	5200	Ant2	2.61	2.11	4.72	8.76	11.00	10.00
11AC20	5240	Ant1	2.84	2.12	4.96	9.32	11.00	10.00
11AC20	5240	Ant2	2.41	2.11	4.52	8.56	11.00	10.00
11AC40	5190	Ant1	-2.86	3.43	0.57	4.93	11.00	10.00
11AC40	5190	Ant2	-3.39	3.43	0.04	4.08	11.00	10.00
11AC40	5230	Ant1	-3.27	3.43	0.16	4.52	11.00	10.00
11AC40	5230	Ant2	-2.93	3.43	0.5	4.54	11.00	10.00
11AC80	5210	Ant1	-6.87	4.3	-2.57	1.79	11.00	10.00

11AC80	5210	Ant2	-6.03	4.3	-1.73	2.31	11.00	10.00
--------	------	------	-------	-----	-------	------	-------	-------

**(5250-5350, 5470-5725, 5725-5850)**

Test Mode	Test Channel	Ant	Level [dBm/MHz]	10log(1/x) Factor [dB]	PSD [dBm/MHz]	Limit [dBm/MHz]	Verdict
11A	5260	Ant1	3.15	2.03	5.18	11	PASS
11A	5260	Ant2	3.56	2.03	5.59	11	PASS
11A	5280	Ant1	3.15	2.03	5.18	11	PASS
11A	5280	Ant2	3.82	2.05	5.87	11	PASS
11A	5320	Ant1	3.96	2.06	6.02	11	PASS
11A	5320	Ant2	4.24	2.03	6.27	11	PASS
11A	5500	Ant1	3.84	2.06	5.9	11	PASS
11A	5500	Ant2	3.44	2.03	5.47	11	PASS
11A	5580	Ant1	2.71	2.03	4.74	11	PASS
11A	5580	Ant2	2.64	2.03	4.67	11	PASS
11A	5700	Ant1	2.84	2.03	4.87	11	PASS
11A	5700	Ant2	3.16	2.03	5.19	11	PASS
11N20	5260	Ant1	-1.44	2.16	0.72	11	PASS
11N20	5260	Ant2	-0.93	2.16	1.23	11	PASS
11N20	5280	Ant1	-0.85	2.16	1.31	11	PASS
11N20	5280	Ant2	-0.19	2.16	1.97	11	PASS
11N20	5320	Ant1	-0.3	2.16	1.86	11	PASS
11N20	5320	Ant2	-0.05	2.16	2.11	11	PASS
11N20	5500	Ant1	2.75	2.16	4.91	11	PASS
11N20	5500	Ant2	2.17	2.16	4.33	11	PASS
11N20	5580	Ant1	1.76	2.16	3.92	11	PASS
11N20	5580	Ant2	1.07	2.16	3.23	11	PASS
11N20	5700	Ant1	1.62	2.16	3.78	11	PASS
11N20	5700	Ant2	1.84	2.16	4.0	11	PASS
11N40	5270	Ant1	-2.61	3.15	0.54	11	PASS
11N40	5270	Ant2	-1.27	3.15	1.88	11	PASS
11N40	5310	Ant1	-1.03	3.15	2.12	11	PASS
11N40	5310	Ant2	-0.94	3.15	2.21	11	PASS
11N40	5510	Ant1	-0.23	3.15	2.92	11	PASS
11N40	5510	Ant2	-0.78	3.15	2.37	11	PASS
11N40	5550	Ant1	-1.42	3.15	1.73	11	PASS
11N40	5550	Ant2	-1.71	3.15	1.44	11	PASS
11N40	5670	Ant1	-1.78	3.15	1.37	11	PASS
11N40	5670	Ant2	-1.64	3.15	1.51	11	PASS
11AC20	5260	Ant1	-1.53	2.12	0.59	11	PASS

11AC20	5260	Ant2	-1.36	2.11	0.75	11	PASS
11AC20	5280	Ant1	-1.48	2.11	0.63	11	PASS
11AC20	5280	Ant2	-0.46	2.12	1.66	11	PASS
11AC20	5320	Ant1	-0.22	2.12	1.9	11	PASS
11AC20	5320	Ant2	0.48	2.12	2.6	11	PASS
11AC20	5500	Ant1	2.94	2.14	5.08	11	PASS
11AC20	5500	Ant2	1.86	2.12	3.98	11	PASS
11AC20	5580	Ant1	1.5	2.11	3.61	11	PASS
11AC20	5580	Ant2	1.6	2.14	3.74	11	PASS
11AC20	5700	Ant1	2.63	2.14	4.77	11	PASS
11AC20	5700	Ant2	1.46	2.12	3.58	11	PASS
11AC40	5270	Ant1	-4.55	3.46	-1.09	11	PASS
11AC40	5270	Ant2	-4.04	3.46	-0.58	11	PASS
11AC40	5310	Ant1	-3.51	3.49	-0.02	11	PASS
11AC40	5310	Ant2	-3.34	3.46	0.12	11	PASS
11AC40	5510	Ant1	-3.05	3.43	0.38	11	PASS
11AC40	5510	Ant2	-3.82	3.46	-0.36	11	PASS
11AC40	5550	Ant1	-4.59	3.46	-1.13	11	PASS
11AC40	5550	Ant2	-4.49	3.49	-1.0	11	PASS
11AC40	5670	Ant1	-4.02	3.46	-0.56	11	PASS
11AC40	5670	Ant2	-4.07	3.46	-0.61	11	PASS
11AC80	5290	Ant1	-7.16	4.3	-2.86	11	PASS
11AC80	5290	Ant2	-7.12	4.3	-2.82	11	PASS
11AC80	5530	Ant1	-6.57	4.3	-2.27	11	PASS

Test Mode	Test Channel	Ant	Level [dBm/500 kHz]	10log(1/x) Factor[dB]	10log(500kHz/RBW) Factor [dB]	PSD [dBm/500kHz]	Limit [dBm/500kHz]	Verdict
11A	5745	Ant1	0.60	2.05	0.00	2.65	17.00	PASS
11A	5745	Ant2	1.27	2.03	0.00	3.30	17.00	PASS
11A	5785	Ant1	2.01	2.03	0.00	4.04	17.00	PASS
11A	5785	Ant2	1.96	2.03	0.00	3.99	17.00	PASS
11A	5825	Ant1	1.88	2.05	0.00	3.93	17.00	PASS
11A	5825	Ant2	1.34	2.03	0.00	3.37	17.00	PASS
11N20	5745	Ant1	-1.07	2.18	0.00	1.11	17.00	PASS
11N20	5745	Ant2	-0.48	2.16	0.00	1.68	17.00	PASS
11N20	5785	Ant1	0.65	2.16	0.00	2.81	17.00	PASS
11N20	5785	Ant2	0.37	2.16	0.00	2.53	17.00	PASS
11N20	5825	Ant1	0.18	2.16	0.00	2.34	17.00	PASS
11N20	5825	Ant2	0.33	2.16	0.00	2.49	17.00	PASS

11N40	5755	Ant1	-3.06	3.15	0.00	0.09	17.00	PASS
11N40	5755	Ant2	-2.68	3.15	0.00	0.47	17.00	PASS
11N40	5795	Ant1	-2.37	3.18	0.00	0.81	17.00	PASS
11N40	5795	Ant2	-2.61	3.15	0.00	0.54	17.00	PASS
11AC20	5745	Ant1	-0.59	2.12	0.00	1.53	17.00	PASS
11AC20	5745	Ant2	-0.12	2.11	0.00	1.99	17.00	PASS
11AC20	5785	Ant1	0.68	2.12	0.00	2.80	17.00	PASS
11AC20	5785	Ant2	0.93	2.11	0.00	3.04	17.00	PASS
11AC20	5825	Ant1	0.17	2.12	0.00	2.29	17.00	PASS
11AC20	5825	Ant2	0.63	2.12	0.00	2.75	17.00	PASS
11AC40	5755	Ant1	-4.61	3.46	0.00	-1.15	17.00	PASS
11AC40	5755	Ant2	-5.13	3.46	0.00	-1.67	17.00	PASS
11AC40	5795	Ant1	-5.21	3.40	0.00	-1.81	17.00	PASS
11AC40	5795	Ant2	-5.13	3.43	0.00	-1.70	17.00	PASS
11AC40	5775	Ant1	-7.83	4.30	0.00	-3.53	17.00	PASS
11AC40	5775	Ant2	-8.44	4.30	0.00	-4.14	17.00	PASS

7.5. Original test data

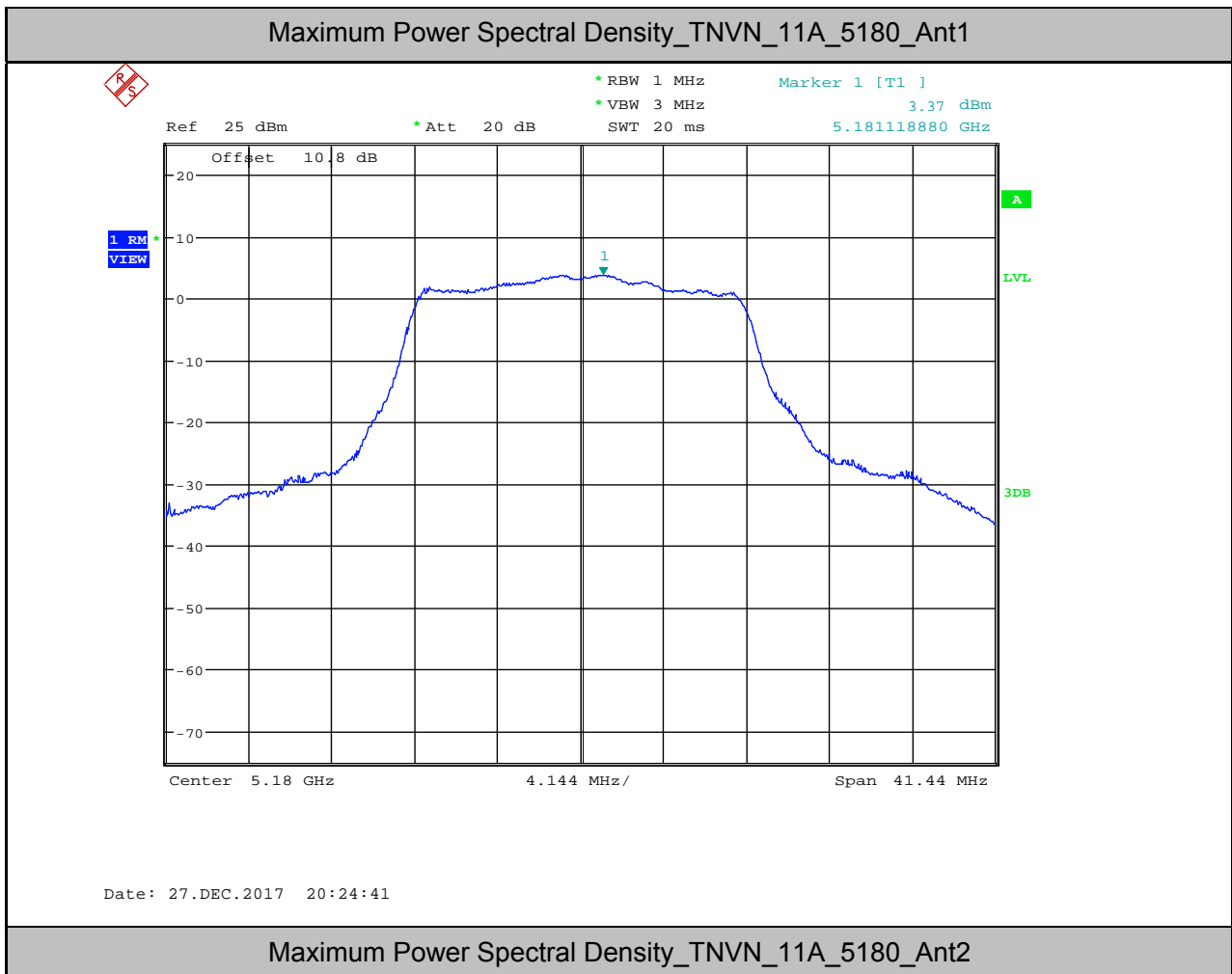

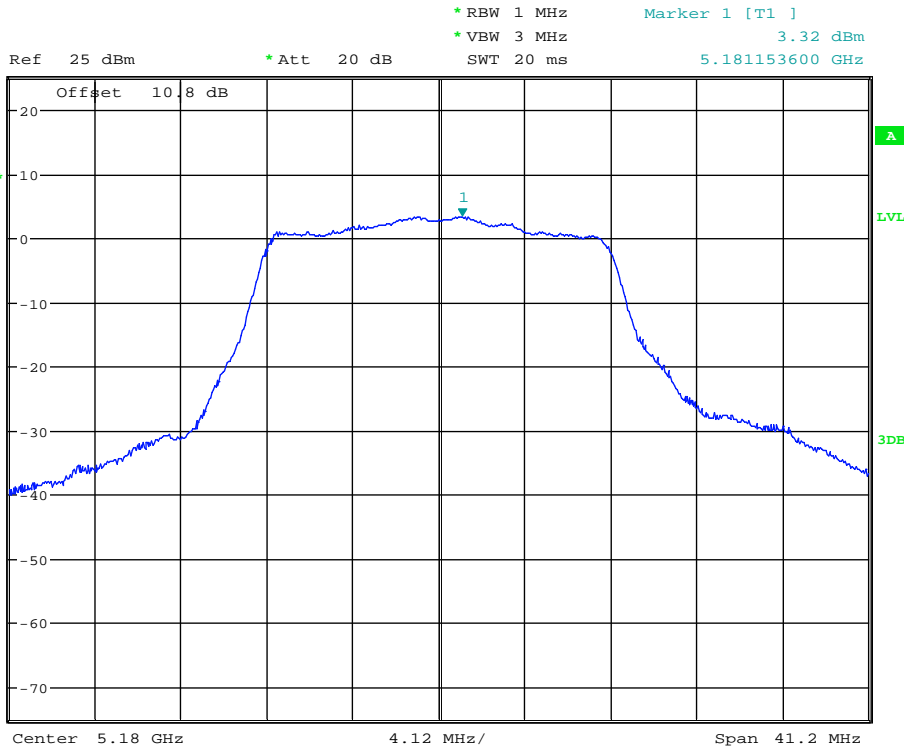

Date: 2.JAN.2018 14:57:45

Maximum Power Spectral Density\_TNVN\_11A\_5200\_Ant1

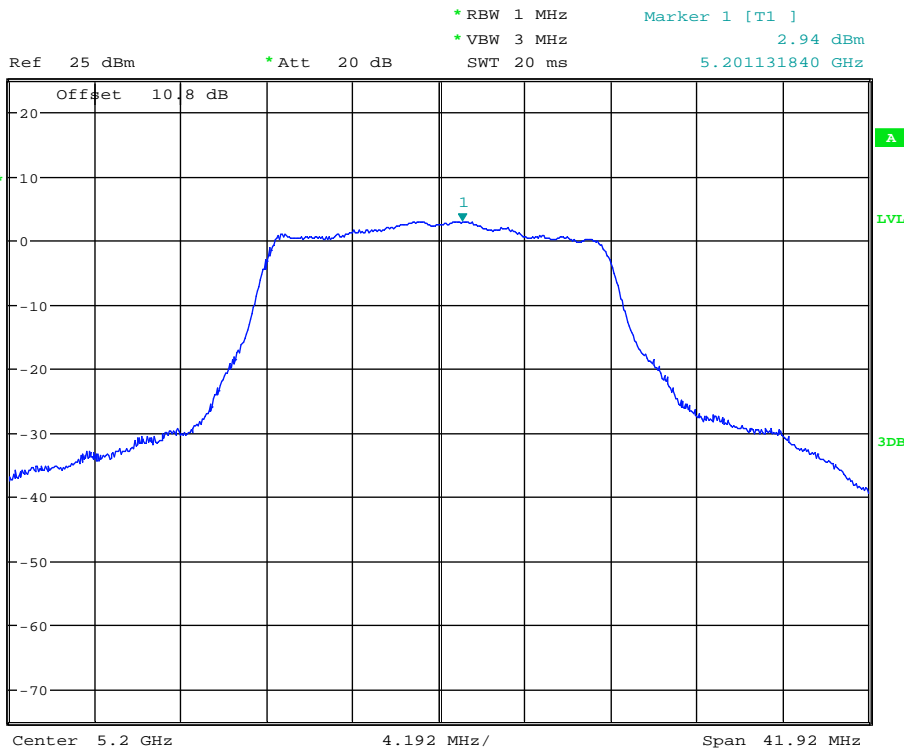

Date: 27.DEC.2017 20:29:56

Maximum Power Spectral Density\_TNVN\_11A\_5200\_Ant2

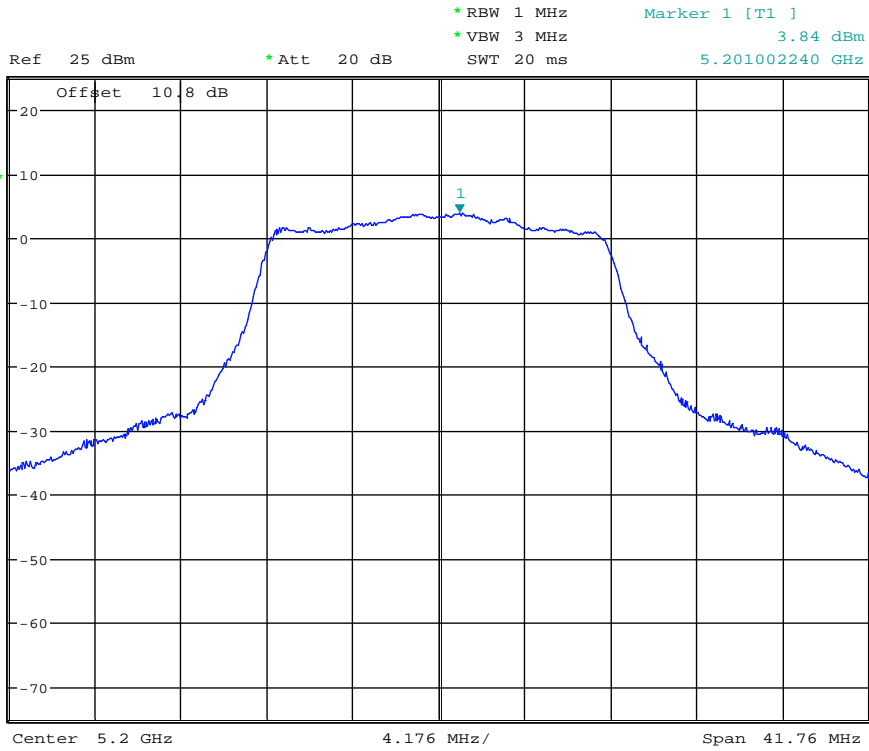

Date: 2.JAN.2018 15:03:21

Maximum Power Spectral Density\_TNVN\_11A\_5240\_Ant1

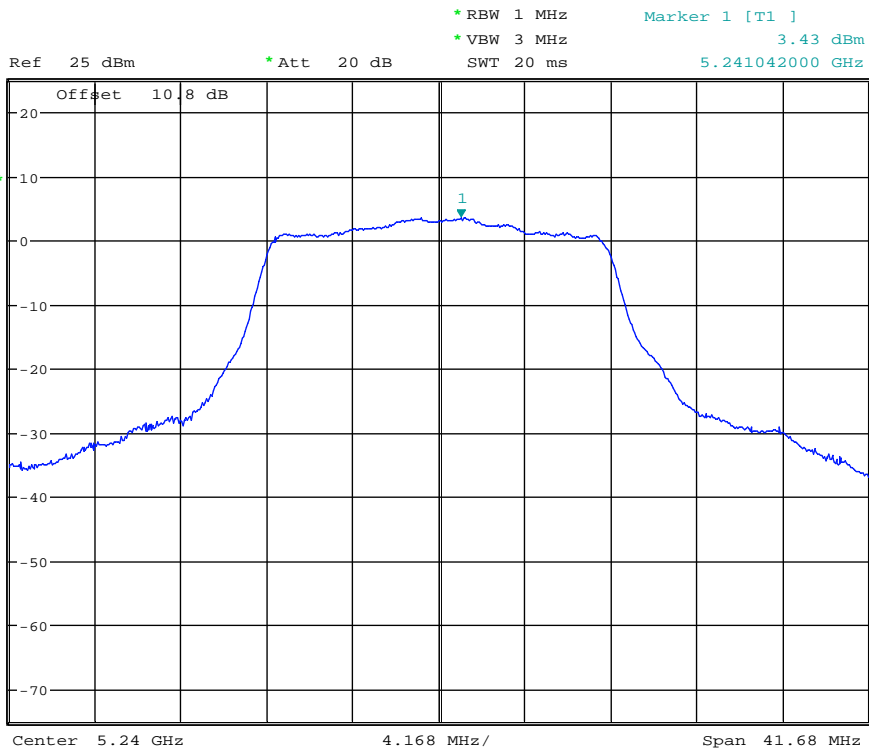

Date: 27.DEC.2017 20:35:02

Maximum Power Spectral Density\_TNVN\_11A\_5240\_Ant2



Ref 25 dBm      \* Att 20 dB      \* RBW 1 MHz      Marker 1 [T1 ]      2.74 dBm  
\* VBW 3 MHz      5.238880960 GHz  
SWT 20 ms

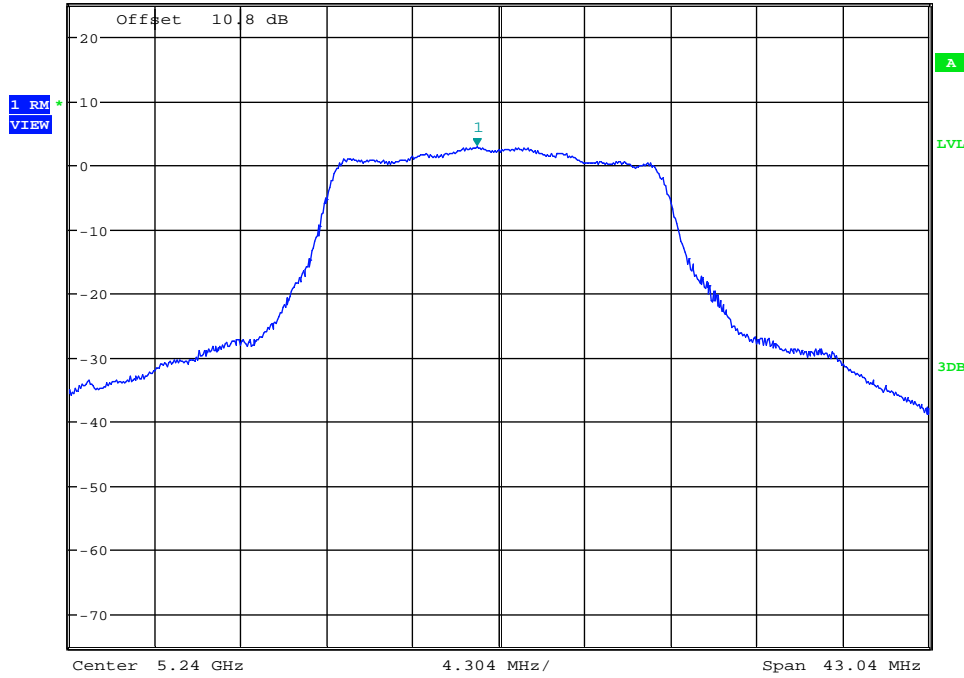

Date: 2.JAN.2018 15:10:47

Maximum Power Spectral Density\_TNVN\_11A\_5260\_Ant1



Ref 25 dBm      \* Att 20 dB      \* RBW 1 MHz      Marker 1 [T1 ]      3.15 dBm  
\* VBW 3 MHz      5.258910080 GHz  
SWT 20 ms

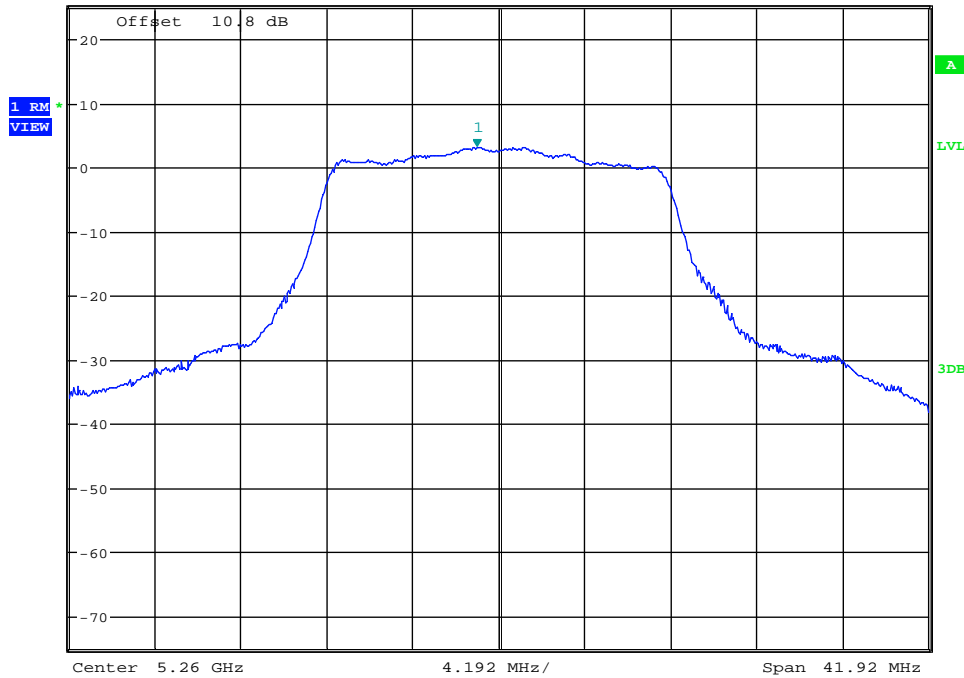

Date: 27.DEC.2017 20:43:15

Maximum Power Spectral Density\_TNVN\_11A\_5260\_Ant2



Ref 25 dBm      \* Att 20 dB      \* RBW 1 MHz      Marker 1 [T1 ]      3.56 dBm  
\* VBW 3 MHz      5.259035840 GHz  
SWT 20 ms

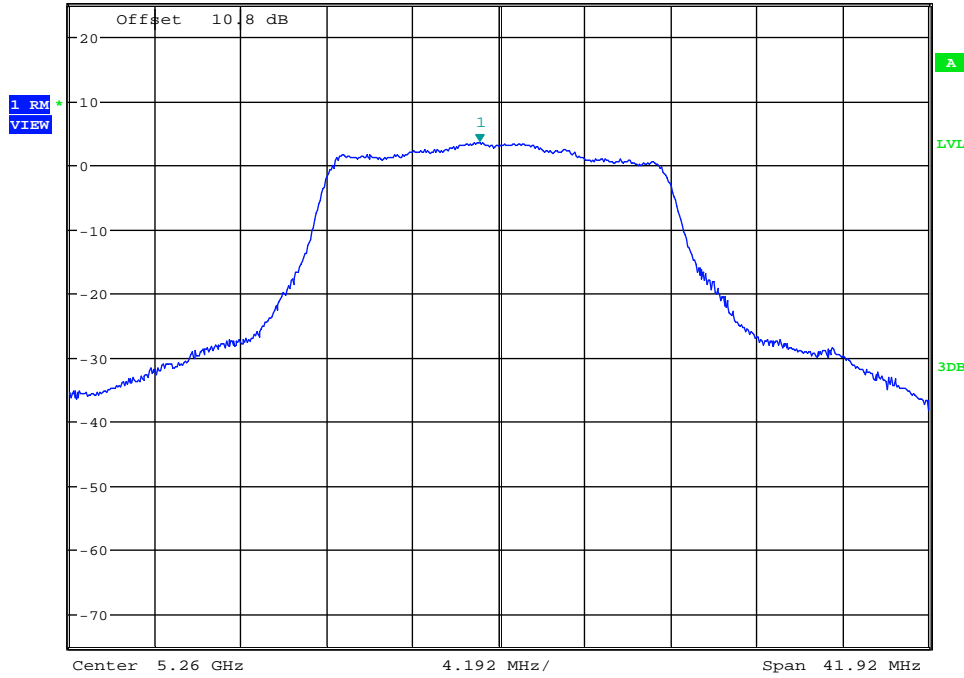

Date: 2.JAN.2018 15:17:19

Maximum Power Spectral Density\_TNVN\_11A\_5280\_Ant1



Ref 25 dBm      \* Att 20 dB      \* RBW 1 MHz      Marker 1 [T1 ]      3.15 dBm  
\* VBW 3 MHz      5.281162080 GHz  
SWT 20 ms

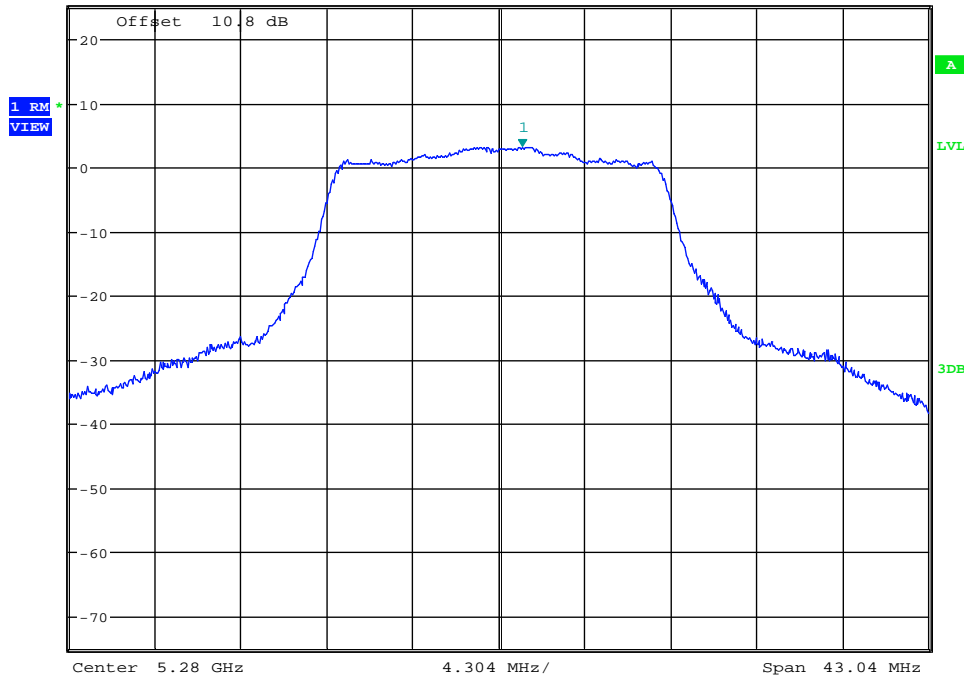

Date: 27.DEC.2017 20:48:32

Maximum Power Spectral Density\_TNVN\_11A\_5280\_Ant2



Ref 25 dBm      \* Att 20 dB      \* RBW 1 MHz      Marker 1 [T1 ]      3.82 dBm  
\* VBW 3 MHz      SWT 20 ms      5.279043200 GHz

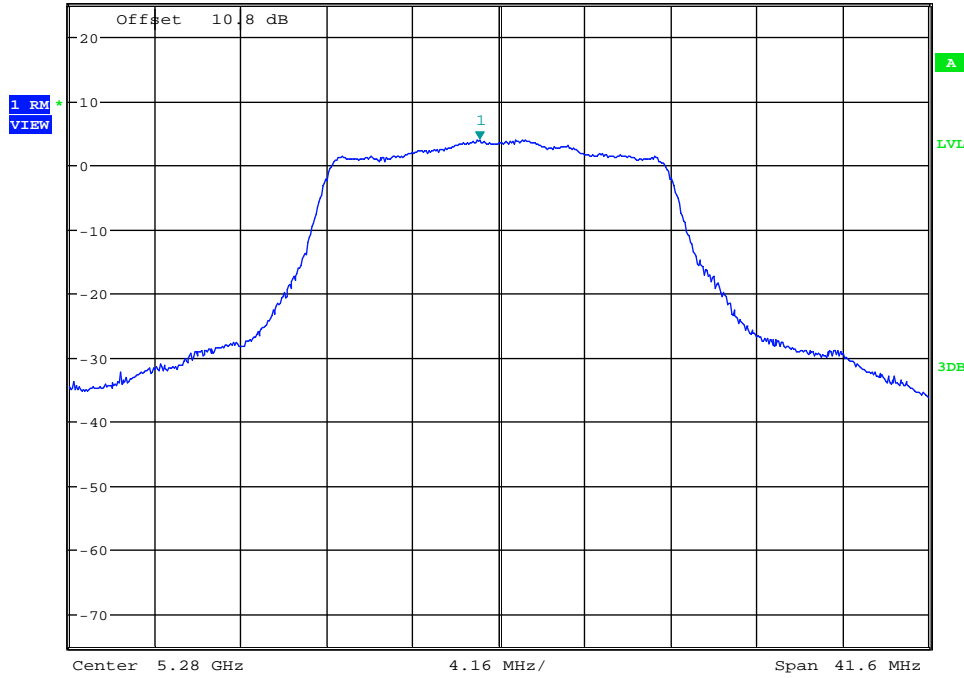

Date: 2.JAN.2018 15:23:11

Maximum Power Spectral Density\_TNVN\_11A\_5320\_Ant1



Ref 25 dBm      \* Att 20 dB      \* RBW 1 MHz      Marker 1 [T1 ]      3.96 dBm  
\* VBW 3 MHz      SWT 20 ms      5.319164800 GHz

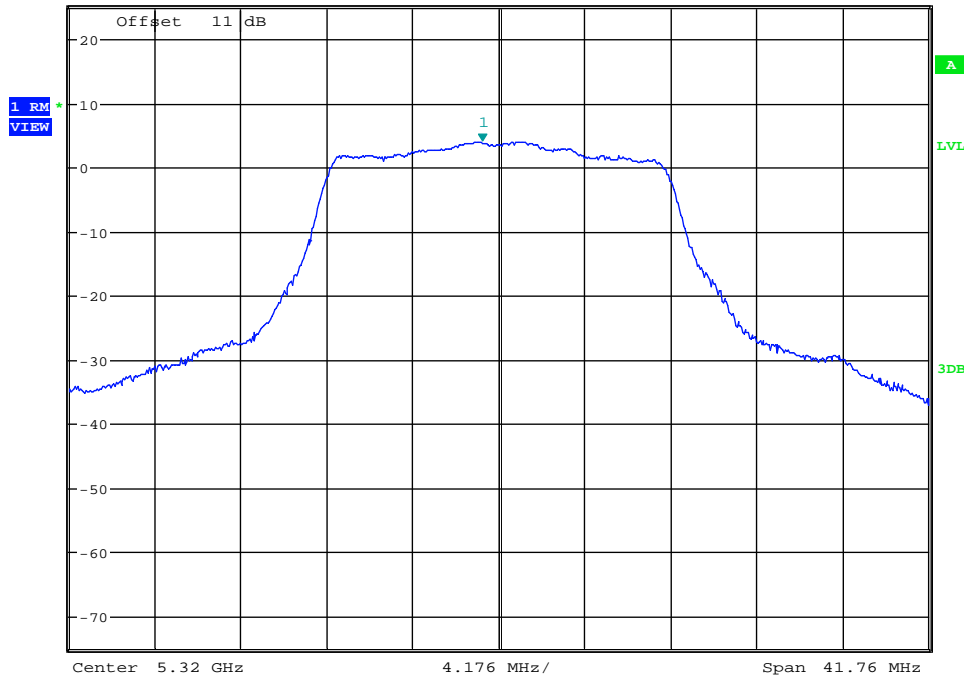

Date: 27.DEC.2017 20:53:09

Maximum Power Spectral Density\_TNVN\_11A\_5320\_Ant2



Ref 25 dBm      \* Att 20 dB      \* RBW 1 MHz      Marker 1 [T1 ]      4.24 dBm  
\* VBW 3 MHz      5.318995840 GHz  
SWT 20 ms

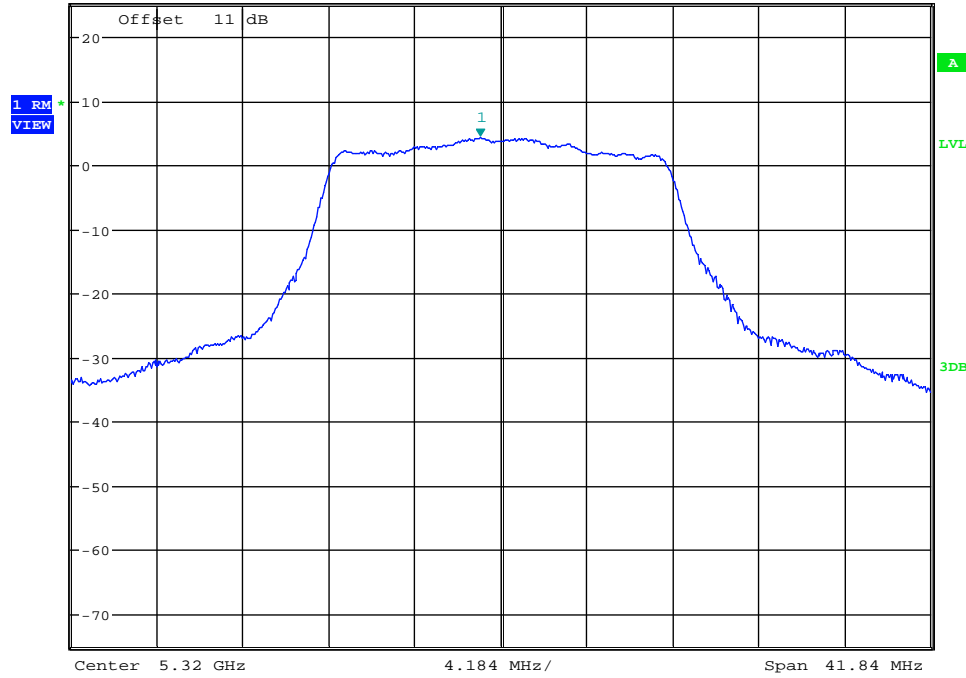

Date: 2.JAN.2018 15:28:07

Maximum Power Spectral Density\_TNVN\_11A\_5500\_Ant1



Ref 25 dBm      \* Att 20 dB      \* RBW 1 MHz      Marker 1 [T1 ]      3.84 dBm  
\* VBW 3 MHz      5.499037680 GHz  
SWT 20 ms

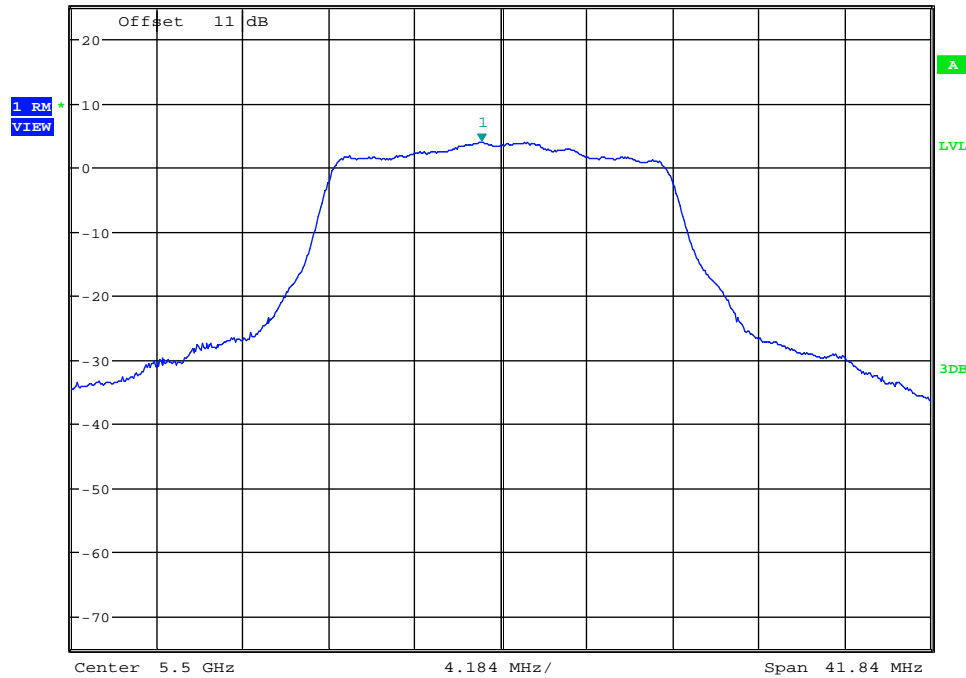

Date: 27.DEC.2017 20:58:49

Maximum Power Spectral Density\_TNVN\_11A\_5500\_Ant2



Ref 25 dBm      \* Att 20 dB      \* RBW 1 MHz      Marker 1 [T1 ]      3.44 dBm  
\* VBW 3 MHz      5.501155840 GHz  
SWT 20 ms

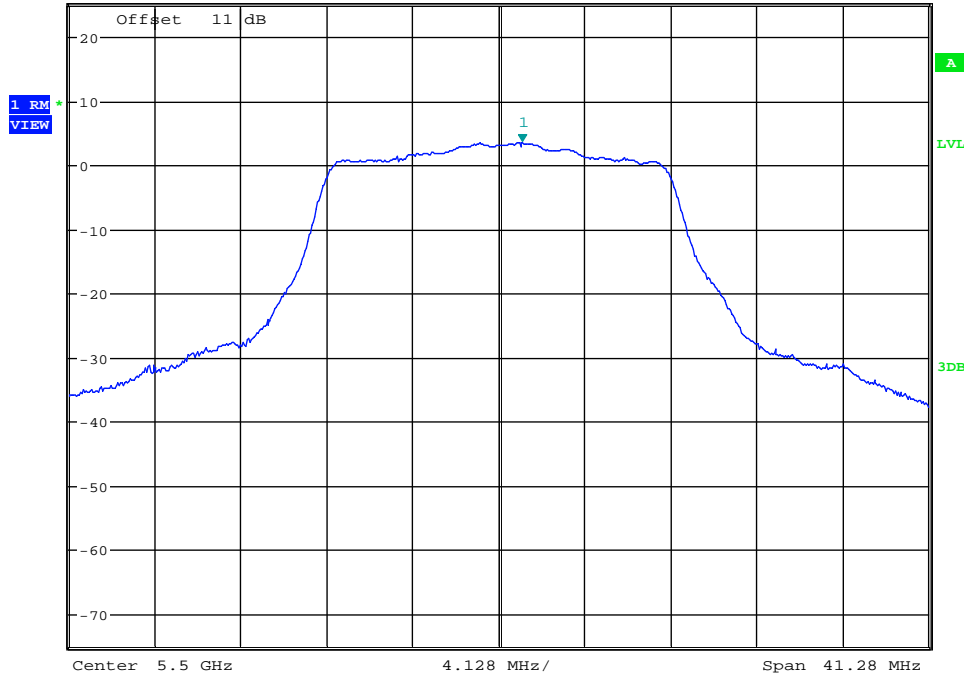

Date: 2.JAN.2018 15:53:45

Maximum Power Spectral Density\_TNVN\_11A\_5580\_Ant1



Ref 25 dBm      \* Att 20 dB      \* RBW 1 MHz      Marker 1 [T1 ]      2.71 dBm  
\* VBW 3 MHz      5.578992000 GHz  
SWT 20 ms

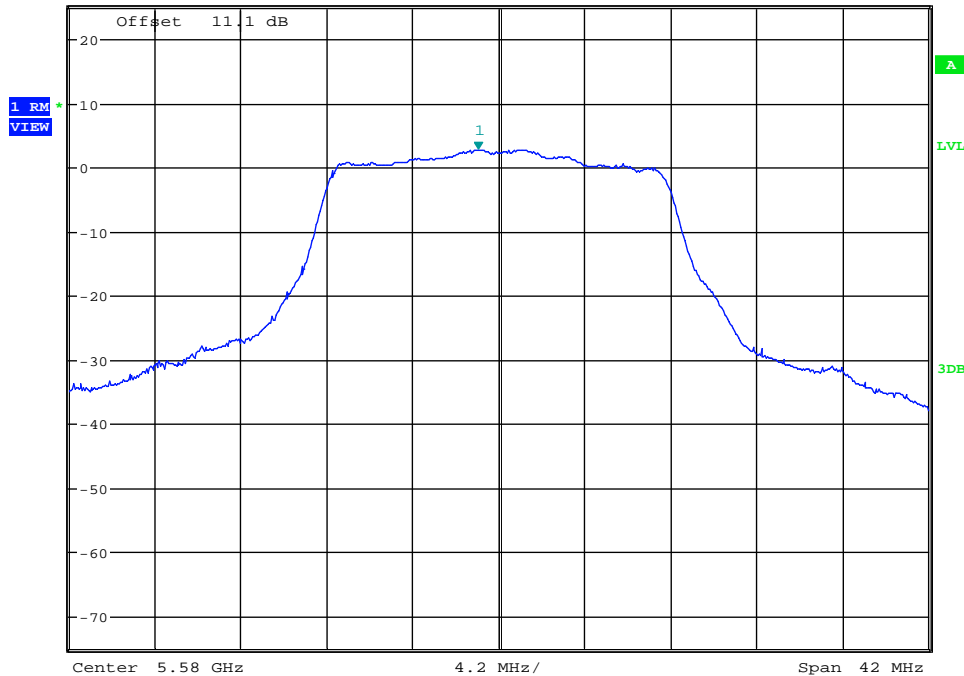

Date: 27.DEC.2017 21:06:11

Maximum Power Spectral Density\_TNVN\_11A\_5580\_Ant2



Ref 25 dBm      \* Att 20 dB      \* RBW 1 MHz      Marker 1 [T1 ]      2.64 dBm  
\* VBW 3 MHz      5.578995840 GHz  
SWT 20 ms

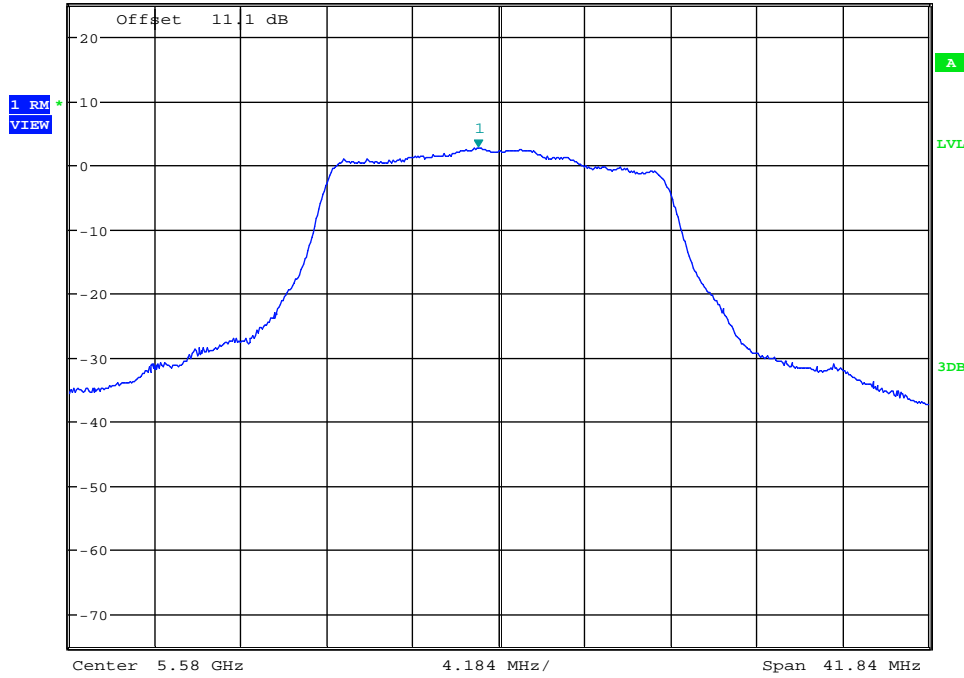

Date: 2.JAN.2018 15:58:57

Maximum Power Spectral Density\_TNVN\_11A\_5700\_Ant1



Ref 25 dBm      \* Att 20 dB      \* RBW 1 MHz      Marker 1 [T1 ]      2.84 dBm  
\* VBW 3 MHz      5.701302000 GHz  
SWT 20 ms

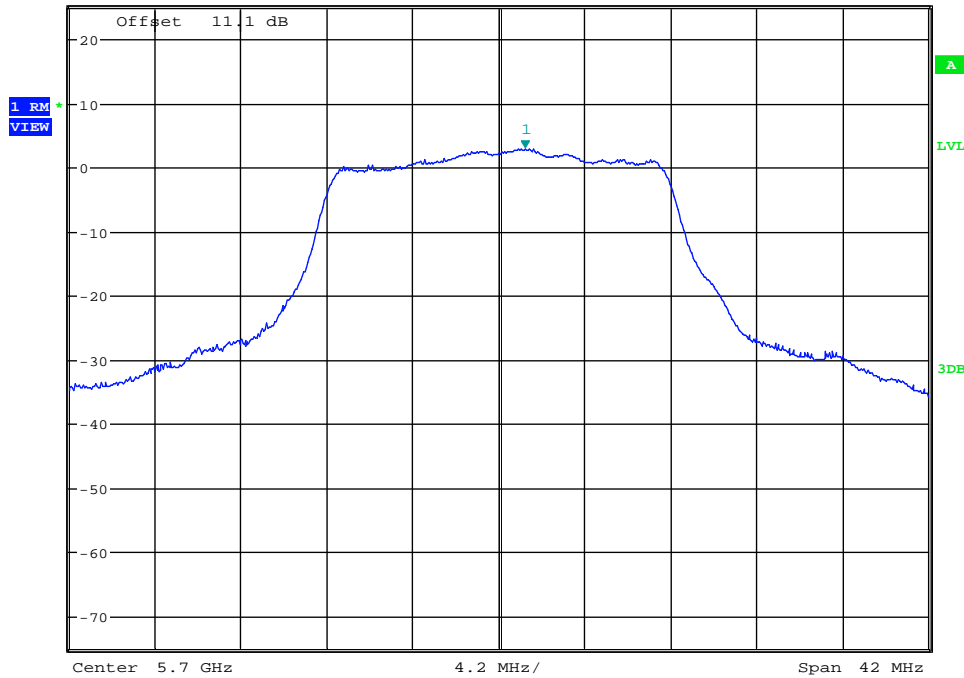

Date: 27.DEC.2017 21:10:58

Maximum Power Spectral Density\_TNVN\_11A\_5700\_Ant2

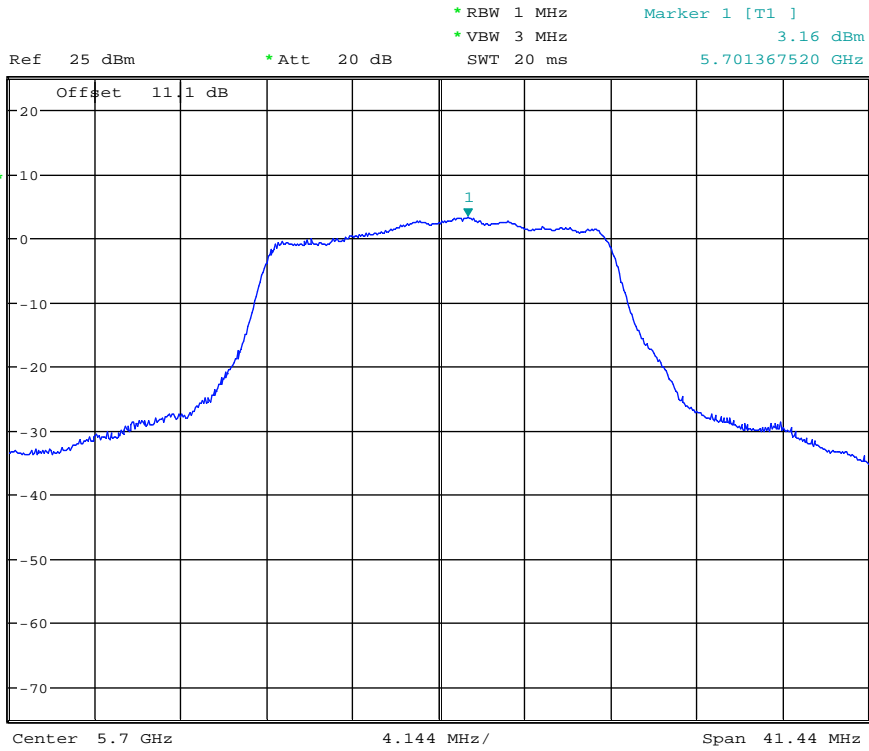

Date: 2.JAN.2018 16:05:59

Maximum Power Spectral Density\_TNVN\_11A\_5745\_Ant1

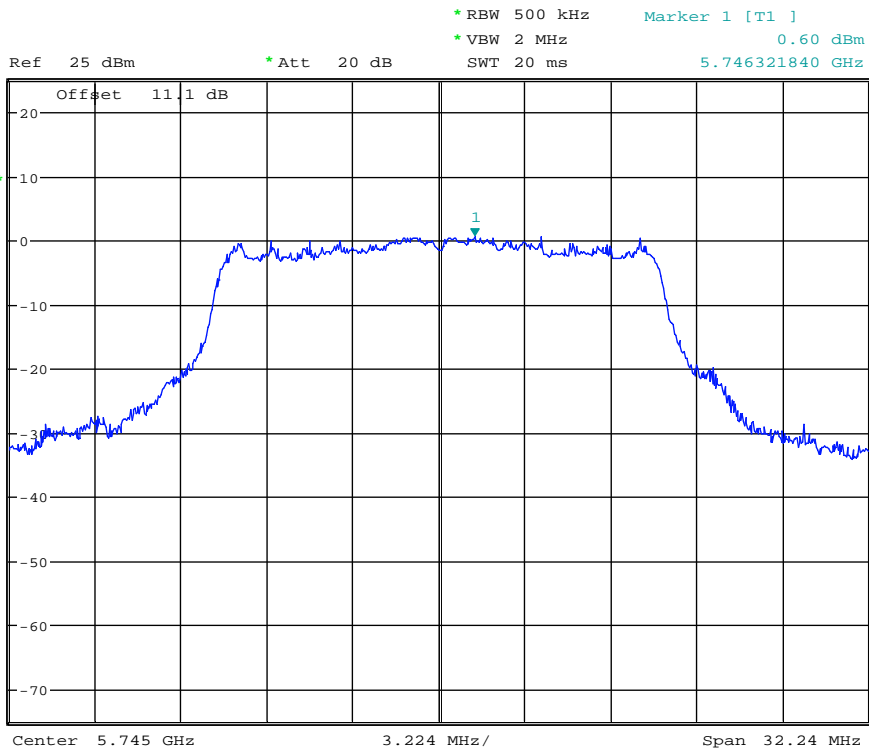

Date: 27.DEC.2017 21:15:15

Maximum Power Spectral Density\_TNVN\_11A\_5745\_Ant2



Ref 25 dBm \* Att 20 dB \* RBW 500 kHz Marker 1 [T1 ]  
\* VBW 2 MHz 1.27 dBm  
SWT 20 ms 5.750036560 GHz

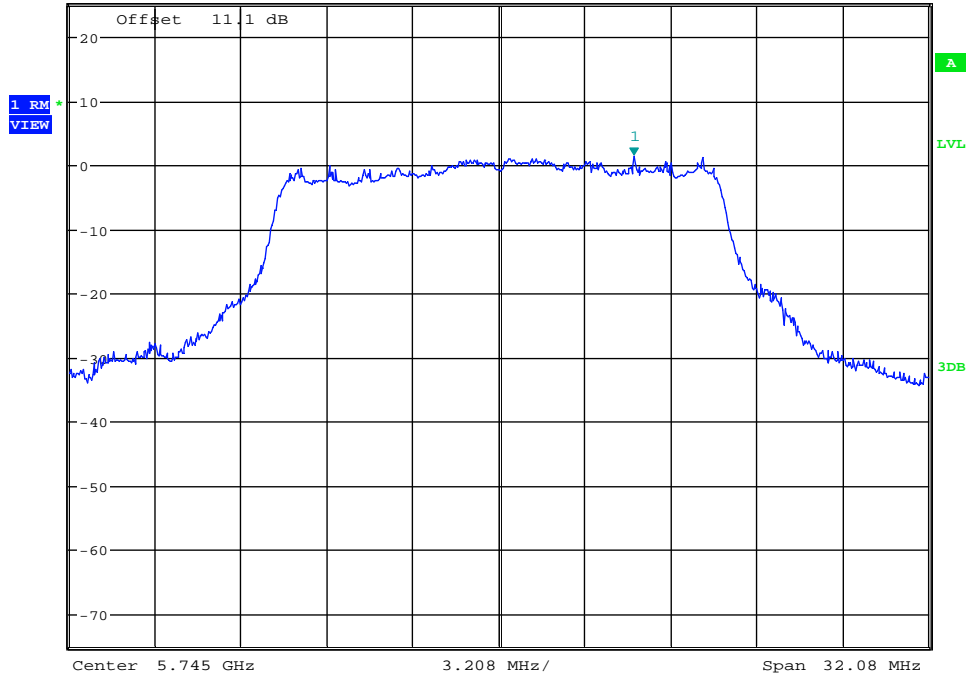

Date: 2.JAN.2018 16:11:40

Maximum Power Spectral Density\_TNVN\_11A\_5785\_Ant1



Ref 25 dBm \* Att 20 dB \* RBW 500 kHz Marker 1 [T1 ]  
\* VBW 2 MHz 2.01 dBm  
SWT 20 ms 5.786243360 GHz

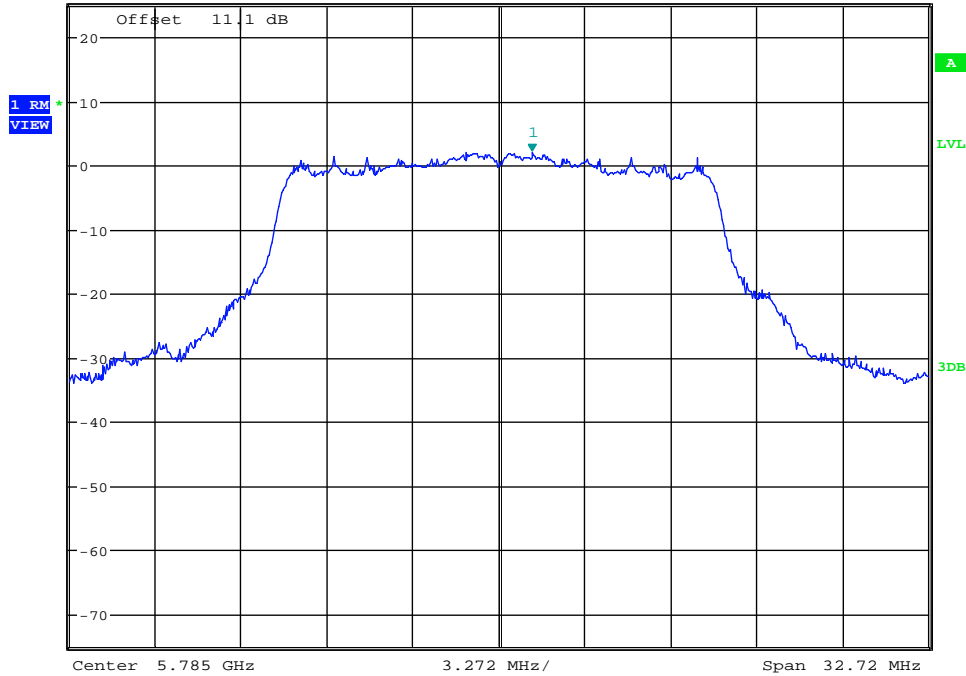

Date: 27.DEC.2017 21:22:01

Maximum Power Spectral Density\_TNVN\_11A\_5785\_Ant2



Ref 25 dBm      \* Att 20 dB      \* RBW 500 kHz      Marker 1 [T1 ]      1.96 dBm  
\* VBW 2 MHz      5.784276640 GHz  
SWT 20 ms

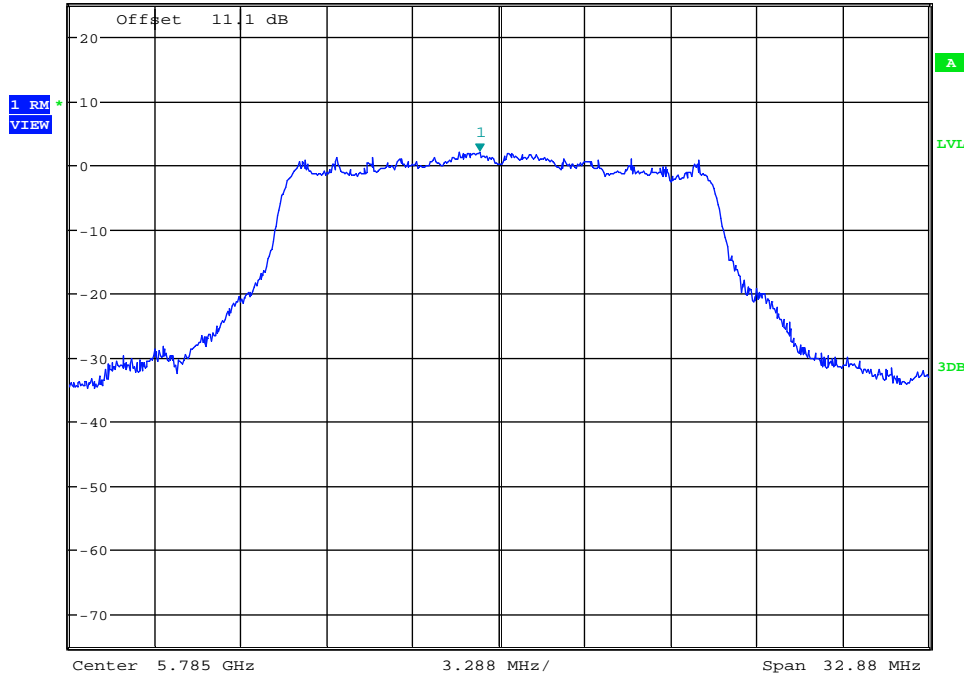

Date: 2.JAN.2018 16:15:47

Maximum Power Spectral Density\_TNVN\_11A\_5825\_Ant1



Ref 25 dBm      \* Att 20 dB      \* RBW 500 kHz      Marker 1 [T1 ]      1.88 dBm  
\* VBW 2 MHz      5.825426400 GHz  
SWT 20 ms

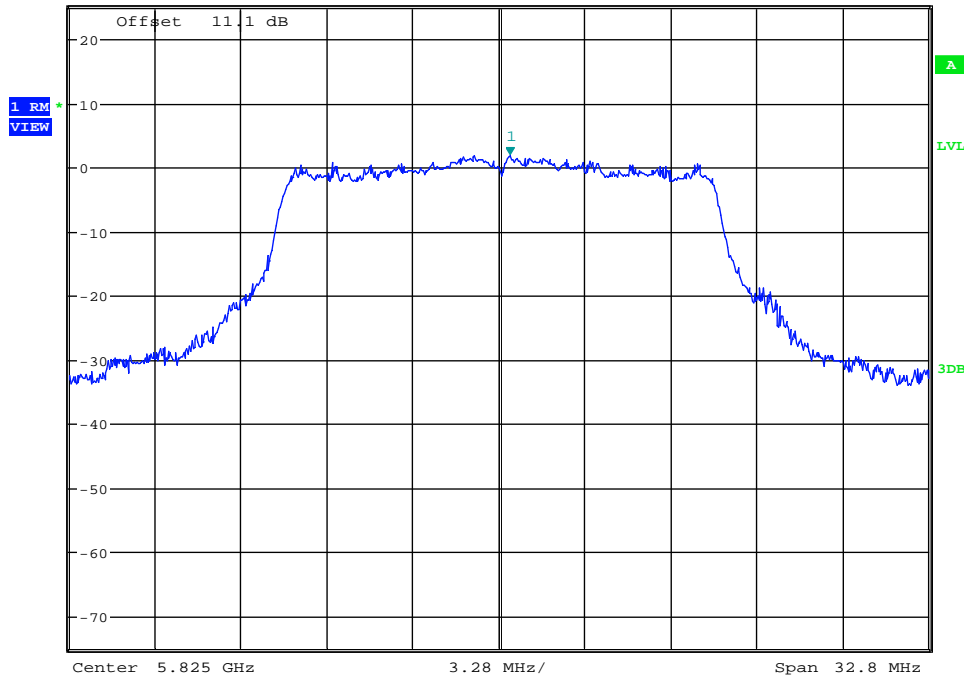

Date: 27.DEC.2017 21:25:34

Maximum Power Spectral Density\_TNVN\_11A\_5825\_Ant2



Ref 25 dBm \* Att 20 dB \* RBW 500 kHz Marker 1 [T1 ] 1.34 dBm  
\* VBW 2 MHz 5.823849200 GHz  
SWT 20 ms

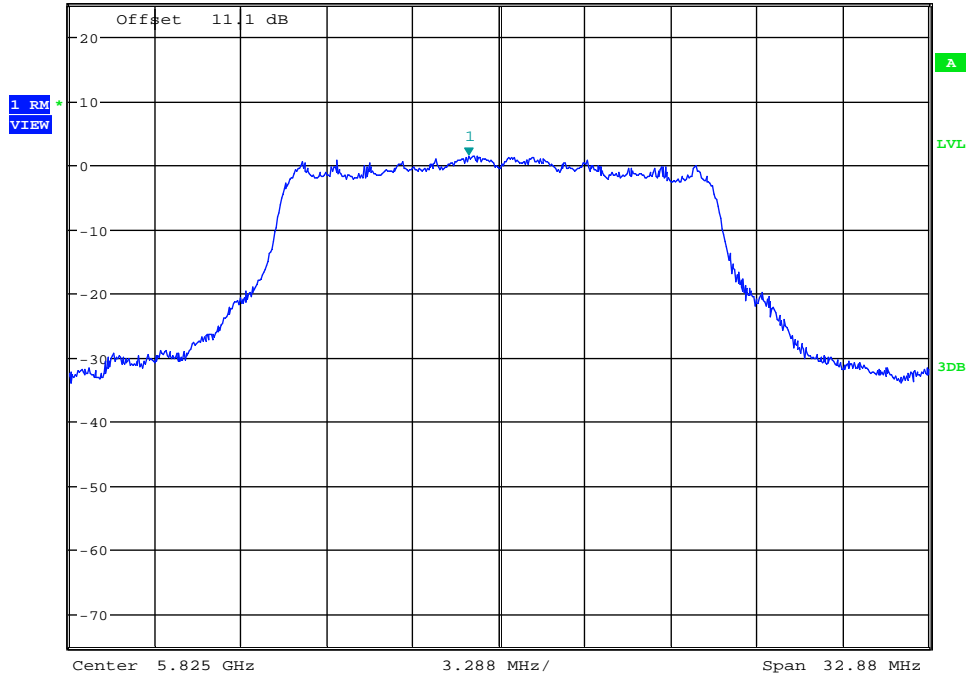

Date: 2.JAN.2018 16:19:34

Maximum Power Spectral Density\_TNVN\_11N20SISO\_5180\_Ant1



Ref 25 dBm \* Att 20 dB \* RBW 1 MHz Marker 1 [T1 ] 3.31 dBm  
\* VBW 3 MHz 5.178245200 GHz  
SWT 20 ms

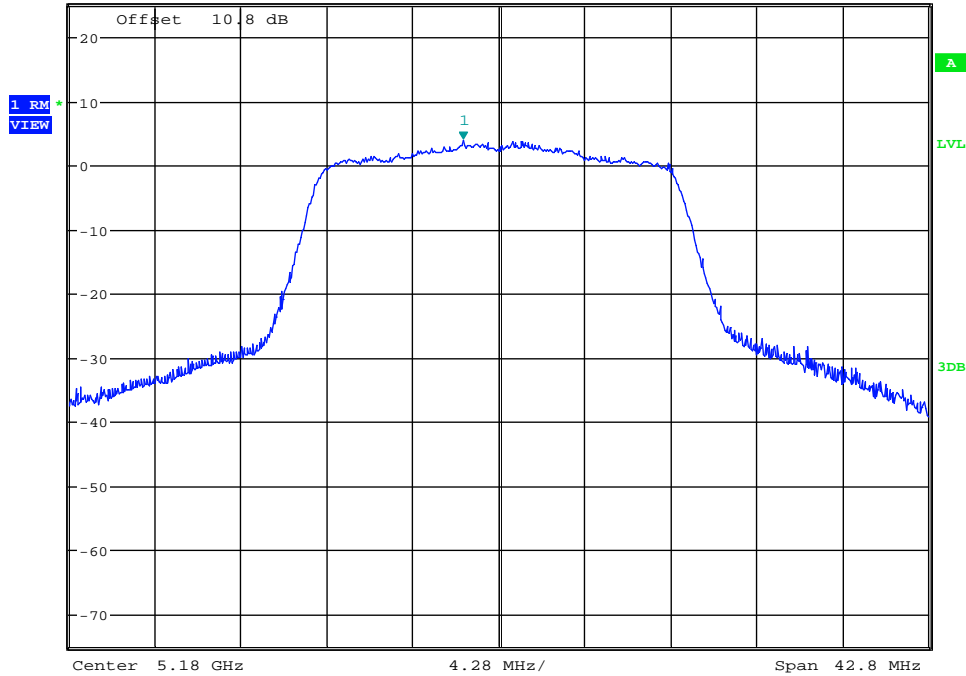

Date: 28.DEC.2017 08:36:49

Maximum Power Spectral Density\_TNVN\_11N20SISO\_5180\_Ant2



Ref 25 dBm \* Att 20 dB \* RBW 1 MHz Marker 1 [T1 ] 2.49 dBm  
\* VBW 3 MHz 5.178978560 GHz  
SWT 20 ms

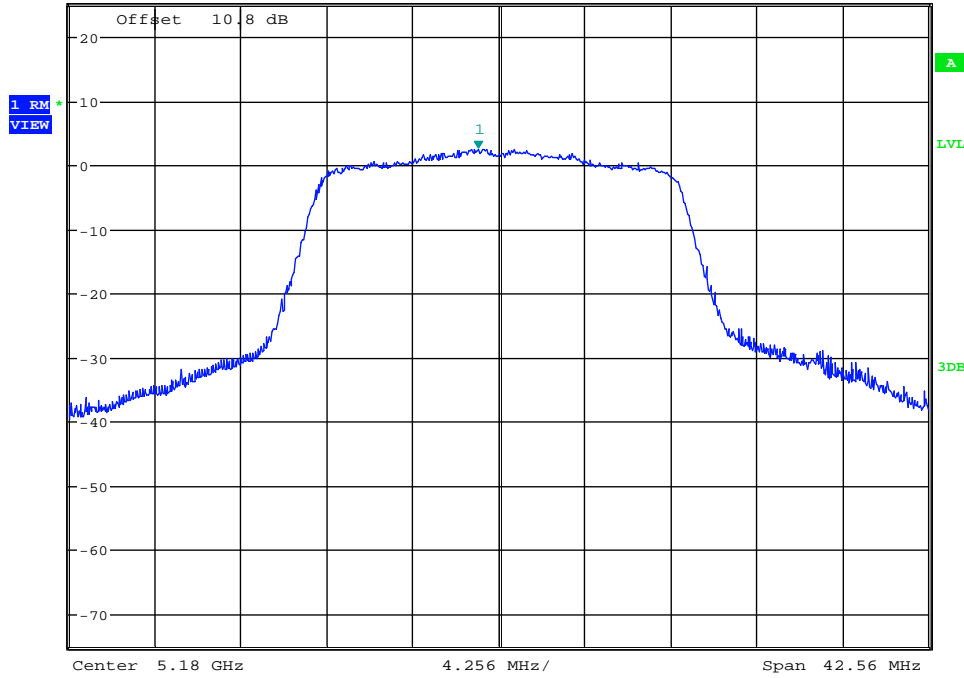

Date: 2.JAN.2018 16:24:41

Maximum Power Spectral Density\_TNVN\_11N20SISO\_5200\_Ant1



Ref 25 dBm \* Att 20 dB \* RBW 1 MHz Marker 1 [T1 ] 2.76 dBm  
\* VBW 3 MHz 5.198333920 GHz  
SWT 20 ms

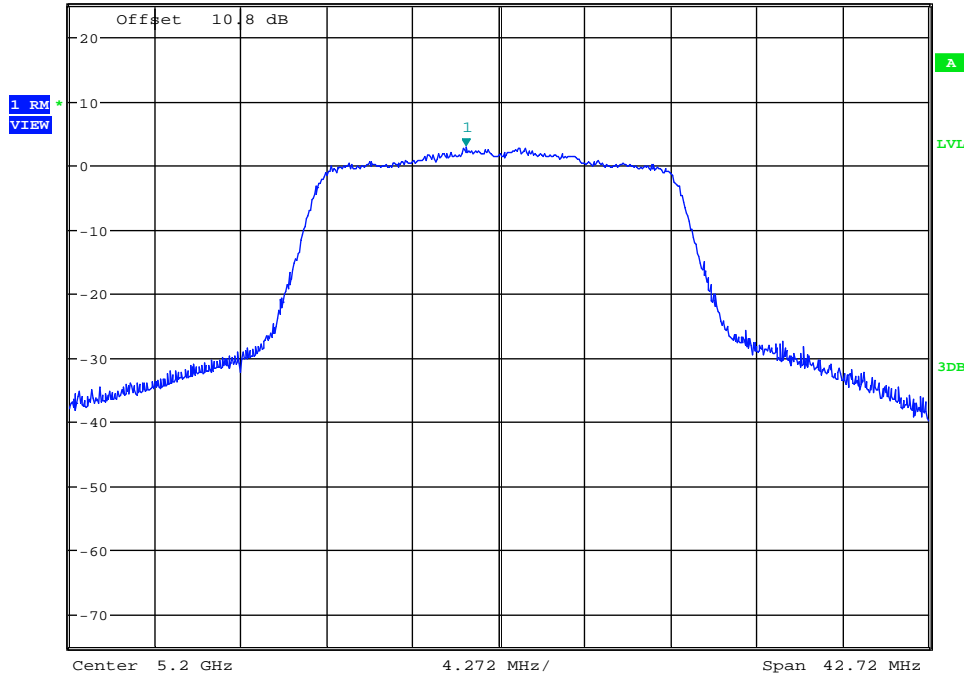

Date: 28.DEC.2017 08:42:00

Maximum Power Spectral Density\_TNVN\_11N20SISO\_5200\_Ant2



Ref 25 dBm      \* Att 20 dB      \* RBW 1 MHz      Marker 1 [T1 ]      3.13 dBm  
\* VBW 3 MHz      5.200980720 GHz  
SWT 20 ms

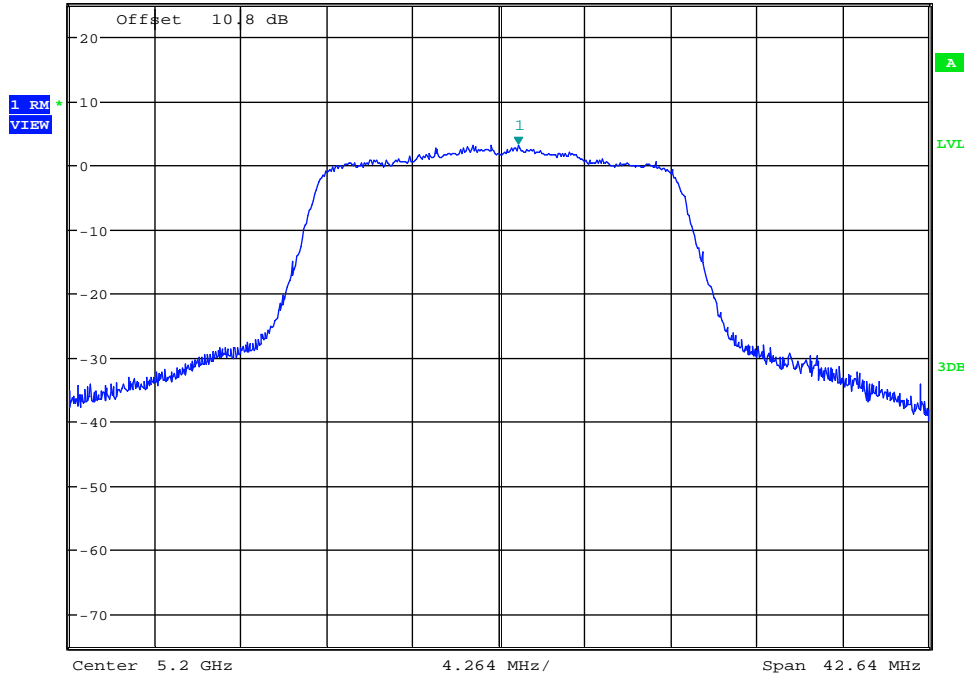

Date: 2.JAN.2018 16:30:34

Maximum Power Spectral Density\_TNVN\_11N20SISO\_5240\_Ant1



Ref 25 dBm      \* Att 20 dB      \* RBW 1 MHz      Marker 1 [T1 ]      3.28 dBm  
\* VBW 3 MHz      5.241142640 GHz  
SWT 20 ms

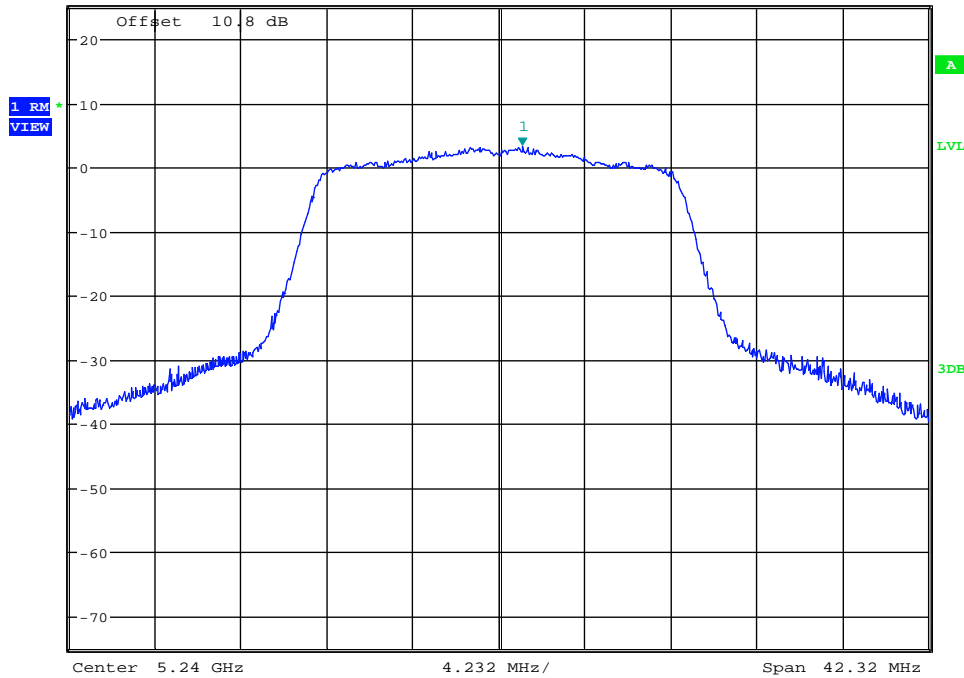

Date: 28.DEC.2017 08:46:41

Maximum Power Spectral Density\_TNVN\_11N20SISO\_5240\_Ant2



Ref 25 dBm \* Att 20 dB \* RBW 1 MHz Marker 1 [T1 ] 1.76 dBm  
\* VBW 3 MHz 5.238673200 GHz  
SWT 20 ms

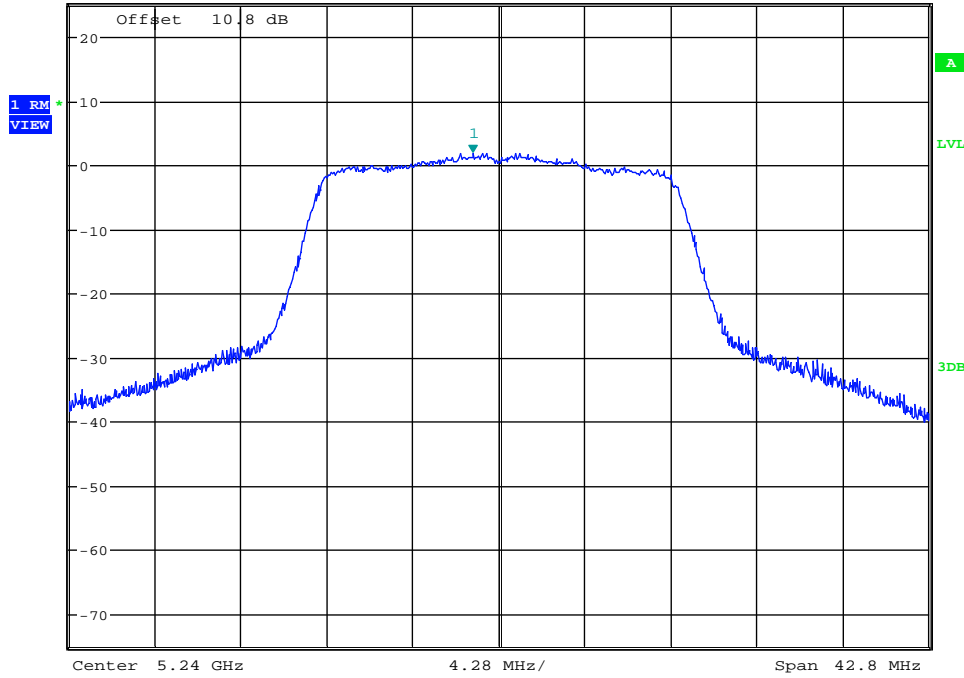

Date: 2.JAN.2018 16:35:33

Maximum Power Spectral Density\_TNVN\_11N20SISO\_5260\_Ant1



Ref 25 dBm \* Att 20 dB \* RBW 1 MHz Marker 1 [T1 ] -1.44 dBm  
\* VBW 3 MHz 5.261017600 GHz  
SWT 20 ms

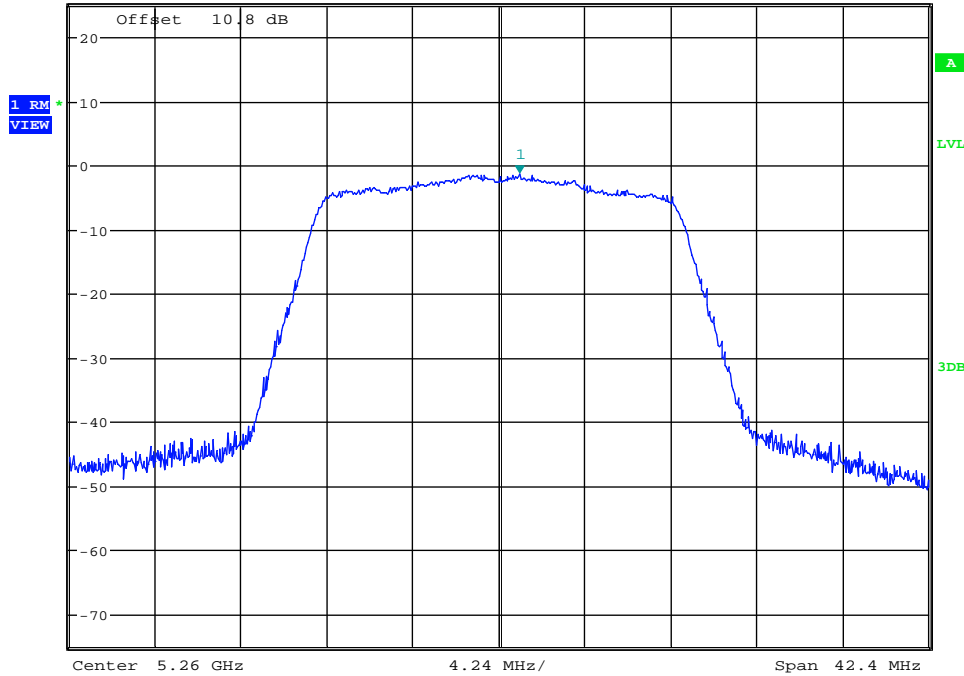

Date: 28.DEC.2017 20:38:42

Maximum Power Spectral Density\_TNVN\_11N20SISO\_5260\_Ant2



Ref 25 dBm \* Att 20 dB \* RBW 1 MHz \* VBW 3 MHz \* SWT 20 ms Marker 1 [T1 ] -0.93 dBm 5.260969680 GHz

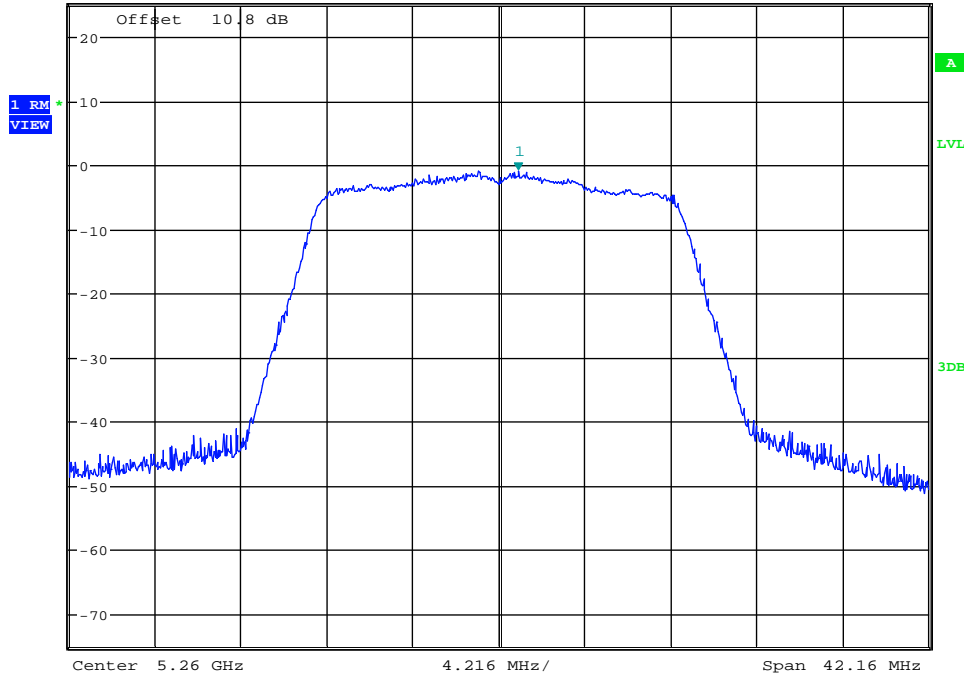

Date: 2.JAN.2018 16:42:02

Maximum Power Spectral Density\_TNVN\_11N20SISO\_5280\_Ant1



Ref 25 dBm \* Att 20 dB \* RBW 1 MHz \* VBW 3 MHz \* SWT 20 ms Marker 1 [T1 ] -0.85 dBm 5.281324320 GHz

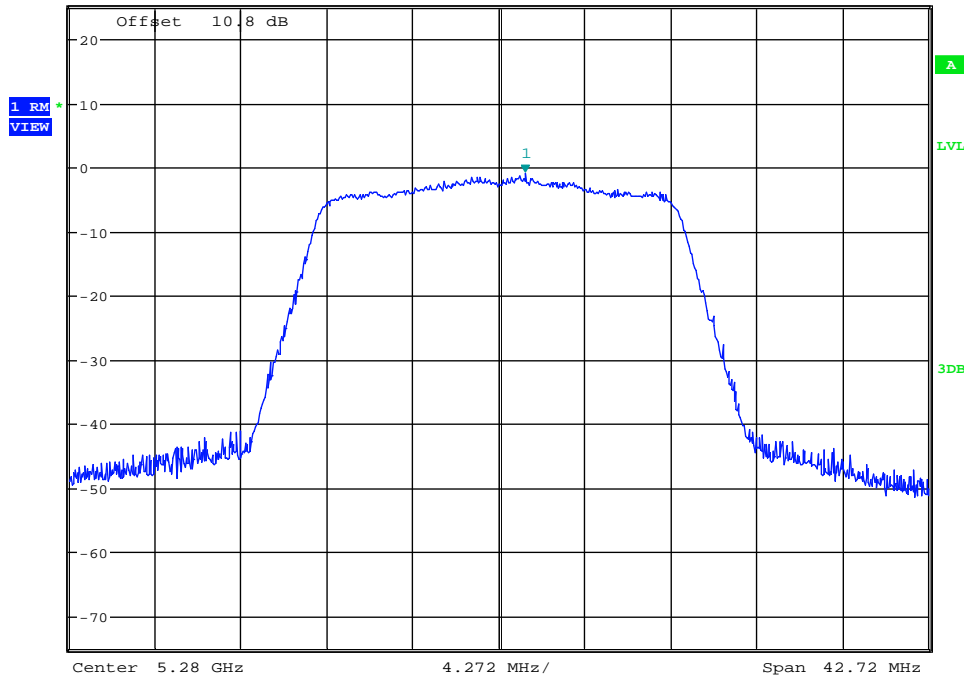

Date: 28.DEC.2017 20:44:03

Maximum Power Spectral Density\_TNVN\_11N20SISO\_5280\_Ant2



Ref 25 dBm \* Att 20 dB \* RBW 1 MHz \* VBW 3 MHz \* SWT 20 ms Marker 1 [T1 ] -0.19 dBm  
5.279239680 GHz

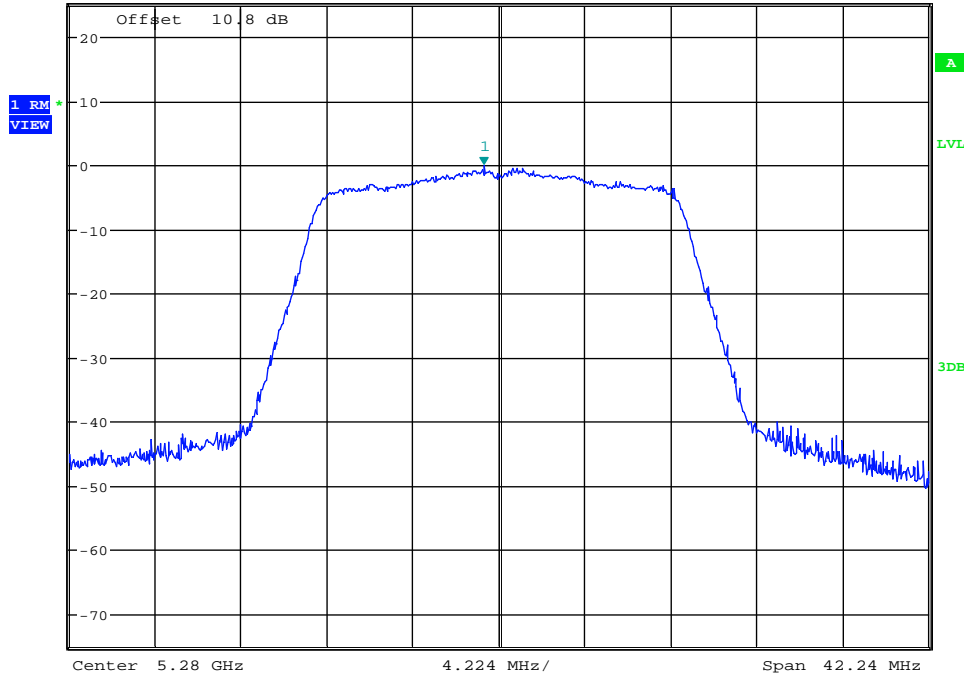

Date: 2.JAN.2018 16:47:14

Maximum Power Spectral Density\_TNVN\_11N20SISO\_5320\_Ant1



Ref 25 dBm \* Att 20 dB \* RBW 1 MHz \* VBW 3 MHz \* SWT 20 ms Marker 1 [T1 ] -0.30 dBm  
5.319487360 GHz

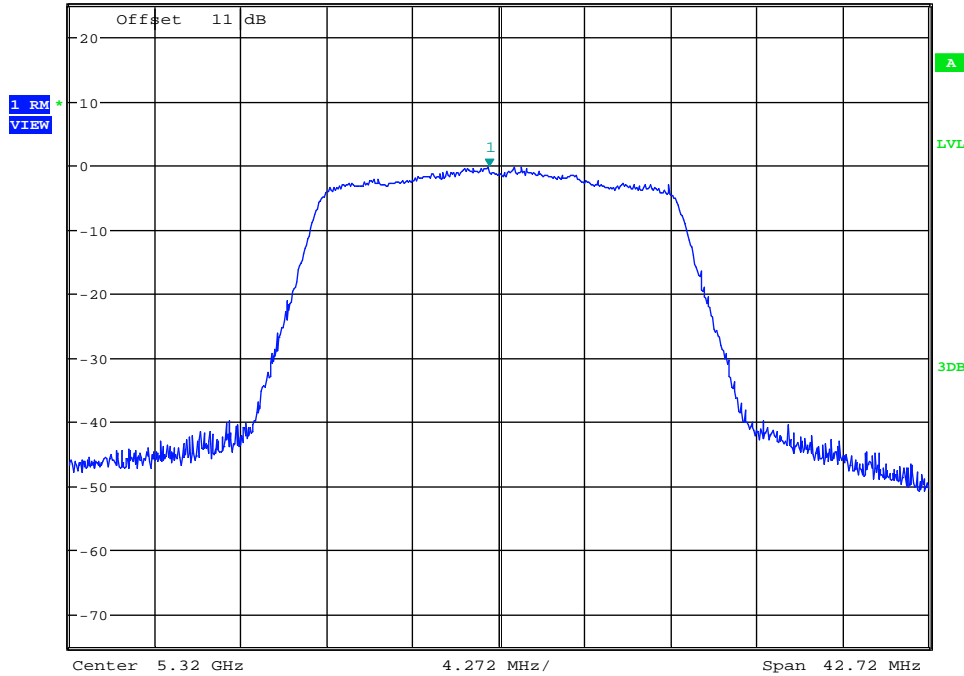

Date: 28.DEC.2017 20:50:53

Maximum Power Spectral Density\_TNVN\_11N20SISO\_5320\_Ant2



Ref 25 dBm \* Att 20 dB \* RBW 1 MHz Marker 1 [T1 ] -0.05 dBm  
\* VBW 3 MHz 5.320854400 GHz  
SWT 20 ms

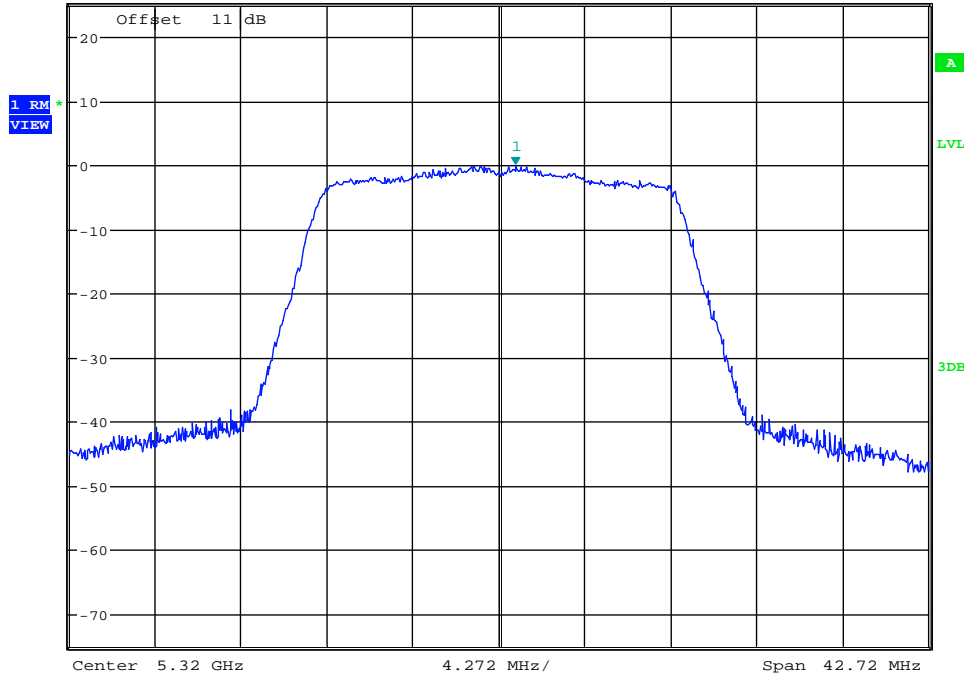

Date: 2.JAN.2018 16:51:55

### Maximum Power Spectral Density\_TNVN\_11N20SISO\_5500\_Ant1



Ref 25 dBm \* Att 20 dB \* RBW 1 MHz Marker 1 [T1 ] 2.75 dBm  
\* VBW 3 MHz 5.501102400 GHz  
SWT 20 ms

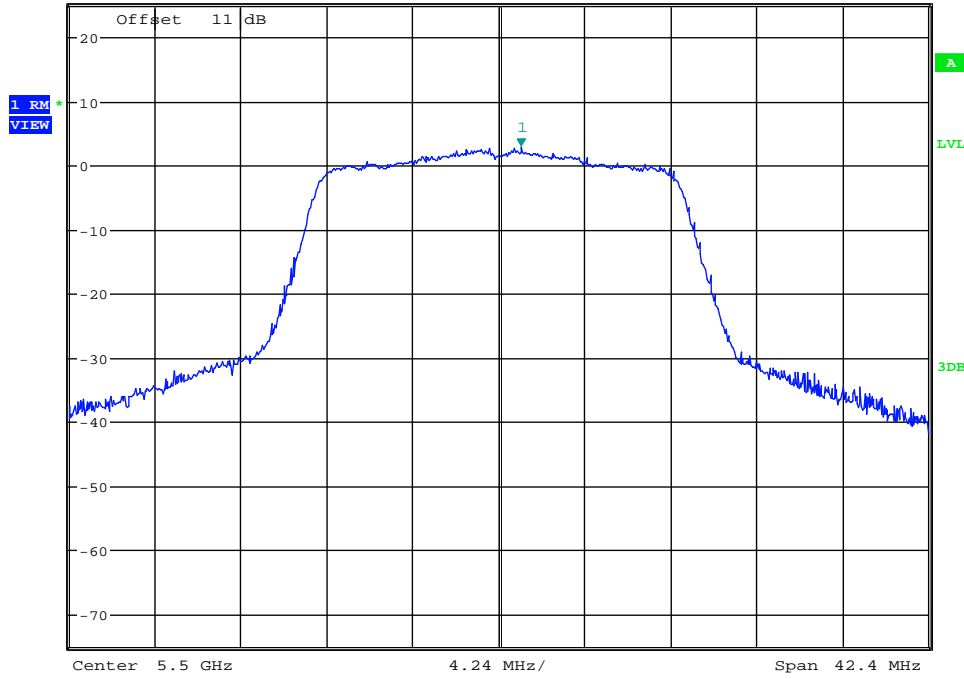

Date: 28.DEC.2017 20:56:10

### Maximum Power Spectral Density\_TNVN\_11N20SISO\_5500\_Ant2



Ref 25 dBm      \* Att 20 dB      \* RBW 1 MHz      Marker 1 [T1 ]      2.17 dBm  
\* VBW 3 MHz      5.499111280 GHz  
SWT 20 ms

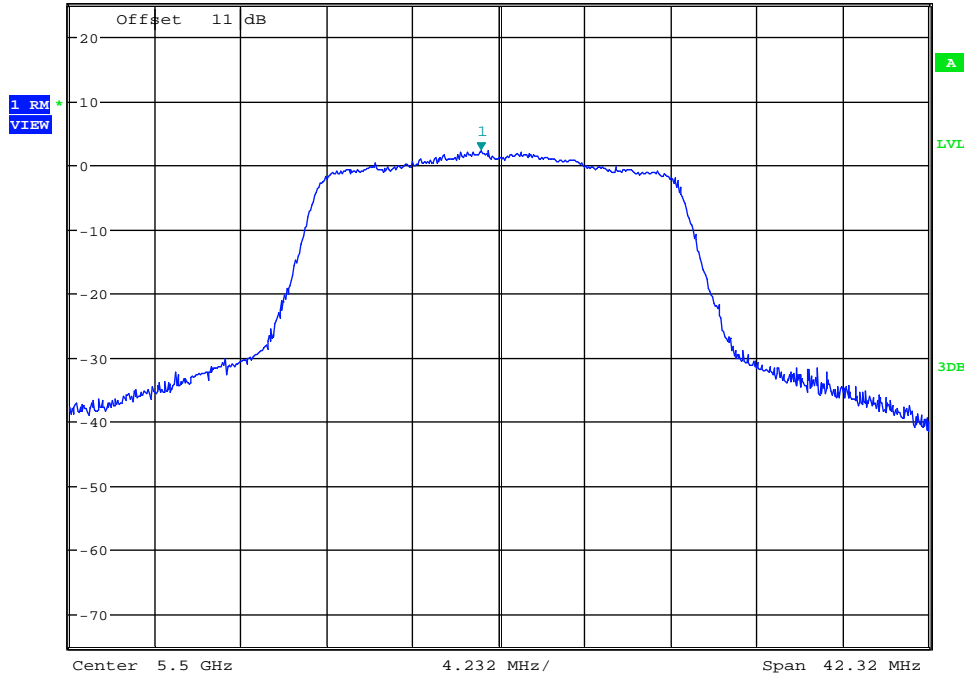

Date: 2.JAN.2018 16:57:17

Maximum Power Spectral Density\_TNVN\_11N20SISO\_5580\_Ant1



Ref 25 dBm      \* Att 20 dB      \* RBW 1 MHz      Marker 1 [T1 ]      1.76 dBm  
\* VBW 3 MHz      5.581142640 GHz  
SWT 20 ms

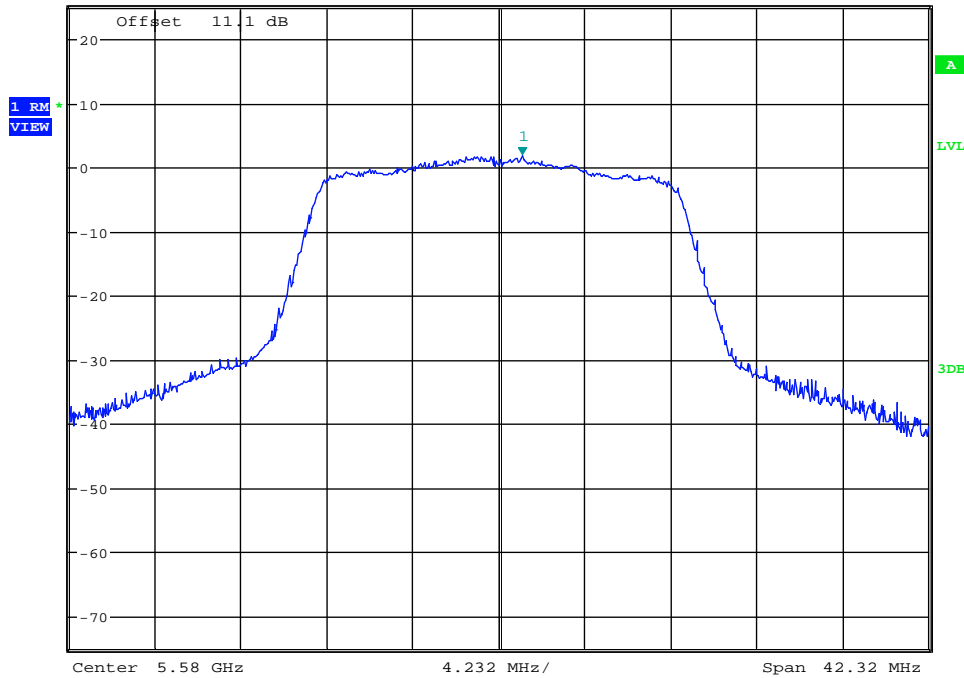

Date: 28.DEC.2017 21:02:44

Maximum Power Spectral Density\_TNVN\_11N20SISO\_5580\_Ant2

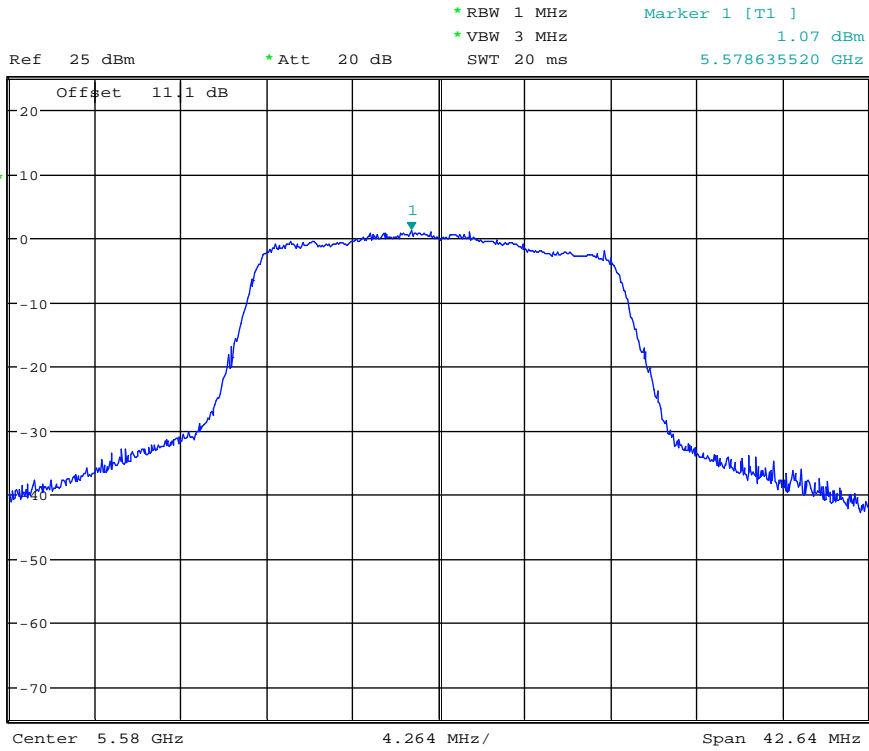

Date: 2.JAN.2018 17:02:47

Maximum Power Spectral Density\_TNVN\_11N20SISO\_5700\_Ant1

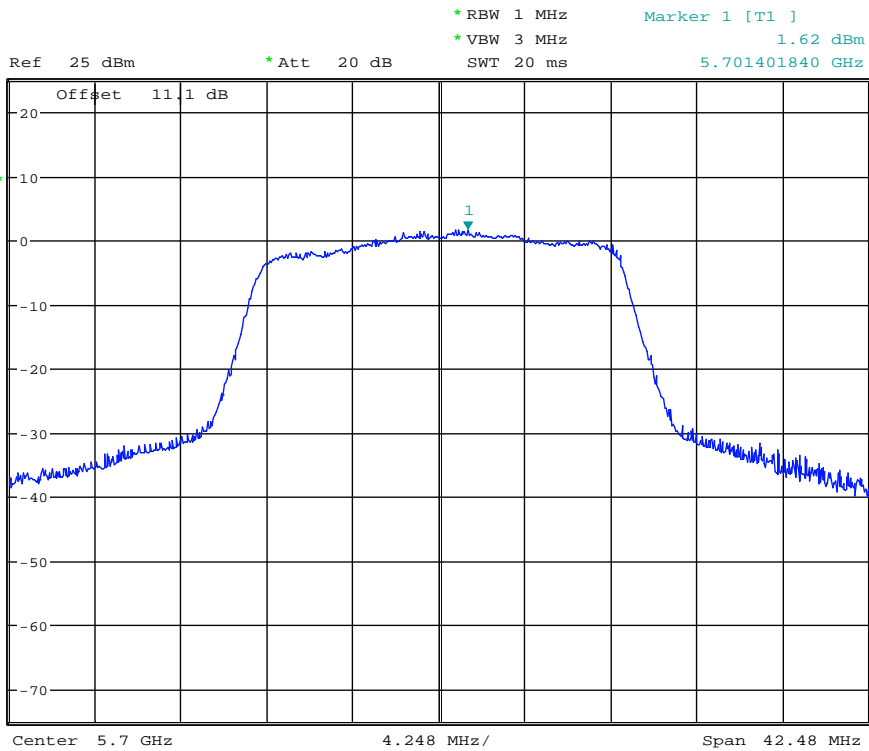

Date: 28.DEC.2017 21:11:08

Maximum Power Spectral Density\_TNVN\_11N20SISO\_5700\_Ant2



Ref 25 dBm \* Att 20 dB \* RBW 1 MHz Marker 1 [T1 ] 1.84 dBm  
\* VBW 3 MHz 5.701064000 GHz  
SWT 20 ms

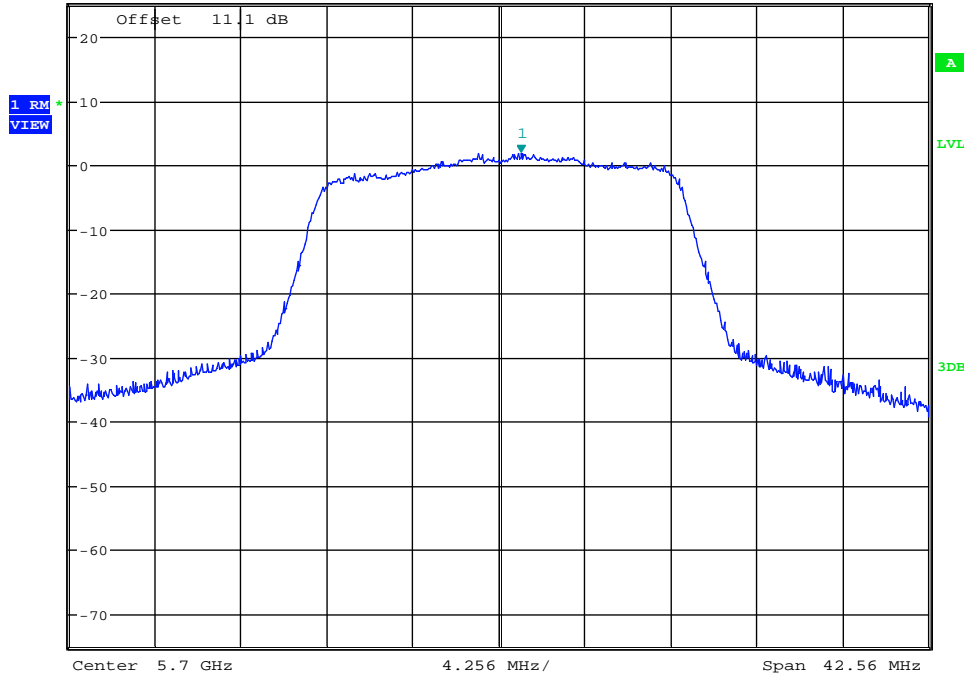

Date: 2.JAN.2018 17:07:33

Maximum Power Spectral Density\_TNVN\_11N20SISO\_5745\_Ant1



Ref 25 dBm \* Att 20 dB \* RBW 500 kHz Marker 1 [T1 ] -1.07 dBm  
\* VBW 2 MHz 5.744257440 GHz  
SWT 20 ms

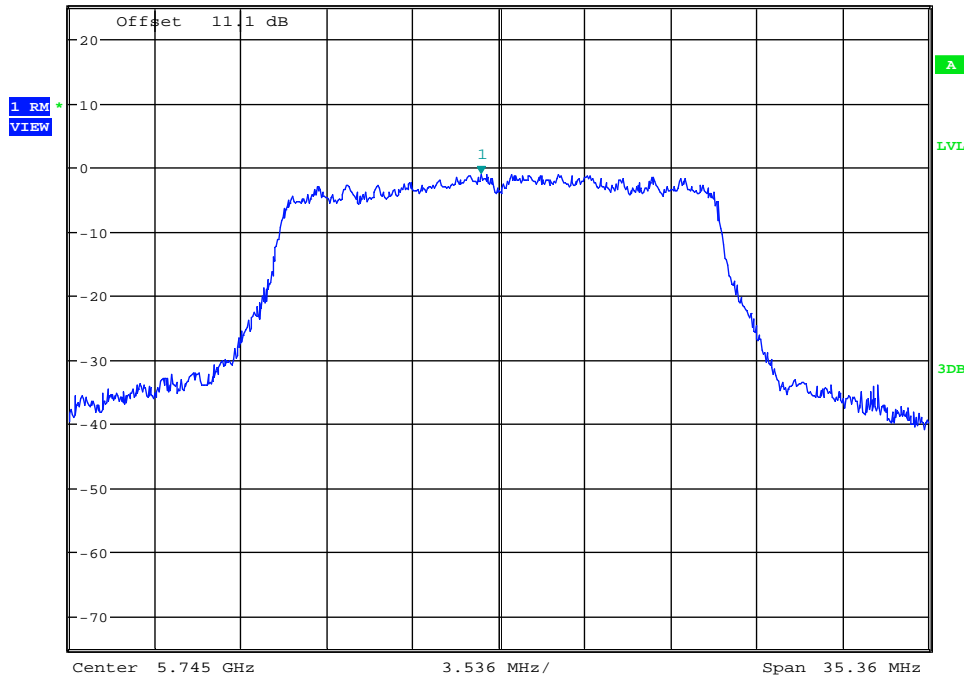

Date: 28.DEC.2017 21:16:06

Maximum Power Spectral Density\_TNVN\_11N20SISO\_5745\_Ant2



Ref 25 dBm      \* Att 20 dB      \* RBW 500 kHz      Marker 1 [T1 ]  
\* VBW 2 MHz      -0.48 dBm  
SWT 20 ms      5.743550240 GHz

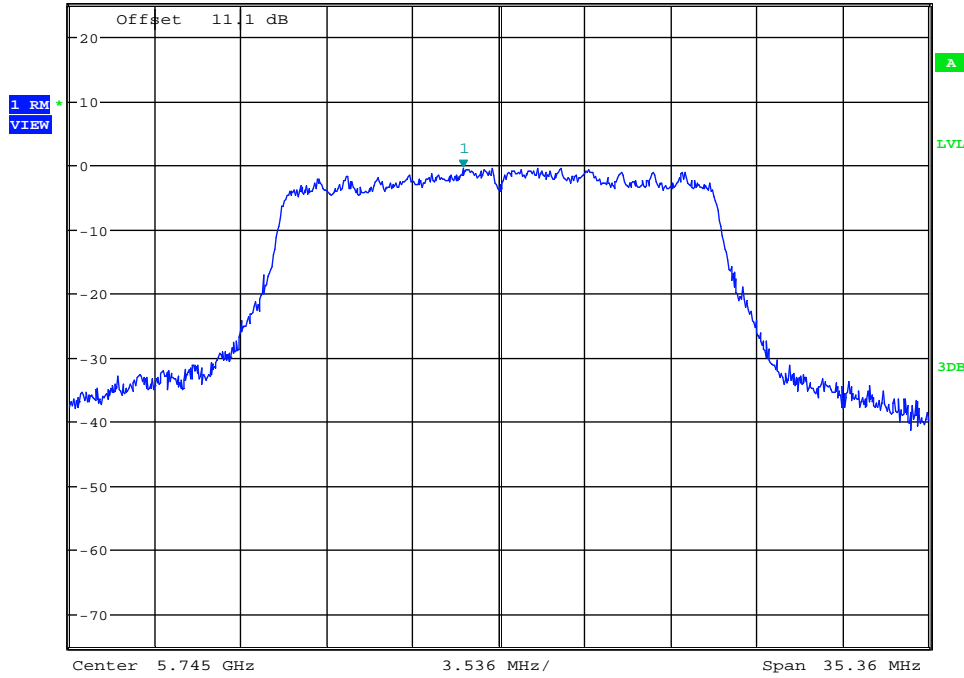

Date: 2.JAN.2018 17:34:18

Maximum Power Spectral Density\_TNVN\_11N20SISO\_5785\_Ant1



Ref 25 dBm      \* Att 20 dB      \* RBW 500 kHz      Marker 1 [T1 ]  
\* VBW 2 MHz      0.65 dBm  
SWT 20 ms      5.783546960 GHz

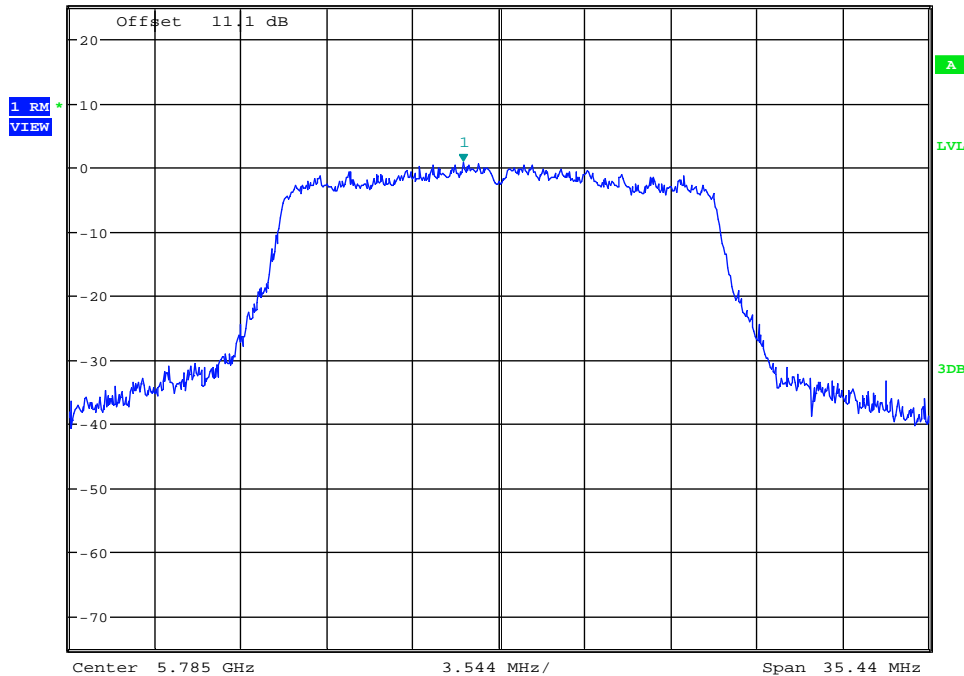

Date: 28.DEC.2017 21:21:15

Maximum Power Spectral Density\_TNVN\_11N20SISO\_5785\_Ant2



Ref 25 dBm \* Att 20 dB \* RBW 500 kHz Marker 1 [T1 ] 0.37 dBm  
\* VBW 2 MHz SWT 20 ms 5.785762080 GHz

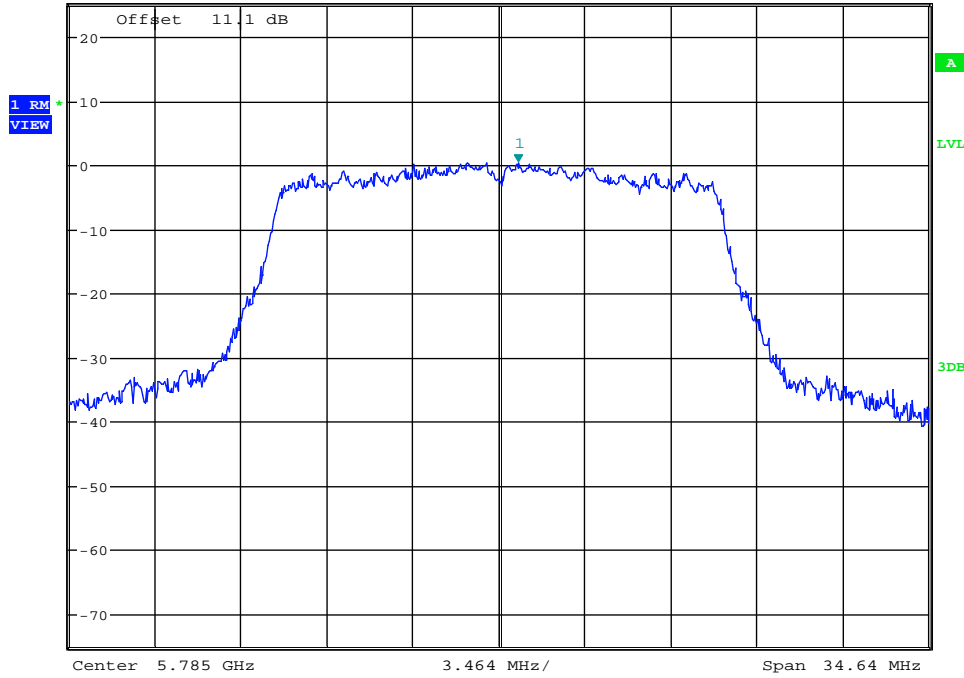

Date: 3.JAN.2018 14:26:23

### Maximum Power Spectral Density\_TNVN\_11N20SISO\_5825\_Ant1



Ref 25 dBm \* Att 20 dB \* RBW 500 kHz Marker 1 [T1 ] 0.18 dBm  
\* VBW 2 MHz SWT 20 ms 5.825848640 GHz

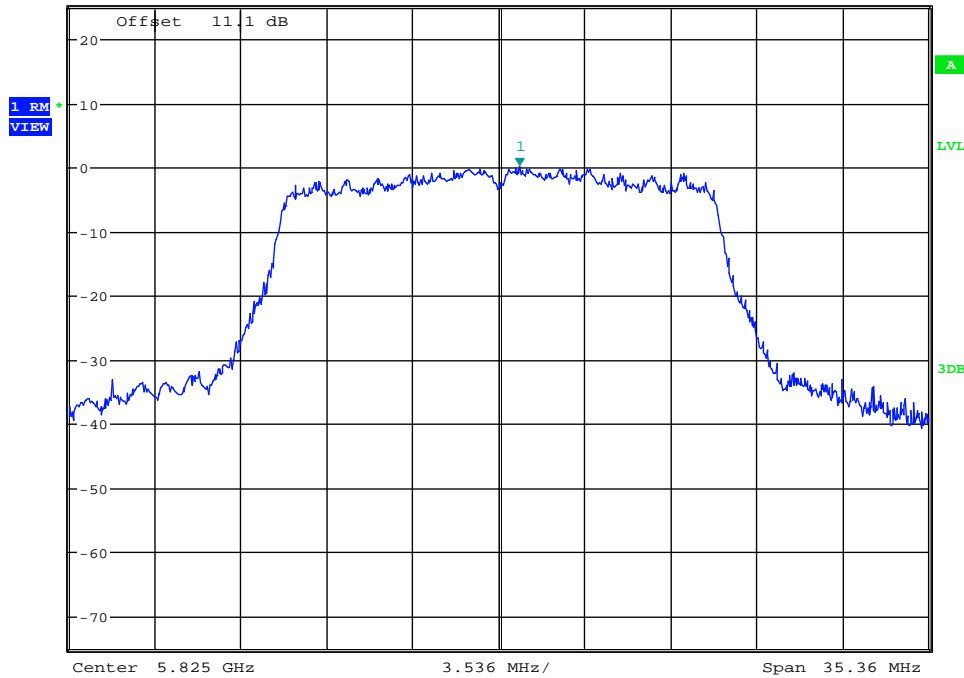

Date: 28.DEC.2017 21:29:11

### Maximum Power Spectral Density\_TNVN\_11N20SISO\_5825\_Ant2



Ref 25 dBm \* Att 20 dB \* RBW 500 kHz Marker 1 [T1 ] 0.33 dBm  
\* VBW 2 MHz 5.826063200 GHz  
SWT 20 ms

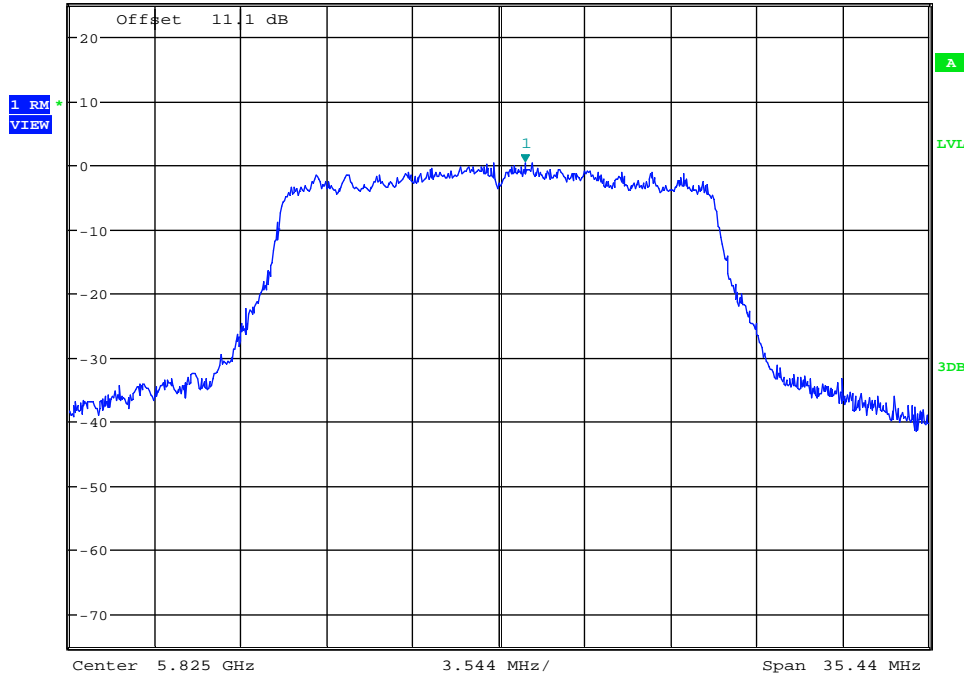

Date: 3.JAN.2018 14:30:36

Maximum Power Spectral Density\_TNVN\_11N40ISO\_5190\_Ant1



Ref 25 dBm \* Att 20 dB \* RBW 1 MHz Marker 1 [T1 ] -0.65 dBm  
\* VBW 3 MHz 5.191488000 GHz  
SWT 20 ms

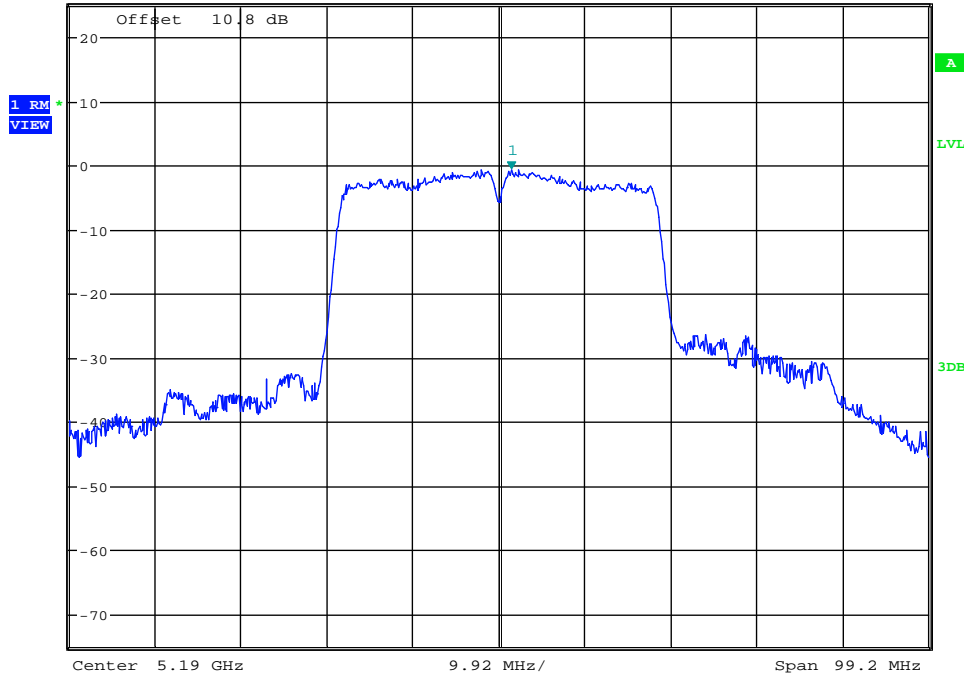

Date: 28.DEC.2017 21:35:19

Maximum Power Spectral Density\_TNVN\_11N40ISO\_5190\_Ant2



Ref 25 dBm \* Att 20 dB \* RBW 1 MHz Marker 1 [T1 ] -0.49 dBm  
\* VBW 3 MHz 5.191479680 GHz  
SWT 20 ms

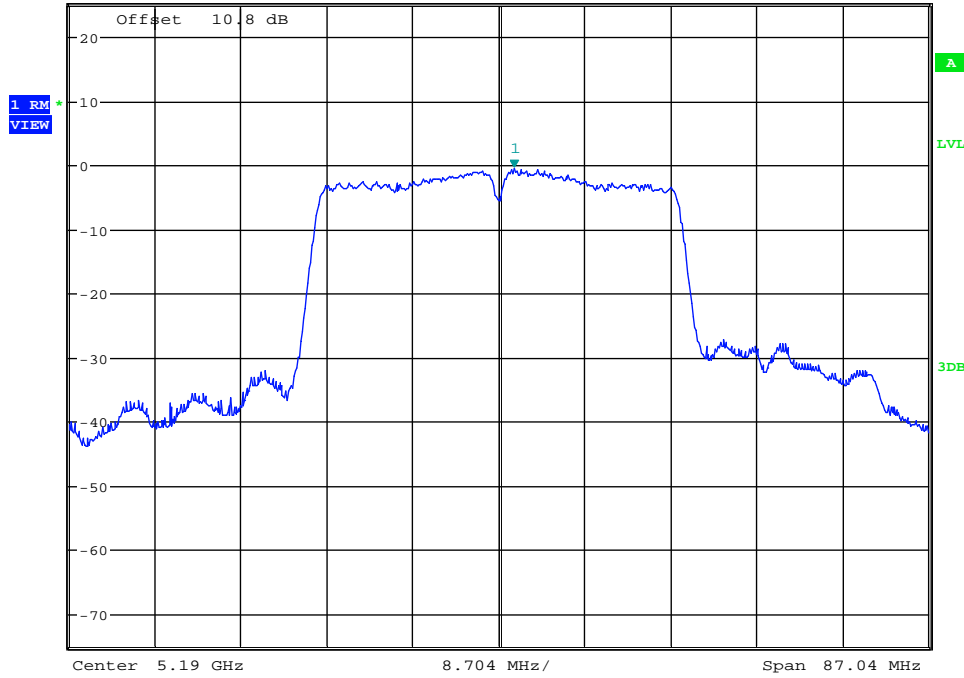

Date: 3.JAN.2018 14:36:01

Maximum Power Spectral Density\_TNVN\_11N40SISO\_5230\_Ant1



Ref 25 dBm \* Att 20 dB \* RBW 1 MHz Marker 1 [T1 ] -0.75 dBm  
\* VBW 3 MHz 5.231264640 GHz  
SWT 20 ms

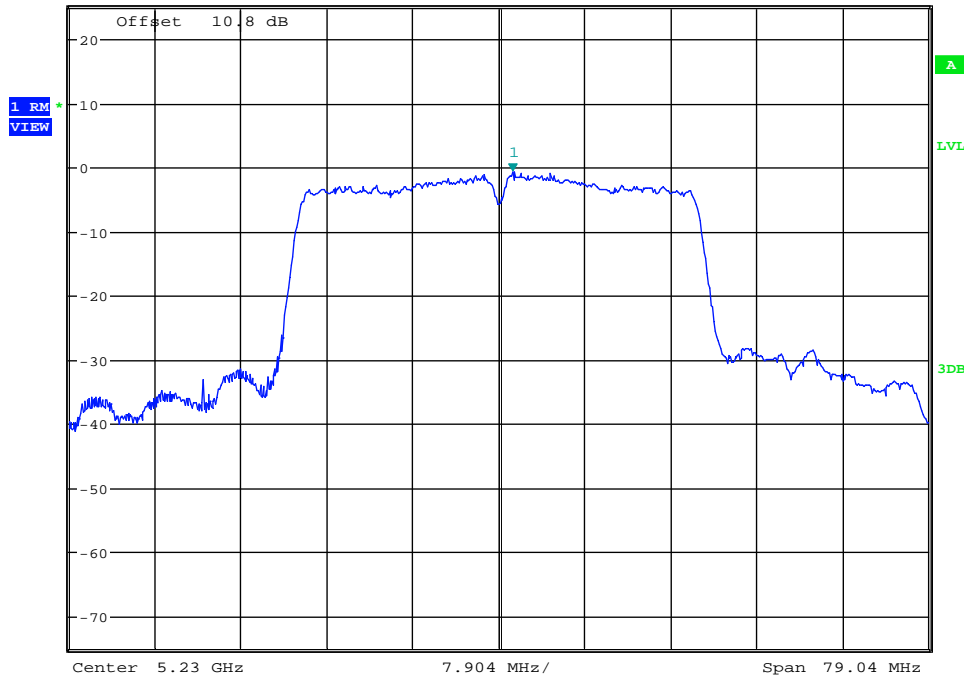

Date: 28.DEC.2017 21:40:26

Maximum Power Spectral Density\_TNVN\_11N40SISO\_5230\_Ant2

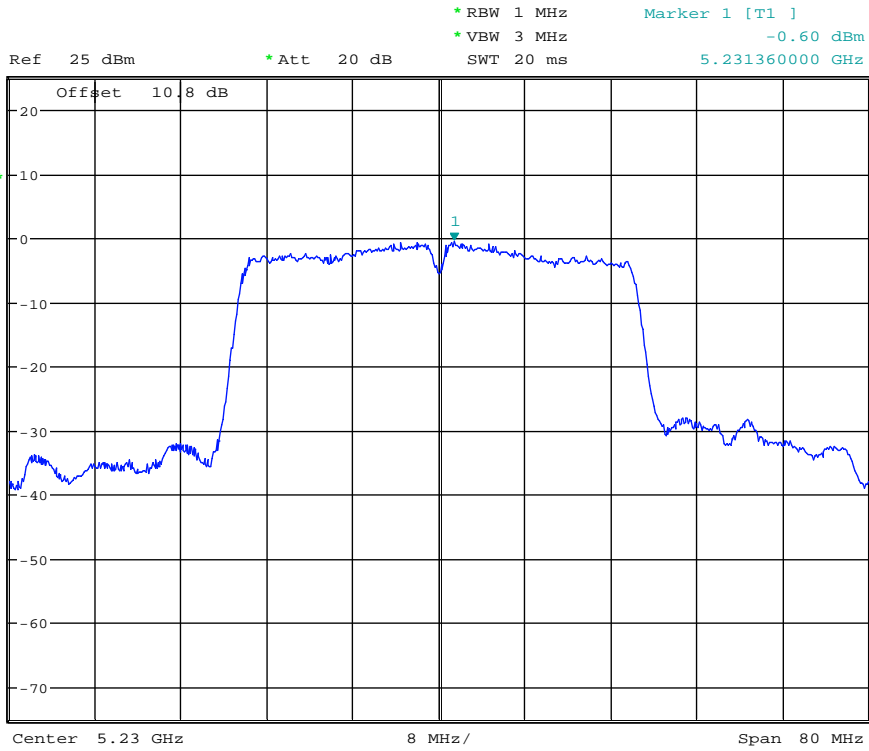

Date: 3.JAN.2018 14:42:21

Maximum Power Spectral Density\_TNVN\_11N40ISO\_5270\_Ant1

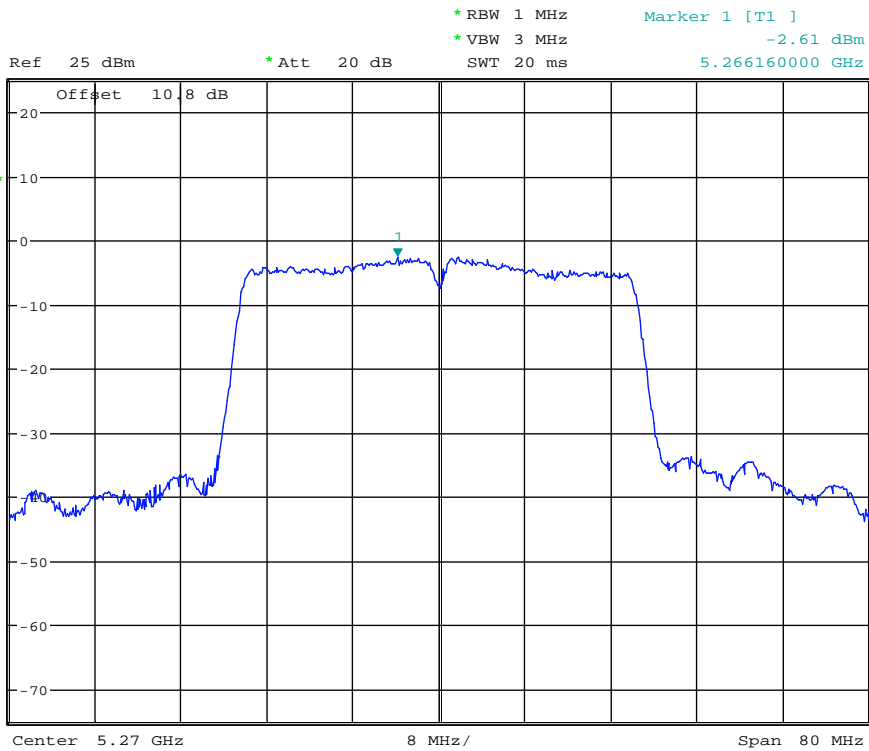

Date: 28.DEC.2017 21:47:08

Maximum Power Spectral Density\_TNVN\_11N40ISO\_5270\_Ant2

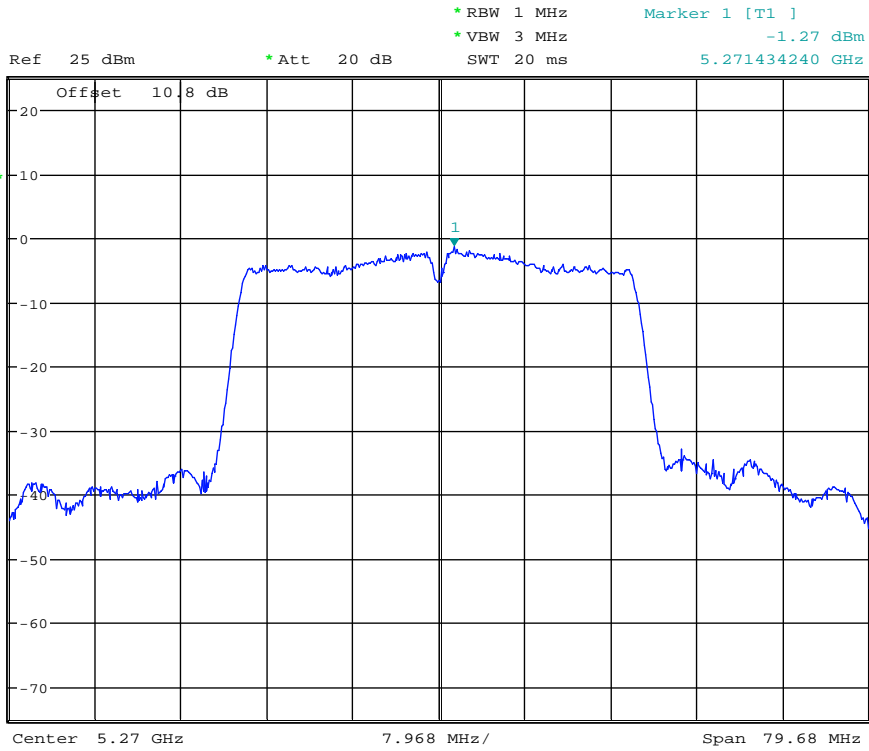

Date: 3.JAN.2018 14:47:25

Maximum Power Spectral Density\_TNVN\_11N40SISO\_5310\_Ant1

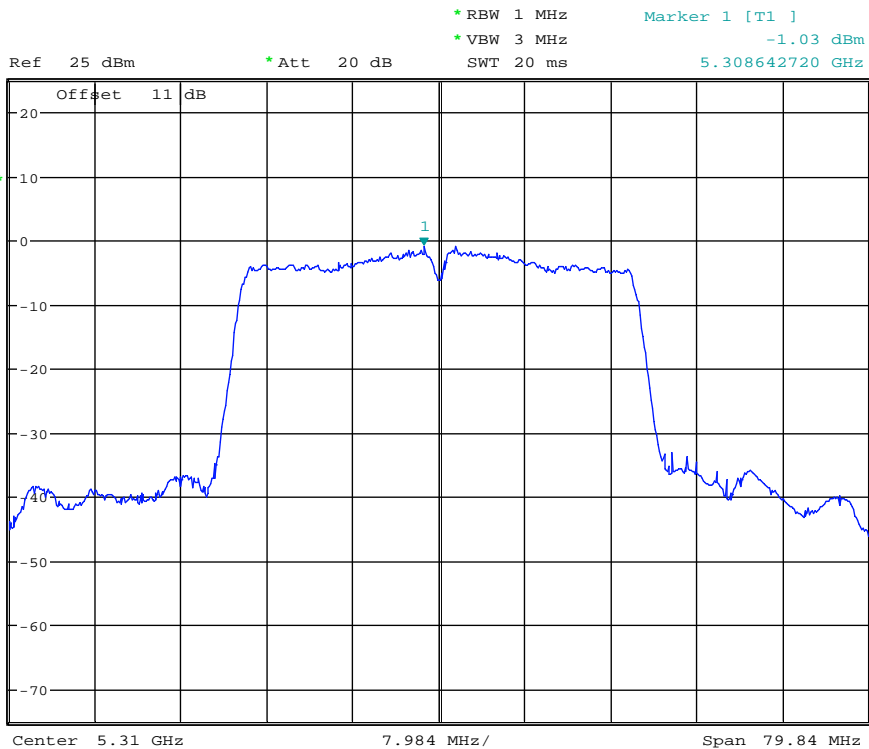

Date: 28.DEC.2017 21:51:55

Maximum Power Spectral Density\_TNVN\_11N40SISO\_5310\_Ant2



Ref 25 dBm      \* Att 20 dB      \* RBW 1 MHz      Marker 1 [T1 ]  
\* VBW 3 MHz      -0.94 dBm  
SWT 20 ms      5.311354560 GHz

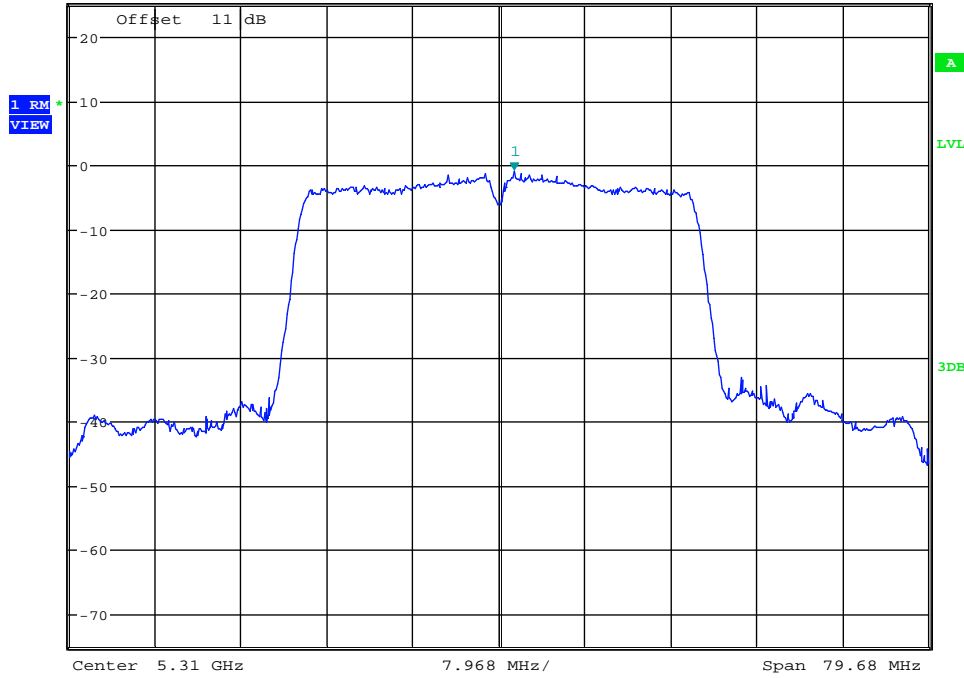

Date: 3.JAN.2018 14:52:15

Maximum Power Spectral Density\_TNVN\_11N40ISO\_5510\_Ant1



Ref 25 dBm      \* Att 20 dB      \* RBW 1 MHz      Marker 1 [T1 ]  
\* VBW 3 MHz      -0.23 dBm  
SWT 20 ms      5.508648160 GHz

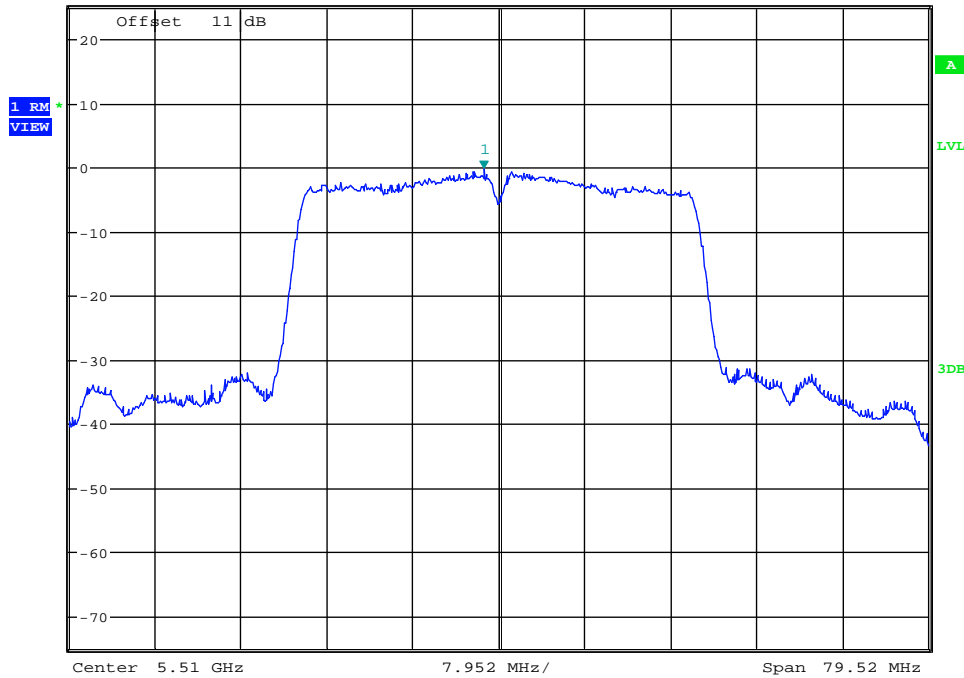

Date: 28.DEC.2017 21:57:44

Maximum Power Spectral Density\_TNVN\_11N40ISO\_5510\_Ant2



Ref 25 dBm \* Att 20 dB \* RBW 1 MHz Marker 1 [T1 ] -0.78 dBm  
\* VBW 3 MHz 5.511267200 GHz  
SWT 20 ms

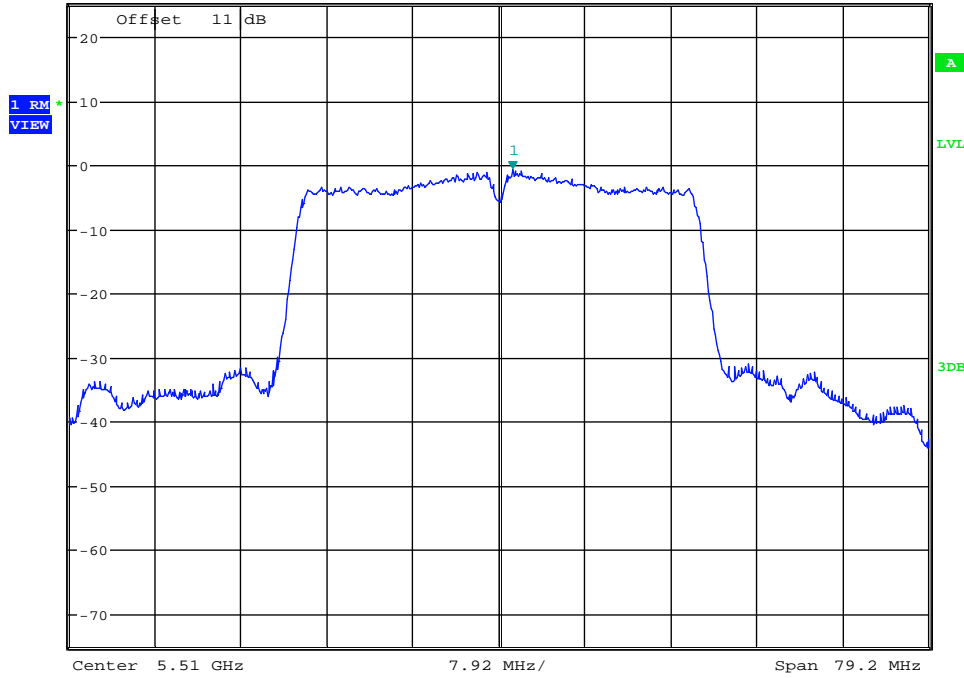

Date: 3.JAN.2018 14:57:11

Maximum Power Spectral Density\_TNVN\_11N40ISO\_5550\_Ant1



Ref 25 dBm \* Att 20 dB \* RBW 1 MHz Marker 1 [T1 ] -1.42 dBm  
\* VBW 3 MHz 5.548403200 GHz  
SWT 20 ms

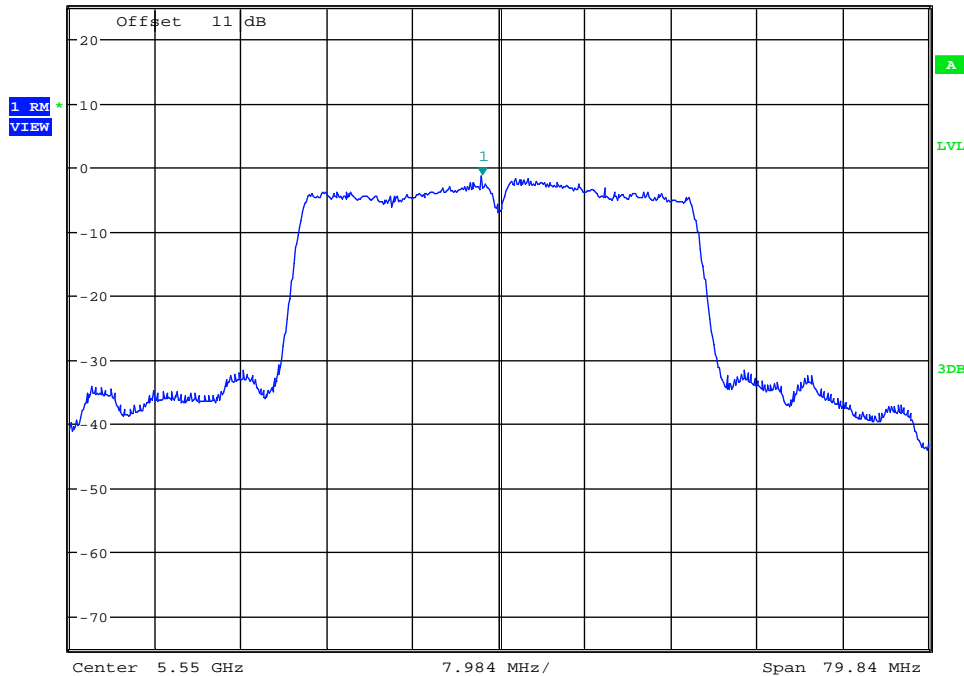

Date: 28.DEC.2017 22:02:27

Maximum Power Spectral Density\_TNVN\_11N40ISO\_5550\_Ant2

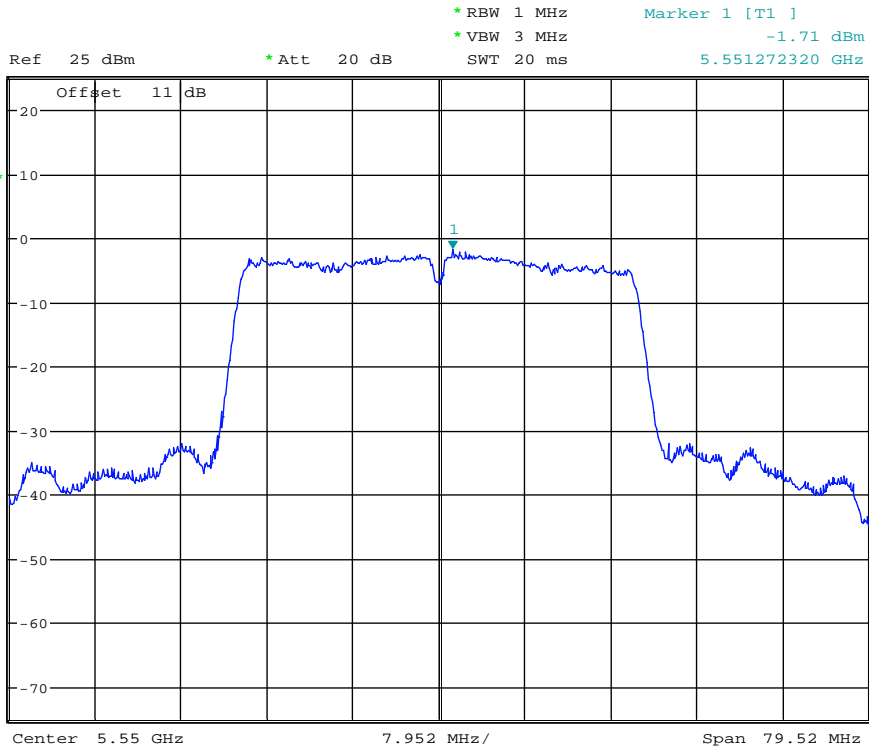

Date: 3.JAN.2018 15:03:03

Maximum Power Spectral Density\_TNVN\_11N40SISO\_5670\_Ant1

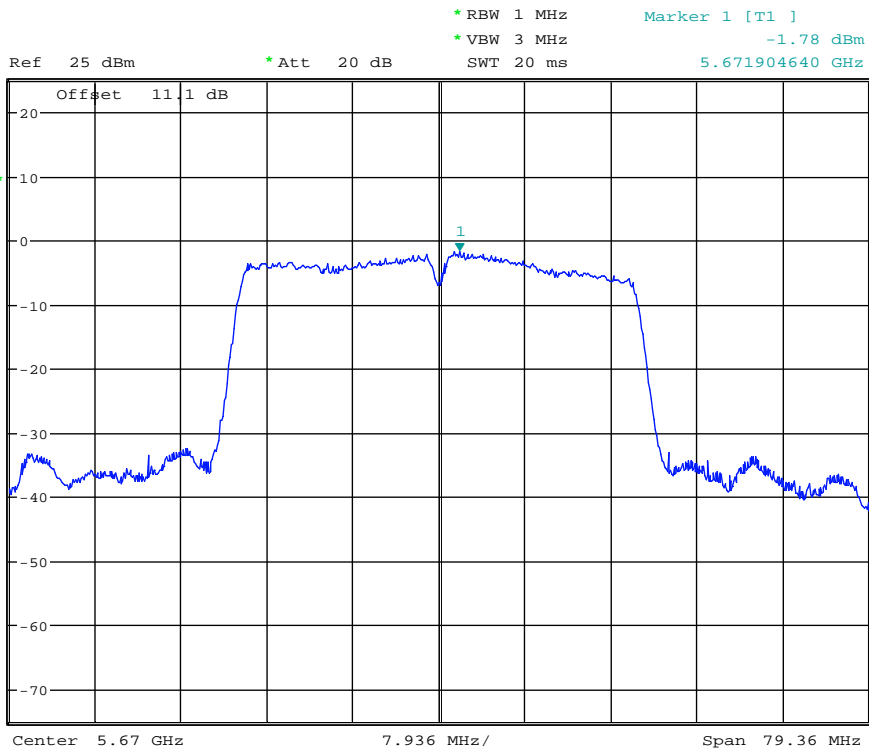

Date: 28.DEC.2017 22:08:05

Maximum Power Spectral Density\_TNVN\_11N40SISO\_5670\_Ant2

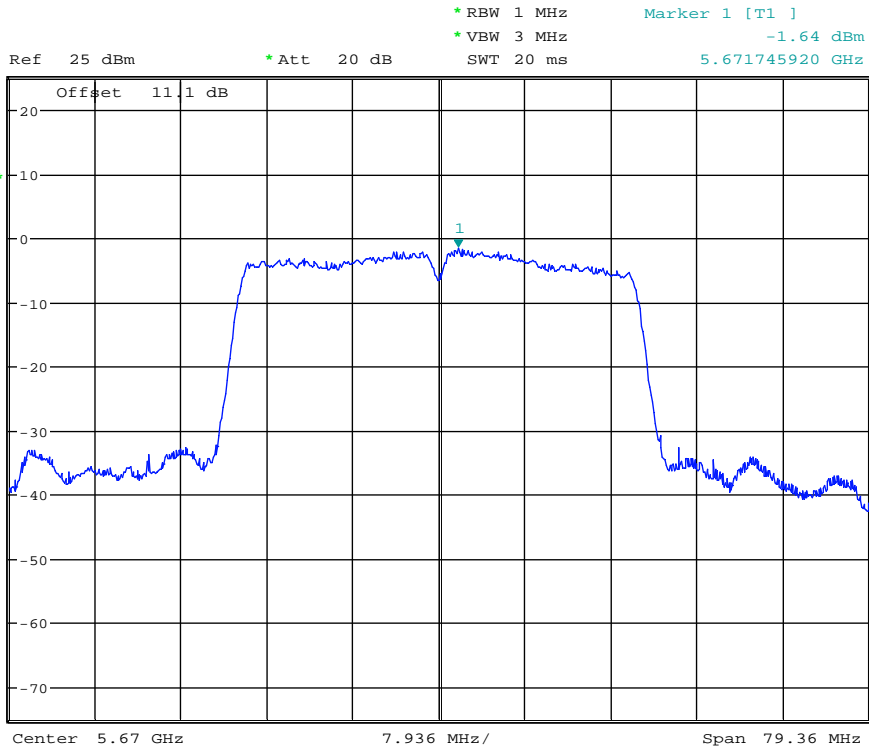

Date: 3.JAN.2018 15:07:09

Maximum Power Spectral Density\_TNVN\_11N40ISO\_5755\_Ant1

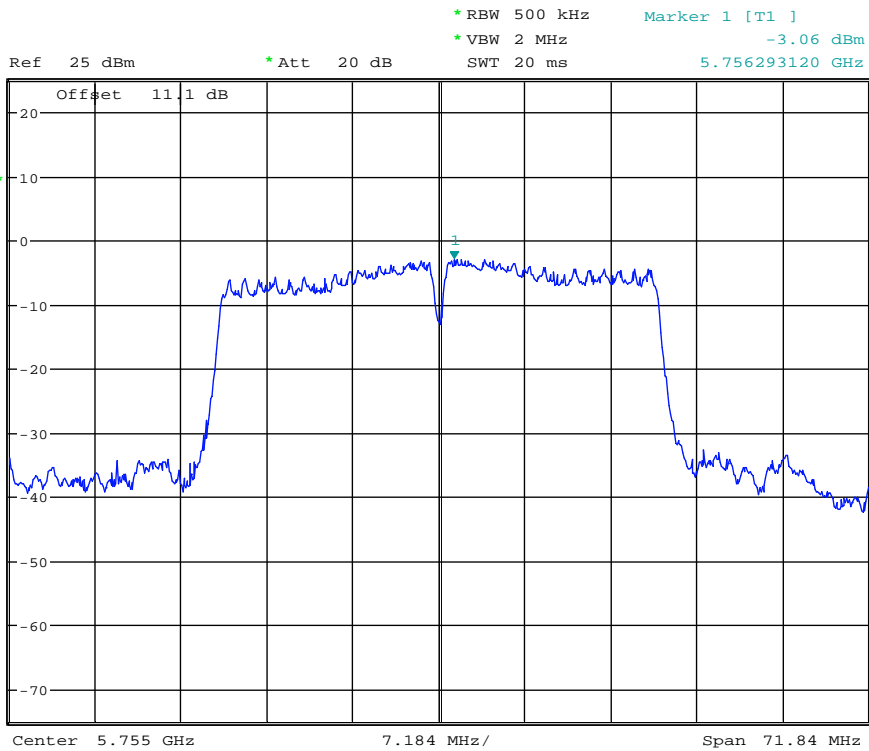

Date: 28.DEC.2017 22:12:44

Maximum Power Spectral Density\_TNVN\_11N40ISO\_5755\_Ant2



Ref 25 dBm \* Att 20 dB \* RBW 500 kHz Marker 1 [T1 ]  
\* VBW 2 MHz -2.68 dBm  
SWT 20 ms 5.755871680 GHz

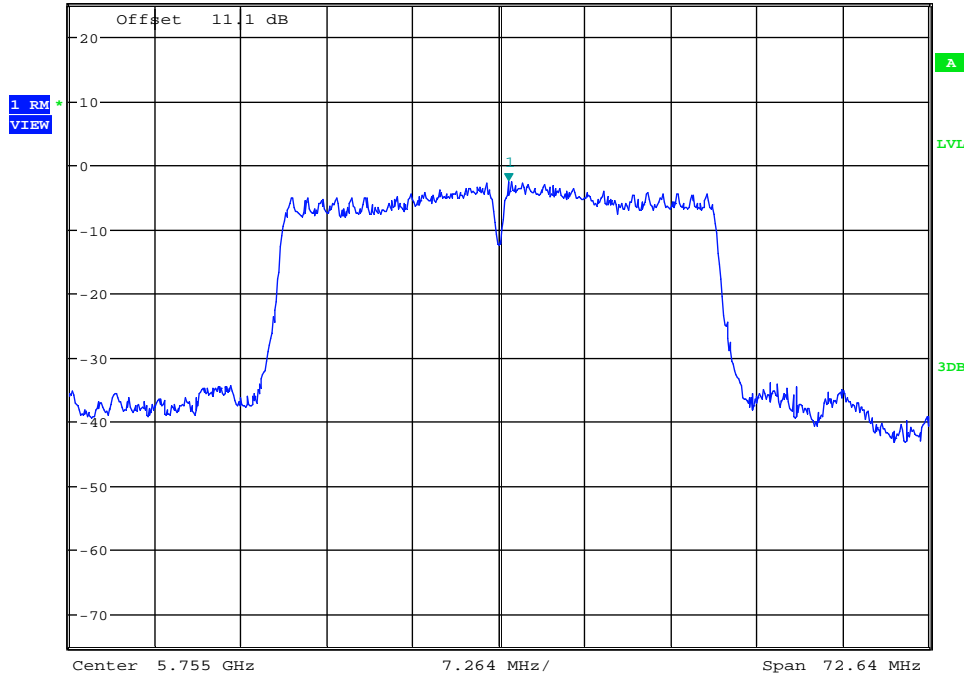

Date: 3.JAN.2018 15:12:30

Maximum Power Spectral Density\_TNVN\_11N40SISO\_5795\_Ant1



Ref 25 dBm \* Att 20 dB \* RBW 500 kHz Marker 1 [T1 ]  
\* VBW 2 MHz -2.37 dBm  
SWT 20 ms 5.796459200 GHz

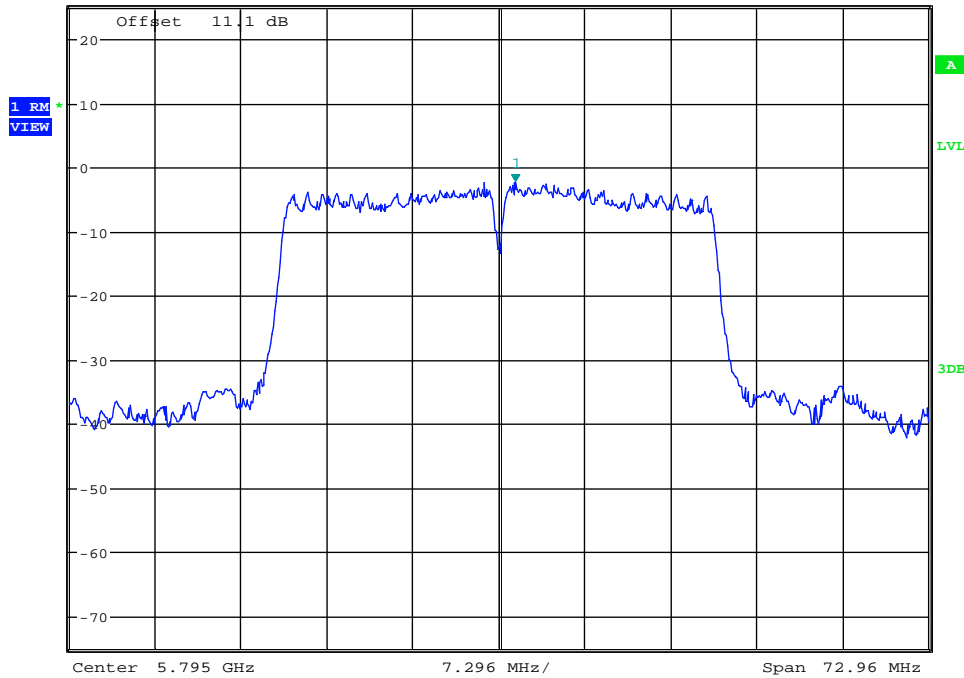

Date: 28.DEC.2017 22:21:45

Maximum Power Spectral Density\_TNVN\_11N40SISO\_5795\_Ant2



Ref 25 dBm      \* Att 20 dB      \* RBW 500 kHz      Marker 1 [T1 ]      -2.61 dBm  
\* VBW 2 MHz      SWT 20 ms      5.796167360 GHz

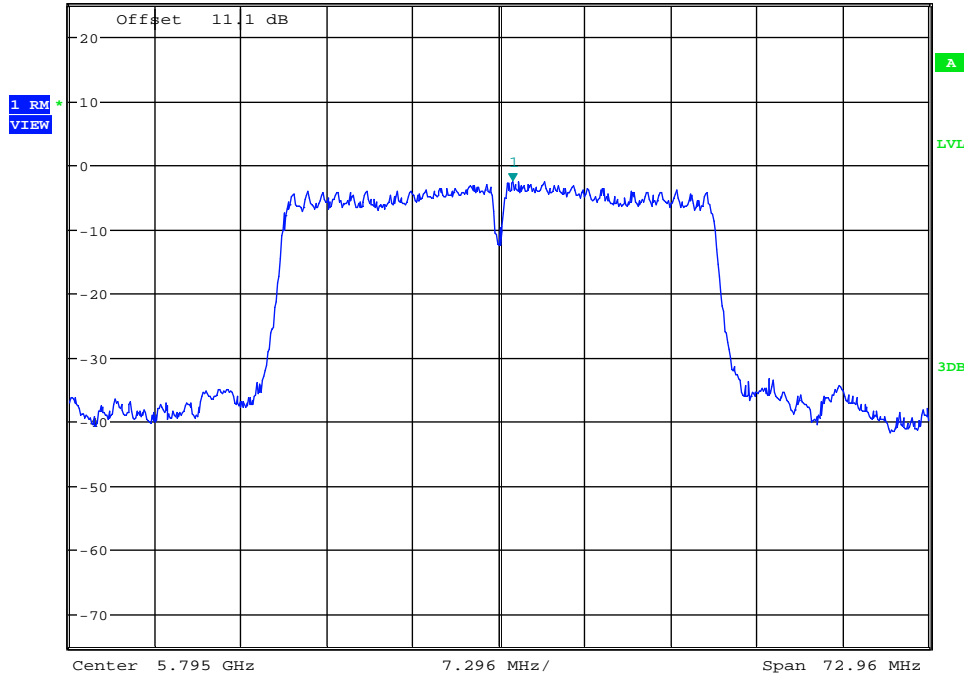

Date: 3.JAN.2018 15:17:39

Maximum Power Spectral Density\_TNVN\_11AC20SISO\_5180\_Ant1



Ref 25 dBm      \* Att 20 dB      \* RBW 1 MHz      Marker 1 [T1 ]      3.18 dBm  
\* VBW 3 MHz      SWT 20 ms      5.178930000 GHz

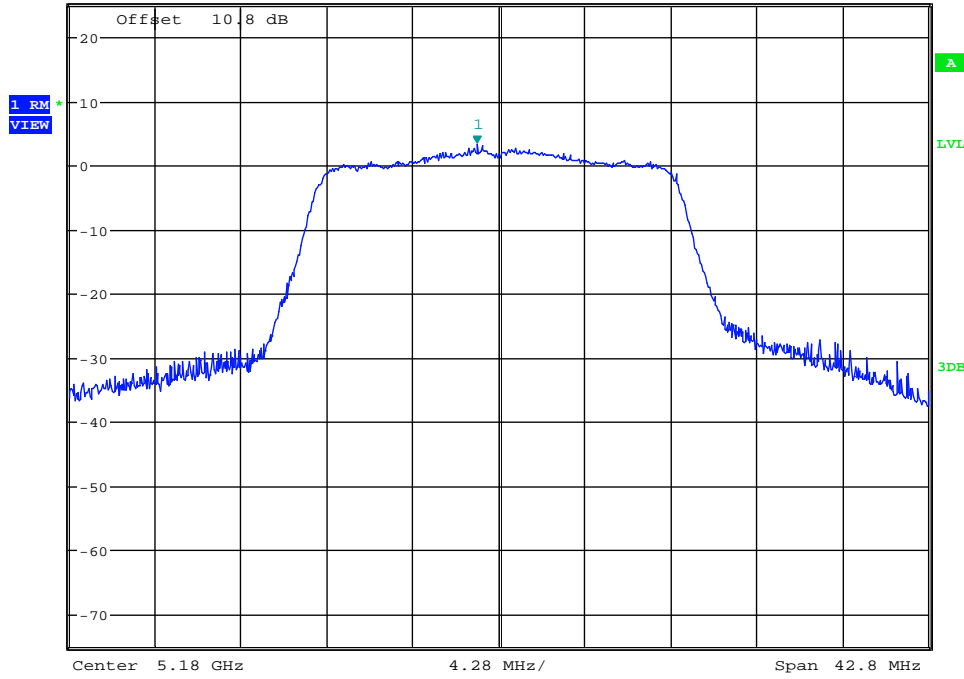

Date: 29.DEC.2017 19:45:17

Maximum Power Spectral Density\_TNVN\_11AC20SISO\_5180\_Ant2

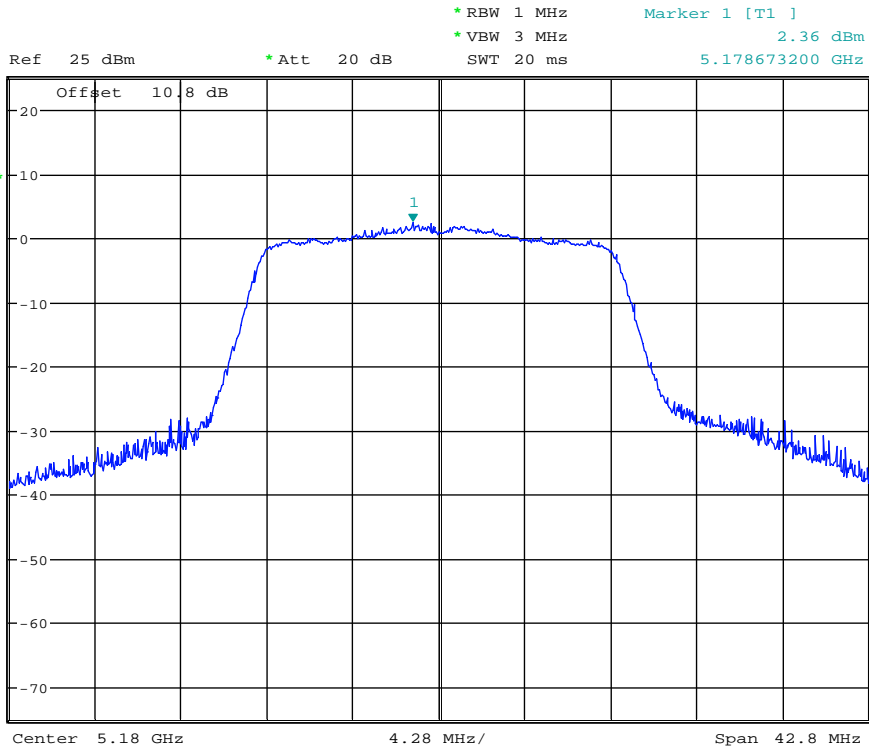

Date: 3.JAN.2018 15:22:47

Maximum Power Spectral Density\_TNVN\_11AC20SISO\_5200\_Ant1

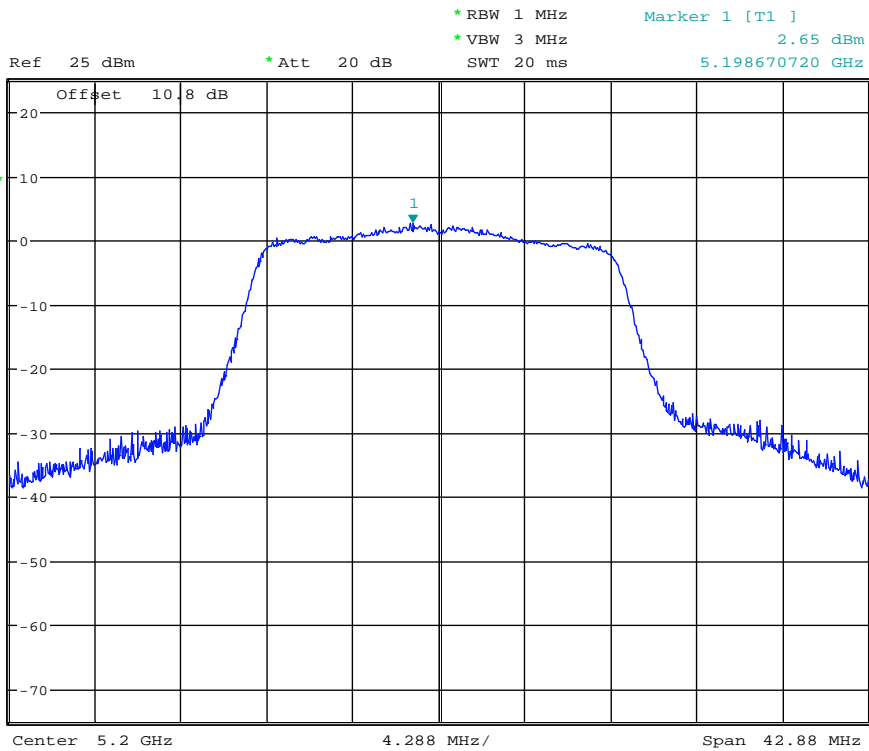

Date: 29.DEC.2017 20:00:44

Maximum Power Spectral Density\_TNVN\_11AC20SISO\_5200\_Ant2



Ref 25 dBm      \* Att 20 dB      \* RBW 1 MHz      Marker 1 [T1 ]      2.61 dBm  
\* VBW 3 MHz      5.199266960 GHz  
SWT 20 ms

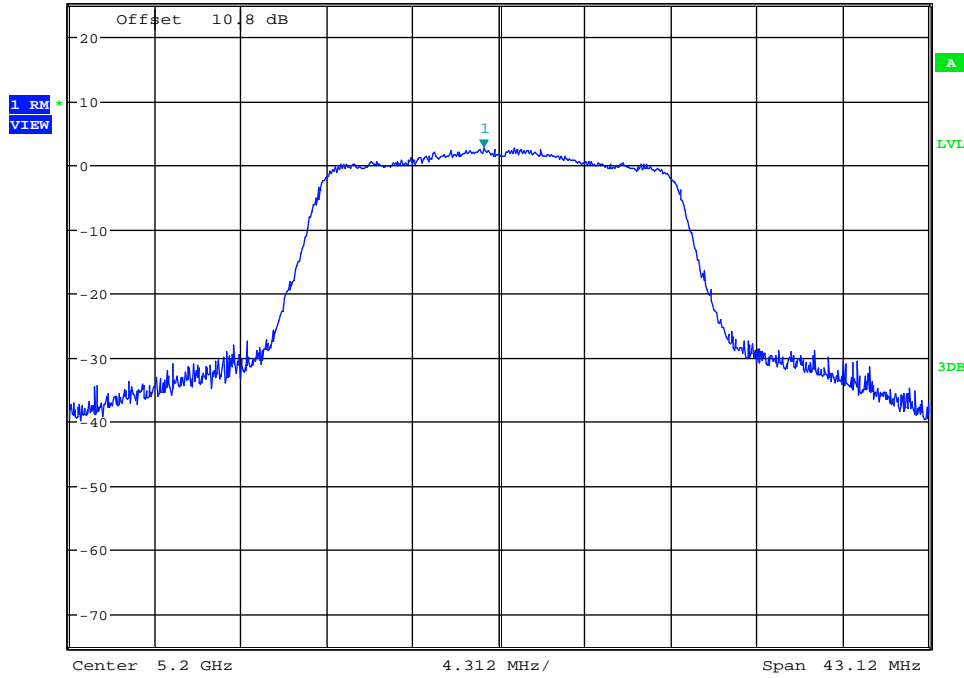

Date: 3.JAN.2018 15:27:58

Maximum Power Spectral Density\_TNVN\_11AC20SISO\_5240\_Ant1



Ref 25 dBm      \* Att 20 dB      \* RBW 1 MHz      Marker 1 [T1 ]      2.84 dBm  
\* VBW 3 MHz      5.242085440 GHz  
SWT 20 ms

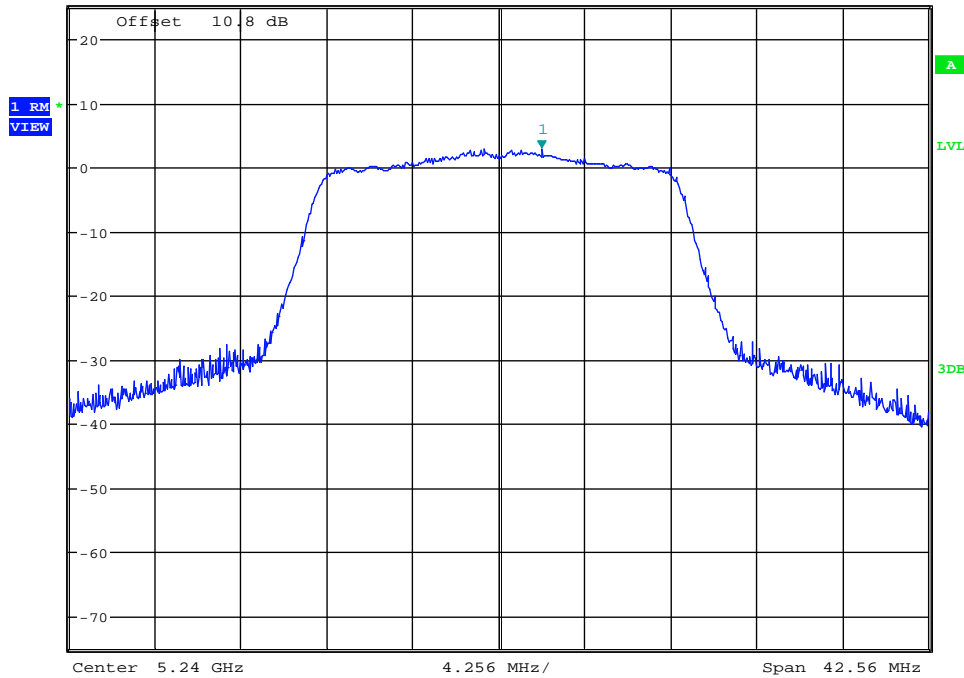

Date: 29.DEC.2017 20:05:51

Maximum Power Spectral Density\_TNVN\_11AC20SISO\_5240\_Ant2



Ref 25 dBm \* Att 20 dB \* RBW 1 MHz Marker 1 [T1 ] 2.41 dBm  
\* VBW 3 MHz 5.239185280 GHz  
SWT 20 ms

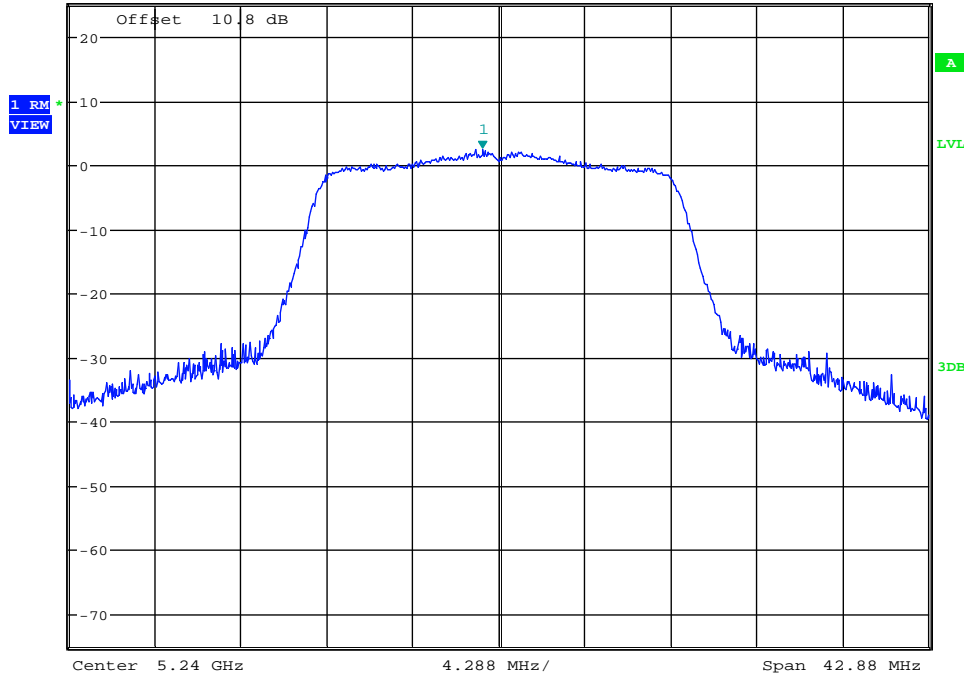

Date: 3.JAN.2018 15:32:58

Maximum Power Spectral Density\_TNVN\_11AC20SISO\_5260\_Ant1



Ref 25 dBm \* Att 20 dB \* RBW 1 MHz Marker 1 [T1 ] -1.53 dBm  
\* VBW 3 MHz 5.259573600 GHz  
SWT 20 ms

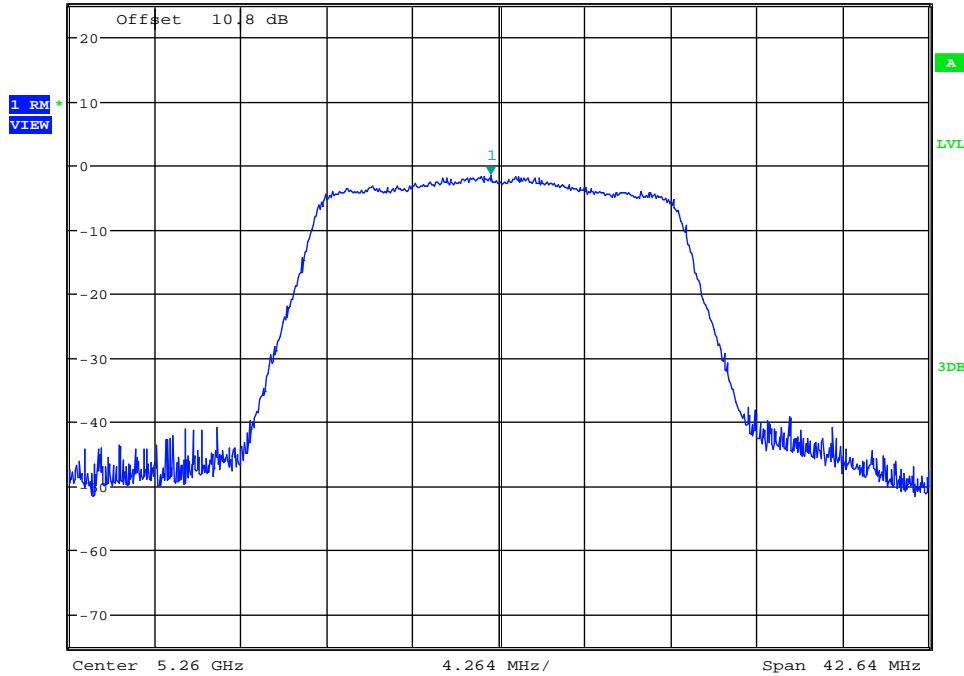

Date: 29.DEC.2017 20:11:06

Maximum Power Spectral Density\_TNVN\_11AC20SISO\_5260\_Ant2



Ref 25 dBm \* Att 20 dB \* RBW 1 MHz Marker 1 [T1 ] -1.36 dBm  
\* VBW 3 MHz 5.259104560 GHz  
SWT 20 ms

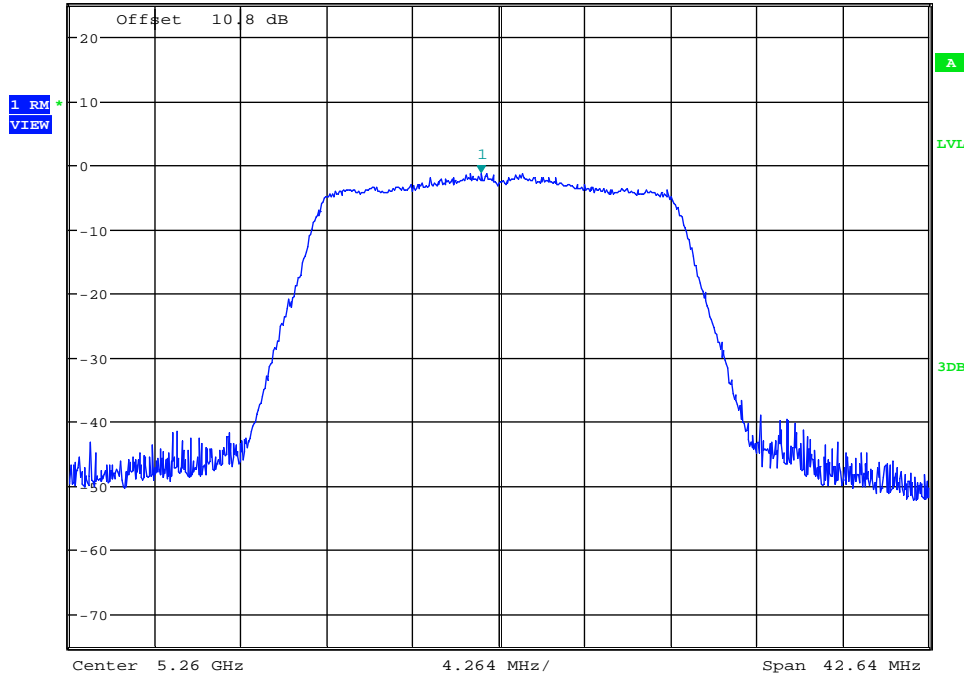

Date: 3.JAN.2018 15:38:41

Maximum Power Spectral Density\_TNVN\_11AC20SISO\_5280\_Ant1



Ref 25 dBm \* Att 20 dB \* RBW 1 MHz Marker 1 [T1 ] -1.48 dBm  
\* VBW 3 MHz 5.279106240 GHz  
SWT 20 ms

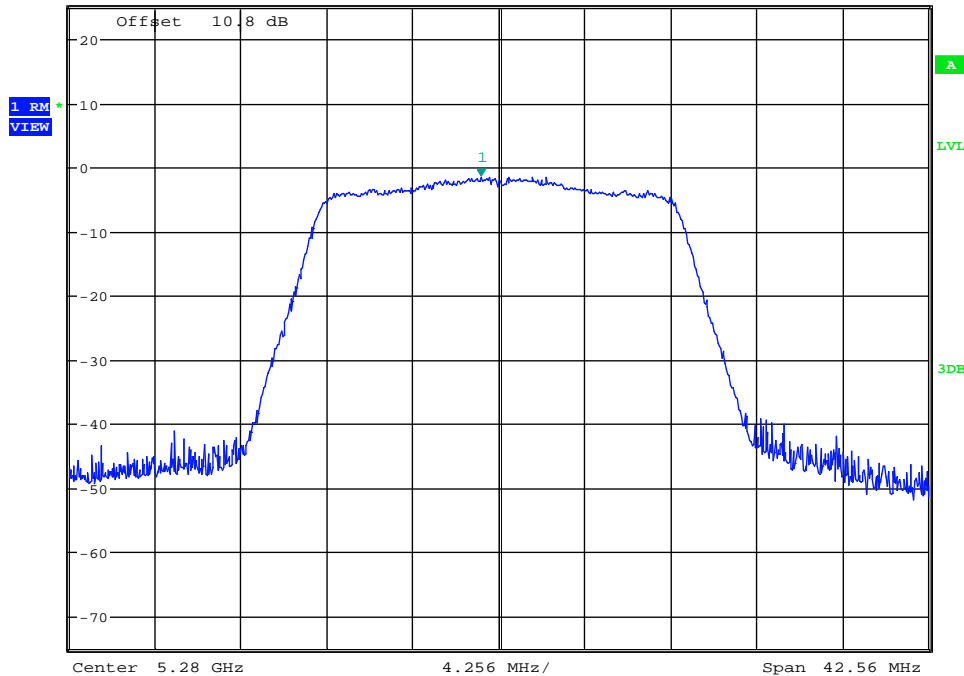

Date: 29.DEC.2017 20:16:56

Maximum Power Spectral Density\_TNVN\_11AC20SISO\_5280\_Ant2

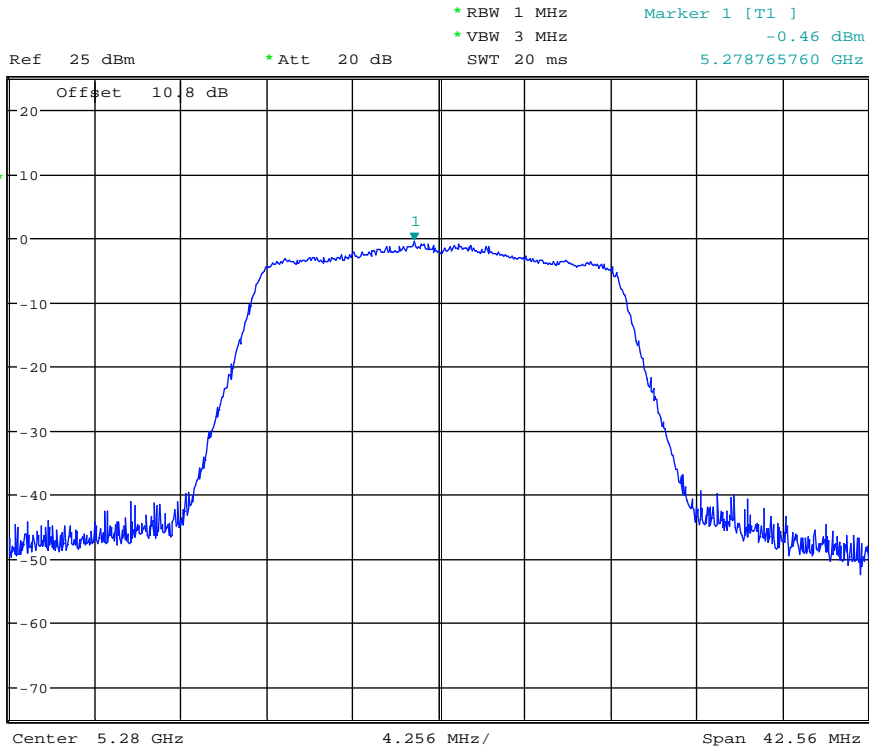

Date: 3.JAN.2018 15:44:05

Maximum Power Spectral Density\_TNVN\_11AC20SISO\_5320\_Ant1

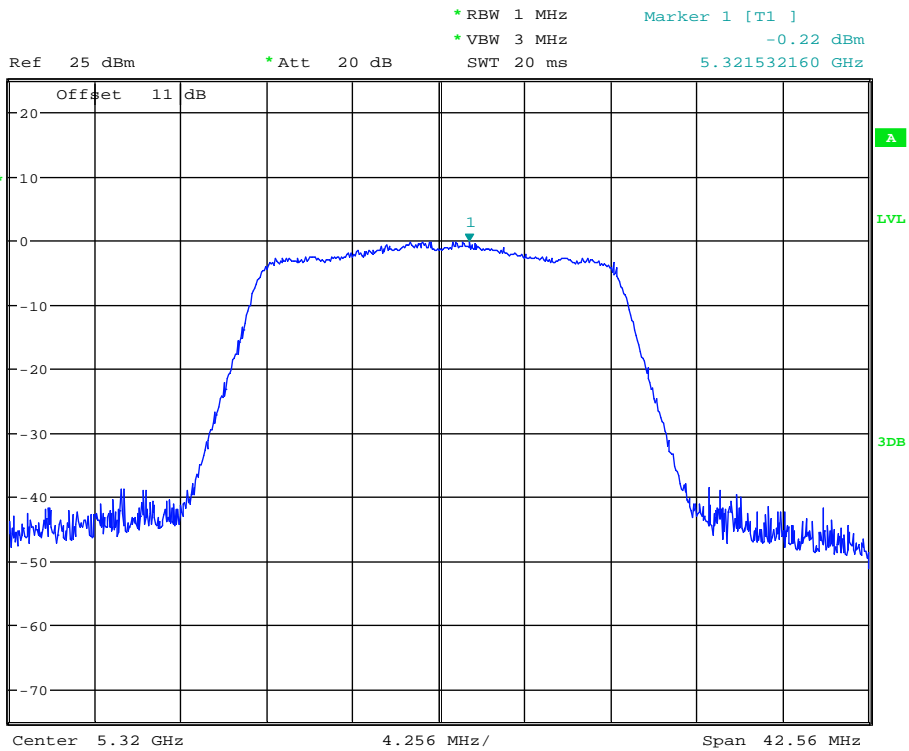

Date: 29.DEC.2017 20:22:15

Maximum Power Spectral Density\_TNVN\_11AC20SISO\_5320\_Ant2



Ref 25 dBm      \* Att 20 dB      \* RBW 1 MHz      Marker 1 [T1 ]      0.48 dBm  
\* VBW 3 MHz      5.321234240 GHz  
SWT 20 ms

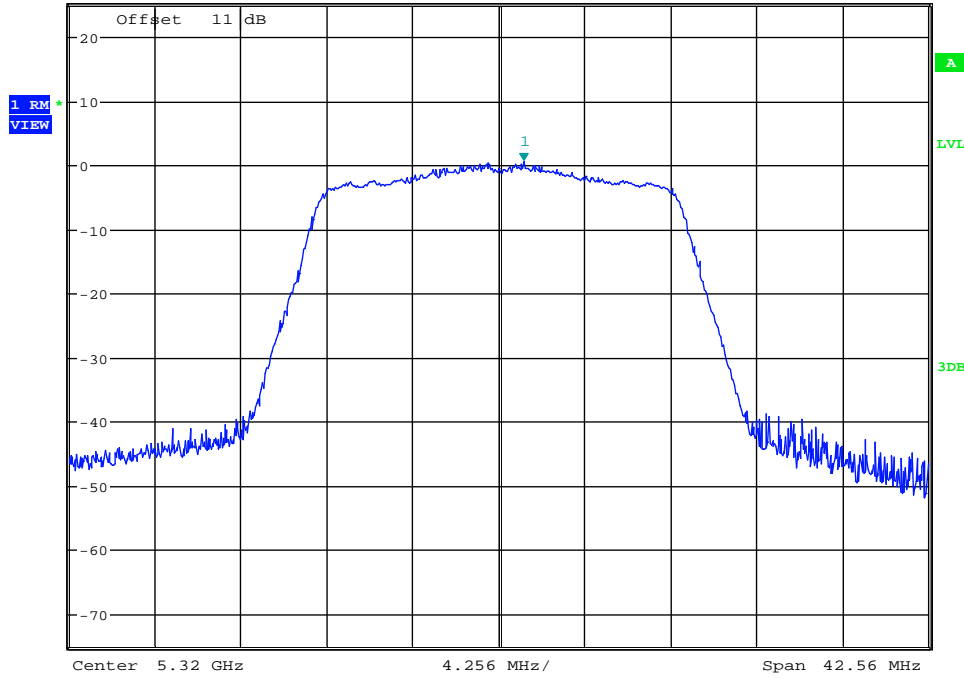

Date: 3.JAN.2018 15:51:28

Maximum Power Spectral Density\_TNVN\_11AC20SISO\_5500\_Ant1



Ref 25 dBm      \* Att 20 dB      \* RBW 1 MHz      Marker 1 [T1 ]      2.94 dBm  
\* VBW 3 MHz      5.501112800 GHz  
SWT 20 ms

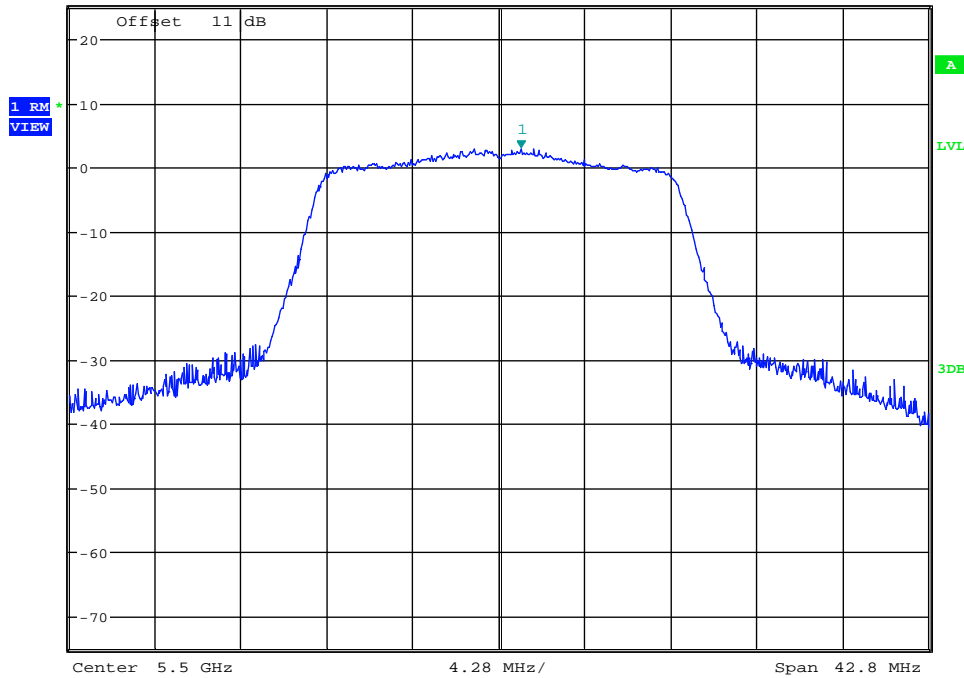

Date: 29.DEC.2017 20:27:53

Maximum Power Spectral Density\_TNVN\_11AC20SISO\_5500\_Ant2



Ref 25 dBm \* Att 20 dB \* RBW 1 MHz Marker 1 [T1 ] 1.86 dBm  
\* VBW 3 MHz 5.500807120 GHz  
SWT 20 ms

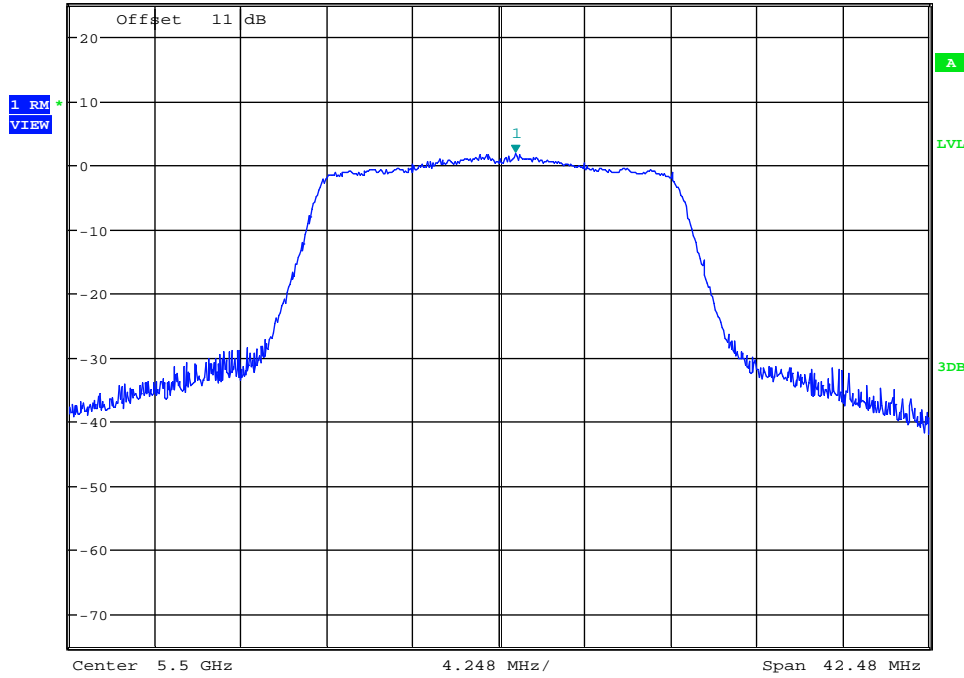

Date: 3.JAN.2018 16:05:35

Maximum Power Spectral Density\_TNVN\_11AC20SISO\_5580\_Ant1



Ref 25 dBm \* Att 20 dB \* RBW 1 MHz Marker 1 [T1 ] 1.50 dBm  
\* VBW 3 MHz 5.579232480 GHz  
SWT 20 ms

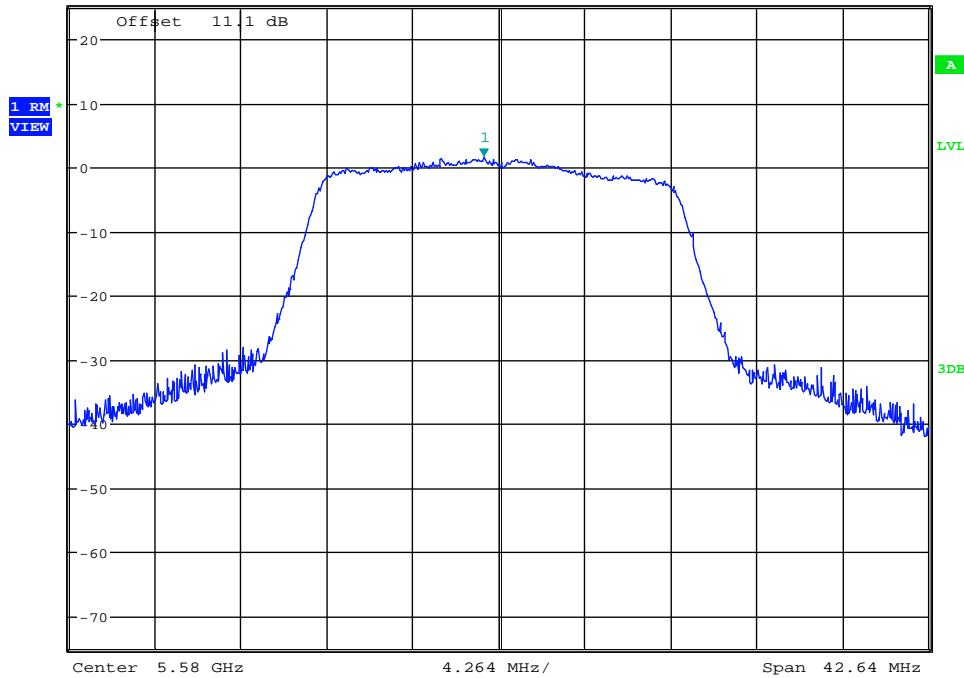

Date: 29.DEC.2017 20:35:32

Maximum Power Spectral Density\_TNVN\_11AC20SISO\_5580\_Ant2

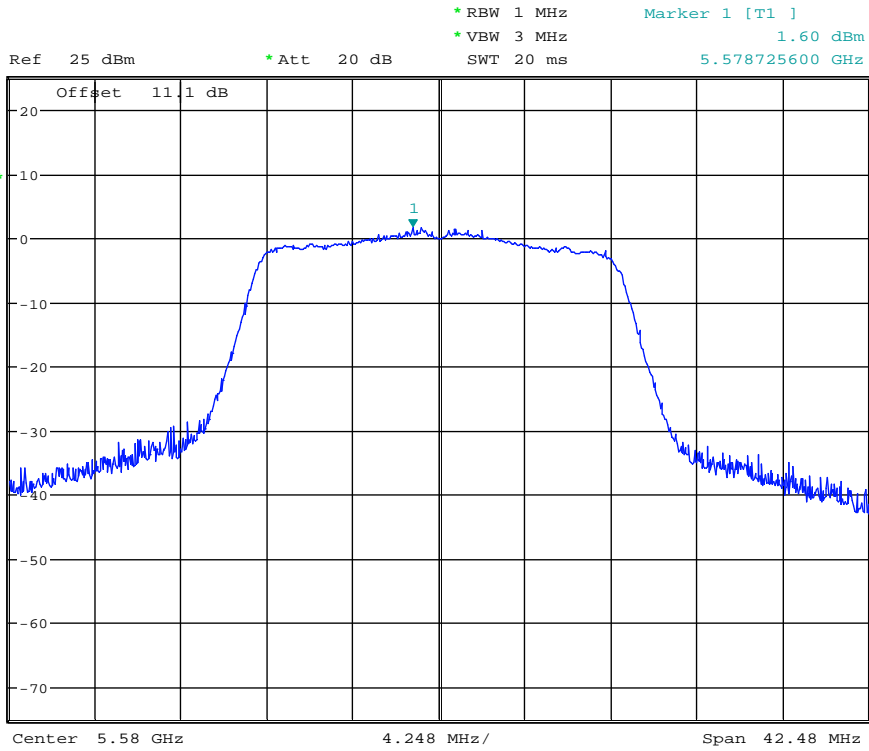

Date: 3.JAN.2018 16:10:36

Maximum Power Spectral Density\_TNVN\_11AC20SISO\_5700\_Ant1

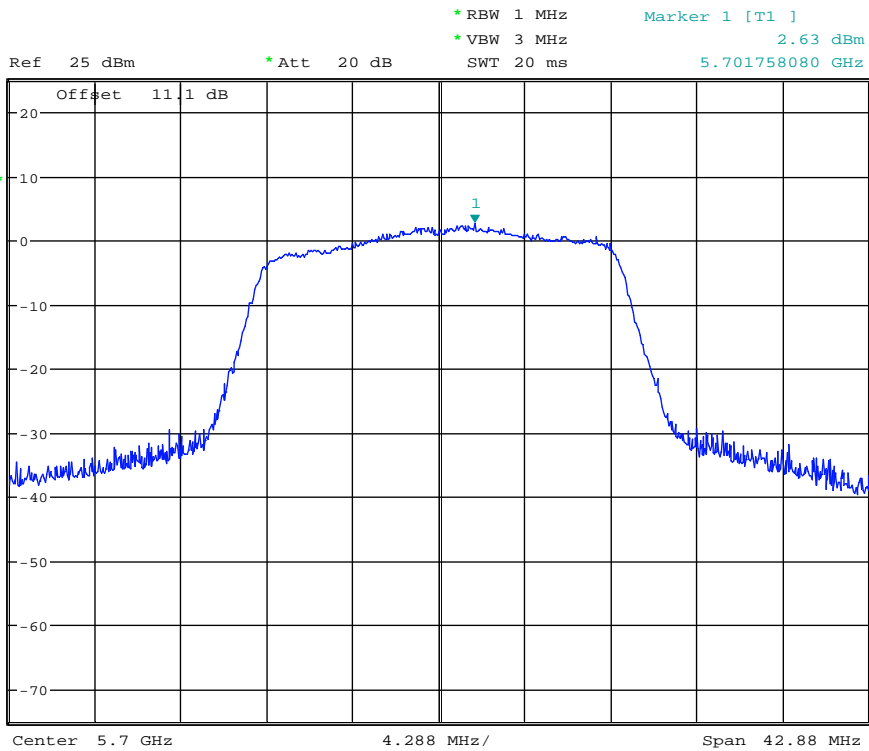

Date: 29.DEC.2017 20:41:31

Maximum Power Spectral Density\_TNVN\_11AC20SISO\_5700\_Ant2

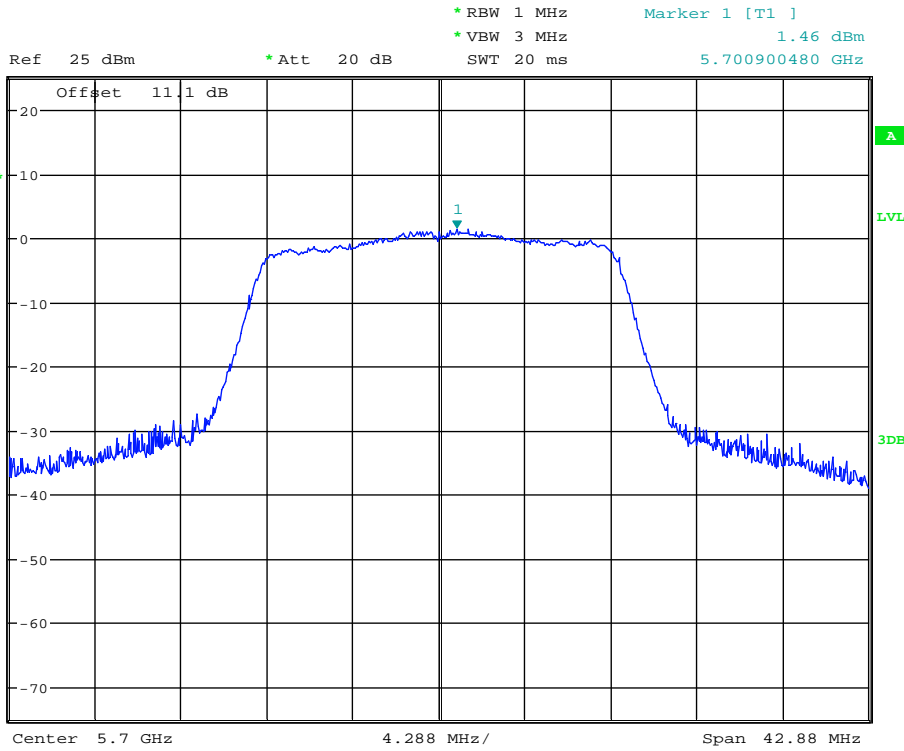

Date: 3.JAN.2018 16:15:26

Maximum Power Spectral Density\_TNVN\_11AC20SISO\_5745\_Ant1

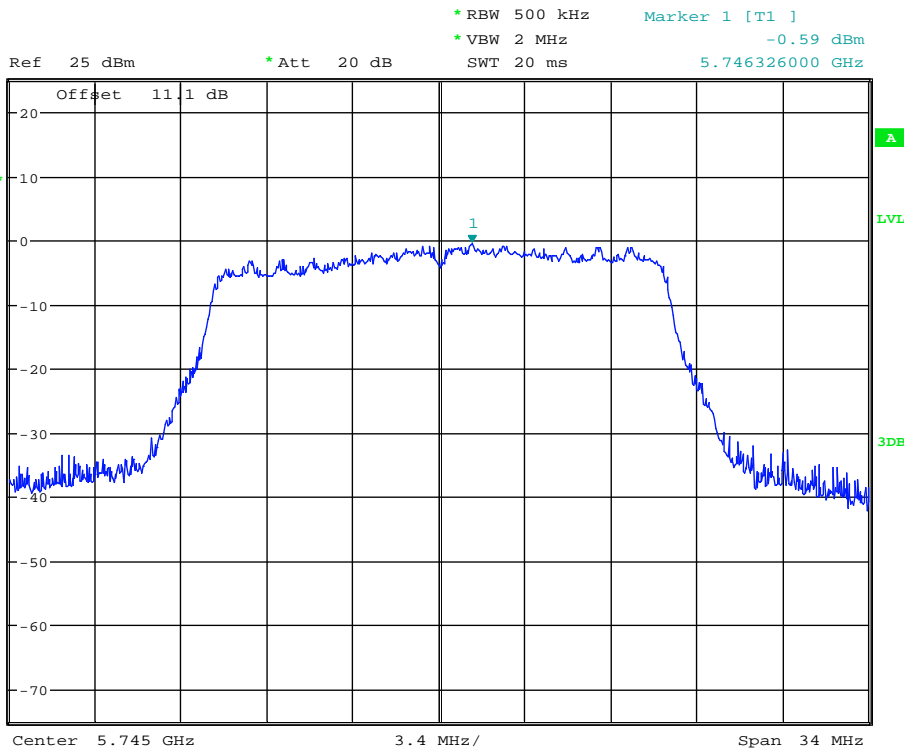

Date: 29.DEC.2017 20:46:40

Maximum Power Spectral Density\_TNVN\_11AC20SISO\_5745\_Ant2



Ref 25 dBm \* Att 20 dB \* RBW 500 kHz Marker 1 [T1 ] \* VBW 2 MHz -0.12 dBm  
SWT 20 ms 5.746701120 GHz

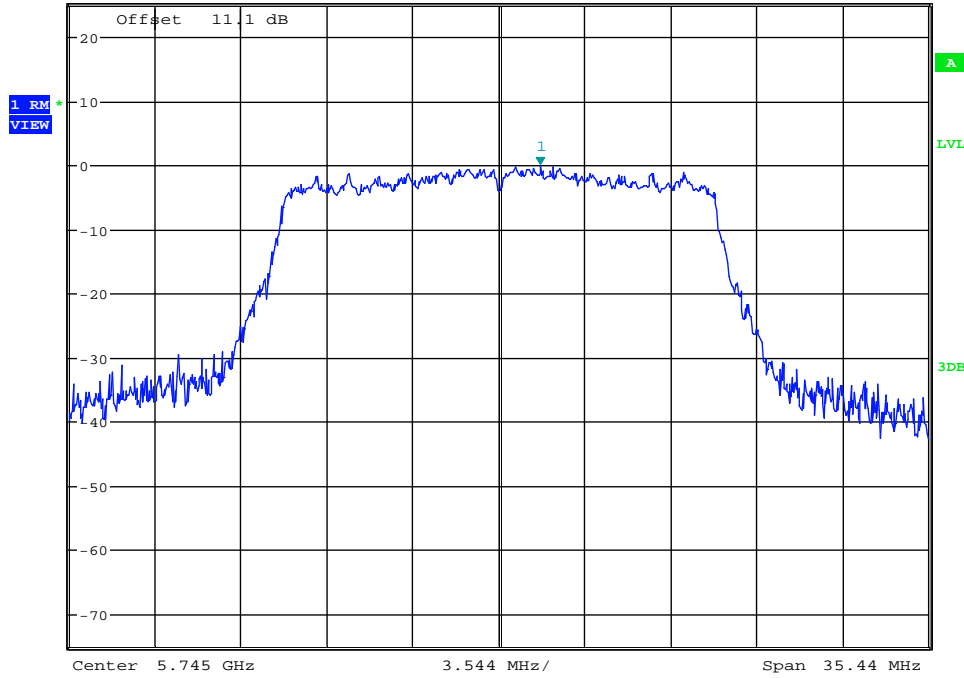

Date: 3.JAN.2018 16:26:54

Maximum Power Spectral Density\_TNVN\_11AC20SISO\_5785\_Ant1



Ref 25 dBm \* Att 20 dB \* RBW 500 kHz Marker 1 [T1 ] \* VBW 2 MHz 0.68 dBm  
SWT 20 ms 5.784435520 GHz

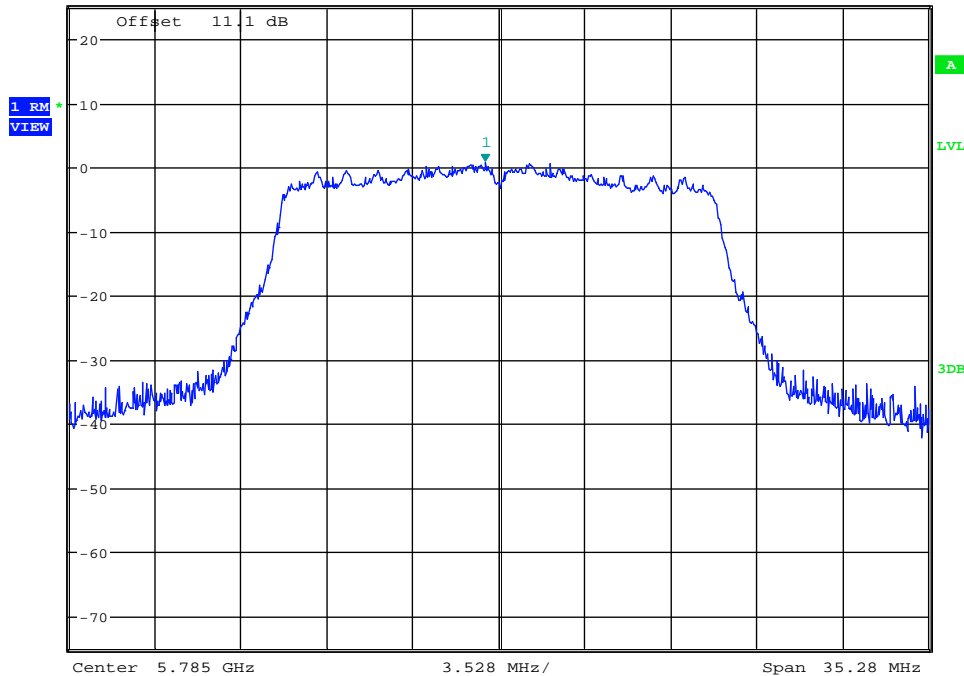

Date: 29.DEC.2017 20:51:16

Maximum Power Spectral Density\_TNVN\_11AC20SISO\_5785\_Ant2



Ref 25 dBm \* Att 20 dB \* RBW 500 kHz Marker 1 [T1 ] 0.93 dBm  
\* VBW 2 MHz SWT 20 ms 5.784469600 GHz

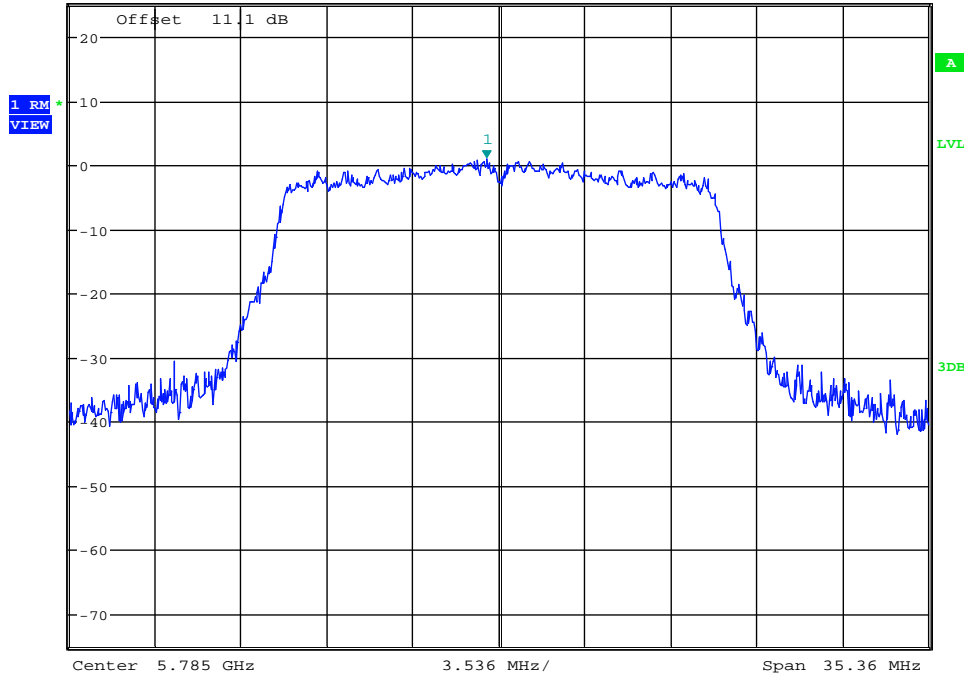

Date: 3.JAN.2018 16:32:36

Maximum Power Spectral Density\_TNVN\_11AC20SISO\_5825\_Ant1



Ref 25 dBm \* Att 20 dB \* RBW 500 kHz Marker 1 [T1 ] 0.17 dBm  
\* VBW 2 MHz SWT 20 ms 5.824646400 GHz

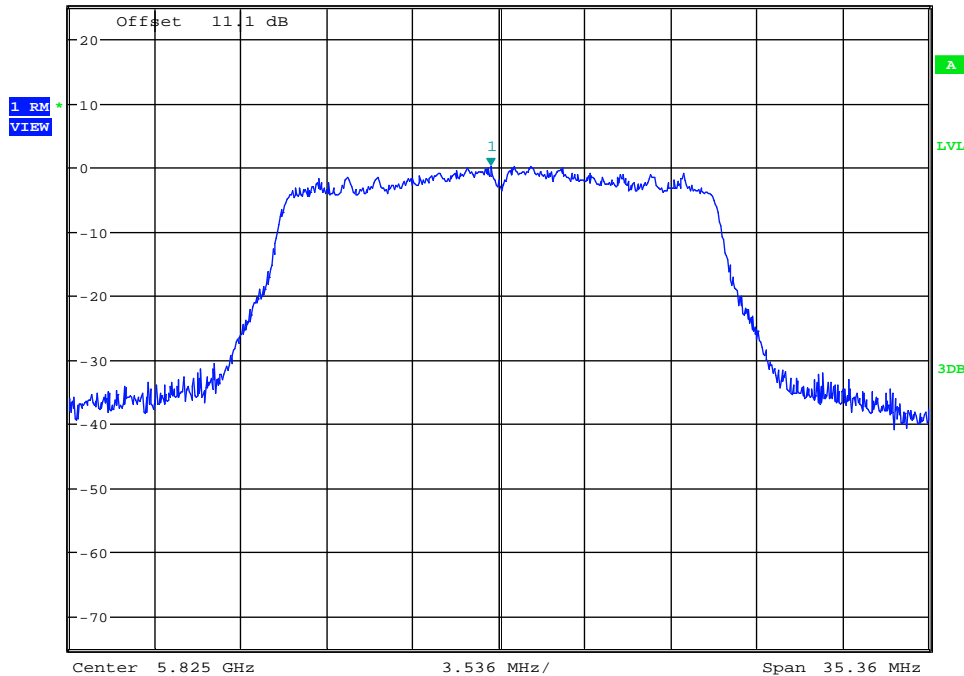

Date: 29.DEC.2017 20:55:15

Maximum Power Spectral Density\_TNVN\_11AC20SISO\_5825\_Ant2



Ref 25 dBm \* Att 20 dB \* RBW 500 kHz Marker 1 [T1 ] 0.63 dBm  
\* VBW 2 MHz 5.824432960 GHz  
SWT 20 ms

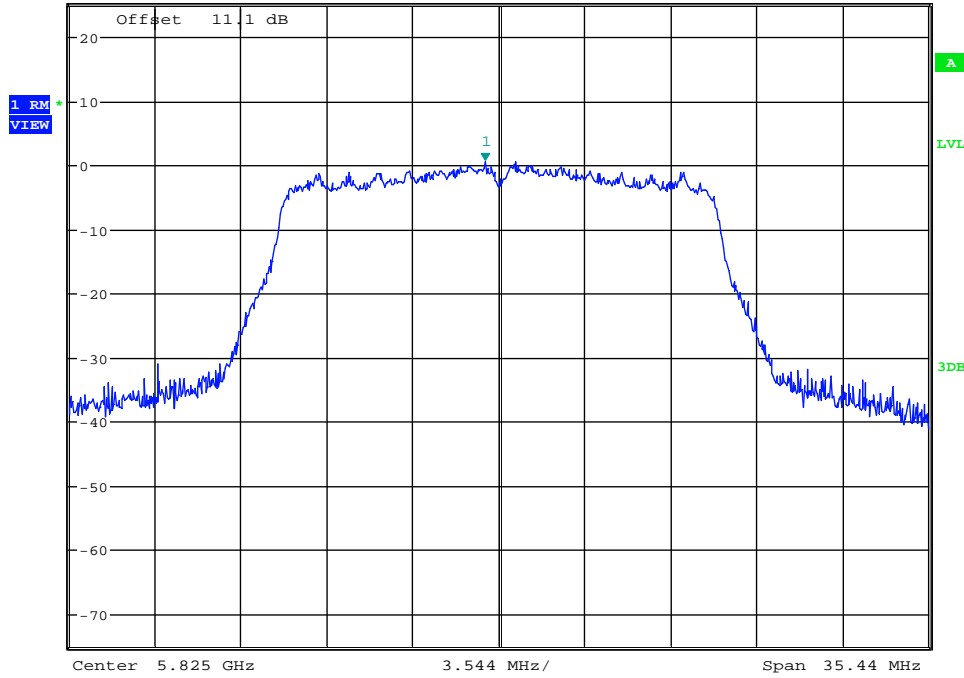

Date: 3.JAN.2018 16:36:50

Maximum Power Spectral Density\_TNVN\_11AC40SISO\_5190\_Ant1



Ref 25 dBm \* Att 20 dB \* RBW 1 MHz Marker 1 [T1 ] -2.86 dBm  
\* VBW 3 MHz 5.191202400 GHz  
SWT 20 ms

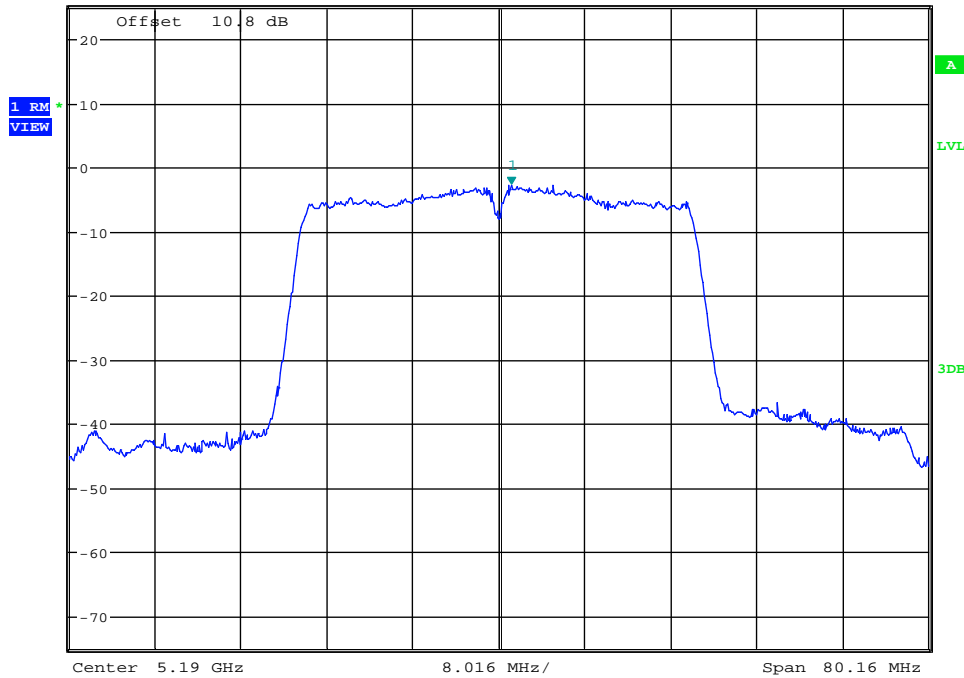

Date: 2.JAN.2018 13:41:06

Maximum Power Spectral Density\_TNVN\_11AC40SISO\_5190\_Ant2

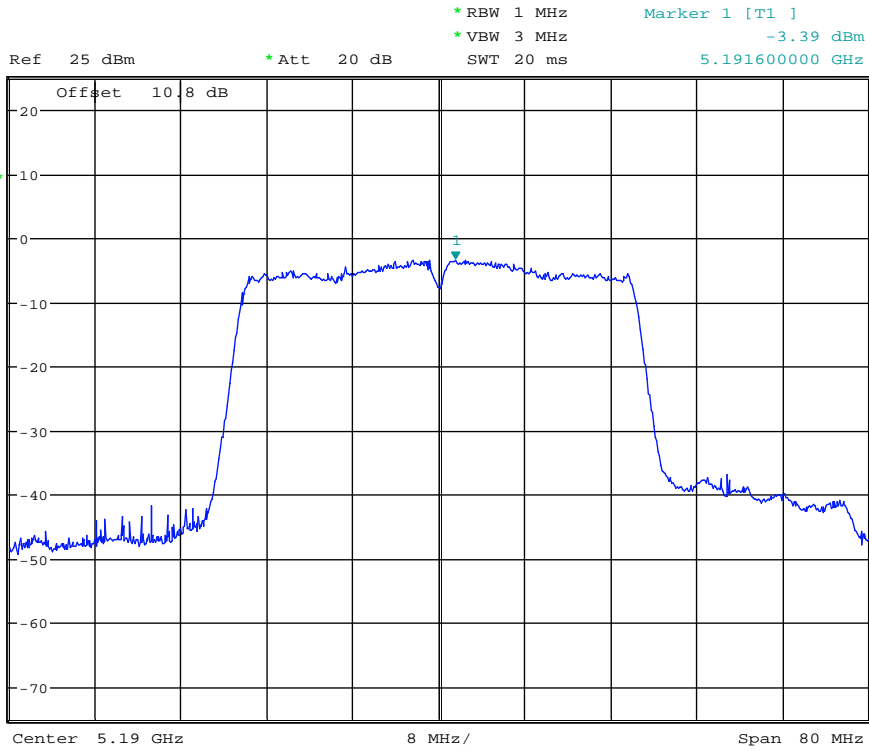

Date: 3.JAN.2018 16:41:23

Maximum Power Spectral Density\_TNVN\_11AC40SISO\_5230\_Ant1

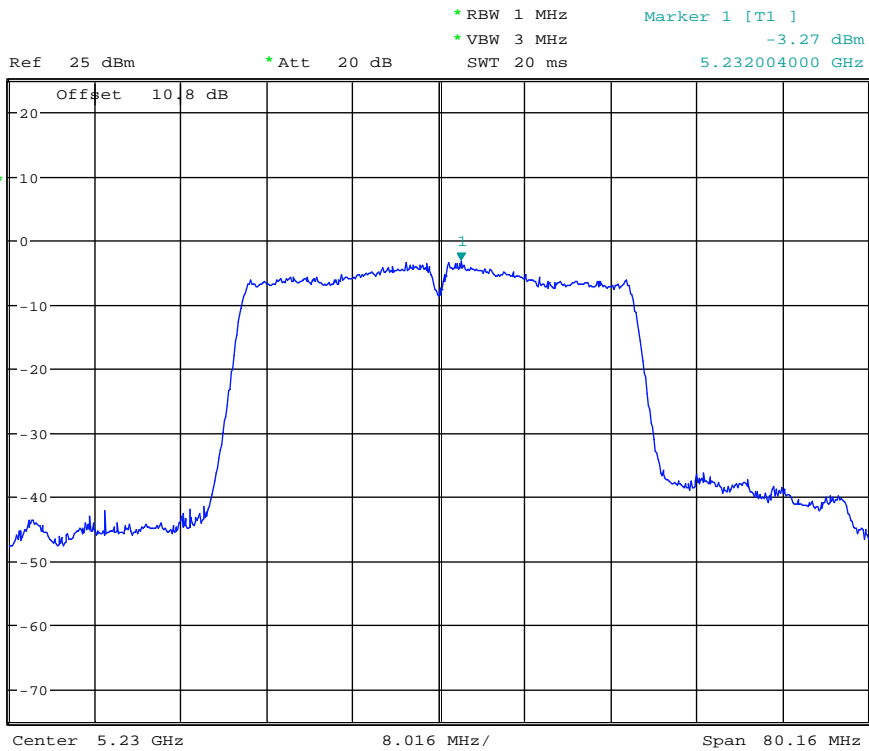

Date: 2.JAN.2018 13:46:41

Maximum Power Spectral Density\_TNVN\_11AC40SISO\_5230\_Ant2

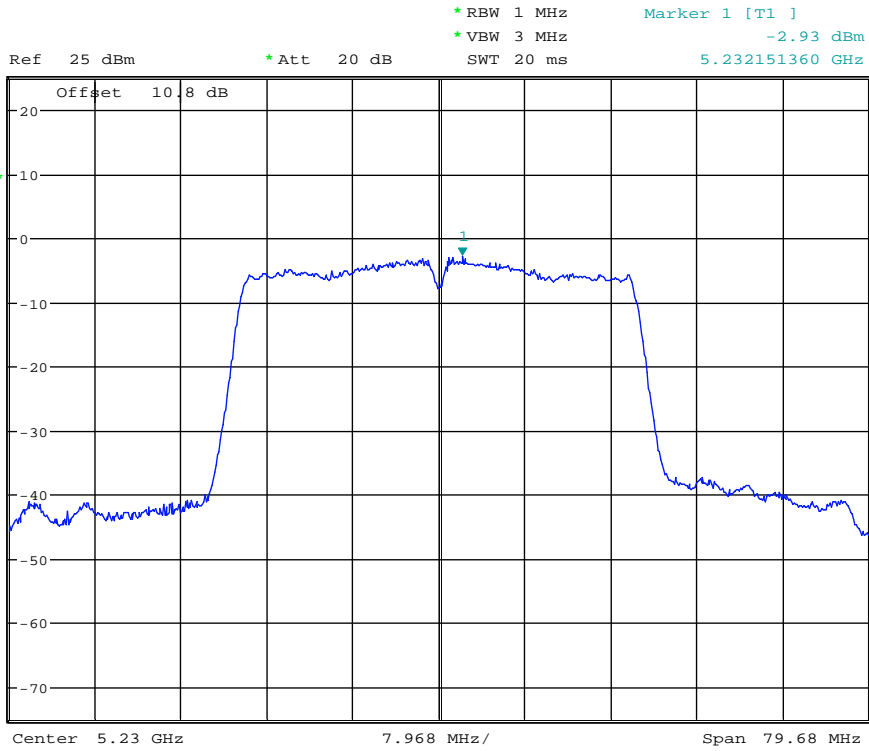

Date: 3.JAN.2018 16:45:57

Maximum Power Spectral Density\_TNVN\_11AC40SISO\_5270\_Ant1

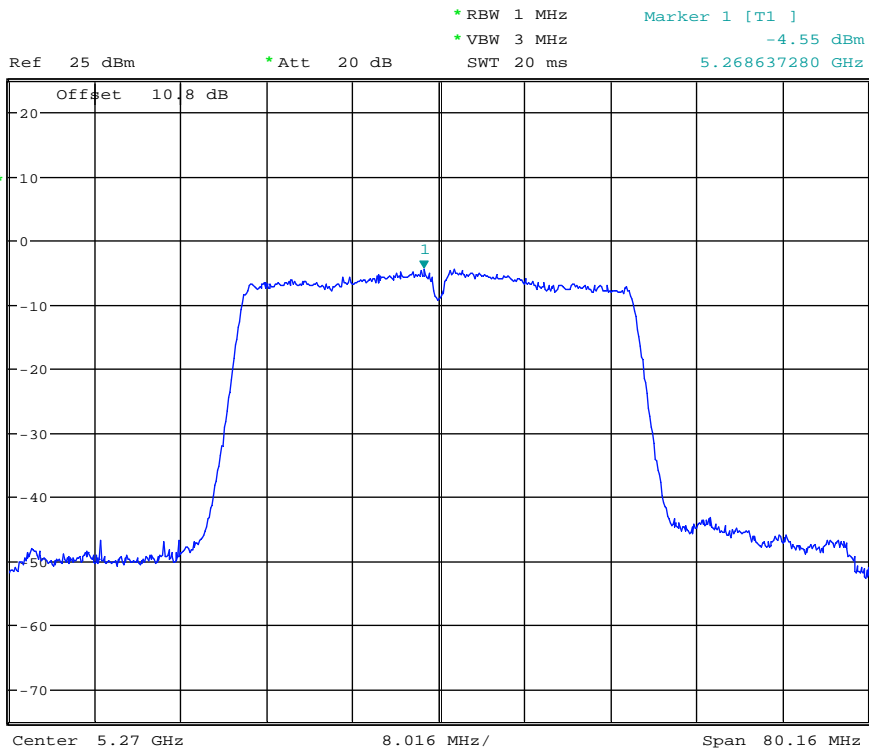

Date: 2.JAN.2018 13:51:16

Maximum Power Spectral Density\_TNVN\_11AC40SISO\_5270\_Ant2



Ref 25 dBm \* Att 20 dB \* RBW 1 MHz \* VBW 3 MHz \* Marker 1 [T1 ] -4.04 dBm  
SWT 20 ms 5.271931520 GHz

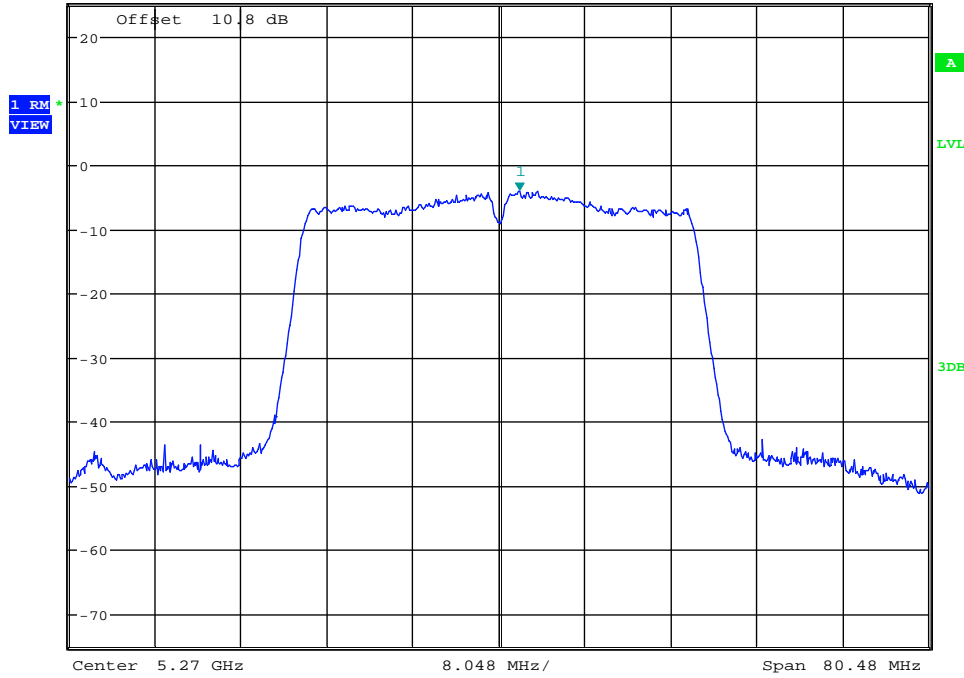

Date: 3.JAN.2018 16:50:51

Maximum Power Spectral Density\_TNVN\_11AC40SISO\_5310\_Ant1



Ref 25 dBm \* Att 20 dB \* RBW 1 MHz \* VBW 3 MHz \* Marker 1 [T1 ] -3.51 dBm  
SWT 20 ms 5.311851040 GHz

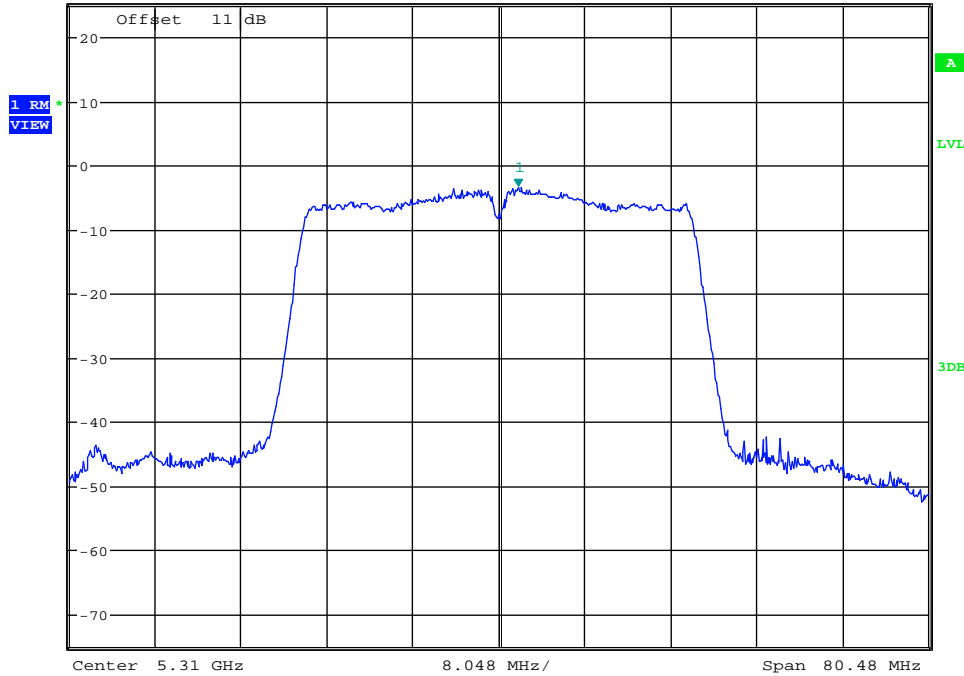

Date: 2.JAN.2018 13:56:20

Maximum Power Spectral Density\_TNVN\_11AC40SISO\_5310\_Ant2

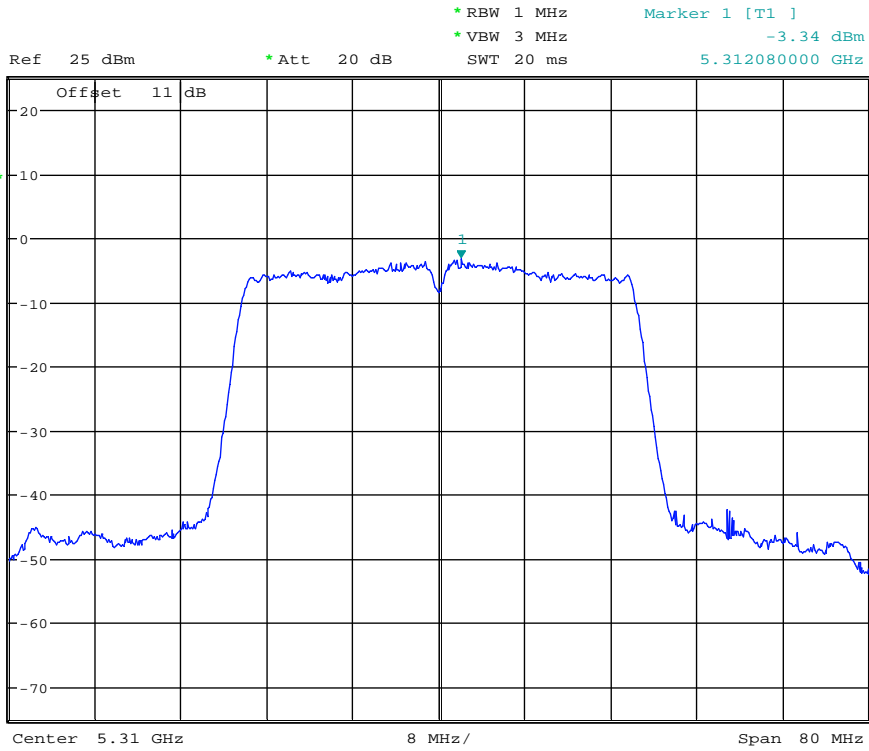

Date: 3.JAN.2018 16:55:57

Maximum Power Spectral Density\_TNVN\_11AC40SISO\_5510\_Ant1

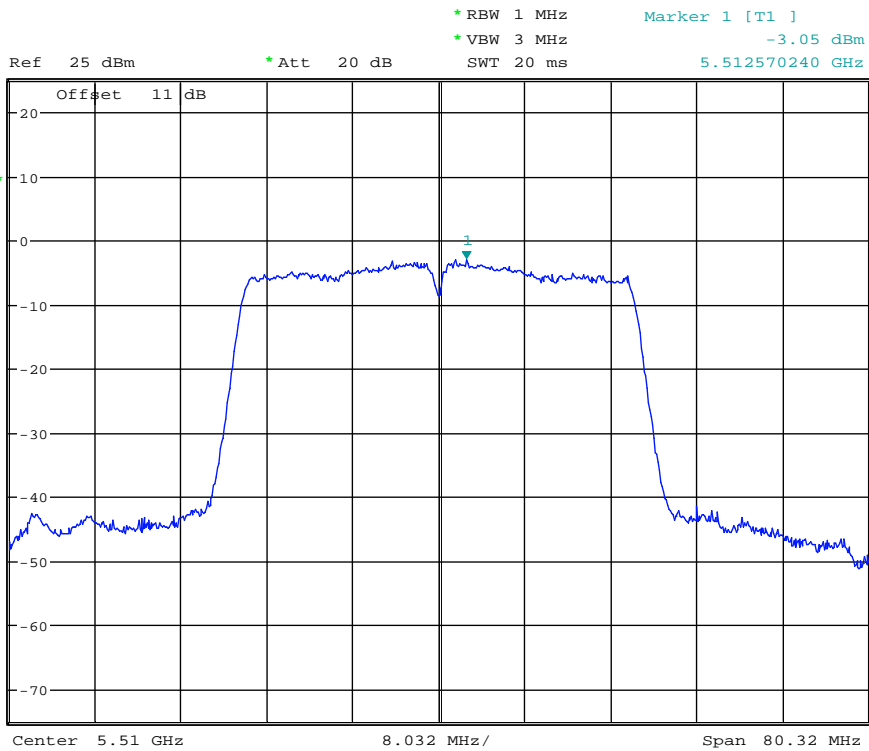

Date: 2.JAN.2018 14:01:20

Maximum Power Spectral Density\_TNVN\_11AC40SISO\_5510\_Ant2



Ref 25 dBm \* Att 20 dB \* RBW 1 MHz \* VBW 3 MHz \* SWT 20 ms Marker 1 [T1 ] -3.82 dBm 5.512395200 GHz

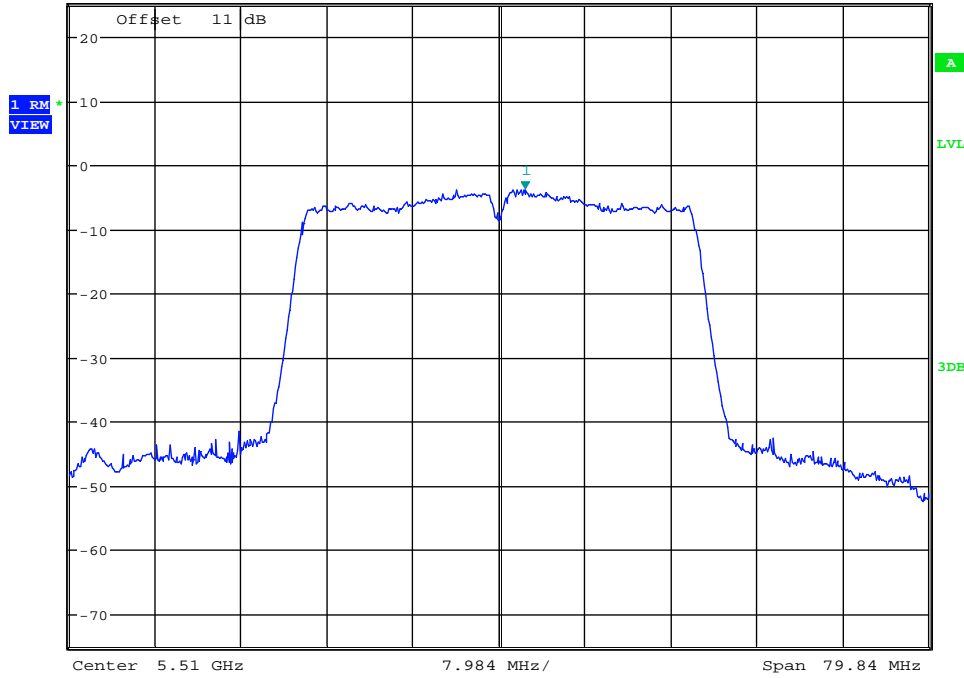

Date: 3.JAN.2018 17:08:20

Maximum Power Spectral Density\_TNVN\_11AC40SISO\_5550\_Ant1



Ref 25 dBm \* Att 20 dB \* RBW 1 MHz \* VBW 3 MHz \* SWT 20 ms Marker 1 [T1 ] -4.59 dBm 5.551282560 GHz

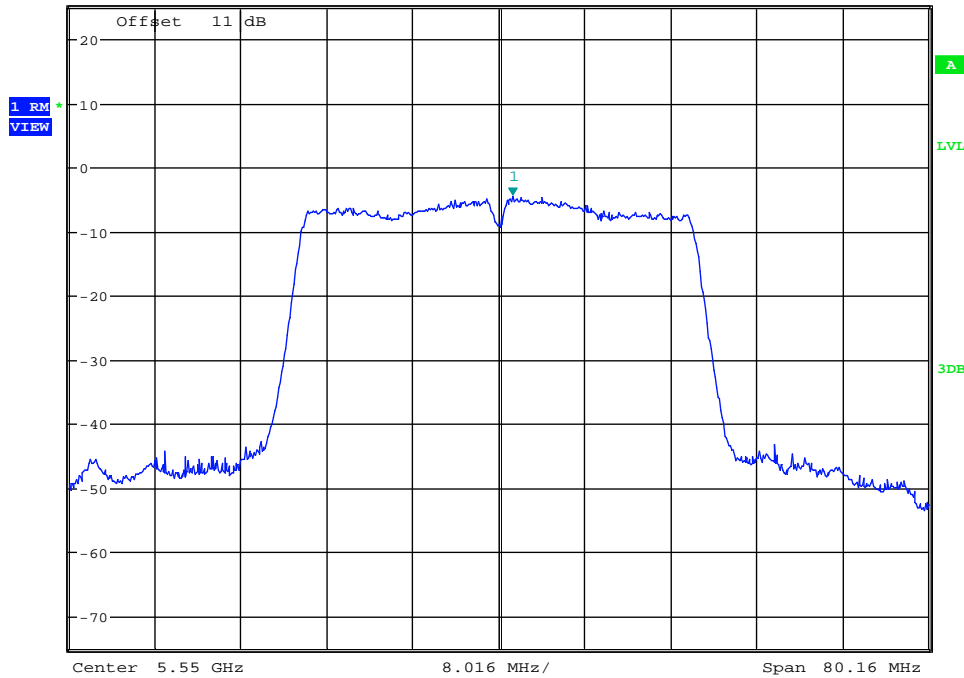

Date: 2.JAN.2018 14:06:13

Maximum Power Spectral Density\_TNVN\_11AC40SISO\_5550\_Ant2



Ref 25 dBm \* Att 20 dB \* RBW 1 MHz Marker 1 [T1 ]  
\* VBW 3 MHz -4.49 dBm  
SWT 20 ms 5.548384000 GHz

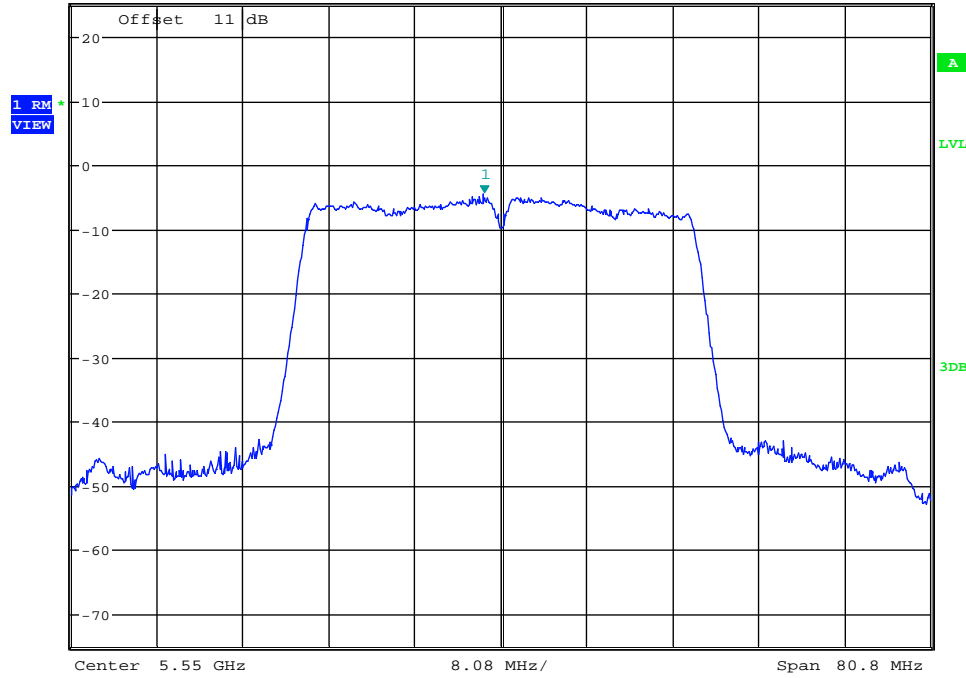

Date: 3.JAN.2018 17:13:01

### Maximum Power Spectral Density\_TNVN\_11AC40SISO\_5670\_Ant1



Ref 25 dBm \* Att 20 dB \* RBW 1 MHz Marker 1 [T1 ]  
\* VBW 3 MHz -4.02 dBm  
SWT 20 ms 5.671683360 GHz

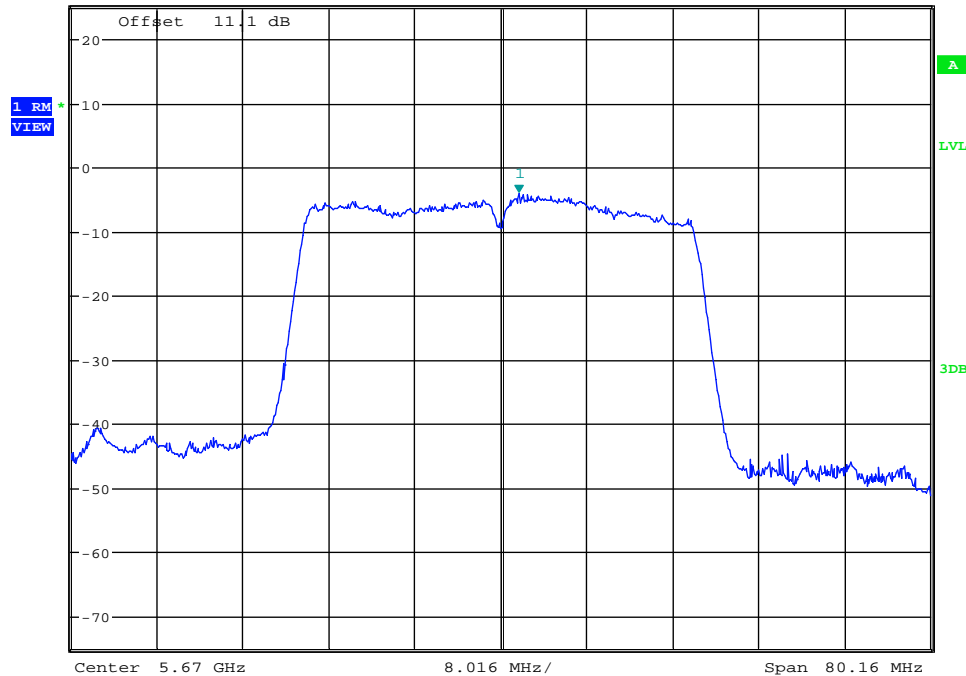

Date: 2.JAN.2018 14:10:28

### Maximum Power Spectral Density\_TNVN\_11AC40SISO\_5670\_Ant2



Ref 25 dBm \* Att 20 dB \* RBW 1 MHz \* VBW 3 MHz \* Marker 1 [T1 ] -4.07 dBm  
SWT 20 ms 5.671040000 GHz

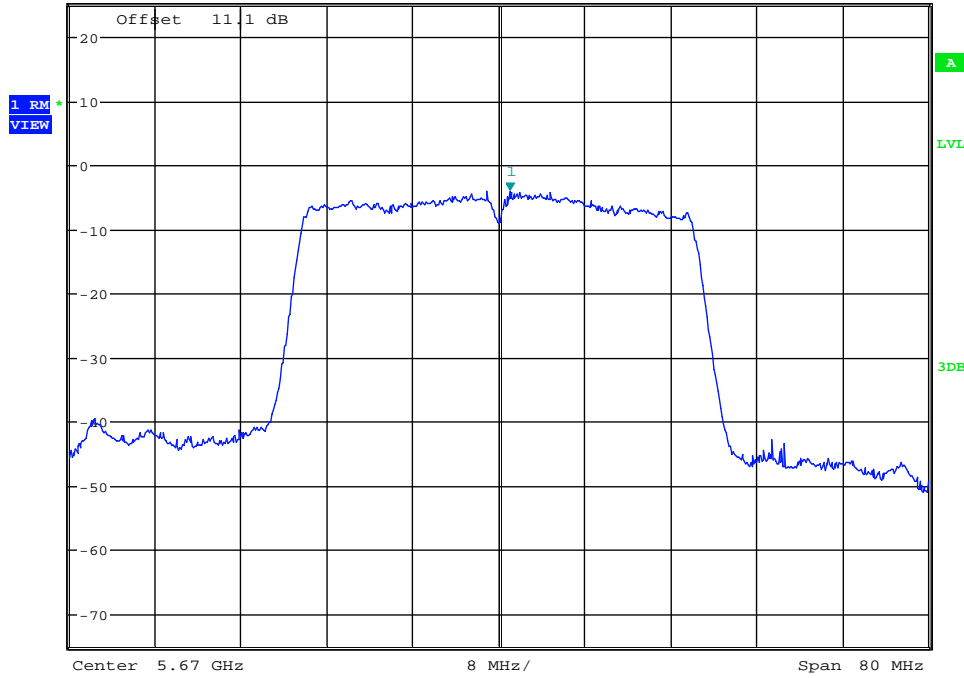

Date: 3.JAN.2018 17:17:29

Maximum Power Spectral Density\_TNVN\_11AC40SISO\_5755\_Ant1



Ref 25 dBm \* Att 20 dB \* RBW 500 kHz \* VBW 2 MHz \* Marker 1 [T1 ] -4.61 dBm  
SWT 20 ms 5.758824480 GHz

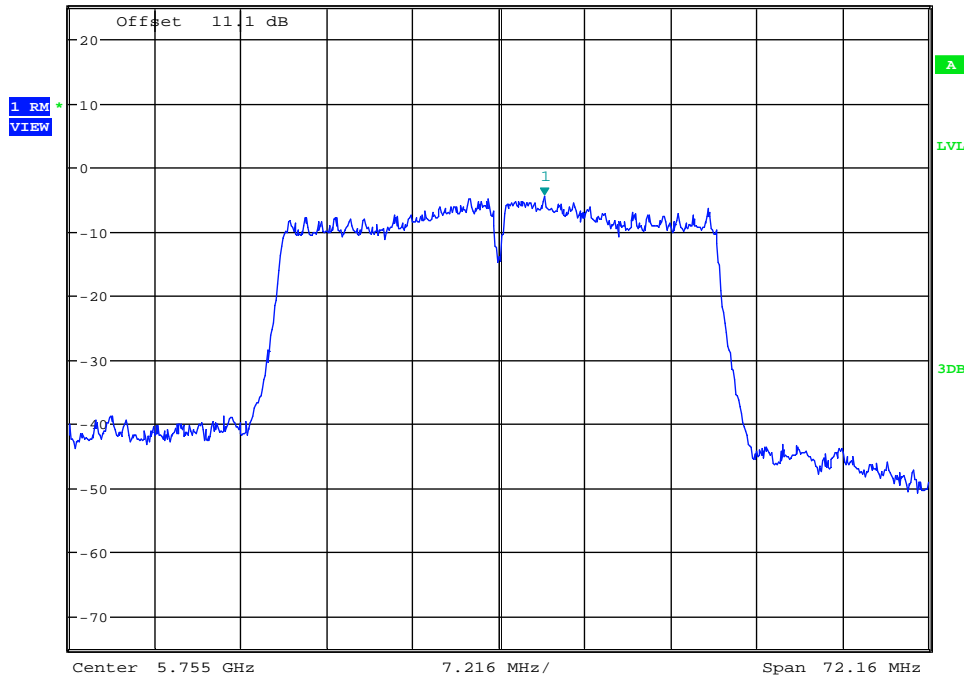

Date: 2.JAN.2018 14:16:49

Maximum Power Spectral Density\_TNVN\_11AC40SISO\_5755\_Ant2



Ref 25 dBm \* Att 20 dB \* RBW 500 kHz \* VBW 2 MHz \* Marker 1 [T1 ] -5.13 dBm  
SWT 20 ms 5.760337760 GHz

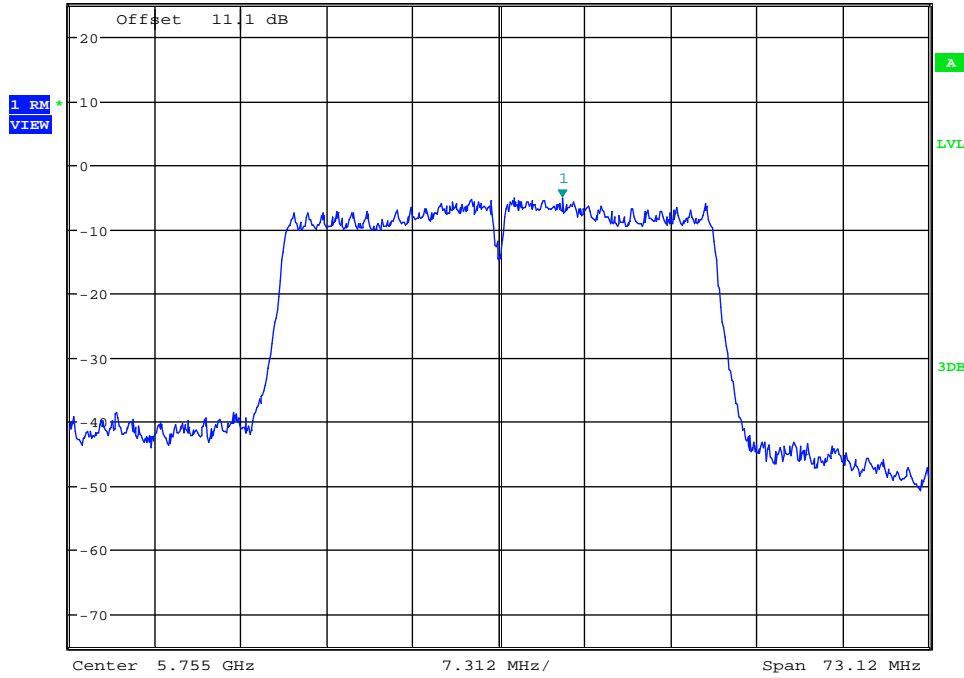

Date: 3.JAN.2018 17:22:46

Maximum Power Spectral Density\_TNVN\_11AC40SISO\_5795\_Ant1



Ref 25 dBm \* Att 20 dB \* RBW 500 kHz \* VBW 2 MHz \* Marker 1 [T1 ] -5.21 dBm  
SWT 20 ms 5.797115840 GHz

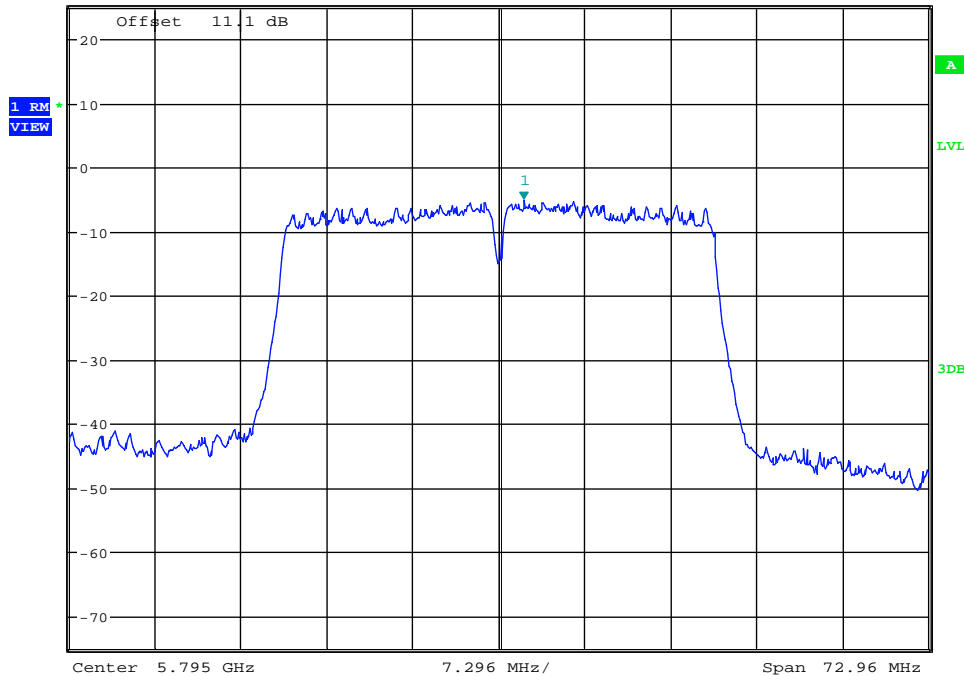

Date: 2.JAN.2018 14:26:01

Maximum Power Spectral Density\_TNVN\_11AC40SISO\_5795\_Ant2



Ref 25 dBm \* Att 20 dB \* RBW 500 kHz Marker 1 [T1 ] -5.13 dBm  
\* VBW 2 MHz 5.797486080 GHz  
SWT 20 ms

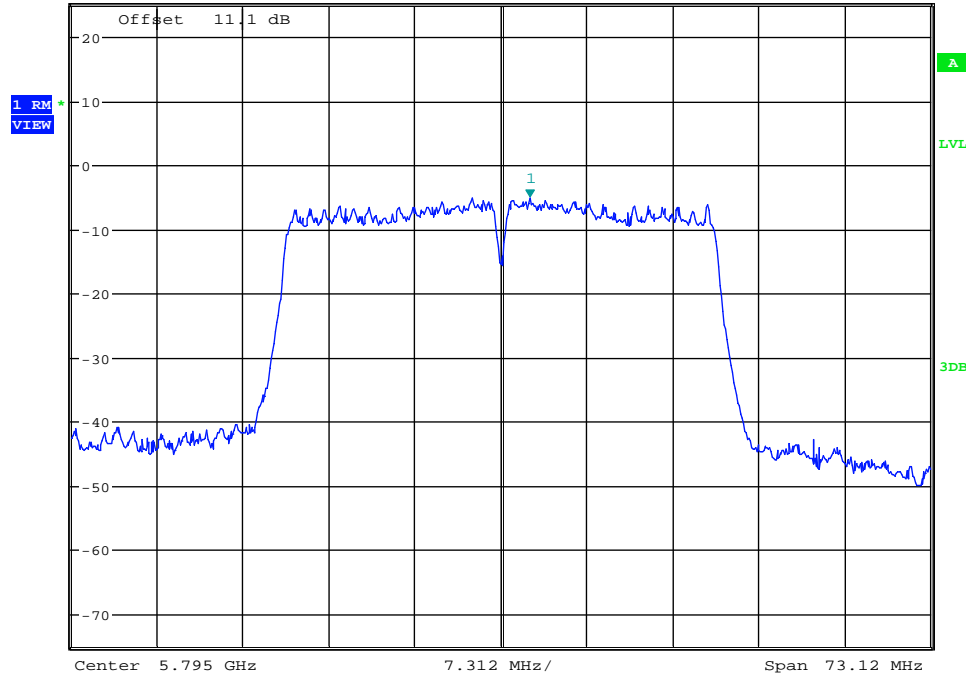

Date: 3.JAN.2018 17:27:46

Maximum Power Spectral Density\_TNVN\_11AC80SISO\_5210\_Ant1



Ref 25 dBm \* Att 20 dB \* RBW 1 MHz Marker 1 [T1 ] -6.87 dBm  
\* VBW 3 MHz 5.208049280 GHz  
SWT 20 ms

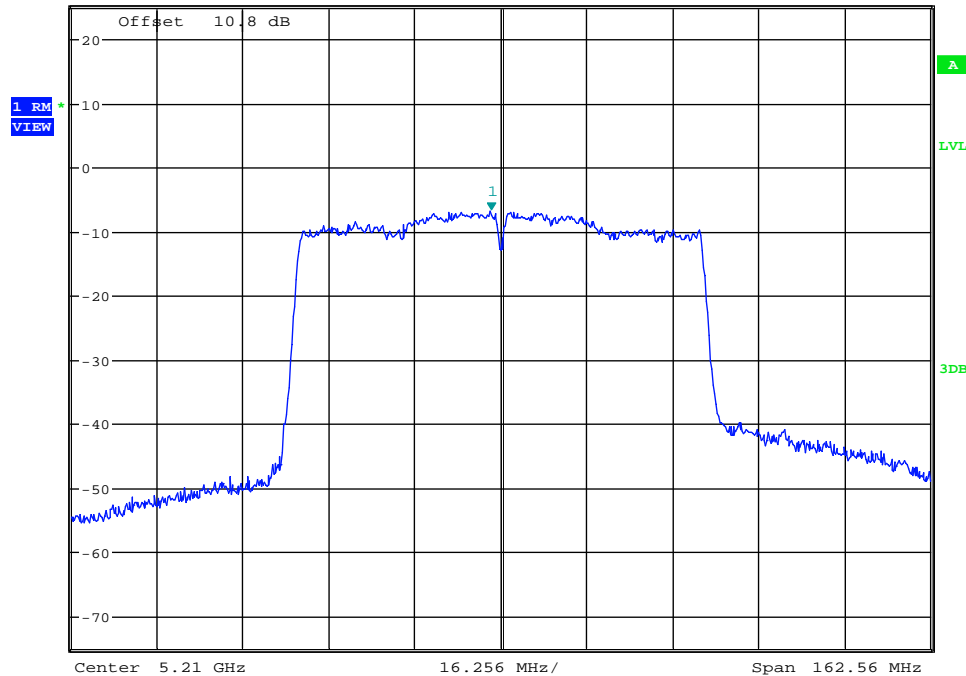

Date: 2.JAN.2018 14:31:20

Maximum Power Spectral Density\_TNVN\_11AC80SISO\_5210\_Ant2



Ref 25 dBm \* Att 20 dB \* RBW 1 MHz Marker 1 [T1 ]  
\* VBW 3 MHz -6.03 dBm  
SWT 20 ms 5.208208320 GHz

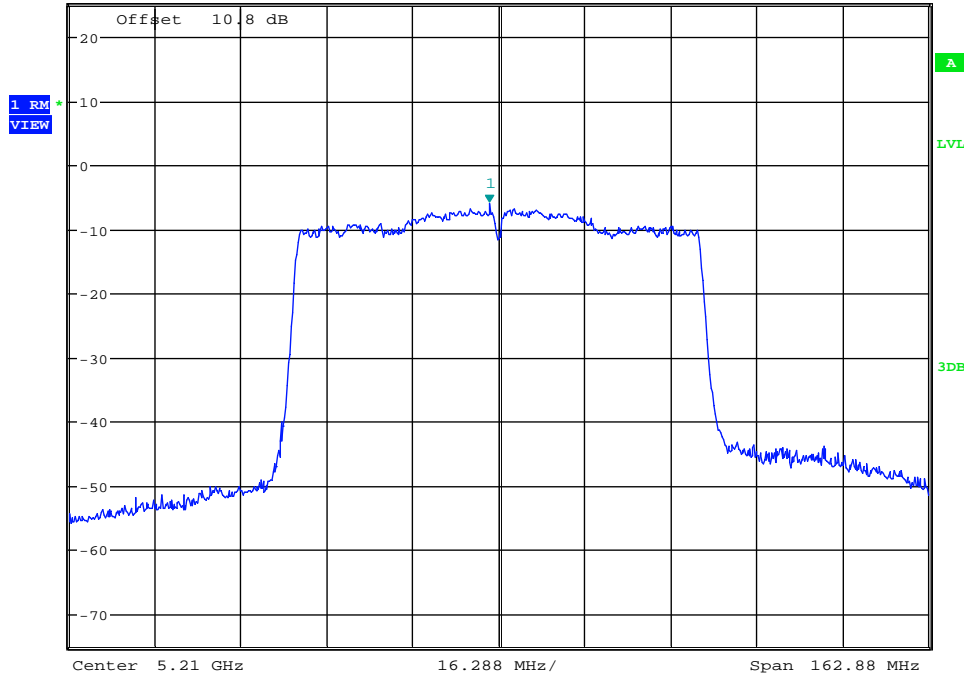

Date: 3.JAN.2018 17:33:51

Maximum Power Spectral Density\_TNVN\_11AC80SISO\_5290\_Ant1



Ref 25 dBm \* Att 20 dB \* RBW 1 MHz Marker 1 [T1 ]  
\* VBW 3 MHz -7.16 dBm  
SWT 20 ms 5.284462080 GHz

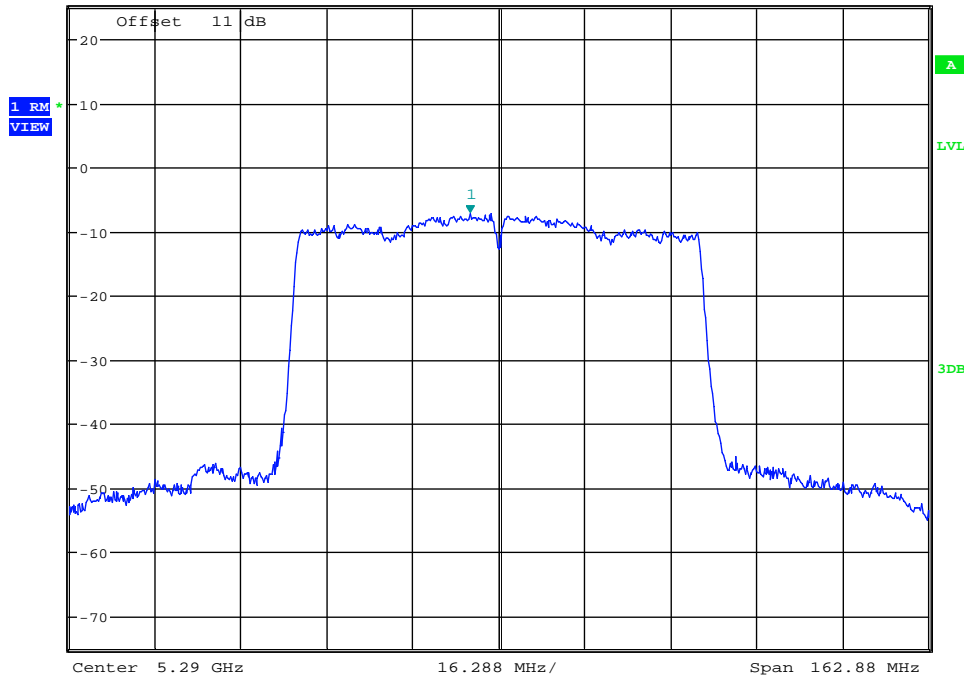

Date: 2.JAN.2018 14:37:28

Maximum Power Spectral Density\_TNVN\_11AC80SISO\_5290\_Ant2



Ref 25 dBm \* Att 20 dB \* RBW 1 MHz \* VBW 3 MHz \* Marker 1 [T1 ] -7.12 dBm  
SWT 20 ms 5.291802240 GHz

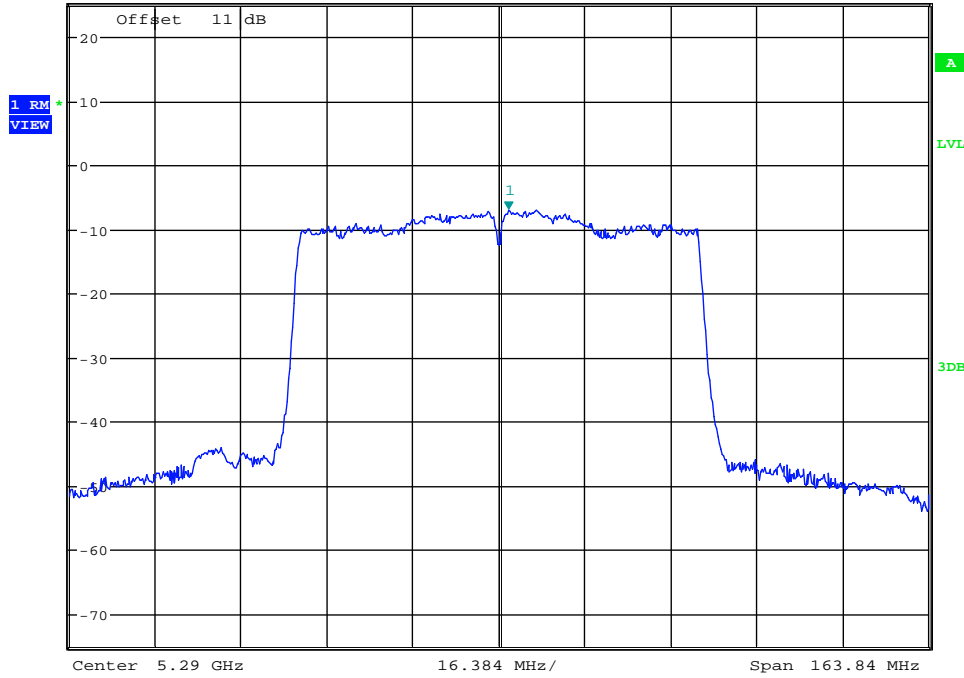

Date: 3.JAN.2018 17:39:59

Maximum Power Spectral Density\_TNVN\_11AC80SISO\_5530\_Ant1



Ref 25 dBm \* Att 20 dB \* RBW 1 MHz \* VBW 3 MHz \* Marker 1 [T1 ] -6.57 dBm  
SWT 20 ms 5.527710720 GHz

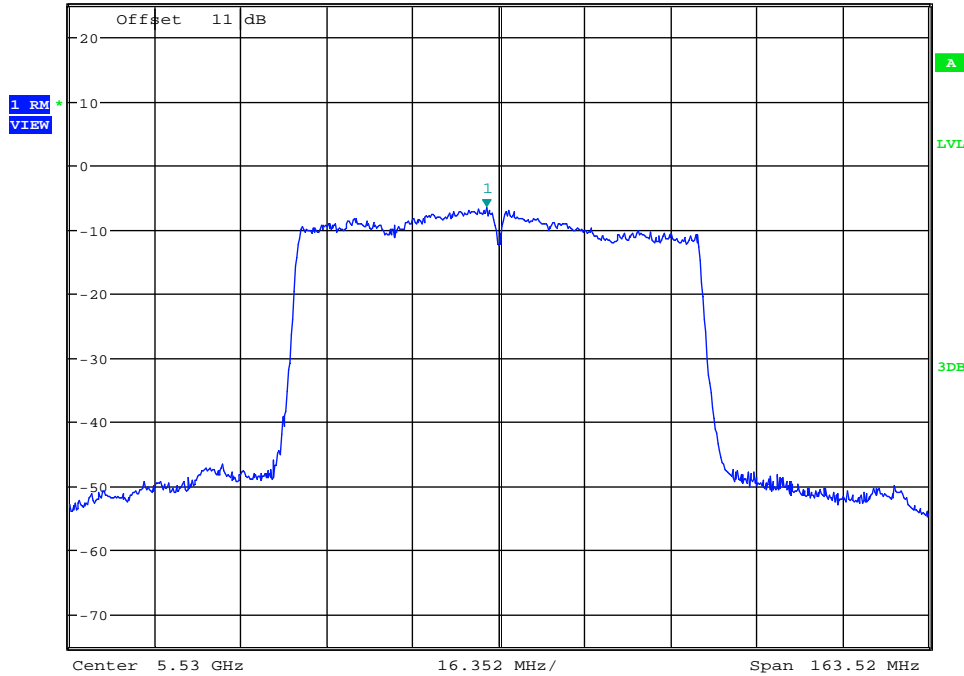

Date: 2.JAN.2018 14:44:31

Maximum Power Spectral Density\_TNVN\_11AC80SISO\_5530\_Ant2

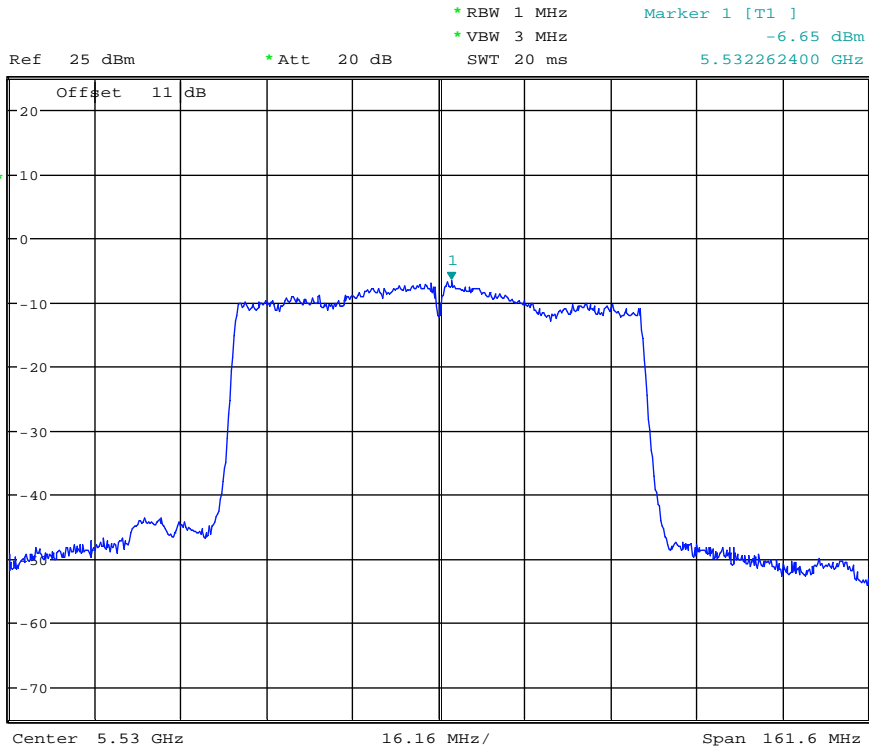

Date: 3.JAN.2018 17:48:09

Maximum Power Spectral Density\_TNVN\_11AC80SISO\_5775\_Ant1

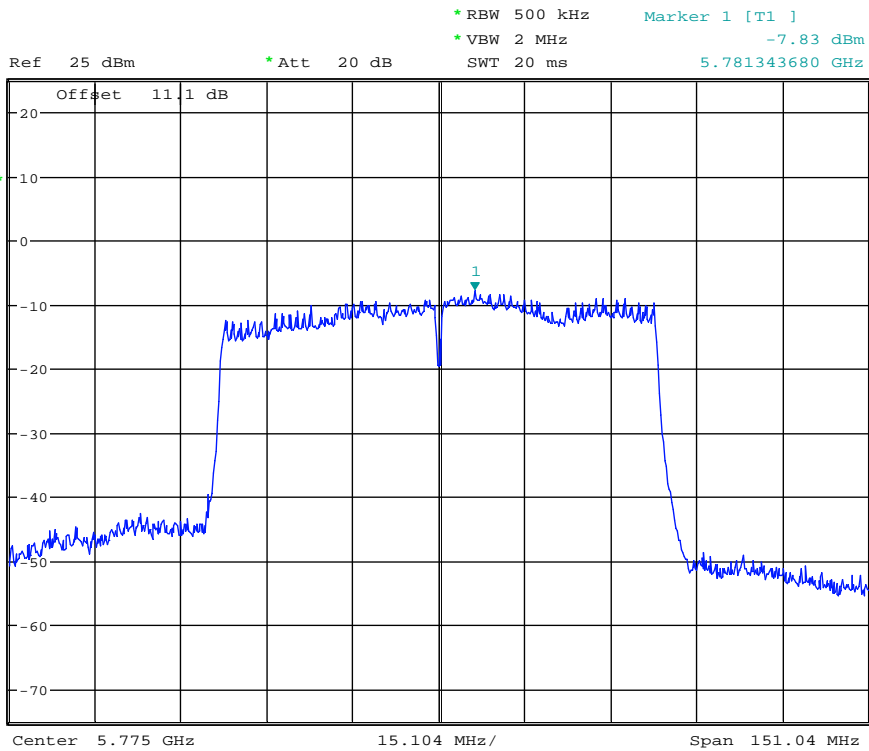

Date: 2.JAN.2018 14:50:44

Maximum Power Spectral Density\_TNVN\_11AC80SISO\_5775\_Ant2

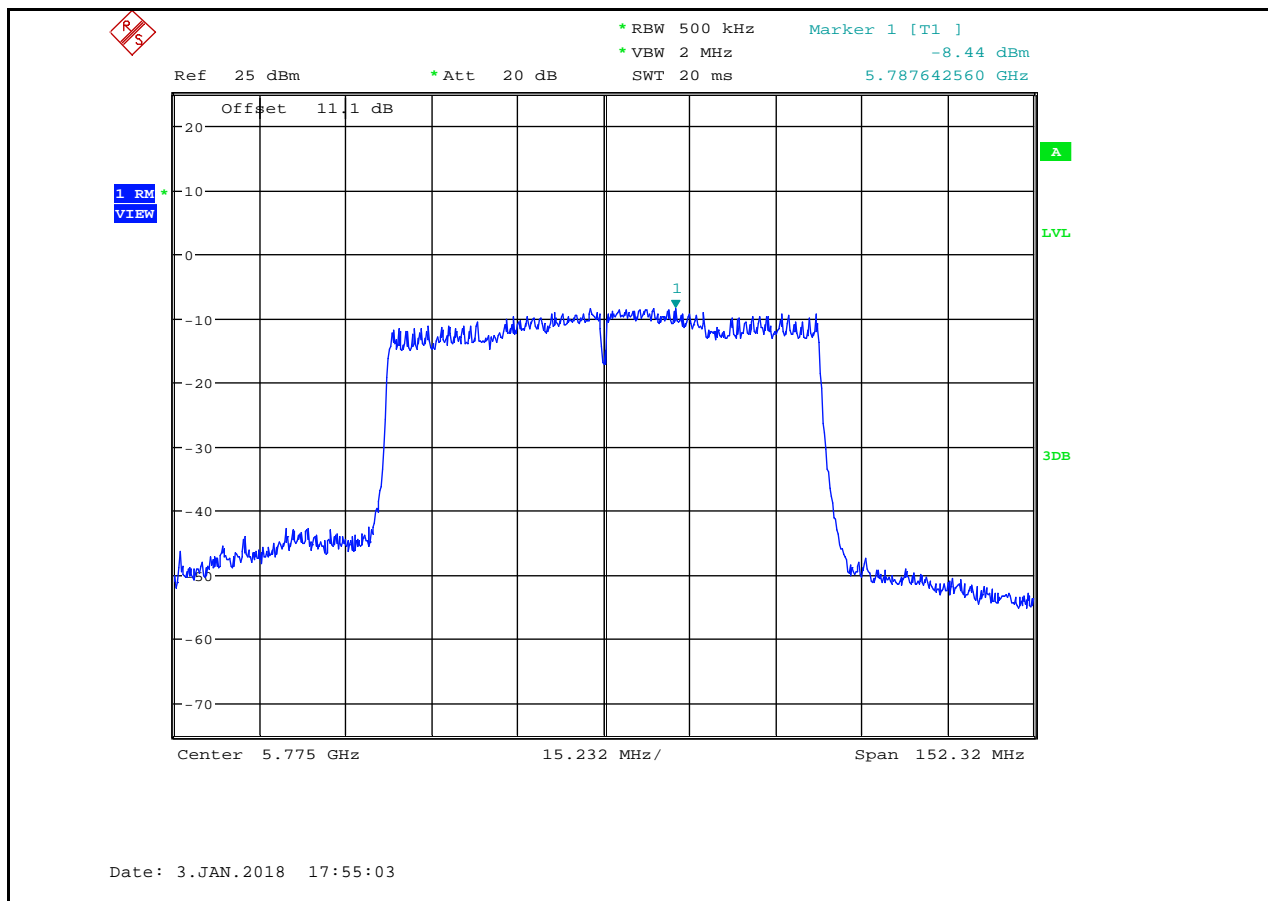

## 8. Frequency Stability Measurement

### 8.1. Limit of Frequency Stability

Manufacturers of U-NII devices are responsible for ensuring frequency stability such that an emission is maintained within the band of operation under all conditions of normal operation as specified in the user's manual.

### 8.2. Measuring Instruments

The measuring equipment is listed in the section 4 of this test report.

### 8.3. Test Procedures

- (1) To ensure emission at the band edge is maintained within the authorized band, those values shall be measured by radiation emissions at upper and lower frequency points, and finally compensated by frequency deviation as procedures below.
- (2) The EUT was operated at the maximum output power, and connected to the spectrum analyzer, which is set to maximum hold function and peak detector. The peak value of the power envelope was measured and noted. The upper and lower frequency points were respectively measured relatively 10dB lower than the measured peak value.
- (3) The frequency deviation was calculated by adding the upper frequency point and the lower frequency point divided by two. Those detailed values of frequency deviation are provided in table below.



11A	5320	Ant1	TN	VH	5320.02	2.81955	20	PASS
11A	5320	Ant1	TN	VN	5320.03	5.63910	20	PASS
11A	5320	Ant1	TN	VL	5320.02	2.81955	20	PASS
11A	5320	Ant2	TN	VL	5320.03	5.63910	20	PASS
11A	5320	Ant2	TN	VH	5320.03	5.63910	20	PASS
11A	5320	Ant2	TN	VN	5320.02	2.81955	20	PASS
11A	5500	Ant1	TN	VN	5500.03	5.45455	20	PASS
11A	5500	Ant1	TN	VL	5500.02	2.72727	20	PASS
11A	5500	Ant1	TN	VH	5500.03	5.45455	20	PASS
11A	5500	Ant2	TN	VL	5500.03	5.45455	20	PASS
11A	5500	Ant2	TN	VH	5500.03	5.45455	20	PASS
11A	5500	Ant2	TN	VN	5500.02	2.72727	20	PASS
11A	5580	Ant1	TN	VN	5580.02	2.68817	20	PASS
11A	5580	Ant1	TN	VL	5580.03	5.37634	20	PASS
11A	5580	Ant1	TN	VH	5580.02	2.68817	20	PASS
11A	5580	Ant2	TN	VL	5579.99	-2.68817	20	PASS
11A	5580	Ant2	TN	VN	5579.99	-2.68817	20	PASS
11A	5580	Ant2	TN	VH	5580.00	0.00000	20	PASS
11A	5700	Ant1	TN	VH	5700.08	13.15790	20	PASS
11A	5700	Ant1	TN	VN	5700.06	10.52632	20	PASS
11A	5700	Ant1	TN	VL	5700.08	13.15790	20	PASS
11A	5700	Ant2	TN	VL	5700.08	13.15790	20	PASS
11A	5700	Ant2	TN	VN	5700.09	15.78947	20	PASS
11A	5700	Ant2	TN	VH	5700.08	13.15790	20	PASS
11A	5745	Ant1	TN	VL	5745.05	7.83290	20	PASS
11A	5745	Ant1	TN	VH	5745.03	5.22193	20	PASS
11A	5745	Ant1	TN	VN	5745.06	10.44386	20	PASS
11A	5745	Ant2	TN	VL	5745.08	13.05483	20	PASS
11A	5745	Ant2	TN	VH	5745.06	10.44386	20	PASS
11A	5745	Ant2	TN	VN	5745.08	13.05483	20	PASS
11A	5785	Ant1	TN	VH	5785.03	5.18583	20	PASS
11A	5785	Ant1	TN	VN	5785.03	5.18583	20	PASS
11A	5785	Ant1	TN	VL	5785.03	5.18583	20	PASS
11A	5785	Ant2	TN	VL	5785.02	2.59291	20	PASS
11A	5785	Ant2	TN	VH	5785.02	2.59291	20	PASS
11A	5785	Ant2	TN	VN	5785.02	2.59291	20	PASS
11A	5825	Ant1	TN	VN	5825.03	5.15022	20	PASS
11A	5825	Ant1	TN	VL	5825.03	5.15022	20	PASS
11A	5825	Ant1	TN	VH	5825.03	5.15022	20	PASS
11A	5825	Ant2	TN	VH	5825.02	2.57511	20	PASS

11A	5825	Ant2	TN	VN	5825.02	2.57511	20	PASS
11A	5825	Ant2	TN	VL	5825.00	0.00000	20	PASS
11N20SISO	5180	Ant1	TN	VH	5179.97	-5.79151	20	PASS
11N20SISO	5180	Ant1	TN	VN	5179.97	-5.79151	20	PASS
11N20SISO	5180	Ant1	TN	VL	5179.99	-2.89575	20	PASS
11N20SISO	5180	Ant2	TN	VH	5180.00	0.00000	20	PASS
11N20SISO	5180	Ant2	TN	VL	5180.03	5.79151	20	PASS
11N20SISO	5180	Ant2	TN	VN	5180.06	11.58301	20	PASS
11N20SISO	5200	Ant1	TN	VN	5199.97	-5.76923	20	PASS
11N20SISO	5200	Ant1	TN	VL	5199.96	-8.65385	20	PASS
11N20SISO	5200	Ant1	TN	VH	5200.00	0.00000	20	PASS
11N20SISO	5200	Ant2	TN	VL	5200.02	2.88462	20	PASS
11N20SISO	5200	Ant2	TN	VN	5200.03	5.76923	20	PASS
11N20SISO	5200	Ant2	TN	VH	5200.03	5.76923	20	PASS
11N20SISO	5240	Ant1	TN	VN	5240.02	2.86260	20	PASS
11N20SISO	5240	Ant1	TN	VH	5240.00	0.00000	20	PASS
11N20SISO	5240	Ant1	TN	VL	5239.97	-5.72519	20	PASS
11N20SISO	5240	Ant2	TN	VH	5240.02	2.86260	20	PASS
11N20SISO	5240	Ant2	TN	VL	5240.03	5.72519	20	PASS
11N20SISO	5240	Ant2	TN	VN	5240.02	2.86260	20	PASS
11N20SISO	5260	Ant1	TN	VN	5260.02	2.85171	20	PASS
11N20SISO	5260	Ant1	TN	VL	5260.03	5.70342	20	PASS
11N20SISO	5260	Ant1	TN	VH	5260.00	0.00000	20	PASS
11N20SISO	5260	Ant2	TN	VL	5260.03	5.70342	20	PASS
11N20SISO	5260	Ant2	TN	VH	5259.99	-2.85171	20	PASS
11N20SISO	5260	Ant2	TN	VN	5260.02	2.85171	20	PASS
11N20SISO	5280	Ant1	TN	VN	5280.05	8.52273	20	PASS
11N20SISO	5280	Ant1	TN	VH	5280.03	5.68182	20	PASS
11N20SISO	5280	Ant1	TN	VL	5280.03	5.68182	20	PASS
11N20SISO	5280	Ant2	TN	VL	5280.02	2.84091	20	PASS
11N20SISO	5280	Ant2	TN	VN	5280.03	5.68182	20	PASS
11N20SISO	5280	Ant2	TN	VH	5280.06	11.36364	20	PASS
11N20SISO	5320	Ant1	TN	VL	5320.06	11.27820	20	PASS
11N20SISO	5320	Ant1	TN	VN	5320.05	8.45865	20	PASS
11N20SISO	5320	Ant1	TN	VH	5320.03	5.63910	20	PASS
11N20SISO	5320	Ant2	TN	VH	5320.00	0.00000	20	PASS
11N20SISO	5320	Ant2	TN	VL	5320.05	8.45865	20	PASS
11N20SISO	5320	Ant2	TN	VN	5320.00	0.00000	20	PASS
11N20SISO	5500	Ant1	TN	VL	5500.02	2.72727	20	PASS
11N20SISO	5500	Ant1	TN	VN	5500.05	8.18182	20	PASS

11N20SISO	5500	Ant1	TN	VH	5500.02	2.72727	20	PASS
11N20SISO	5500	Ant2	TN	VL	5500.00	0.00000	20	PASS
11N20SISO	5500	Ant2	TN	VH	5500.02	2.72727	20	PASS
11N20SISO	5500	Ant2	TN	VN	5500.02	2.72727	20	PASS
11N20SISO	5580	Ant1	TN	VL	5580.00	0.00000	20	PASS
11N20SISO	5580	Ant1	TN	VN	5580.02	2.68817	20	PASS
11N20SISO	5580	Ant1	TN	VH	5580.03	5.37634	20	PASS
11N20SISO	5580	Ant2	TN	VH	5579.99	-2.68817	20	PASS
11N20SISO	5580	Ant2	TN	VN	5579.97	-5.37634	20	PASS
11N20SISO	5580	Ant2	TN	VL	5580.02	2.68817	20	PASS
11N20SISO	5700	Ant1	TN	VH	5700.11	18.42105	20	PASS
11N20SISO	5700	Ant1	TN	VN	5700.09	15.78947	20	PASS
11N20SISO	5700	Ant1	TN	VL	5700.08	13.15790	20	PASS
11N20SISO	5700	Ant2	TN	VL	5700.06	10.52632	20	PASS
11N20SISO	5700	Ant2	TN	VN	5700.09	15.78947	20	PASS
11N20SISO	5700	Ant2	TN	VH	5700.08	13.15790	20	PASS
11N20SISO	5745	Ant1	TN	VH	5745.08	13.05483	20	PASS
11N20SISO	5745	Ant1	TN	VN	5745.05	7.83290	20	PASS
11N20SISO	5745	Ant1	TN	VL	5745.08	13.05483	20	PASS
11N20SISO	5745	Ant2	TN	VH	5745.06	10.44386	20	PASS
11N20SISO	5745	Ant2	TN	VN	5745.06	10.44386	20	PASS
11N20SISO	5745	Ant2	TN	VL	5745.08	13.05483	20	PASS
11N20SISO	5785	Ant1	TN	VN	5785.00	0.00000	20	PASS
11N20SISO	5785	Ant1	TN	VL	5785.03	5.18583	20	PASS
11N20SISO	5785	Ant1	TN	VH	5785.05	7.77874	20	PASS
11N20SISO	5785	Ant2	TN	VH	5785.03	5.18583	20	PASS
11N20SISO	5785	Ant2	TN	VN	5784.99	-2.59291	20	PASS
11N20SISO	5785	Ant2	TN	VL	5784.99	-2.59291	20	PASS
11N20SISO	5825	Ant1	TN	VN	5825.05	7.72532	20	PASS
11N20SISO	5825	Ant1	TN	VL	5825.08	12.87554	20	PASS
11N20SISO	5825	Ant1	TN	VH	5825.06	10.30043	20	PASS
11N20SISO	5825	Ant2	TN	VL	5825.02	2.57511	20	PASS
11N20SISO	5825	Ant2	TN	VN	5825.00	0.00000	20	PASS
11N20SISO	5825	Ant2	TN	VH	5825.00	0.00000	20	PASS
11N40SISO	5190	Ant1	TN	VN	5190.03	5.78035	20	PASS
11N40SISO	5190	Ant1	TN	VH	5190.03	5.78035	20	PASS
11N40SISO	5190	Ant1	TN	VL	5190.03	5.78035	20	PASS
11N40SISO	5190	Ant2	TN	VL	5190.03	5.78035	20	PASS
11N40SISO	5190	Ant2	TN	VN	5189.97	-5.78035	20	PASS
11N40SISO	5190	Ant2	TN	VH	5190.03	5.78035	20	PASS

11N40SISO	5230	Ant1	TN	VL	5230.00	0.00000	20	PASS
11N40SISO	5230	Ant1	TN	VH	5230.03	5.73614	20	PASS
11N40SISO	5230	Ant1	TN	VN	5230.03	5.73614	20	PASS
11N40SISO	5230	Ant2	TN	VH	5230.00	0.00000	20	PASS
11N40SISO	5230	Ant2	TN	VN	5230.03	5.73614	20	PASS
11N40SISO	5230	Ant2	TN	VL	5230.00	0.00000	20	PASS
11N40SISO	5270	Ant1	TN	VH	5270.06	11.38520	20	PASS
11N40SISO	5270	Ant1	TN	VN	5270.06	11.38520	20	PASS
11N40SISO	5270	Ant1	TN	VL	5270.03	5.69260	20	PASS
11N40SISO	5270	Ant2	TN	VN	5269.97	-5.69260	20	PASS
11N40SISO	5270	Ant2	TN	VH	5270.03	5.69260	20	PASS
11N40SISO	5270	Ant2	TN	VL	5270.00	0.00000	20	PASS
11N40SISO	5310	Ant1	TN	VN	5310.06	11.29944	20	PASS
11N40SISO	5310	Ant1	TN	VH	5310.03	5.64972	20	PASS
11N40SISO	5310	Ant1	TN	VL	5310.03	5.64972	20	PASS
11N40SISO	5310	Ant2	TN	VH	5310.03	5.64972	20	PASS
11N40SISO	5310	Ant2	TN	VN	5310.03	5.64972	20	PASS
11N40SISO	5310	Ant2	TN	VL	5310.06	11.29944	20	PASS
11N40SISO	5510	Ant1	TN	VN	5510.03	5.44465	20	PASS
11N40SISO	5510	Ant1	TN	VH	5510.00	0.00000	20	PASS
11N40SISO	5510	Ant1	TN	VL	5510.00	0.00000	20	PASS
11N40SISO	5510	Ant2	TN	VL	5510.03	5.44465	20	PASS
11N40SISO	5510	Ant2	TN	VN	5510.03	5.44465	20	PASS
11N40SISO	5510	Ant2	TN	VH	5510.03	5.44465	20	PASS
11N40SISO	5550	Ant1	TN	VN	5550.06	10.81081	20	PASS
11N40SISO	5550	Ant1	TN	VL	5550.03	5.40541	20	PASS
11N40SISO	5550	Ant1	TN	VH	5550.03	5.40541	20	PASS
11N40SISO	5550	Ant2	TN	VN	5550.03	5.40541	20	PASS
11N40SISO	5550	Ant2	TN	VH	5550.03	5.40541	20	PASS
11N40SISO	5550	Ant2	TN	VL	5549.97	-5.40541	20	PASS
11N40SISO	5670	Ant1	TN	VH	5669.97	-5.29101	20	PASS
11N40SISO	5670	Ant1	TN	VN	5670.03	5.29101	20	PASS
11N40SISO	5670	Ant1	TN	VL	5669.97	-5.29101	20	PASS
11N40SISO	5670	Ant2	TN	VL	5670.03	5.29101	20	PASS
11N40SISO	5670	Ant2	TN	VN	5670.03	5.29101	20	PASS
11N40SISO	5670	Ant2	TN	VH	5670.00	0.00000	20	PASS
11N40SISO	5755	Ant1	TN	VL	5755.06	10.42572	20	PASS
11N40SISO	5755	Ant1	TN	VN	5755.09	15.63858	20	PASS
11N40SISO	5755	Ant1	TN	VH	5755.12	10.85143	20	PASS
11N40SISO	5755	Ant2	TN	VL	5755.06	10.42572	20	PASS

11N40SISO	5755	Ant2	TN	VN	5755.06	10.42572	20	PASS
11N40SISO	5755	Ant2	TN	VH	5755.06	10.42572	20	PASS
11N40SISO	5795	Ant1	TN	VL	5795.03	5.17688	20	PASS
11N40SISO	5795	Ant1	TN	VN	5795.03	5.17688	20	PASS
11N40SISO	5795	Ant1	TN	VH	5795.06	10.35375	20	PASS
11N40SISO	5795	Ant2	TN	VN	5795.00	0.00000	20	PASS
11N40SISO	5795	Ant2	TN	VL	5795.06	10.35375	20	PASS
11N40SISO	5795	Ant2	TN	VH	5795.06	10.35375	20	PASS
11AC20SISO	5180	Ant1	TN	VH	5180.00	0.00000	20	PASS
11AC20SISO	5180	Ant1	TN	VN	5179.96	-8.68726	20	PASS
11AC20SISO	5180	Ant1	TN	VL	5179.97	-5.79151	20	PASS
11AC20SISO	5180	Ant2	TN	VL	5180.05	8.68726	20	PASS
11AC20SISO	5180	Ant2	TN	VH	5180.05	8.68726	20	PASS
11AC20SISO	5180	Ant2	TN	VN	5180.02	2.89575	20	PASS
11AC20SISO	5200	Ant1	TN	VN	5200.00	0.00000	20	PASS
11AC20SISO	5200	Ant1	TN	VH	5200.00	0.00000	20	PASS
11AC20SISO	5200	Ant1	TN	VL	5199.97	-5.76923	20	PASS
11AC20SISO	5200	Ant2	TN	VH	5200.00	0.00000	20	PASS
11AC20SISO	5200	Ant2	TN	VN	5200.03	5.76923	20	PASS
11AC20SISO	5200	Ant2	TN	VL	5200.05	8.65385	20	PASS
11AC20SISO	5240	Ant1	TN	VL	5239.99	-2.86260	20	PASS
11AC20SISO	5240	Ant1	TN	VH	5240.03	5.72519	20	PASS
11AC20SISO	5240	Ant1	TN	VN	5240.05	8.58779	20	PASS
11AC20SISO	5240	Ant2	TN	VH	5240.00	0.00000	20	PASS
11AC20SISO	5240	Ant2	TN	VN	5240.00	0.00000	20	PASS
11AC20SISO	5240	Ant2	TN	VL	5240.03	5.72519	20	PASS
11AC20SISO	5260	Ant1	TN	VL	5260.00	0.00000	20	PASS
11AC20SISO	5260	Ant1	TN	VH	5260.02	2.85171	20	PASS
11AC20SISO	5260	Ant1	TN	VN	5259.96	-8.55513	20	PASS
11AC20SISO	5260	Ant2	TN	VN	5260.03	5.70342	20	PASS
11AC20SISO	5260	Ant2	TN	VL	5259.99	-2.85171	20	PASS
11AC20SISO	5260	Ant2	TN	VH	5260.03	5.70342	20	PASS
11AC20SISO	5280	Ant1	TN	VH	5280.00	0.00000	20	PASS
11AC20SISO	5280	Ant1	TN	VN	5280.02	2.84091	20	PASS
11AC20SISO	5280	Ant1	TN	VL	5280.02	2.84091	20	PASS
11AC20SISO	5280	Ant2	TN	VL	5280.02	2.84091	20	PASS
11AC20SISO	5280	Ant2	TN	VH	5280.02	2.84091	20	PASS
11AC20SISO	5280	Ant2	TN	VN	5280.02	2.84091	20	PASS
11AC20SISO	5320	Ant1	TN	VH	5320.03	5.63910	20	PASS
11AC20SISO	5320	Ant1	TN	VN	5320.00	0.00000	20	PASS

11AC20SISO	5320	Ant1	TN	VL	5320.02	2.81955	20	PASS
11AC20SISO	5320	Ant2	TN	VN	5320.06	11.27820	20	PASS
11AC20SISO	5320	Ant2	TN	VL	5320.03	5.63910	20	PASS
11AC20SISO	5320	Ant2	TN	VH	5320.03	5.63910	20	PASS
11AC20SISO	5500	Ant1	TN	VH	5500.03	5.45455	20	PASS
11AC20SISO	5500	Ant1	TN	VN	5500.06	10.90909	20	PASS
11AC20SISO	5500	Ant1	TN	VL	5500.03	5.45455	20	PASS
11AC20SISO	5500	Ant2	TN	VL	5500.06	10.90909	20	PASS
11AC20SISO	5500	Ant2	TN	VN	5500.03	5.45455	20	PASS
11AC20SISO	5500	Ant2	TN	VH	5500.05	8.18182	20	PASS
11AC20SISO	5580	Ant1	TN	VL	5579.99	-2.68817	20	PASS
11AC20SISO	5580	Ant1	TN	VN	5579.96	-8.06452	20	PASS
11AC20SISO	5580	Ant1	TN	VH	5580.02	2.68817	20	PASS
11AC20SISO	5580	Ant2	TN	VH	5580.00	0.00000	20	PASS
11AC20SISO	5580	Ant2	TN	VL	5580.00	0.00000	20	PASS
11AC20SISO	5580	Ant2	TN	VN	5580.02	2.68817	20	PASS
11AC20SISO	5700	Ant1	TN	VH	5700.08	13.15790	20	PASS
11AC20SISO	5700	Ant1	TN	VN	5700.09	15.78947	20	PASS
11AC20SISO	5700	Ant1	TN	VL	5700.09	15.78947	20	PASS
11AC20SISO	5700	Ant2	TN	VN	5700.05	7.89474	20	PASS
11AC20SISO	5700	Ant2	TN	VH	5700.03	5.26316	20	PASS
11AC20SISO	5700	Ant2	TN	VL	5700.06	10.52632	20	PASS
11AC20SISO	5745	Ant1	TN	VN	5745.09	15.66580	20	PASS
11AC20SISO	5745	Ant1	TN	VH	5745.09	15.66580	20	PASS
11AC20SISO	5745	Ant1	TN	VL	5745.09	15.66580	20	PASS
11AC20SISO	5745	Ant2	TN	VL	5745.05	7.83290	20	PASS
11AC20SISO	5745	Ant2	TN	VH	5745.06	10.44386	20	PASS
11AC20SISO	5745	Ant2	TN	VN	5745.03	5.22193	20	PASS
11AC20SISO	5785	Ant1	TN	VH	5785.03	5.18583	20	PASS
11AC20SISO	5785	Ant1	TN	VN	5785.02	2.59291	20	PASS
11AC20SISO	5785	Ant1	TN	VL	5785.02	2.59291	20	PASS
11AC20SISO	5785	Ant2	TN	VL	5785.06	10.37165	20	PASS
11AC20SISO	5785	Ant2	TN	VN	5785.02	2.59291	20	PASS
11AC20SISO	5785	Ant2	TN	VH	5785.00	0.00000	20	PASS
11AC20SISO	5825	Ant1	TN	VL	5825.05	7.72532	20	PASS
11AC20SISO	5825	Ant1	TN	VN	5825.06	10.30043	20	PASS
11AC20SISO	5825	Ant1	TN	VH	5825.06	10.30043	20	PASS
11AC20SISO	5825	Ant2	TN	VL	5825.03	5.15022	20	PASS
11AC20SISO	5825	Ant2	TN	VN	5825.06	10.30043	20	PASS
11AC20SISO	5825	Ant2	TN	VH	5824.99	-2.57511	20	PASS

11AC40SISO	5190	Ant1	TN	VN	5189.97	-5.78035	20	PASS
11AC40SISO	5190	Ant1	TN	VL	5189.97	-5.78035	20	PASS
11AC40SISO	5190	Ant1	TN	VH	5189.97	-5.78035	20	PASS
11AC40SISO	5190	Ant2	TN	VN	5190.03	5.78035	20	PASS
11AC40SISO	5190	Ant2	TN	VL	5190.03	5.78035	20	PASS
11AC40SISO	5190	Ant2	TN	VH	5190.03	5.78035	20	PASS
11AC40SISO	5230	Ant1	TN	VL	5229.97	-5.73614	20	PASS
11AC40SISO	5230	Ant1	TN	VN	5229.94	-11.47228	20	PASS
11AC40SISO	5230	Ant1	TN	VH	5229.94	-11.47228	20	PASS
11AC40SISO	5230	Ant2	TN	VL	5230.03	5.73614	20	PASS
11AC40SISO	5230	Ant2	TN	VH	5230.00	0.00000	20	PASS
11AC40SISO	5230	Ant2	TN	VN	5230.03	5.73614	20	PASS
11AC40SISO	5270	Ant1	TN	VL	5269.94	-11.38520	20	PASS
11AC40SISO	5270	Ant1	TN	VN	5269.97	-5.69260	20	PASS
11AC40SISO	5270	Ant1	TN	VH	5269.97	-5.69260	20	PASS
11AC40SISO	5270	Ant2	TN	VH	5270.03	5.69260	20	PASS
11AC40SISO	5270	Ant2	TN	VL	5270.00	0.00000	20	PASS
11AC40SISO	5270	Ant2	TN	VN	5270.03	5.69260	20	PASS
11AC40SISO	5310	Ant1	TN	VN	5310.00	0.00000	20	PASS
11AC40SISO	5310	Ant1	TN	VL	5309.97	-5.64972	20	PASS
11AC40SISO	5310	Ant1	TN	VH	5310.00	0.00000	20	PASS
11AC40SISO	5310	Ant2	TN	VN	5310.03	5.64972	20	PASS
11AC40SISO	5310	Ant2	TN	VH	5310.06	11.29944	20	PASS
11AC40SISO	5310	Ant2	TN	VL	5310.06	11.29944	20	PASS
11AC40SISO	5510	Ant1	TN	VL	5509.97	-5.44465	20	PASS
11AC40SISO	5510	Ant1	TN	VN	5509.97	-5.44465	20	PASS
11AC40SISO	5510	Ant1	TN	VH	5510.00	0.00000	20	PASS
11AC40SISO	5510	Ant2	TN	VH	5510.03	5.44465	20	PASS
11AC40SISO	5510	Ant2	TN	VN	5510.03	5.44465	20	PASS
11AC40SISO	5510	Ant2	TN	VL	5510.03	5.44465	20	PASS
11AC40SISO	5550	Ant1	TN	VL	5550.00	0.00000	20	PASS
11AC40SISO	5550	Ant1	TN	VH	5550.03	5.40541	20	PASS
11AC40SISO	5550	Ant1	TN	VN	5550.00	0.00000	20	PASS
11AC40SISO	5550	Ant2	TN	VL	5550.00	0.00000	20	PASS
11AC40SISO	5550	Ant2	TN	VH	5550.00	0.00000	20	PASS
11AC40SISO	5550	Ant2	TN	VN	5550.00	0.00000	20	PASS
11AC40SISO	5670	Ant1	TN	VN	5669.94	-10.58201	20	PASS
11AC40SISO	5670	Ant1	TN	VL	5669.94	-10.58201	20	PASS
11AC40SISO	5670	Ant1	TN	VH	5669.94	-10.58201	20	PASS
11AC40SISO	5670	Ant2	TN	VN	5669.97	-5.29101	20	PASS

11AC40SISO	5670	Ant2	TN	VL	5670.03	5.29101	20	PASS
11AC40SISO	5670	Ant2	TN	VH	5669.97	-5.29101	20	PASS
11AC40SISO	5755	Ant1	TN	VH	5755.06	10.42572	20	PASS
11AC40SISO	5755	Ant1	TN	VL	5755.06	10.42572	20	PASS
11AC40SISO	5755	Ant1	TN	VN	5755.06	10.42572	20	PASS
11AC40SISO	5755	Ant2	TN	VL	5755.03	5.21286	20	PASS
11AC40SISO	5755	Ant2	TN	VN	5755.03	5.21286	20	PASS
11AC40SISO	5755	Ant2	TN	VH	5755.00	0.00000	20	PASS
11AC40SISO	5795	Ant1	TN	VL	5795.06	10.35375	20	PASS
11AC40SISO	5795	Ant1	TN	VN	5795.06	10.35375	20	PASS
11AC40SISO	5795	Ant1	TN	VH	5795.03	5.17688	20	PASS
11AC40SISO	5795	Ant2	TN	VL	5795.03	5.17688	20	PASS
11AC40SISO	5795	Ant2	TN	VH	5795.06	10.35375	20	PASS
11AC40SISO	5795	Ant2	TN	VN	5795.03	5.17688	20	PASS
11AC80SISO	5210	Ant1	TN	VH	5210.12	13.03263	20	PASS
11AC80SISO	5210	Ant1	TN	VL	5209.94	-11.51632	20	PASS
11AC80SISO	5210	Ant1	TN	VN	5210.06	11.51632	20	PASS
11AC80SISO	5210	Ant2	TN	VH	5210.06	11.51632	20	PASS
11AC80SISO	5210	Ant2	TN	VN	5210.00	0.00000	20	PASS
11AC80SISO	5210	Ant2	TN	VL	5210.06	11.51632	20	PASS
11AC80SISO	5290	Ant1	TN	VN	5290.00	0.00000	20	PASS
11AC80SISO	5290	Ant1	TN	VH	5290.00	0.00000	20	PASS
11AC80SISO	5290	Ant1	TN	VL	5290.00	0.00000	20	PASS
11AC80SISO	5290	Ant2	TN	VL	5290.00	0.00000	20	PASS
11AC80SISO	5290	Ant2	TN	VH	5290.00	0.00000	20	PASS
11AC80SISO	5290	Ant2	TN	VN	5290.00	0.00000	20	PASS
11AC80SISO	5530	Ant1	TN	VL	5530.00	0.00000	20	PASS
11AC80SISO	5530	Ant1	TN	VN	5530.06	10.84991	20	PASS
11AC80SISO	5530	Ant1	TN	VH	5529.94	-10.84991	20	PASS
11AC80SISO	5530	Ant2	TN	VH	5530.00	0.00000	20	PASS
11AC80SISO	5530	Ant2	TN	VN	5529.94	-10.84991	20	PASS
11AC80SISO	5530	Ant2	TN	VL	5530.00	0.00000	20	PASS
11AC80SISO	5775	Ant1	TN	VL	5775.06	10.38961	20	PASS
11AC80SISO	5775	Ant1	TN	VH	5775.12	10.77922	20	PASS
11AC80SISO	5775	Ant1	TN	VN	5775.12	10.77922	20	PASS
11AC80SISO	5775	Ant2	TN	VH	5775.06	10.38961	20	PASS
11AC80SISO	5775	Ant2	TN	VL	5775.12	10.77922	20	PASS
11AC80SISO	5775	Ant2	TN	VN	5775.06	10.38961	20	PASS

Temperature vs. Frequency Stability

Test Mode	Test Channel	Ant	Volt.	Temp.	Deviation [MHz]	Deviation [ppm]	Limit [ppm]	Verdict
11A	5180	Ant1	VN	50	5180.03	5.79151	20	PASS
11A	5180	Ant1	VN	-30	5180.03	5.79151	20	PASS
11A	5180	Ant1	VN	40	5180.03	5.79151	20	PASS
11A	5180	Ant1	VN	30	5180.02	2.89575	20	PASS
11A	5180	Ant1	VN	20	5180.02	2.89575	20	PASS
11A	5180	Ant1	VN	10	5180.02	2.89575	20	PASS
11A	5180	Ant1	VN	0	5180.03	5.79151	20	PASS
11A	5180	Ant1	VN	-10	5180.03	5.79151	20	PASS
11A	5180	Ant1	VN	-20	5180.02	2.89575	20	PASS
11A	5180	Ant2	VN	50	5180.02	2.89575	20	PASS
11A	5180	Ant2	VN	-30	5180.02	2.89575	20	PASS
11A	5180	Ant2	VN	-10	5180.02	2.89575	20	PASS
11A	5180	Ant2	VN	0	5180.02	2.89575	20	PASS
11A	5180	Ant2	VN	10	5180.02	2.89575	20	PASS
11A	5180	Ant2	VN	20	5180.02	2.89575	20	PASS
11A	5180	Ant2	VN	30	5180.02	2.89575	20	PASS
11A	5180	Ant2	VN	40	5180.02	2.89575	20	PASS
11A	5180	Ant2	VN	-20	5180.00	0.00000	20	PASS
11A	5200	Ant1	VN	-30	5200.02	2.88462	20	PASS
11A	5200	Ant1	VN	50	5200.03	5.76923	20	PASS
11A	5200	Ant1	VN	40	5200.00	0.00000	20	PASS
11A	5200	Ant1	VN	30	5200.03	5.76923	20	PASS
11A	5200	Ant1	VN	20	5200.03	5.76923	20	PASS
11A	5200	Ant1	VN	10	5200.03	5.76923	20	PASS
11A	5200	Ant1	VN	0	5200.03	5.76923	20	PASS
11A	5200	Ant1	VN	-10	5200.02	2.88462	20	PASS
11A	5200	Ant1	VN	-20	5200.02	2.88462	20	PASS
11A	5200	Ant2	VN	-20	5200.03	5.76923	20	PASS
11A	5200	Ant2	VN	-30	5200.02	2.88462	20	PASS
11A	5200	Ant2	VN	40	5200.00	0.00000	20	PASS
11A	5200	Ant2	VN	30	5200.00	0.00000	20	PASS
11A	5200	Ant2	VN	20	5200.02	2.88462	20	PASS
11A	5200	Ant2	VN	10	5200.03	5.76923	20	PASS
11A	5200	Ant2	VN	0	5200.00	0.00000	20	PASS
11A	5200	Ant2	VN	-10	5200.00	0.00000	20	PASS
11A	5200	Ant2	VN	50	5200.03	5.76923	20	PASS
11A	5240	Ant1	VN	0	5240.03	5.72519	20	PASS
11A	5240	Ant1	VN	-20	5240.05	8.58779	20	PASS

11A	5240	Ant1	VN	10	5240.03	5.72519	20	PASS
11A	5240	Ant1	VN	20	5240.02	2.86260	20	PASS
11A	5240	Ant1	VN	30	5240.03	5.72519	20	PASS
11A	5240	Ant1	VN	40	5240.02	2.86260	20	PASS
11A	5240	Ant1	VN	50	5240.03	5.72519	20	PASS
11A	5240	Ant1	VN	-10	5240.02	2.86260	20	PASS
11A	5240	Ant1	VN	-30	5240.03	5.72519	20	PASS
11A	5240	Ant2	VN	40	5240.02	2.86260	20	PASS
11A	5240	Ant2	VN	30	5240.00	0.00000	20	PASS
11A	5240	Ant2	VN	20	5239.99	-2.86260	20	PASS
11A	5240	Ant2	VN	10	5240.02	2.86260	20	PASS
11A	5240	Ant2	VN	0	5240.00	0.00000	20	PASS
11A	5240	Ant2	VN	-10	5240.02	2.86260	20	PASS
11A	5240	Ant2	VN	-20	5240.02	2.86260	20	PASS
11A	5240	Ant2	VN	50	5240.02	2.86260	20	PASS
11A	5240	Ant2	VN	-30	5240.02	2.86260	20	PASS
11A	5260	Ant1	VN	-30	5260.00	0.00000	20	PASS
11A	5260	Ant1	VN	-10	5260.02	2.85171	20	PASS
11A	5260	Ant1	VN	0	5260.00	0.00000	20	PASS
11A	5260	Ant1	VN	10	5260.02	2.85171	20	PASS
11A	5260	Ant1	VN	20	5260.02	2.85171	20	PASS
11A	5260	Ant1	VN	30	5260.00	0.00000	20	PASS
11A	5260	Ant1	VN	40	5260.02	2.85171	20	PASS
11A	5260	Ant1	VN	50	5260.02	2.85171	20	PASS
11A	5260	Ant1	VN	-20	5260.00	0.00000	20	PASS
11A	5260	Ant2	VN	-30	5260.00	0.00000	20	PASS
11A	5260	Ant2	VN	50	5259.99	-2.85171	20	PASS
11A	5260	Ant2	VN	40	5260.00	0.00000	20	PASS
11A	5260	Ant2	VN	30	5260.00	0.00000	20	PASS
11A	5260	Ant2	VN	20	5260.02	2.85171	20	PASS
11A	5260	Ant2	VN	10	5260.02	2.85171	20	PASS
11A	5260	Ant2	VN	0	5260.02	2.85171	20	PASS
11A	5260	Ant2	VN	-10	5260.00	0.00000	20	PASS
11A	5260	Ant2	VN	-20	5259.99	-2.85171	20	PASS
11A	5280	Ant1	VN	-10	5280.05	8.52273	20	PASS
11A	5280	Ant1	VN	40	5280.03	5.68182	20	PASS
11A	5280	Ant1	VN	30	5280.02	2.84091	20	PASS
11A	5280	Ant1	VN	20	5280.05	8.52273	20	PASS
11A	5280	Ant1	VN	-30	5280.03	5.68182	20	PASS
11A	5280	Ant1	VN	0	5280.03	5.68182	20	PASS

11A	5280	Ant1	VN	-20	5280.03	5.68182	20	PASS
11A	5280	Ant1	VN	50	5280.03	5.68182	20	PASS
11A	5280	Ant1	VN	10	5280.03	5.68182	20	PASS
11A	5280	Ant2	VN	-30	5280.02	2.84091	20	PASS
11A	5280	Ant2	VN	40	5280.02	2.84091	20	PASS
11A	5280	Ant2	VN	50	5280.03	5.68182	20	PASS
11A	5280	Ant2	VN	30	5280.03	5.68182	20	PASS
11A	5280	Ant2	VN	20	5280.02	2.84091	20	PASS
11A	5280	Ant2	VN	10	5280.05	8.52273	20	PASS
11A	5280	Ant2	VN	0	5280.03	5.68182	20	PASS
11A	5280	Ant2	VN	-10	5280.00	0.00000	20	PASS
11A	5280	Ant2	VN	-20	5280.02	2.84091	20	PASS
11A	5320	Ant1	VN	30	5320.03	5.63910	20	PASS
11A	5320	Ant1	VN	-30	5320.03	5.63910	20	PASS
11A	5320	Ant1	VN	20	5320.03	5.63910	20	PASS
11A	5320	Ant1	VN	10	5320.02	2.81955	20	PASS
11A	5320	Ant1	VN	0	5320.03	5.63910	20	PASS
11A	5320	Ant1	VN	50	5320.03	5.63910	20	PASS
11A	5320	Ant1	VN	-10	5320.02	2.81955	20	PASS
11A	5320	Ant1	VN	-20	5320.03	5.63910	20	PASS
11A	5320	Ant1	VN	40	5320.02	2.81955	20	PASS
11A	5320	Ant2	VN	-30	5320.03	5.63910	20	PASS
11A	5320	Ant2	VN	40	5320.02	2.81955	20	PASS
11A	5320	Ant2	VN	30	5320.02	2.81955	20	PASS
11A	5320	Ant2	VN	20	5320.02	2.81955	20	PASS
11A	5320	Ant2	VN	10	5320.03	5.63910	20	PASS
11A	5320	Ant2	VN	0	5320.03	5.63910	20	PASS
11A	5320	Ant2	VN	-10	5320.03	5.63910	20	PASS
11A	5320	Ant2	VN	50	5320.02	2.81955	20	PASS
11A	5320	Ant2	VN	-20	5320.03	5.63910	20	PASS
11A	5500	Ant1	VN	40	5500.03	5.45455	20	PASS
11A	5500	Ant1	VN	-20	5500.03	5.45455	20	PASS
11A	5500	Ant1	VN	-10	5500.02	2.72727	20	PASS
11A	5500	Ant1	VN	0	5500.03	5.45455	20	PASS
11A	5500	Ant1	VN	10	5500.03	5.45455	20	PASS
11A	5500	Ant1	VN	20	5500.03	5.45455	20	PASS
11A	5500	Ant1	VN	30	5500.03	5.45455	20	PASS
11A	5500	Ant1	VN	50	5500.02	2.72727	20	PASS
11A	5500	Ant1	VN	-30	5500.03	5.45455	20	PASS
11A	5500	Ant2	VN	-30	5500.03	5.45455	20	PASS

11A	5500	Ant2	VN	40	5500.03	5.45455	20	PASS
11A	5500	Ant2	VN	30	5500.03	5.45455	20	PASS
11A	5500	Ant2	VN	20	5500.03	5.45455	20	PASS
11A	5500	Ant2	VN	10	5500.02	2.72727	20	PASS
11A	5500	Ant2	VN	0	5500.03	5.45455	20	PASS
11A	5500	Ant2	VN	-10	5500.05	8.18182	20	PASS
11A	5500	Ant2	VN	50	5500.03	5.45455	20	PASS
11A	5500	Ant2	VN	-20	5500.02	2.72727	20	PASS
11A	5580	Ant1	VN	40	5580.02	2.68817	20	PASS
11A	5580	Ant1	VN	-10	5580.00	0.00000	20	PASS
11A	5580	Ant1	VN	0	5580.02	2.68817	20	PASS
11A	5580	Ant1	VN	10	5580.02	2.68817	20	PASS
11A	5580	Ant1	VN	20	5580.00	0.00000	20	PASS
11A	5580	Ant1	VN	30	5580.02	2.68817	20	PASS
11A	5580	Ant1	VN	50	5580.03	5.37634	20	PASS
11A	5580	Ant1	VN	-30	5580.00	0.00000	20	PASS
11A	5580	Ant1	VN	-20	5580.02	2.68817	20	PASS
11A	5580	Ant2	VN	-30	5580.00	0.00000	20	PASS
11A	5580	Ant2	VN	40	5579.99	-2.68817	20	PASS
11A	5580	Ant2	VN	30	5579.99	-2.68817	20	PASS
11A	5580	Ant2	VN	20	5579.99	-2.68817	20	PASS
11A	5580	Ant2	VN	10	5579.99	-2.68817	20	PASS
11A	5580	Ant2	VN	0	5579.99	-2.68817	20	PASS
11A	5580	Ant2	VN	-10	5579.99	-2.68817	20	PASS
11A	5580	Ant2	VN	50	5579.99	-2.68817	20	PASS
11A	5580	Ant2	VN	-20	5579.99	-2.68817	20	PASS
11A	5700	Ant1	VN	-30	5700.08	13.15790	20	PASS
11A	5700	Ant1	VN	-10	5700.06	10.52632	20	PASS
11A	5700	Ant1	VN	0	5700.09	15.78947	20	PASS
11A	5700	Ant1	VN	10	5700.08	13.15790	20	PASS
11A	5700	Ant1	VN	20	5700.06	10.52632	20	PASS
11A	5700	Ant1	VN	30	5700.06	10.52632	20	PASS
11A	5700	Ant1	VN	40	5700.08	13.15790	20	PASS
11A	5700	Ant1	VN	50	5700.08	13.15790	20	PASS
11A	5700	Ant1	VN	-20	5700.06	10.52632	20	PASS
11A	5700	Ant2	VN	-30	5700.09	15.78947	20	PASS
11A	5700	Ant2	VN	40	5700.09	15.78947	20	PASS
11A	5700	Ant2	VN	30	5700.08	13.15790	20	PASS
11A	5700	Ant2	VN	20	5700.06	10.52632	20	PASS
11A	5700	Ant2	VN	10	5700.08	13.15790	20	PASS

11A	5700	Ant2	VN	0	5700.09	15.78947	20	PASS
11A	5700	Ant2	VN	-10	5700.08	13.15790	20	PASS
11A	5700	Ant2	VN	50	5700.08	13.15790	20	PASS
11A	5700	Ant2	VN	-20	5700.08	13.15790	20	PASS
11A	5745	Ant1	VN	-30	5745.05	7.83290	20	PASS
11A	5745	Ant1	VN	-10	5745.03	5.22193	20	PASS
11A	5745	Ant1	VN	0	5745.05	7.83290	20	PASS
11A	5745	Ant1	VN	10	5745.05	7.83290	20	PASS
11A	5745	Ant1	VN	20	5745.05	7.83290	20	PASS
11A	5745	Ant1	VN	30	5745.05	7.83290	20	PASS
11A	5745	Ant1	VN	40	5745.06	10.44386	20	PASS
11A	5745	Ant1	VN	50	5745.05	7.83290	20	PASS
11A	5745	Ant1	VN	-20	5745.05	7.83290	20	PASS
11A	5745	Ant2	VN	-30	5745.06	10.44386	20	PASS
11A	5745	Ant2	VN	40	5745.08	13.05483	20	PASS
11A	5745	Ant2	VN	30	5745.08	13.05483	20	PASS
11A	5745	Ant2	VN	20	5745.09	15.66580	20	PASS
11A	5745	Ant2	VN	10	5745.06	10.44386	20	PASS
11A	5745	Ant2	VN	0	5745.06	10.44386	20	PASS
11A	5745	Ant2	VN	-10	5745.08	13.05483	20	PASS
11A	5745	Ant2	VN	50	5745.06	10.44386	20	PASS
11A	5745	Ant2	VN	-20	5745.06	10.44386	20	PASS
11A	5785	Ant1	VN	-30	5785.03	5.18583	20	PASS
11A	5785	Ant1	VN	-10	5785.02	2.59291	20	PASS
11A	5785	Ant1	VN	0	5785.03	5.18583	20	PASS
11A	5785	Ant1	VN	10	5785.03	5.18583	20	PASS
11A	5785	Ant1	VN	20	5785.03	5.18583	20	PASS
11A	5785	Ant1	VN	30	5785.03	5.18583	20	PASS
11A	5785	Ant1	VN	40	5785.03	5.18583	20	PASS
11A	5785	Ant1	VN	50	5785.03	5.18583	20	PASS
11A	5785	Ant1	VN	-20	5785.03	5.18583	20	PASS
11A	5785	Ant2	VN	-30	5785.02	2.59291	20	PASS
11A	5785	Ant2	VN	50	5785.03	5.18583	20	PASS
11A	5785	Ant2	VN	40	5785.02	2.59291	20	PASS
11A	5785	Ant2	VN	30	5785.02	2.59291	20	PASS
11A	5785	Ant2	VN	20	5785.03	5.18583	20	PASS
11A	5785	Ant2	VN	10	5785.03	5.18583	20	PASS
11A	5785	Ant2	VN	0	5785.03	5.18583	20	PASS
11A	5785	Ant2	VN	-10	5785.03	5.18583	20	PASS
11A	5785	Ant2	VN	-20	5785.03	5.18583	20	PASS

11A	5825	Ant1	VN	0	5825.03	5.15022	20	PASS
11A	5825	Ant1	VN	50	5825.03	5.15022	20	PASS
11A	5825	Ant1	VN	40	5825.05	7.72532	20	PASS
11A	5825	Ant1	VN	30	5825.03	5.15022	20	PASS
11A	5825	Ant1	VN	10	5825.05	7.72532	20	PASS
11A	5825	Ant1	VN	-10	5825.05	7.72532	20	PASS
11A	5825	Ant1	VN	-20	5825.03	5.15022	20	PASS
11A	5825	Ant1	VN	-30	5825.05	7.72532	20	PASS
11A	5825	Ant1	VN	20	5825.06	10.30043	20	PASS
11A	5825	Ant2	VN	40	5825.00	0.00000	20	PASS
11A	5825	Ant2	VN	30	5825.02	2.57511	20	PASS
11A	5825	Ant2	VN	20	5825.02	2.57511	20	PASS
11A	5825	Ant2	VN	10	5825.00	0.00000	20	PASS
11A	5825	Ant2	VN	0	5825.02	2.57511	20	PASS
11A	5825	Ant2	VN	-10	5825.02	2.57511	20	PASS
11A	5825	Ant2	VN	-20	5825.02	2.57511	20	PASS
11A	5825	Ant2	VN	-30	5825.02	2.57511	20	PASS
11A	5825	Ant2	VN	50	5825.00	0.00000	20	PASS
11N20SISO	5180	Ant1	VN	0	5179.97	-5.79151	20	PASS
11N20SISO	5180	Ant1	VN	40	5179.97	-5.79151	20	PASS
11N20SISO	5180	Ant1	VN	-10	5179.96	-8.68726	20	PASS
11N20SISO	5180	Ant1	VN	30	5179.97	-5.79151	20	PASS
11N20SISO	5180	Ant1	VN	-30	5179.97	-5.79151	20	PASS
11N20SISO	5180	Ant1	VN	20	5179.96	-8.68726	20	PASS
11N20SISO	5180	Ant1	VN	10	5179.94	-11.58301	20	PASS
11N20SISO	5180	Ant1	VN	-20	5179.97	-5.79151	20	PASS
11N20SISO	5180	Ant1	VN	50	5179.93	-14.47876	20	PASS
11N20SISO	5180	Ant2	VN	-30	5180.00	0.00000	20	PASS
11N20SISO	5180	Ant2	VN	50	5180.03	5.79151	20	PASS
11N20SISO	5180	Ant2	VN	40	5180.03	5.79151	20	PASS
11N20SISO	5180	Ant2	VN	30	5180.02	2.89575	20	PASS
11N20SISO	5180	Ant2	VN	20	5180.05	8.68726	20	PASS
11N20SISO	5180	Ant2	VN	10	5180.06	11.58301	20	PASS
11N20SISO	5180	Ant2	VN	0	5180.06	11.58301	20	PASS
11N20SISO	5180	Ant2	VN	-10	5180.05	8.68726	20	PASS
11N20SISO	5180	Ant2	VN	-20	5180.02	2.89575	20	PASS
11N20SISO	5200	Ant1	VN	50	5199.99	-2.88462	20	PASS
11N20SISO	5200	Ant1	VN	30	5199.97	-5.76923	20	PASS
11N20SISO	5200	Ant1	VN	20	5200.00	0.00000	20	PASS
11N20SISO	5200	Ant1	VN	10	5200.00	0.00000	20	PASS

11N20SISO	5200	Ant1	VN	0	5199.99	-2.88462	20	PASS
11N20SISO	5200	Ant1	VN	-10	5200.02	2.88462	20	PASS
11N20SISO	5200	Ant1	VN	-20	5199.99	-2.88462	20	PASS
11N20SISO	5200	Ant1	VN	-30	5199.97	-5.76923	20	PASS
11N20SISO	5200	Ant1	VN	40	5199.99	-2.88462	20	PASS
11N20SISO	5200	Ant2	VN	-30	5200.03	5.76923	20	PASS
11N20SISO	5200	Ant2	VN	-10	5200.02	2.88462	20	PASS
11N20SISO	5200	Ant2	VN	0	5200.05	8.65385	20	PASS
11N20SISO	5200	Ant2	VN	10	5200.02	2.88462	20	PASS
11N20SISO	5200	Ant2	VN	20	5200.03	5.76923	20	PASS
11N20SISO	5200	Ant2	VN	-20	5200.05	8.65385	20	PASS
11N20SISO	5200	Ant2	VN	50	5200.05	8.65385	20	PASS
11N20SISO	5200	Ant2	VN	40	5200.03	5.76923	20	PASS
11N20SISO	5200	Ant2	VN	30	5200.05	8.65385	20	PASS
11N20SISO	5240	Ant1	VN	10	5240.02	2.86260	20	PASS
11N20SISO	5240	Ant1	VN	50	5240.00	0.00000	20	PASS
11N20SISO	5240	Ant1	VN	40	5240.00	0.00000	20	PASS
11N20SISO	5240	Ant1	VN	20	5240.00	0.00000	20	PASS
11N20SISO	5240	Ant1	VN	0	5240.02	2.86260	20	PASS
11N20SISO	5240	Ant1	VN	-20	5240.02	2.86260	20	PASS
11N20SISO	5240	Ant1	VN	-30	5240.00	0.00000	20	PASS
11N20SISO	5240	Ant1	VN	30	5240.02	2.86260	20	PASS
11N20SISO	5240	Ant1	VN	-10	5239.97	-5.72519	20	PASS
11N20SISO	5240	Ant2	VN	-30	5240.03	5.72519	20	PASS
11N20SISO	5240	Ant2	VN	50	5240.00	0.00000	20	PASS
11N20SISO	5240	Ant2	VN	40	5240.00	0.00000	20	PASS
11N20SISO	5240	Ant2	VN	30	5240.00	0.00000	20	PASS
11N20SISO	5240	Ant2	VN	20	5240.06	11.45038	20	PASS
11N20SISO	5240	Ant2	VN	10	5240.06	11.45038	20	PASS
11N20SISO	5240	Ant2	VN	0	5240.03	5.72519	20	PASS
11N20SISO	5240	Ant2	VN	-10	5240.03	5.72519	20	PASS
11N20SISO	5240	Ant2	VN	-20	5240.06	11.45038	20	PASS
11N20SISO	5260	Ant1	VN	50	5260.00	0.00000	20	PASS
11N20SISO	5260	Ant1	VN	30	5260.05	8.55513	20	PASS
11N20SISO	5260	Ant1	VN	20	5260.02	2.85171	20	PASS
11N20SISO	5260	Ant1	VN	10	5260.02	2.85171	20	PASS
11N20SISO	5260	Ant1	VN	0	5260.02	2.85171	20	PASS
11N20SISO	5260	Ant1	VN	-10	5260.05	8.55513	20	PASS
11N20SISO	5260	Ant1	VN	-20	5260.02	2.85171	20	PASS
11N20SISO	5260	Ant1	VN	-30	5259.99	-2.85171	20	PASS

11N20SISO	5260	Ant1	VN	40	5260.03	5.70342	20	PASS
11N20SISO	5260	Ant2	VN	-30	5260.02	2.85171	20	PASS
11N20SISO	5260	Ant2	VN	-10	5259.99	-2.85171	20	PASS
11N20SISO	5260	Ant2	VN	0	5259.99	-2.85171	20	PASS
11N20SISO	5260	Ant2	VN	10	5260.03	5.70342	20	PASS
11N20SISO	5260	Ant2	VN	20	5260.03	5.70342	20	PASS
11N20SISO	5260	Ant2	VN	-20	5260.02	2.85171	20	PASS
11N20SISO	5260	Ant2	VN	50	5260.03	5.70342	20	PASS
11N20SISO	5260	Ant2	VN	40	5260.02	2.85171	20	PASS
11N20SISO	5260	Ant2	VN	30	5260.05	8.55513	20	PASS
11N20SISO	5280	Ant1	VN	10	5280.03	5.68182	20	PASS
11N20SISO	5280	Ant1	VN	50	5280.03	5.68182	20	PASS
11N20SISO	5280	Ant1	VN	40	5280.03	5.68182	20	PASS
11N20SISO	5280	Ant1	VN	20	5280.06	11.36364	20	PASS
11N20SISO	5280	Ant1	VN	0	5280.03	5.68182	20	PASS
11N20SISO	5280	Ant1	VN	-20	5280.03	5.68182	20	PASS
11N20SISO	5280	Ant1	VN	-30	5280.05	8.52273	20	PASS
11N20SISO	5280	Ant1	VN	30	5280.03	5.68182	20	PASS
11N20SISO	5280	Ant1	VN	-10	5280.05	8.52273	20	PASS
11N20SISO	5280	Ant2	VN	-30	5280.06	11.36364	20	PASS
11N20SISO	5280	Ant2	VN	50	5280.05	8.52273	20	PASS
11N20SISO	5280	Ant2	VN	40	5280.02	2.84091	20	PASS
11N20SISO	5280	Ant2	VN	30	5280.05	8.52273	20	PASS
11N20SISO	5280	Ant2	VN	20	5280.02	2.84091	20	PASS
11N20SISO	5280	Ant2	VN	10	5280.03	5.68182	20	PASS
11N20SISO	5280	Ant2	VN	0	5280.05	8.52273	20	PASS
11N20SISO	5280	Ant2	VN	-10	5280.03	5.68182	20	PASS
11N20SISO	5280	Ant2	VN	-20	5280.02	2.84091	20	PASS
11N20SISO	5320	Ant1	VN	50	5320.00	0.00000	20	PASS
11N20SISO	5320	Ant1	VN	30	5320.03	5.63910	20	PASS
11N20SISO	5320	Ant1	VN	20	5320.02	2.81955	20	PASS
11N20SISO	5320	Ant1	VN	10	5320.03	5.63910	20	PASS
11N20SISO	5320	Ant1	VN	0	5320.03	5.63910	20	PASS
11N20SISO	5320	Ant1	VN	-10	5320.03	5.63910	20	PASS
11N20SISO	5320	Ant1	VN	-20	5320.03	5.63910	20	PASS
11N20SISO	5320	Ant1	VN	-30	5320.03	5.63910	20	PASS
11N20SISO	5320	Ant1	VN	40	5320.00	0.00000	20	PASS
11N20SISO	5320	Ant2	VN	-30	5320.02	2.81955	20	PASS
11N20SISO	5320	Ant2	VN	-10	5320.05	8.45865	20	PASS
11N20SISO	5320	Ant2	VN	0	5320.02	2.81955	20	PASS

11N20SISO	5320	Ant2	VN	10	5319.99	-2.81955	20	PASS
11N20SISO	5320	Ant2	VN	20	5320.02	2.81955	20	PASS
11N20SISO	5320	Ant2	VN	-20	5320.03	5.63910	20	PASS
11N20SISO	5320	Ant2	VN	50	5320.03	5.63910	20	PASS
11N20SISO	5320	Ant2	VN	40	5320.02	2.81955	20	PASS
11N20SISO	5320	Ant2	VN	30	5320.02	2.81955	20	PASS
11N20SISO	5500	Ant1	VN	10	5500.03	5.45455	20	PASS
11N20SISO	5500	Ant1	VN	50	5500.00	0.00000	20	PASS
11N20SISO	5500	Ant1	VN	40	5500.00	0.00000	20	PASS
11N20SISO	5500	Ant1	VN	20	5500.02	2.72727	20	PASS
11N20SISO	5500	Ant1	VN	0	5500.05	8.18182	20	PASS
11N20SISO	5500	Ant1	VN	-20	5500.02	2.72727	20	PASS
11N20SISO	5500	Ant1	VN	-30	5500.03	5.45455	20	PASS
11N20SISO	5500	Ant1	VN	30	5500.00	0.00000	20	PASS
11N20SISO	5500	Ant1	VN	-10	5500.00	0.00000	20	PASS
11N20SISO	5500	Ant2	VN	40	5500.02	2.72727	20	PASS
11N20SISO	5500	Ant2	VN	30	5500.06	10.90909	20	PASS
11N20SISO	5500	Ant2	VN	20	5500.00	0.00000	20	PASS
11N20SISO	5500	Ant2	VN	10	5500.03	5.45455	20	PASS
11N20SISO	5500	Ant2	VN	0	5500.00	0.00000	20	PASS
11N20SISO	5500	Ant2	VN	-10	5500.00	0.00000	20	PASS
11N20SISO	5500	Ant2	VN	-30	5500.00	0.00000	20	PASS
11N20SISO	5500	Ant2	VN	50	5500.05	8.18182	20	PASS
11N20SISO	5500	Ant2	VN	-20	5500.03	5.45455	20	PASS
11N20SISO	5580	Ant1	VN	40	5580.02	2.68817	20	PASS
11N20SISO	5580	Ant1	VN	-30	5580.03	5.37634	20	PASS
11N20SISO	5580	Ant1	VN	30	5580.03	5.37634	20	PASS
11N20SISO	5580	Ant1	VN	20	5580.02	2.68817	20	PASS
11N20SISO	5580	Ant1	VN	10	5580.03	5.37634	20	PASS
11N20SISO	5580	Ant1	VN	0	5580.00	0.00000	20	PASS
11N20SISO	5580	Ant1	VN	-10	5580.02	2.68817	20	PASS
11N20SISO	5580	Ant1	VN	-20	5580.03	5.37634	20	PASS
11N20SISO	5580	Ant1	VN	50	5580.00	0.00000	20	PASS
11N20SISO	5580	Ant2	VN	50	5580.00	0.00000	20	PASS
11N20SISO	5580	Ant2	VN	-10	5579.99	-2.68817	20	PASS
11N20SISO	5580	Ant2	VN	0	5580.00	0.00000	20	PASS
11N20SISO	5580	Ant2	VN	10	5579.97	-5.37634	20	PASS
11N20SISO	5580	Ant2	VN	20	5579.99	-2.68817	20	PASS
11N20SISO	5580	Ant2	VN	30	5579.99	-2.68817	20	PASS
11N20SISO	5580	Ant2	VN	40	5580.02	2.68817	20	PASS

11N20SISO	5580	Ant2	VN	-20	5580.00	0.00000	20	PASS
11N20SISO	5580	Ant2	VN	-30	5579.99	-2.68817	20	PASS
11N20SISO	5700	Ant1	VN	50	5700.14	13.68421	20	PASS
11N20SISO	5700	Ant1	VN	40	5700.08	13.15790	20	PASS
11N20SISO	5700	Ant1	VN	30	5700.06	10.52632	20	PASS
11N20SISO	5700	Ant1	VN	20	5700.09	15.78947	20	PASS
11N20SISO	5700	Ant1	VN	10	5700.09	15.78947	20	PASS
11N20SISO	5700	Ant1	VN	0	5700.11	18.42105	20	PASS
11N20SISO	5700	Ant1	VN	-30	5700.09	15.78947	20	PASS
11N20SISO	5700	Ant1	VN	-10	5700.08	13.15790	20	PASS
11N20SISO	5700	Ant1	VN	-20	5700.08	13.15790	20	PASS
11N20SISO	5700	Ant2	VN	50	5700.05	7.89474	20	PASS
11N20SISO	5700	Ant2	VN	-30	5700.09	15.78947	20	PASS
11N20SISO	5700	Ant2	VN	-20	5700.05	7.89474	20	PASS
11N20SISO	5700	Ant2	VN	-10	5700.06	10.52632	20	PASS
11N20SISO	5700	Ant2	VN	0	5700.06	10.52632	20	PASS
11N20SISO	5700	Ant2	VN	10	5700.09	15.78947	20	PASS
11N20SISO	5700	Ant2	VN	20	5700.11	18.42105	20	PASS
11N20SISO	5700	Ant2	VN	30	5700.08	13.15790	20	PASS
11N20SISO	5700	Ant2	VN	40	5700.06	10.52632	20	PASS
11N20SISO	5745	Ant1	VN	30	5745.08	13.05483	20	PASS
11N20SISO	5745	Ant1	VN	20	5745.06	10.44386	20	PASS
11N20SISO	5745	Ant1	VN	10	5745.08	13.05483	20	PASS
11N20SISO	5745	Ant1	VN	0	5745.08	13.05483	20	PASS
11N20SISO	5745	Ant1	VN	-10	5745.08	13.05483	20	PASS
11N20SISO	5745	Ant1	VN	-20	5745.06	10.44386	20	PASS
11N20SISO	5745	Ant1	VN	50	5745.11	18.27676	20	PASS
11N20SISO	5745	Ant1	VN	-30	5745.05	7.83290	20	PASS
11N20SISO	5745	Ant1	VN	40	5745.06	10.44386	20	PASS
11N20SISO	5745	Ant2	VN	40	5745.06	10.44386	20	PASS
11N20SISO	5745	Ant2	VN	-30	5745.03	5.22193	20	PASS
11N20SISO	5745	Ant2	VN	-10	5745.03	5.22193	20	PASS
11N20SISO	5745	Ant2	VN	0	5745.03	5.22193	20	PASS
11N20SISO	5745	Ant2	VN	10	5745.05	7.83290	20	PASS
11N20SISO	5745	Ant2	VN	20	5745.08	13.05483	20	PASS
11N20SISO	5745	Ant2	VN	-20	5745.03	5.22193	20	PASS
11N20SISO	5745	Ant2	VN	50	5745.06	10.44386	20	PASS
11N20SISO	5745	Ant2	VN	30	5745.08	13.05483	20	PASS
11N20SISO	5785	Ant1	VN	10	5785.02	2.59291	20	PASS
11N20SISO	5785	Ant1	VN	50	5785.03	5.18583	20	PASS

11N20SISO	5785	Ant1	VN	40	5785.03	5.18583	20	PASS
11N20SISO	5785	Ant1	VN	20	5785.05	7.77874	20	PASS
11N20SISO	5785	Ant1	VN	0	5785.08	12.96456	20	PASS
11N20SISO	5785	Ant1	VN	-10	5785.06	10.37165	20	PASS
11N20SISO	5785	Ant1	VN	-30	5785.03	5.18583	20	PASS
11N20SISO	5785	Ant1	VN	30	5785.03	5.18583	20	PASS
11N20SISO	5785	Ant1	VN	-20	5785.05	7.77874	20	PASS
11N20SISO	5785	Ant2	VN	-20	5785.00	0.00000	20	PASS
11N20SISO	5785	Ant2	VN	-30	5784.99	-2.59291	20	PASS
11N20SISO	5785	Ant2	VN	50	5784.99	-2.59291	20	PASS
11N20SISO	5785	Ant2	VN	40	5785.02	2.59291	20	PASS
11N20SISO	5785	Ant2	VN	30	5785.02	2.59291	20	PASS
11N20SISO	5785	Ant2	VN	20	5785.03	5.18583	20	PASS
11N20SISO	5785	Ant2	VN	10	5785.03	5.18583	20	PASS
11N20SISO	5785	Ant2	VN	0	5785.00	0.00000	20	PASS
11N20SISO	5785	Ant2	VN	-10	5784.99	-2.59291	20	PASS
11N20SISO	5825	Ant1	VN	30	5825.05	7.72532	20	PASS
11N20SISO	5825	Ant1	VN	20	5825.05	7.72532	20	PASS
11N20SISO	5825	Ant1	VN	10	5825.08	12.87554	20	PASS
11N20SISO	5825	Ant1	VN	0	5825.03	5.15022	20	PASS
11N20SISO	5825	Ant1	VN	-10	5825.05	7.72532	20	PASS
11N20SISO	5825	Ant1	VN	-20	5825.03	5.15022	20	PASS
11N20SISO	5825	Ant1	VN	50	5825.02	2.57511	20	PASS
11N20SISO	5825	Ant1	VN	-30	5825.05	7.72532	20	PASS
11N20SISO	5825	Ant1	VN	40	5825.06	10.30043	20	PASS
11N20SISO	5825	Ant2	VN	-10	5825.02	2.57511	20	PASS
11N20SISO	5825	Ant2	VN	40	5825.00	0.00000	20	PASS
11N20SISO	5825	Ant2	VN	-30	5824.97	-5.15022	20	PASS
11N20SISO	5825	Ant2	VN	30	5825.02	2.57511	20	PASS
11N20SISO	5825	Ant2	VN	20	5825.03	5.15022	20	PASS
11N20SISO	5825	Ant2	VN	10	5825.03	5.15022	20	PASS
11N20SISO	5825	Ant2	VN	50	5825.00	0.00000	20	PASS
11N20SISO	5825	Ant2	VN	-20	5824.97	-5.15022	20	PASS
11N20SISO	5825	Ant2	VN	0	5825.00	0.00000	20	PASS
11N40SISO	5190	Ant1	VN	10	5190.03	5.78035	20	PASS
11N40SISO	5190	Ant1	VN	50	5190.06	11.56069	20	PASS
11N40SISO	5190	Ant1	VN	40	5190.03	5.78035	20	PASS
11N40SISO	5190	Ant1	VN	20	5190.06	11.56069	20	PASS
11N40SISO	5190	Ant1	VN	0	5190.03	5.78035	20	PASS
11N40SISO	5190	Ant1	VN	-10	5190.03	5.78035	20	PASS

11N40SISO	5190	Ant1	VN	-30	5190.03	5.78035	20	PASS
11N40SISO	5190	Ant1	VN	30	5190.06	11.56069	20	PASS
11N40SISO	5190	Ant1	VN	-20	5190.09	17.34104	20	PASS
11N40SISO	5190	Ant2	VN	-20	5190.03	5.78035	20	PASS
11N40SISO	5190	Ant2	VN	40	5190.00	0.00000	20	PASS
11N40SISO	5190	Ant2	VN	30	5190.00	0.00000	20	PASS
11N40SISO	5190	Ant2	VN	20	5190.00	0.00000	20	PASS
11N40SISO	5190	Ant2	VN	10	5189.97	-5.78035	20	PASS
11N40SISO	5190	Ant2	VN	0	5190.00	0.00000	20	PASS
11N40SISO	5190	Ant2	VN	-10	5190.03	5.78035	20	PASS
11N40SISO	5190	Ant2	VN	50	5190.06	11.56069	20	PASS
11N40SISO	5190	Ant2	VN	-30	5190.00	0.00000	20	PASS
11N40SISO	5230	Ant1	VN	40	5230.03	5.73614	20	PASS
11N40SISO	5230	Ant1	VN	-30	5230.03	5.73614	20	PASS
11N40SISO	5230	Ant1	VN	-20	5230.06	11.47228	20	PASS
11N40SISO	5230	Ant1	VN	-10	5230.03	5.73614	20	PASS
11N40SISO	5230	Ant1	VN	0	5230.03	5.73614	20	PASS
11N40SISO	5230	Ant1	VN	10	5230.03	5.73614	20	PASS
11N40SISO	5230	Ant1	VN	50	5230.03	5.73614	20	PASS
11N40SISO	5230	Ant1	VN	20	5230.03	5.73614	20	PASS
11N40SISO	5230	Ant1	VN	30	5230.03	5.73614	20	PASS
11N40SISO	5230	Ant2	VN	-20	5230.00	0.00000	20	PASS
11N40SISO	5230	Ant2	VN	30	5230.03	5.73614	20	PASS
11N40SISO	5230	Ant2	VN	50	5230.03	5.73614	20	PASS
11N40SISO	5230	Ant2	VN	40	5230.03	5.73614	20	PASS
11N40SISO	5230	Ant2	VN	-30	5230.00	0.00000	20	PASS
11N40SISO	5230	Ant2	VN	10	5230.00	0.00000	20	PASS
11N40SISO	5230	Ant2	VN	-10	5229.97	-5.73614	20	PASS
11N40SISO	5230	Ant2	VN	20	5229.97	-5.73614	20	PASS
11N40SISO	5230	Ant2	VN	0	5230.03	5.73614	20	PASS
11N40SISO	5270	Ant1	VN	30	5270.03	5.69260	20	PASS
11N40SISO	5270	Ant1	VN	-30	5270.03	5.69260	20	PASS
11N40SISO	5270	Ant1	VN	-20	5270.06	11.38520	20	PASS
11N40SISO	5270	Ant1	VN	-10	5270.03	5.69260	20	PASS
11N40SISO	5270	Ant1	VN	0	5270.06	11.38520	20	PASS
11N40SISO	5270	Ant1	VN	20	5270.06	11.38520	20	PASS
11N40SISO	5270	Ant1	VN	40	5270.00	0.00000	20	PASS
11N40SISO	5270	Ant1	VN	50	5270.03	5.69260	20	PASS
11N40SISO	5270	Ant1	VN	10	5270.03	5.69260	20	PASS
11N40SISO	5270	Ant2	VN	-30	5270.03	5.69260	20	PASS

11N40SISO	5270	Ant2	VN	50	5270.00	0.00000	20	PASS
11N40SISO	5270	Ant2	VN	30	5270.00	0.00000	20	PASS
11N40SISO	5270	Ant2	VN	40	5270.06	11.38520	20	PASS
11N40SISO	5270	Ant2	VN	10	5270.00	0.00000	20	PASS
11N40SISO	5270	Ant2	VN	0	5270.00	0.00000	20	PASS
11N40SISO	5270	Ant2	VN	-10	5269.97	-5.69260	20	PASS
11N40SISO	5270	Ant2	VN	20	5270.03	5.69260	20	PASS
11N40SISO	5270	Ant2	VN	-20	5270.03	5.69260	20	PASS
11N40SISO	5310	Ant1	VN	10	5310.00	0.00000	20	PASS
11N40SISO	5310	Ant1	VN	-20	5310.06	11.29944	20	PASS
11N40SISO	5310	Ant1	VN	-10	5310.03	5.64972	20	PASS
11N40SISO	5310	Ant1	VN	-30	5310.06	11.29944	20	PASS
11N40SISO	5310	Ant1	VN	0	5310.03	5.64972	20	PASS
11N40SISO	5310	Ant1	VN	20	5310.03	5.64972	20	PASS
11N40SISO	5310	Ant1	VN	30	5310.03	5.64972	20	PASS
11N40SISO	5310	Ant1	VN	40	5310.03	5.64972	20	PASS
11N40SISO	5310	Ant1	VN	50	5310.06	11.29944	20	PASS
11N40SISO	5310	Ant2	VN	40	5310.03	5.64972	20	PASS
11N40SISO	5310	Ant2	VN	-10	5310.03	5.64972	20	PASS
11N40SISO	5310	Ant2	VN	0	5310.06	11.29944	20	PASS
11N40SISO	5310	Ant2	VN	-20	5310.03	5.64972	20	PASS
11N40SISO	5310	Ant2	VN	10	5310.00	0.00000	20	PASS
11N40SISO	5310	Ant2	VN	30	5310.06	11.29944	20	PASS
11N40SISO	5310	Ant2	VN	50	5310.03	5.64972	20	PASS
11N40SISO	5310	Ant2	VN	-30	5310.06	11.29944	20	PASS
11N40SISO	5310	Ant2	VN	20	5310.03	5.64972	20	PASS
11N40SISO	5510	Ant1	VN	50	5510.03	5.44465	20	PASS
11N40SISO	5510	Ant1	VN	-10	5510.00	0.00000	20	PASS
11N40SISO	5510	Ant1	VN	0	5510.00	0.00000	20	PASS
11N40SISO	5510	Ant1	VN	-20	5510.00	0.00000	20	PASS
11N40SISO	5510	Ant1	VN	10	5510.03	5.44465	20	PASS
11N40SISO	5510	Ant1	VN	20	5510.00	0.00000	20	PASS
11N40SISO	5510	Ant1	VN	30	5510.00	0.00000	20	PASS
11N40SISO	5510	Ant1	VN	40	5510.03	5.44465	20	PASS
11N40SISO	5510	Ant1	VN	-30	5510.06	10.88929	20	PASS
11N40SISO	5510	Ant2	VN	-30	5510.03	5.44465	20	PASS
11N40SISO	5510	Ant2	VN	40	5510.06	10.88929	20	PASS
11N40SISO	5510	Ant2	VN	30	5510.06	10.88929	20	PASS
11N40SISO	5510	Ant2	VN	20	5510.03	5.44465	20	PASS
11N40SISO	5510	Ant2	VN	10	5510.00	0.00000	20	PASS

11N40SISO	5510	Ant2	VN	0	5510.03	5.44465	20	PASS
11N40SISO	5510	Ant2	VN	-10	5510.06	10.88929	20	PASS
11N40SISO	5510	Ant2	VN	-20	5510.03	5.44465	20	PASS
11N40SISO	5510	Ant2	VN	50	5510.06	10.88929	20	PASS
11N40SISO	5550	Ant1	VN	50	5550.03	5.40541	20	PASS
11N40SISO	5550	Ant1	VN	40	5550.03	5.40541	20	PASS
11N40SISO	5550	Ant1	VN	30	5550.03	5.40541	20	PASS
11N40SISO	5550	Ant1	VN	20	5550.03	5.40541	20	PASS
11N40SISO	5550	Ant1	VN	10	5550.06	10.81081	20	PASS
11N40SISO	5550	Ant1	VN	0	5550.03	5.40541	20	PASS
11N40SISO	5550	Ant1	VN	-30	5550.03	5.40541	20	PASS
11N40SISO	5550	Ant1	VN	-20	5550.03	5.40541	20	PASS
11N40SISO	5550	Ant1	VN	-10	5550.00	0.00000	20	PASS
11N40SISO	5550	Ant2	VN	-10	5550.03	5.40541	20	PASS
11N40SISO	5550	Ant2	VN	0	5550.03	5.40541	20	PASS
11N40SISO	5550	Ant2	VN	10	5550.00	0.00000	20	PASS
11N40SISO	5550	Ant2	VN	20	5550.00	0.00000	20	PASS
11N40SISO	5550	Ant2	VN	30	5550.03	5.40541	20	PASS
11N40SISO	5550	Ant2	VN	50	5550.03	5.40541	20	PASS
11N40SISO	5550	Ant2	VN	40	5550.03	5.40541	20	PASS
11N40SISO	5550	Ant2	VN	-30	5549.97	-5.40541	20	PASS
11N40SISO	5550	Ant2	VN	-20	5550.00	0.00000	20	PASS
11N40SISO	5670	Ant1	VN	-20	5670.00	0.00000	20	PASS
11N40SISO	5670	Ant1	VN	40	5669.97	-5.29101	20	PASS
11N40SISO	5670	Ant1	VN	30	5670.00	0.00000	20	PASS
11N40SISO	5670	Ant1	VN	20	5669.97	-5.29101	20	PASS
11N40SISO	5670	Ant1	VN	10	5669.97	-5.29101	20	PASS
11N40SISO	5670	Ant1	VN	-10	5669.97	-5.29101	20	PASS
11N40SISO	5670	Ant1	VN	50	5669.97	-5.29101	20	PASS
11N40SISO	5670	Ant1	VN	-30	5670.00	0.00000	20	PASS
11N40SISO	5670	Ant1	VN	0	5670.03	5.29101	20	PASS
11N40SISO	5670	Ant2	VN	10	5670.03	5.29101	20	PASS
11N40SISO	5670	Ant2	VN	-10	5669.97	-5.29101	20	PASS
11N40SISO	5670	Ant2	VN	-20	5670.06	10.58201	20	PASS
11N40SISO	5670	Ant2	VN	0	5670.00	0.00000	20	PASS
11N40SISO	5670	Ant2	VN	20	5670.03	5.29101	20	PASS
11N40SISO	5670	Ant2	VN	30	5669.97	-5.29101	20	PASS
11N40SISO	5670	Ant2	VN	40	5670.00	0.00000	20	PASS
11N40SISO	5670	Ant2	VN	50	5670.00	0.00000	20	PASS
11N40SISO	5670	Ant2	VN	-30	5670.00	0.00000	20	PASS

11N40SISO	5755	Ant1	VN	-20	5755.06	10.42572	20	PASS
11N40SISO	5755	Ant1	VN	-10	5755.12	10.85143	20	PASS
11N40SISO	5755	Ant1	VN	0	5755.06	10.42572	20	PASS
11N40SISO	5755	Ant1	VN	10	5755.09	15.63858	20	PASS
11N40SISO	5755	Ant1	VN	20	5755.09	15.63858	20	PASS
11N40SISO	5755	Ant1	VN	30	5755.12	10.85143	20	PASS
11N40SISO	5755	Ant1	VN	40	5755.09	15.63858	20	PASS
11N40SISO	5755	Ant1	VN	50	5755.06	10.42572	20	PASS
11N40SISO	5755	Ant1	VN	-30	5755.09	15.63858	20	PASS
11N40SISO	5755	Ant2	VN	-10	5755.06	10.42572	20	PASS
11N40SISO	5755	Ant2	VN	50	5755.06	10.42572	20	PASS
11N40SISO	5755	Ant2	VN	40	5755.06	10.42572	20	PASS
11N40SISO	5755	Ant2	VN	30	5755.06	10.42572	20	PASS
11N40SISO	5755	Ant2	VN	20	5755.09	15.63858	20	PASS
11N40SISO	5755	Ant2	VN	0	5755.03	5.21286	20	PASS
11N40SISO	5755	Ant2	VN	-30	5755.06	10.42572	20	PASS
11N40SISO	5755	Ant2	VN	-20	5755.09	15.63858	20	PASS
11N40SISO	5755	Ant2	VN	10	5755.09	15.63858	20	PASS
11N40SISO	5795	Ant1	VN	30	5795.03	5.17688	20	PASS
11N40SISO	5795	Ant1	VN	40	5795.06	10.35375	20	PASS
11N40SISO	5795	Ant1	VN	-20	5795.06	10.35375	20	PASS
11N40SISO	5795	Ant1	VN	20	5795.03	5.17688	20	PASS
11N40SISO	5795	Ant1	VN	10	5795.06	10.35375	20	PASS
11N40SISO	5795	Ant1	VN	0	5795.03	5.17688	20	PASS
11N40SISO	5795	Ant1	VN	-10	5795.00	0.00000	20	PASS
11N40SISO	5795	Ant1	VN	-30	5795.03	5.17688	20	PASS
11N40SISO	5795	Ant1	VN	50	5795.06	10.35375	20	PASS
11N40SISO	5795	Ant2	VN	40	5795.03	5.17688	20	PASS
11N40SISO	5795	Ant2	VN	-20	5795.03	5.17688	20	PASS
11N40SISO	5795	Ant2	VN	-30	5795.06	10.35375	20	PASS
11N40SISO	5795	Ant2	VN	50	5795.03	5.17688	20	PASS
11N40SISO	5795	Ant2	VN	-10	5795.03	5.17688	20	PASS
11N40SISO	5795	Ant2	VN	0	5795.03	5.17688	20	PASS
11N40SISO	5795	Ant2	VN	10	5795.00	0.00000	20	PASS
11N40SISO	5795	Ant2	VN	20	5795.06	10.35375	20	PASS
11N40SISO	5795	Ant2	VN	30	5795.06	10.35375	20	PASS
11AC20SISO	5180	Ant1	VN	30	5180.00	0.00000	20	PASS
11AC20SISO	5180	Ant1	VN	50	5180.00	0.00000	20	PASS
11AC20SISO	5180	Ant1	VN	40	5180.00	0.00000	20	PASS
11AC20SISO	5180	Ant1	VN	20	5179.99	-2.89575	20	PASS

11AC20SISO	5180	Ant1	VN	10	5180.02	2.89575	20	PASS
11AC20SISO	5180	Ant1	VN	0	5179.99	-2.89575	20	PASS
11AC20SISO	5180	Ant1	VN	-10	5179.96	-8.68726	20	PASS
11AC20SISO	5180	Ant1	VN	-20	5179.99	-2.89575	20	PASS
11AC20SISO	5180	Ant1	VN	-30	5180.00	0.00000	20	PASS
11AC20SISO	5180	Ant2	VN	30	5180.03	5.79151	20	PASS
11AC20SISO	5180	Ant2	VN	-30	5180.03	5.79151	20	PASS
11AC20SISO	5180	Ant2	VN	-10	5180.03	5.79151	20	PASS
11AC20SISO	5180	Ant2	VN	0	5179.99	-2.89575	20	PASS
11AC20SISO	5180	Ant2	VN	20	5180.05	8.68726	20	PASS
11AC20SISO	5180	Ant2	VN	40	5180.05	8.68726	20	PASS
11AC20SISO	5180	Ant2	VN	50	5180.02	2.89575	20	PASS
11AC20SISO	5180	Ant2	VN	-20	5180.02	2.89575	20	PASS
11AC20SISO	5180	Ant2	VN	10	5180.02	2.89575	20	PASS
11AC20SISO	5200	Ant1	VN	-10	5199.99	-2.88462	20	PASS
11AC20SISO	5200	Ant1	VN	50	5200.02	2.88462	20	PASS
11AC20SISO	5200	Ant1	VN	30	5199.99	-2.88462	20	PASS
11AC20SISO	5200	Ant1	VN	20	5200.02	2.88462	20	PASS
11AC20SISO	5200	Ant1	VN	10	5200.00	0.00000	20	PASS
11AC20SISO	5200	Ant1	VN	0	5200.00	0.00000	20	PASS
11AC20SISO	5200	Ant1	VN	-20	5200.02	2.88462	20	PASS
11AC20SISO	5200	Ant1	VN	40	5199.99	-2.88462	20	PASS
11AC20SISO	5200	Ant1	VN	-30	5200.00	0.00000	20	PASS
11AC20SISO	5200	Ant2	VN	-20	5200.03	5.76923	20	PASS
11AC20SISO	5200	Ant2	VN	-30	5200.02	2.88462	20	PASS
11AC20SISO	5200	Ant2	VN	40	5200.03	5.76923	20	PASS
11AC20SISO	5200	Ant2	VN	50	5200.00	0.00000	20	PASS
11AC20SISO	5200	Ant2	VN	30	5200.05	8.65385	20	PASS
11AC20SISO	5200	Ant2	VN	-10	5200.00	0.00000	20	PASS
11AC20SISO	5200	Ant2	VN	0	5200.02	2.88462	20	PASS
11AC20SISO	5200	Ant2	VN	10	5200.02	2.88462	20	PASS
11AC20SISO	5200	Ant2	VN	20	5200.03	5.76923	20	PASS
11AC20SISO	5240	Ant1	VN	30	5240.03	5.72519	20	PASS
11AC20SISO	5240	Ant1	VN	40	5240.03	5.72519	20	PASS
11AC20SISO	5240	Ant1	VN	-30	5240.05	8.58779	20	PASS
11AC20SISO	5240	Ant1	VN	-20	5240.02	2.86260	20	PASS
11AC20SISO	5240	Ant1	VN	-10	5240.02	2.86260	20	PASS
11AC20SISO	5240	Ant1	VN	0	5240.02	2.86260	20	PASS
11AC20SISO	5240	Ant1	VN	10	5240.05	8.58779	20	PASS
11AC20SISO	5240	Ant1	VN	20	5240.00	0.00000	20	PASS

11AC20SISO	5240	Ant1	VN	50	5240.06	11.45038	20	PASS
11AC20SISO	5240	Ant2	VN	20	5239.99	-2.86260	20	PASS
11AC20SISO	5240	Ant2	VN	30	5240.03	5.72519	20	PASS
11AC20SISO	5240	Ant2	VN	-30	5240.00	0.00000	20	PASS
11AC20SISO	5240	Ant2	VN	40	5240.02	2.86260	20	PASS
11AC20SISO	5240	Ant2	VN	-20	5240.03	5.72519	20	PASS
11AC20SISO	5240	Ant2	VN	-10	5240.03	5.72519	20	PASS
11AC20SISO	5240	Ant2	VN	10	5240.02	2.86260	20	PASS
11AC20SISO	5240	Ant2	VN	50	5240.05	8.58779	20	PASS
11AC20SISO	5240	Ant2	VN	0	5240.02	2.86260	20	PASS
11AC20SISO	5260	Ant1	VN	-30	5259.99	-2.85171	20	PASS
11AC20SISO	5260	Ant1	VN	-20	5259.99	-2.85171	20	PASS
11AC20SISO	5260	Ant1	VN	-10	5259.97	-5.70342	20	PASS
11AC20SISO	5260	Ant1	VN	0	5260.00	0.00000	20	PASS
11AC20SISO	5260	Ant1	VN	10	5260.00	0.00000	20	PASS
11AC20SISO	5260	Ant1	VN	30	5260.02	2.85171	20	PASS
11AC20SISO	5260	Ant1	VN	40	5259.99	-2.85171	20	PASS
11AC20SISO	5260	Ant1	VN	50	5260.05	8.55513	20	PASS
11AC20SISO	5260	Ant1	VN	20	5260.00	0.00000	20	PASS
11AC20SISO	5260	Ant2	VN	30	5260.00	0.00000	20	PASS
11AC20SISO	5260	Ant2	VN	20	5260.03	5.70342	20	PASS
11AC20SISO	5260	Ant2	VN	10	5260.03	5.70342	20	PASS
11AC20SISO	5260	Ant2	VN	0	5260.00	0.00000	20	PASS
11AC20SISO	5260	Ant2	VN	-10	5260.00	0.00000	20	PASS
11AC20SISO	5260	Ant2	VN	-20	5260.03	5.70342	20	PASS
11AC20SISO	5260	Ant2	VN	50	5259.99	-2.85171	20	PASS
11AC20SISO	5260	Ant2	VN	-30	5260.03	5.70342	20	PASS
11AC20SISO	5260	Ant2	VN	40	5260.00	0.00000	20	PASS
11AC20SISO	5280	Ant1	VN	50	5280.03	5.68182	20	PASS
11AC20SISO	5280	Ant1	VN	-20	5280.03	5.68182	20	PASS
11AC20SISO	5280	Ant1	VN	-10	5280.03	5.68182	20	PASS
11AC20SISO	5280	Ant1	VN	0	5280.00	0.00000	20	PASS
11AC20SISO	5280	Ant1	VN	10	5280.02	2.84091	20	PASS
11AC20SISO	5280	Ant1	VN	20	5280.00	0.00000	20	PASS
11AC20SISO	5280	Ant1	VN	40	5280.02	2.84091	20	PASS
11AC20SISO	5280	Ant1	VN	-30	5280.02	2.84091	20	PASS
11AC20SISO	5280	Ant1	VN	30	5280.02	2.84091	20	PASS
11AC20SISO	5280	Ant2	VN	-30	5280.03	5.68182	20	PASS
11AC20SISO	5280	Ant2	VN	40	5280.00	0.00000	20	PASS
11AC20SISO	5280	Ant2	VN	30	5280.02	2.84091	20	PASS

11AC20SISO	5280	Ant2	VN	20	5280.05	8.52273	20	PASS
11AC20SISO	5280	Ant2	VN	10	5280.00	0.00000	20	PASS
11AC20SISO	5280	Ant2	VN	0	5280.02	2.84091	20	PASS
11AC20SISO	5280	Ant2	VN	-10	5280.00	0.00000	20	PASS
11AC20SISO	5280	Ant2	VN	-20	5280.00	0.00000	20	PASS
11AC20SISO	5280	Ant2	VN	50	5279.99	-2.84091	20	PASS
11AC20SISO	5320	Ant1	VN	40	5320.02	2.81955	20	PASS
11AC20SISO	5320	Ant1	VN	30	5320.02	2.81955	20	PASS
11AC20SISO	5320	Ant1	VN	20	5320.02	2.81955	20	PASS
11AC20SISO	5320	Ant1	VN	10	5320.02	2.81955	20	PASS
11AC20SISO	5320	Ant1	VN	0	5320.02	2.81955	20	PASS
11AC20SISO	5320	Ant1	VN	-10	5320.03	5.63910	20	PASS
11AC20SISO	5320	Ant1	VN	-20	5320.05	8.45865	20	PASS
11AC20SISO	5320	Ant1	VN	50	5320.00	0.00000	20	PASS
11AC20SISO	5320	Ant1	VN	-30	5320.02	2.81955	20	PASS
11AC20SISO	5320	Ant2	VN	-10	5320.02	2.81955	20	PASS
11AC20SISO	5320	Ant2	VN	0	5320.03	5.63910	20	PASS
11AC20SISO	5320	Ant2	VN	50	5320.06	11.27820	20	PASS
11AC20SISO	5320	Ant2	VN	-30	5320.03	5.63910	20	PASS
11AC20SISO	5320	Ant2	VN	10	5320.06	11.27820	20	PASS
11AC20SISO	5320	Ant2	VN	40	5320.05	8.45865	20	PASS
11AC20SISO	5320	Ant2	VN	20	5320.03	5.63910	20	PASS
11AC20SISO	5320	Ant2	VN	30	5320.03	5.63910	20	PASS
11AC20SISO	5320	Ant2	VN	-20	5320.05	8.45865	20	PASS
11AC20SISO	5500	Ant1	VN	-10	5500.03	5.45455	20	PASS
11AC20SISO	5500	Ant1	VN	-20	5500.02	2.72727	20	PASS
11AC20SISO	5500	Ant1	VN	40	5500.05	8.18182	20	PASS
11AC20SISO	5500	Ant1	VN	0	5500.02	2.72727	20	PASS
11AC20SISO	5500	Ant1	VN	10	5500.03	5.45455	20	PASS
11AC20SISO	5500	Ant1	VN	-30	5500.02	2.72727	20	PASS
11AC20SISO	5500	Ant1	VN	20	5500.03	5.45455	20	PASS
11AC20SISO	5500	Ant1	VN	30	5499.99	-2.72727	20	PASS
11AC20SISO	5500	Ant1	VN	50	5500.03	5.45455	20	PASS
11AC20SISO	5500	Ant2	VN	40	5500.05	8.18182	20	PASS
11AC20SISO	5500	Ant2	VN	50	5500.06	10.90909	20	PASS
11AC20SISO	5500	Ant2	VN	30	5500.03	5.45455	20	PASS
11AC20SISO	5500	Ant2	VN	20	5500.03	5.45455	20	PASS
11AC20SISO	5500	Ant2	VN	10	5500.06	10.90909	20	PASS
11AC20SISO	5500	Ant2	VN	0	5500.02	2.72727	20	PASS
11AC20SISO	5500	Ant2	VN	-10	5500.03	5.45455	20	PASS

11AC20SISO	5500	Ant2	VN	-20	5500.06	10.90909	20	PASS
11AC20SISO	5500	Ant2	VN	-30	5500.03	5.45455	20	PASS
11AC20SISO	5580	Ant1	VN	-30	5580.00	0.00000	20	PASS
11AC20SISO	5580	Ant1	VN	20	5579.96	-8.06452	20	PASS
11AC20SISO	5580	Ant1	VN	10	5579.99	-2.68817	20	PASS
11AC20SISO	5580	Ant1	VN	0	5580.02	2.68817	20	PASS
11AC20SISO	5580	Ant1	VN	40	5579.99	-2.68817	20	PASS
11AC20SISO	5580	Ant1	VN	-10	5580.00	0.00000	20	PASS
11AC20SISO	5580	Ant1	VN	-20	5579.99	-2.68817	20	PASS
11AC20SISO	5580	Ant1	VN	50	5579.99	-2.68817	20	PASS
11AC20SISO	5580	Ant1	VN	30	5579.97	-5.37634	20	PASS
11AC20SISO	5580	Ant2	VN	-30	5580.02	2.68817	20	PASS
11AC20SISO	5580	Ant2	VN	30	5580.03	5.37634	20	PASS
11AC20SISO	5580	Ant2	VN	20	5580.02	2.68817	20	PASS
11AC20SISO	5580	Ant2	VN	40	5579.99	-2.68817	20	PASS
11AC20SISO	5580	Ant2	VN	-20	5579.99	-2.68817	20	PASS
11AC20SISO	5580	Ant2	VN	10	5580.05	8.06452	20	PASS
11AC20SISO	5580	Ant2	VN	50	5580.00	0.00000	20	PASS
11AC20SISO	5580	Ant2	VN	0	5580.02	2.68817	20	PASS
11AC20SISO	5580	Ant2	VN	-10	5580.00	0.00000	20	PASS
11AC20SISO	5700	Ant1	VN	-30	5700.08	13.15790	20	PASS
11AC20SISO	5700	Ant1	VN	-20	5700.06	10.52632	20	PASS
11AC20SISO	5700	Ant1	VN	-10	5700.09	15.78947	20	PASS
11AC20SISO	5700	Ant1	VN	0	5700.08	13.15790	20	PASS
11AC20SISO	5700	Ant1	VN	10	5700.09	15.78947	20	PASS
11AC20SISO	5700	Ant1	VN	20	5700.03	5.26316	20	PASS
11AC20SISO	5700	Ant1	VN	30	5700.08	13.15790	20	PASS
11AC20SISO	5700	Ant1	VN	40	5700.14	13.68421	20	PASS
11AC20SISO	5700	Ant1	VN	50	5700.09	15.78947	20	PASS
11AC20SISO	5700	Ant2	VN	40	5700.06	10.52632	20	PASS
11AC20SISO	5700	Ant2	VN	30	5700.06	10.52632	20	PASS
11AC20SISO	5700	Ant2	VN	20	5700.06	10.52632	20	PASS
11AC20SISO	5700	Ant2	VN	10	5700.06	10.52632	20	PASS
11AC20SISO	5700	Ant2	VN	-10	5700.06	10.52632	20	PASS
11AC20SISO	5700	Ant2	VN	-20	5700.05	7.89474	20	PASS
11AC20SISO	5700	Ant2	VN	-30	5700.06	10.52632	20	PASS
11AC20SISO	5700	Ant2	VN	50	5700.06	10.52632	20	PASS
11AC20SISO	5700	Ant2	VN	0	5700.05	7.89474	20	PASS
11AC20SISO	5745	Ant1	VN	20	5745.12	10.88773	20	PASS
11AC20SISO	5745	Ant1	VN	-20	5745.08	13.05483	20	PASS

11AC20SISO	5745	Ant1	VN	-30	5745.11	18.27676	20	PASS
11AC20SISO	5745	Ant1	VN	-10	5745.09	15.66580	20	PASS
11AC20SISO	5745	Ant1	VN	10	5745.09	15.66580	20	PASS
11AC20SISO	5745	Ant1	VN	30	5745.08	13.05483	20	PASS
11AC20SISO	5745	Ant1	VN	50	5745.12	10.88773	20	PASS
11AC20SISO	5745	Ant1	VN	40	5745.11	18.27676	20	PASS
11AC20SISO	5745	Ant1	VN	0	5745.09	15.66580	20	PASS
11AC20SISO	5745	Ant2	VN	10	5745.05	7.83290	20	PASS
11AC20SISO	5745	Ant2	VN	40	5745.06	10.44386	20	PASS
11AC20SISO	5745	Ant2	VN	20	5745.05	7.83290	20	PASS
11AC20SISO	5745	Ant2	VN	0	5745.05	7.83290	20	PASS
11AC20SISO	5745	Ant2	VN	-10	5745.03	5.22193	20	PASS
11AC20SISO	5745	Ant2	VN	-20	5745.05	7.83290	20	PASS
11AC20SISO	5745	Ant2	VN	50	5745.03	5.22193	20	PASS
11AC20SISO	5745	Ant2	VN	-30	5745.05	7.83290	20	PASS
11AC20SISO	5745	Ant2	VN	30	5745.05	7.83290	20	PASS
11AC20SISO	5785	Ant1	VN	20	5785.02	2.59291	20	PASS
11AC20SISO	5785	Ant1	VN	30	5784.99	-2.59291	20	PASS
11AC20SISO	5785	Ant1	VN	10	5785.02	2.59291	20	PASS
11AC20SISO	5785	Ant1	VN	0	5785.03	5.18583	20	PASS
11AC20SISO	5785	Ant1	VN	-10	5785.03	5.18583	20	PASS
11AC20SISO	5785	Ant1	VN	-20	5785.00	0.00000	20	PASS
11AC20SISO	5785	Ant1	VN	-30	5785.03	5.18583	20	PASS
11AC20SISO	5785	Ant1	VN	50	5785.02	2.59291	20	PASS
11AC20SISO	5785	Ant1	VN	40	5785.05	7.77874	20	PASS
11AC20SISO	5785	Ant2	VN	0	5785.02	2.59291	20	PASS
11AC20SISO	5785	Ant2	VN	-30	5785.05	7.77874	20	PASS
11AC20SISO	5785	Ant2	VN	50	5785.06	10.37165	20	PASS
11AC20SISO	5785	Ant2	VN	40	5785.05	7.77874	20	PASS
11AC20SISO	5785	Ant2	VN	30	5785.06	10.37165	20	PASS
11AC20SISO	5785	Ant2	VN	10	5785.06	10.37165	20	PASS
11AC20SISO	5785	Ant2	VN	-10	5785.03	5.18583	20	PASS
11AC20SISO	5785	Ant2	VN	-20	5785.03	5.18583	20	PASS
11AC20SISO	5785	Ant2	VN	20	5785.03	5.18583	20	PASS
11AC20SISO	5825	Ant1	VN	-30	5825.05	7.72532	20	PASS
11AC20SISO	5825	Ant1	VN	-20	5825.06	10.30043	20	PASS
11AC20SISO	5825	Ant1	VN	-10	5825.05	7.72532	20	PASS
11AC20SISO	5825	Ant1	VN	0	5825.06	10.30043	20	PASS
11AC20SISO	5825	Ant1	VN	10	5825.06	10.30043	20	PASS
11AC20SISO	5825	Ant1	VN	20	5825.06	10.30043	20	PASS

11AC20SISO	5825	Ant1	VN	30	5825.06	10.30043	20	PASS
11AC20SISO	5825	Ant1	VN	50	5825.08	12.87554	20	PASS
11AC20SISO	5825	Ant1	VN	40	5825.05	7.72532	20	PASS
11AC20SISO	5825	Ant2	VN	20	5825.03	5.15022	20	PASS
11AC20SISO	5825	Ant2	VN	-20	5825.03	5.15022	20	PASS
11AC20SISO	5825	Ant2	VN	40	5825.03	5.15022	20	PASS
11AC20SISO	5825	Ant2	VN	-10	5825.03	5.15022	20	PASS
11AC20SISO	5825	Ant2	VN	10	5825.02	2.57511	20	PASS
11AC20SISO	5825	Ant2	VN	50	5825.05	7.72532	20	PASS
11AC20SISO	5825	Ant2	VN	30	5825.05	7.72532	20	PASS
11AC20SISO	5825	Ant2	VN	-30	5825.06	10.30043	20	PASS
11AC20SISO	5825	Ant2	VN	0	5825.02	2.57511	20	PASS
11AC40SISO	5190	Ant1	VN	30	5189.94	-11.56069	20	PASS
11AC40SISO	5190	Ant1	VN	50	5189.97	-5.78035	20	PASS
11AC40SISO	5190	Ant1	VN	-30	5189.94	-11.56069	20	PASS
11AC40SISO	5190	Ant1	VN	-20	5190.00	0.00000	20	PASS
11AC40SISO	5190	Ant1	VN	-10	5189.94	-11.56069	20	PASS
11AC40SISO	5190	Ant1	VN	0	5189.94	-11.56069	20	PASS
11AC40SISO	5190	Ant1	VN	10	5189.97	-5.78035	20	PASS
11AC40SISO	5190	Ant1	VN	20	5189.97	-5.78035	20	PASS
11AC40SISO	5190	Ant1	VN	40	5189.94	-11.56069	20	PASS
11AC40SISO	5190	Ant2	VN	30	5190.06	11.56069	20	PASS
11AC40SISO	5190	Ant2	VN	-30	5190.00	0.00000	20	PASS
11AC40SISO	5190	Ant2	VN	-20	5190.06	11.56069	20	PASS
11AC40SISO	5190	Ant2	VN	-10	5190.03	5.78035	20	PASS
11AC40SISO	5190	Ant2	VN	0	5190.03	5.78035	20	PASS
11AC40SISO	5190	Ant2	VN	10	5190.03	5.78035	20	PASS
11AC40SISO	5190	Ant2	VN	20	5190.03	5.78035	20	PASS
11AC40SISO	5190	Ant2	VN	40	5190.03	5.78035	20	PASS
11AC40SISO	5190	Ant2	VN	50	5190.03	5.78035	20	PASS
11AC40SISO	5230	Ant1	VN	10	5229.97	-5.73614	20	PASS
11AC40SISO	5230	Ant1	VN	-30	5229.97	-5.73614	20	PASS
11AC40SISO	5230	Ant1	VN	-20	5230.00	0.00000	20	PASS
11AC40SISO	5230	Ant1	VN	0	5229.97	-5.73614	20	PASS
11AC40SISO	5230	Ant1	VN	20	5229.97	-5.73614	20	PASS
11AC40SISO	5230	Ant1	VN	30	5230.00	0.00000	20	PASS
11AC40SISO	5230	Ant1	VN	40	5229.97	-5.73614	20	PASS
11AC40SISO	5230	Ant1	VN	50	5229.94	-11.47228	20	PASS
11AC40SISO	5230	Ant1	VN	-10	5229.97	-5.73614	20	PASS
11AC40SISO	5230	Ant2	VN	-10	5230.03	5.73614	20	PASS

11AC40SISO	5230	Ant2	VN	40	5230.03	5.73614	20	PASS
11AC40SISO	5230	Ant2	VN	-30	5230.00	0.00000	20	PASS
11AC40SISO	5230	Ant2	VN	-20	5230.03	5.73614	20	PASS
11AC40SISO	5230	Ant2	VN	50	5230.00	0.00000	20	PASS
11AC40SISO	5230	Ant2	VN	20	5230.00	0.00000	20	PASS
11AC40SISO	5230	Ant2	VN	10	5230.00	0.00000	20	PASS
11AC40SISO	5230	Ant2	VN	0	5230.00	0.00000	20	PASS
11AC40SISO	5230	Ant2	VN	30	5230.06	11.47228	20	PASS
11AC40SISO	5270	Ant1	VN	50	5269.97	-5.69260	20	PASS
11AC40SISO	5270	Ant1	VN	30	5270.00	0.00000	20	PASS
11AC40SISO	5270	Ant1	VN	20	5269.97	-5.69260	20	PASS
11AC40SISO	5270	Ant1	VN	10	5269.97	-5.69260	20	PASS
11AC40SISO	5270	Ant1	VN	0	5269.97	-5.69260	20	PASS
11AC40SISO	5270	Ant1	VN	-10	5269.97	-5.69260	20	PASS
11AC40SISO	5270	Ant1	VN	40	5269.97	-5.69260	20	PASS
11AC40SISO	5270	Ant1	VN	-20	5269.97	-5.69260	20	PASS
11AC40SISO	5270	Ant1	VN	-30	5269.94	-11.38520	20	PASS
11AC40SISO	5270	Ant2	VN	50	5270.00	0.00000	20	PASS
11AC40SISO	5270	Ant2	VN	20	5270.03	5.69260	20	PASS
11AC40SISO	5270	Ant2	VN	10	5270.03	5.69260	20	PASS
11AC40SISO	5270	Ant2	VN	0	5270.03	5.69260	20	PASS
11AC40SISO	5270	Ant2	VN	-10	5270.00	0.00000	20	PASS
11AC40SISO	5270	Ant2	VN	-20	5270.06	11.38520	20	PASS
11AC40SISO	5270	Ant2	VN	-30	5270.00	0.00000	20	PASS
11AC40SISO	5270	Ant2	VN	40	5270.00	0.00000	20	PASS
11AC40SISO	5270	Ant2	VN	30	5269.97	-5.69260	20	PASS
11AC40SISO	5310	Ant1	VN	-30	5310.00	0.00000	20	PASS
11AC40SISO	5310	Ant1	VN	30	5309.97	-5.64972	20	PASS
11AC40SISO	5310	Ant1	VN	20	5310.00	0.00000	20	PASS
11AC40SISO	5310	Ant1	VN	10	5310.00	0.00000	20	PASS
11AC40SISO	5310	Ant1	VN	50	5310.00	0.00000	20	PASS
11AC40SISO	5310	Ant1	VN	0	5310.00	0.00000	20	PASS
11AC40SISO	5310	Ant1	VN	-10	5310.00	0.00000	20	PASS
11AC40SISO	5310	Ant1	VN	-20	5310.00	0.00000	20	PASS
11AC40SISO	5310	Ant1	VN	40	5310.00	0.00000	20	PASS
11AC40SISO	5310	Ant2	VN	40	5310.06	11.29944	20	PASS
11AC40SISO	5310	Ant2	VN	10	5310.03	5.64972	20	PASS
11AC40SISO	5310	Ant2	VN	30	5310.03	5.64972	20	PASS
11AC40SISO	5310	Ant2	VN	20	5310.06	11.29944	20	PASS
11AC40SISO	5310	Ant2	VN	0	5310.03	5.64972	20	PASS

11AC40SISO	5310	Ant2	VN	-20	5310.00	0.00000	20	PASS
11AC40SISO	5310	Ant2	VN	-30	5310.06	11.29944	20	PASS
11AC40SISO	5310	Ant2	VN	50	5310.03	5.64972	20	PASS
11AC40SISO	5310	Ant2	VN	-10	5310.03	5.64972	20	PASS
11AC40SISO	5510	Ant1	VN	20	5509.97	-5.44465	20	PASS
11AC40SISO	5510	Ant1	VN	-20	5510.00	0.00000	20	PASS
11AC40SISO	5510	Ant1	VN	-10	5510.00	0.00000	20	PASS
11AC40SISO	5510	Ant1	VN	0	5510.00	0.00000	20	PASS
11AC40SISO	5510	Ant1	VN	-30	5510.00	0.00000	20	PASS
11AC40SISO	5510	Ant1	VN	10	5510.00	0.00000	20	PASS
11AC40SISO	5510	Ant1	VN	50	5510.00	0.00000	20	PASS
11AC40SISO	5510	Ant1	VN	30	5510.00	0.00000	20	PASS
11AC40SISO	5510	Ant1	VN	40	5510.00	0.00000	20	PASS
11AC40SISO	5510	Ant2	VN	30	5510.00	0.00000	20	PASS
11AC40SISO	5510	Ant2	VN	20	5510.03	5.44465	20	PASS
11AC40SISO	5510	Ant2	VN	10	5510.03	5.44465	20	PASS
11AC40SISO	5510	Ant2	VN	-30	5510.03	5.44465	20	PASS
11AC40SISO	5510	Ant2	VN	0	5510.03	5.44465	20	PASS
11AC40SISO	5510	Ant2	VN	-10	5510.00	0.00000	20	PASS
11AC40SISO	5510	Ant2	VN	-20	5510.03	5.44465	20	PASS
11AC40SISO	5510	Ant2	VN	40	5510.03	5.44465	20	PASS
11AC40SISO	5510	Ant2	VN	50	5510.03	5.44465	20	PASS
11AC40SISO	5550	Ant1	VN	0	5549.97	-5.40541	20	PASS
11AC40SISO	5550	Ant1	VN	40	5550.00	0.00000	20	PASS
11AC40SISO	5550	Ant1	VN	30	5550.00	0.00000	20	PASS
11AC40SISO	5550	Ant1	VN	10	5549.97	-5.40541	20	PASS
11AC40SISO	5550	Ant1	VN	-10	5549.97	-5.40541	20	PASS
11AC40SISO	5550	Ant1	VN	-20	5550.00	0.00000	20	PASS
11AC40SISO	5550	Ant1	VN	-30	5549.97	-5.40541	20	PASS
11AC40SISO	5550	Ant1	VN	50	5550.00	0.00000	20	PASS
11AC40SISO	5550	Ant1	VN	20	5550.00	0.00000	20	PASS
11AC40SISO	5550	Ant2	VN	-10	5550.00	0.00000	20	PASS
11AC40SISO	5550	Ant2	VN	0	5550.00	0.00000	20	PASS
11AC40SISO	5550	Ant2	VN	10	5550.00	0.00000	20	PASS
11AC40SISO	5550	Ant2	VN	20	5550.00	0.00000	20	PASS
11AC40SISO	5550	Ant2	VN	30	5550.03	5.40541	20	PASS
11AC40SISO	5550	Ant2	VN	40	5550.00	0.00000	20	PASS
11AC40SISO	5550	Ant2	VN	-30	5549.97	-5.40541	20	PASS
11AC40SISO	5550	Ant2	VN	-20	5550.03	5.40541	20	PASS
11AC40SISO	5550	Ant2	VN	50	5550.00	0.00000	20	PASS

11AC40SISO	5670	Ant1	VN	50	5669.94	-10.58201	20	PASS
11AC40SISO	5670	Ant1	VN	-20	5669.94	-10.58201	20	PASS
11AC40SISO	5670	Ant1	VN	-10	5669.97	-5.29101	20	PASS
11AC40SISO	5670	Ant1	VN	0	5669.94	-10.58201	20	PASS
11AC40SISO	5670	Ant1	VN	10	5669.94	-10.58201	20	PASS
11AC40SISO	5670	Ant1	VN	20	5669.94	-10.58201	20	PASS
11AC40SISO	5670	Ant1	VN	40	5669.94	-10.58201	20	PASS
11AC40SISO	5670	Ant1	VN	-30	5669.97	-5.29101	20	PASS
11AC40SISO	5670	Ant1	VN	30	5669.94	-10.58201	20	PASS
11AC40SISO	5670	Ant2	VN	50	5670.03	5.29101	20	PASS
11AC40SISO	5670	Ant2	VN	40	5670.03	5.29101	20	PASS
11AC40SISO	5670	Ant2	VN	30	5670.00	0.00000	20	PASS
11AC40SISO	5670	Ant2	VN	20	5669.97	-5.29101	20	PASS
11AC40SISO	5670	Ant2	VN	10	5670.00	0.00000	20	PASS
11AC40SISO	5670	Ant2	VN	0	5670.00	0.00000	20	PASS
11AC40SISO	5670	Ant2	VN	-10	5670.03	5.29101	20	PASS
11AC40SISO	5670	Ant2	VN	-30	5670.03	5.29101	20	PASS
11AC40SISO	5670	Ant2	VN	-20	5670.03	5.29101	20	PASS
11AC40SISO	5755	Ant1	VN	-30	5755.03	5.21286	20	PASS
11AC40SISO	5755	Ant1	VN	-20	5755.06	10.42572	20	PASS
11AC40SISO	5755	Ant1	VN	-10	5755.03	5.21286	20	PASS
11AC40SISO	5755	Ant1	VN	0	5755.06	10.42572	20	PASS
11AC40SISO	5755	Ant1	VN	10	5755.06	10.42572	20	PASS
11AC40SISO	5755	Ant1	VN	20	5755.06	10.42572	20	PASS
11AC40SISO	5755	Ant1	VN	30	5755.06	10.42572	20	PASS
11AC40SISO	5755	Ant1	VN	50	5755.06	10.42572	20	PASS
11AC40SISO	5755	Ant1	VN	40	5755.06	10.42572	20	PASS
11AC40SISO	5755	Ant2	VN	-30	5755.06	10.42572	20	PASS
11AC40SISO	5755	Ant2	VN	40	5755.06	10.42572	20	PASS
11AC40SISO	5755	Ant2	VN	50	5755.06	10.42572	20	PASS
11AC40SISO	5755	Ant2	VN	30	5755.09	15.63858	20	PASS
11AC40SISO	5755	Ant2	VN	20	5755.03	5.21286	20	PASS
11AC40SISO	5755	Ant2	VN	10	5755.06	10.42572	20	PASS
11AC40SISO	5755	Ant2	VN	0	5755.06	10.42572	20	PASS
11AC40SISO	5755	Ant2	VN	-20	5755.06	10.42572	20	PASS
11AC40SISO	5755	Ant2	VN	-10	5755.03	5.21286	20	PASS
11AC40SISO	5795	Ant1	VN	50	5795.03	5.17688	20	PASS
11AC40SISO	5795	Ant1	VN	40	5795.06	10.35375	20	PASS
11AC40SISO	5795	Ant1	VN	30	5795.06	10.35375	20	PASS
11AC40SISO	5795	Ant1	VN	20	5795.03	5.17688	20	PASS

11AC40SISO	5795	Ant1	VN	10	5795.06	10.35375	20	PASS
11AC40SISO	5795	Ant1	VN	0	5795.06	10.35375	20	PASS
11AC40SISO	5795	Ant1	VN	-10	5795.03	5.17688	20	PASS
11AC40SISO	5795	Ant1	VN	-30	5795.09	15.53063	20	PASS
11AC40SISO	5795	Ant1	VN	-20	5795.06	10.35375	20	PASS
11AC40SISO	5795	Ant2	VN	-30	5795.03	5.17688	20	PASS
11AC40SISO	5795	Ant2	VN	-10	5795.06	10.35375	20	PASS
11AC40SISO	5795	Ant2	VN	30	5795.03	5.17688	20	PASS
11AC40SISO	5795	Ant2	VN	50	5795.06	10.35375	20	PASS
11AC40SISO	5795	Ant2	VN	40	5795.06	10.35375	20	PASS
11AC40SISO	5795	Ant2	VN	0	5795.06	10.35375	20	PASS
11AC40SISO	5795	Ant2	VN	-20	5795.06	10.35375	20	PASS
11AC40SISO	5795	Ant2	VN	20	5795.06	10.35375	20	PASS
11AC40SISO	5795	Ant2	VN	10	5795.03	5.17688	20	PASS
11AC80SISO	5210	Ant1	VN	30	5210.00	0.00000	20	PASS
11AC80SISO	5210	Ant1	VN	-30	5210.06	11.51632	20	PASS
11AC80SISO	5210	Ant1	VN	-20	5210.00	0.00000	20	PASS
11AC80SISO	5210	Ant1	VN	-10	5210.06	11.51632	20	PASS
11AC80SISO	5210	Ant1	VN	0	5210.06	11.51632	20	PASS
11AC80SISO	5210	Ant1	VN	20	5210.06	11.51632	20	PASS
11AC80SISO	5210	Ant1	VN	40	5210.06	11.51632	20	PASS
11AC80SISO	5210	Ant1	VN	50	5210.06	11.51632	20	PASS
11AC80SISO	5210	Ant1	VN	10	5210.06	11.51632	20	PASS
11AC80SISO	5210	Ant2	VN	-20	5210.06	11.51632	20	PASS
11AC80SISO	5210	Ant2	VN	-30	5210.06	11.51632	20	PASS
11AC80SISO	5210	Ant2	VN	0	5210.06	11.51632	20	PASS
11AC80SISO	5210	Ant2	VN	-10	5210.06	11.51632	20	PASS
11AC80SISO	5210	Ant2	VN	10	5210.12	13.03263	20	PASS
11AC80SISO	5210	Ant2	VN	20	5210.06	11.51632	20	PASS
11AC80SISO	5210	Ant2	VN	30	5210.06	11.51632	20	PASS
11AC80SISO	5210	Ant2	VN	50	5210.00	0.00000	20	PASS
11AC80SISO	5210	Ant2	VN	40	5210.06	11.51632	20	PASS
11AC80SISO	5290	Ant1	VN	40	5290.00	0.00000	20	PASS
11AC80SISO	5290	Ant1	VN	30	5290.00	0.00000	20	PASS
11AC80SISO	5290	Ant1	VN	20	5290.00	0.00000	20	PASS
11AC80SISO	5290	Ant1	VN	10	5290.00	0.00000	20	PASS
11AC80SISO	5290	Ant1	VN	0	5290.00	0.00000	20	PASS
11AC80SISO	5290	Ant1	VN	-10	5290.00	0.00000	20	PASS
11AC80SISO	5290	Ant1	VN	-20	5290.00	0.00000	20	PASS
11AC80SISO	5290	Ant1	VN	-30	5290.00	0.00000	20	PASS

11AC80SISO	5290	Ant1	VN	50	5290.00	0.00000	20	PASS
11AC80SISO	5290	Ant2	VN	-10	5290.00	0.00000	20	PASS
11AC80SISO	5290	Ant2	VN	0	5290.00	0.00000	20	PASS
11AC80SISO	5290	Ant2	VN	50	5290.06	11.34216	20	PASS
11AC80SISO	5290	Ant2	VN	-30	5290.06	11.34216	20	PASS
11AC80SISO	5290	Ant2	VN	10	5290.00	0.00000	20	PASS
11AC80SISO	5290	Ant2	VN	-20	5290.06	11.34216	20	PASS
11AC80SISO	5290	Ant2	VN	20	5290.00	0.00000	20	PASS
11AC80SISO	5290	Ant2	VN	30	5290.06	11.34216	20	PASS
11AC80SISO	5290	Ant2	VN	40	5290.00	0.00000	20	PASS
11AC80SISO	5530	Ant1	VN	-20	5530.00	0.00000	20	PASS
11AC80SISO	5530	Ant1	VN	40	5530.00	0.00000	20	PASS
11AC80SISO	5530	Ant1	VN	30	5529.94	-10.84991	20	PASS
11AC80SISO	5530	Ant1	VN	20	5530.00	0.00000	20	PASS
11AC80SISO	5530	Ant1	VN	-30	5530.00	0.00000	20	PASS
11AC80SISO	5530	Ant1	VN	10	5530.00	0.00000	20	PASS
11AC80SISO	5530	Ant1	VN	0	5530.00	0.00000	20	PASS
11AC80SISO	5530	Ant1	VN	-10	5530.00	0.00000	20	PASS
11AC80SISO	5530	Ant1	VN	50	5529.94	-10.84991	20	PASS
11AC80SISO	5530	Ant2	VN	-30	5529.94	-10.84991	20	PASS
11AC80SISO	5530	Ant2	VN	-20	5530.00	0.00000	20	PASS
11AC80SISO	5530	Ant2	VN	-10	5530.00	0.00000	20	PASS
11AC80SISO	5530	Ant2	VN	0	5530.06	10.84991	20	PASS
11AC80SISO	5530	Ant2	VN	10	5530.06	10.84991	20	PASS
11AC80SISO	5530	Ant2	VN	20	5530.00	0.00000	20	PASS
11AC80SISO	5530	Ant2	VN	50	5530.00	0.00000	20	PASS
11AC80SISO	5530	Ant2	VN	40	5530.06	10.84991	20	PASS
11AC80SISO	5530	Ant2	VN	30	5530.00	0.00000	20	PASS
11AC80SISO	5775	Ant1	VN	-20	5775.12	10.77922	20	PASS
11AC80SISO	5775	Ant1	VN	-10	5775.12	10.77922	20	PASS
11AC80SISO	5775	Ant1	VN	0	5775.06	10.38961	20	PASS
11AC80SISO	5775	Ant1	VN	10	5775.12	10.77922	20	PASS
11AC80SISO	5775	Ant1	VN	20	5775.12	10.77922	20	PASS
11AC80SISO	5775	Ant1	VN	30	5775.18	11.16883	20	PASS
11AC80SISO	5775	Ant1	VN	50	5775.12	10.77922	20	PASS
11AC80SISO	5775	Ant1	VN	-30	5775.06	10.38961	20	PASS
11AC80SISO	5775	Ant1	VN	40	5775.06	10.38961	20	PASS
11AC80SISO	5775	Ant2	VN	50	5775.12	10.77922	20	PASS
11AC80SISO	5775	Ant2	VN	40	5775.18	11.16883	20	PASS
11AC80SISO	5775	Ant2	VN	30	5775.06	10.38961	20	PASS

11AC80SISO	5775	Ant2	VN	20	5775.06	10.38961	20	PASS
11AC80SISO	5775	Ant2	VN	10	5775.18	11.16883	20	PASS
11AC80SISO	5775	Ant2	VN	0	5775.06	10.38961	20	PASS
11AC80SISO	5775	Ant2	VN	-10	5775.06	10.38961	20	PASS
11AC80SISO	5775	Ant2	VN	-30	5775.06	10.38961	20	PASS
11AC80SISO	5775	Ant2	VN	-20	5775.06	10.38961	20	PASS

## 9. Emissions in restricted frequency bands

### 9.1. Block diagram of test setup

In 3m Anechoic Chamber Test Setup Diagram for 9KHz-30MHz

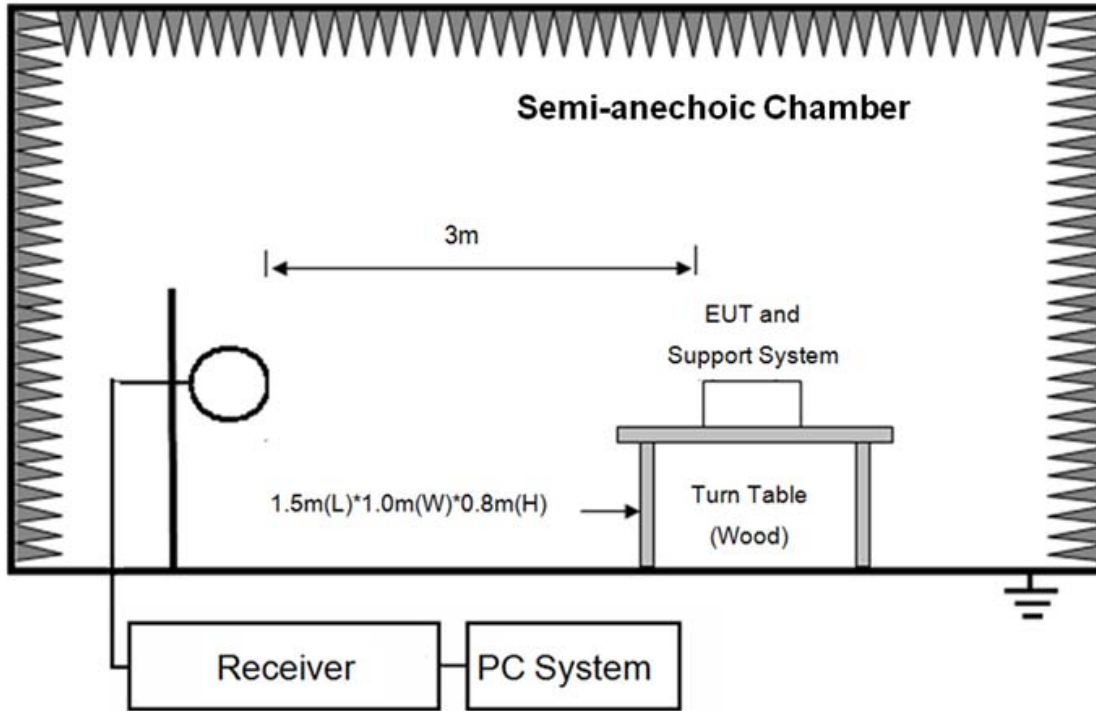

In 3m Anechoic Chamber Test Setup Diagram for 30MHz-1GHz

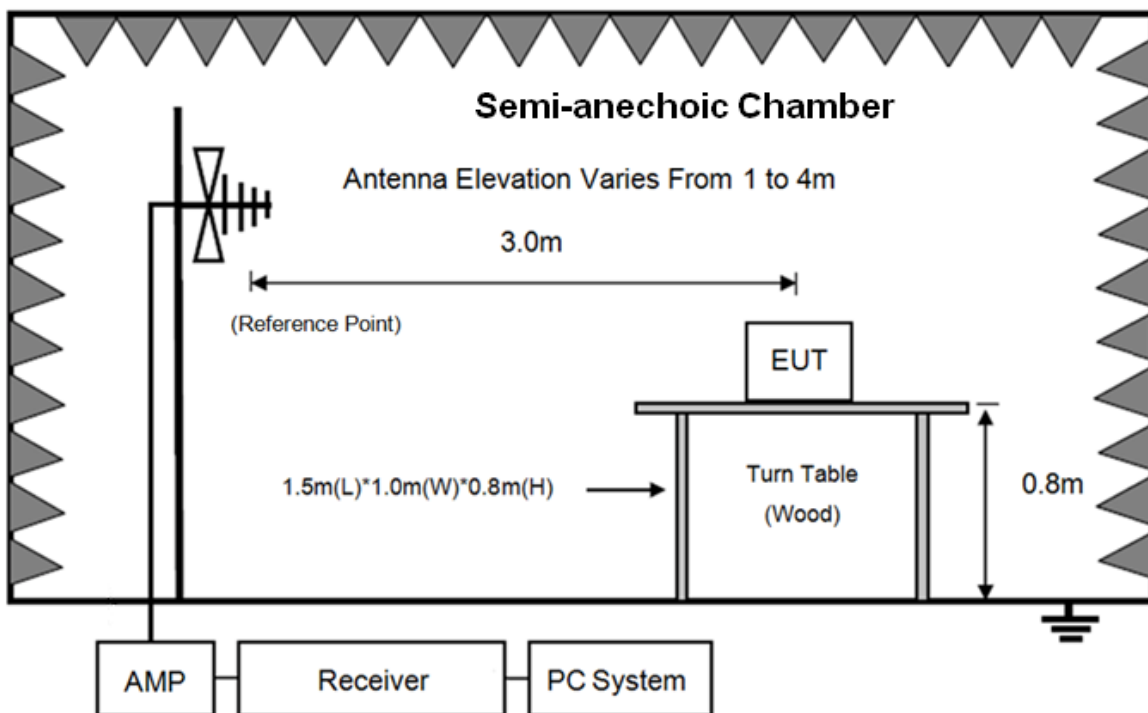

In 3m Anechoic Chamber Test Setup Diagram for frequency above 1GHz

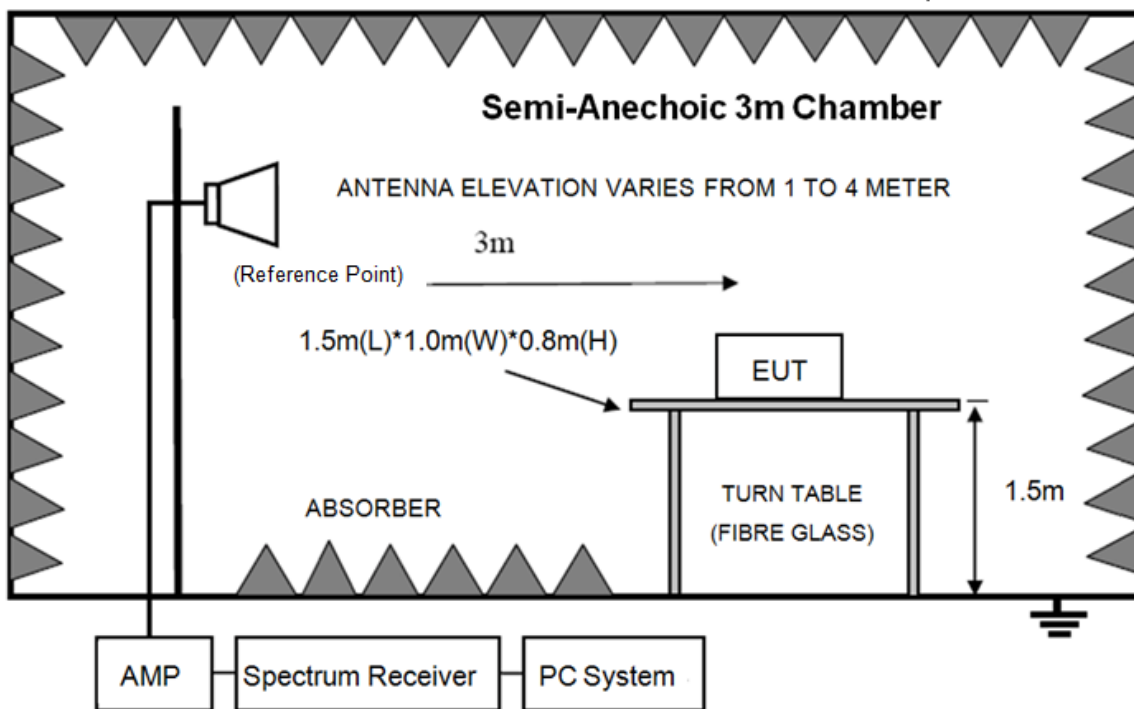

Note: For harmonic emissions test a appropriate high pass filter was inserted in the input port of AMP.

**9.2. Limit**

8.3.1 FCC 15.205 Restricted frequency band

MHz	MHz	MHz	GHz
0.090-0.110	16.42-16.423	399.9-410	4.5-5.15
10.495-0.505	16.69475-16.69525	608-614	5.35-5.46
2.1735-2.1905	16.80425-16.80475	960-1240	7.25-7.75
4.125-4.128	25.5-25.67	1300-1427	8.025-8.5
4.1772&4.17775	37.5-38.25	1435-1626.5	9.0-9.2
4.2072&4.20775	73-74.6	1645.5-1646.5	9.3-9.5
6.215-6.218	74.8-75.2	1660-1710	10.6-12.7
6.26775-6.26825	108-121.94	1718.8-1722.2	13.25-13.4
6.31175-6.31225	123-138	2200-2300	14.47-14.5
8.291-8.294	149.9-150.05	2310-2390	15.35-16.2
8.362-8.366	156.52475-156.52525	2483.5-2500	17.7-21.4
8.37625-8.38675	156.7-156.9	2690-2900	22.01-23.12
8.41425-8.41475	162.0125-167.17	3260-3267	23.6-24.G
12.29-12.293	167.72-173.2	3332-3339	31.2-31.8
12.51975-12.52025	240-285	3345.8-3358	36.43-36.5
12.57675-12.57725	322-335.4	3600-4400	( <sup>2</sup> )
13.36-13.41			

## 8.3.2 FCC 15.209 Limit.

FREQUENCY MHz	DISTANCE Meters	FIELD STRENGTHS LIMIT	
		$\mu\text{V}/\text{m}$	$\text{dB}(\mu\text{V})/\text{m}$
0.009 ~ 0.490	300	2400/F(KHz)	67.6-20log(F)
0.490 ~ 1.705	30	24000/F(KHz)	87.6-20log(F)
1.705 ~ 30.0	30	30	29.54
30 ~ 88	3	100	40.0
88 ~ 216	3	150	43.5
216 ~ 960	3	200	46.0
960 ~ 1000	3	500	54.0
Above 1000	3	74.0 $\text{dB}(\mu\text{V})/\text{m}$ (Peak) 54.0 $\text{dB}(\mu\text{V})/\text{m}$ (Average)	

Note: (1) The emission limits shown in the above table are based on measurements employing a CISPR QP detector except for the frequency bands 9-90KHz, 110-490KHz and above 1000MHz. Radiated emissions limits in these three bands are based on measurements employing an average detector.

(2) At frequencies below 30MHz, measurement may be performed at a distance closer than that specified, and the limit at closer measurement distance can be extrapolated by below formula:

$$\text{Limit}_{3\text{m}}(\text{dB}\mu\text{V}/\text{m}) = \text{Limit}_{30\text{m}}(\text{dB}\mu\text{V}/\text{m}) + 40\text{Log}(30\text{m}/3\text{m})$$

## 8.3.3 Limit for this EUT

All the emissions appearing within 15.205 restricted frequency bands shall not exceed the limits shown in 15.209, all the other emissions shall be at least 20dB below the fundamental emissions, or comply with 15.209 limits.

## 9.3. Test Procedure

- (1) EUT height should be 0.8m for below 1GHz at a semi - anechoic chamber while EUT height should be 1.5m for above 1GHz at full chamber or semi - anechoic chamber ground with absorbers
- (2) Setup EUT and assistant system according clause 2.3 and 8.2
- (3) Test antenna was located 3m from the EUT on an adjustable mast, and the antenna used as below table.

Test frequency range	Test antenna used	Test distance
9KHz-30MHz	Active Loop antenna	3m
30MHz-1GHz	Trilog Broadband Antenna	3m
1GHz-18GHz	Double Ridged Horn Antenna(1GHz-18GHz)	3m
18GHz-40GHz	Horn Antenna(18GHz-40GHz)	1m

According ANSI C63.10:2013 clause 6.4.4.2 and 6.5.3, for measurements below 30 MHz, the loop antenna was positioned with its plane vertical from the EUT and rotated about its vertical axis for maximum response at each azimuth position around the EUT. And the loop antenna also be positioned with its plane horizontal at the specified distance from the EUT. The center of the loop is 1 m above the ground. for measurement above 30MHz, the Trilog Broadband Antenna or Horn Antenna was located 3m from EUT, Measurements were made with the antenna positioned in both the horizontal and vertical planes of

Polarization, and the measurement antenna was varied from 1 m to 4 m. in height above the reference

ground plane to obtain the maximum signal strength.

(4) Below pre-scan procedure was first performed in order to find prominent frequency spectrum radiated emissions from 9KHz to 25GHz:

(a) Scanning the peak frequency spectrum with the antenna specified in step (3), and the EUT was rotated 360 degree, the antenna height was varied from 1m to 4m(Except loop antenna, it's fixed 1m above ground.)

(b) Change work frequency or channel of device if practicable.

(c) Change modulation type of device if practicable.

(d) Change power supply range from 85% to 115% of the rated supply voltage

(e) Rotated EUT though three orthogonal axes to determine the attitude of EUT arrangement produces highest emissions.

Spectrum frequency from 9KHz to 25GHz (tenth harmonic of fundamental frequency) was investigated, and no any obvious emission were detected from 9KHz to 30MHz and 18GHz to 25GHz, so below final test was performed with frequency range from 30MHz to 18GHz.

(5) For final emissions measurements at each frequency of interest, the EUT was rotated and the antenna height was varied between 1m and 4m in order to maximize the emission. Measurements in both horizontal and vertical polarities were made and the data was recorded. In order to find the maximum emission, the relative positions of equipments and all of the interface cables were changed according to ANSI C63.10 2013 on Radiated Emission test.

(6) The emissions from 9KHz to 1GHz were measured based on CISPR QP detector except for the frequency bands 9-90KHz, 110-490KHz, for emissions from 9KHz-90KHz,110KHz-490KHz and above 1GHz were measured based on average detector, for emissions above 1GHz, peak emissions also be measured and need comply with Peak limit.

(7) The emissions from 9KHz to 1GHz, QP or average values were measured with EMI receiver with below RBW

Frequency band	RBW
9KHz-150KHz	200Hz
150KHz-30MHz	9KHz
30MHz-1GHz	120KHz

(8) For emissions above 1GHz, both Peak and Average level were measured with Spectrum Analyzer, and the RBW is set at 1MHz, VBW is set at 3MHz ,Peak detector for Peak measure , RMS detector for AV value

#### 9.4. Test result

##### **PASS. (See below detailed test result)**

All the emissions except fundamental emission from 9KHz to 40GHz were comply with 15.209 limit.

Note1: According exploratory test no any obvious emission were detected from 9KHz to 30MHz and 18GHz to 40GHz, so the final test was performed with frequency range from 30MHz to 18GHz and recorded in below.

Note2: For emissions below 1GHz, according exploratory explorer test, when change Tx mode and channel, have no distinct influence on emissions level, so for emissions below 1GHz, the final test was only performed with EUT working in 11a mode.

Note3: For below test data, when the limit tabular marked “/” means this frequency point is the fundamental emission and no need comply with this limit.

Radiated Emission test (below 1GHz)

# TR-4-E-009 Radiated Emission Test Result

<b>Test Site</b>	: DDT 3m Chamber 1#	D:\2017 RE1# Report Data\Q17112903-1E\Q17112903-1E FCC 30M-1G.EM6	
<b>Test Date</b>	: 2017-12-26	<b>Tested By</b>	: TALENT
<b>EUT</b>	: Wireless speaker	<b>Model Number</b>	: ALLURE PORTABLE
<b>Power Supply</b>	: AC120V/60Hz	<b>Test Mode</b>	: TX mode
<b>Condition</b>	: Temp:24.5°C,Humi:55%, Press:100.1kPa	<b>Antenna/Distance</b>	: 2017 VULB 9163 1#/3m/VERTICAL
<b>Memo</b>	:		

Data: 7

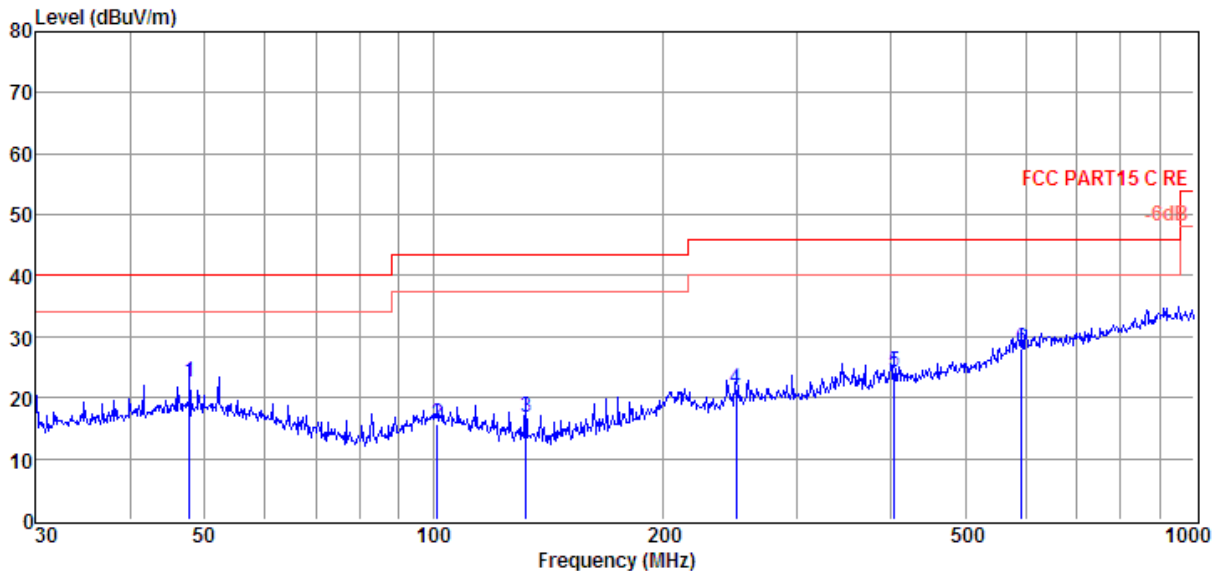

Item (Mark)	Freq. (MHz)	Read Level (dBµV)	Antenna Factor (dB/m)	Cable Loss (dB)	Result Level (dBµV/m)	Limit Line (dBµV/m)	Over Limit (dB)	Detector	Polarization
1	47.83	5.05	13.56	3.97	22.58	40.00	-17.42	QP	VERTICAL
2	101.29	-0.02	11.34	4.42	15.74	43.50	-27.76	QP	VERTICAL
3	132.22	3.93	8.07	4.66	16.66	43.50	-26.84	QP	VERTICAL
4	250.30	3.58	12.50	5.30	21.38	46.00	-24.62	QP	VERTICAL
5	403.25	3.06	15.28	5.93	24.27	46.00	-21.73	QP	VERTICAL
6	593.05	2.17	19.28	6.58	28.03	46.00	-17.97	QP	VERTICAL

- Note: 1. Result Level = Read Level + Antenna Factor + Cable loss.  
 2. If Peak Result complies with QP limit, QP Result is deemed to comply with QP limit.  
 3. Test setup: RBW: 120 kHz, VBW: 300 kHz, Sweep time: auto.

# TR-4-E-009 Radiated Emission Test Result

<b>Test Site</b>	: DDT 3m Chamber 1#	D:\2017 RE1# Report Data\Q17112903-1E\Q17112903-1E FCC 30M-1G.EM6
<b>Test Date</b>	: 2017-12-26	<b>Tested By</b> : TALENT
<b>EUT</b>	: Wireless speaker	<b>Model Number</b> : ALLURE PORTABLE
<b>Power Supply</b>	: AC120V/60Hz	<b>Test Mode</b> : TX mode
<b>Condition</b>	: Temp:24.5°C,Humi:55%, Press:100.1kPa	<b>Antenna/Distance</b> : 2017 VULB 9163 1#/3m/HORIZONTAL
<b>Memo</b>	:	

Data: 8

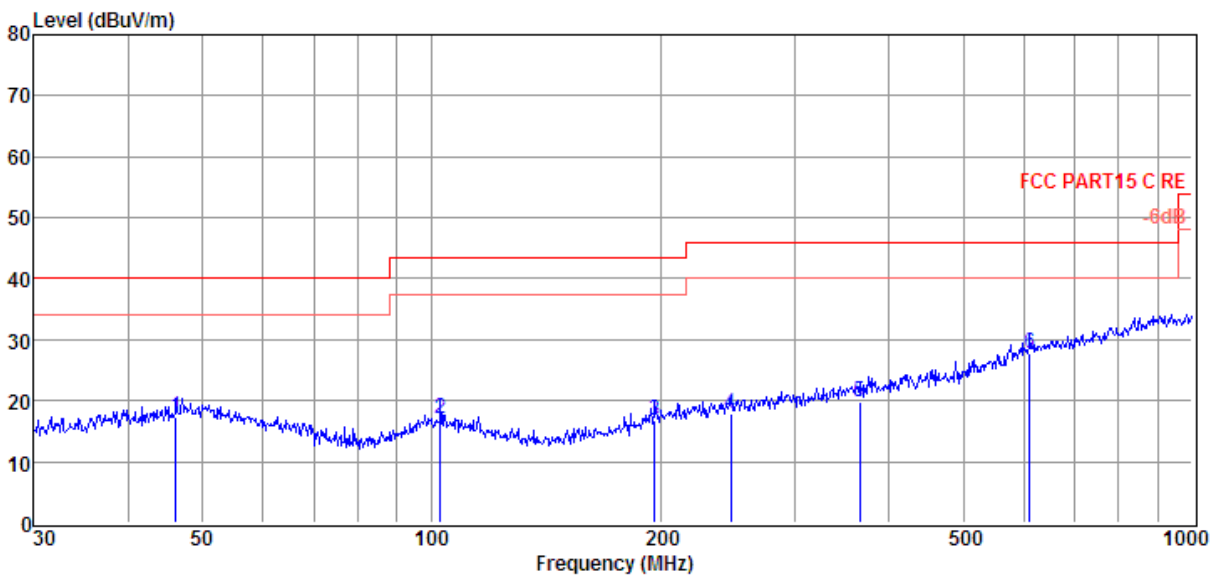

Item (Mark)	Freq. (MHz)	Read Level (dBµV)	Antenna Factor (dB/m)	Cable Loss (dB)	Result Level (dBµV/m)	Limit Line (dBµV/m)	Over Limit (dB)	Detector	Polarization
1	46.18	-0.06	13.37	3.95	17.26	40.00	-22.74	QP	HORIZONTAL
2	102.72	1.53	11.16	4.43	17.12	43.50	-26.38	QP	HORIZONTAL
3	196.51	0.51	11.20	5.00	16.71	43.50	-26.79	QP	HORIZONTAL
4	247.68	0.26	12.45	5.28	17.99	46.00	-28.01	QP	HORIZONTAL
5	365.54	-0.69	14.60	5.82	19.73	46.00	-26.27	QP	HORIZONTAL
6	612.06	1.53	19.44	6.71	27.68	46.00	-18.32	QP	HORIZONTAL

- Note: 1. Result Level = Read Level + Antenna Factor + Cable loss.  
 2. If Peak Result complies with QP limit, QP Result is deemed to comply with QP limit.  
 3. Test setup: RBW: 120 kHz, VBW: 300 kHz, Sweep time: auto.

**Radiated Emission test (above 1GHz)**

Freq (MHz)	Read level (dB $\mu$ V)	Antenna Factor (dB/m)	PRM Factor(dB)	Cable Loss (dB)	Result Level (dB $\mu$ V/m)	Limit (dB $\mu$ V/m)	Margin (dB)	Detector type	Polarization
<b>11a CH36</b>									
6134.00	34.45	35.83	29.31	9.74	50.71	74.00	-23.29	Peak	VERTICAL
7664.00	34.92	37.13	30.96	10.95	52.04	74.00	-21.96	Peak	VERTICAL
8854.00	34.59	37.47	32.22	11.76	51.60	74.00	-22.40	Peak	VERTICAL
9704.00	34.04	38.06	32.79	12.39	51.70	74.00	-22.30	Peak	VERTICAL
10775.00	33.98	38.67	33.59	13.14	52.20	74.00	-21.80	Peak	VERTICAL
12016.00	34.07	38.90	34.80	14.24	52.41	74.00	-21.59	Peak	VERTICAL
6984.00	35.60	36.77	30.38	10.40	52.39	74.00	-21.61	Peak	HORIZONTAL
8021.00	34.54	37.21	31.17	11.16	51.74	74.00	-22.26	Peak	HORIZONTAL
9704.00	34.85	38.06	32.79	12.39	52.51	74.00	-21.49	Peak	HORIZONTAL
11200.00	33.22	38.80	34.25	13.52	51.29	74.00	-22.71	Peak	HORIZONTAL
11965.00	34.25	38.89	34.78	14.18	52.54	74.00	-21.46	Peak	HORIZONTAL
13410.00	34.69	39.89	35.38	14.78	53.98	74.00	-20.02	Peak	HORIZONTAL
<b>11a CH40</b>									
6814.00	34.22	36.47	30.25	8.31	48.75	74.00	-25.25	Peak	VERTICAL
8055.00	35.10	37.22	31.18	9.29	50.43	74.00	-23.57	Peak	VERTICAL
9160.00	34.30	37.63	32.39	10.45	49.99	74.00	-24.01	Peak	VERTICAL
10350.00	34.85	38.44	33.15	10.95	51.09	74.00	-22.91	Peak	VERTICAL
11234.00	33.96	38.80	34.25	11.04	49.55	74.00	-24.45	Peak	VERTICAL
12560.00	34.21	39.05	35.31	11.18	49.13	74.00	-24.87	Peak	VERTICAL
6440.00	34.13	35.89	29.74	8.26	48.54	74.00	-25.46	Peak	HORIZONTAL
8140.00	34.52	37.26	31.24	9.39	49.93	74.00	-24.07	Peak	HORIZONTAL
9636.00	34.11	38.01	32.75	10.70	50.07	74.00	-23.93	Peak	HORIZONTAL
10979.00	33.72	38.79	33.92	11.06	49.65	74.00	-24.35	Peak	HORIZONTAL
12186.00	33.38	38.94	34.92	11.04	48.44	74.00	-25.56	Peak	HORIZONTAL
13546.00	33.87	40.01	35.12	11.90	50.66	74.00	-23.34	Peak	HORIZONTAL
<b>11a CH48</b>									
6916.00	34.42	36.65	30.33	8.32	49.06	74.00	-24.94	Peak	VERTICAL
7834.00	34.72	37.17	31.07	9.08	49.90	74.00	-24.10	Peak	VERTICAL
9415.00	34.14	37.83	32.57	10.59	49.99	74.00	-24.01	Peak	VERTICAL
10350.00	34.15	38.44	33.15	10.95	50.39	74.00	-23.61	Peak	VERTICAL
11319.00	33.57	38.80	34.38	11.03	49.02	74.00	-24.98	Peak	VERTICAL
12594.00	34.75	39.08	35.36	11.20	49.67	74.00	-24.33	Peak	VERTICAL
6134.00	34.26	35.83	29.31	8.23	49.01	74.00	-24.99	Peak	HORIZONTAL
7324.00	35.28	36.99	30.59	8.62	50.30	74.00	-23.70	Peak	HORIZONTAL
9585.00	33.43	37.97	32.71	10.67	49.36	74.00	-24.64	Peak	HORIZONTAL
9755.00	33.55	38.10	32.82	10.76	49.59	74.00	-24.41	Peak	HORIZONTAL
10571.00	33.21	38.54	33.33	10.99	49.41	74.00	-24.59	Peak	HORIZONTAL
11710.00	33.51	38.84	34.64	11.00	48.71	74.00	-25.29	Peak	HORIZONTAL
<b>Conclusion: Pass</b>									
Note: -27 dBm/MHz Limit=95.2+EIRP[dBm]=95.2-27=68.2 dB $\mu$ V/m For transmitters operating in the 5150MHz-5250MHz, 5250MHz-5350MHz, 5470MHz-5725MHz, 5725MHz-5850MHz band: all emissions outside of the 5.15-5.35 GHz band shall not exceed an EIRP of -27 dBm/MHz.									

Note: 1.30MHz~40GHz: (11a, 11n20, n40, 11ac20, 11ac40, 11ac80 mode ANT 1 ANT 2 mode all have been tested, only ANT 2 mode is worse case and reported, the worst case is 11a Mode.)

2. Result Level = Read Level + Antenna Factor + Cable loss - PRM Factor.

3. Test setup: RBW: 1 MHz, VBW: 3 MHz, Sweep time: auto.

Freq (MHz)	Read level (dBμV)	Antenna Factor (dB/m)	PRM Factor(dB)	Cable Loss (dB)	Result Level (dBμV/m)	Limit (dBμV/m)	Margin (dB)	Detector type	Polarization
<b>11a CH52</b>									
7171.00	33.99	36.90	30.48	8.48	48.89	74.00	-25.11	Peak	VERTICAL
8854.00	33.68	37.47	32.22	10.20	49.13	74.00	-24.87	Peak	VERTICAL
9534.00	34.35	37.93	32.69	10.65	50.24	74.00	-23.76	Peak	VERTICAL
10690.00	32.81	38.61	33.47	11.01	48.96	74.00	-25.04	Peak	VERTICAL
12016.00	33.04	38.90	34.80	10.98	48.12	74.00	-25.88	Peak	VERTICAL
13206.00	34.27	39.65	35.54	11.56	49.94	74.00	-24.06	Peak	VERTICAL
6389.00	35.12	35.88	29.60	8.26	49.66	74.00	-24.34	Peak	HORIZONTAL
7851.00	34.86	37.17	31.07	9.10	50.06	74.00	-23.94	Peak	HORIZONTAL
10401.00	35.59	38.46	33.20	10.96	51.81	74.00	-22.19	Peak	HORIZONTAL
10520.00	36.30	38.51	33.28	10.98	52.51	74.00	-21.49	Peak	HORIZONTAL
11030.00	33.16	38.80	34.03	11.06	48.99	74.00	-25.01	Peak	HORIZONTAL
13036.00	34.27	39.44	35.67	11.39	49.43	74.00	-24.57	Peak	HORIZONTAL
<b>11a CH56</b>									
7205.00	33.93	36.92	30.49	8.51	48.87	74.00	-25.13	Peak	VERTICAL
7766.00	34.27	37.15	31.02	9.02	49.42	74.00	-24.58	Peak	VERTICAL
9160.00	33.84	37.63	32.39	10.45	49.53	74.00	-24.47	Peak	VERTICAL
10180.00	34.03	38.37	33.03	10.92	50.29	74.00	-23.71	Peak	VERTICAL
11234.00	32.85	38.80	34.25	11.04	48.44	74.00	-25.56	Peak	VERTICAL
12866.00	34.25	39.29	35.64	11.30	49.20	74.00	-24.80	Peak	VERTICAL
6984.00	34.03	36.77	30.38	8.33	48.75	74.00	-25.25	Peak	HORIZONTAL
8055.00	34.29	37.22	31.18	9.29	49.62	74.00	-24.38	Peak	HORIZONTAL
9704.00	34.01	38.06	32.79	10.74	50.02	74.00	-23.98	Peak	HORIZONTAL
10775.00	33.41	38.67	33.59	11.02	49.51	74.00	-24.49	Peak	HORIZONTAL
12016.00	33.27	38.90	34.80	10.98	48.35	74.00	-25.65	Peak	HORIZONTAL
13461.00	34.17	39.95	35.22	11.82	50.72	74.00	-23.28	Peak	HORIZONTAL
<b>11a CH64</b>									
7120.00	34.57	36.87	30.44	8.44	49.44	74.00	-24.56	Peak	VERTICAL
9109.00	33.98	37.59	32.36	10.43	49.64	74.00	-24.36	Peak	VERTICAL
10520.00	33.28	38.51	33.28	10.98	49.49	74.00	-24.51	Peak	VERTICAL
11455.00	33.62	38.80	34.49	11.02	48.95	74.00	-25.05	Peak	VERTICAL
12441.00	33.93	38.99	35.16	11.14	48.90	74.00	-25.10	Peak	VERTICAL
13444.00	34.50	39.93	35.28	11.80	50.95	74.00	-23.05	Peak	VERTICAL
7001.00	34.22	36.80	30.39	8.33	48.96	74.00	-25.04	Peak	HORIZONTAL
7766.00	34.51	37.15	31.02	9.02	49.66	74.00	-24.34	Peak	HORIZONTAL
9109.00	34.51	37.59	32.36	10.43	50.17	74.00	-23.83	Peak	HORIZONTAL
9976.00	33.77	38.28	32.91	10.88	50.02	74.00	-23.98	Peak	HORIZONTAL
11591.00	34.13	38.82	34.56	11.01	49.40	74.00	-24.60	Peak	HORIZONTAL
13104.00	34.59	39.52	35.64	11.46	49.93	74.00	-24.07	Peak	HORIZONTAL
Conclusion: Pass									
Note: -27 dBm/MHz Limit=95.2+EIRP[dBm]=95.2-27=68.2 dBμV/m For transmitters operating in the 5150MHz-5250MHz, 5250MHz-5350MHz, 5470MHz-5725MHz, 5725MHz-5850MHz band: all emissions outside of the 5.15-5.35 GHz band shall not exceed an EIRP of -27 dBm/MHz.									

Note: 1.30MHz~40GHz: (11a, 11n20, n40, 11ac20, 11ac40, 11ac80 mode ANT 1 ANT 2 mode all have been tested, only ANT 2 mode is worse case and reported, the worst case is 11a Mode.)

2. Result Level = Read Level + Antenna Factor + Cable loss - PRM Factor.

3. Test setup: RBW: 1 MHz, VBW: 3 MHz, Sweep time: auto.

Freq (MHz)	Read level (dBμV)	Antenna Factor (dB/m)	PRM Factor(dB)	Cable Loss (dB)	Result Level (dBμV/m)	Limit (dBμV/m)	Margin (dB)	Detector type	Polarization
<b>11a CH110</b>									
5896.00	33.84	35.76	29.20	8.14	48.54	74.00	-25.46	Peak	VERTICAL
7766.00	34.64	37.15	31.02	9.02	49.79	74.00	-24.21	Peak	VERTICAL
8990.00	34.34	37.50	32.32	10.36	49.88	74.00	-24.12	Peak	VERTICAL
9874.00	34.45	38.20	32.87	10.82	50.60	74.00	-23.40	Peak	VERTICAL
10571.00	33.98	38.54	33.33	10.99	50.18	74.00	-23.82	Peak	VERTICAL
11319.00	33.39	38.80	34.38	11.03	48.84	74.00	-25.16	Peak	VERTICAL
6916.00	34.61	36.65	30.33	8.32	49.25	74.00	-24.75	Peak	HORIZONTAL
9534.00	33.95	37.93	32.69	10.65	49.84	74.00	-24.16	Peak	HORIZONTAL
10214.00	33.88	38.39	33.04	10.93	50.16	74.00	-23.84	Peak	HORIZONTAL
10724.00	33.63	38.63	33.51	11.01	49.76	74.00	-24.24	Peak	HORIZONTAL
11761.00	33.22	38.85	34.68	10.99	48.38	74.00	-25.62	Peak	HORIZONTAL
13444.00	33.83	39.93	35.28	11.80	50.28	74.00	-23.72	Peak	HORIZONTAL
<b>11a CH116</b>									
6916.00	35.03	36.65	30.33	8.32	49.67	74.00	-24.33	Peak	VERTICAL
9211.00	34.10	37.67	32.42	10.48	49.83	74.00	-24.17	Peak	VERTICAL
9789.00	34.43	38.13	32.84	10.78	50.50	74.00	-23.50	Peak	VERTICAL
10690.00	33.47	38.61	33.47	11.01	49.62	74.00	-24.38	Peak	VERTICAL
12016.00	33.95	38.90	34.80	10.98	49.03	74.00	-24.97	Peak	VERTICAL
13376.00	34.50	39.85	35.38	11.73	50.70	74.00	-23.30	Peak	VERTICAL
6916.00	35.50	36.65	30.33	8.32	50.14	74.00	-23.86	Peak	HORIZONTAL
8395.00	34.60	37.36	31.55	9.68	50.09	74.00	-23.91	Peak	HORIZONTAL
9245.00	34.39	37.70	32.45	10.50	50.14	74.00	-23.86	Peak	HORIZONTAL
10639.00	33.33	38.58	33.43	11.00	49.48	74.00	-24.52	Peak	HORIZONTAL
11795.00	33.61	38.86	34.70	10.99	48.76	74.00	-25.24	Peak	HORIZONTAL
13410.00	35.40	39.89	35.38	11.76	51.67	74.00	-22.33	Peak	HORIZONTAL
<b>11a CH140</b>									
6950.00	34.73	36.71	30.34	8.32	49.42	74.00	-24.58	Peak	VERTICAL
8446.00	34.72	37.38	31.63	9.74	50.21	74.00	-23.79	Peak	VERTICAL
9415.00	33.91	37.83	32.57	10.59	49.76	74.00	-24.24	Peak	VERTICAL
10911.00	34.02	38.75	33.74	11.04	50.07	74.00	-23.93	Peak	VERTICAL
11795.00	34.08	38.86	34.70	10.99	49.23	74.00	-24.77	Peak	VERTICAL
13427.00	34.60	39.91	35.28	11.78	51.01	74.00	-22.99	Peak	VERTICAL
7086.00	34.93	36.85	30.42	8.41	49.77	74.00	-24.23	Peak	HORIZONTAL
7970.00	34.46	37.19	31.12	9.20	49.73	74.00	-24.27	Peak	HORIZONTAL
9381.00	33.81	37.80	32.52	10.57	49.66	74.00	-24.34	Peak	HORIZONTAL
10350.00	33.49	38.44	33.15	10.95	49.73	74.00	-24.27	Peak	HORIZONTAL
11540.00	33.73	38.81	34.53	11.01	49.02	74.00	-24.98	Peak	HORIZONTAL
13036.00	35.35	39.44	35.67	11.39	50.51	74.00	-23.49	Peak	HORIZONTAL
Conclusion: Pass									
Note: -27 dBm/MHz Limit=95.2+EIRP[dBm]=95.2-27=68.2 dBμV/m For transmitters operating in the 5150MHz-5250MHz, 5250MHz-5350MHz, 5470MHz-5725MHz, 5725MHz-5850MHz band: all emissions outside of the 5.15-5.35 GHz band shall not exceed an EIRP of -27 dBm/MHz.									

Note: 1.30MHz~40GHz:(11a, 11n20, n40, 11ac20, 11ac40, 11ac80 mode ANT 1 ANT 2 mode all have been tested, only ANT 2 mode is worse case and reported, the worst case is 11a Mode.)

2. Result Level = Read Level + Antenna Factor + Cable loss - PRM Factor.

3. Test setup: RBW: 1 MHz, VBW: 3 MHz, Sweep time: auto.

Freq (MHz)	Read level (dBμV)	Antenna Factor (dB/m)	PRM Factor(dB)	Cable Loss (dB)	Result Level (dBμV/m)	Limit (dBμV/m)	Margin (dB)	Detector type	Polarization
<b>11a CH149</b>									
7154.00	34.51	36.89	30.45	8.47	49.42	74.00	-24.58	Peak	VERTICAL
8225.00	34.22	37.29	31.33	9.49	49.67	74.00	-24.33	Peak	VERTICAL
9296.00	33.59	37.74	32.48	10.52	49.37	74.00	-24.63	Peak	VERTICAL
10571.00	33.99	38.54	33.33	10.99	50.19	74.00	-23.81	Peak	VERTICAL
11761.00	33.62	38.85	34.68	10.99	48.78	74.00	-25.22	Peak	VERTICAL
13801.00	34.39	40.06	34.88	12.16	51.73	74.00	-22.27	Peak	VERTICAL
6780.00	35.68	36.40	30.24	8.30	50.14	74.00	-23.86	Peak	HORIZONTAL
9160.00	33.88	37.63	32.39	10.45	49.57	74.00	-24.43	Peak	HORIZONTAL
9755.00	34.18	38.10	32.82	10.76	50.22	74.00	-23.78	Peak	HORIZONTAL
10520.00	34.34	38.51	33.28	10.98	50.55	74.00	-23.45	Peak	HORIZONTAL
12016.00	34.39	38.90	34.80	10.98	49.47	74.00	-24.53	Peak	HORIZONTAL
13410.00	35.14	39.89	35.38	11.76	51.41	74.00	-22.59	Peak	HORIZONTAL
<b>11a CH157</b>									
6984.00	35.21	36.77	30.38	8.33	49.93	74.00	-24.07	Peak	VERTICAL
8021.00	36.27	37.21	31.17	9.25	51.56	74.00	-22.44	Peak	VERTICAL
9568.00	34.13	37.95	32.71	10.67	50.04	74.00	-23.96	Peak	VERTICAL
10435.00	34.24	38.47	33.22	10.96	50.45	74.00	-23.55	Peak	VERTICAL
11421.00	33.52	38.80	34.46	11.02	48.88	74.00	-25.12	Peak	VERTICAL
13104.00	34.64	39.52	35.64	11.46	49.98	74.00	-24.02	Peak	VERTICAL
6984.00	34.51	36.77	30.38	8.33	49.23	74.00	-24.77	Peak	HORIZONTAL
9041.00	35.08	37.53	32.34	10.39	50.66	74.00	-23.34	Peak	HORIZONTAL
10146.00	34.44	38.36	33.01	10.91	50.70	74.00	-23.30	Peak	HORIZONTAL
11081.00	34.49	38.80	34.08	11.05	50.26	74.00	-23.74	Peak	HORIZONTAL
12866.00	33.90	39.29	35.64	11.30	48.85	74.00	-25.15	Peak	HORIZONTAL
13750.00	34.52	40.05	34.95	12.11	51.73	74.00	-22.27	Peak	HORIZONTAL
<b>11a CH165</b>									
6950.00	36.10	36.71	30.34	8.32	50.79	74.00	-23.21	Peak	VERTICAL
8735.00	34.10	37.45	32.07	10.07	49.55	74.00	-24.45	Peak	VERTICAL
10350.00	34.05	38.44	33.15	10.95	50.29	74.00	-23.71	Peak	VERTICAL
11251.00	33.21	38.80	34.28	11.04	48.77	74.00	-25.23	Peak	VERTICAL
11999.00	34.41	38.90	34.80	10.97	49.48	74.00	-24.52	Peak	VERTICAL
13461.00	34.48	39.95	35.22	11.82	51.03	74.00	-22.97	Peak	VERTICAL
6491.00	34.87	35.90	29.83	8.27	49.21	74.00	-24.79	Peak	HORIZONTAL
8531.00	34.65	37.41	31.82	9.84	50.08	74.00	-23.92	Peak	HORIZONTAL
9075.00	35.00	37.56	32.35	10.41	50.62	74.00	-23.38	Peak	HORIZONTAL
10316.00	33.22	38.43	33.11	10.94	49.48	74.00	-24.52	Peak	HORIZONTAL
11251.00	34.36	38.80	34.28	11.04	49.92	74.00	-24.08	Peak	HORIZONTAL
12781.00	33.30	39.22	35.58	11.27	48.21	74.00	-25.79	Peak	HORIZONTAL
<b>Conclusion: Pass</b>									
Note: -27 dBm/MHz Limit=95.2+EIRP[dBm]=95.2-27=68.2 dBμV/m For transmitters operating in the 5150MHz-5250MHz, 5250MHz-5350MHz, 5470MHz-5725MHz, 5725MHz-5850MHz band: all emissions outside of the 5.15-5.35 GHz band shall not exceed an EIRP of -27 dBm/MHz.									

Note: 1.30MHz~40GHz: (11a, 11n20, n40, 11ac20, 11ac40, 11ac80 mode ANT 1 ANT 2 mode all have been tested, only ANT2 mode is worse case and reported, the worst case is 11a Mode.)

2. Result Level = Read Level + Antenna Factor + Cable loss - PRM Factor.

3. Test setup: RBW: 1 MHz, VBW: 3 MHz, Sweep time: auto.

## 10. Band Edge Compliance

### 10.1. Block diagram of test setup

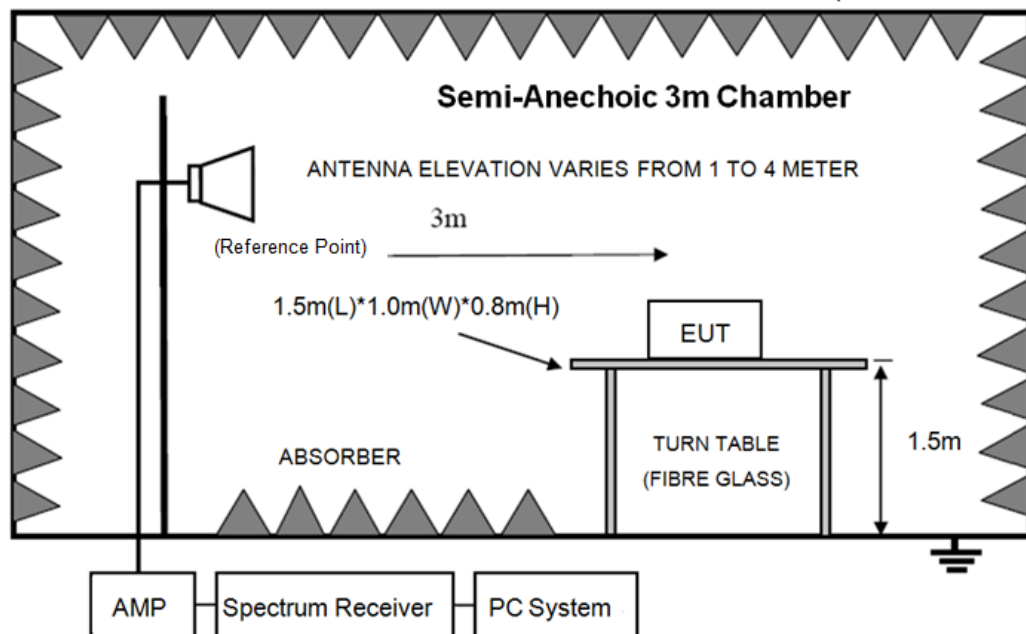

### 10.2. Limit

For transmitters operating in the 5.15-5.25 GHz and 5.725-5.85G band: all emissions outside of the 5.15-5.35 GHz band shall not exceed an EIRP of -27 dBm/MHz.

$$-27 \text{ dBm/MHz Limit} = 95.2 + \text{EIRP}[\text{dBm}] = 95.2 - 27 = 68.2 \text{ dB}\mu\text{V/m}$$

### 10.3. Test Procedure

Same with clause 8.3 except change investigated frequency range from 5.15-5.25 GHz, 5250-5350GHz, 5470-5725GHz, 5.725-5.85G.

Remark: All restriction band have been tested, and only the worse case is shown in report.

### 10.4. Test result

#### **PASS. (See below detailed test result)**

Note1: As specified in 15.407(b), emissions above 1000 MHz that are outside of the restricted bands are subject to a peak emission limit of -27 dBm/MHz (or -17 dBm/MHz as specified in 15.407(b)(4)). However, an out-of-band emission that complies with both the average and peak limits of 15.209 is not required to satisfy the -27 dBm/MHz or -17 dBm/MHz peak emission limit

Note2: 11a, 11n20, n40, 11ac20, 11ac40, 11ac80 mode ANT 1 ANT 2 mode all have been tested, only ANT 2 mode is worse case and reported, the worst case is 11a Mode.

# TR-4-E-009 Radiated Emission Test Result

<b>Test Site</b>	: DDT 3m Chamber 1#	D:\2017 RE1# Report Data\Q17112903-1E\Q17112904-1E FCC 1G-18G 5G WIFI .EM6
<b>Test Date</b>	: 2018-01-04	<b>Tested By</b> : Sunny
<b>EUT</b>	: Wireless speaker	<b>Model Number</b> : ALLURE PORTABLE
<b>Power Supply</b>	: AC 120V/60Hz	<b>Test Mode</b> : TX mode
<b>Condition</b>	: Temp:24.5'C,Humi:55%, Press:100.1kPa	<b>Antenna/Distance</b> : 2016 HF907/3m/HORIZONTAL
<b>Memo</b>	: 11a 5180MHz	

Data: 177

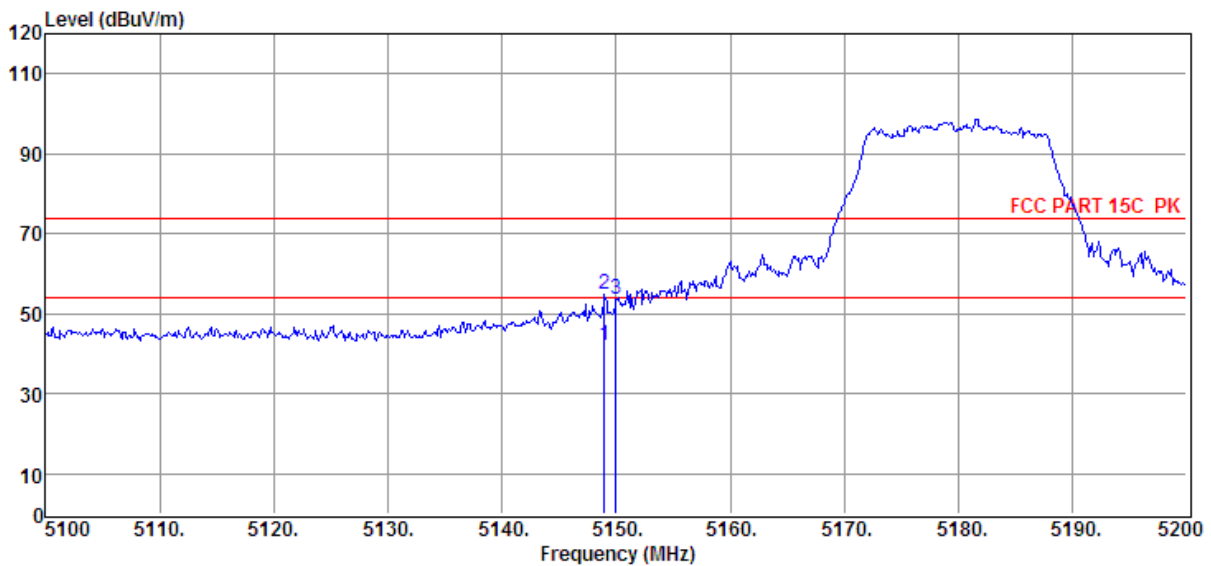

Item	Freq.	Read Level	Antenna Factor	PRM Factor	Cable Loss	Result Level	Limit Line	Over Limit	Detector	Polarization
(Mark)	(MHz)	(dBμV)	(dB/m)	dB	dB	(dBμV/m)	(dBμV/m)	(dB)		
1	5149.00	28.54	35.18	29.33	7.67	42.06	54.00	-11.94	Average	HORIZONTAL
2	5149.00	41.47	35.18	29.33	7.67	54.99	74.00	-19.01	Peak	HORIZONTAL
3	5150.00	39.93	35.18	29.33	7.67	53.45	74.00	-20.55	Peak	HORIZONTAL

- Note: 1. Result Level = Read Level + Antenna Factor + Cable loss - PRM Factor.  
 2. If Peak Result complies with AV limit, AV Result is deemed to comply with AV limit.  
 3. Test setup: RBW: 1 MHz, VBW: 3 MHz, Sweep time: auto.

# TR-4-E-009 Radiated Emission Test Result

<b>Test Site</b>	: DDT 3m Chamber 1#	<b>D:\2017 RE1# Report Data\Q17112903-1E\Q17112904-1E FCC 1G-18G 5G WIFI .EM6</b>
<b>Test Date</b>	: 2018-01-04	<b>Tested By</b> : Sunny
<b>EUT</b>	: Wireless speaker	<b>Model Number</b> : ALLURE PORTABLE
<b>Power Supply</b>	: AC 120V/60Hz	<b>Test Mode</b> : TX mode
<b>Condition</b>	: Temp:24.5'C,Humi:55%, Press:100.1kPa	<b>Antenna/Distance</b> : 2016 HF907/3m/VERTICAL
<b>Memo</b>	: 11a 5180MHz	

Data: 178

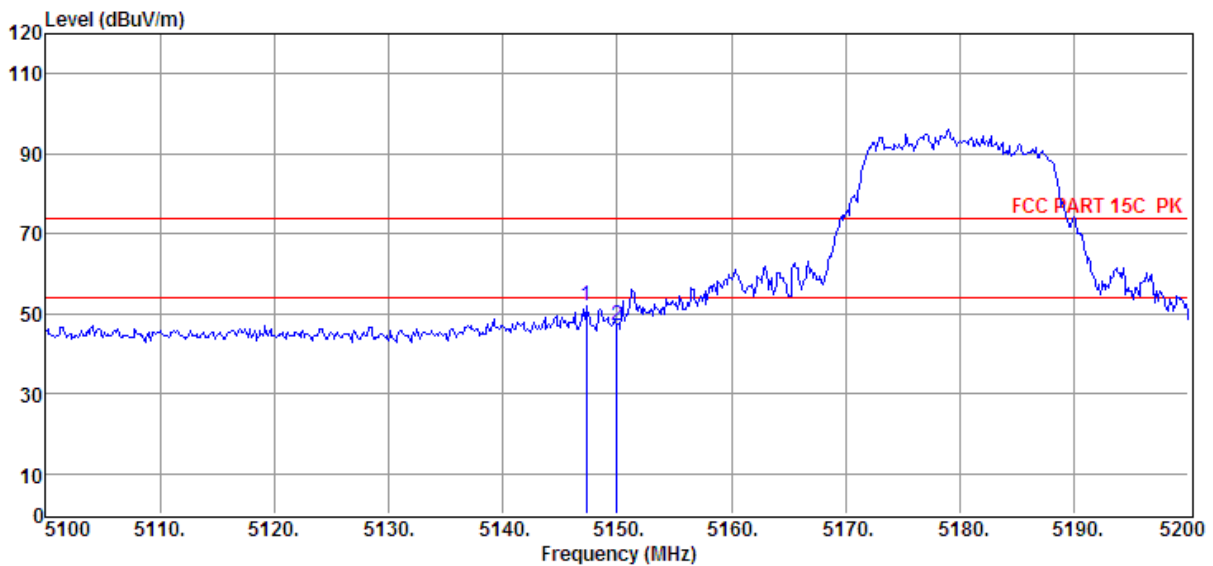

Item	Freq.	Read Level	Antenna Factor	PRM Factor	Cable Loss	Result Level	Limit Line	Over Limit	Detector	Polarization
(Mark)	(MHz)	(dBμV)	(dB/m)	dB	dB	(dBμV/m)	(dBμV/m)	(dB)		
1	5147.30	38.37	35.18	29.33	7.67	51.89	74.00	-22.11	Peak	VERTICAL
2	5150.00	33.39	35.18	29.33	7.67	46.91	74.00	-27.09	Peak	VERTICAL

- Note: 1. Result Level = Read Level + Antenna Factor + Cable loss - PRM Factor.  
 2. If Peak Result complies with AV limit, AV Result is deemed to comply with AV limit.  
 3. Test setup: RBW: 1 MHz, VBW: 3 MHz, Sweep time: auto.

# TR-4-E-009 Radiated Emission Test Result

<b>Test Site</b>	: DDT 3m Chamber 1#	<b>D:\2017 RE1# Report Data\Q17112903-1E\Q17112904-1E FCC 1G-18G 5G WIFI .EM6</b>
<b>Test Date</b>	: 2018-01-04	<b>Tested By</b> : Sunny
<b>EUT</b>	: Wireless speaker	<b>Model Number</b> : ALLURE PORTABLE
<b>Power Supply</b>	: AC 120V/60Hz	<b>Test Mode</b> : TX mode
<b>Condition</b>	: Temp:24.5'C,Humi:55%, Press:100.1kPa	<b>Antenna/Distance</b> : 2016 HF907/3m/VERTICAL
<b>Memo</b>	: 11a 5240MHz	

Data: 179

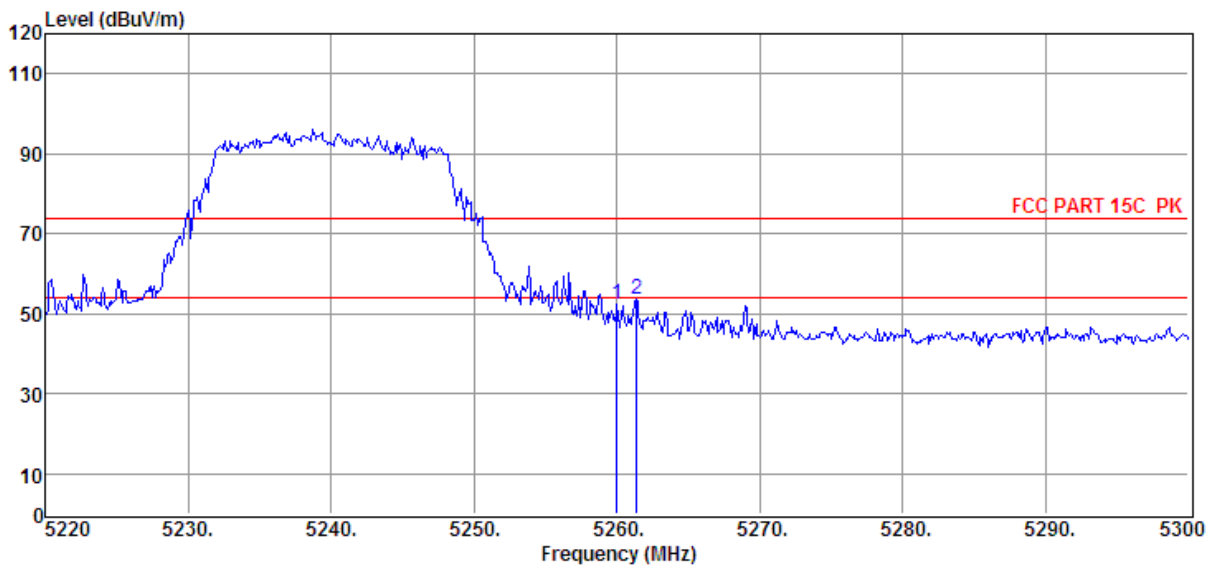

Item (Mark)	Freq. (MHz)	Read Level (dBμV)	Antenna Factor (dB/m)	PRM Factor (dB)	Cable Loss (dB)	Result Level (dBμV/m)	Limit Line (dBμV/m)	Over Limit (dB)	Detector	Polarization
1	5260.00	38.76	35.31	29.32	7.74	52.49	74.00	-21.51	Peak	VERTICAL
2	5261.36	39.68	35.31	29.32	7.74	53.41	74.00	-20.59	Peak	VERTICAL

- Note: 1. Result Level = Read Level + Antenna Factor + Cable loss - PRM Factor.  
 2. If Peak Result complies with AV limit, AV Result is deemed to comply with AV limit.  
 3. Test setup: RBW: 1 MHz, VBW: 3 MHz, Sweep time: auto.

# TR-4-E-009 Radiated Emission Test Result

<b>Test Site</b>	: DDT 3m Chamber 1#	<b>D:\2017 RE1# Report Data\Q17112903-1E\Q17112904-1E FCC 1G-18G 5G WIFI .EM6</b>
<b>Test Date</b>	: 2018-01-04	<b>Tested By</b> : Sunny
<b>EUT</b>	: Wireless speaker	<b>Model Number</b> : ALLURE PORTABLE
<b>Power Supply</b>	: AC 120V/60Hz	<b>Test Mode</b> : TX mode
<b>Condition</b>	: Temp:24.5'C,Humi:55%, Press:100.1kPa	<b>Antenna/Distance</b> : 2016 HF907/3m/HORIZONTAL
<b>Memo</b>	: 11a 5240MHz	

Data: 180

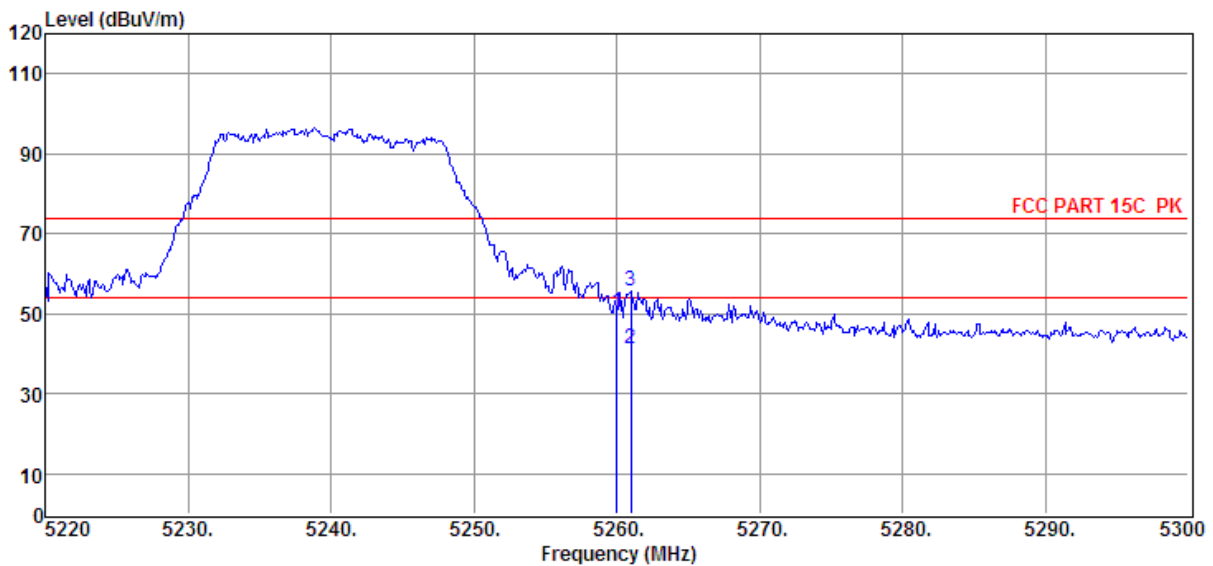

Item (Mark)	Freq. (MHz)	Read Level (dBμV)	Antenna Factor (dB/m)	PRM Factor (dB)	Cable Loss (dB)	Result Level (dBμV/m)	Limit Line (dBμV/m)	Over Limit (dB)	Detector	Polarization
1	5260.00	36.60	35.31	29.32	7.74	50.33	74.00	-23.67	Peak	HORIZONTAL
2	5260.96	27.65	35.31	29.32	7.74	41.38	54.00	-12.62	Average	HORIZONTAL
3	5260.96	41.80	35.31	29.32	7.74	55.53	74.00	-18.47	Peak	HORIZONTAL

Note: 1. Result Level = Read Level + Antenna Factor + Cable loss - PRM Factor.  
 2. If Peak Result complies with AV limit, AV Result is deemed to comply with AV limit.  
 3. Test setup: RBW: 1 MHz, VBW: 3 MHz, Sweep time: auto.

# TR-4-E-009 Radiated Emission Test Result

<b>Test Site</b>	: DDT 3m Chamber 1#	<b>D:\2017 RE1# Report Data\Q17112903-1E\Q17112904-1E FCC 1G-18G 5G WIFI .EM6</b>
<b>Test Date</b>	: 2018-01-04	<b>Tested By</b> : Sunny
<b>EUT</b>	: Wireless speaker	<b>Model Number</b> : ALLURE PORTABLE
<b>Power Supply</b>	: AC 120V/60Hz	<b>Test Mode</b> : TX mode
<b>Condition</b>	: Temp:24.5'C,Humi:55%, Press:100.1kPa	<b>Antenna/Distance</b> : 2016 HF907/3m/HORIZONTAL
<b>Memo</b>	: 11a 5260MHz	

Data: 181

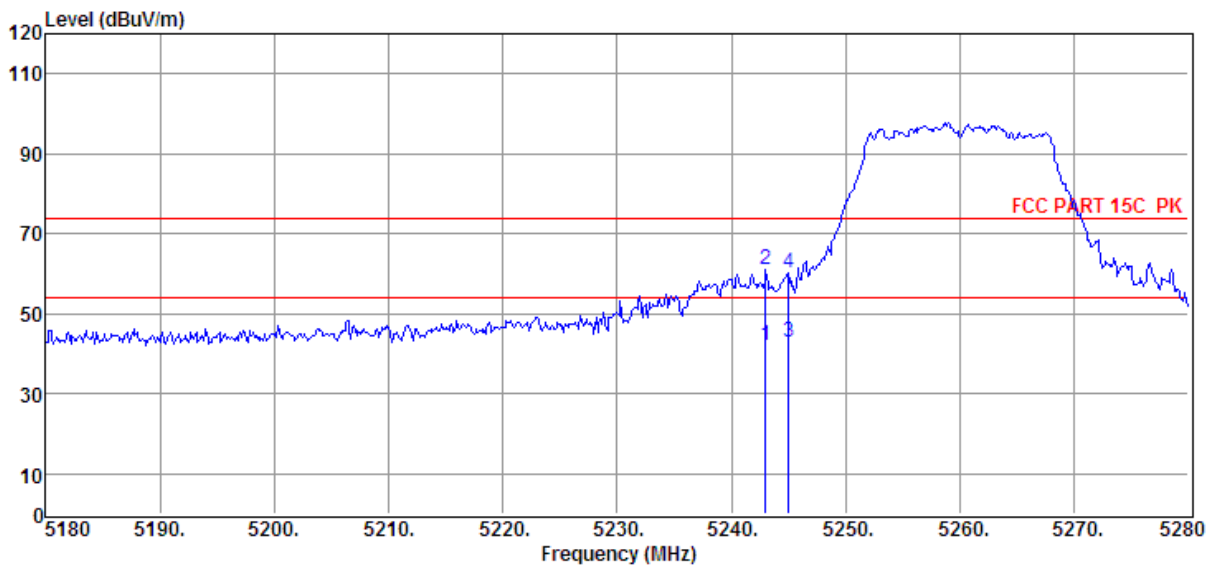

Item (Mark)	Freq. (MHz)	Read Level (dBμV)	Antenna Factor (dB/m)	PRM Factor (dB)	Cable Loss (dB)	Result Level (dBμV/m)	Limit Line (dBμV/m)	Over Limit (dB)	Detector	Polarization
1	5243.00	28.51	35.29	29.32	7.73	42.21	54.00	-11.79	Average	HORIZONTAL
2	5243.00	47.24	35.29	29.32	7.73	60.94	74.00	-13.06	Peak	HORIZONTAL
3	5245.00	29.15	35.29	29.32	7.73	42.85	54.00	-11.15	Average	HORIZONTAL
4	5245.00	46.48	35.29	29.32	7.73	60.18	74.00	-13.82	Peak	HORIZONTAL

Note: 1. Result Level = Read Level + Antenna Factor + Cable loss - PRM Factor.  
 2. If Peak Result complies with AV limit, AV Result is deemed to comply with AV limit.  
 3. Test setup: RBW: 1 MHz, VBW: 3 MHz, Sweep time: auto.

# TR-4-E-009 Radiated Emission Test Result

<b>Test Site</b>	: DDT 3m Chamber 1#	D:\2017 RE1# Report Data\Q17112903-1E\Q17112904-1E FCC 1G-18G 5G WIFI .EM6
<b>Test Date</b>	: 2018-01-04	<b>Tested By</b> : Sunny
<b>EUT</b>	: Wireless speaker	<b>Model Number</b> : ALLURE PORTABLE
<b>Power Supply</b>	: AC 120V/60Hz	<b>Test Mode</b> : TX mode
<b>Condition</b>	: Temp:24.5'C,Humi:55%, Press:100.1kPa	<b>Antenna/Distance</b> : 2016 HF907/3m/VERTICAL
<b>Memo</b>	: 11a 5260MHz	

Data: 182

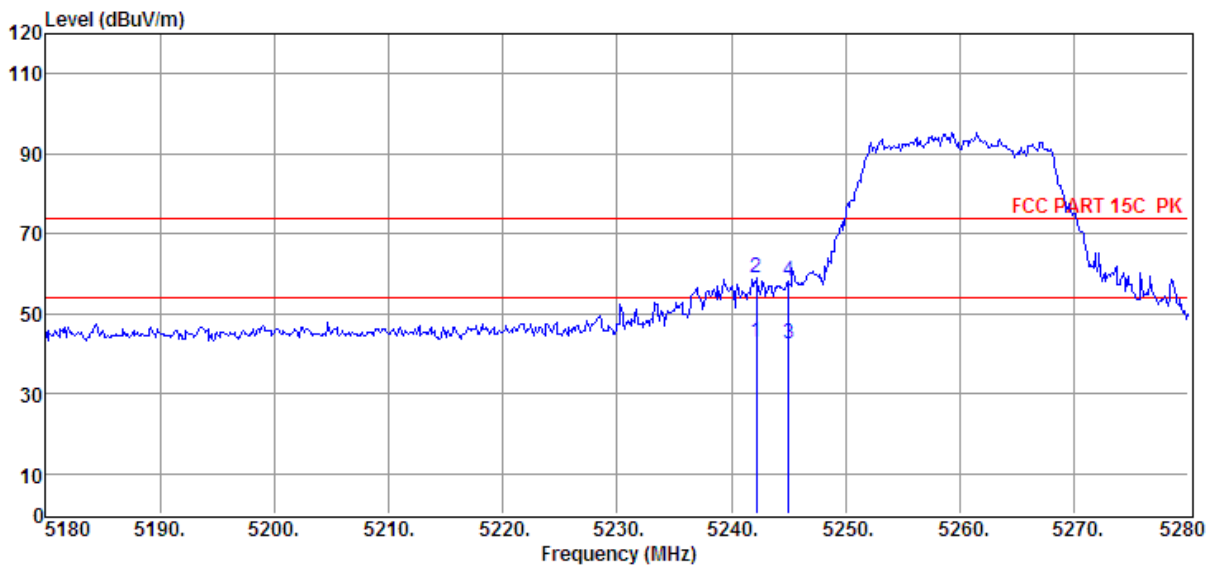

Item (Mark)	Freq. (MHz)	Read Level (dBµV)	Antenna Factor (dB/m)	PRM Facto r dB	Cable Loss dB	Result Level (dBµV/m)	Limit Line (dBµV/m)	Over Limit (dB)	Detector	Polarization
1	5242.20	29.25	35.29	29.32	7.73	42.95	54.00	-11.0 5	Average	VERTICAL
2	5242.20	45.07	35.29	29.32	7.73	58.77	74.00	-15.2 3	Peak	VERTICAL
3	5245.00	28.58	35.29	29.32	7.73	42.28	54.00	-11.7 2	Average	VERTICAL
4	5245.00	44.35	35.29	29.32	7.73	58.05	74.00	-15.9 5	Peak	VERTICAL

Note: 1. Result Level = Read Level + Antenna Factor + Cable loss - PRM Factor.  
 2. If Peak Result complies with AV limit, AV Result is deemed to comply with AV limit.  
 3. Test setup: RBW: 1 MHz, VBW: 3 MHz, Sweep time: auto.

# TR-4-E-009 Radiated Emission Test Result

<b>Test Site</b>	: DDT 3m Chamber 1#	D:\2017 RE1# Report Data\Q17112903-1E\Q17112904-1E FCC 1G-18G 5G WIFI .EM6
<b>Test Date</b>	: 2018-01-04	<b>Tested By</b> : Sunny
<b>EUT</b>	: Wireless speaker	<b>Model Number</b> : ALLURE PORTABLE
<b>Power Supply</b>	: AC 120V/60Hz	<b>Test Mode</b> : TX mode
<b>Condition</b>	: Temp:24.5'C,Humi:55%, Press:100.1kPa	<b>Antenna/Distance</b> : 2016 HF907/3m/HORIZONTAL
<b>Memo</b>	: 11a 5320MHz	

Data: 183

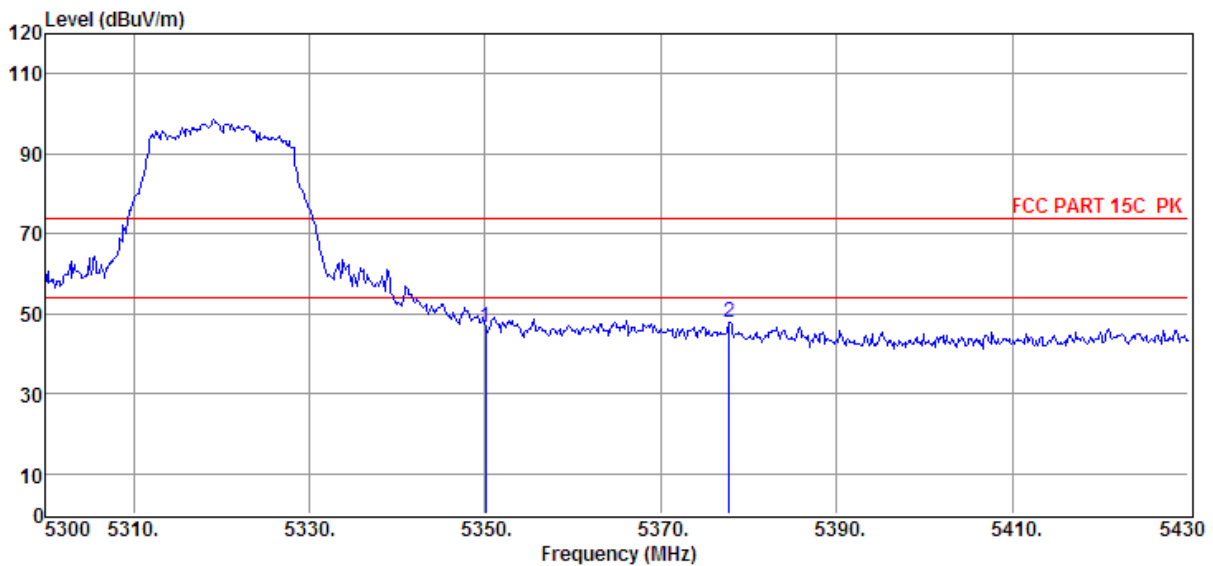

Item (Mark)	Freq. (MHz)	Read Level (dBμV)	Antenna Factor (dB/m)	PRM Facto r dB	Cable Loss dB	Result Level (dBμV/m)	Limit Line (dBμV/m)	Over Limit (dB)	Detector	Polarization
1	5350.05	32.85	35.42	29.30	7.80	46.77	74.00	-27.2 3	Peak	HORIZONTAL
2	5377.74	33.78	35.45	29.30	7.82	47.75	74.00	-26.2 5	Peak	HORIZONTAL

Note: 1. Result Level = Read Level + Antenna Factor + Cable loss - PRM Factor.  
 2. If Peak Result complies with AV limit, AV Result is deemed to comply with AV limit.  
 3. Test setup: RBW: 1 MHz, VBW: 3 MHz, Sweep time: auto.

# TR-4-E-009 Radiated Emission Test Result

<b>Test Site</b>	: DDT 3m Chamber 1#	D:\2017 RE1# Report Data\Q17112903-1E\Q17112904-1E FCC 1G-18G 5G WIFI .EM6
<b>Test Date</b>	: 2018-01-04	<b>Tested By</b> : Sunny
<b>EUT</b>	: Wireless speaker	<b>Model Number</b> : ALLURE PORTABLE
<b>Power Supply</b>	: AC 120V/60Hz	<b>Test Mode</b> : TX mode
<b>Condition</b>	: Temp:24.5'C,Humi:55%, Press:100.1kPa	<b>Antenna/Distance</b> : 2016 HF907/3m/VERTICAL
<b>Memo</b>	: 11a 5320MHz	

Data: 184

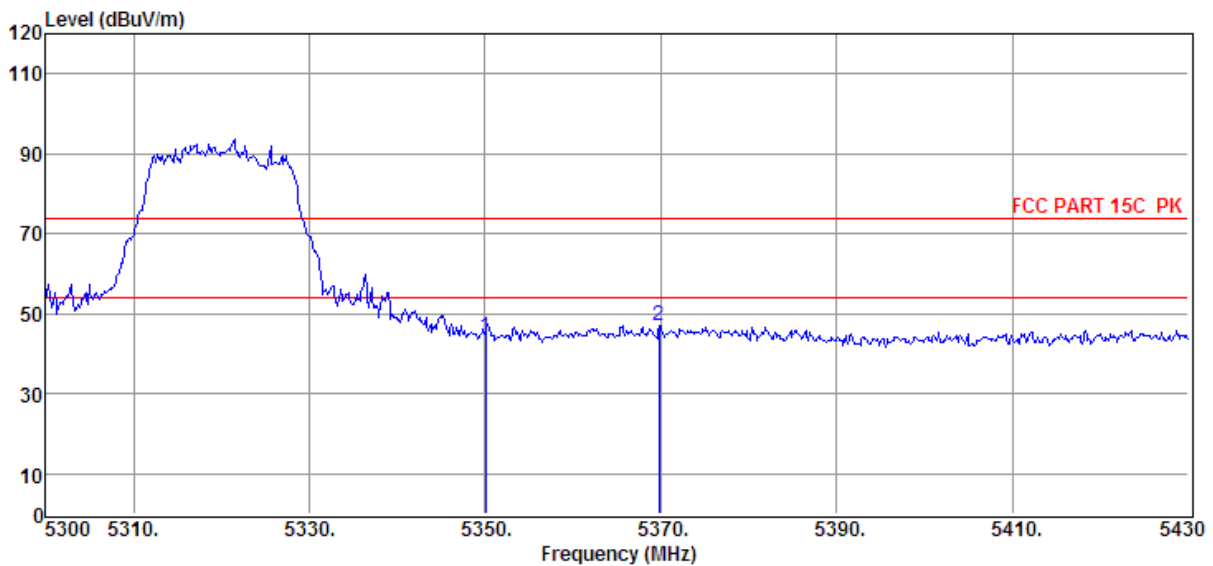

Item (Mark)	Freq. (MHz)	Read Level (dBµV)	Antenna Factor (dB/m)	PRM Facto r dB	Cable Loss dB	Result Level (dBµV/m)	Limit Line (dBµV/m)	Over Limit (dB)	Detector	Polarization
1	5350.05	30.29	35.42	29.30	7.80	44.21	74.00	-29.79	Peak	VERTICAL
2	5369.81	33.01	35.44	29.30	7.81	46.96	74.00	-27.04	Peak	VERTICAL

- Note: 1. Result Level = Read Level + Antenna Factor + Cable loss - PRM Factor.  
 2. If Peak Result complies with AV limit, AV Result is deemed to comply with AV limit.  
 3. Test setup: RBW: 1 MHz, VBW: 3 MHz, Sweep time: auto.

# TR-4-E-009 Radiated Emission Test Result

<b>Test Site</b>	: DDT 3m Chamber 1#	D:\2017 RE1# Report Data\Q17112903-1E\Q17112904-1E
		FCC 1G-18G 5G WIFI .EM6
<b>Test Date</b>	: 2018-01-04	<b>Tested By</b> : Sunny
<b>EUT</b>	: Wireless speaker	<b>Model Number</b> : ALLURE PORTABLE
<b>Power Supply</b>	: AC 120V/60Hz	<b>Test Mode</b> : TX mode
<b>Condition</b>	: Temp:24.5'C,Humi:55%, Press:100.1kPa	<b>Antenna/Distance</b> : 2016 HF907/3m/HORIZONTAL
<b>Memo</b>	: 11a 5550MHz	

Data: 185

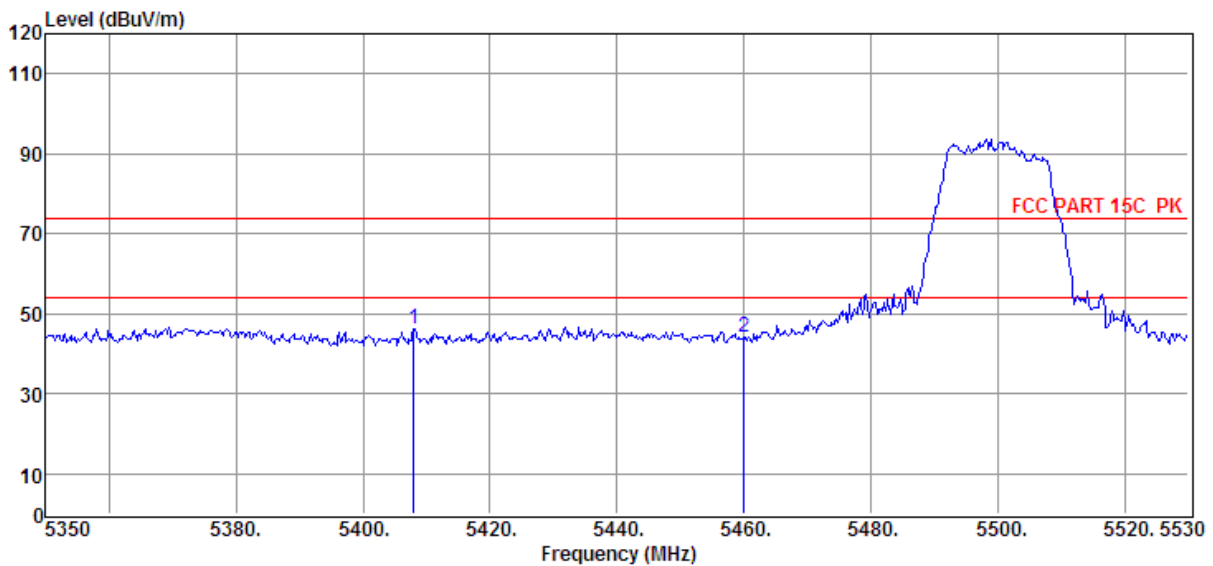

Item (Mark)	Freq. (MHz)	Read Level (dBµV)	Antenna Factor (dB/m)	PRM Facto r dB	Cable Loss dB	Result Level (dBµV/m)	Limit Line (dBµV/m)	Over Limit (dB)	Detector	Polarization
1	5407.96	32.25	35.49	29.29	7.84	46.29	74.00	-27.7 1	Peak	HORIZONTAL
2	5459.98	29.81	35.55	29.28	7.87	43.95	74.00	-30.0 5	Peak	HORIZONTAL

Note: 1. Result Level = Read Level + Antenna Factor + Cable loss - PRM Factor.  
 2. If Peak Result complies with AV limit, AV Result is deemed to comply with AV limit.  
 3. Test setup: RBW: 1 MHz, VBW: 3 MHz, Sweep time: auto.

# TR-4-E-009 Radiated Emission Test Result

<b>Test Site</b>	: DDT 3m Chamber 1#	<b>D:\2017 RE1# Report Data\Q17112903-1E\Q17112904-1E FCC 1G-18G 5G WIFI .EM6</b>
<b>Test Date</b>	: 2018-01-04	<b>Tested By</b> : Sunny
<b>EUT</b>	: Wireless speaker	<b>Model Number</b> : ALLURE PORTABLE
<b>Power Supply</b>	: AC 120V/60Hz	<b>Test Mode</b> : TX mode
<b>Condition</b>	: Temp:24.5'C,Humi:55%, Press:100.1kPa	<b>Antenna/Distance</b> : 2016 HF907/3m/VERTICAL
<b>Memo</b>	: 11a 5550MHz	

Data: 186

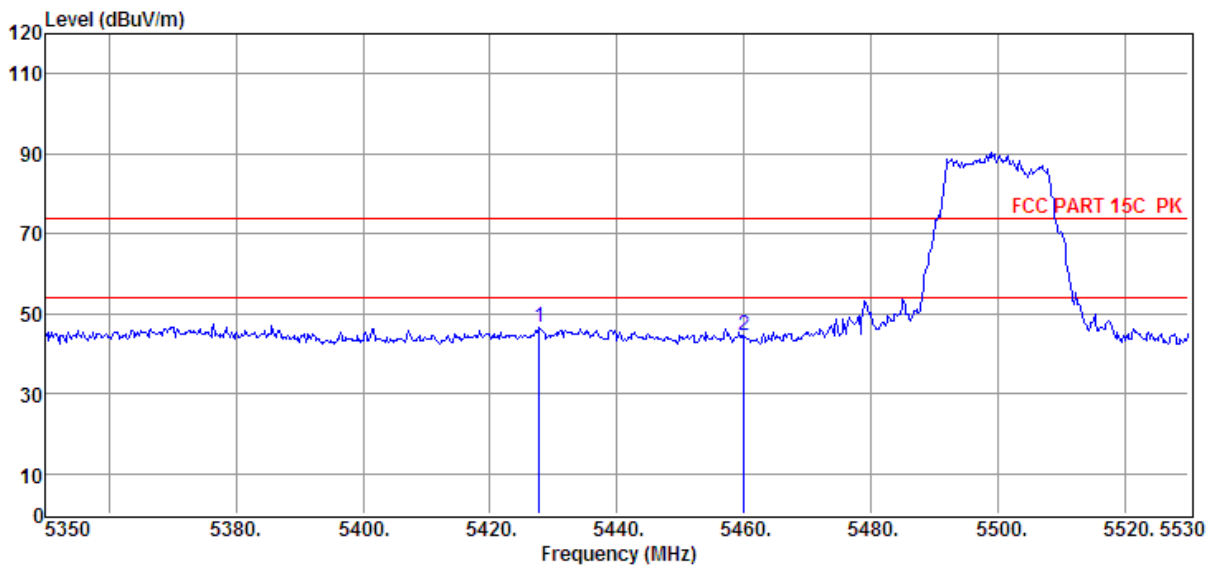

Item (Mark)	Freq. (MHz)	Read Level (dBμV)	Antenna Factor (dB/m)	PRM Factor (dB)	Cable Loss (dB)	Result Level (dBμV/m)	Limit Line (dBμV/m)	Over Limit (dB)	Detector	Polarization
1	5427.76	32.56	35.51	29.28	7.85	46.64	74.00	-27.36	Peak	VERTICAL
2	5459.98	30.20	35.55	29.28	7.87	44.34	74.00	-29.66	Peak	VERTICAL

- Note: 1. Result Level = Read Level + Antenna Factor + Cable loss - PRM Factor.  
 2. If Peak Result complies with AV limit, AV Result is deemed to comply with AV limit.  
 3. Test setup: RBW: 1 MHz, VBW: 3 MHz, Sweep time: auto.

# TR-4-E-009 Radiated Emission Test Result

<b>Test Site</b>	: DDT 3m Chamber 1#	D:\2017 RE1# Report Data\Q17112903-1E\Q17112904-1E FCC 1G-18G 5G WIFI .EM6
<b>Test Date</b>	: 2018-01-04	<b>Tested By</b> : Sunny
<b>EUT</b>	: Wireless speaker	<b>Model Number</b> : ALLURE PORTABLE
<b>Power Supply</b>	: AC 120V/60Hz	<b>Test Mode</b> : TX mode
<b>Condition</b>	: Temp:24.5'C,Humi:55%, Press:100.1kPa	<b>Antenna/Distance</b> : 2016 HF907/3m/HORIZONTAL
<b>Memo</b>	: 11a 5700MHz	

Data: 187

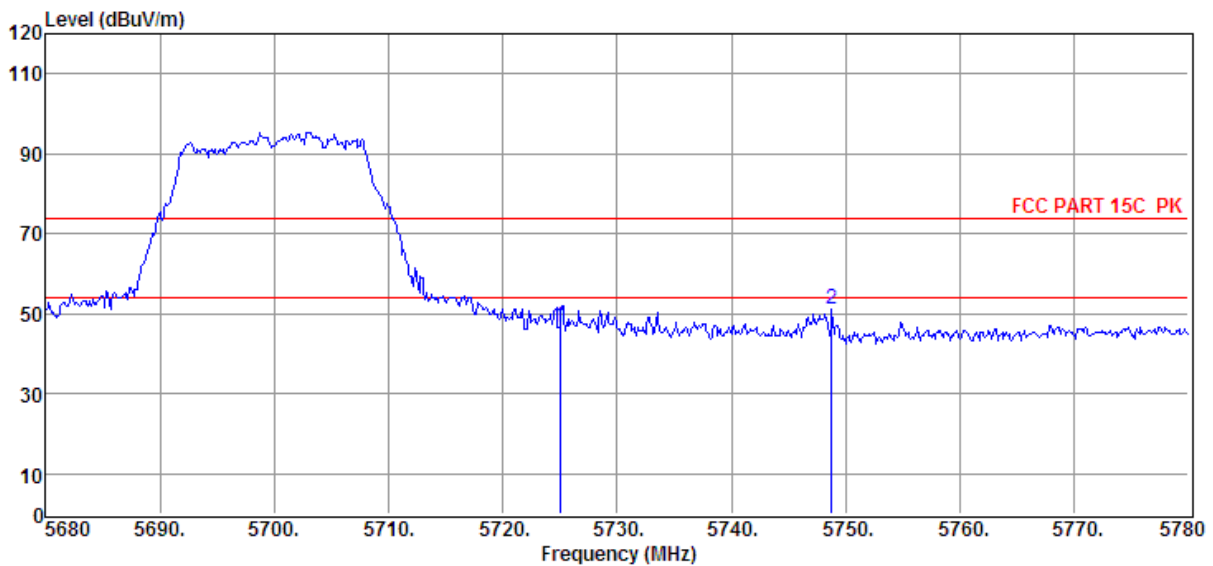

Item (Mark)	Freq. (MHz)	Read Level (dBµV)	Antenna Factor (dB/m)	PRM Facto r dB	Cable Loss dB	Result Level (dBµV/m)	Limit Line (dBµV/m)	Over Limit (dB)	Detector	Polarization
1	5725.00	32.12	35.69	29.22	8.04	46.63	74.00	-27.3 7	Peak	HORIZONTAL
2	5748.80	36.49	35.70	29.21	8.05	51.03	74.00	-22.9 7	Peak	HORIZONTAL

- Note: 1. Result Level = Read Level + Antenna Factor + Cable loss - PRM Factor.  
 2. If Peak Result complies with AV limit, AV Result is deemed to comply with AV limit.  
 3. Test setup: RBW: 1 MHz, VBW: 3 MHz, Sweep time: auto.

# TR-4-E-009 Radiated Emission Test Result

<b>Test Site</b>	: DDT 3m Chamber 1#	<b>D:\2017 RE1# Report Data\Q17112903-1E\Q17112904-1E</b>
		<b>FCC 1G-18G 5G WIFI .EM6</b>
<b>Test Date</b>	: 2018-01-04	<b>Tested By</b> : Sunny
<b>EUT</b>	: Wireless speaker	<b>Model Number</b> : ALLURE PORTABLE
<b>Power Supply</b>	: AC 120V/60Hz	<b>Test Mode</b> : TX mode
<b>Condition</b>	: Temp:24.5'C,Humi:55%, Press:100.1kPa	<b>Antenna/Distance</b> : 2016 HF907/3m/VERTICAL
<b>Memo</b>	: 11a 5700MHz	

Data: 188

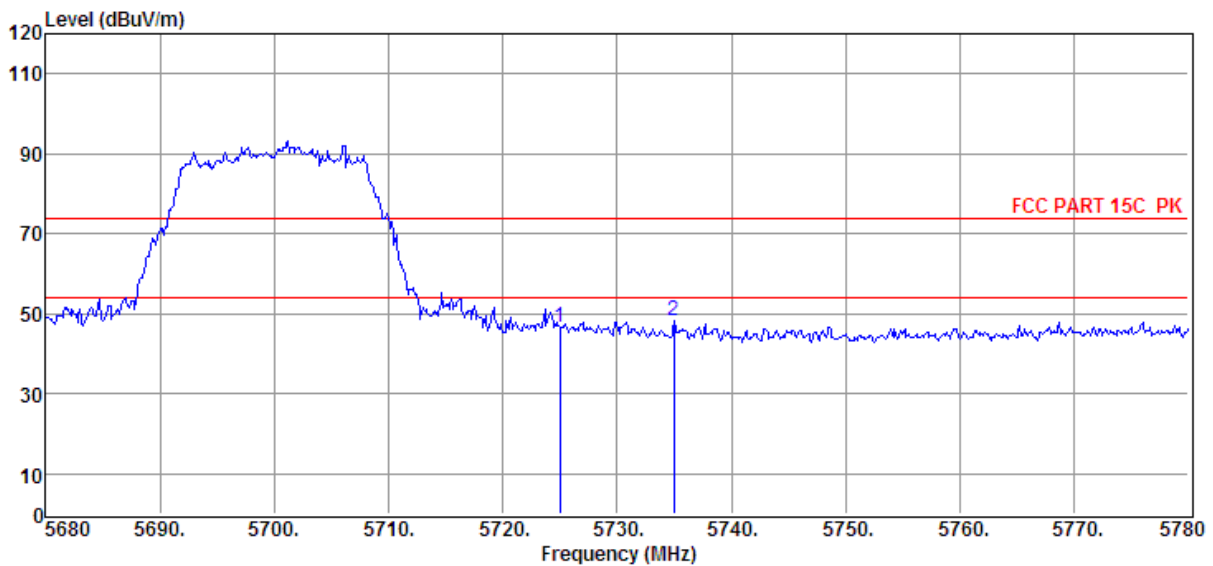

Item (Mark)	Freq. (MHz)	Read Level (dBμV)	Antenna Factor (dB/m)	PRM Facto r dB	Cable Loss dB	Result Level (dBμV/m)	Limit Line (dBμV/m)	Over Limit (dB)	Detector	Polarization
1	5725.00	32.12	35.69	29.22	8.04	46.63	74.00	-27.37	Peak	VERTICAL
2	5735.00	33.59	35.69	29.21	8.04	48.11	74.00	-25.89	Peak	VERTICAL

- Note: 1. Result Level = Read Level + Antenna Factor + Cable loss - PRM Factor.  
 2. If Peak Result complies with AV limit, AV Result is deemed to comply with AV limit.  
 3. Test setup: RBW: 1 MHz, VBW: 3 MHz, Sweep time: auto.

# TR-4-E-009 Radiated Emission Test Result

<b>Test Site</b>	: DDT 3m Chamber 1#	D:\2017 RE1# Report Data\Q17112903-1E\Q17112904-1E FCC 1G-18G 5G WIFI .EM6
<b>Test Date</b>	: 2018-01-04	<b>Tested By</b> : Sunny
<b>EUT</b>	: Wireless speaker	<b>Model Number</b> : ALLURE PORTABLE
<b>Power Supply</b>	: AC 120V/60Hz	<b>Test Mode</b> : TX mode
<b>Condition</b>	: Temp:24.5'C,Humi:55%, Press:100.1kPa	<b>Antenna/Distance</b> : 2016 HF907/3m/VERTICAL
<b>Memo</b>	: 11a 5745MHz	

Data: 189

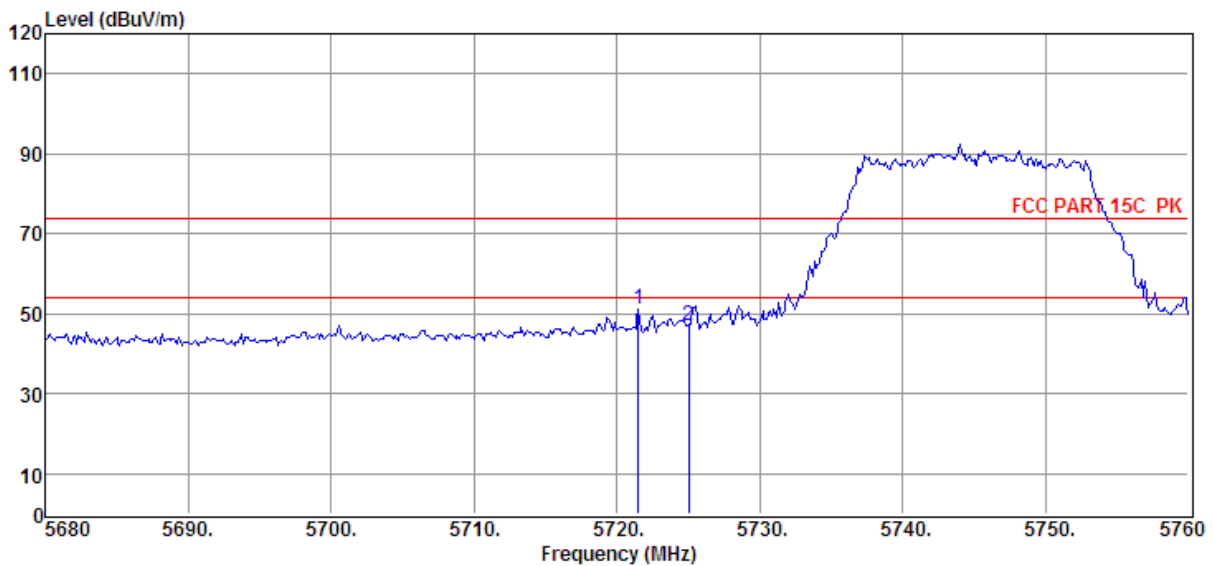

Item	Freq.	Read Level	Antenna Factor	PRM Factor	Cable Loss	Result Level	Limit Line	Over Limit	Detector	Polarization
(Mark)	(MHz)	(dBμV)	(dB/m)	dB	dB	(dBμV/m)	(dBμV/m)	(dB)		
1	5721.50	36.73	35.69	29.22	8.03	51.23	74.00	-22.77	Peak	VERTICAL
2	5725.00	32.45	35.69	29.22	8.04	46.96	74.00	-27.04	Peak	VERTICAL

Note: 1. Result Level = Read Level + Antenna Factor + Cable loss - PRM Factor.  
 2. If Peak Result complies with AV limit, AV Result is deemed to comply with AV limit.  
 3. Test setup: RBW: 1 MHz, VBW: 3 MHz, Sweep time: auto.

# TR-4-E-009 Radiated Emission Test Result

<b>Test Site</b>	: DDT 3m Chamber 1#	<b>D:\2017 RE1# Report Data\Q17112903-1E\Q17112904-1E FCC 1G-18G 5G WIFI .EM6</b>
<b>Test Date</b>	: 2018-01-04	<b>Tested By</b> : Sunny
<b>EUT</b>	: Wireless speaker	<b>Model Number</b> : ALLURE PORTABLE
<b>Power Supply</b>	: AC 120V/60Hz	<b>Test Mode</b> : TX mode
<b>Condition</b>	: Temp:24.5'C,Humi:55%, Press:100.1kPa	<b>Antenna/Distance</b> : 2016 HF907/3m/HORIZONTAL
<b>Memo</b>	: 11a 5745MHz	

Data: 190

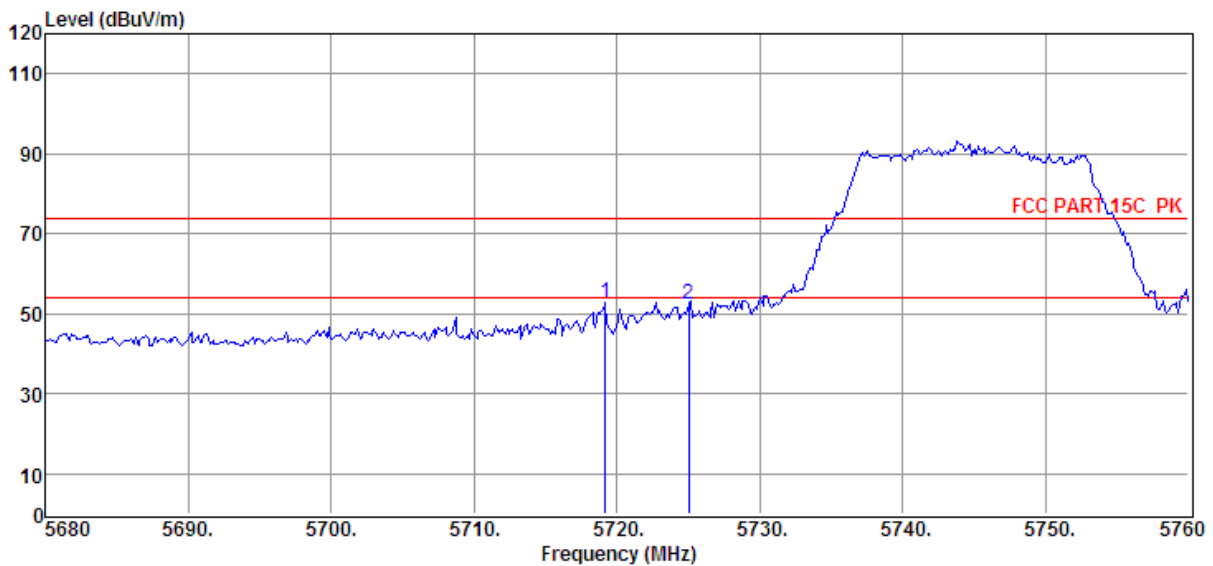

Item	Freq.	Read Level	Antenna Factor	PRM Factor	Cable Loss	Result Level	Limit Line	Over Limit	Detector	Polarization
(Mark)	(MHz)	(dBμV)	(dB/m)	dB	dB	(dBμV/m)	(dBμV/m)	(dB)		
1	5719.20	38.13	35.69	29.22	8.03	52.63	74.00	-21.37	Peak	HORIZONTAL
2	5725.00	37.93	35.69	29.22	8.04	52.44	74.00	-21.56	Peak	HORIZONTAL

- Note: 1. Result Level = Read Level + Antenna Factor + Cable loss - PRM Factor.  
 2. If Peak Result complies with AV limit, AV Result is deemed to comply with AV limit.  
 3. Test setup: RBW: 1 MHz, VBW: 3 MHz, Sweep time: auto.

# TR-4-E-009 Radiated Emission Test Result

<b>Test Site</b>	: DDT 3m Chamber 1#	D:\2017 RE1# Report Data\Q17112903-1E\Q17112904-1E FCC 1G-18G 5G WIFI .EM6
<b>Test Date</b>	: 2018-01-04	<b>Tested By</b> : Sunny
<b>EUT</b>	: Wireless speaker	<b>Model Number</b> : ALLURE PORTABLE
<b>Power Supply</b>	: AC 120V/60Hz	<b>Test Mode</b> : TX mode
<b>Condition</b>	: Temp:24.5'C,Humi:55%, Press:100.1kPa	<b>Antenna/Distance</b> : 2016 HF907/3m/VERTICAL
<b>Memo</b>	: 11a 5825MHz	

Data: 191

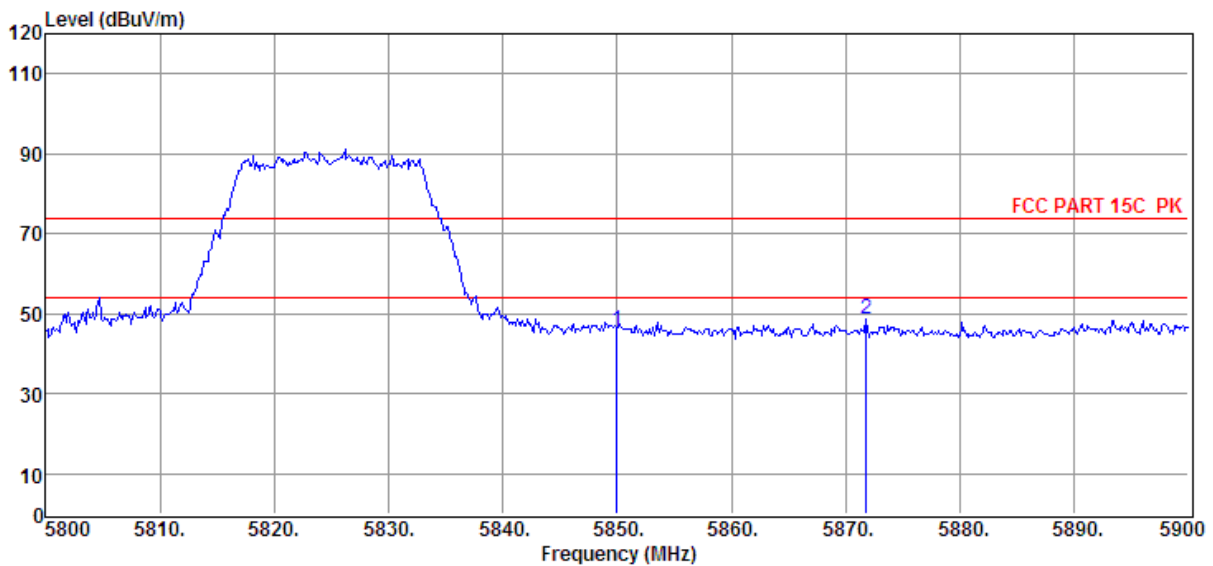

Item (Mark)	Freq. (MHz)	Read Level (dBµV)	Antenna Factor (dB/m)	PRM Facto r dB	Cable Loss dB	Result Level (dBµV/m)	Limit Line (dBµV/m)	Over Limit (dB)	Detector	Polarization
1	5850.00	31.28	35.74	29.20	8.12	45.94	74.00	-28.06	Peak	VERTICAL
2	5871.80	33.98	35.75	29.20	8.13	48.66	74.00	-25.34	Peak	VERTICAL

Note: 1. Result Level = Read Level + Antenna Factor + Cable loss - PRM Factor.  
 2. If Peak Result complies with AV limit, AV Result is deemed to comply with AV limit.  
 3. Test setup: RBW: 1 MHz, VBW: 3 MHz, Sweep time: auto.

# TR-4-E-009 Radiated Emission Test Result

<b>Test Site</b>	: DDT 3m Chamber 1#	D:\2017 RE1# Report Data\Q17112903-1E\Q17112904-1E
		FCC 1G-18G 5G WIFI .EM6
<b>Test Date</b>	: 2018-01-04	<b>Tested By</b> : Sunny
<b>EUT</b>	: Wireless speaker	<b>Model Number</b> : ALLURE PORTABLE
<b>Power Supply</b>	: AC 120V/60Hz	<b>Test Mode</b> : TX mode
<b>Condition</b>	: Temp:24.5'C,Humi:55%, Press:100.1kPa	<b>Antenna/Distance</b> : 2016 HF907/3m/HORIZONTAL
<b>Memo</b>	: 11a 5825MHz	

Data: 192

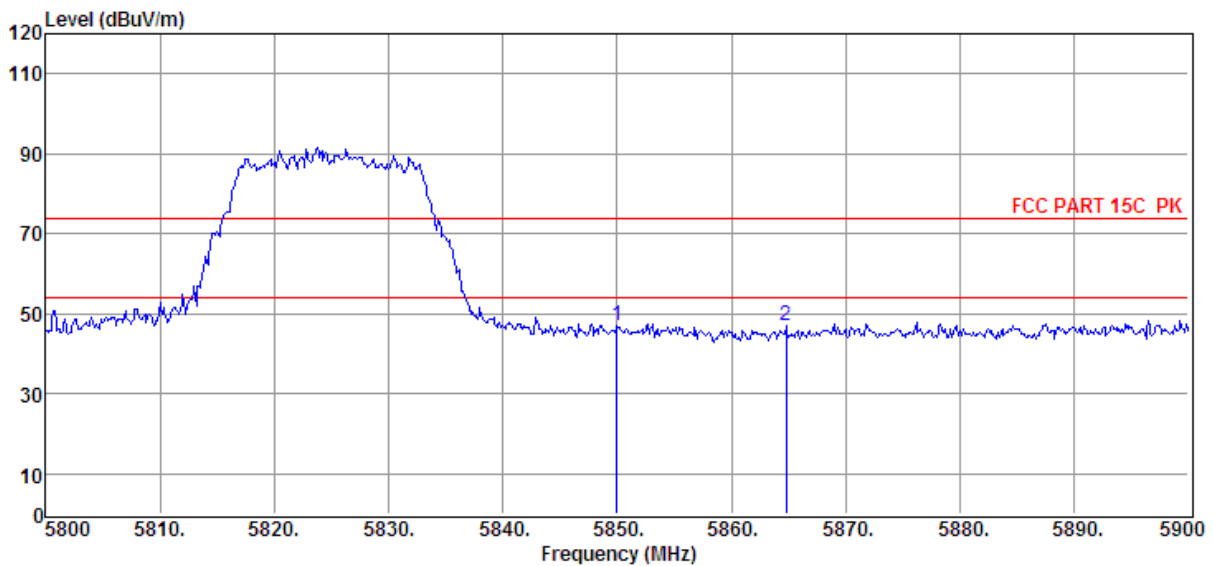

Item (Mark)	Freq. (MHz)	Read Level (dBμV)	Antenna Factor (dB/m)	PRM Factor (dB)	Cable Loss (dB)	Result Level (dBμV/m)	Limit Line (dBμV/m)	Over Limit (dB)	Detector	Polarization
1	5850.00	32.31	35.74	29.20	8.12	46.97	74.00	-27.03	Peak	HORIZONTAL
2	5864.80	32.53	35.75	29.20	8.12	47.20	74.00	-26.80	Peak	HORIZONTAL

Note: 1. Result Level = Read Level + Antenna Factor + Cable loss - PRM Factor.  
 2. If Peak Result complies with AV limit, AV Result is deemed to comply with AV limit.  
 3. Test setup: RBW: 1 MHz, VBW: 3 MHz, Sweep time: auto.

# TR-4-E-009 Radiated Emission Test Result

<b>Test Site</b>	: DDT 3m Chamber 1#	D:\2017 RE1# Report Data\Q17112903-1E\Q17112904-1E FCC 1G-18G 5G WIFI .EM6
<b>Test Date</b>	: 2018-01-04	<b>Tested By</b> : Sunny
<b>EUT</b>	: Wireless speaker	<b>Model Number</b> : ALLURE PORTABLE
<b>Power Supply</b>	: AC 120V/60Hz	<b>Test Mode</b> : TX mode
<b>Condition</b>	: Temp:24.5'C,Humi:55%, Press:100.1kPa	<b>Antenna/Distance</b> : 2016 HF907/3m/HORIZONTAL
<b>Memo</b>	: 11n20 5180MHz	

Data: 193

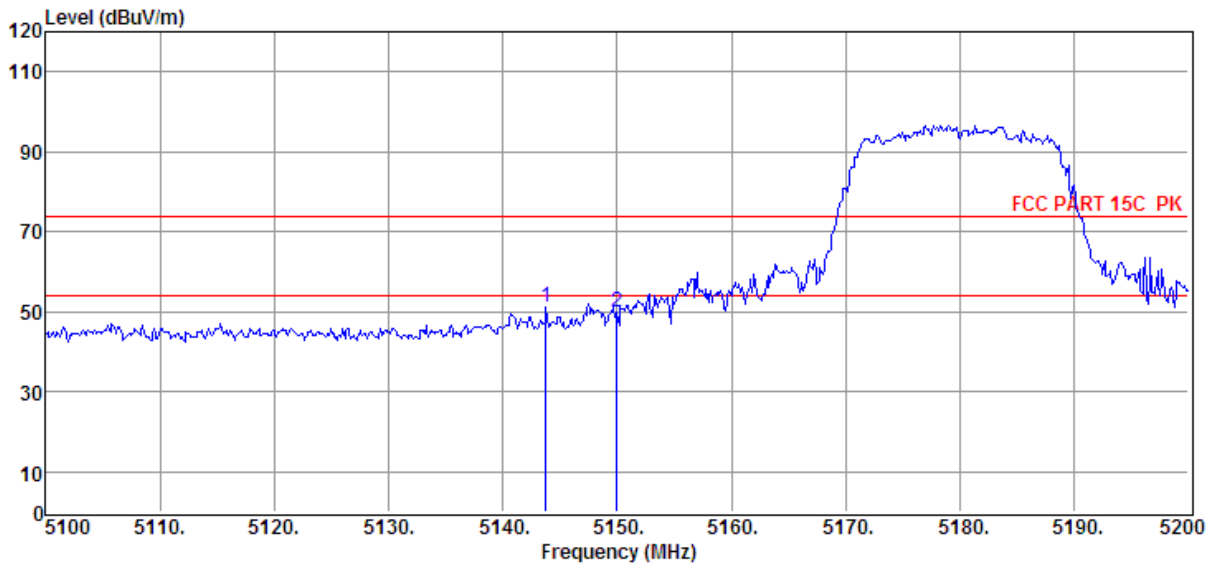

Item	Freq.	Read Level	Antenna Factor	PRM Factor	Cable Loss	Result Level	Limit Line	Over Limit	Detector	Polarization
(Mark)	(MHz)	(dBμV)	(dB/m)	dB	dB	(dBμV/m)	(dBμV/m)	(dB)		
1	5143.80	37.63	35.17	29.33	7.67	51.14	74.00	-22.86	Peak	HORIZONTAL
2	5150.00	36.53	35.18	29.33	7.67	50.05	74.00	-23.95	Peak	HORIZONTAL

Note: 1. Result Level = Read Level + Antenna Factor + Cable loss - PRM Factor.  
 2. If Peak Result complies with AV limit, AV Result is deemed to comply with AV limit.  
 3. Test setup: RBW: 1 MHz, VBW: 3 MHz, Sweep time: auto.

# TR-4-E-009 Radiated Emission Test Result

<b>Test Site</b>	: DDT 3m Chamber 1#	D:\2017 RE1# Report Data\Q17112903-1E\Q17112904-1E FCC 1G-18G 5G WIFI .EM6
<b>Test Date</b>	: 2018-01-04	<b>Tested By</b> : Sunny
<b>EUT</b>	: Wireless speaker	<b>Model Number</b> : ALLURE PORTABLE
<b>Power Supply</b>	: AC 120V/60Hz	<b>Test Mode</b> : TX mode
<b>Condition</b>	: Temp:24.5'C,Humi:55%, Press:100.1kPa	<b>Antenna/Distance</b> : 2016 HF907/3m/VERTICAL
<b>Memo</b>	: 11n20 5180MHz	

Data: 194

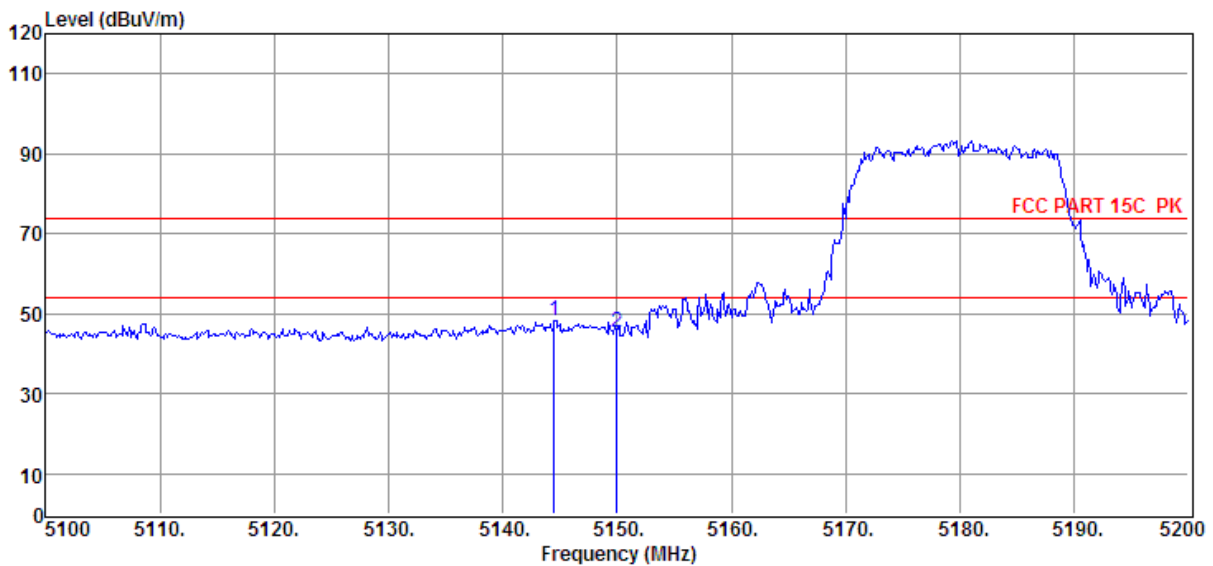

Item	Freq.	Read Level	Antenna Factor	PRM Factor	Cable Loss	Result Level	Limit Line	Over Limit	Detector	Polarization
(Mark)	(MHz)	(dBμV)	(dB/m)	dB	dB	(dBμV/m)	(dBμV/m)	(dB)		
1	5144.50	34.89	35.17	29.33	7.67	48.40	74.00	-25.60	Peak	VERTICAL
2	5150.00	31.96	35.18	29.33	7.67	45.48	74.00	-28.52	Peak	VERTICAL

- Note: 1. Result Level = Read Level + Antenna Factor + Cable loss - PRM Factor.  
 2. If Peak Result complies with AV limit, AV Result is deemed to comply with AV limit.  
 3. Test setup: RBW: 1 MHz, VBW: 3 MHz, Sweep time: auto.

# TR-4-E-009 Radiated Emission Test Result

<b>Test Site</b>	: DDT 3m Chamber 1#	D:\2017 RE1# Report Data\Q17112903-1E\Q17112904-1E FCC 1G-18G 5G WIFI .EM6
<b>Test Date</b>	: 2018-01-04	<b>Tested By</b> : Sunny
<b>EUT</b>	: Wireless speaker	<b>Model Number</b> : ALLURE PORTABLE
<b>Power Supply</b>	: AC 120V/60Hz	<b>Test Mode</b> : TX mode
<b>Condition</b>	: Temp:24.5'C,Humi:55%, Press:100.1kPa	<b>Antenna/Distance</b> : 2016 HF907/3m/HORIZONTAL
<b>Memo</b>	: 11n20 5240MHz	

Data: 195

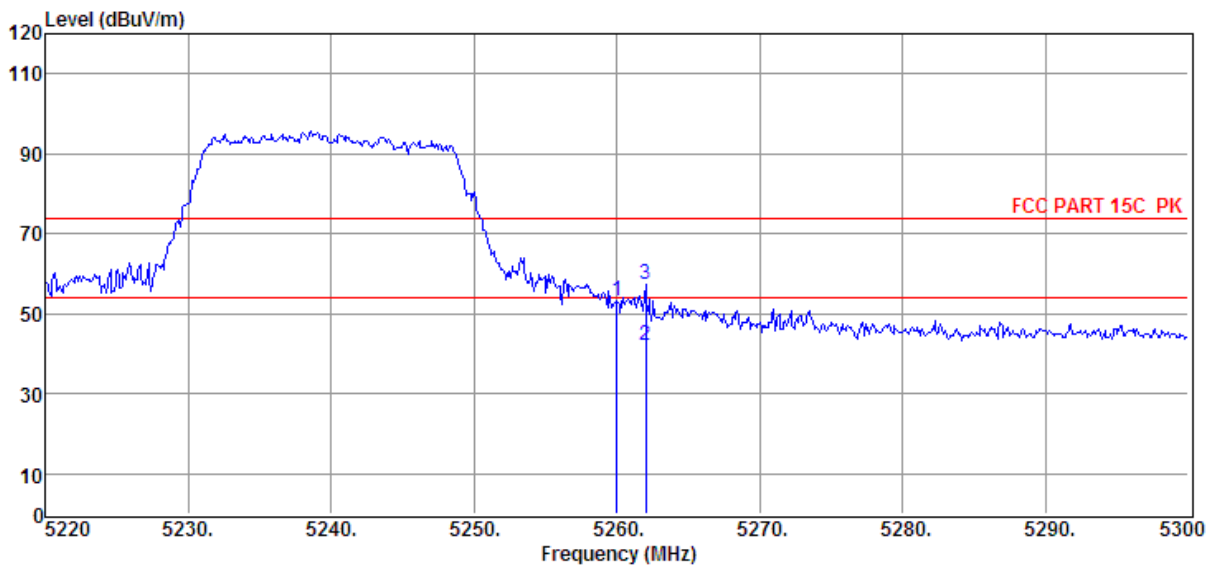

Item (Mark)	Freq. (MHz)	Read Level (dBµV)	Antenna Factor (dB/m)	PRM Facto r dB	Cable Loss dB	Result Level (dBµV/m)	Limit Line (dBµV/m)	Over Limit (dB)	Detector	Polarization
1	5260.00	39.61	35.31	29.32	7.74	53.34	74.00	-20.6 6	Peak	HORIZONTAL
2	5262.00	28.48	35.31	29.32	7.75	42.22	54.00	-11.7 8	Average	HORIZONTAL
3	5262.00	43.48	35.31	29.32	7.75	57.22	74.00	-16.7 8	Peak	HORIZONTAL

- Note: 1. Result Level = Read Level + Antenna Factor + Cable loss - PRM Factor.  
 2. If Peak Result complies with AV limit, AV Result is deemed to comply with AV limit.  
 3. Test setup: RBW: 1 MHz, VBW: 3 MHz, Sweep time: auto.

# TR-4-E-009 Radiated Emission Test Result

<b>Test Site</b>	: DDT 3m Chamber 1#	D:\2017 RE1# Report Data\Q17112903-1E\Q17112904-1E FCC 1G-18G 5G WIFI .EM6
<b>Test Date</b>	: 2018-01-04	<b>Tested By</b> : Sunny
<b>EUT</b>	: Wireless speaker	<b>Model Number</b> : ALLURE PORTABLE
<b>Power Supply</b>	: AC 120V/60Hz	<b>Test Mode</b> : TX mode
<b>Condition</b>	: Temp:24.5'C,Humi:55%, Press:100.1kPa	<b>Antenna/Distance</b> : 2016 HF907/3m/VERTICAL
<b>Memo</b>	: 11n20 5240MHz	

Data: 196

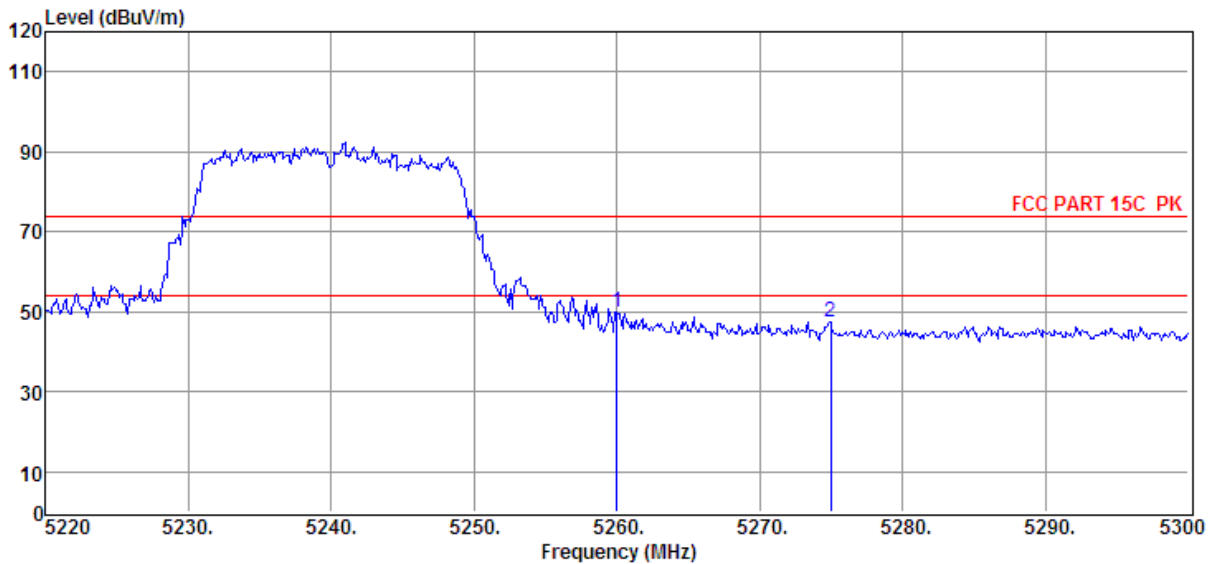

Item	Freq.	Read Level	Antenna Factor	PRM Factor	Cable Loss	Result Level	Limit Line	Over Limit	Detector	Polarization
(Mark)	(MHz)	(dBμV)	(dB/m)	dB	dB	(dBμV/m)	(dBμV/m)	(dB)		
1	5260.00	36.14	35.31	29.32	7.74	49.87	74.00	-24.13	Peak	VERTICAL
2	5274.96	33.67	35.33	29.31	7.75	47.44	74.00	-26.56	Peak	VERTICAL

Note: 1. Result Level = Read Level + Antenna Factor + Cable loss - PRM Factor.  
 2. If Peak Result complies with AV limit, AV Result is deemed to comply with AV limit.  
 3. Test setup: RBW: 1 MHz, VBW: 3 MHz, Sweep time: auto.

# TR-4-E-009 Radiated Emission Test Result

<b>Test Site</b>	: DDT 3m Chamber 1#	D:\2017 RE1# Report Data\Q17112903-1E\Q17112904-1E
		FCC 1G-18G 5G WIFI .EM6
<b>Test Date</b>	: 2018-01-04	<b>Tested By</b> : Sunny
<b>EUT</b>	: Wireless speaker	<b>Model Number</b> : ALLURE PORTABLE
<b>Power Supply</b>	: AC 120V/60Hz	<b>Test Mode</b> : TX mode
<b>Condition</b>	: Temp:24.5'C,Humi:55%, Press:100.1kPa	<b>Antenna/Distance</b> : 2016 HF907/3m/HORIZONTAL
<b>Memo</b>	: 11n20 5260MHz	

Data: 197

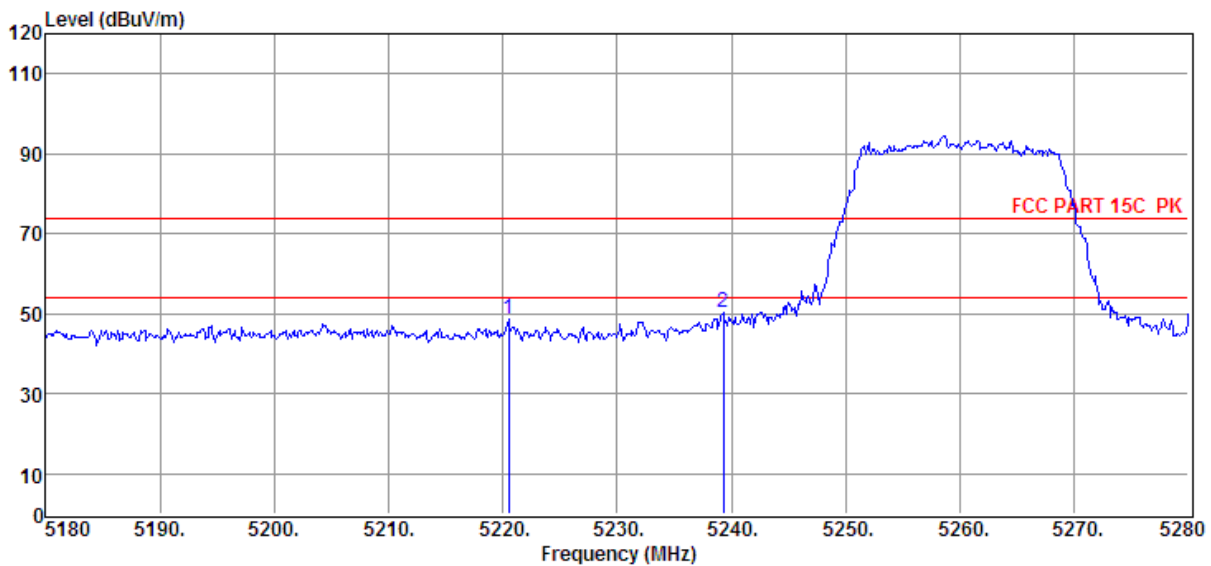

Item	Freq.	Read Level	Antenna Factor	PRM Factor	Cable Loss	Result Level	Limit Line	Over Limit	Detector	Polarization
(Mark)	(MHz)	(dBμV)	(dB/m)	dB	dB	(dBμV/m)	(dBμV/m)	(dB)		
1	5220.50	34.94	35.26	29.33	7.72	48.59	74.00	-25.4 1	Peak	HORIZONTAL
2	5239.30	36.44	35.29	29.32	7.73	50.14	74.00	-23.8 6	Peak	HORIZONTAL

Note: 1. Result Level = Read Level + Antenna Factor + Cable loss - PRM Factor.  
 2. If Peak Result complies with AV limit, AV Result is deemed to comply with AV limit.  
 3. Test setup: RBW: 1 MHz, VBW: 3 MHz, Sweep time: auto.

# TR-4-E-009 Radiated Emission Test Result

<b>Test Site</b>	: DDT 3m Chamber 1#	D:\2017 RE1# Report Data\Q17112903-1E\Q17112904-1E
		FCC 1G-18G 5G WIFI .EM6
<b>Test Date</b>	: 2018-01-04	<b>Tested By</b> : Sunny
<b>EUT</b>	: Wireless speaker	<b>Model Number</b> : ALLURE PORTABLE
<b>Power Supply</b>	: AC 120V/60Hz	<b>Test Mode</b> : TX mode
<b>Condition</b>	: Temp:24.5'C,Humi:55%, Press:100.1kPa	<b>Antenna/Distance</b> : 2016 HF907/3m/VERTICAL
<b>Memo</b>	: 11n20 5260MHz	

Data: 198

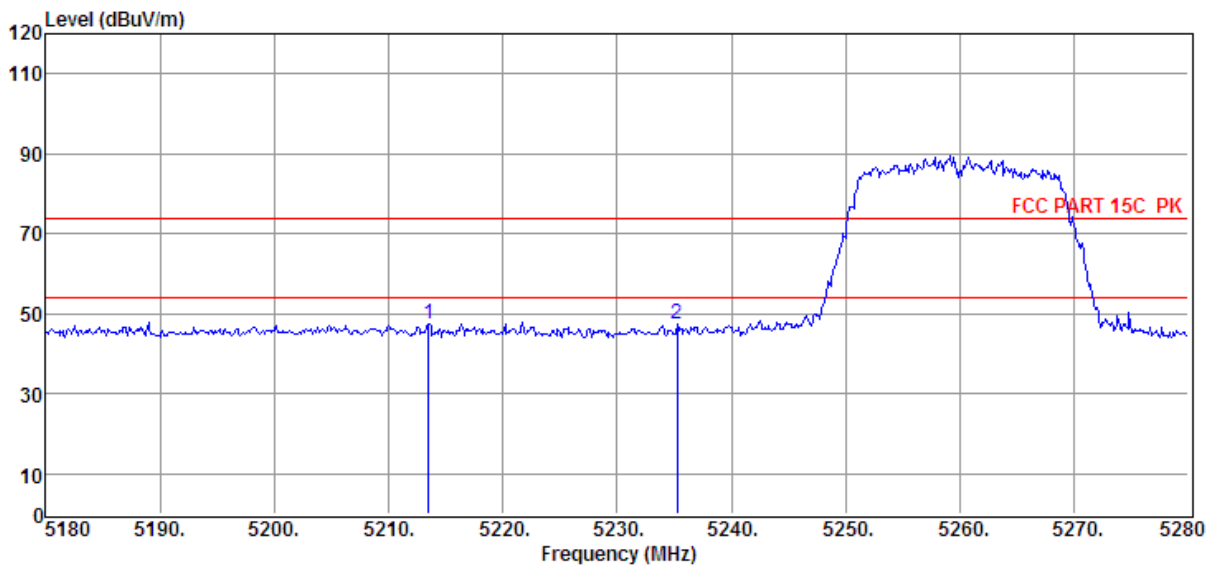

Item	Freq.	Read Level	Antenna Factor	PRM Factor	Cable Loss	Result Level	Limit Line	Over Limit	Detector	Polarization
(Mark)	(MHz)	(dBμV)	(dB/m)	dB	dB	(dBμV/m)	(dBμV/m)	(dB)		
1	5213.50	33.70	35.26	29.33	7.71	47.34	74.00	-26.66	Peak	VERTICAL
2	5235.30	33.56	35.28	29.32	7.73	47.25	74.00	-26.75	Peak	VERTICAL

Note: 1. Result Level = Read Level + Antenna Factor + Cable loss - PRM Factor.  
 2. If Peak Result complies with AV limit, AV Result is deemed to comply with AV limit.  
 3. Test setup: RBW: 1 MHz, VBW: 3 MHz, Sweep time: auto.

# TR-4-E-009 Radiated Emission Test Result

<b>Test Site</b>	: DDT 3m Chamber 1#	D:\2017 RE1# Report Data\Q17112903-1E\Q17112904-1E
		FCC 1G-18G 5G WIFI .EM6
<b>Test Date</b>	: 2018-01-04	<b>Tested By</b> : Sunny
<b>EUT</b>	: Wireless speaker	<b>Model Number</b> : ALLURE PORTABLE
<b>Power Supply</b>	: AC 120V/60Hz	<b>Test Mode</b> : TX mode
<b>Condition</b>	: Temp:24.5'C,Humi:55%, Press:100.1kPa	<b>Antenna/Distance</b> : 2016 HF907/3m/HORIZONTAL
<b>Memo</b>	: 11n20 5320MHz	

Data: 199

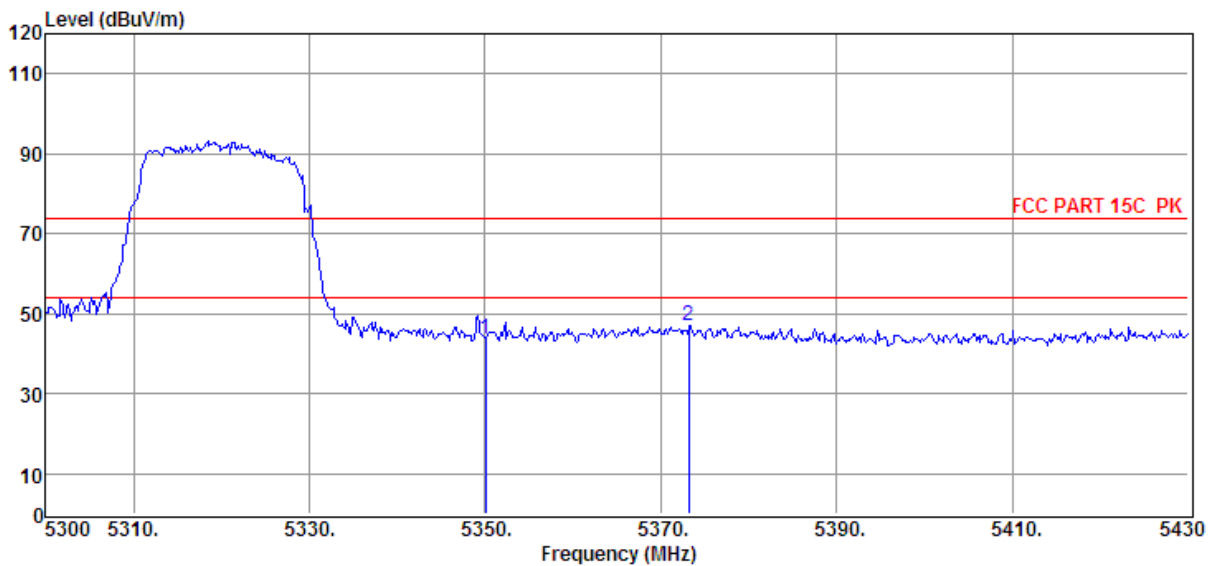

Item	Freq.	Read Level	Antenna Factor	PRM Factor	Cable Loss	Result Level	Limit Line	Over Limit	Detector	Polarization
(Mark)	(MHz)	(dBμV)	(dB/m)	dB	dB	(dBμV/m)	(dBμV/m)	(dB)		
1	5350.05	29.67	35.42	29.30	7.80	43.59	74.00	-30.41	Peak	HORIZONTAL
2	5373.19	33.05	35.45	29.30	7.82	47.02	74.00	-26.98	Peak	HORIZONTAL

- Note: 1. Result Level = Read Level + Antenna Factor + Cable loss - PRM Factor.  
 2. If Peak Result complies with AV limit, AV Result is deemed to comply with AV limit.  
 3. Test setup: RBW: 1 MHz, VBW: 3 MHz, Sweep time: auto.

# TR-4-E-009 Radiated Emission Test Result

<b>Test Site</b>	: DDT 3m Chamber 1#	D:\2017 RE1# Report Data\Q17112903-1E\Q17112904-1E FCC 1G-18G 5G WIFI .EM6
<b>Test Date</b>	: 2018-01-04	<b>Tested By</b> : Sunny
<b>EUT</b>	: Wireless speaker	<b>Model Number</b> : ALLURE PORTABLE
<b>Power Supply</b>	: AC 120V/60Hz	<b>Test Mode</b> : TX mode
<b>Condition</b>	: Temp:24.5'C,Humi:55%, Press:100.1kPa	<b>Antenna/Distance</b> : 2016 HF907/3m/VERTICAL
<b>Memo</b>	: 11n20 5320MHz	

Data: 200

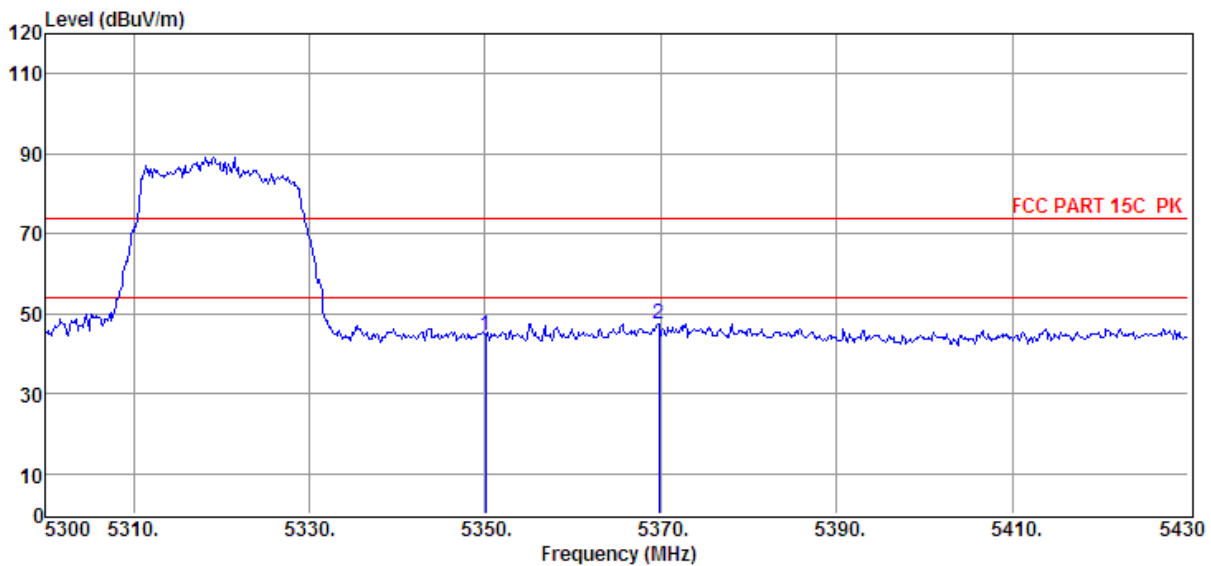

Item (Mark)	Freq. (MHz)	Read Level (dBμV)	Antenna Factor (dB/m)	PRM Facto r dB	Cable Loss dB	Result Level (dBμV/m)	Limit Line (dBμV/m)	Over Limit (dB)	Detector	Polarization
1	5350.05	30.52	35.42	29.30	7.80	44.44	74.00	-29.56	Peak	VERTICAL
2	5369.81	33.66	35.44	29.30	7.81	47.61	74.00	-26.39	Peak	VERTICAL

- Note: 1. Result Level = Read Level + Antenna Factor + Cable loss - PRM Factor.  
 2. If Peak Result complies with AV limit, AV Result is deemed to comply with AV limit.  
 3. Test setup: RBW: 1 MHz, VBW: 3 MHz, Sweep time: auto.

# TR-4-E-009 Radiated Emission Test Result

<b>Test Site</b>	: DDT 3m Chamber 1#	D:\2017 RE1# Report Data\Q17112903-1E\Q17112904-1E FCC 1G-18G 5G WIFI .EM6
<b>Test Date</b>	: 2018-01-04	<b>Tested By</b> : Sunny
<b>EUT</b>	: Wireless speaker	<b>Model Number</b> : ALLURE PORTABLE
<b>Power Supply</b>	: AC 120V/60Hz	<b>Test Mode</b> : TX mode
<b>Condition</b>	: Temp:24.5'C,Humi:55%, Press:100.1kPa	<b>Antenna/Distance</b> : 2016 HF907/3m/VERTICAL
<b>Memo</b>	: 11n20 5500MHz	

Data: 201

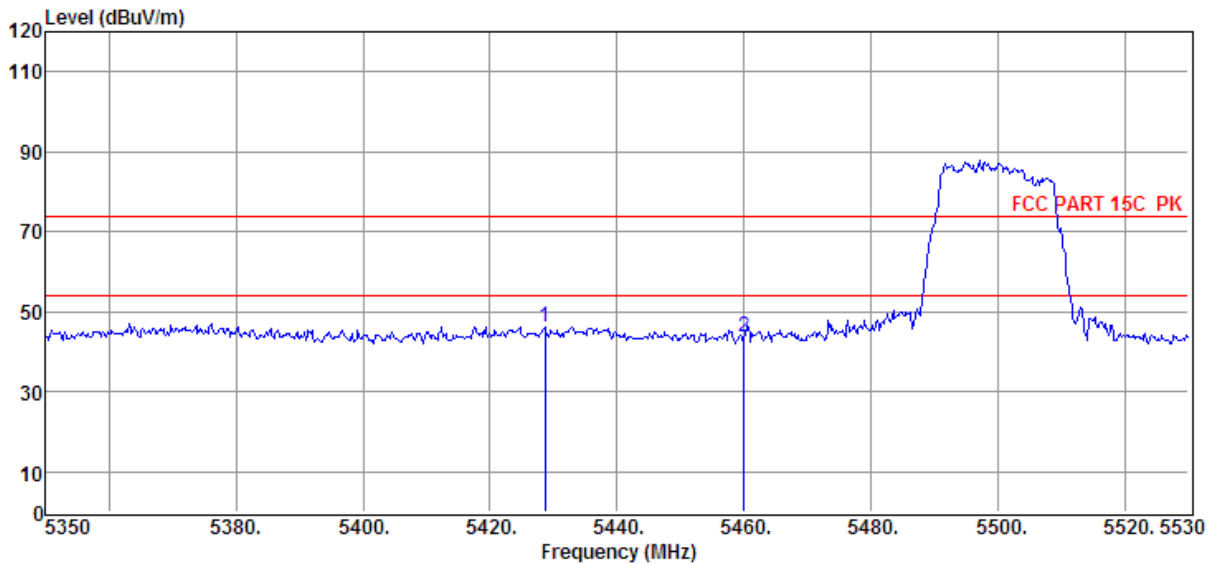

Item	Freq.	Read Level	Antenna Factor	PRM Factor	Cable Loss	Result Level	Limit Line	Over Limit	Detector	Polarization
(Mark)	(MHz)	(dBμV)	(dB/m)	dB	dB	(dBμV/m)	(dBμV/m)	(dB)		
1	5428.66	32.18	35.51	29.28	7.85	46.26	74.00	-27.74	Peak	VERTICAL
2	5459.98	29.45	35.55	29.28	7.87	43.59	74.00	-30.41	Peak	VERTICAL

Note: 1. Result Level = Read Level + Antenna Factor + Cable loss - PRM Factor.  
 2. If Peak Result complies with AV limit, AV Result is deemed to comply with AV limit.  
 3. Test setup: RBW: 1 MHz, VBW: 3 MHz, Sweep time: auto.

# TR-4-E-009 Radiated Emission Test Result

<b>Test Site</b>	: DDT 3m Chamber 1#	D:\2017 RE1# Report Data\Q17112903-1E\Q17112904-1E FCC 1G-18G 5G WIFI .EM6
<b>Test Date</b>	: 2018-01-04	<b>Tested By</b> : Sunny
<b>EUT</b>	: Wireless speaker	<b>Model Number</b> : ALLURE PORTABLE
<b>Power Supply</b>	: AC 120V/60Hz	<b>Test Mode</b> : TX mode
<b>Condition</b>	: Temp:24.5'C,Humi:55%, Press:100.1kPa	<b>Antenna/Distance</b> : 2016 HF907/3m/HORIZONTAL
<b>Memo</b>	: 11n20 5500MHz	

Data: 202

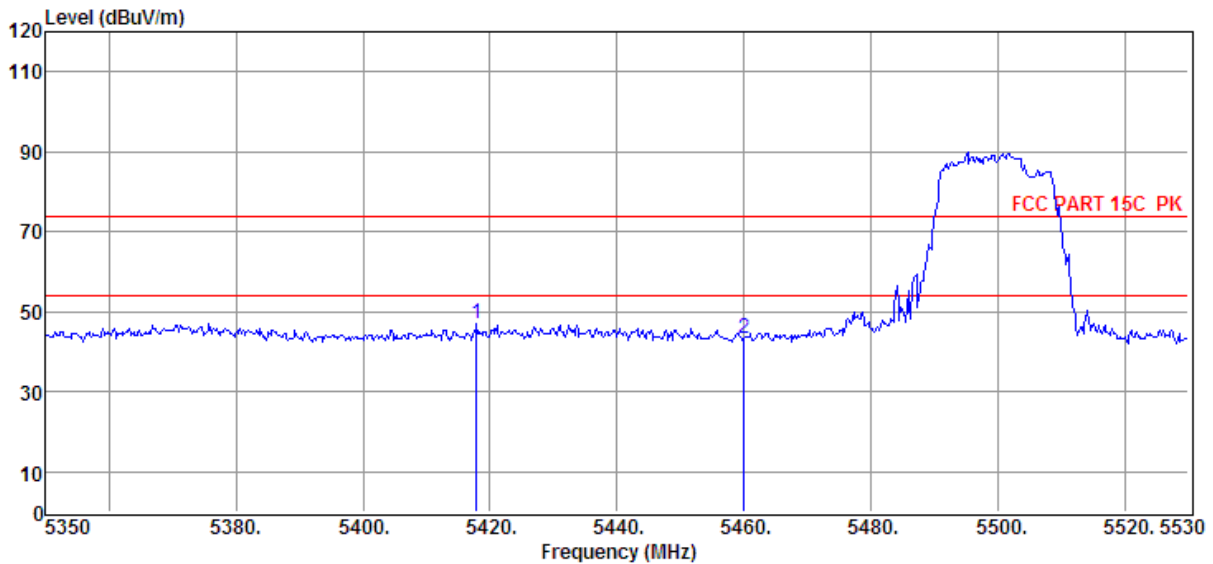

Item (Mark)	Freq. (MHz)	Read Level (dBμV)	Antenna Factor (dB/m)	PRM Facto r dB	Cable Loss dB	Result Level (dBμV/m)	Limit Line (dBμV/m)	Over Limit (dB)	Detector	Polarization
1	5417.86	32.76	35.50	29.28	7.84	46.82	74.00	-27.18	Peak	HORIZONTAL
2	5459.98	29.19	35.55	29.28	7.87	43.33	74.00	-30.67	Peak	HORIZONTAL

- Note: 1. Result Level = Read Level + Antenna Factor + Cable loss - PRM Factor.  
 2. If Peak Result complies with AV limit, AV Result is deemed to comply with AV limit.  
 3. Test setup: RBW: 1 MHz, VBW: 3 MHz, Sweep time: auto.

# TR-4-E-009 Radiated Emission Test Result

<b>Test Site</b>	: DDT 3m Chamber 1#	<b>D:\2017 RE1# Report Data\Q17112903-1E\Q17112904-1E FCC 1G-18G 5G WIFI .EM6</b>
<b>Test Date</b>	: 2018-01-04	<b>Tested By</b> : Sunny
<b>EUT</b>	: Wireless speaker	<b>Model Number</b> : ALLURE PORTABLE
<b>Power Supply</b>	: AC 120V/60Hz	<b>Test Mode</b> : TX mode
<b>Condition</b>	: Temp:24.5'C,Humi:55%, Press:100.1kPa	<b>Antenna/Distance</b> : 2016 HF907/3m/VERTICAL
<b>Memo</b>	: 11n20 5700MHz	

Data: 203

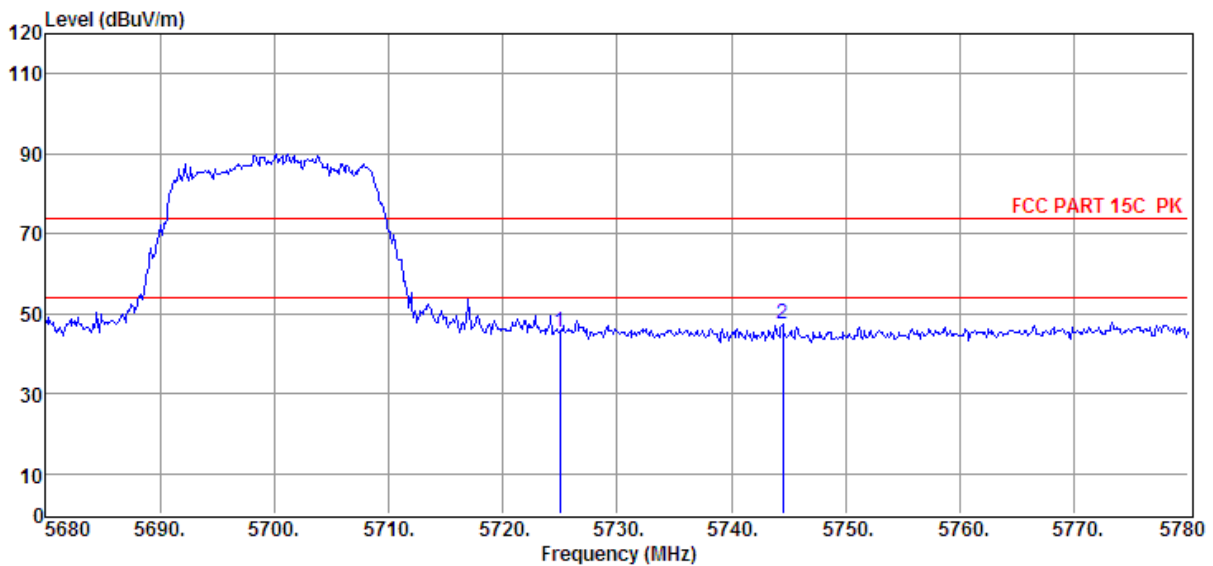

Item (Mark)	Freq. (MHz)	Read Level (dBμV)	Antenna Factor (dB/m)	PRM Factor (dB)	Cable Loss (dB)	Result Level (dBμV/m)	Limit Line (dBμV/m)	Over Limit (dB)	Detector	Polarization
1	5725.00	30.74	35.69	29.22	8.04	45.25	74.00	-28.75	Peak	VERTICAL
2	5744.50	33.06	35.70	29.21	8.05	47.60	74.00	-26.40	Peak	VERTICAL

Note: 1. Result Level = Read Level + Antenna Factor + Cable loss - PRM Factor.  
 2. If Peak Result complies with AV limit, AV Result is deemed to comply with AV limit.  
 3. Test setup: RBW: 1 MHz, VBW: 3 MHz, Sweep time: auto.

# TR-4-E-009 Radiated Emission Test Result

<b>Test Site</b>	: DDT 3m Chamber 1#	D:\2017 RE1# Report Data\Q17112903-1E\Q17112904-1E FCC 1G-18G 5G WIFI .EM6
<b>Test Date</b>	: 2018-01-04	<b>Tested By</b> : Sunny
<b>EUT</b>	: Wireless speaker	<b>Model Number</b> : ALLURE PORTABLE
<b>Power Supply</b>	: AC 120V/60Hz	<b>Test Mode</b> : TX mode
<b>Condition</b>	: Temp:24.5'C,Humi:55%, Press:100.1kPa	<b>Antenna/Distance</b> : 2016 HF907/3m/HORIZONTAL
<b>Memo</b>	: 11n20 5700MHz	

Data: 204

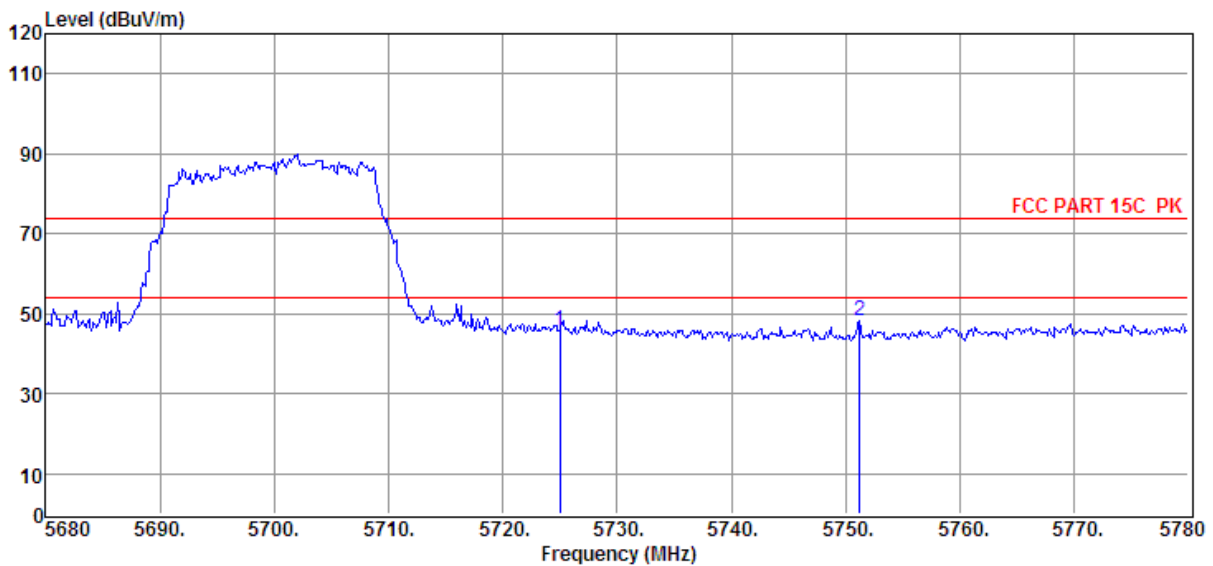

Item (Mark)	Freq. (MHz)	Read Level (dBμV)	Antenna Factor (dB/m)	PRM Facto r dB	Cable Loss dB	Result Level (dBμV/m)	Limit Line (dBμV/m)	Over Limit (dB)	Detector	Polarization
1	5725.00	31.28	35.69	29.22	8.04	45.79	74.00	-28.2 1	Peak	HORIZONTAL
2	5751.20	33.52	35.70	29.21	8.05	48.06	74.00	-25.9 4	Peak	HORIZONTAL

Note: 1. Result Level = Read Level + Antenna Factor + Cable loss - PRM Factor.  
 2. If Peak Result complies with AV limit, AV Result is deemed to comply with AV limit.  
 3. Test setup: RBW: 1 MHz, VBW: 3 MHz, Sweep time: auto.

# TR-4-E-009 Radiated Emission Test Result

**Test Site** : DDT 3m Chamber 1# D:\2017 RE1# Report Data\Q17112903-1E\Q17112904-1E FCC 1G-18G 5G WIFI .EM6  
**Test Date** : 2018-01-04 **Tested By** : Sunny  
**EUT** : Wireless speaker **Model Number** : ALLURE PORTABLE  
**Power Supply** : AC 120V/60Hz **Test Mode** : TX mode  
**Condition** : Temp:24.5'C,Humi:55%,  
 Press:100.1kPa **Antenna/Distance** : 2016 HF907/3m/HORIZONTAL  
**Memo** : 11n20 5745MHz

Data: 205

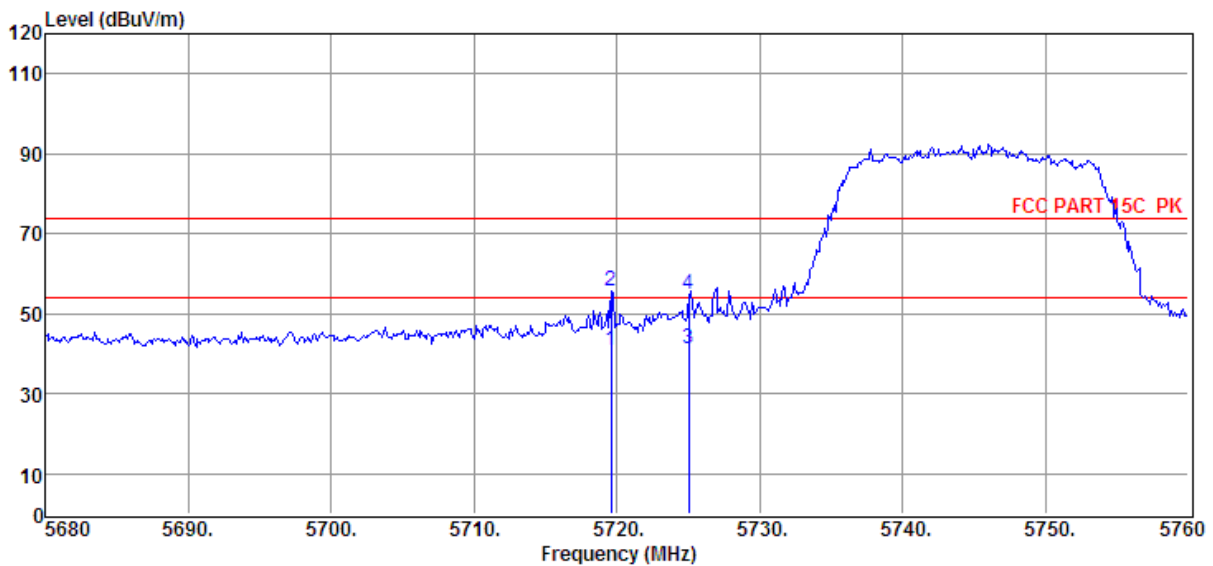

Item (Mark)	Freq. (MHz)	Read Level (dBµV)	Antenna Factor (dB/m)	PRM Factor (dB)	Cable Loss (dB)	Result Level (dBµV/m)	Limit Line (dBµV/m)	Over Limit (dB)	Detector	Polarization
1	5719.60	26.36	35.69	29.22	8.03	40.86	54.00	-13.14	Average	HORIZONTAL
2	5719.60	41.37	35.69	29.22	8.03	55.87	74.00	-18.13	Peak	HORIZONTAL
3	5725.00	26.67	35.69	29.22	8.04	41.18	54.00	-12.82	Average	HORIZONTAL
4	5725.00	40.31	35.69	29.22	8.04	54.82	74.00	-19.18	Peak	HORIZONTAL

Note: 1. Result Level = Read Level + Antenna Factor + Cable loss - PRM Factor.  
 2. If Peak Result complies with AV limit, AV Result is deemed to comply with AV limit.  
 3. Test setup: RBW: 1 MHz, VBW: 3 MHz, Sweep time: auto.

# TR-4-E-009 Radiated Emission Test Result

<b>Test Site</b>	: DDT 3m Chamber 1#	D:\2017 RE1# Report Data\Q17112903-1E\Q17112904-1E FCC 1G-18G 5G WIFI .EM6
<b>Test Date</b>	: 2018-01-04	<b>Tested By</b> : Sunny
<b>EUT</b>	: Wireless speaker	<b>Model Number</b> : ALLURE PORTABLE
<b>Power Supply</b>	: AC 120V/60Hz	<b>Test Mode</b> : TX mode
<b>Condition</b>	: Temp:24.5'C,Humi:55%, Press:100.1kPa	<b>Antenna/Distance</b> : 2016 HF907/3m/VERTICAL
<b>Memo</b>	: 11n20 5745MHz	

Data: 206

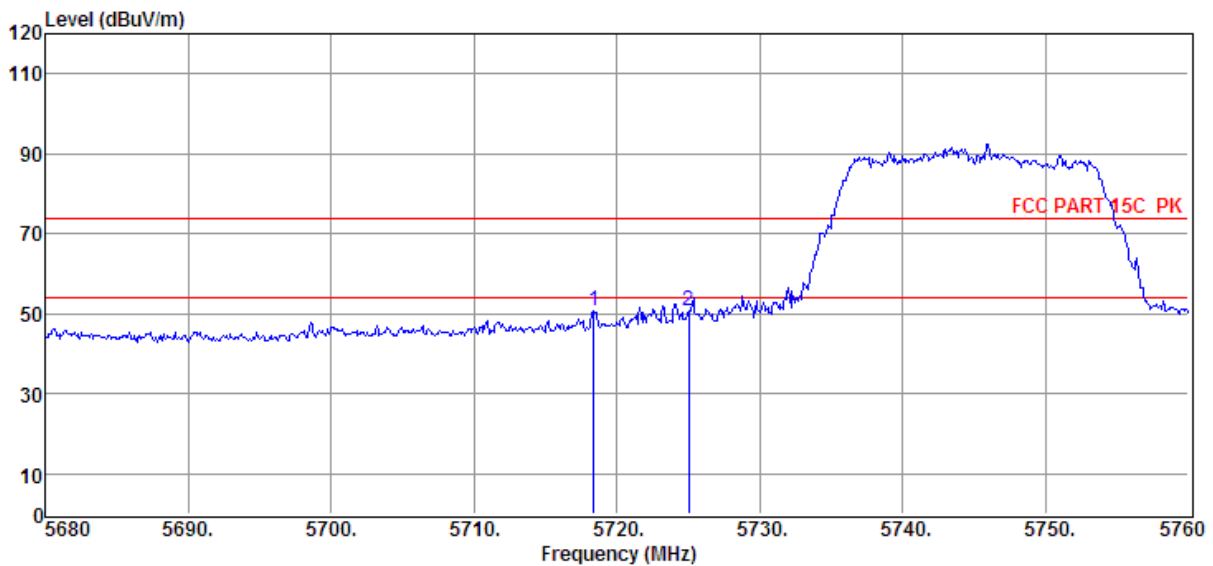

Item	Freq.	Read Level	Antenna Factor	PRM Factor	Cable Loss	Result Level	Limit Line	Over Limit	Detector	Polarization
(Mark)	(MHz)	(dBμV)	(dB/m)	dB	dB	(dBμV/m)	(dBμV/m)	(dB)		
1	5718.40	36.26	35.69	29.22	8.03	50.76	74.00	-23.24	Peak	VERTICAL
2	5725.00	36.29	35.69	29.22	8.04	50.80	74.00	-23.20	Peak	VERTICAL

- Note: 1. Result Level = Read Level + Antenna Factor + Cable loss - PRM Factor.  
 2. If Peak Result complies with AV limit, AV Result is deemed to comply with AV limit.  
 3. Test setup: RBW: 1 MHz, VBW: 3 MHz, Sweep time: auto.

# TR-4-E-009 Radiated Emission Test Result

<b>Test Site</b>	: DDT 3m Chamber 1#	D:\2017 RE1# Report Data\Q17112903-1E\Q17112904-1E
		FCC 1G-18G 5G WIFI .EM6
<b>Test Date</b>	: 2018-01-04	<b>Tested By</b> : Sunny
<b>EUT</b>	: Wireless speaker	<b>Model Number</b> : ALLURE PORTABLE
<b>Power Supply</b>	: AC 120V/60Hz	<b>Test Mode</b> : TX mode
<b>Condition</b>	: Temp:24.5'C,Humi:55%, Press:100.1kPa	<b>Antenna/Distance</b> : 2016 HF907/3m/HORIZONTAL
<b>Memo</b>	: 11n20 5825MHz	

Data: 207

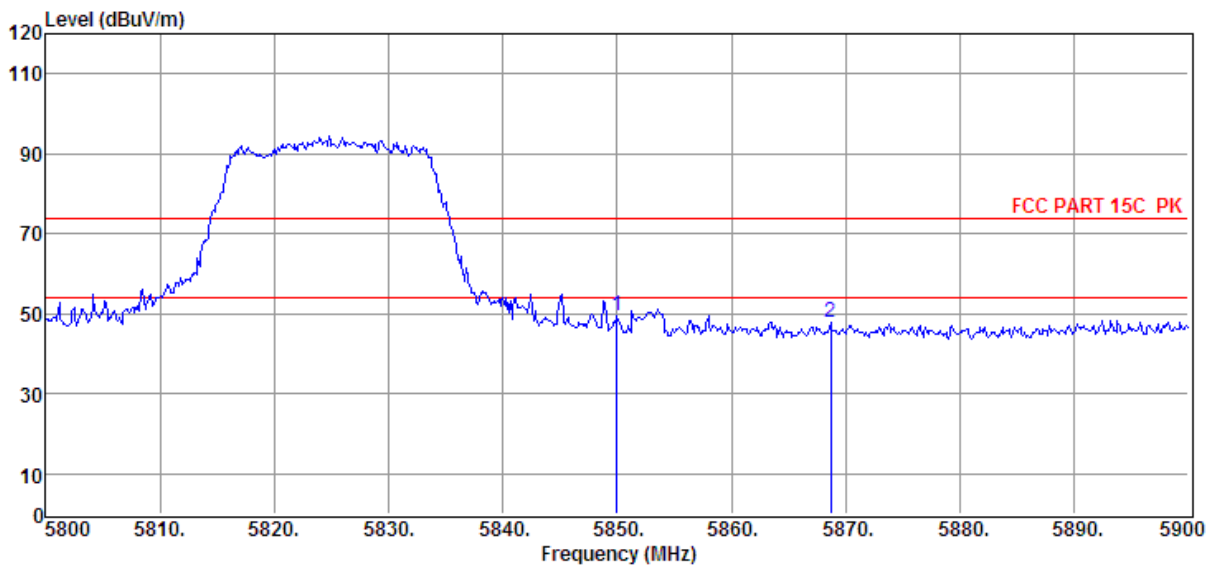

Item	Freq.	Read Level	Antenna Factor	PRM Factor	Cable Loss	Result Level	Limit Line	Over Limit	Detector	Polarization
(Mark)	(MHz)	(dBμV)	(dB/m)	dB	dB	(dBμV/m)	(dBμV/m)	(dB)		
1	5850.00	35.02	35.74	29.20	8.12	49.68	74.00	-24.3 2	Peak	HORIZONTAL
2	5868.70	33.19	35.75	29.20	8.13	47.87	74.00	-26.1 3	Peak	HORIZONTAL

Note: 1. Result Level = Read Level + Antenna Factor + Cable loss - PRM Factor.  
 2. If Peak Result complies with AV limit, AV Result is deemed to comply with AV limit.  
 3. Test setup: RBW: 1 MHz, VBW: 3 MHz, Sweep time: auto.

# TR-4-E-009 Radiated Emission Test Result

<b>Test Site</b>	: DDT 3m Chamber 1#	D:\2017 RE1# Report Data\Q17112903-1E\Q17112904-1E FCC 1G-18G 5G WIFI .EM6
<b>Test Date</b>	: 2018-01-04	<b>Tested By</b> : Sunny
<b>EUT</b>	: Wireless speaker	<b>Model Number</b> : ALLURE PORTABLE
<b>Power Supply</b>	: AC 120V/60Hz	<b>Test Mode</b> : TX mode
<b>Condition</b>	: Temp:24.5'C,Humi:55%, Press:100.1kPa	<b>Antenna/Distance</b> : 2016 HF907/3m/VERTICAL
<b>Memo</b>	: 11n20 5825MHz	

Data: 208

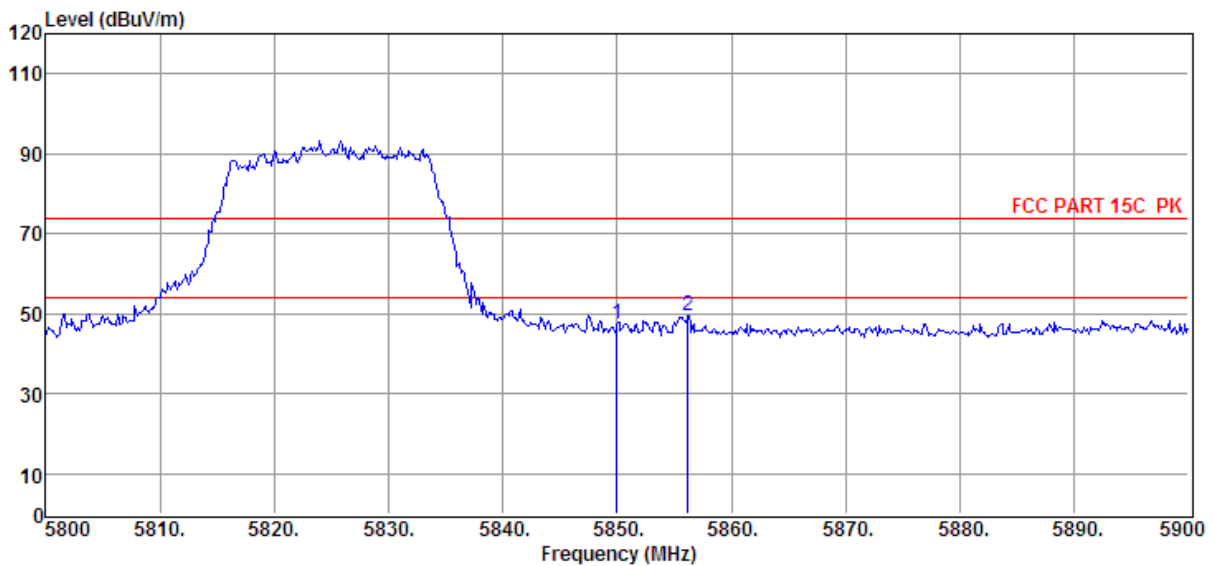

Item (Mark)	Freq. (MHz)	Read Level (dBµV)	Antenna Factor (dB/m)	PRM Facto r dB	Cable Loss dB	Result Level (dBµV/m)	Limit Line (dBµV/m)	Over Limit (dB)	Detector	Polarization
1	5850.00	32.92	35.74	29.20	8.12	47.58	74.00	-26.4 2	Peak	VERTICAL
2	5856.20	34.90	35.74	29.20	8.12	49.56	74.00	-24.4 4	Peak	VERTICAL

- Note: 1. Result Level = Read Level + Antenna Factor + Cable loss - PRM Factor.  
 2. If Peak Result complies with AV limit, AV Result is deemed to comply with AV limit.  
 3. Test setup: RBW: 1 MHz, VBW: 3 MHz, Sweep time: auto.

# TR-4-E-009 Radiated Emission Test Result

<b>Test Site</b>	: DDT 3m Chamber 1#	D:\2017 RE1# Report Data\Q17112903-1E\Q17112904-1E FCC 1G-18G 5G WIFI .EM6
<b>Test Date</b>	: 2018-01-04	<b>Tested By</b> : Sunny
<b>EUT</b>	: Wireless speaker	<b>Model Number</b> : ALLURE PORTABLE
<b>Power Supply</b>	: AC 120V/60Hz	<b>Test Mode</b> : TX mode
<b>Condition</b>	: Temp:24.5'C,Humi:55%, Press:100.1kPa	<b>Antenna/Distance</b> : 2016 HF907/3m/VERTICAL
<b>Memo</b>	: 11n40 5190MHz	

Data: 209

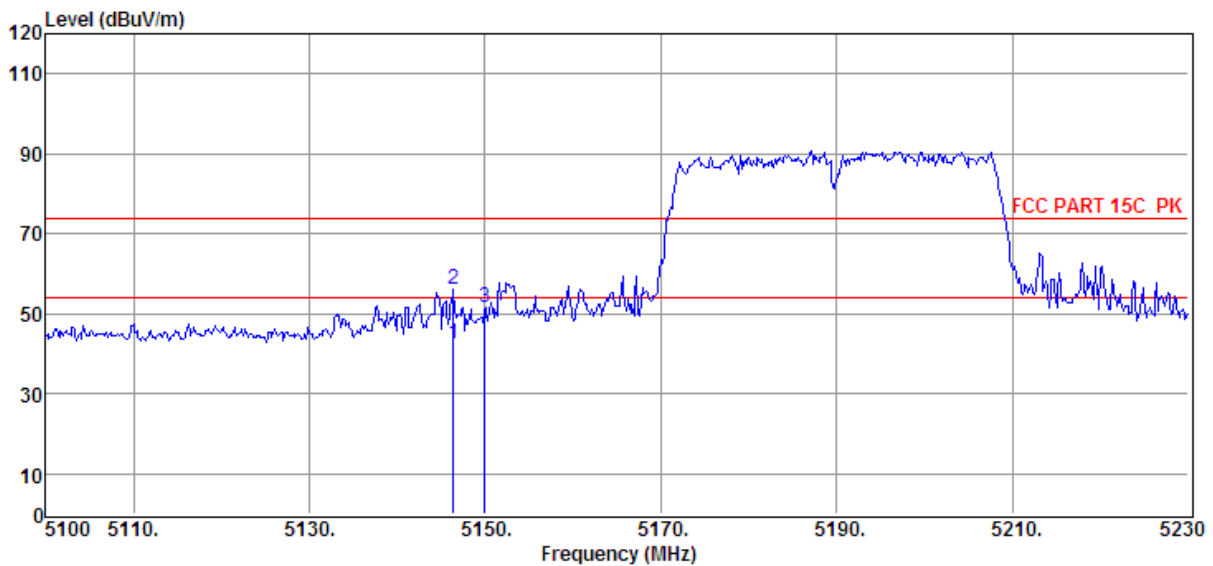

Item (Mark)	Freq. (MHz)	Read Level (dBμV)	Antenna Factor (dB/m)	PRM Facto r dB	Cable Loss dB	Result Level (dBμV/m)	Limit Line (dBμV/m)	Over Limit (dB)	Detector	Polarization
1	5146.41	29.15	35.18	29.33	7.67	42.67	54.00	-11.3 3	Average	VERTICAL
2	5146.41	42.65	35.18	29.33	7.67	56.17	74.00	-17.8 3	Peak	VERTICAL
3	5150.00	38.18	35.18	29.33	7.67	51.70	74.00	-22.3 0	Peak	VERTICAL

Note: 1. Result Level = Read Level + Antenna Factor + Cable loss - PRM Factor.  
 2. If Peak Result complies with AV limit, AV Result is deemed to comply with AV limit.  
 3. Test setup: RBW: 1 MHz, VBW: 3 MHz, Sweep time: auto.

# TR-4-E-009 Radiated Emission Test Result

<b>Test Site</b>	: DDT 3m Chamber 1#	D:\2017 RE1# Report Data\Q17112903-1E\Q17112904-1E FCC 1G-18G 5G WIFI .EM6
<b>Test Date</b>	: 2018-01-05	<b>Tested By</b> : Sunny
<b>EUT</b>	: Wireless speaker	<b>Model Number</b> : ALLURE PORTABLE
<b>Power Supply</b>	: AC 120V/60Hz	<b>Test Mode</b> : TX mode
<b>Condition</b>	: Temp:24.5'C,Humi:55%, Press:100.1kPa	<b>Antenna/Distance</b> : 2016 HF907/3m/HORIZONTAL
<b>Memo</b>	: 11n40 5190MHz	

Data: 210

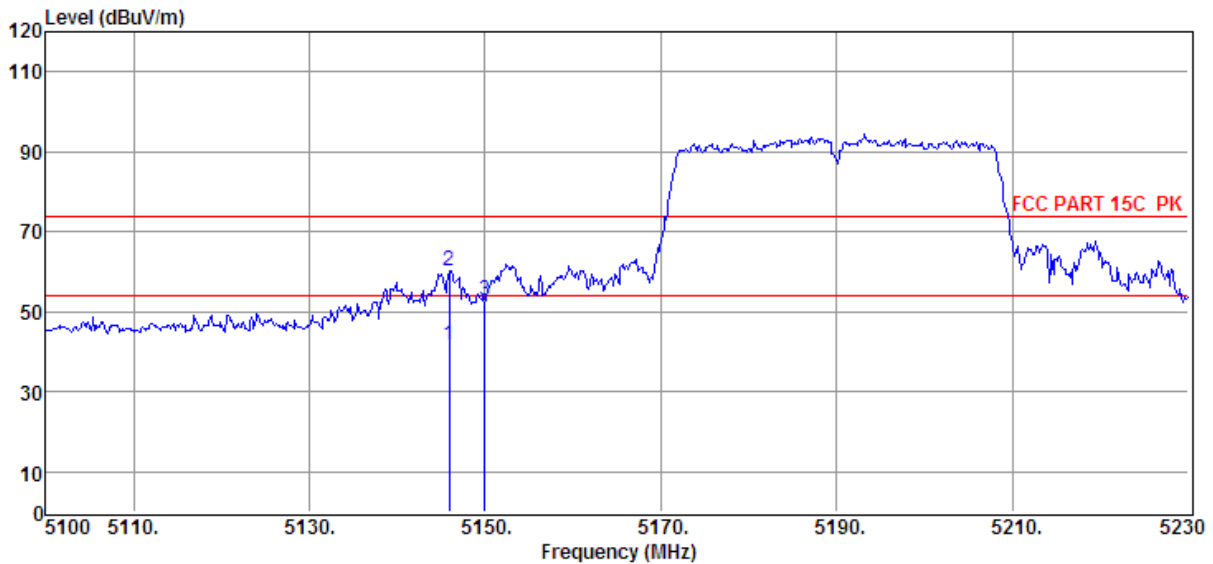

Item (Mark)	Freq. (MHz)	Read Level (dBµV)	Antenna Factor (dB/m)	PRM Facto r dB	Cable Loss dB	Result Level (dBµV/m)	Limit Line (dBµV/m)	Over Limit (dB)	Detector	Polarization
1	5145.89	28.17	35.18	29.33	7.67	41.69	54.00	-12.3 1	Average	HORIZONTAL
2	5145.89	46.78	35.18	29.33	7.67	60.30	74.00	-13.7 0	Peak	HORIZONTAL
3	5150.00	39.08	35.18	29.33	7.67	52.60	74.00	-21.4 0	Peak	HORIZONTAL

Note: 1. Result Level = Read Level + Antenna Factor + Cable loss - PRM Factor.  
 2. If Peak Result complies with AV limit, AV Result is deemed to comply with AV limit.  
 3. Test setup: RBW: 1 MHz, VBW: 3 MHz, Sweep time: auto.

# TR-4-E-009 Radiated Emission Test Result

<b>Test Site</b>	: DDT 3m Chamber 1#	D:\2017 RE1# Report Data\Q17112903-1E\Q17112904-1E FCC 1G-18G 5G WIFI .EM6
<b>Test Date</b>	: 2018-01-05	<b>Tested By</b> : Sunny
<b>EUT</b>	: Wireless speaker	<b>Model Number</b> : ALLURE PORTABLE
<b>Power Supply</b>	: AC 120V/60Hz	<b>Test Mode</b> : TX mode
<b>Condition</b>	: Temp:24.5'C,Humi:55%, Press:100.1kPa	<b>Antenna/Distance</b> : 2016 HF907/3m/VERTICAL
<b>Memo</b>	: 11n40 5230MHz	

Data: 211

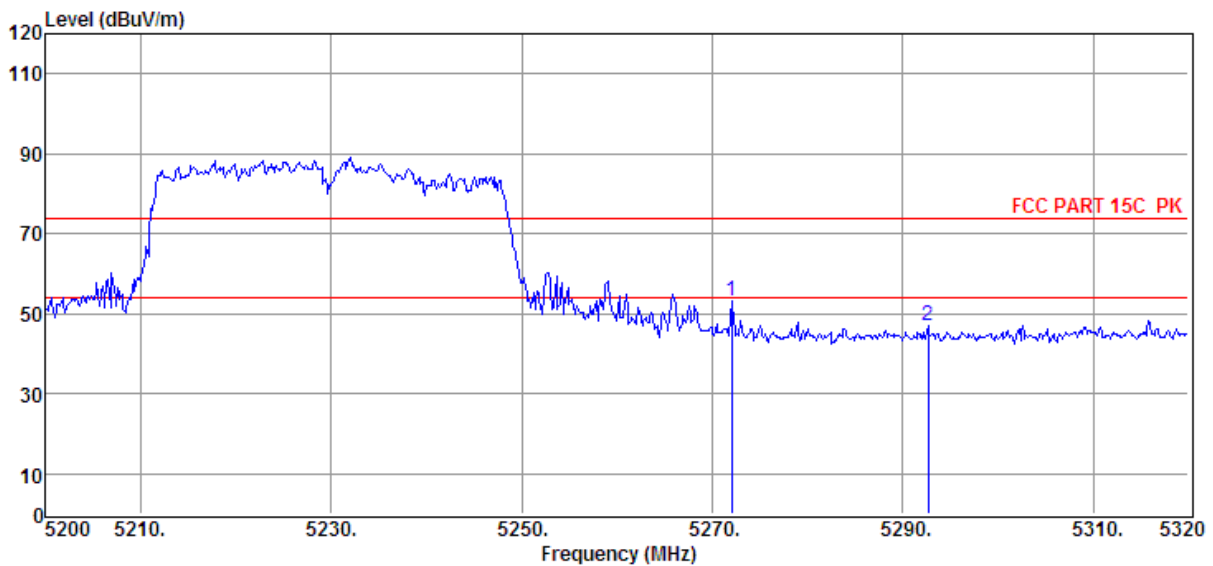

Item (Mark)	Freq. (MHz)	Read Level (dBµV)	Antenna Factor (dB/m)	PRM Facto r dB	Cable Loss dB	Result Level (dBµV/m)	Limit Line (dBµV/m)	Over Limit (dB)	Detector	Polarization
1	5272.00	39.36	35.33	29.32	7.75	53.12	74.00	-20.88	Peak	VERTICAL
2	5292.64	33.12	35.35	29.31	7.76	46.92	74.00	-27.08	Peak	VERTICAL

- Note: 1. Result Level = Read Level + Antenna Factor + Cable loss - PRM Factor.  
 2. If Peak Result complies with AV limit, AV Result is deemed to comply with AV limit.  
 3. Test setup: RBW: 1 MHz, VBW: 3 MHz, Sweep time: auto.

# TR-4-E-009 Radiated Emission Test Result

<b>Test Site</b>	: DDT 3m Chamber 1#	<b>D:\2017 RE1# Report Data\Q17112903-1E\Q17112904-1E</b>
		<b>FCC 1G-18G 5G WIFI .EM6</b>
<b>Test Date</b>	: 2018-01-05	<b>Tested By</b> : Sunny
<b>EUT</b>	: Wireless speaker	<b>Model Number</b> : ALLURE PORTABLE
<b>Power Supply</b>	: AC 120V/60Hz	<b>Test Mode</b> : TX mode
<b>Condition</b>	: Temp:24.5'C,Humi:55%, Press:100.1kPa	<b>Antenna/Distance</b> : 2016 HF907/3m/HORIZONTAL
<b>Memo</b>	: 11n40 5230MHz	

Data: 212

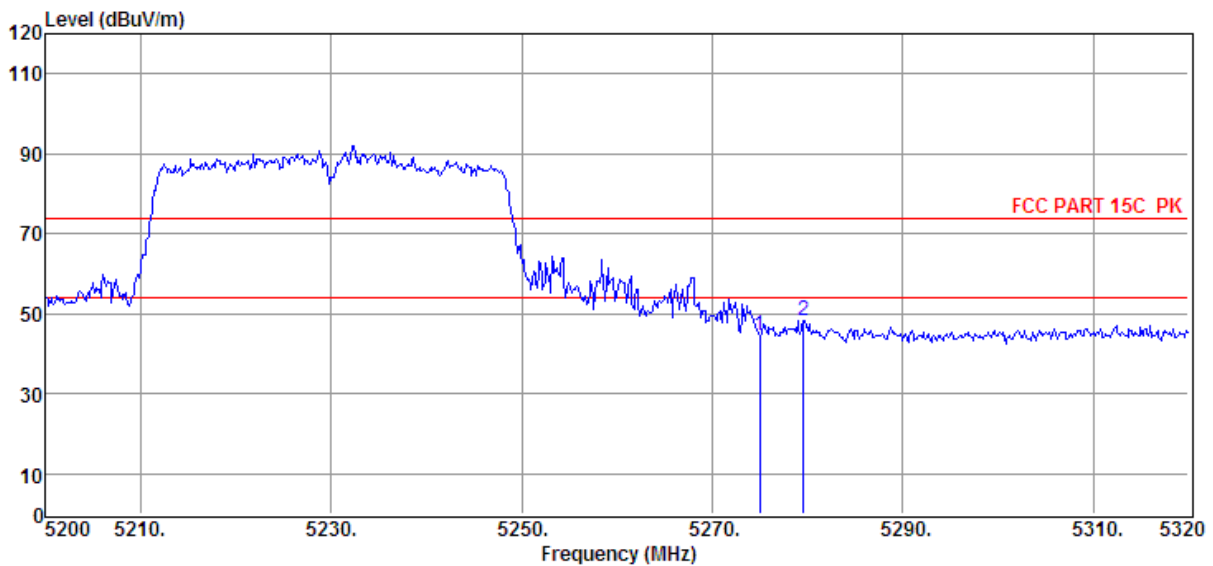

Item	Freq.	Read Level	Antenna Factor	PRM Factor	Cable Loss	Result Level	Limit Line	Over Limit	Detector	Polarization
(Mark)	(MHz)	(dBμV)	(dB/m)	dB	dB	(dBμV/m)	(dBμV/m)	(dB)		
1	5275.00	30.97	35.33	29.31	7.75	44.74	74.00	-29.26	Peak	HORIZONTAL
2	5279.56	34.66	35.34	29.31	7.76	48.45	74.00	-25.55	Peak	HORIZONTAL

- Note: 1. Result Level = Read Level + Antenna Factor + Cable loss - PRM Factor.  
 2. If Peak Result complies with AV limit, AV Result is deemed to comply with AV limit.  
 3. Test setup: RBW: 1 MHz, VBW: 3 MHz, Sweep time: auto.

# TR-4-E-009 Radiated Emission Test Result

<b>Test Site</b>	: DDT 3m Chamber 1#	D:\2017 RE1# Report Data\Q17112903-1E\Q17112904-1E FCC 1G-18G 5G WIFI .EM6
<b>Test Date</b>	: 2018-01-05	<b>Tested By</b> : Sunny
<b>EUT</b>	: Wireless speaker	<b>Model Number</b> : ALLURE PORTABLE
<b>Power Supply</b>	: AC 120V/60Hz	<b>Test Mode</b> : TX mode
<b>Condition</b>	: Temp:24.5'C,Humi:55%, Press:100.1kPa	<b>Antenna/Distance</b> : 2016 HF907/3m/HORIZONTAL
<b>Memo</b>	: 11n40 5270MHz	

Data: 213

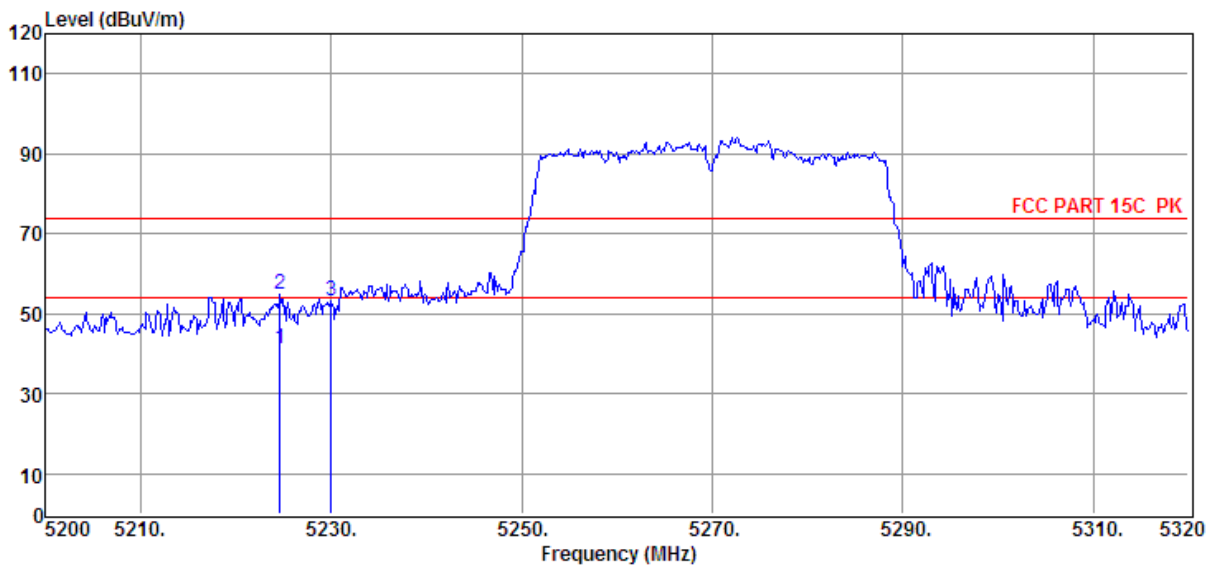

Item (Mark)	Freq. (MHz)	Read Level (dBµV)	Antenna Factor (dB/m)	PRM Facto r dB	Cable Loss dB	Result Level (dBµV/m)	Limit Line (dBµV/m)	Over Limit (dB)	Detector	Polarization
1	5224.60	27.65	35.27	29.32	7.72	41.32	54.00	-12.68	Average	HORIZONTAL
2	5224.60	41.06	35.27	29.32	7.72	54.73	74.00	-19.27	Peak	HORIZONTAL
3	5230.00	39.64	35.28	29.32	7.72	53.32	74.00	-20.68	Peak	HORIZONTAL

Note: 1. Result Level = Read Level + Antenna Factor + Cable loss - PRM Factor.  
 2. If Peak Result complies with AV limit, AV Result is deemed to comply with AV limit.  
 3. Test setup: RBW: 1 MHz, VBW: 3 MHz, Sweep time: auto.

# TR-4-E-009 Radiated Emission Test Result

<b>Test Site</b>	: DDT 3m Chamber 1#	D:\2017 RE1# Report Data\Q17112903-1E\Q17112904-1E FCC 1G-18G 5G WIFI .EM6
<b>Test Date</b>	: 2018-01-05	<b>Tested By</b> : Sunny
<b>EUT</b>	: Wireless speaker	<b>Model Number</b> : ALLURE PORTABLE
<b>Power Supply</b>	: AC 120V/60Hz	<b>Test Mode</b> : TX mode
<b>Condition</b>	: Temp:24.5'C,Humi:55%, Press:100.1kPa	<b>Antenna/Distance</b> : 2016 HF907/3m/VERTICAL
<b>Memo</b>	: 11n40 5270MHz	

Data: 214

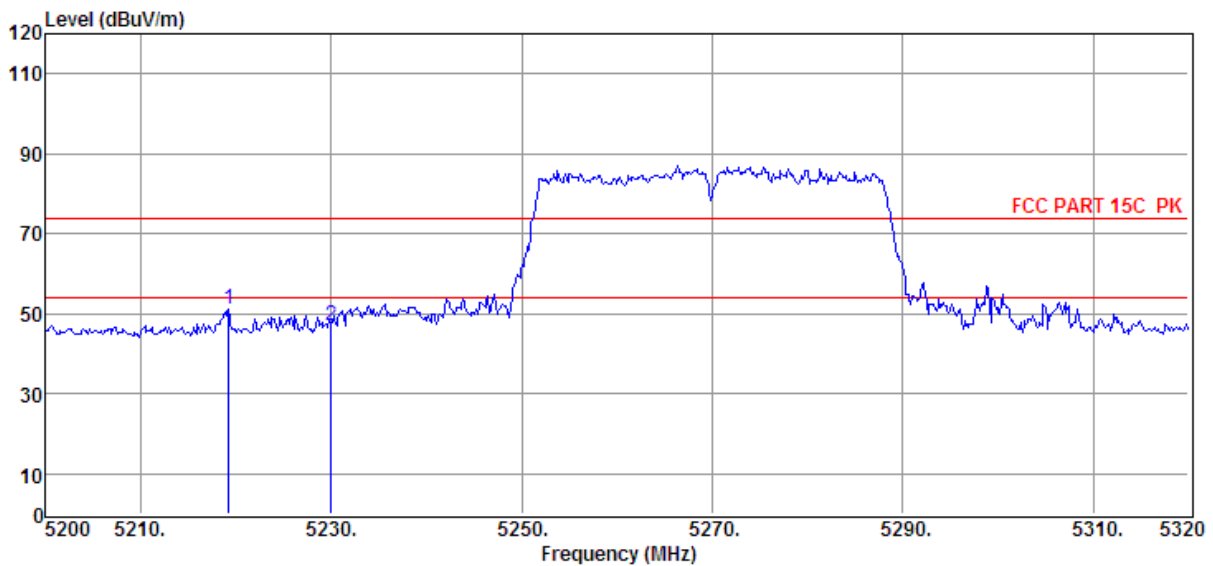

Item	Freq.	Read Level	Antenna Factor	PRM Factor	Cable Loss	Result Level	Limit Line	Over Limit	Detector	Polarization
(Mark)	(MHz)	(dBμV)	(dB/m)	dB	dB	(dBμV/m)	(dBμV/m)	(dB)		
1	5219.20	37.68	35.26	29.33	7.72	51.33	74.00	-22.67	Peak	VERTICAL
2	5230.00	33.26	35.28	29.32	7.72	46.94	74.00	-27.06	Peak	VERTICAL

- Note: 1. Result Level = Read Level + Antenna Factor + Cable loss - PRM Factor.  
 2. If Peak Result complies with AV limit, AV Result is deemed to comply with AV limit.  
 3. Test setup: RBW: 1 MHz, VBW: 3 MHz, Sweep time: auto.

# TR-4-E-009 Radiated Emission Test Result

<b>Test Site</b>	: DDT 3m Chamber 1#	<b>D:\2017 RE1# Report Data\Q17112903-1E\Q17112904-1E</b>
		<b>FCC 1G-18G 5G WIFI .EM6</b>
<b>Test Date</b>	: 2018-01-05	<b>Tested By</b> : Sunny
<b>EUT</b>	: Wireless speaker	<b>Model Number</b> : ALLURE PORTABLE
<b>Power Supply</b>	: AC 120V/60Hz	<b>Test Mode</b> : TX mode
<b>Condition</b>	: Temp:24.5'C,Humi:55%, Press:100.1kPa	<b>Antenna/Distance</b> : 2016 HF907/3m/VERTICAL
<b>Memo</b>	: 11n40 5310MHz	

Data: 215

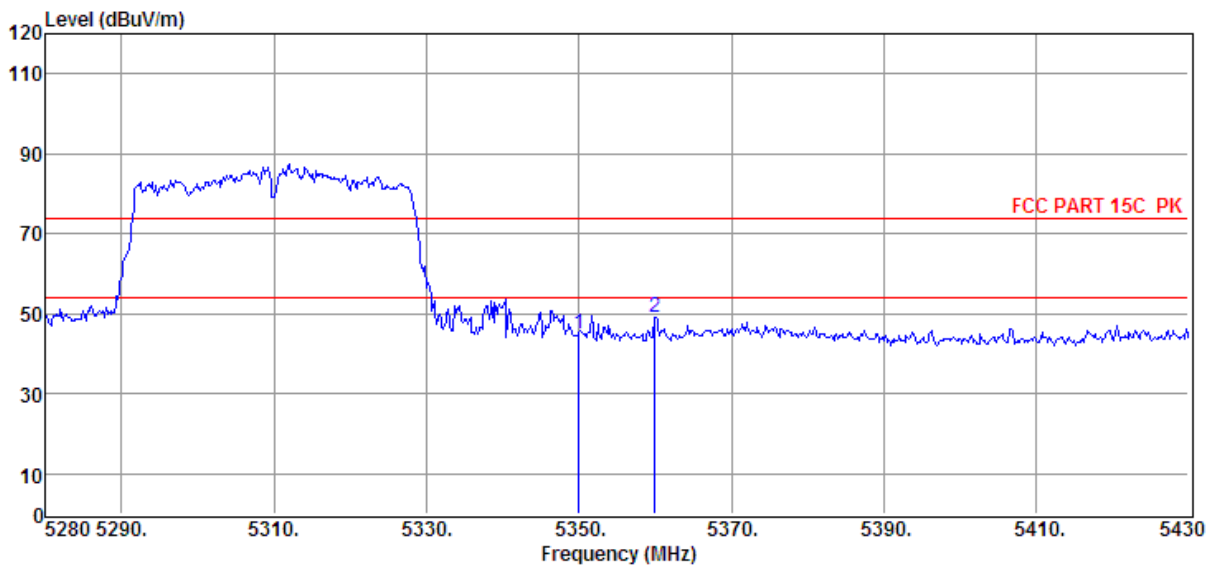

Item	Freq.	Read Level	Antenna Factor	PRM Factor	Cable Loss	Result Level	Limit Line	Over Limit	Detector	Polarization
(Mark)	(MHz)	(dBμV)	(dB/m)	dB	dB	(dBμV/m)	(dBμV/m)	(dB)		
1	5350.05	31.22	35.42	29.30	7.80	45.14	74.00	-28.86	Peak	VERTICAL
2	5359.95	35.29	35.43	29.30	7.81	49.23	74.00	-24.77	Peak	VERTICAL

Note: 1. Result Level = Read Level + Antenna Factor + Cable loss - PRM Factor.  
 2. If Peak Result complies with AV limit, AV Result is deemed to comply with AV limit.  
 3. Test setup: RBW: 1 MHz, VBW: 3 MHz, Sweep time: auto.

# TR-4-E-009 Radiated Emission Test Result

<b>Test Site</b>	: DDT 3m Chamber 1#	D:\2017 RE1# Report Data\Q17112903-1E\Q17112904-1E
		FCC 1G-18G 5G WIFI .EM6
<b>Test Date</b>	: 2018-01-05	<b>Tested By</b> : Sunny
<b>EUT</b>	: Wireless speaker	<b>Model Number</b> : ALLURE PORTABLE
<b>Power Supply</b>	: AC 120V/60Hz	<b>Test Mode</b> : TX mode
<b>Condition</b>	: Temp:24.5'C,Humi:55%, Press:100.1kPa	<b>Antenna/Distance</b> : 2016 HF907/3m/HORIZONTAL
<b>Memo</b>	: 11n40 5310MHz	

Data: 216

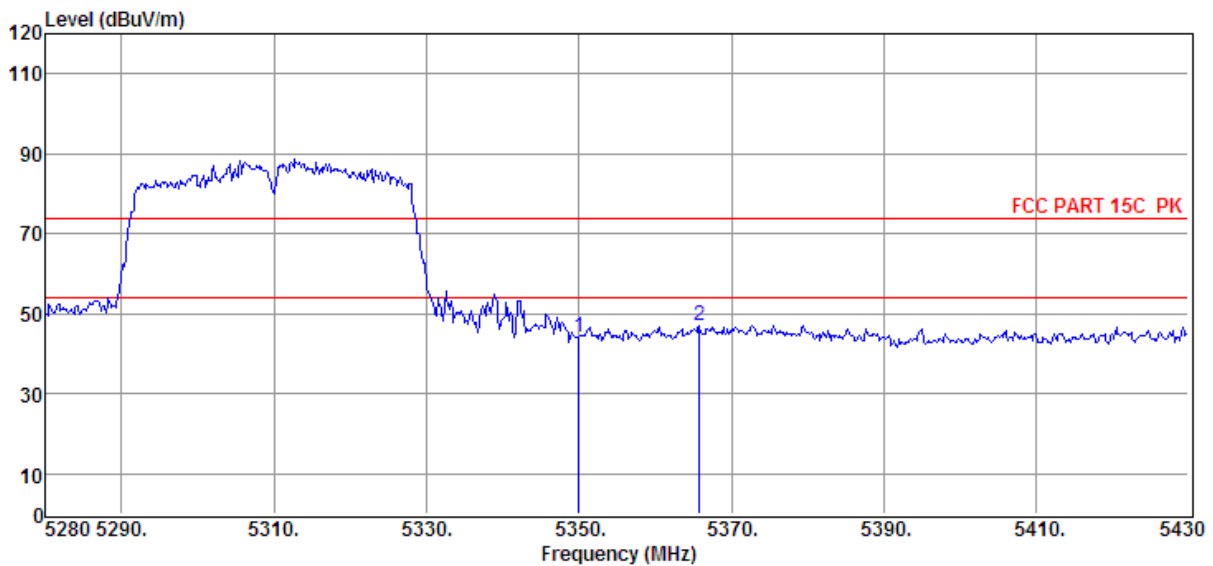

Item	Freq.	Read Level	Antenna Factor	PRM Factor	Cable Loss	Result Level	Limit Line	Over Limit	Detector	Polarization
(Mark)	(MHz)	(dBμV)	(dB/m)	dB	dB	(dBμV/m)	(dBμV/m)	(dB)		
1	5350.05	30.34	35.42	29.30	7.80	44.26	74.00	-29.74	Peak	HORIZONTAL
2	5365.80	32.95	35.44	29.30	7.81	46.90	74.00	-27.10	Peak	HORIZONTAL

- Note: 1. Result Level = Read Level + Antenna Factor + Cable loss - PRM Factor.  
 2. If Peak Result complies with AV limit, AV Result is deemed to comply with AV limit.  
 3. Test setup: RBW: 1 MHz, VBW: 3 MHz, Sweep time: auto.

# TR-4-E-009 Radiated Emission Test Result

<b>Test Site</b>	: DDT 3m Chamber 1#	D:\2017 RE1# Report Data\Q17112903-1E\Q17112904-1E
		FCC 1G-18G 5G WIFI .EM6
<b>Test Date</b>	: 2018-01-05	<b>Tested By</b> : Sunny
<b>EUT</b>	: Wireless speaker	<b>Model Number</b> : ALLURE PORTABLE
<b>Power Supply</b>	: AC 120V/60Hz	<b>Test Mode</b> : TX mode
<b>Condition</b>	: Temp:24.5'C,Humi:55%, Press:100.1kPa	<b>Antenna/Distance</b> : 2016 HF907/3m/HORIZONTAL
<b>Memo</b>	: 11n40 5510MHz	

Data: 217

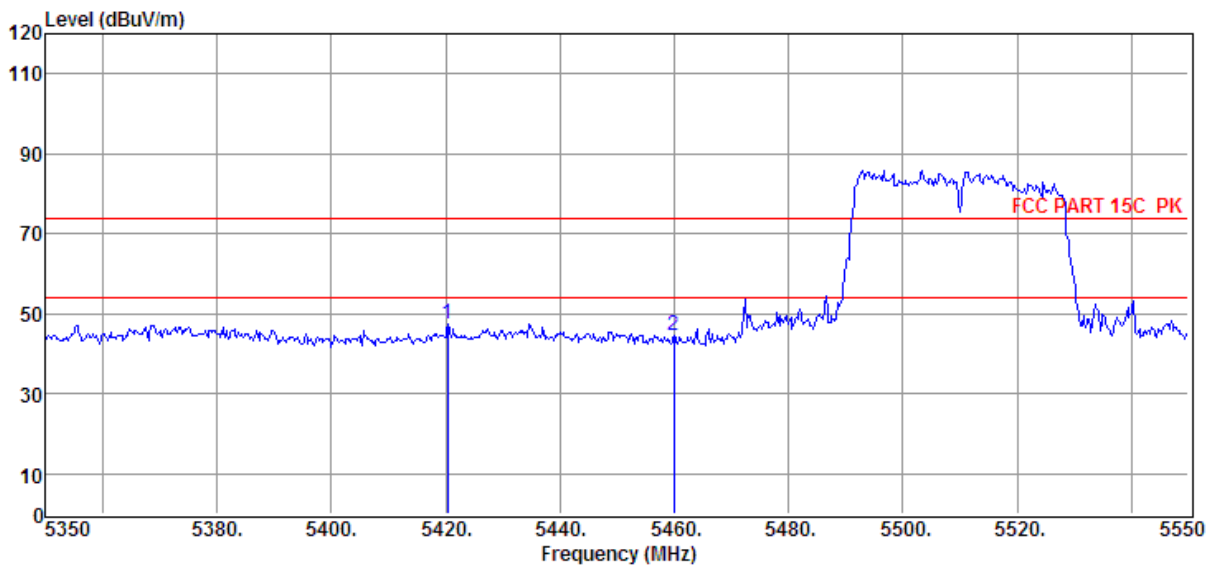

Item	Freq.	Read Level	Antenna Factor	PRM Factor	Cable Loss	Result Level	Limit Line	Over Limit	Detector	Polarization
(Mark)	(MHz)	(dBμV)	(dB/m)	dB	dB	(dBμV/m)	(dBμV/m)	(dB)		
1	5420.40	33.22	35.50	29.28	7.84	47.28	74.00	-26.72	Peak	HORIZONTAL
2	5460.00	30.58	35.55	29.28	7.87	44.72	74.00	-29.28	Peak	HORIZONTAL

Note: 1. Result Level = Read Level + Antenna Factor + Cable loss - PRM Factor.  
 2. If Peak Result complies with AV limit, AV Result is deemed to comply with AV limit.  
 3. Test setup: RBW: 1 MHz, VBW: 3 MHz, Sweep time: auto.

# TR-4-E-009 Radiated Emission Test Result

<b>Test Site</b>	: DDT 3m Chamber 1#	D:\2017 RE1# Report Data\Q17112903-1E\Q17112904-1E FCC 1G-18G 5G WIFI .EM6
<b>Test Date</b>	: 2018-01-05	<b>Tested By</b> : Sunny
<b>EUT</b>	: Wireless speaker	<b>Model Number</b> : ALLURE PORTABLE
<b>Power Supply</b>	: AC 120V/60Hz	<b>Test Mode</b> : TX mode
<b>Condition</b>	: Temp:24.5'C,Humi:55%, Press:100.1kPa	<b>Antenna/Distance</b> : 2016 HF907/3m/VERTICAL
<b>Memo</b>	: 11n40 5510MHz	

Data: 218

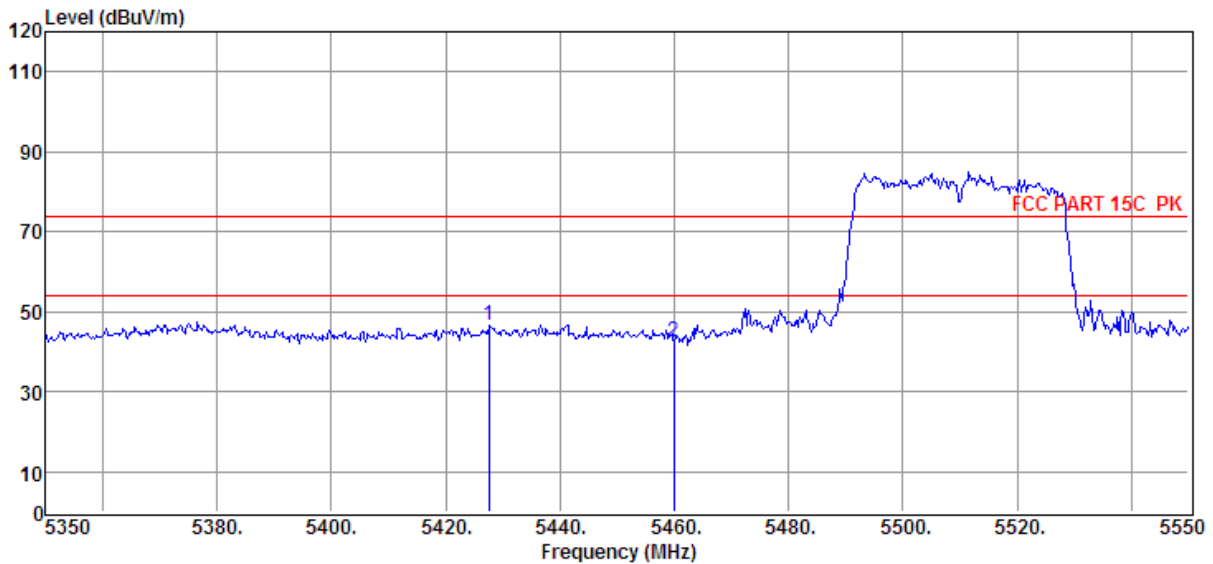

Item	Freq.	Read Level	Antenna Factor	PRM Factor	Cable Loss	Result Level	Limit Line	Over Limit	Detector	Polarization
(Mark)	(MHz)	(dBμV)	(dB/m)	dB	dB	(dBμV/m)	(dBμV/m)	(dB)		
1	5427.60	32.37	35.51	29.28	7.85	46.45	74.00	-27.55	Peak	VERTICAL
2	5460.00	28.20	35.55	29.28	7.87	42.34	74.00	-31.66	Peak	VERTICAL

Note: 1. Result Level = Read Level + Antenna Factor + Cable loss - PRM Factor.  
 2. If Peak Result complies with AV limit, AV Result is deemed to comply with AV limit.  
 3. Test setup: RBW: 1 MHz, VBW: 3 MHz, Sweep time: auto.

# TR-4-E-009 Radiated Emission Test Result

<b>Test Site</b>	: DDT 3m Chamber 1#	D:\2017 RE1# Report Data\Q17112903-1E\Q17112904-1E
		FCC 1G-18G 5G WIFI .EM6
<b>Test Date</b>	: 2018-01-05	<b>Tested By</b> : Sunny
<b>EUT</b>	: Wireless speaker	<b>Model Number</b> : ALLURE PORTABLE
<b>Power Supply</b>	: AC 120V/60Hz	<b>Test Mode</b> : TX mode
<b>Condition</b>	: Temp:24.5'C,Humi:55%, Press:100.1kPa	<b>Antenna/Distance</b> : 2016 HF907/3m/VERTICAL
<b>Memo</b>	: 11n40 5670MHz	

Data: 219

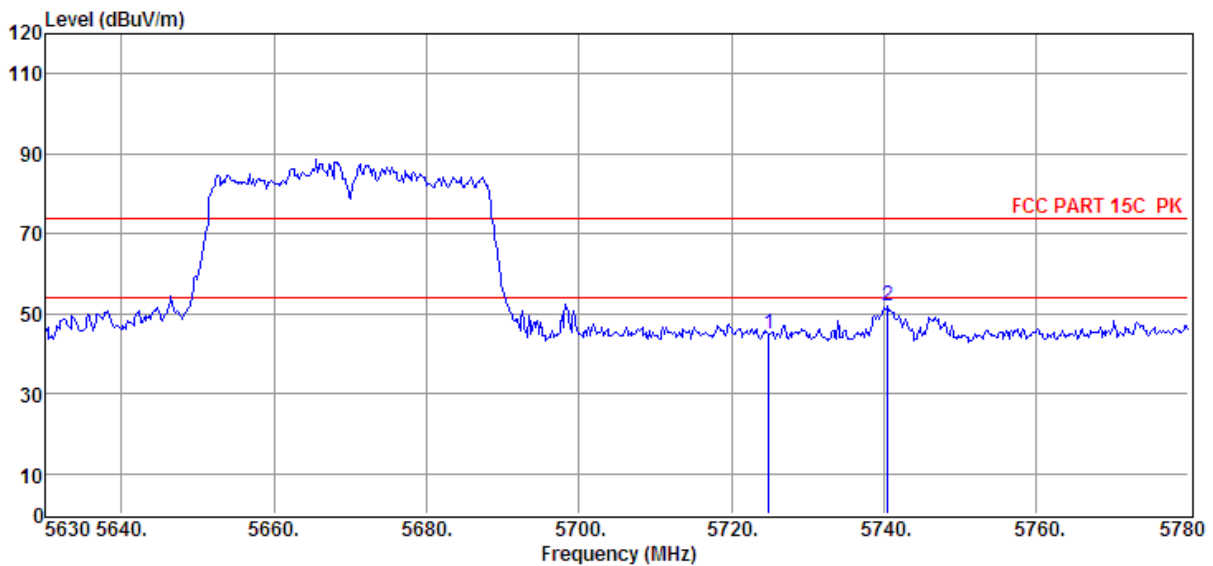

Item	Freq.	Read Level	Antenna Factor	PRM Factor	Cable Loss	Result Level	Limit Line	Over Limit	Detector	Polarization
(Mark)	(MHz)	(dBμV)	(dB/m)	dB	dB	(dBμV/m)	(dBμV/m)	(dB)		
1	5724.95	30.52	35.69	29.22	8.04	45.03	74.00	-28.97	Peak	VERTICAL
2	5740.55	37.59	35.70	29.21	8.05	52.13	74.00	-21.87	Peak	VERTICAL

- Note: 1. Result Level = Read Level + Antenna Factor + Cable loss - PRM Factor.  
 2. If Peak Result complies with AV limit, AV Result is deemed to comply with AV limit.  
 3. Test setup: RBW: 1 MHz, VBW: 3 MHz, Sweep time: auto.

# TR-4-E-009 Radiated Emission Test Result

<b>Test Site</b>	: DDT 3m Chamber 1#	D:\2017 RE1# Report Data\Q17112903-1E\Q17112904-1E
		FCC 1G-18G 5G WIFI .EM6
<b>Test Date</b>	: 2018-01-05	<b>Tested By</b> : Sunny
<b>EUT</b>	: Wireless speaker	<b>Model Number</b> : ALLURE PORTABLE
<b>Power Supply</b>	: AC 120V/60Hz	<b>Test Mode</b> : TX mode
<b>Condition</b>	: Temp:24.5'C,Humi:55%, Press:100.1kPa	<b>Antenna/Distance</b> : 2016 HF907/3m/HORIZONTAL
<b>Memo</b>	: 11n40 5670MHz	

Data: 220

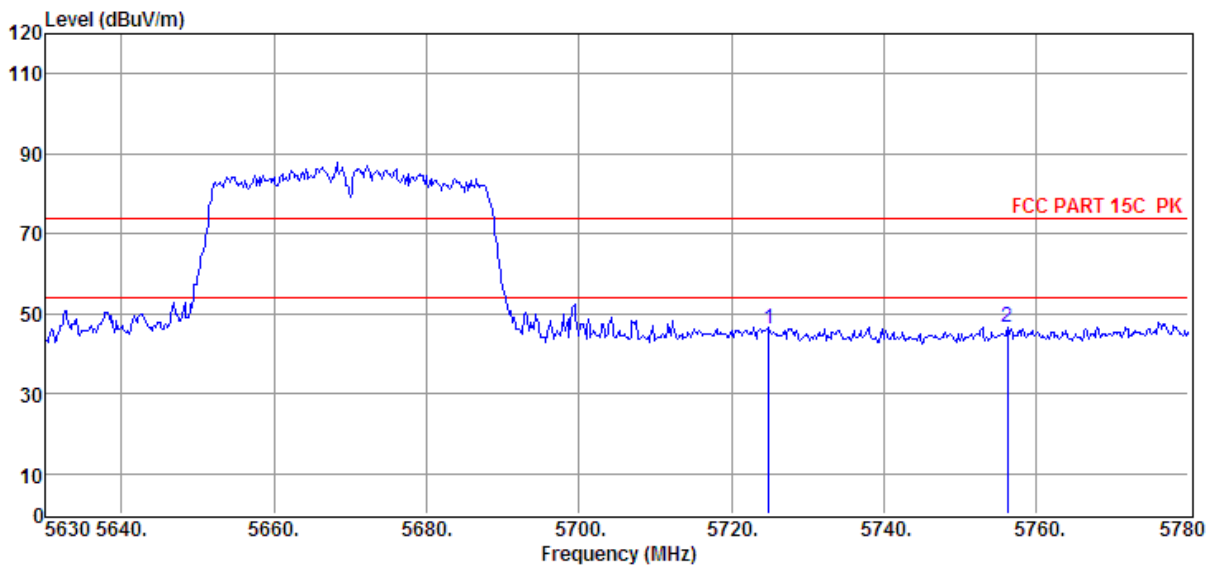

Item	Freq.	Read Level	Antenna Factor	PRM Factor	Cable Loss	Result Level	Limit Line	Over Limit	Detector	Polarization
(Mark)	(MHz)	(dBμV)	(dB/m)	dB	dB	(dBμV/m)	(dBμV/m)	(dB)		
1	5724.95	31.74	35.69	29.22	8.04	46.25	74.00	-27.75	Peak	HORIZONTAL
2	5756.30	32.16	35.70	29.21	8.06	46.71	74.00	-27.29	Peak	HORIZONTAL

- Note: 1. Result Level = Read Level + Antenna Factor + Cable loss - PRM Factor.  
 2. If Peak Result complies with AV limit, AV Result is deemed to comply with AV limit.  
 3. Test setup: RBW: 1 MHz, VBW: 3 MHz, Sweep time: auto.

# TR-4-E-009 Radiated Emission Test Result

<b>Test Site</b>	: DDT 3m Chamber 1#	<b>D:\2017 RE1# Report Data\Q17112903-1E\Q17112904-1E FCC 1G-18G 5G WIFI .EM6</b>
<b>Test Date</b>	: 2018-01-05	<b>Tested By</b> : Sunny
<b>EUT</b>	: Wireless speaker	<b>Model Number</b> : ALLURE PORTABLE
<b>Power Supply</b>	: AC 120V/60Hz	<b>Test Mode</b> : TX mode
<b>Condition</b>	: Temp:24.5'C,Humi:55%, Press:100.1kPa	<b>Antenna/Distance</b> : 2016 HF907/3m/VERTICAL
<b>Memo</b>	: 11n40 5755MHz	

Data: 221

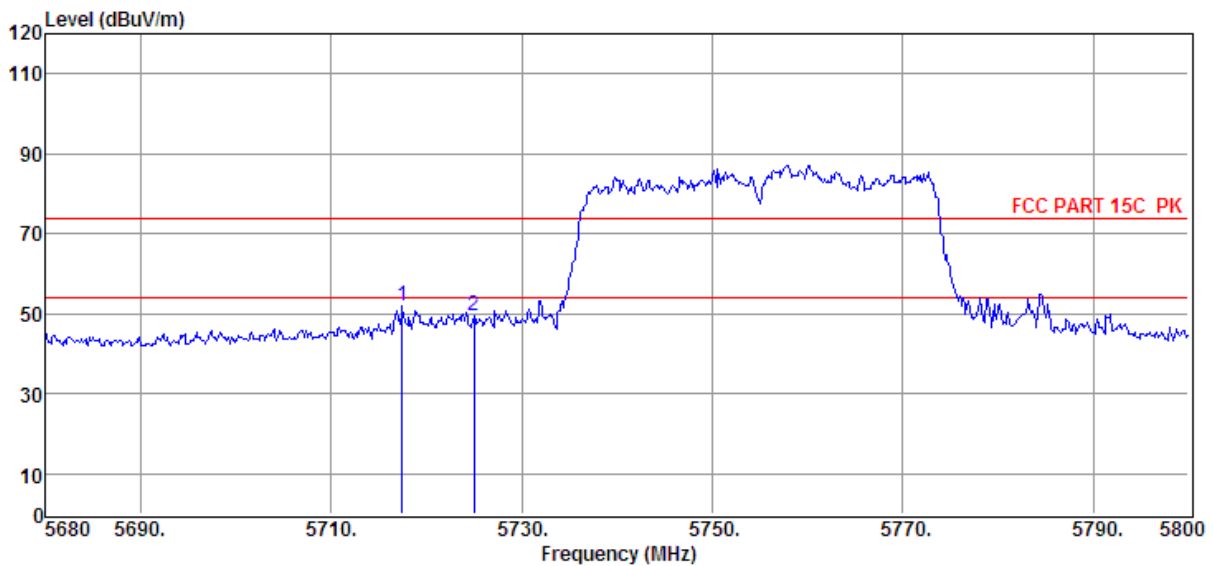

Item (Mark)	Freq. (MHz)	Read Level (dBμV)	Antenna Factor (dB/m)	PRM Factor (dB)	Cable Loss (dB)	Result Level (dBμV/m)	Limit Line (dBμV/m)	Over Limit (dB)	Detector	Polarization
1	5717.44	37.57	35.69	29.22	8.03	52.07	74.00	-21.93	Peak	VERTICAL
2	5725.00	35.08	35.69	29.22	8.04	49.59	74.00	-24.41	Peak	VERTICAL

Note: 1. Result Level = Read Level + Antenna Factor + Cable loss - PRM Factor.  
 2. If Peak Result complies with AV limit, AV Result is deemed to comply with AV limit.  
 3. Test setup: RBW: 1 MHz, VBW: 3 MHz, Sweep time: auto.

# TR-4-E-009 Radiated Emission Test Result

<b>Test Site</b>	: DDT 3m Chamber 1#	D:\2017 RE1# Report Data\Q17112903-1E\Q17112904-1E FCC 1G-18G 5G WIFI .EM6
<b>Test Date</b>	: 2018-01-05	<b>Tested By</b> : Sunny
<b>EUT</b>	: Wireless speaker	<b>Model Number</b> : ALLURE PORTABLE
<b>Power Supply</b>	: AC 120V/60Hz	<b>Test Mode</b> : TX mode
<b>Condition</b>	: Temp:24.5'C,Humi:55%, Press:100.1kPa	<b>Antenna/Distance</b> : 2016 HF907/3m/HORIZONTAL
<b>Memo</b>	: 11n40 5755MHz	

Data: 222

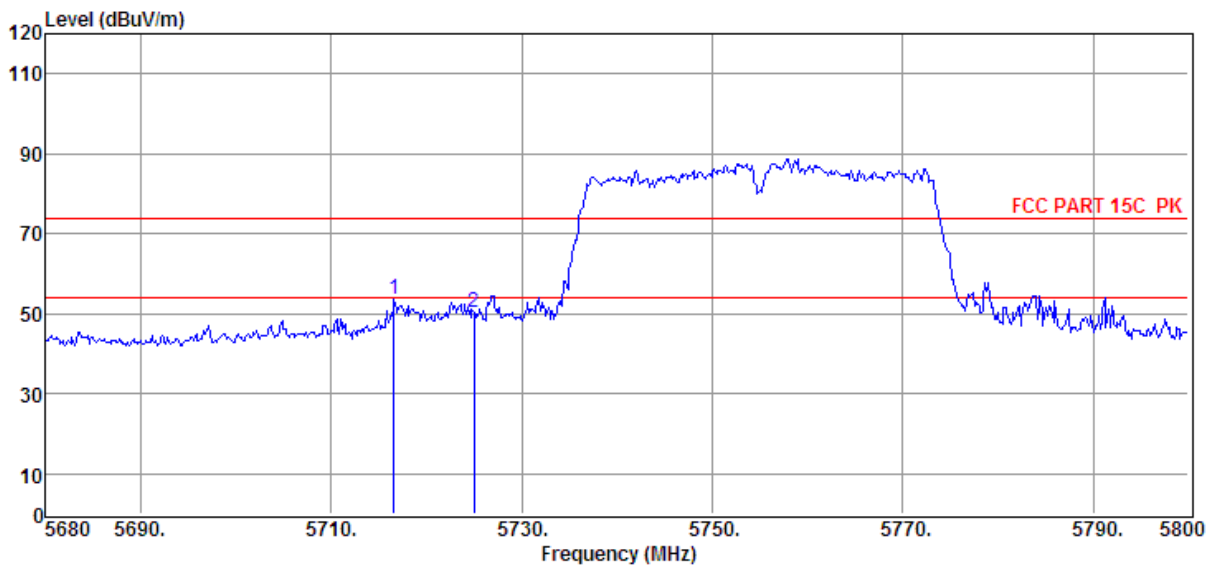

Item	Freq.	Read Level	Antenna Factor	PRM Factor	Cable Loss	Result Level	Limit Line	Over Limit	Detector	Polarization
(Mark)	(MHz)	(dBμV)	(dB/m)	dB	dB	(dBμV/m)	(dBμV/m)	(dB)		
1	5716.60	38.96	35.69	29.22	8.03	53.46	74.00	-20.54	Peak	HORIZONTAL
2	5725.00	35.99	35.69	29.22	8.04	50.50	74.00	-23.50	Peak	HORIZONTAL

Note: 1. Result Level = Read Level + Antenna Factor + Cable loss - PRM Factor.  
 2. If Peak Result complies with AV limit, AV Result is deemed to comply with AV limit.  
 3. Test setup: RBW: 1 MHz, VBW: 3 MHz, Sweep time: auto.

# TR-4-E-009 Radiated Emission Test Result

<b>Test Site</b>	: DDT 3m Chamber 1#	<b>D:\2017 RE1# Report Data\Q17112903-1E\Q17112904-1E FCC 1G-18G 5G WIFI .EM6</b>
<b>Test Date</b>	: 2018-01-05	<b>Tested By</b> : Sunny
<b>EUT</b>	: Wireless speaker	<b>Model Number</b> : ALLURE PORTABLE
<b>Power Supply</b>	: AC 120V/60Hz	<b>Test Mode</b> : TX mode
<b>Condition</b>	: Temp:24.5'C,Humi:55%, Press:100.1kPa	<b>Antenna/Distance</b> : 2016 HF907/3m/HORIZONTAL
<b>Memo</b>	: 11n40 5795MHz	

Data: 223

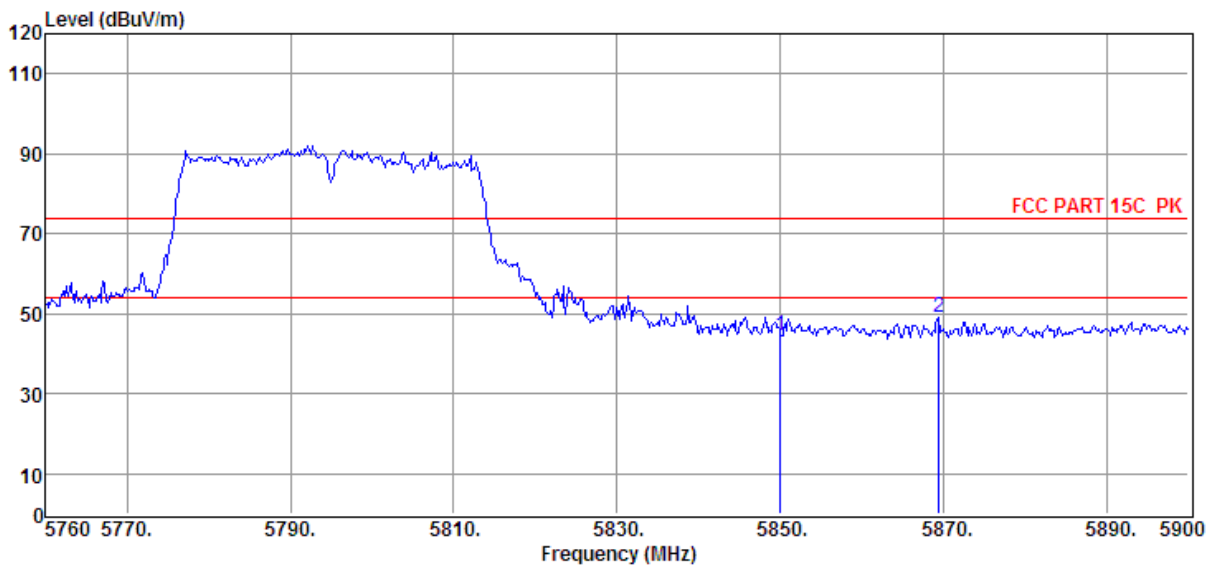

Item	Freq.	Read Level	Antenna Factor	PRM Factor	Cable Loss	Result Level	Limit Line	Over Limit	Detector	Polarization
(Mark)	(MHz)	(dBμV)	(dB/m)	dB	dB	(dBμV/m)	(dBμV/m)	(dB)		
1	5850.02	30.05	35.74	29.20	8.12	44.71	74.00	-29.29	Peak	HORIZONTAL
2	5869.48	34.27	35.75	29.20	8.13	48.95	74.00	-25.05	Peak	HORIZONTAL

- Note: 1. Result Level = Read Level + Antenna Factor + Cable loss - PRM Factor.  
 2. If Peak Result complies with AV limit, AV Result is deemed to comply with AV limit.  
 3. Test setup: RBW: 1 MHz, VBW: 3 MHz, Sweep time: auto.

# TR-4-E-009 Radiated Emission Test Result

<b>Test Site</b>	: DDT 3m Chamber 1#	D:\2017 RE1# Report Data\Q17112903-1E\Q17112904-1E FCC 1G-18G 5G WIFI .EM6
<b>Test Date</b>	: 2018-01-05	<b>Tested By</b> : Sunny
<b>EUT</b>	: Wireless speaker	<b>Model Number</b> : ALLURE PORTABLE
<b>Power Supply</b>	: AC 120V/60Hz	<b>Test Mode</b> : TX mode
<b>Condition</b>	: Temp:24.5'C,Humi:55%, Press:100.1kPa	<b>Antenna/Distance</b> : 2016 HF907/3m/VERTICAL
<b>Memo</b>	: 11n40 5795MHz	

Data: 224

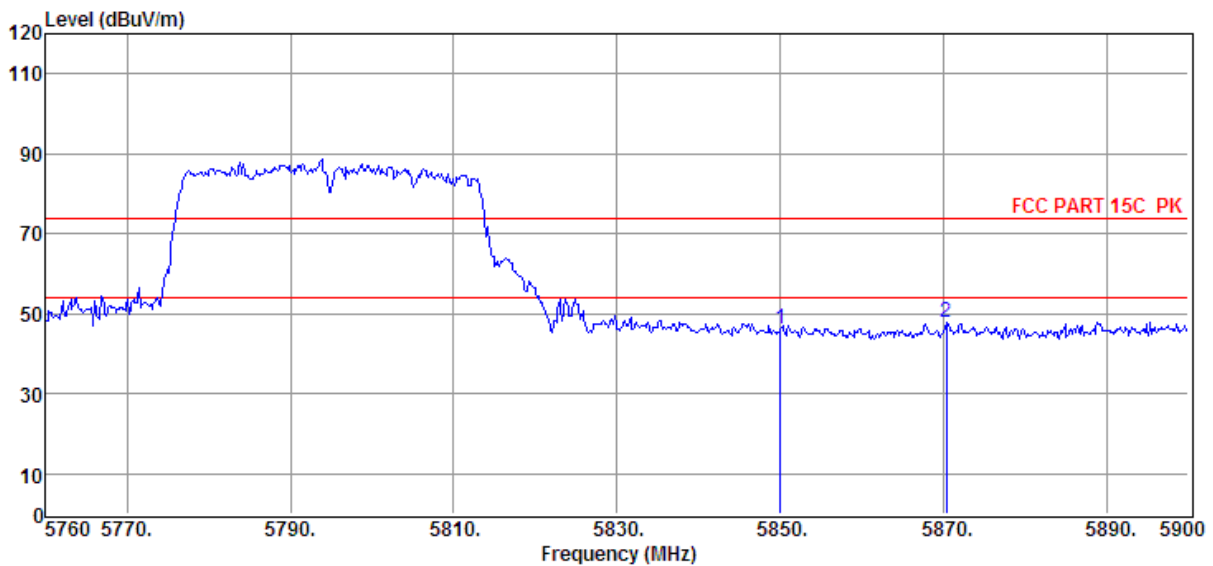

Item	Freq.	Read Level	Antenna Factor	PRM Factor	Cable Loss	Result Level	Limit Line	Over Limit	Detector	Polarization
(Mark)	(MHz)	(dBμV)	(dB/m)	dB	dB	(dBμV/m)	(dBμV/m)	(dB)		
1	5850.02	31.59	35.74	29.20	8.12	46.25	74.00	-27.75	Peak	VERTICAL
2	5870.32	33.11	35.75	29.20	8.13	47.79	74.00	-26.21	Peak	VERTICAL

Note: 1. Result Level = Read Level + Antenna Factor + Cable loss - PRM Factor.  
 2. If Peak Result complies with AV limit, AV Result is deemed to comply with AV limit.  
 3. Test setup: RBW: 1 MHz, VBW: 3 MHz, Sweep time: auto.

# TR-4-E-009 Radiated Emission Test Result

<b>Test Site</b>	: DDT 3m Chamber 1#	D:\2017 RE1# Report Data\Q17112903-1E\Q17112904-1E FCC 1G-18G 5G WIFI .EM6
<b>Test Date</b>	: 2018-01-05	<b>Tested By</b> : Sunny
<b>EUT</b>	: Wireless speaker	<b>Model Number</b> : ALLURE PORTABLE
<b>Power Supply</b>	: AC 120V/60Hz	<b>Test Mode</b> : TX mode
<b>Condition</b>	: Temp:24.5'C,Humi:55%, Press:100.1kPa	<b>Antenna/Distance</b> : 2016 HF907/3m/VERTICAL
<b>Memo</b>	: 11ac20 5180MHz	

Data: 225

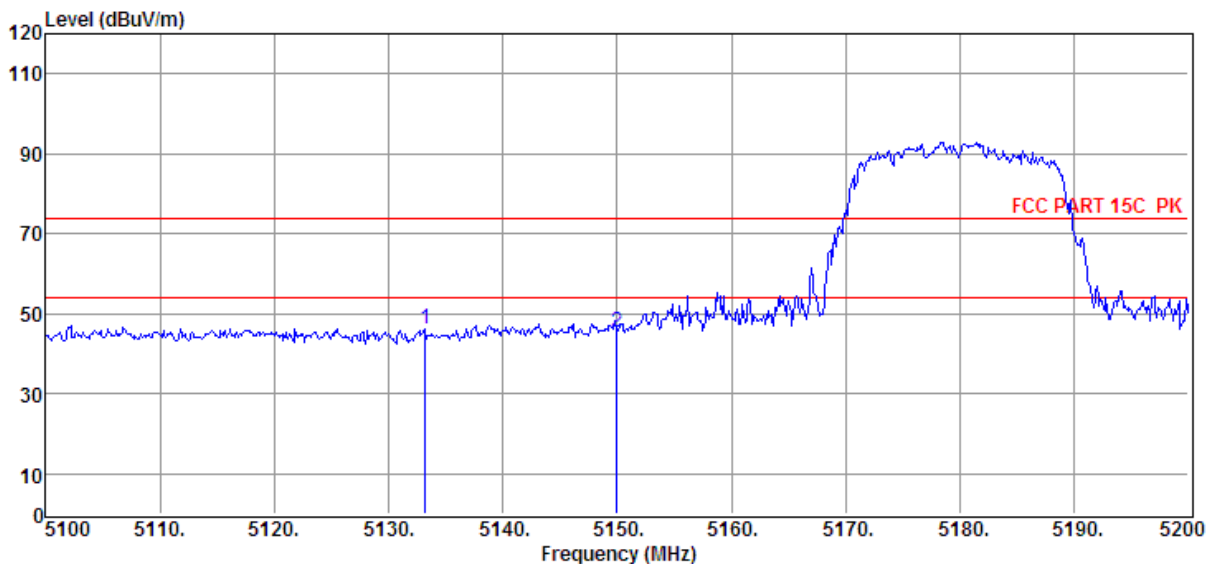

Item	Freq.	Read Level	Antenna Factor	PRM Factor	Cable Loss	Result Level	Limit Line	Over Limit	Detector	Polarization
(Mark)	(MHz)	(dBμV)	(dB/m)	dB	dB	(dBμV/m)	(dBμV/m)	(dB)		
1	5133.20	32.82	35.16	29.34	7.66	46.30	74.00	-27.70	Peak	VERTICAL
2	5150.00	31.70	35.18	29.33	7.67	45.22	74.00	-28.78	Peak	VERTICAL

Note: 1. Result Level = Read Level + Antenna Factor + Cable loss - PRM Factor.  
 2. If Peak Result complies with AV limit, AV Result is deemed to comply with AV limit.  
 3. Test setup: RBW: 1 MHz, VBW: 3 MHz, Sweep time: auto.

# TR-4-E-009 Radiated Emission Test Result

<b>Test Site</b>	: DDT 3m Chamber 1#	D:\2017 RE1# Report Data\Q17112903-1E\Q17112904-1E FCC 1G-18G 5G WIFI .EM6
<b>Test Date</b>	: 2018-01-05	<b>Tested By</b> : Sunny
<b>EUT</b>	: Wireless speaker	<b>Model Number</b> : ALLURE PORTABLE
<b>Power Supply</b>	: AC 120V/60Hz	<b>Test Mode</b> : TX mode
<b>Condition</b>	: Temp:24.5'C,Humi:55%, Press:100.1kPa	<b>Antenna/Distance</b> : 2016 HF907/3m/HORIZONTAL
<b>Memo</b>	: 11ac20 5180MHz	

Data: 226

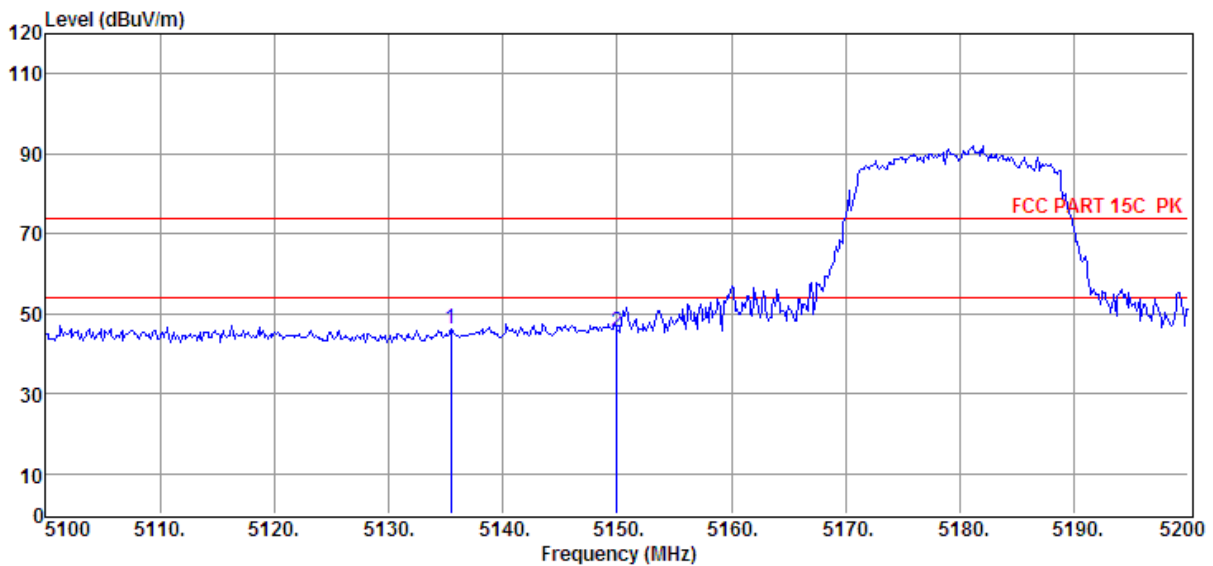

Item	Freq.	Read Level	Antenna Factor	PRM Factor	Cable Loss	Result Level	Limit Line	Over Limit	Detector	Polarization
(Mark)	(MHz)	(dBμV)	(dB/m)	dB	dB	(dBμV/m)	(dBμV/m)	(dB)		
1	5135.50	32.60	35.16	29.34	7.67	46.09	74.00	-27.91	Peak	HORIZONTAL
2	5150.00	31.79	35.18	29.33	7.67	45.31	74.00	-28.69	Peak	HORIZONTAL

- Note: 1. Result Level = Read Level + Antenna Factor + Cable loss - PRM Factor.  
 2. If Peak Result complies with AV limit, AV Result is deemed to comply with AV limit.  
 3. Test setup: RBW: 1 MHz, VBW: 3 MHz, Sweep time: auto.

# TR-4-E-009 Radiated Emission Test Result

<b>Test Site</b>	: DDT 3m Chamber 1#	D:\2017 RE1# Report Data\Q17112903-1E\Q17112904-1E FCC 1G-18G 5G WIFI .EM6
<b>Test Date</b>	: 2018-01-05	<b>Tested By</b> : Sunny
<b>EUT</b>	: Wireless speaker	<b>Model Number</b> : ALLURE PORTABLE
<b>Power Supply</b>	: AC 120V/60Hz	<b>Test Mode</b> : TX mode
<b>Condition</b>	: Temp:24.5'C,Humi:55%, Press:100.1kPa	<b>Antenna/Distance</b> : 2016 HF907/3m/VERTICAL
<b>Memo</b>	: 11ac20 5240MHz	

Data: 227

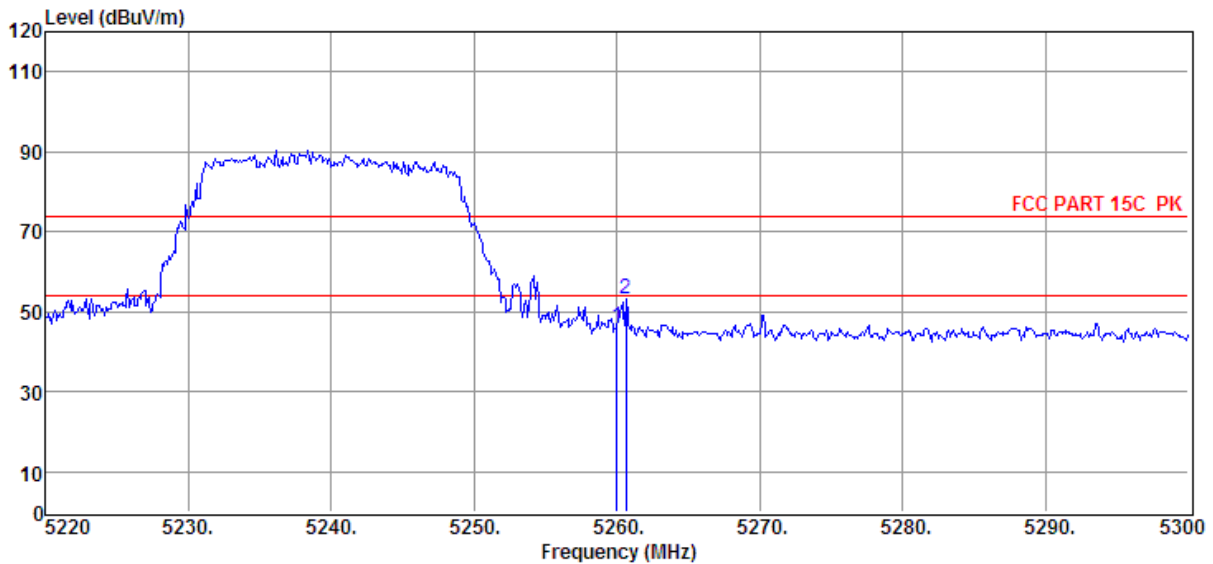

Item	Freq.	Read Level	Antenna Factor	PRM Factor	Cable Loss	Result Level	Limit Line	Over Limit	Detector	Polarization
(Mark)	(MHz)	(dBμV)	(dB/m)	dB	dB	(dBμV/m)	(dBμV/m)	(dB)		
1	5260.00	32.66	35.31	29.32	7.74	46.39	74.00	-27.61	Peak	VERTICAL
2	5260.64	39.28	35.31	29.32	7.74	53.01	74.00	-20.99	Peak	VERTICAL

Note: 1. Result Level = Read Level + Antenna Factor + Cable loss - PRM Factor.  
 2. If Peak Result complies with AV limit, AV Result is deemed to comply with AV limit.  
 3. Test setup: RBW: 1 MHz, VBW: 3 MHz, Sweep time: auto.

# TR-4-E-009 Radiated Emission Test Result

<b>Test Site</b>	: DDT 3m Chamber 1#	D:\2017 RE1# Report Data\Q17112903-1E\Q17112904-1E FCC 1G-18G 5G WIFI .EM6
<b>Test Date</b>	: 2018-01-05	<b>Tested By</b> : Sunny
<b>EUT</b>	: Wireless speaker	<b>Model Number</b> : ALLURE PORTABLE
<b>Power Supply</b>	: AC 120V/60Hz	<b>Test Mode</b> : TX mode
<b>Condition</b>	: Temp:24.5'C,Humi:55%, Press:100.1kPa	<b>Antenna/Distance</b> : 2016 HF907/3m/HORIZONTAL
<b>Memo</b>	: 11ac20 5240MHz	

Data: 228

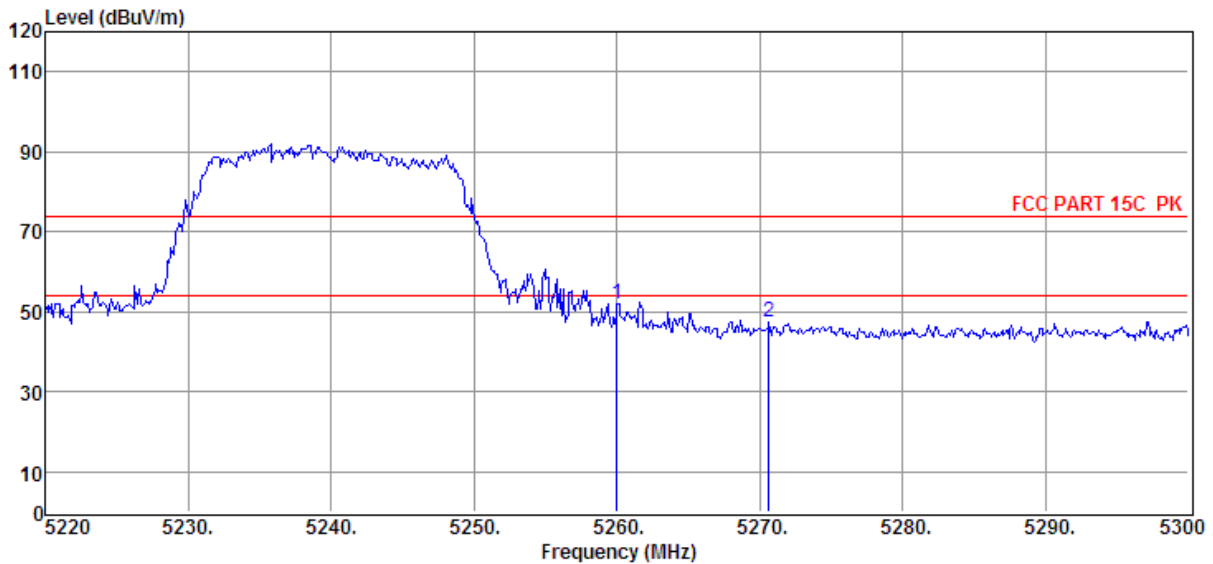

Item (Mark)	Freq. (MHz)	Read Level (dBμV)	Antenna Factor (dB/m)	PRM Facto r dB	Cable Loss dB	Result Level (dBμV/m)	Limit Line (dBμV/m)	Over Limit (dB)	Detector	Polarization
1	5260.00	38.24	35.31	29.32	7.74	51.97	74.00	-22.03	Peak	HORIZONTAL
2	5270.64	33.49	35.32	29.32	7.75	47.24	74.00	-26.76	Peak	HORIZONTAL

Note: 1. Result Level = Read Level + Antenna Factor + Cable loss - PRM Factor.  
 2. If Peak Result complies with AV limit, AV Result is deemed to comply with AV limit.  
 3. Test setup: RBW: 1 MHz, VBW: 3 MHz, Sweep time: auto.

# TR-4-E-009 Radiated Emission Test Result

<b>Test Site</b>	: DDT 3m Chamber 1#	D:\2017 RE1# Report Data\Q17112903-1E\Q17112904-1E FCC 1G-18G 5G WIFI .EM6
<b>Test Date</b>	: 2018-01-05	<b>Tested By</b> : Sunny
<b>EUT</b>	: Wireless speaker	<b>Model Number</b> : ALLURE PORTABLE
<b>Power Supply</b>	: AC 120V/60Hz	<b>Test Mode</b> : TX mode
<b>Condition</b>	: Temp:24.5'C,Humi:55%, Press:100.1kPa	<b>Antenna/Distance</b> : 2016 HF907/3m/HORIZONTAL
<b>Memo</b>	: 11ac20 5260MHz	

Data: 229

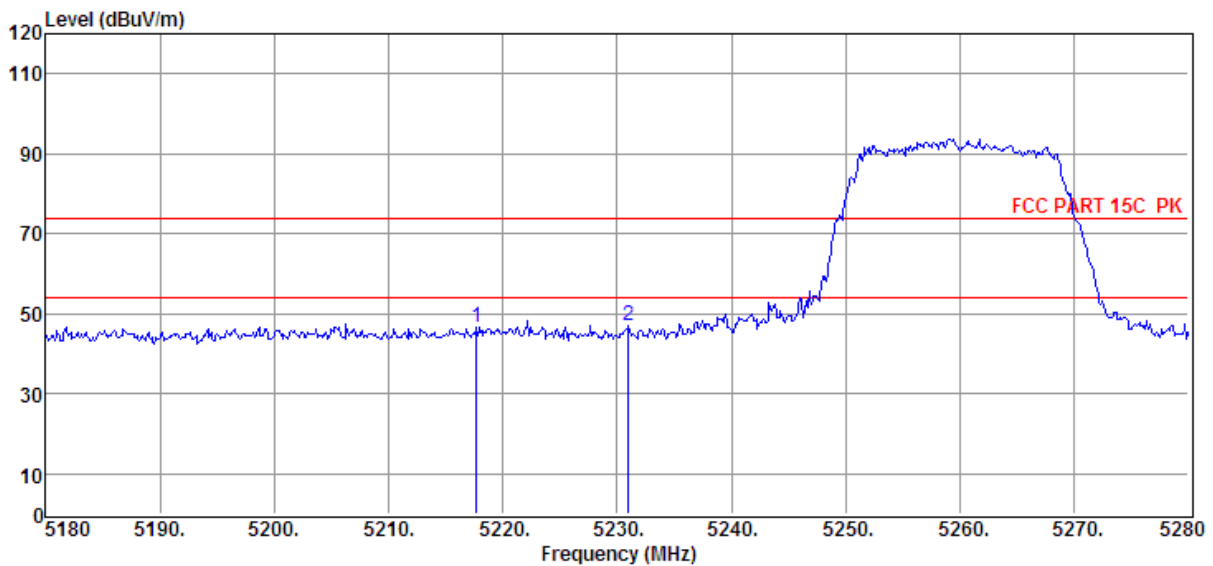

Item	Freq.	Read Level	Antenna Factor	PRM Factor	Cable Loss	Result Level	Limit Line	Over Limit	Detector	Polarization
(Mark)	(MHz)	(dBμV)	(dB/m)	dB	dB	(dBμV/m)	(dBμV/m)	(dB)		
1	5217.70	32.81	35.26	29.33	7.72	46.46	74.00	-27.54	Peak	HORIZONTAL
2	5231.00	33.24	35.28	29.32	7.73	46.93	74.00	-27.07	Peak	HORIZONTAL

Note: 1. Result Level = Read Level + Antenna Factor + Cable loss - PRM Factor.  
 2. If Peak Result complies with AV limit, AV Result is deemed to comply with AV limit.  
 3. Test setup: RBW: 1 MHz, VBW: 3 MHz, Sweep time: auto.

# TR-4-E-009 Radiated Emission Test Result

<b>Test Site</b>	: DDT 3m Chamber 1#	D:\2017 RE1# Report Data\Q17112903-1E\Q17112904-1E FCC 1G-18G 5G WIFI .EM6
<b>Test Date</b>	: 2018-01-05	<b>Tested By</b> : Sunny
<b>EUT</b>	: Wireless speaker	<b>Model Number</b> : ALLURE PORTABLE
<b>Power Supply</b>	: AC 120V/60Hz	<b>Test Mode</b> : TX mode
<b>Condition</b>	: Temp:24.5'C,Humi:55%, Press:100.1kPa	<b>Antenna/Distance</b> : 2016 HF907/3m/VERTICAL
<b>Memo</b>	: 11ac20 5260MHz	

Data: 230

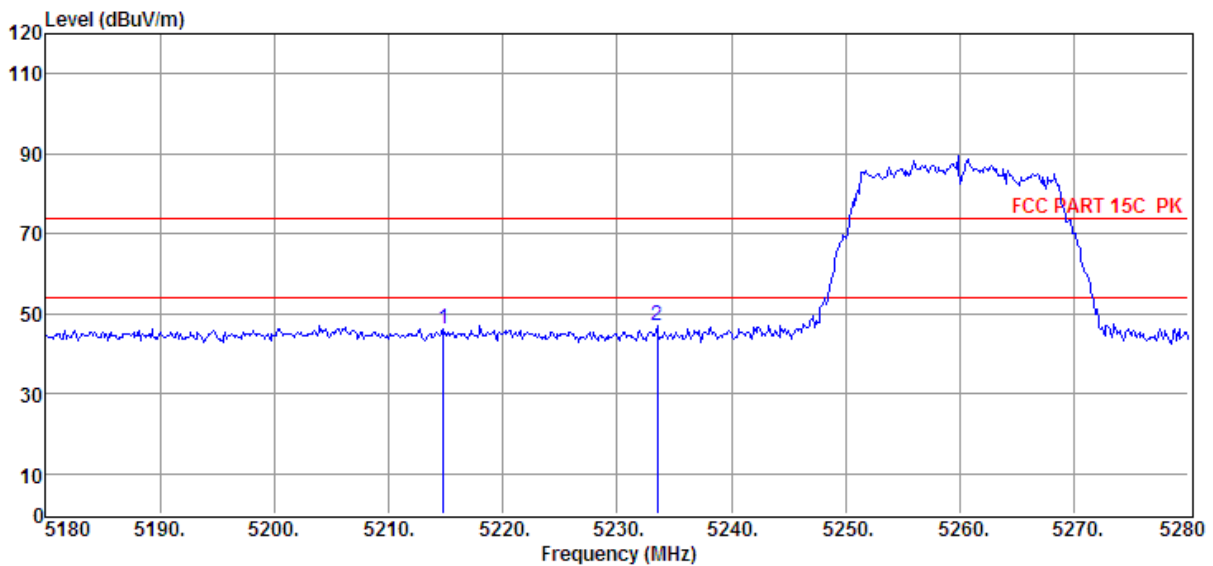

Item	Freq.	Read Level	Antenna Factor	PRM Factor	Cable Loss	Result Level	Limit Line	Over Limit	Detector	Polarization
(Mark)	(MHz)	(dBμV)	(dB/m)	dB	dB	(dBμV/m)	(dBμV/m)	(dB)		
1	5214.80	32.59	35.26	29.33	7.72	46.24	74.00	-27.76	Peak	VERTICAL
2	5233.50	33.43	35.28	29.32	7.73	47.12	74.00	-26.88	Peak	VERTICAL

Note: 1. Result Level = Read Level + Antenna Factor + Cable loss - PRM Factor.  
 2. If Peak Result complies with AV limit, AV Result is deemed to comply with AV limit.  
 3. Test setup: RBW: 1 MHz, VBW: 3 MHz, Sweep time: auto.

# TR-4-E-009 Radiated Emission Test Result

<b>Test Site</b>	: DDT 3m Chamber 1#	D:\2017 RE1# Report Data\Q17112903-1E\Q17112904-1E FCC 1G-18G 5G WIFI .EM6
<b>Test Date</b>	: 2018-01-05	<b>Tested By</b> : Sunny
<b>EUT</b>	: Wireless speaker	<b>Model Number</b> : ALLURE PORTABLE
<b>Power Supply</b>	: AC 120V/60Hz	<b>Test Mode</b> : TX mode
<b>Condition</b>	: Temp:24.5'C,Humi:55%, Press:100.1kPa	<b>Antenna/Distance</b> : 2016 HF907/3m/HORIZONTAL
<b>Memo</b>	: 11ac20 5320MHz	

Data: 231

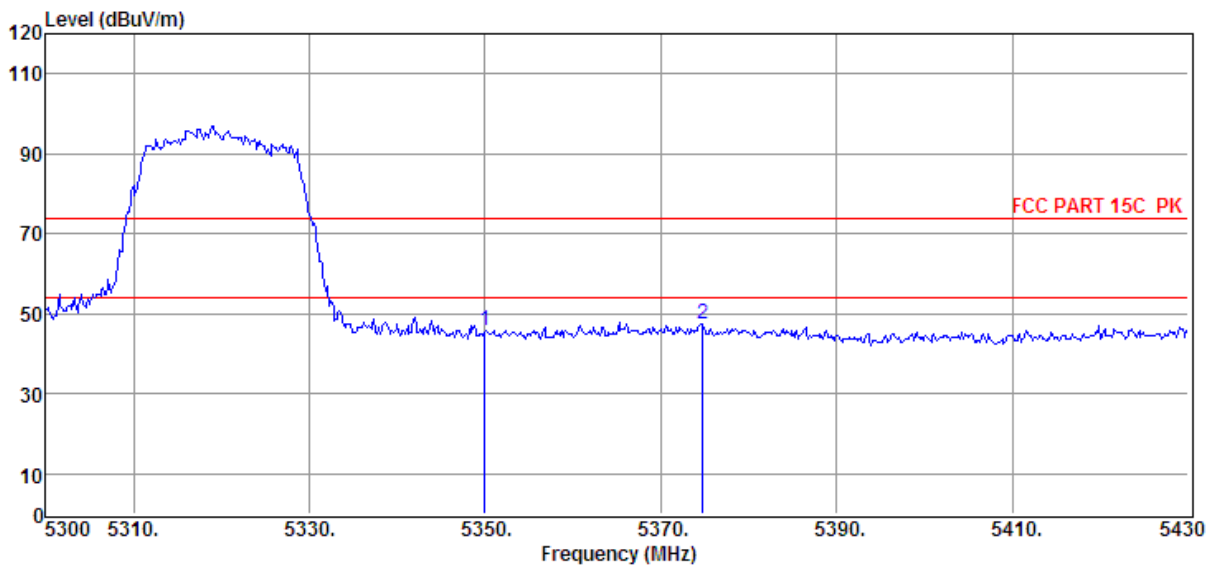

Item (Mark)	Freq. (MHz)	Read Level (dBμV)	Antenna Factor (dB/m)	PRM Facto r dB	Cable Loss dB	Result Level (dBμV/m)	Limit Line (dBμV/m)	Over Limit (dB)	Detector	Polarization
1	5350.00	31.86	35.42	29.30	7.80	45.78	74.00	-28.22	Peak	HORIZONTAL
2	5374.75	33.28	35.45	29.30	7.82	47.25	74.00	-26.75	Peak	HORIZONTAL

Note: 1. Result Level = Read Level + Antenna Factor + Cable loss - PRM Factor.  
 2. If Peak Result complies with AV limit, AV Result is deemed to comply with AV limit.  
 3. Test setup: RBW: 1 MHz, VBW: 3 MHz, Sweep time: auto.

# TR-4-E-009 Radiated Emission Test Result

<b>Test Site</b>	: DDT 3m Chamber 1#	<b>D:\2017 RE1# Report Data\Q17112903-1E\Q17112904-1E FCC 1G-18G 5G WIFI .EM6</b>
<b>Test Date</b>	: 2018-01-05	<b>Tested By</b> : Sunny
<b>EUT</b>	: Wireless speaker	<b>Model Number</b> : ALLURE PORTABLE
<b>Power Supply</b>	: AC 120V/60Hz	<b>Test Mode</b> : TX mode
<b>Condition</b>	: Temp:24.5'C,Humi:55%, Press:100.1kPa	<b>Antenna/Distance</b> : 2016 HF907/3m/VERTICAL
<b>Memo</b>	: 11ac20 5320MHz	

Data: 232

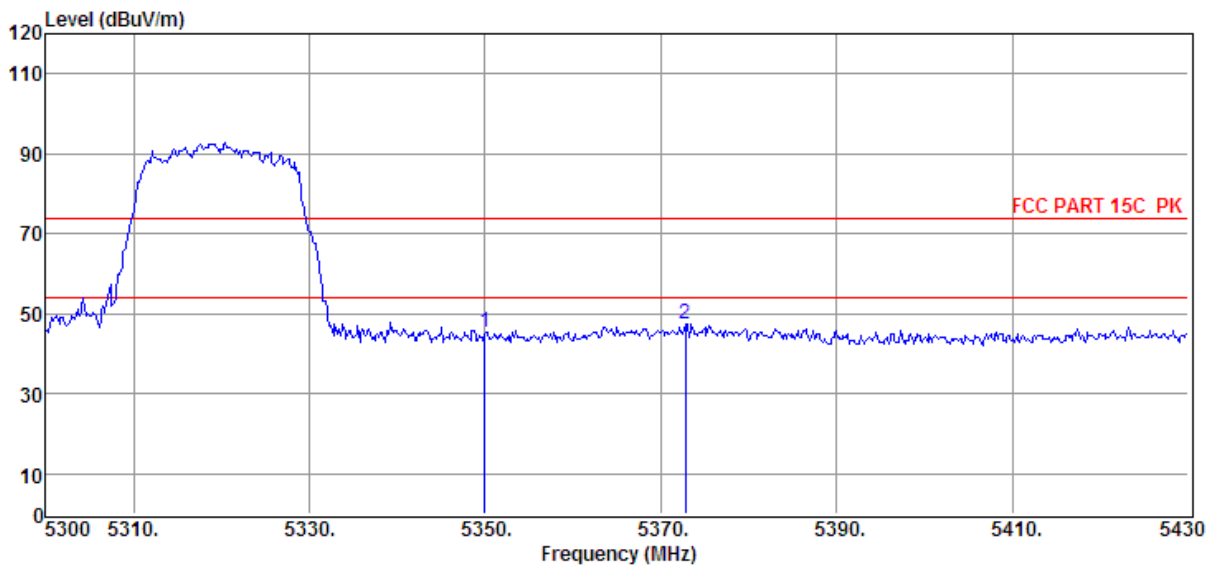

Item	Freq.	Read Level	Antenna Factor	PRM Factor	Cable Loss	Result Level	Limit Line	Over Limit	Detector	Polarization
(Mark)	(MHz)	(dBμV)	(dB/m)	dB	dB	(dBμV/m)	(dBμV/m)	(dB)		
1	5350.00	31.59	35.42	29.30	7.80	45.51	74.00	-28.49	Peak	VERTICAL
2	5372.80	33.38	35.45	29.30	7.81	47.34	74.00	-26.66	Peak	VERTICAL

- Note: 1. Result Level = Read Level + Antenna Factor + Cable loss - PRM Factor.  
 2. If Peak Result complies with AV limit, AV Result is deemed to comply with AV limit.  
 3. Test setup: RBW: 1 MHz, VBW: 3 MHz, Sweep time: auto.

# TR-4-E-009 Radiated Emission Test Result

<b>Test Site</b>	: DDT 3m Chamber 1#	D:\2017 RE1# Report Data\Q17112903-1E\Q17112904-1E FCC 1G-18G 5G WIFI .EM6
<b>Test Date</b>	: 2018-01-05	<b>Tested By</b> : Sunny
<b>EUT</b>	: Wireless speaker	<b>Model Number</b> : ALLURE PORTABLE
<b>Power Supply</b>	: AC 120V/60Hz	<b>Test Mode</b> : TX mode
<b>Condition</b>	: Temp:24.5'C,Humi:55%, Press:100.1kPa	<b>Antenna/Distance</b> : 2016 HF907/3m/VERTICAL
<b>Memo</b>	: 11ac20 5500MHz	

Data: 233

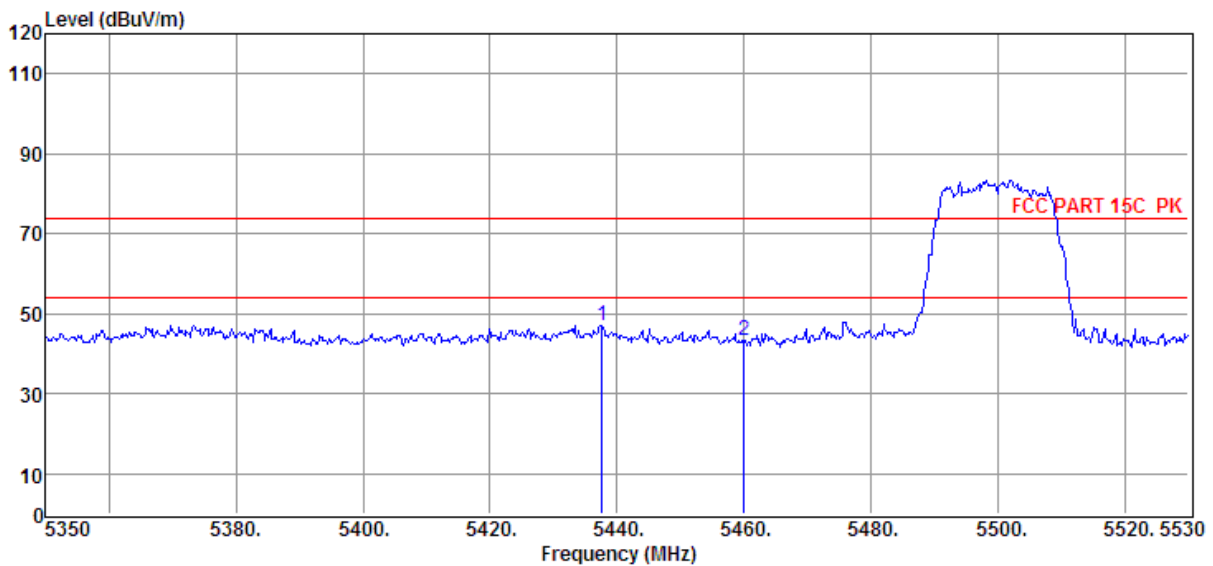

Item	Freq.	Read Level	Antenna Factor	PRM Factor	Cable Loss	Result Level	Limit Line	Over Limit	Detector	Polarization
(Mark)	(MHz)	(dBμV)	(dB/m)	dB	dB	(dBμV/m)	(dBμV/m)	(dB)		
1	5437.66	33.06	35.53	29.28	7.86	47.17	74.00	-26.83	Peak	VERTICAL
2	5460.00	29.03	35.55	29.28	7.87	43.17	74.00	-30.83	Peak	VERTICAL

Note: 1. Result Level = Read Level + Antenna Factor + Cable loss - PRM Factor.  
 2. If Peak Result complies with AV limit, AV Result is deemed to comply with AV limit.  
 3. Test setup: RBW: 1 MHz, VBW: 3 MHz, Sweep time: auto.

# TR-4-E-009 Radiated Emission Test Result

<b>Test Site</b>	: DDT 3m Chamber 1#	D:\2017 RE1# Report Data\Q17112903-1E\Q17112904-1E FCC 1G-18G 5G WIFI .EM6
<b>Test Date</b>	: 2018-01-05	<b>Tested By</b> : Sunny
<b>EUT</b>	: Wireless speaker	<b>Model Number</b> : ALLURE PORTABLE
<b>Power Supply</b>	: AC 120V/60Hz	<b>Test Mode</b> : TX mode
<b>Condition</b>	: Temp:24.5'C,Humi:55%, Press:100.1kPa	<b>Antenna/Distance</b> : 2016 HF907/3m/HORIZONTAL
<b>Memo</b>	: 11ac20 5500MHz	

Data: 234

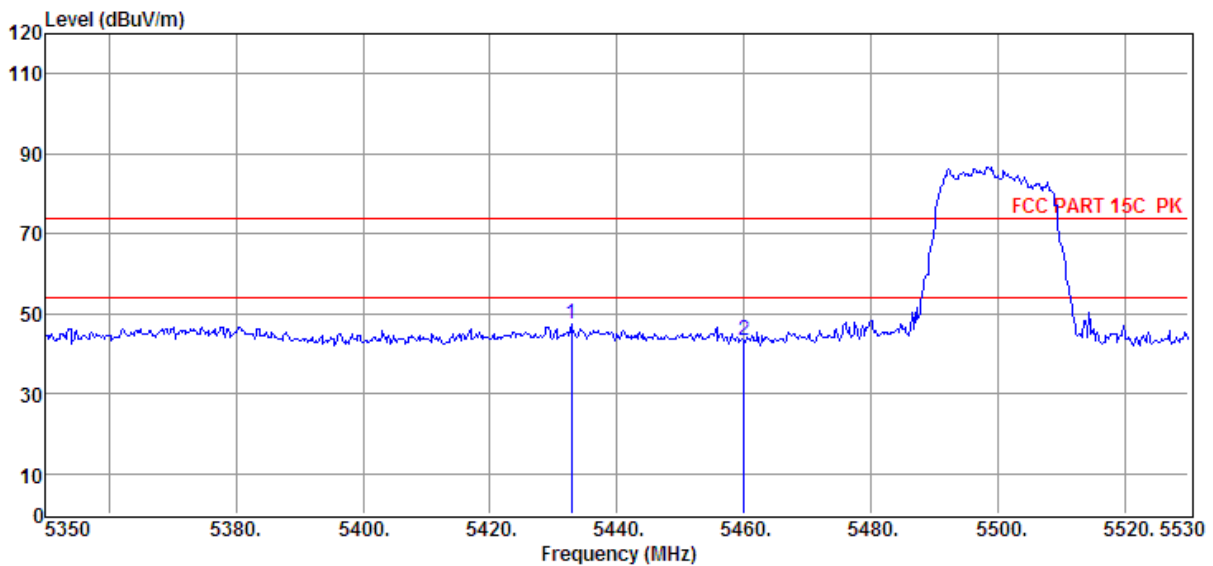

Item	Freq.	Read Level	Antenna Factor	PRM Factor	Cable Loss	Result Level	Limit Line	Over Limit	Detector	Polarization
(Mark)	(MHz)	(dBμV)	(dB/m)	dB	dB	(dBμV/m)	(dBμV/m)	(dB)		
1	5432.80	33.32	35.52	29.28	7.85	47.41	74.00	-26.59	Peak	HORIZONTAL
2	5460.00	29.16	35.55	29.28	7.87	43.30	74.00	-30.70	Peak	HORIZONTAL

Note: 1. Result Level = Read Level + Antenna Factor + Cable loss - PRM Factor.  
 2. If Peak Result complies with AV limit, AV Result is deemed to comply with AV limit.  
 3. Test setup: RBW: 1 MHz, VBW: 3 MHz, Sweep time: auto.

# TR-4-E-009 Radiated Emission Test Result

<b>Test Site</b>	: DDT 3m Chamber 1#	D:\2017 RE1# Report Data\Q17112903-1E\Q17112904-1E FCC 1G-18G 5G WIFI .EM6
<b>Test Date</b>	: 2018-01-05	<b>Tested By</b> : Sunny
<b>EUT</b>	: Wireless speaker	<b>Model Number</b> : ALLURE PORTABLE
<b>Power Supply</b>	: AC 120V/60Hz	<b>Test Mode</b> : TX mode
<b>Condition</b>	: Temp:24.5'C,Humi:55%, Press:100.1kPa	<b>Antenna/Distance</b> : 2016 HF907/3m/HORIZONTAL
<b>Memo</b>	: 11ac20 5700MHz	

Data: 235

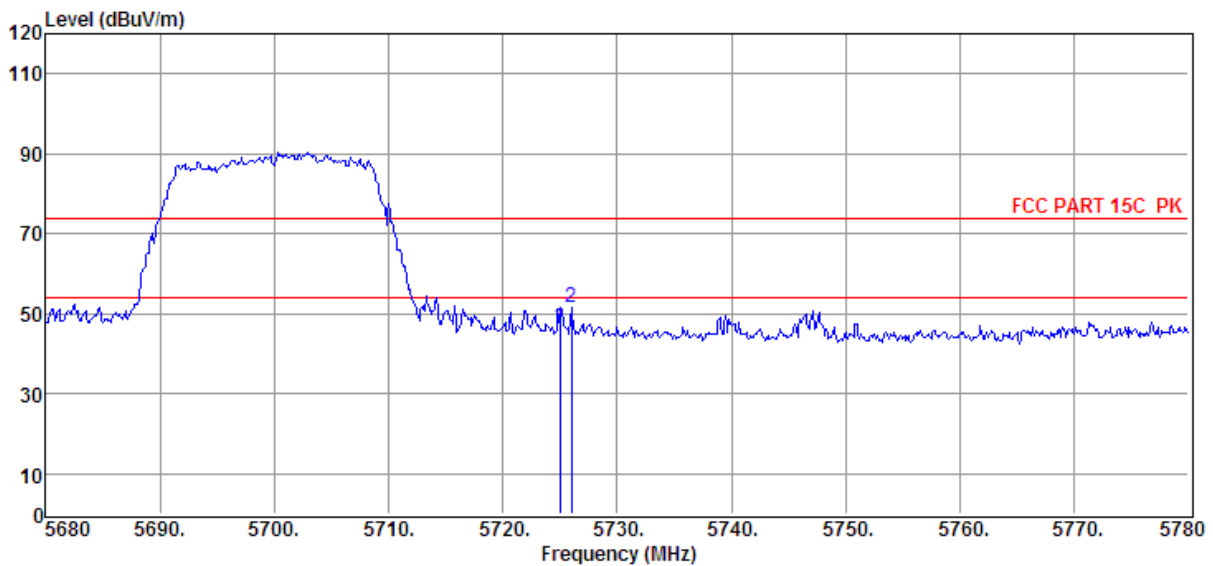

Item	Freq.	Read Level	Antenna Factor	PRM Factor	Cable Loss	Result Level	Limit Line	Over Limit	Detector	Polarization
(Mark)	(MHz)	(dBμV)	(dB/m)	dB	dB	(dBμV/m)	(dBμV/m)	(dB)		
1	5725.00	32.23	35.69	29.22	8.04	46.74	74.00	-27.26	Peak	HORIZONTAL
2	5726.00	37.22	35.69	29.22	8.04	51.73	74.00	-22.27	Peak	HORIZONTAL

Note: 1. Result Level = Read Level + Antenna Factor + Cable loss - PRM Factor.  
 2. If Peak Result complies with AV limit, AV Result is deemed to comply with AV limit.  
 3. Test setup: RBW: 1 MHz, VBW: 3 MHz, Sweep time: auto.

# TR-4-E-009 Radiated Emission Test Result

<b>Test Site</b>	: DDT 3m Chamber 1#	D:\2017 RE1# Report Data\Q17112903-1E\Q17112904-1E FCC 1G-18G 5G WIFI .EM6
<b>Test Date</b>	: 2018-01-05	<b>Tested By</b> : Sunny
<b>EUT</b>	: Wireless speaker	<b>Model Number</b> : ALLURE PORTABLE
<b>Power Supply</b>	: AC 120V/60Hz	<b>Test Mode</b> : TX mode
<b>Condition</b>	: Temp:24.5'C,Humi:55%, Press:100.1kPa	<b>Antenna/Distance</b> : 2016 HF907/3m/VERTICAL
<b>Memo</b>	: 11ac20 5700MHz	

Data: 236

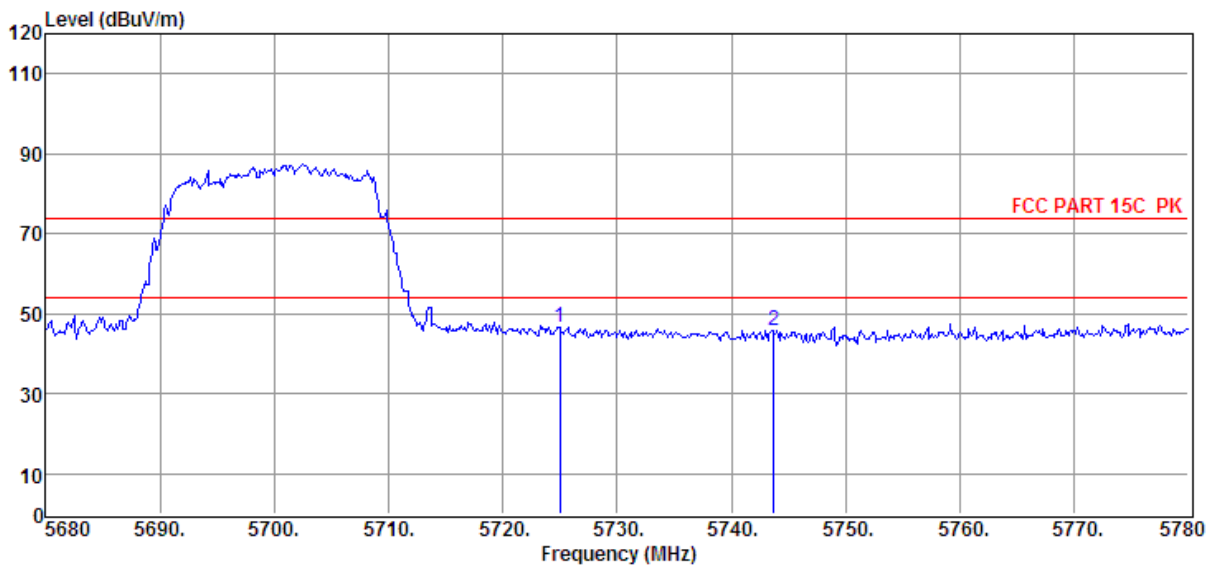

Item	Freq.	Read Level	Antenna Factor	PRM Factor	Cable Loss	Result Level	Limit Line	Over Limit	Detector	Polarization
(Mark)	(MHz)	(dBμV)	(dB/m)	dB	dB	(dBμV/m)	(dBμV/m)	(dB)		
1	5725.00	31.89	35.69	29.22	8.04	46.40	74.00	-27.60	Peak	VERTICAL
2	5743.70	31.29	35.70	29.21	8.05	45.83	74.00	-28.17	Peak	VERTICAL

Note: 1. Result Level = Read Level + Antenna Factor + Cable loss - PRM Factor.  
 2. If Peak Result complies with AV limit, AV Result is deemed to comply with AV limit.  
 3. Test setup: RBW: 1 MHz, VBW: 3 MHz, Sweep time: auto.

# TR-4-E-009 Radiated Emission Test Result

<b>Test Site</b>	: DDT 3m Chamber 1#	D:\2017 RE1# Report Data\Q17112903-1E\Q17112904-1E FCC 1G-18G 5G WIFI .EM6
<b>Test Date</b>	: 2018-01-05	<b>Tested By</b> : Sunny
<b>EUT</b>	: Wireless speaker	<b>Model Number</b> : ALLURE PORTABLE
<b>Power Supply</b>	: AC 120V/60Hz	<b>Test Mode</b> : TX mode
<b>Condition</b>	: Temp:24.5'C,Humi:55%, Press:100.1kPa	<b>Antenna/Distance</b> : 2016 HF907/3m/VERTICAL
<b>Memo</b>	: 11ac20 5745MHz	

Data: 237

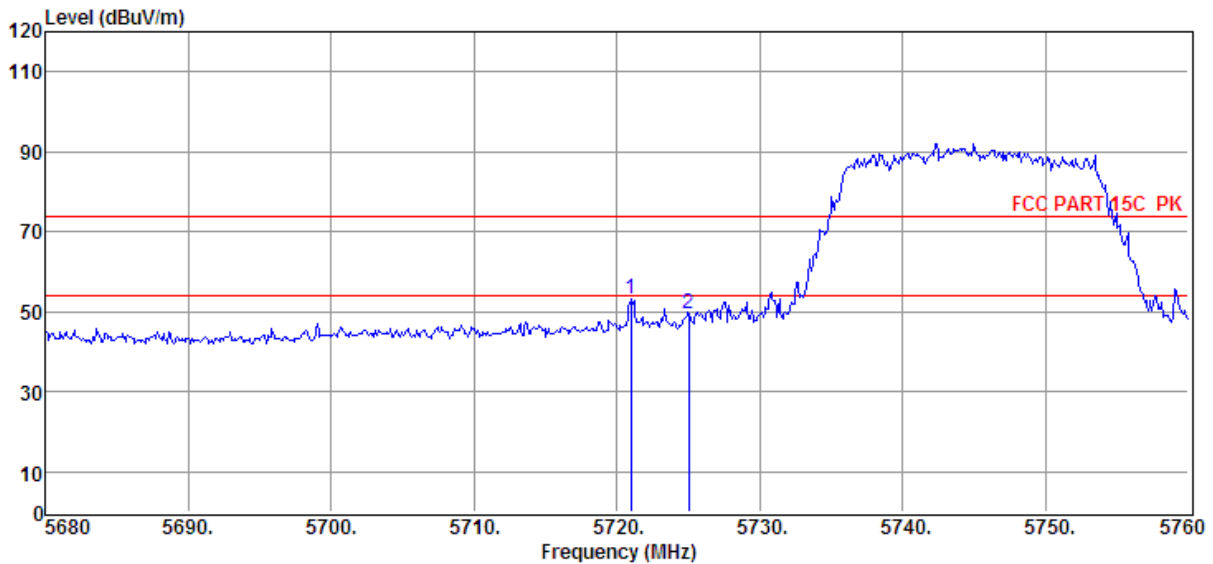

Item	Freq.	Read Level	Antenna Factor	PRM Factor	Cable Loss	Result Level	Limit Line	Over Limit	Detector	Polarization
(Mark)	(MHz)	(dBμV)	(dB/m)	dB	dB	(dBμV/m)	(dBμV/m)	(dB)		
1	5720.96	38.59	35.69	29.22	8.03	53.09	74.00	-20.91	Peak	VERTICAL
2	5725.00	34.93	35.69	29.22	8.04	49.44	74.00	-24.56	Peak	VERTICAL

Note: 1. Result Level = Read Level + Antenna Factor + Cable loss - PRM Factor.  
 2. If Peak Result complies with AV limit, AV Result is deemed to comply with AV limit.  
 3. Test setup: RBW: 1 MHz, VBW: 3 MHz, Sweep time: auto.

# TR-4-E-009 Radiated Emission Test Result

<b>Test Site</b>	: DDT 3m Chamber 1#	D:\2017 RE1# Report Data\Q17112903-1E\Q17112904-1E FCC 1G-18G 5G WIFI .EM6
<b>Test Date</b>	: 2018-01-05	<b>Tested By</b> : Sunny
<b>EUT</b>	: Wireless speaker	<b>Model Number</b> : ALLURE PORTABLE
<b>Power Supply</b>	: AC 120V/60Hz	<b>Test Mode</b> : TX mode
<b>Condition</b>	: Temp:24.5'C,Humi:55%, Press:100.1kPa	<b>Antenna/Distance</b> : 2016 HF907/3m/HORIZONTAL
<b>Memo</b>	: 11ac20 5745MHz	

Data: 238

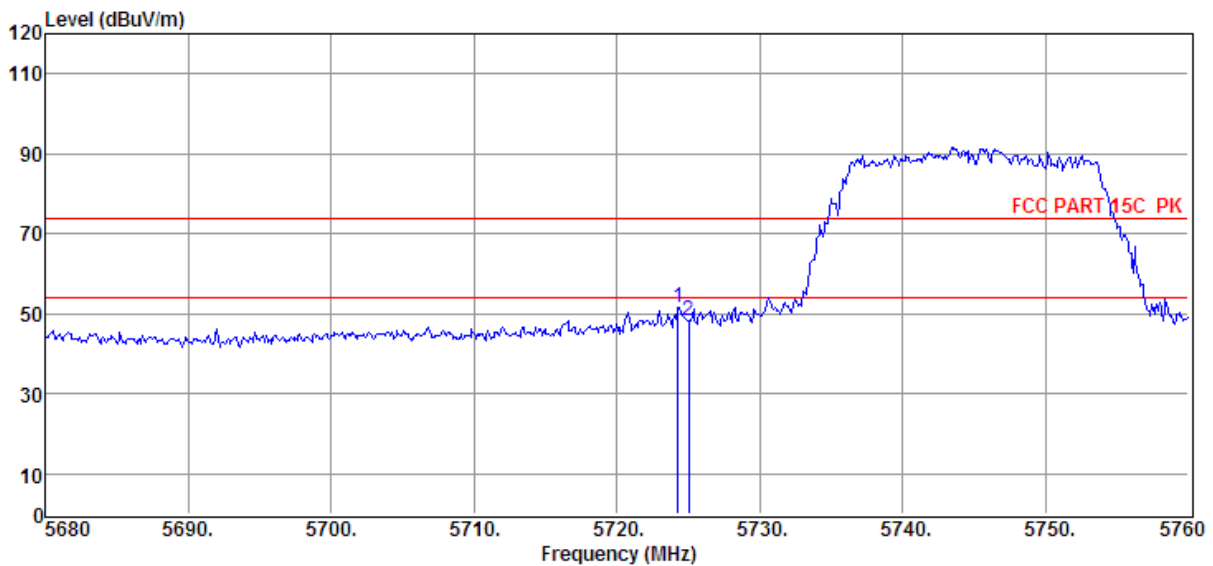

Item	Freq.	Read Level	Antenna Factor	PRM Factor	Cable Loss	Result Level	Limit Line	Over Limit	Detector	Polarization
(Mark)	(MHz)	(dBμV)	(dB/m)	dB	dB	(dBμV/m)	(dBμV/m)	(dB)		
1	5724.24	37.15	35.69	29.22	8.04	51.66	74.00	-22.34	Peak	HORIZONTAL
2	5725.00	33.57	35.69	29.22	8.04	48.08	74.00	-25.92	Peak	HORIZONTAL

Note: 1. Result Level = Read Level + Antenna Factor + Cable loss - PRM Factor.  
 2. If Peak Result complies with AV limit, AV Result is deemed to comply with AV limit.  
 3. Test setup: RBW: 1 MHz, VBW: 3 MHz, Sweep time: auto.

# TR-4-E-009 Radiated Emission Test Result

<b>Test Site</b>	: DDT 3m Chamber 1#	D:\2017 RE1# Report Data\Q17112903-1E\Q17112904-1E FCC 1G-18G 5G WIFI .EM6
<b>Test Date</b>	: 2018-01-05	<b>Tested By</b> : Sunny
<b>EUT</b>	: Wireless speaker	<b>Model Number</b> : ALLURE PORTABLE
<b>Power Supply</b>	: AC 120V/60Hz	<b>Test Mode</b> : TX mode
<b>Condition</b>	: Temp:24.5'C,Humi:55%, Press:100.1kPa	<b>Antenna/Distance</b> : 2016 HF907/3m/HORIZONTAL
<b>Memo</b>	: 11ac20 5825MHz	

Data: 239

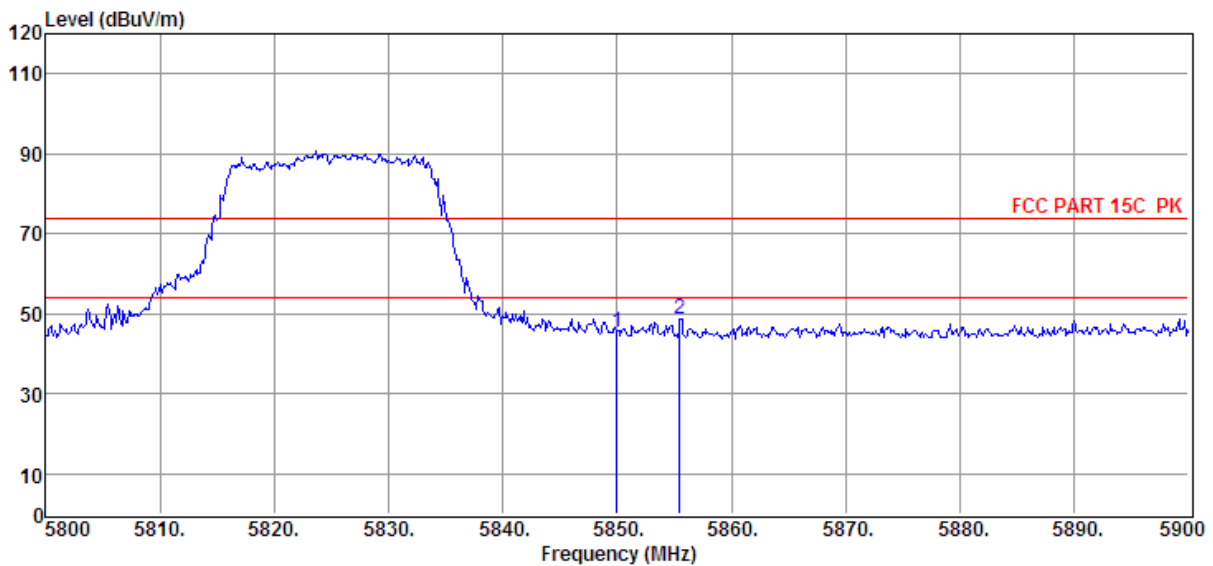

Item	Freq.	Read Level	Antenna Factor	PRM Factor	Cable Loss	Result Level	Limit Line	Over Limit	Detector	Polarization
(Mark)	(MHz)	(dBμV)	(dB/m)	dB	dB	(dBμV/m)	(dBμV/m)	(dB)		
1	5850.00	30.68	35.74	29.20	8.12	45.34	74.00	-28.66	Peak	HORIZONTAL
2	5855.50	33.88	35.74	29.20	8.12	48.54	74.00	-25.46	Peak	HORIZONTAL

Note: 1. Result Level = Read Level + Antenna Factor + Cable loss - PRM Factor.  
 2. If Peak Result complies with AV limit, AV Result is deemed to comply with AV limit.  
 3. Test setup: RBW: 1 MHz, VBW: 3 MHz, Sweep time: auto.

# TR-4-E-009 Radiated Emission Test Result

<b>Test Site</b>	: DDT 3m Chamber 1#	D:\2017 RE1# Report Data\Q17112903-1E\Q17112904-1E FCC 1G-18G 5G WIFI .EM6
<b>Test Date</b>	: 2018-01-05	<b>Tested By</b> : Sunny
<b>EUT</b>	: Wireless speaker	<b>Model Number</b> : ALLURE PORTABLE
<b>Power Supply</b>	: AC 120V/60Hz	<b>Test Mode</b> : TX mode
<b>Condition</b>	: Temp:24.5'C,Humi:55%, Press:100.1kPa	<b>Antenna/Distance</b> : 2016 HF907/3m/VERTICAL
<b>Memo</b>	: 11ac20 5825MHz	

Data: 240

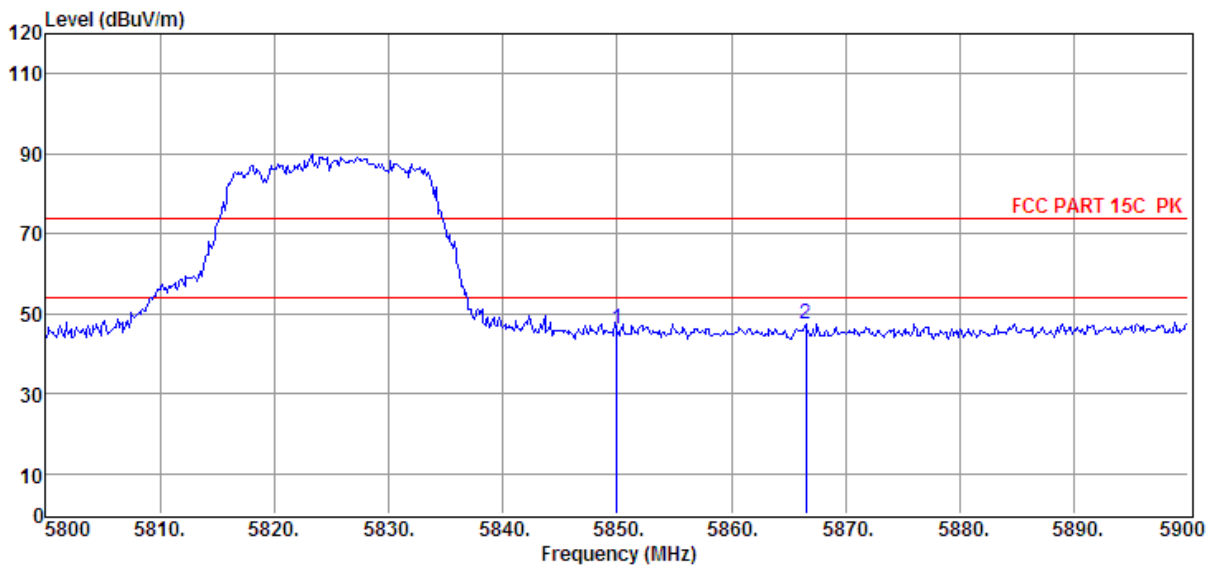

Item	Freq.	Read Level	Antenna Factor	PRM Factor	Cable Loss	Result Level	Limit Line	Over Limit	Detector	Polarization
(Mark)	(MHz)	(dBμV)	(dB/m)	dB	dB	(dBμV/m)	(dBμV/m)	(dB)		
1	5850.00	31.46	35.74	29.20	8.12	46.12	74.00	-27.88	Peak	VERTICAL
2	5866.50	32.84	35.75	29.20	8.13	47.52	74.00	-26.48	Peak	VERTICAL

Note: 1. Result Level = Read Level + Antenna Factor + Cable loss - PRM Factor.  
 2. If Peak Result complies with AV limit, AV Result is deemed to comply with AV limit.  
 3. Test setup: RBW: 1 MHz, VBW: 3 MHz, Sweep time: auto.

# TR-4-E-009 Radiated Emission Test Result

<b>Test Site</b>	: DDT 3m Chamber 1#	D:\2017 RE1# Report Data\Q17112903-1E\Q17112904-1E FCC 1G-18G 5G WIFI .EM6
<b>Test Date</b>	: 2018-01-05	<b>Tested By</b> : Sunny
<b>EUT</b>	: Wireless speaker	<b>Model Number</b> : ALLURE PORTABLE
<b>Power Supply</b>	: AC 120V/60Hz	<b>Test Mode</b> : TX mode
<b>Condition</b>	: Temp:24.5'C,Humi:55%, Press:100.1kPa	<b>Antenna/Distance</b> : 2016 HF907/3m/VERTICAL
<b>Memo</b>	: 11ac40 5190MHz	

Data: 241

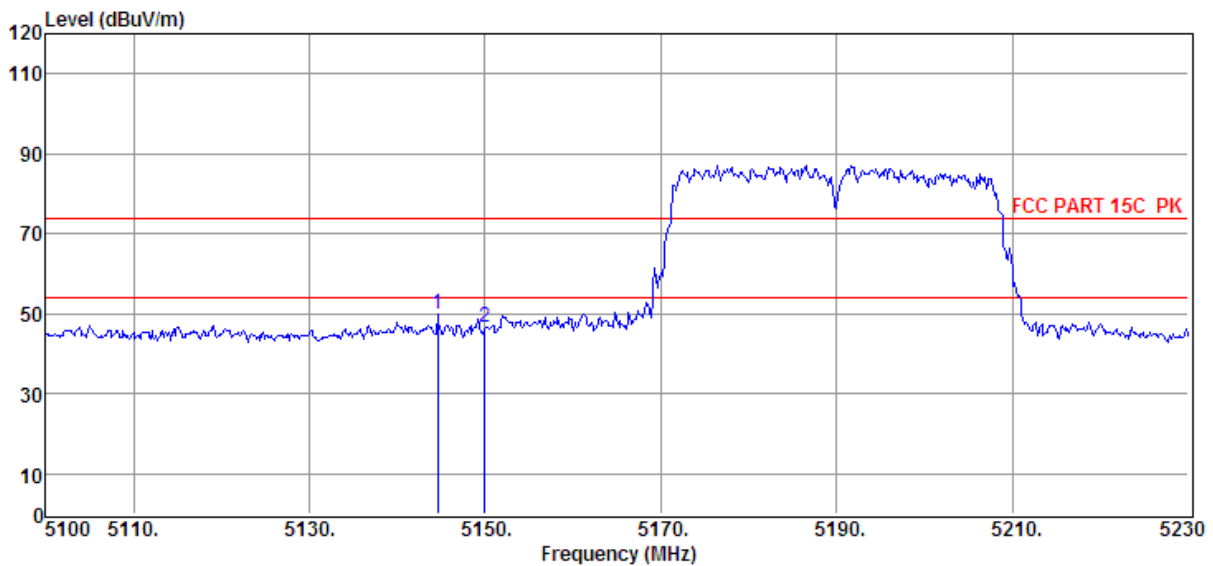

Item	Freq.	Read Level	Antenna Factor	PRM Factor	Cable Loss	Result Level	Limit Line	Over Limit	Detector	Polarization
(Mark)	(MHz)	(dBμV)	(dB/m)	dB	dB	(dBμV/m)	(dBμV/m)	(dB)		
1	5144.59	36.25	35.17	29.33	7.67	49.76	74.00	-24.24	Peak	VERTICAL
2	5150.00	33.20	35.18	29.33	7.67	46.72	74.00	-27.28	Peak	VERTICAL

- Note: 1. Result Level = Read Level + Antenna Factor + Cable loss - PRM Factor.  
 2. If Peak Result complies with AV limit, AV Result is deemed to comply with AV limit.  
 3. Test setup: RBW: 1 MHz, VBW: 3 MHz, Sweep time: auto.

# TR-4-E-009 Radiated Emission Test Result

<b>Test Site</b>	: DDT 3m Chamber 1#	D:\2017 RE1# Report Data\Q17112903-1E\Q17112904-1E FCC 1G-18G 5G WIFI .EM6
<b>Test Date</b>	: 2018-01-05	<b>Tested By</b> : Sunny
<b>EUT</b>	: Wireless speaker	<b>Model Number</b> : ALLURE PORTABLE
<b>Power Supply</b>	: AC 120V/60Hz	<b>Test Mode</b> : TX mode
<b>Condition</b>	: Temp:24.5'C,Humi:55%, Press:100.1kPa	<b>Antenna/Distance</b> : 2016 HF907/3m/HORIZONTAL
<b>Memo</b>	: 11ac40 5190MHz	

Data: 242

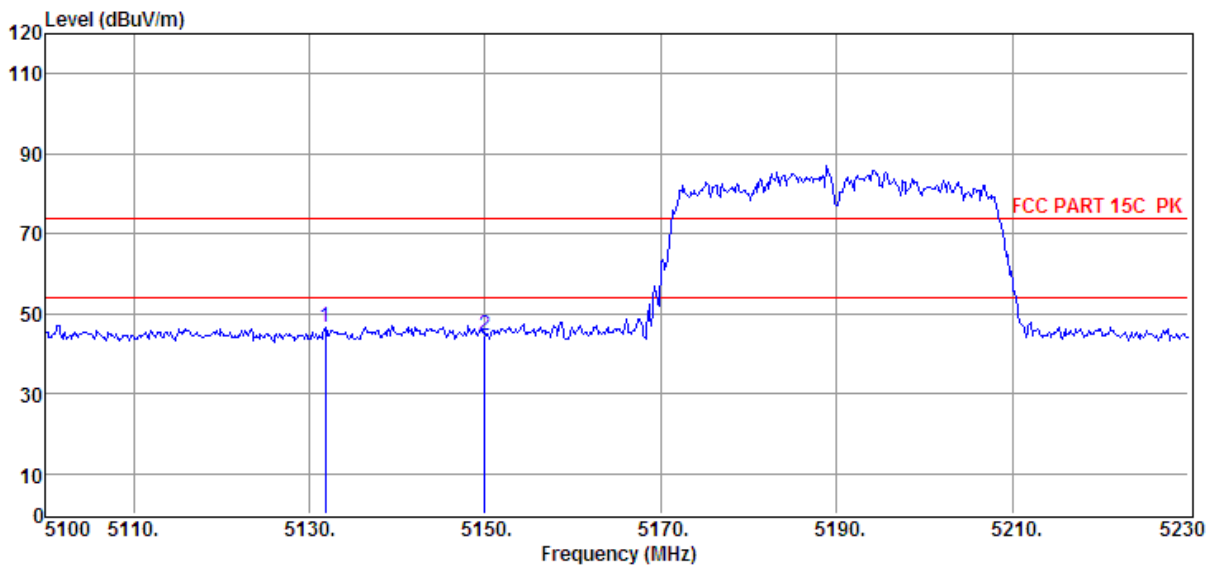

Item	Freq.	Read Level	Antenna Factor	PRM Factor	Cable Loss	Result Level	Limit Line	Over Limit	Detector	Polarization
(Mark)	(MHz)	(dBμV)	(dB/m)	dB	dB	(dBμV/m)	(dBμV/m)	(dB)		
1	5131.85	33.23	35.16	29.34	7.66	46.71	74.00	-27.29	Peak	HORIZONTAL
2	5150.00	31.04	35.18	29.33	7.67	44.56	74.00	-29.44	Peak	HORIZONTAL

- Note: 1. Result Level = Read Level + Antenna Factor + Cable loss - PRM Factor.  
 2. If Peak Result complies with AV limit, AV Result is deemed to comply with AV limit.  
 3. Test setup: RBW: 1 MHz, VBW: 3 MHz, Sweep time: auto.

# TR-4-E-009 Radiated Emission Test Result

<b>Test Site</b>	: DDT 3m Chamber 1#	D:\2017 RE1# Report Data\Q17112903-1E\Q17112904-1E FCC 1G-18G 5G WIFI .EM6
<b>Test Date</b>	: 2018-01-05	<b>Tested By</b> : Sunny
<b>EUT</b>	: Wireless speaker	<b>Model Number</b> : ALLURE PORTABLE
<b>Power Supply</b>	: AC 120V/60Hz	<b>Test Mode</b> : TX mode
<b>Condition</b>	: Temp:24.5'C,Humi:55%, Press:100.1kPa	<b>Antenna/Distance</b> : 2016 HF907/3m/VERTICAL
<b>Memo</b>	: 11ac40 5230MHz	

Data: 243

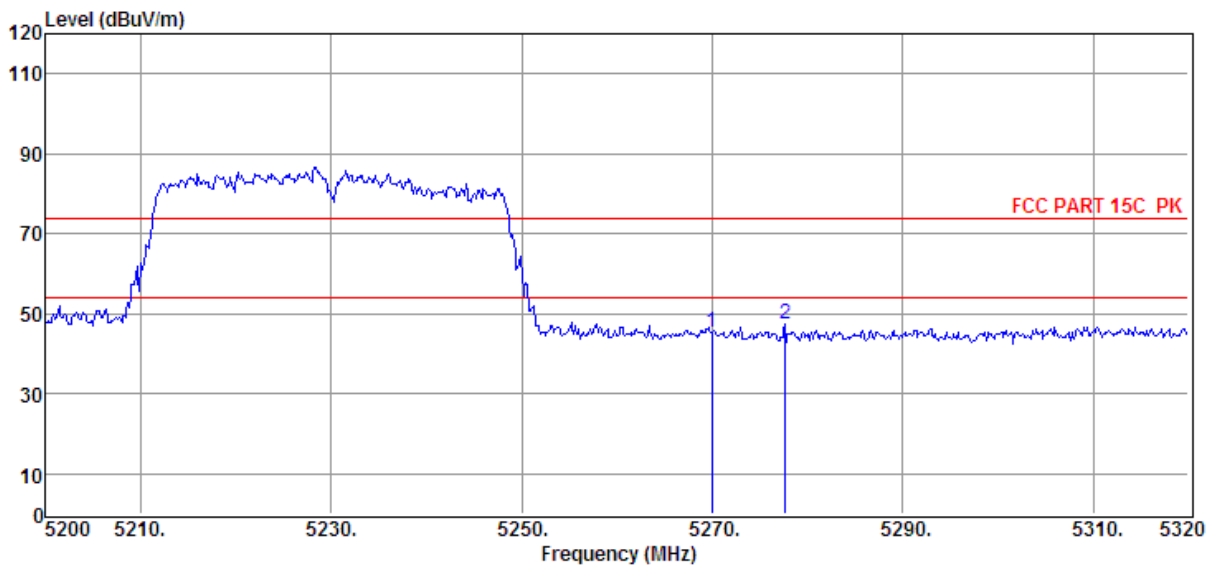

Item	Freq.	Read Level	Antenna Factor	PRM Factor	Cable Loss	Result Level	Limit Line	Over Limit	Detector	Polarization
(Mark)	(MHz)	(dBμV)	(dB/m)	dB	dB	(dBμV/m)	(dBμV/m)	(dB)		
1	5269.96	31.48	35.32	29.32	7.75	45.23	74.00	-28.77	Peak	VERTICAL
2	5277.64	33.67	35.33	29.31	7.75	47.44	74.00	-26.56	Peak	VERTICAL

Note: 1. Result Level = Read Level + Antenna Factor + Cable loss - PRM Factor.  
 2. If Peak Result complies with AV limit, AV Result is deemed to comply with AV limit.  
 3. Test setup: RBW: 1 MHz, VBW: 3 MHz, Sweep time: auto.

# TR-4-E-009 Radiated Emission Test Result

<b>Test Site</b>	: DDT 3m Chamber 1#	D:\2017 RE1# Report Data\Q17112903-1E\Q17112904-1E FCC 1G-18G 5G WIFI .EM6
<b>Test Date</b>	: 2018-01-05	<b>Tested By</b> : Sunny
<b>EUT</b>	: Wireless speaker	<b>Model Number</b> : ALLURE PORTABLE
<b>Power Supply</b>	: AC 120V/60Hz	<b>Test Mode</b> : TX mode
<b>Condition</b>	: Temp:24.5'C,Humi:55%, Press:100.1kPa	<b>Antenna/Distance</b> : 2016 HF907/3m/HORIZONTAL
<b>Memo</b>	: 11ac40 5230MHz	

Data: 244

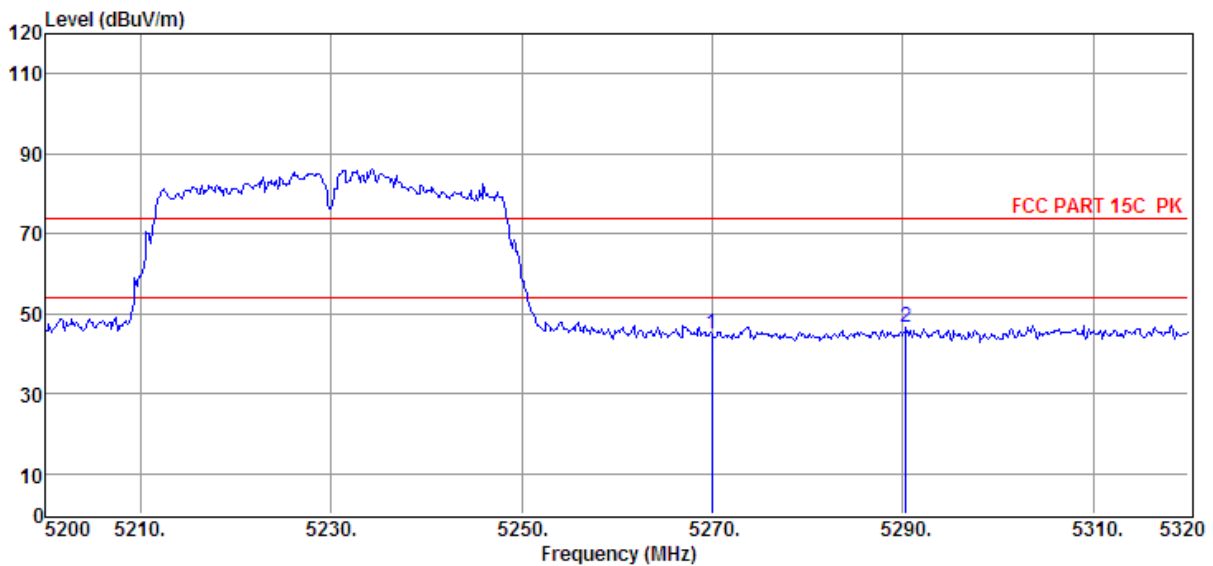

Item	Freq.	Read Level	Antenna Factor	PRM Factor	Cable Loss	Result Level	Limit Line	Over Limit	Detector	Polarization
(Mark)	(MHz)	(dBμV)	(dB/m)	dB	dB	(dBμV/m)	(dBμV/m)	(dB)		
1	5269.96	31.17	35.32	29.32	7.75	44.92	74.00	-29.08	Peak	HORIZONTAL
2	5290.36	32.76	35.35	29.31	7.76	46.56	74.00	-27.44	Peak	HORIZONTAL

- Note: 1. Result Level = Read Level + Antenna Factor + Cable loss - PRM Factor.  
 2. If Peak Result complies with AV limit, AV Result is deemed to comply with AV limit.  
 3. Test setup: RBW: 1 MHz, VBW: 3 MHz, Sweep time: auto.

# TR-4-E-009 Radiated Emission Test Result

<b>Test Site</b>	: DDT 3m Chamber 1#	D:\2017 RE1# Report Data\Q17112903-1E\Q17112904-1E FCC 1G-18G 5G WIFI .EM6
<b>Test Date</b>	: 2018-01-05	<b>Tested By</b> : Sunny
<b>EUT</b>	: Wireless speaker	<b>Model Number</b> : ALLURE PORTABLE
<b>Power Supply</b>	: AC 120V/60Hz	<b>Test Mode</b> : TX mode
<b>Condition</b>	: Temp:24.5'C,Humi:55%, Press:100.1kPa	<b>Antenna/Distance</b> : 2016 HF907/3m/HORIZONTAL
<b>Memo</b>	: 11ac40 5270MHz	

Data: 245

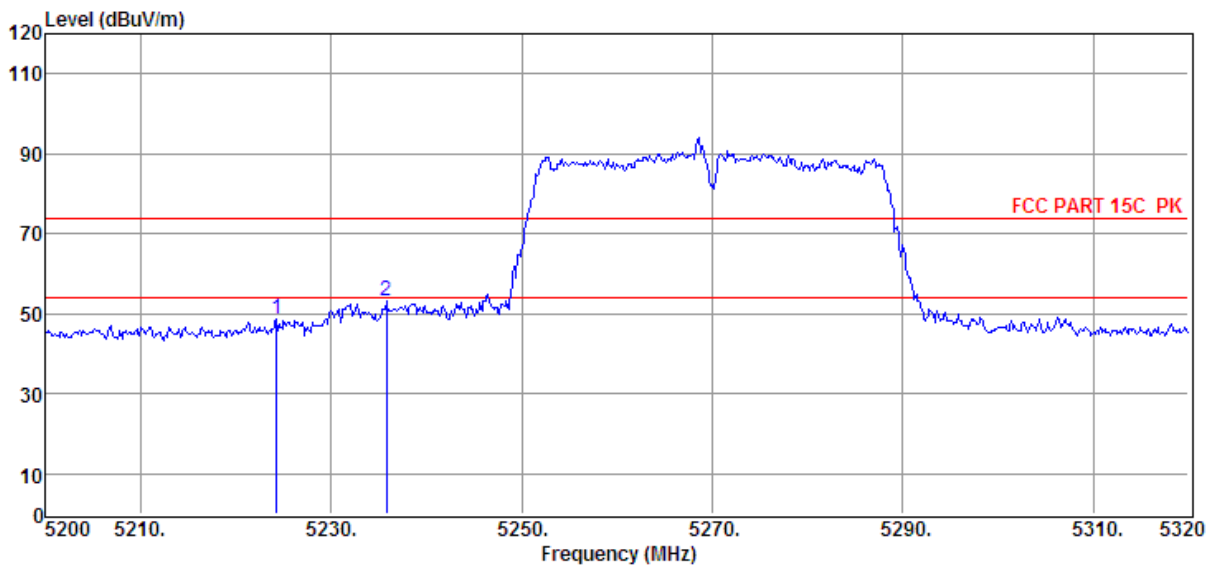

Item	Freq.	Read Level	Antenna Factor	PRM Factor	Cable Loss	Result Level	Limit Line	Over Limit	Detector	Polarization
(Mark)	(MHz)	(dBμV)	(dB/m)	dB	dB	(dBμV/m)	(dBμV/m)	(dB)		
1	5224.24	34.94	35.27	29.32	7.72	48.61	74.00	-25.39	Peak	HORIZONTAL
2	5235.76	39.54	35.28	29.32	7.73	53.23	74.00	-20.77	Peak	HORIZONTAL

Note: 1. Result Level = Read Level + Antenna Factor + Cable loss - PRM Factor.  
 2. If Peak Result complies with AV limit, AV Result is deemed to comply with AV limit.  
 3. Test setup: RBW: 1 MHz, VBW: 3 MHz, Sweep time: auto.

# TR-4-E-009 Radiated Emission Test Result

<b>Test Site</b>	: DDT 3m Chamber 1#	D:\2017 RE1# Report Data\Q17112903-1E\Q17112904-1E FCC 1G-18G 5G WIFI .EM6
<b>Test Date</b>	: 2018-01-05	<b>Tested By</b> : Sunny
<b>EUT</b>	: Wireless speaker	<b>Model Number</b> : ALLURE PORTABLE
<b>Power Supply</b>	: AC 120V/60Hz	<b>Test Mode</b> : TX mode
<b>Condition</b>	: Temp:24.5'C,Humi:55%, Press:100.1kPa	<b>Antenna/Distance</b> : 2016 HF907/3m/VERTICAL
<b>Memo</b>	: 11ac40 5270MHz	

Data: 246

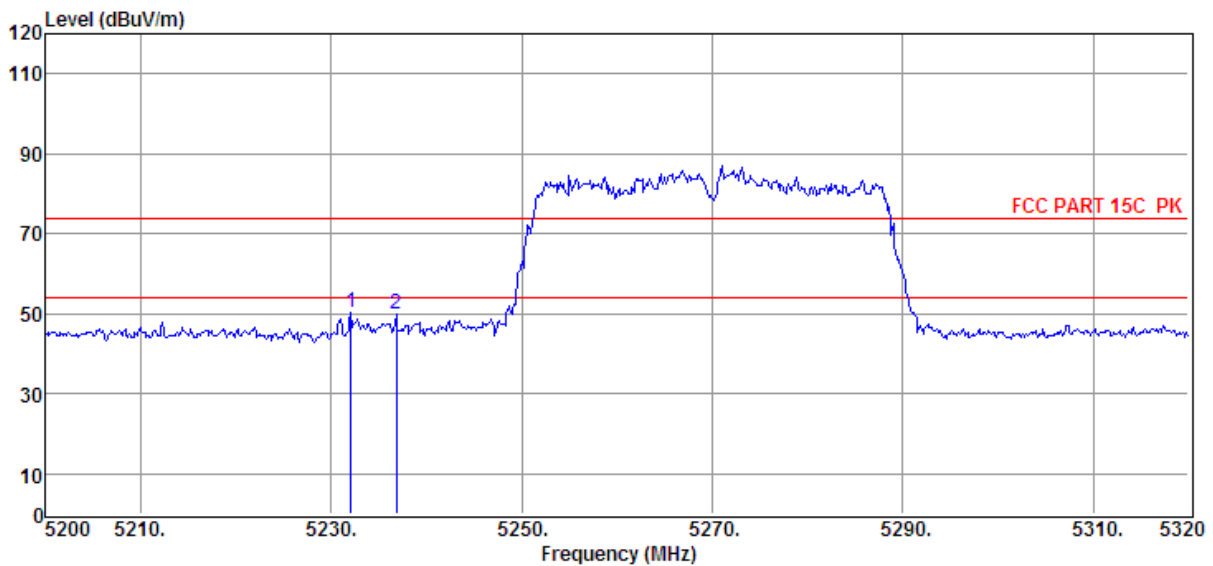

Item	Freq.	Read Level	Antenna Factor	PRM Factor	Cable Loss	Result Level	Limit Line	Over Limit	Detector	Polarization
(Mark)	(MHz)	(dBμV)	(dB/m)	dB	dB	(dBμV/m)	(dBμV/m)	(dB)		
1	5232.04	36.58	35.28	29.32	7.73	50.27	74.00	-23.73	Peak	VERTICAL
2	5236.84	36.10	35.28	29.32	7.73	49.79	74.00	-24.21	Peak	VERTICAL

- Note: 1. Result Level = Read Level + Antenna Factor + Cable loss - PRM Factor.  
 2. If Peak Result complies with AV limit, AV Result is deemed to comply with AV limit.  
 3. Test setup: RBW: 1 MHz, VBW: 3 MHz, Sweep time: auto.

# TR-4-E-009 Radiated Emission Test Result

<b>Test Site</b>	: DDT 3m Chamber 1#	D:\2017 RE1# Report Data\Q17112903-1E\Q17112904-1E FCC 1G-18G 5G WIFI .EM6
<b>Test Date</b>	: 2018-01-09	<b>Tested By</b> : Sunny
<b>EUT</b>	: Wireless speaker	<b>Model Number</b> : ALLURE PORTABLE
<b>Power Supply</b>	: AC 120V/60Hz	<b>Test Mode</b> : TX mode
<b>Condition</b>	: Temp:24.5'C,Humi:55%, Press:100.1kPa	<b>Antenna/Distance</b> : 2016 HF907/3m/VERTICAL
<b>Memo</b>	: 11ac40 5310MHz	

Data: 247

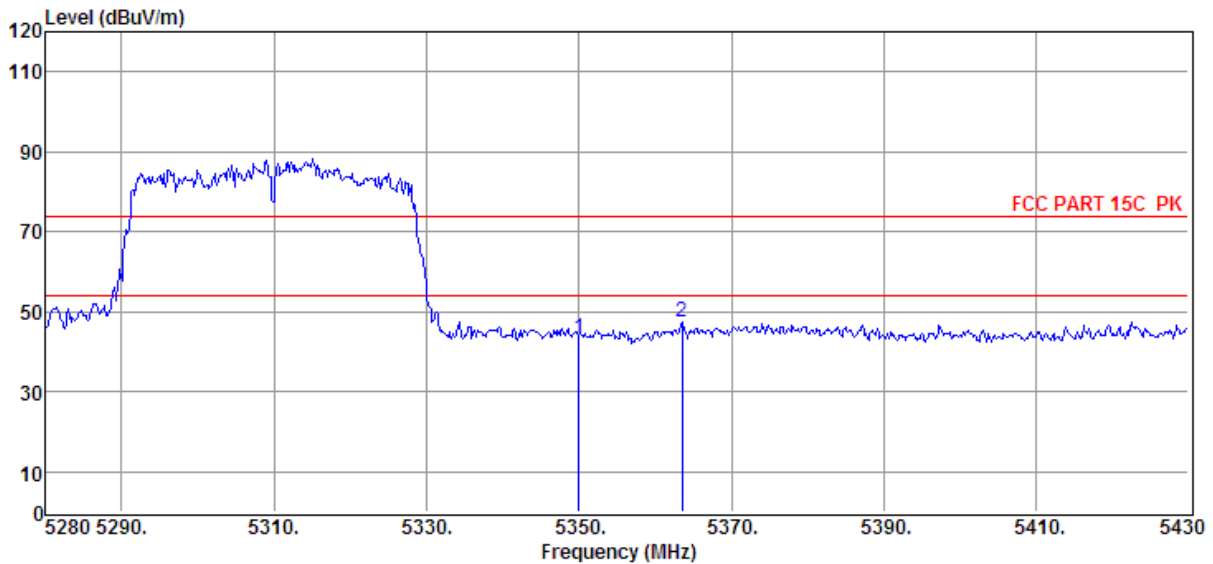

Item	Freq.	Read Level	Antenna Factor	PRM Factor	Cable Loss	Result Level	Limit Line	Over Limit	Detector	Polarization
(Mark)	(MHz)	(dBμV)	(dB/m)	dB	dB	(dBμV/m)	(dBμV/m)	(dB)		
1	5350.00	29.55	35.42	29.30	7.80	43.47	74.00	-30.53	Peak	VERTICAL
2	5363.55	33.60	35.44	29.30	7.81	47.55	74.00	-26.45	Peak	VERTICAL

- Note: 1. Result Level = Read Level + Antenna Factor + Cable loss - PRM Factor.  
 2. If Peak Result complies with AV limit, AV Result is deemed to comply with AV limit.  
 3. Test setup: RBW: 1 MHz, VBW: 3 MHz, Sweep time: auto.

# TR-4-E-009 Radiated Emission Test Result

<b>Test Site</b>	: DDT 3m Chamber 1#	D:\2017 RE1# Report Data\Q17112903-1E\Q17112904-1E
		FCC 1G-18G 5G WIFI .EM6
<b>Test Date</b>	: 2018-01-09	<b>Tested By</b> : Sunny
<b>EUT</b>	: Wireless speaker	<b>Model Number</b> : ALLURE PORTABLE
<b>Power Supply</b>	: AC 120V/60Hz	<b>Test Mode</b> : TX mode
<b>Condition</b>	: Temp:24.5'C,Humi:55%, Press:100.1kPa	<b>Antenna/Distance</b> : 2016 HF907/3m/HORIZONTAL
<b>Memo</b>	: 11ac40 5310MHz	

Data: 248

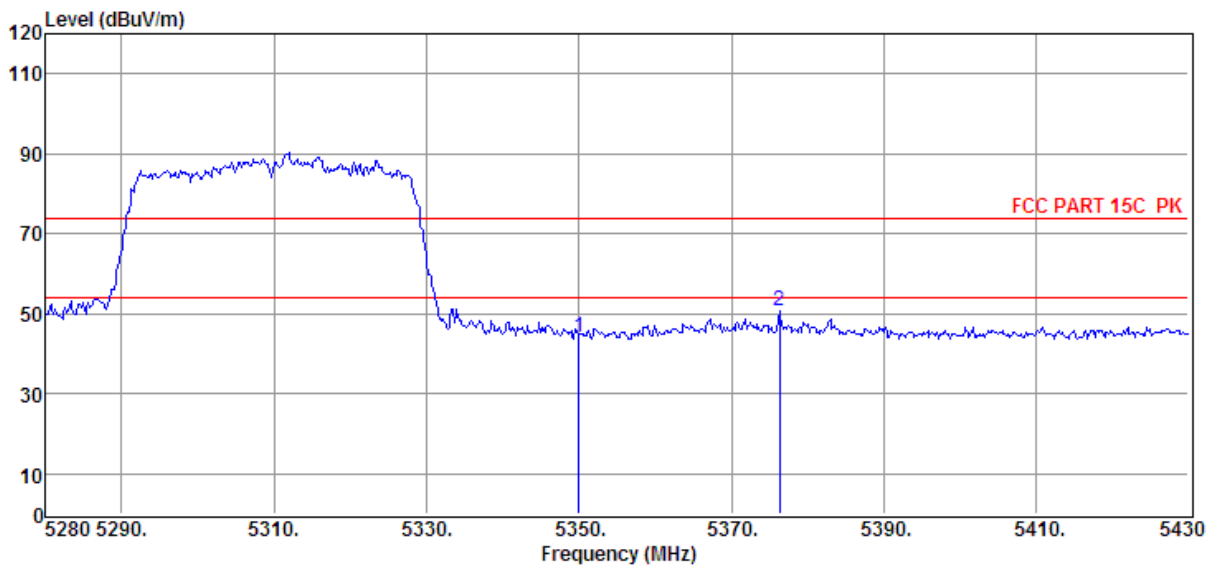

Item	Freq.	Read Level	Antenna Factor	PRM Factor	Cable Loss	Result Level	Limit Line	Over Limit	Detector	Polarization
(Mark)	(MHz)	(dBμV)	(dB/m)	dB	dB	(dBμV/m)	(dBμV/m)	(dB)		
1	5350.00	30.32	35.42	29.30	7.80	44.24	74.00	-29.76	Peak	HORIZONTAL
2	5376.30	36.58	35.45	29.30	7.82	50.55	74.00	-23.45	Peak	HORIZONTAL

Note: 1. Result Level = Read Level + Antenna Factor + Cable loss - PRM Factor.  
 2. If Peak Result complies with AV limit, AV Result is deemed to comply with AV limit.  
 3. Test setup: RBW: 1 MHz, VBW: 3 MHz, Sweep time: auto.

# TR-4-E-009 Radiated Emission Test Result

<b>Test Site</b>	: DDT 3m Chamber 1#	D:\2017 RE1# Report Data\Q17112903-1E\Q17112904-1E FCC 1G-18G 5G WIFI .EM6
<b>Test Date</b>	: 2018-01-09	<b>Tested By</b> : Sunny
<b>EUT</b>	: Wireless speaker	<b>Model Number</b> : ALLURE PORTABLE
<b>Power Supply</b>	: AC 120V/60Hz	<b>Test Mode</b> : TX mode
<b>Condition</b>	: Temp:24.5'C,Humi:55%, Press:100.1kPa	<b>Antenna/Distance</b> : 2016 HF907/3m/HORIZONTAL
<b>Memo</b>	: 11ac40 5510MHz	

Data: 249

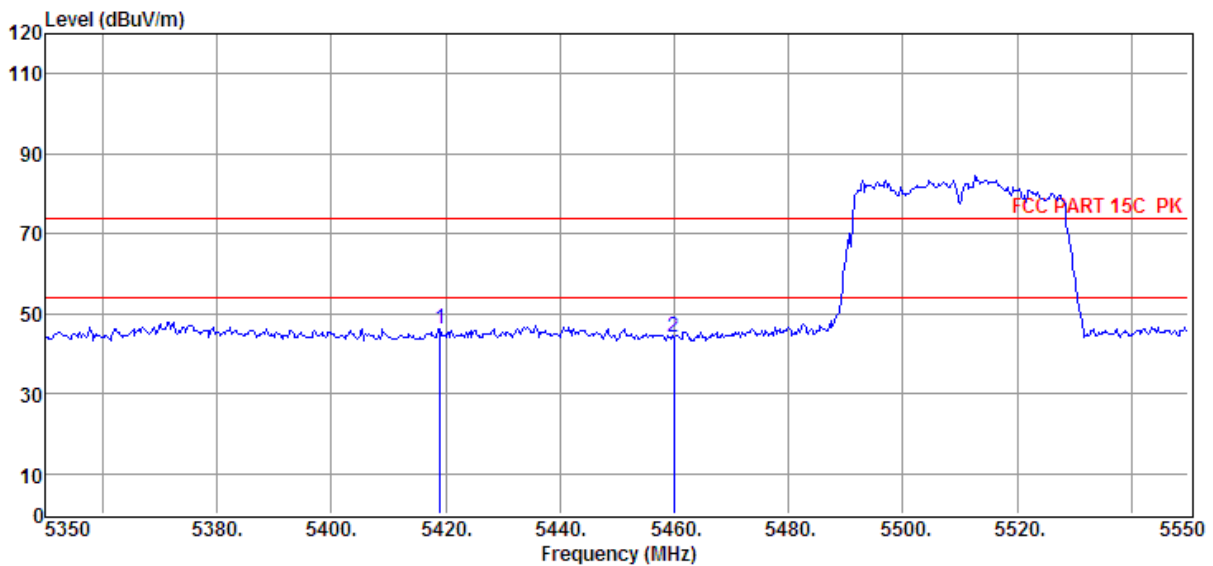

Item (Mark)	Freq. (MHz)	Read Level (dBμV)	Antenna Factor (dB/m)	PRM Facto r dB	Cable Loss dB	Result Level (dBμV/m)	Limit Line (dBμV/m)	Over Limit (dB)	Detector	Polarization
1	5419.00	32.24	35.50	29.28	7.84	46.30	74.00	-27.70	Peak	HORIZONTAL
2	5460.00	30.16	35.55	29.28	7.87	44.30	74.00	-29.70	Peak	HORIZONTAL

- Note: 1. Result Level = Read Level + Antenna Factor + Cable loss - PRM Factor.  
 2. If Peak Result complies with AV limit, AV Result is deemed to comply with AV limit.  
 3. Test setup: RBW: 1 MHz, VBW: 3 MHz, Sweep time: auto.

# TR-4-E-009 Radiated Emission Test Result

<b>Test Site</b>	: DDT 3m Chamber 1#	D:\2017 RE1# Report Data\Q17112903-1E\Q17112904-1E FCC 1G-18G 5G WIFI .EM6
<b>Test Date</b>	: 2018-01-09	<b>Tested By</b> : Sunny
<b>EUT</b>	: Wireless speaker	<b>Model Number</b> : ALLURE PORTABLE
<b>Power Supply</b>	: AC 120V/60Hz	<b>Test Mode</b> : TX mode
<b>Condition</b>	: Temp:24.5'C,Humi:55%, Press:100.1kPa	<b>Antenna/Distance</b> : 2016 HF907/3m/VERTICAL
<b>Memo</b>	: 11ac40 5510MHz	

Data: 250

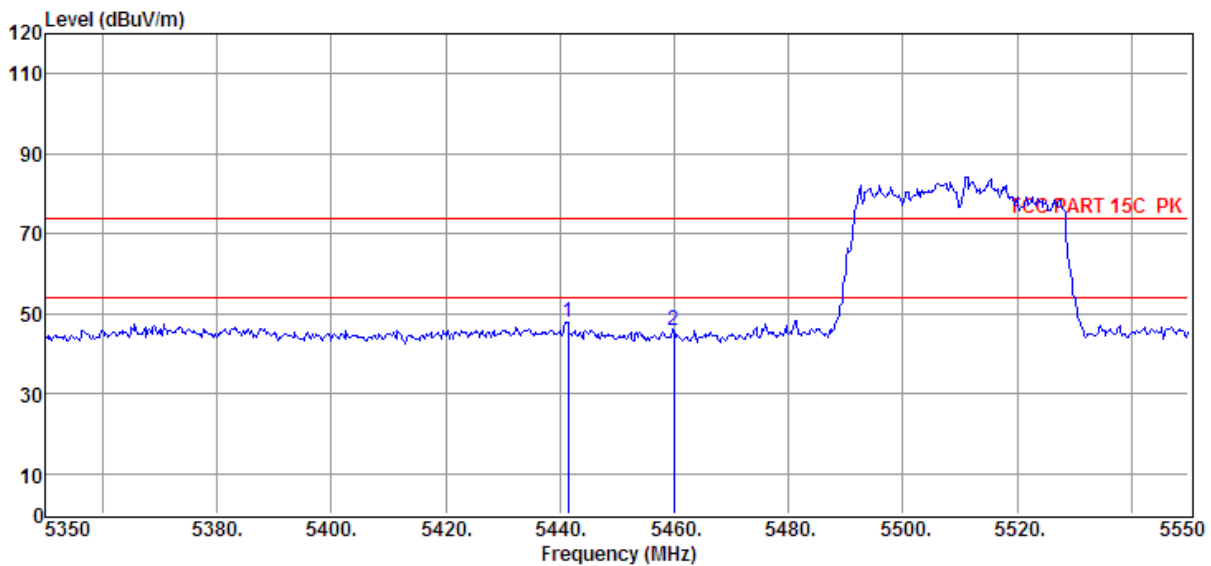

Item	Freq.	Read Level	Antenna Factor	PRM Factor	Cable Loss	Result Level	Limit Line	Over Limit	Detector	Polarization
(Mark)	(MHz)	(dBμV)	(dB/m)	dB	dB	(dBμV/m)	(dBμV/m)	(dB)		
1	5441.40	33.84	35.53	29.28	7.86	47.95	74.00	-26.05	Peak	VERTICAL
2	5460.00	31.50	35.55	29.28	7.87	45.64	74.00	-28.36	Peak	VERTICAL

Note: 1. Result Level = Read Level + Antenna Factor + Cable loss - PRM Factor.  
 2. If Peak Result complies with AV limit, AV Result is deemed to comply with AV limit.  
 3. Test setup: RBW: 1 MHz, VBW: 3 MHz, Sweep time: auto.

# TR-4-E-009 Radiated Emission Test Result

**Test Site** : DDT 3m Chamber 1# D:\2017 RE1# Report Data\Q17112903-1E\Q17112904-1E FCC 1G-18G 5G WIFI .EM6  
**Test Date** : 2018-01-09 **Tested By** : Sunny  
**EUT** : Wireless speaker **Model Number** : ALLURE PORTABLE  
**Power Supply** : AC 120V/60Hz **Test Mode** : TX mode  
**Condition** : Temp:24.5'C,Humi:55%,  
 Press:100.1kPa **Antenna/Distance** : 2016 HF907/3m/VERTICAL  
**Memo** : 11ac40 5670MHz

Data: 251

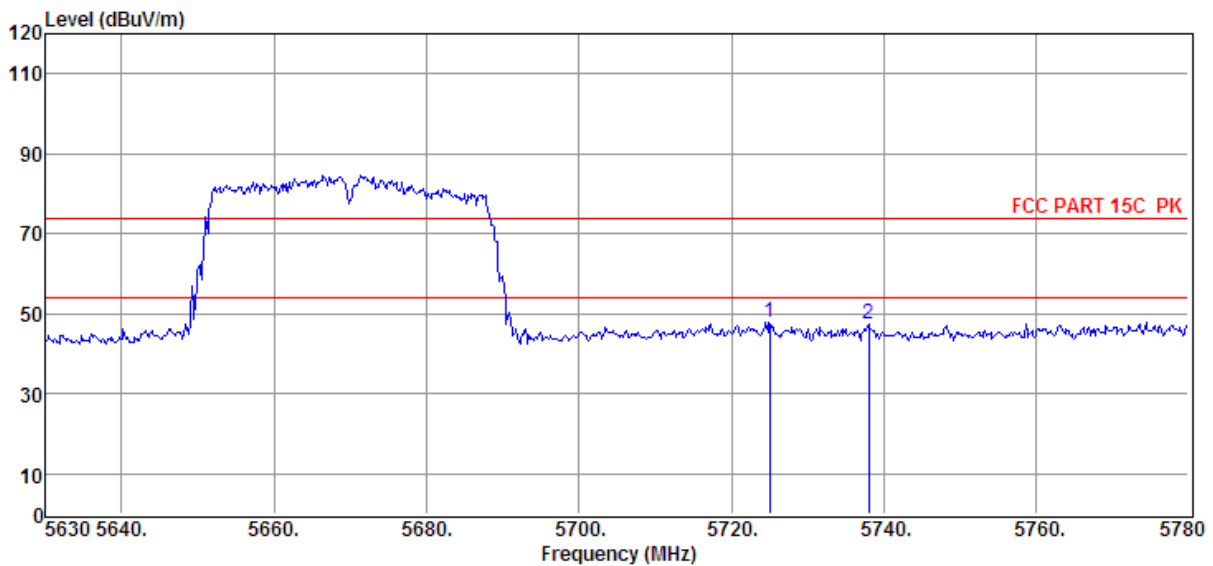

Item	Freq.	Read Level	Antenna Factor	PRM Factor	Cable Loss	Result Level	Limit Line	Over Limit	Detector	Polarization
(Mark)	(MHz)	(dBμV)	(dB/m)	dB	dB	(dBμV/m)	(dBμV/m)	(dB)		
1	5725.00	33.33	35.69	29.22	8.04	47.84	74.00	-26.16	Peak	VERTICAL
2	5738.00	32.82	35.70	29.21	8.04	47.35	74.00	-26.65	Peak	VERTICAL

- Note: 1. Result Level = Read Level + Antenna Factor + Cable loss - PRM Factor.  
 2. If Peak Result complies with AV limit, AV Result is deemed to comply with AV limit.  
 3. Test setup: RBW: 1 MHz, VBW: 3 MHz, Sweep time: auto.

# TR-4-E-009 Radiated Emission Test Result

<b>Test Site</b>	: DDT 3m Chamber 1#	D:\2017 RE1# Report Data\Q17112903-1E\Q17112904-1E
		FCC 1G-18G 5G WIFI .EM6
<b>Test Date</b>	: 2018-01-09	<b>Tested By</b> : Sunny
<b>EUT</b>	: Wireless speaker	<b>Model Number</b> : ALLURE PORTABLE
<b>Power Supply</b>	: AC 120V/60Hz	<b>Test Mode</b> : TX mode
<b>Condition</b>	: Temp:24.5'C,Humi:55%, Press:100.1kPa	<b>Antenna/Distance</b> : 2016 HF907/3m/HORIZONTAL
<b>Memo</b>	: 11ac40 5670MHz	

Data: 252

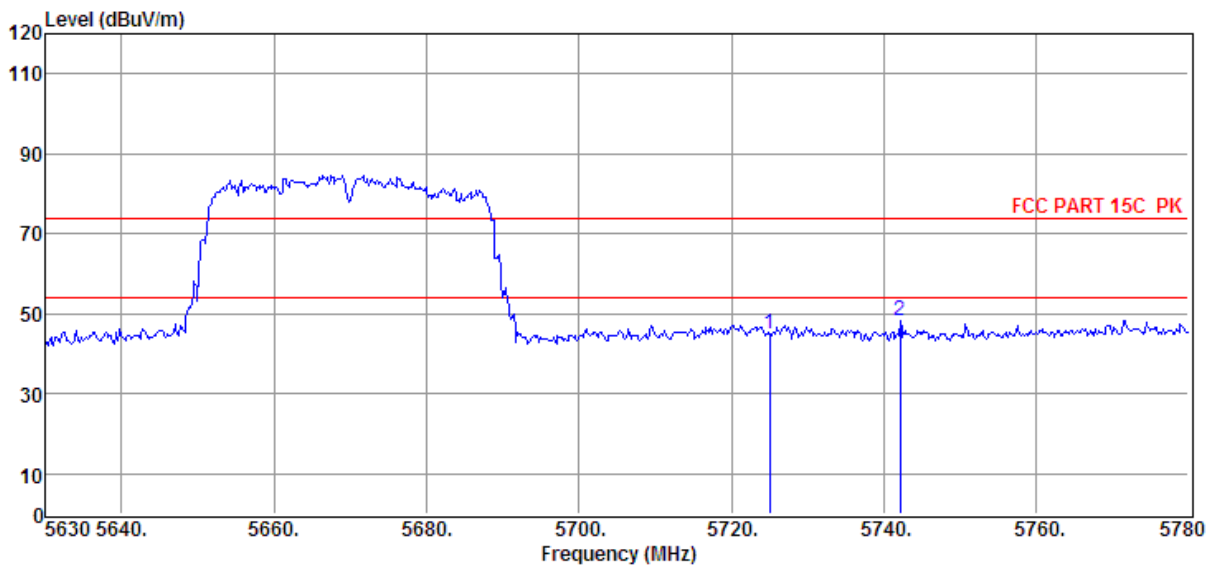

Item	Freq.	Read Level	Antenna Factor	PRM Factor	Cable Loss	Result Level	Limit Line	Over Limit	Detector	Polarization
(Mark)	(MHz)	(dBμV)	(dB/m)	dB	dB	(dBμV/m)	(dBμV/m)	(dB)		
1	5725.00	30.45	35.69	29.22	8.04	44.96	74.00	-29.04	Peak	HORIZONTAL
2	5742.20	33.55	35.70	29.21	8.05	48.09	74.00	-25.91	Peak	HORIZONTAL

Note: 1. Result Level = Read Level + Antenna Factor + Cable loss - PRM Factor.  
 2. If Peak Result complies with AV limit, AV Result is deemed to comply with AV limit.  
 3. Test setup: RBW: 1 MHz, VBW: 3 MHz, Sweep time: auto.

# TR-4-E-009 Radiated Emission Test Result

<b>Test Site</b>	: DDT 3m Chamber 1#	D:\2017 RE1# Report Data\Q17112903-1E\Q17112904-1E FCC 1G-18G 5G WIFI .EM6
<b>Test Date</b>	: 2018-01-09	<b>Tested By</b> : Sunny
<b>EUT</b>	: Wireless speaker	<b>Model Number</b> : ALLURE PORTABLE
<b>Power Supply</b>	: AC 120V/60Hz	<b>Test Mode</b> : TX mode
<b>Condition</b>	: Temp:24.5'C,Humi:55%, Press:100.1kPa	<b>Antenna/Distance</b> : 2016 HF907/3m/VERTICAL
<b>Memo</b>	: 11ac40 5755MHz	

Data: 253

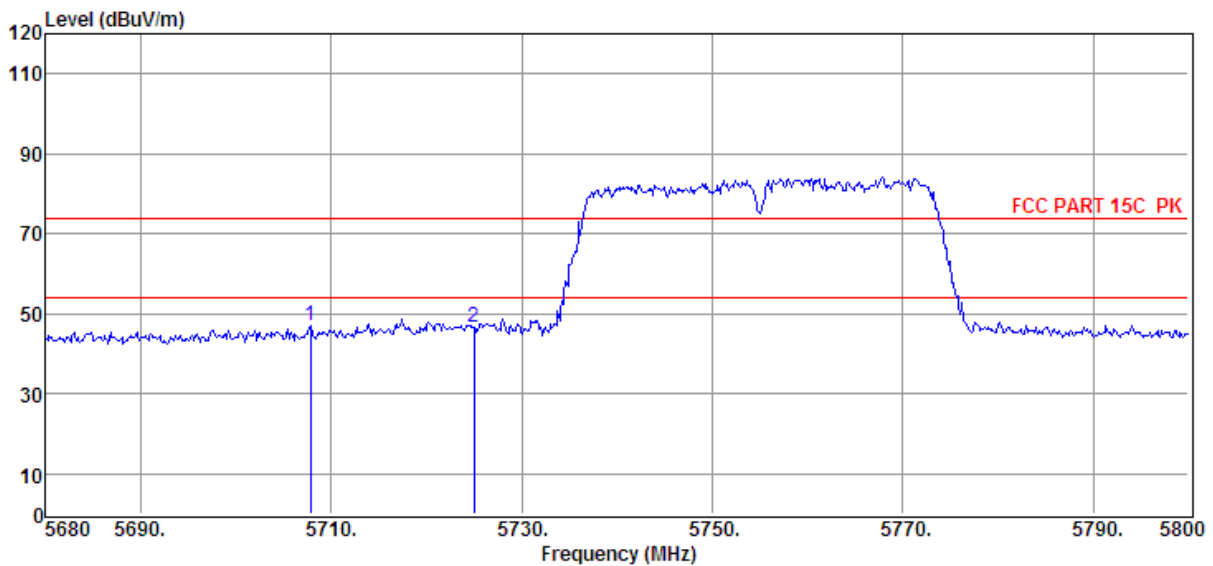

Item	Freq.	Read Level	Antenna Factor	PRM Factor	Cable Loss	Result Level	Limit Line	Over Limit	Detector	Polarization
(Mark)	(MHz)	(dBμV)	(dB/m)	dB	dB	(dBμV/m)	(dBμV/m)	(dB)		
1	5707.84	32.66	35.68	29.22	8.03	47.15	74.00	-26.85	Peak	VERTICAL
2	5725.00	32.25	35.69	29.22	8.04	46.76	74.00	-27.24	Peak	VERTICAL

- Note: 1. Result Level = Read Level + Antenna Factor + Cable loss - PRM Factor.  
 2. If Peak Result complies with AV limit, AV Result is deemed to comply with AV limit.  
 3. Test setup: RBW: 1 MHz, VBW: 3 MHz, Sweep time: auto.

# TR-4-E-009 Radiated Emission Test Result

<b>Test Site</b>	: DDT 3m Chamber 1#	D:\2017 RE1# Report Data\Q17112903-1E\Q17112904-1E FCC 1G-18G 5G WIFI .EM6
<b>Test Date</b>	: 2018-01-09	<b>Tested By</b> : Sunny
<b>EUT</b>	: Wireless speaker	<b>Model Number</b> : ALLURE PORTABLE
<b>Power Supply</b>	: AC 120V/60Hz	<b>Test Mode</b> : TX mode
<b>Condition</b>	: Temp:24.5'C,Humi:55%, Press:100.1kPa	<b>Antenna/Distance</b> : 2016 HF907/3m/HORIZONTAL
<b>Memo</b>	: 11ac40 5755MHz	

Data: 254

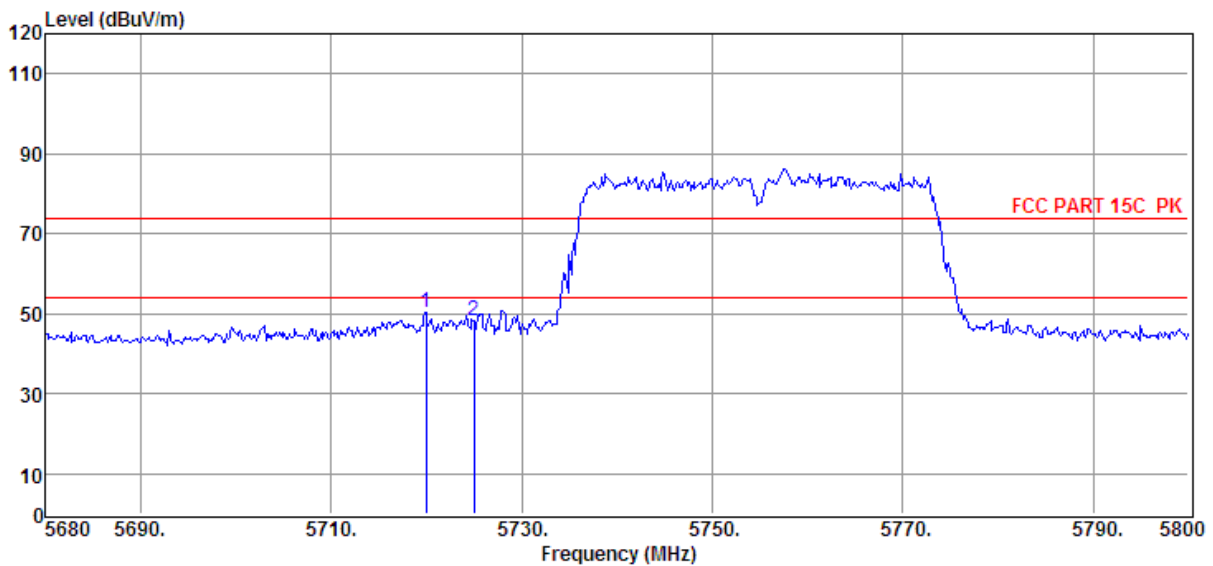

Item	Freq.	Read Level	Antenna Factor	PRM Factor	Cable Loss	Result Level	Limit Line	Over Limit	Detector	Polarization
(Mark)	(MHz)	(dBμV)	(dB/m)	dB	dB	(dBμV/m)	(dBμV/m)	(dB)		
1	5719.96	35.85	35.69	29.22	8.03	50.35	74.00	-23.65	Peak	HORIZONTAL
2	5725.00	33.65	35.69	29.22	8.04	48.16	74.00	-25.84	Peak	HORIZONTAL

Note: 1. Result Level = Read Level + Antenna Factor + Cable loss - PRM Factor.  
 2. If Peak Result complies with AV limit, AV Result is deemed to comply with AV limit.  
 3. Test setup: RBW: 1 MHz, VBW: 3 MHz, Sweep time: auto.

# TR-4-E-009 Radiated Emission Test Result

<b>Test Site</b>	: DDT 3m Chamber 1#	D:\2017 RE1# Report Data\Q17112903-1E\Q17112904-1E
		FCC 1G-18G 5G WIFI .EM6
<b>Test Date</b>	: 2018-01-09	<b>Tested By</b> : Sunny
<b>EUT</b>	: Wireless speaker	<b>Model Number</b> : ALLURE PORTABLE
<b>Power Supply</b>	: AC 120V/60Hz	<b>Test Mode</b> : TX mode
<b>Condition</b>	: Temp:24.5'C,Humi:55%, Press:100.1kPa	<b>Antenna/Distance</b> : 2016 HF907/3m/HORIZONTAL
<b>Memo</b>	: 11ac40 5795MHz	

Data: 255

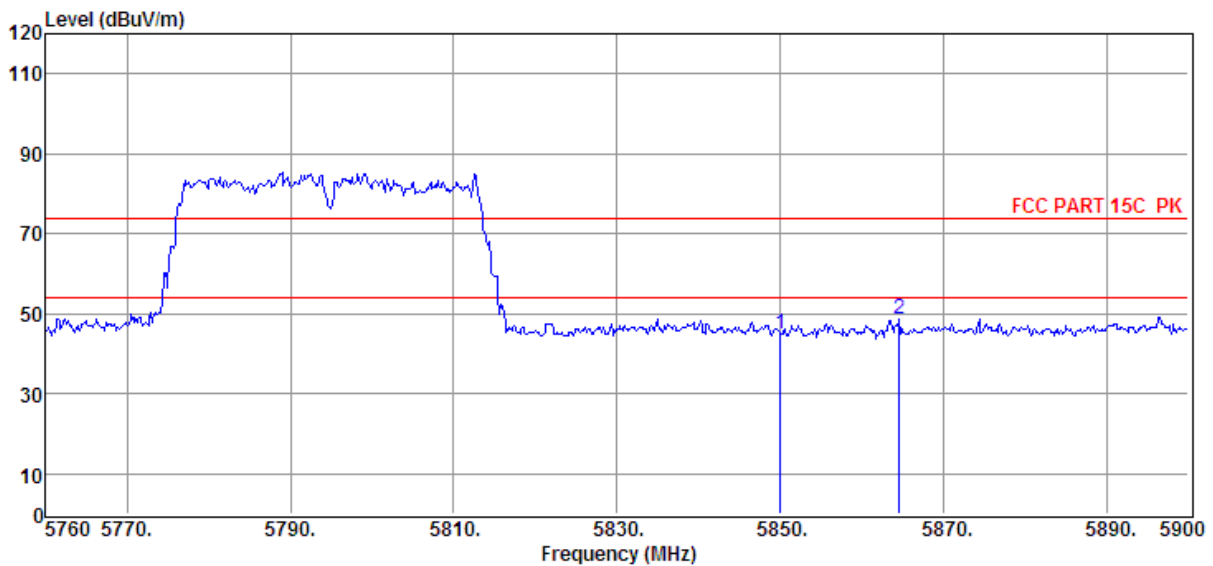

Item	Freq.	Read Level	Antenna Factor	PRM Factor	Cable Loss	Result Level	Limit Line	Over Limit	Detector	Polarization
(Mark)	(MHz)	(dBμV)	(dB/m)	dB	dB	(dBμV/m)	(dBμV/m)	(dB)		
1	5850.00	30.22	35.74	29.20	8.12	44.88	74.00	-29.12	Peak	HORIZONTAL
2	5864.58	33.87	35.75	29.20	8.12	48.54	74.00	-25.46	Peak	HORIZONTAL

Note: 1. Result Level = Read Level + Antenna Factor + Cable loss - PRM Factor.  
 2. If Peak Result complies with AV limit, AV Result is deemed to comply with AV limit.  
 3. Test setup: RBW: 1 MHz, VBW: 3 MHz, Sweep time: auto.

# TR-4-E-009 Radiated Emission Test Result

<b>Test Site</b>	: DDT 3m Chamber 1#	D:\2017 RE1# Report Data\Q17112903-1E\Q17112904-1E FCC 1G-18G 5G WIFI .EM6
<b>Test Date</b>	: 2018-01-09	<b>Tested By</b> : Sunny
<b>EUT</b>	: Wireless speaker	<b>Model Number</b> : ALLURE PORTABLE
<b>Power Supply</b>	: AC 120V/60Hz	<b>Test Mode</b> : TX mode
<b>Condition</b>	: Temp:24.5'C,Humi:55%, Press:100.1kPa	<b>Antenna/Distance</b> : 2016 HF907/3m/VERTICAL
<b>Memo</b>	: 11ac40 5795MHz	

Data: 256

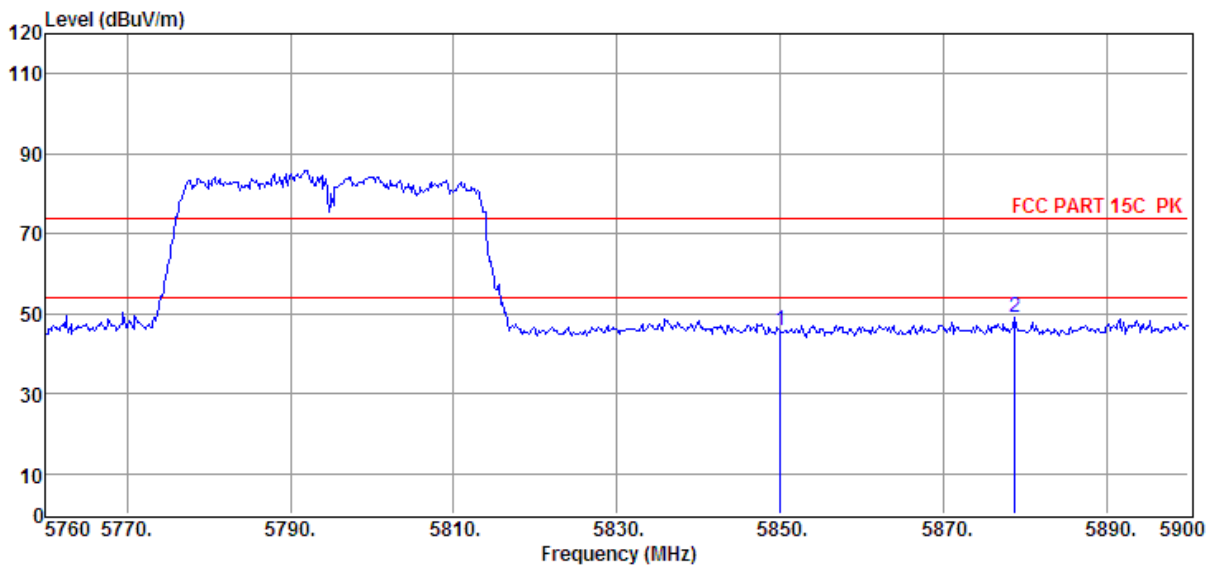

Item	Freq.	Read Level	Antenna Factor	PRM Factor	Cable Loss	Result Level	Limit Line	Over Limit	Detector	Polarization
(Mark)	(MHz)	(dBμV)	(dB/m)	dB	dB	(dBμV/m)	(dBμV/m)	(dB)		
1	5850.00	31.06	35.74	29.20	8.12	45.72	74.00	-28.28	Peak	VERTICAL
2	5878.72	34.42	35.75	29.20	8.13	49.10	74.00	-24.90	Peak	VERTICAL

Note: 1. Result Level = Read Level + Antenna Factor + Cable loss - PRM Factor.  
 2. If Peak Result complies with AV limit, AV Result is deemed to comply with AV limit.  
 3. Test setup: RBW: 1 MHz, VBW: 3 MHz, Sweep time: auto.

# TR-4-E-009 Radiated Emission Test Result

<b>Test Site</b>	: DDT 3m Chamber 1#	D:\2017 RE1# Report Data\Q17112903-1E\Q17112904-1E FCC 1G-18G 5G WIFI .EM6
<b>Test Date</b>	: 2018-01-09	<b>Tested By</b> : Sunny
<b>EUT</b>	: Wireless speaker	<b>Model Number</b> : ALLURE PORTABLE
<b>Power Supply</b>	: AC 120V/60Hz	<b>Test Mode</b> : TX mode
<b>Condition</b>	: Temp:24.5'C,Humi:55%, Press:100.1kPa	<b>Antenna/Distance</b> : 2016 HF907/3m/VERTICAL
<b>Memo</b>	: 11ac80 5210MHz	

Data: 257

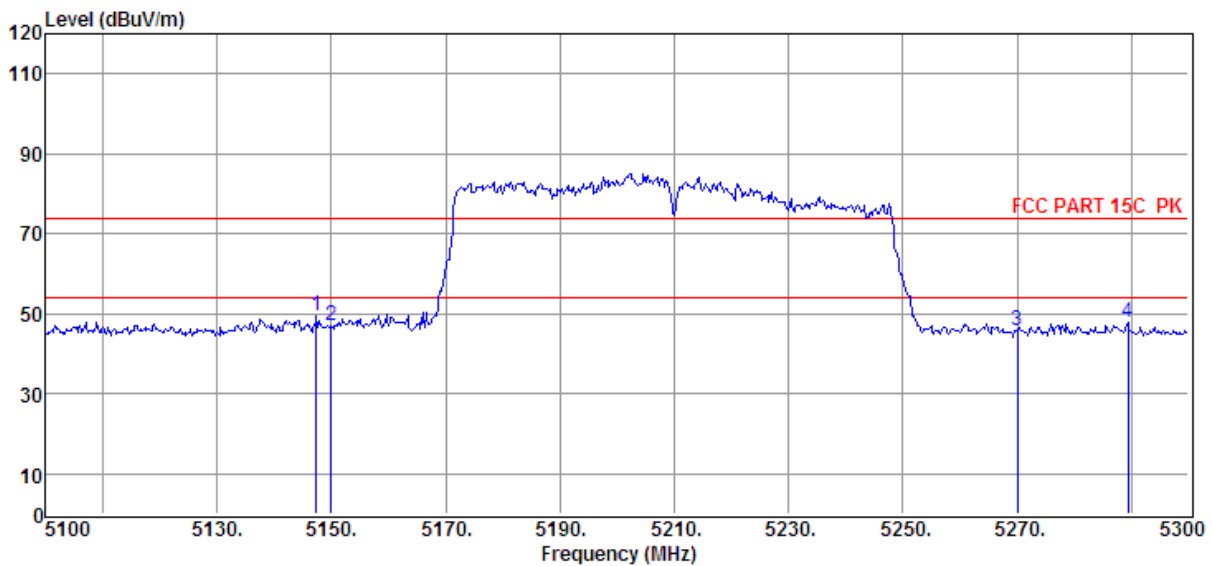

Item (Mark)	Freq. (MHz)	Read Level (dBμV)	Antenna Factor (dB/m)	PRM Facto r dB	Cable Loss dB	Result Level (dBμV/m)	Limit Line (dBμV/m)	Over Limit (dB)	Detector	Polarization
1	5147.40	36.02	35.18	29.33	7.67	49.54	74.00	-24.46	Peak	VERTICAL
2	5150.00	33.57	35.18	29.33	7.67	47.09	74.00	-26.91	Peak	VERTICAL
3	5270.00	32.13	35.32	29.32	7.75	45.88	74.00	-28.12	Peak	VERTICAL
4	5289.40	34.03	35.35	29.31	7.76	47.83	74.00	-26.17	Peak	VERTICAL

- Note: 1. Result Level = Read Level + Antenna Factor + Cable loss - PRM Factor.  
 2. If Peak Result complies with AV limit, AV Result is deemed to comply with AV limit.  
 3. Test setup: RBW: 1 MHz, VBW: 3 MHz, Sweep time: auto.

# TR-4-E-009 Radiated Emission Test Result

<b>Test Site</b>	: DDT 3m Chamber 1#	D:\2017 RE1# Report Data\Q17112903-1E\Q17112904-1E
		FCC 1G-18G 5G WIFI .EM6
<b>Test Date</b>	: 2018-01-09	<b>Tested By</b> : Sunny
<b>EUT</b>	: Wireless speaker	<b>Model Number</b> : ALLURE PORTABLE
<b>Power Supply</b>	: AC 120V/60Hz	<b>Test Mode</b> : TX mode
<b>Condition</b>	: Temp:24.5'C,Humi:55%, Press:100.1kPa	<b>Antenna/Distance</b> : 2016 HF907/3m/HORIZONTAL
<b>Memo</b>	: 11ac80 5210MHz	

Data: 258

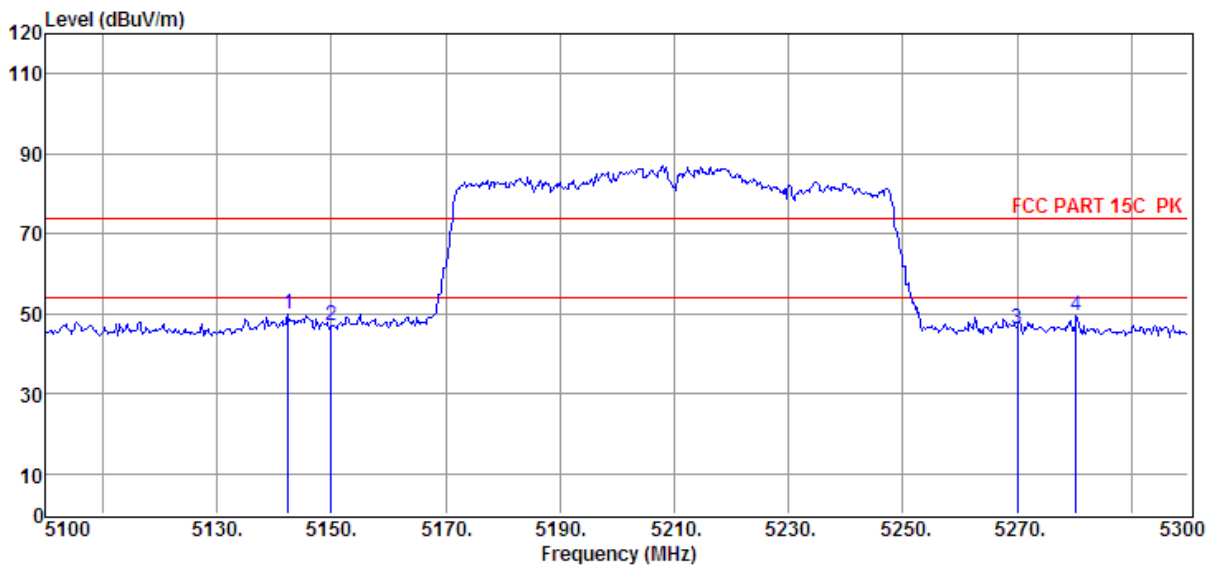

Item (Mark)	Freq. (MHz)	Read Level (dBμV)	Antenna Factor (dB/m)	PRM Factor (dB)	Cable Loss (dB)	Result Level (dBμV/m)	Limit Line (dBμV/m)	Over Limit (dB)	Detector	Polarization
1	5142.40	36.33	35.17	29.33	7.67	49.84	74.00	-24.16	Peak	HORIZONTAL
2	5150.00	33.46	35.18	29.33	7.67	46.98	74.00	-27.02	Peak	HORIZONTAL
3	5270.00	32.52	35.32	29.32	7.75	46.27	74.00	-27.73	Peak	HORIZONTAL
4	5280.40	35.86	35.34	29.31	7.76	49.65	74.00	-24.35	Peak	HORIZONTAL

- Note: 1. Result Level = Read Level + Antenna Factor + Cable loss - PRM Factor.  
 2. If Peak Result complies with AV limit, AV Result is deemed to comply with AV limit.  
 3. Test setup: RBW: 1 MHz, VBW: 3 MHz, Sweep time: auto.

# TR-4-E-009 Radiated Emission Test Result

<b>Test Site</b>	: DDT 3m Chamber 1#	D:\2017 RE1# Report Data\Q17112903-1E\Q17112904-1E FCC 1G-18G 5G WIFI .EM6
<b>Test Date</b>	: 2018-01-09	<b>Tested By</b> : Sunny
<b>EUT</b>	: Wireless speaker	<b>Model Number</b> : ALLURE PORTABLE
<b>Power Supply</b>	: AC 120V/60Hz	<b>Test Mode</b> : TX mode
<b>Condition</b>	: Temp:24.5'C,Humi:55%, Press:100.1kPa	<b>Antenna/Distance</b> : 2016 HF907/3m/HORIZONTAL
<b>Memo</b>	: 11ac80 5290MHz	

Data: 259

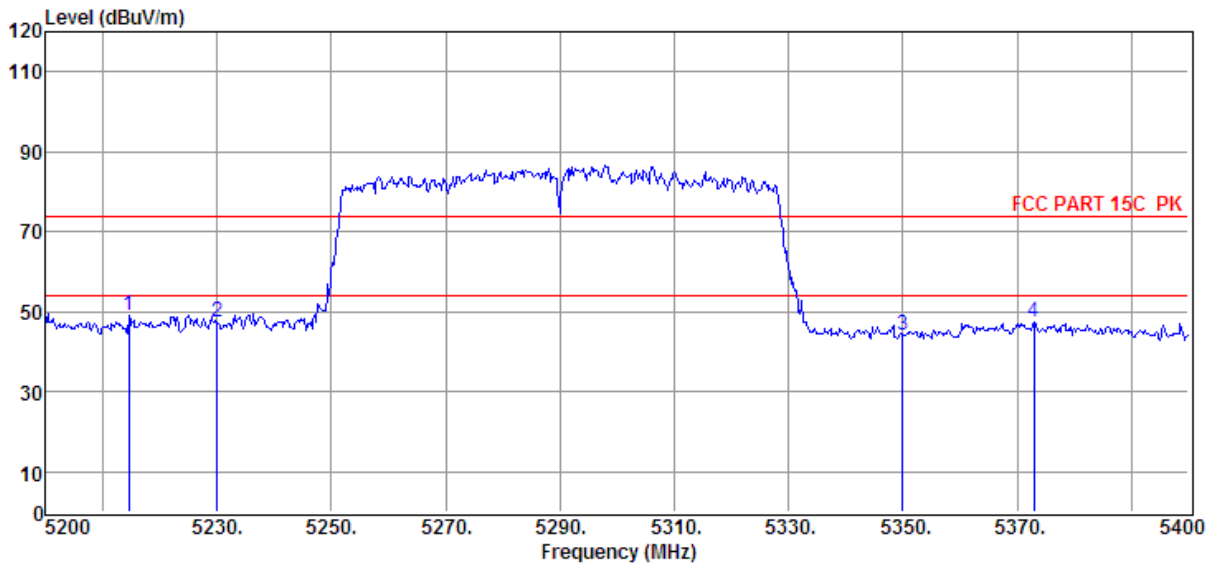

Item (Mark)	Freq. (MHz)	Read Level (dBμV)	Antenna Factor (dB/m)	PRM Facto r dB	Cable Loss dB	Result Level (dBμV/m)	Limit Line (dBμV/m)	Over Limit (dB)	Detector	Polarization
1	5214.60	35.31	35.26	29.33	7.72	48.96	74.00	-25.04	Peak	HORIZONTAL
2	5230.00	33.63	35.28	29.32	7.72	47.31	74.00	-26.69	Peak	HORIZONTAL
3	5350.00	30.30	35.42	29.30	7.80	44.22	74.00	-29.78	Peak	HORIZONTAL
4	5373.00	33.34	35.45	29.30	7.81	47.30	74.00	-26.70	Peak	HORIZONTAL

Note: 1. Result Level = Read Level + Antenna Factor + Cable loss - PRM Factor.  
 2. If Peak Result complies with AV limit, AV Result is deemed to comply with AV limit.  
 3. Test setup: RBW: 1 MHz, VBW: 3 MHz, Sweep time: auto.

# TR-4-E-009 Radiated Emission Test Result

<b>Test Site</b>	: DDT 3m Chamber 1#	D:\2017 RE1# Report Data\Q17112903-1E\Q17112904-1E FCC 1G-18G 5G WIFI .EM6
<b>Test Date</b>	: 2018-01-09	<b>Tested By</b> : Sunny
<b>EUT</b>	: Wireless speaker	<b>Model Number</b> : ALLURE PORTABLE
<b>Power Supply</b>	: AC 120V/60Hz	<b>Test Mode</b> : TX mode
<b>Condition</b>	: Temp:24.5'C,Humi:55%, Press:100.1kPa	<b>Antenna/Distance</b> : 2016 HF907/3m/VERTICAL
<b>Memo</b>	: 11ac80 5290MHz	

Data: 260

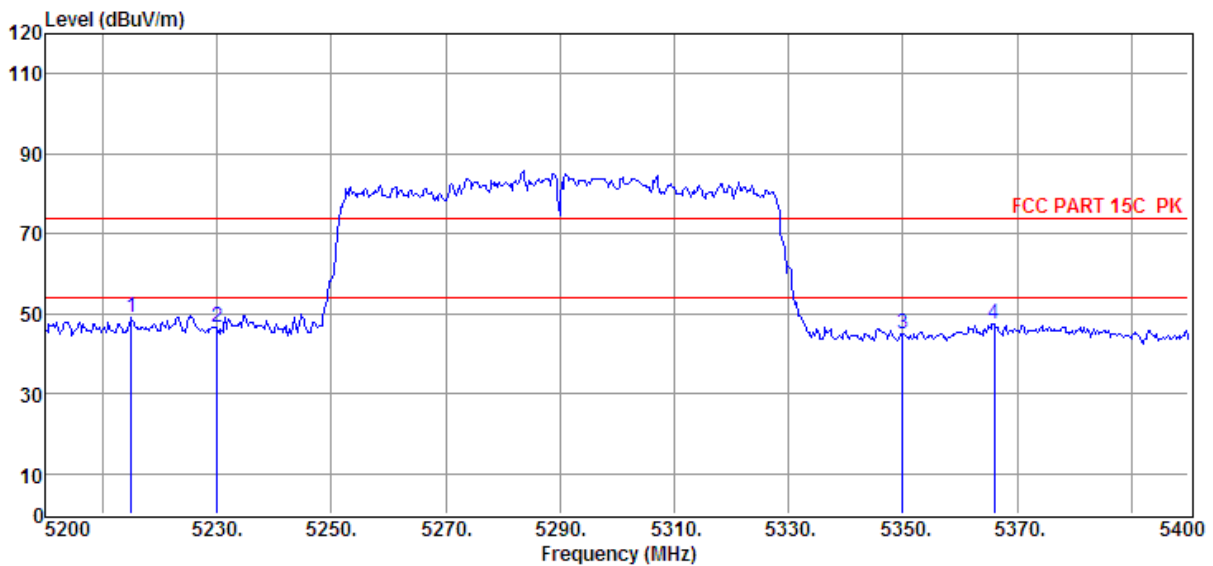

Item (Mark)	Freq. (MHz)	Read Level (dBμV)	Antenna Factor (dB/m)	PRM Facto r dB	Cable Loss dB	Result Level (dBμV/m)	Limit Line (dBμV/m)	Over Limit (dB)	Detector	Polarization
1	5215.00	35.31	35.26	29.33	7.72	48.96	74.00	-25.04	Peak	VERTICAL
2	5230.00	32.78	35.28	29.32	7.72	46.46	74.00	-27.54	Peak	VERTICAL
3	5350.00	31.11	35.42	29.30	7.80	45.03	74.00	-28.97	Peak	VERTICAL
4	5366.00	33.30	35.44	29.30	7.81	47.25	74.00	-26.75	Peak	VERTICAL

- Note: 1. Result Level = Read Level + Antenna Factor + Cable loss - PRM Factor.  
 2. If Peak Result complies with AV limit, AV Result is deemed to comply with AV limit.  
 3. Test setup: RBW: 1 MHz, VBW: 3 MHz, Sweep time: auto.

# TR-4-E-009 Radiated Emission Test Result

<b>Test Site</b>	: DDT 3m Chamber 1#	D:\2017 RE1# Report Data\Q17112903-1E\Q17112904-1E
		FCC 1G-18G 5G WIFI .EM6
<b>Test Date</b>	: 2018-01-09	<b>Tested By</b> : Sunny
<b>EUT</b>	: Wireless speaker	<b>Model Number</b> : ALLURE PORTABLE
<b>Power Supply</b>	: AC 120V/60Hz	<b>Test Mode</b> : TX mode
<b>Condition</b>	: Temp:24.5'C,Humi:55%, Press:100.1kPa	<b>Antenna/Distance</b> : 2016 HF907/3m/VERTICAL
<b>Memo</b>	: 11ac80 5530MHz	

Data: 261

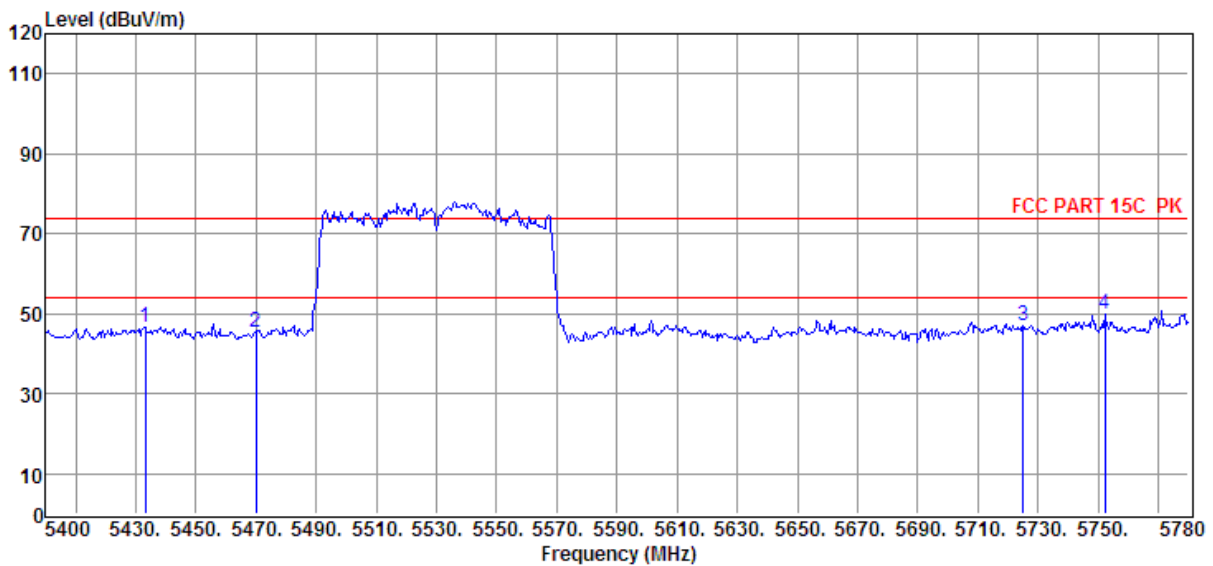

Item (Mark)	Freq. (MHz)	Read Level (dBμV)	Antenna Factor (dB/m)	PRM Facto r dB	Cable Loss dB	Result Level (dBμV/m)	Limit Line (dBμV/m)	Over Limit (dB)	Detector	Polarization
1	5433.06	32.60	35.52	29.28	7.85	46.69	74.00	-27.31	Peak	VERTICAL
2	5470.00	31.38	35.56	29.27	7.88	45.55	74.00	-28.45	Peak	VERTICAL
3	5725.00	32.65	35.69	29.22	8.04	47.16	74.00	-26.84	Peak	VERTICAL
4	5752.26	35.36	35.70	29.21	8.05	49.90	74.00	-24.10	Peak	VERTICAL

- Note: 1. Result Level = Read Level + Antenna Factor + Cable loss - PRM Factor.  
 2. If Peak Result complies with AV limit, AV Result is deemed to comply with AV limit.  
 3. Test setup: RBW: 1 MHz, VBW: 3 MHz, Sweep time: auto.

# TR-4-E-009 Radiated Emission Test Result

<b>Test Site</b>	: DDT 3m Chamber 1#	D:\2017 RE1# Report Data\Q17112903-1E\Q17112904-1E
		FCC 1G-18G 5G WIFI .EM6
<b>Test Date</b>	: 2018-01-09	<b>Tested By</b> : Sunny
<b>EUT</b>	: Wireless speaker	<b>Model Number</b> : ALLURE PORTABLE
<b>Power Supply</b>	: AC 120V/60Hz	<b>Test Mode</b> : TX mode
<b>Condition</b>	: Temp:24.5'C,Humi:55%, Press:100.1kPa	<b>Antenna/Distance</b> : 2016 HF907/3m/HORIZONTAL
<b>Memo</b>	: 11ac80 5530MHz	

Data: 262

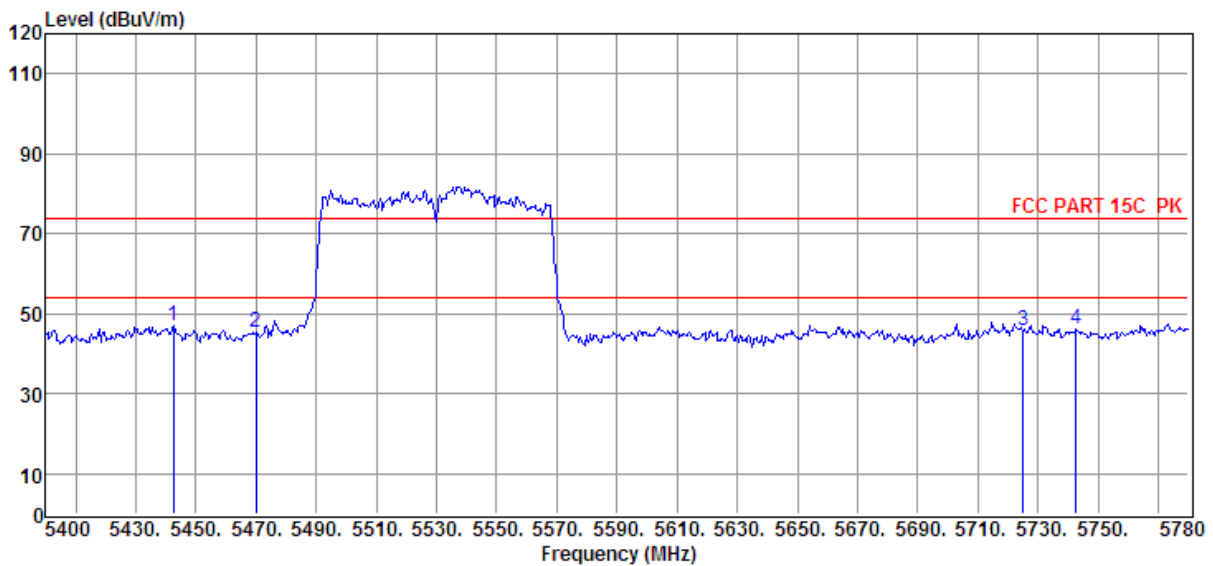

Item (Mark)	Freq. (MHz)	Read Level (dBμV)	Antenna Factor (dB/m)	PRM Facto r dB	Cable Loss dB	Result Level (dBμV/m)	Limit Line (dBμV/m)	Over Limit (dB)	Detector	Polarization
1	5442.56	33.08	35.53	29.28	7.86	47.19	74.00	-26.81	Peak	HORIZONTAL
2	5470.00	31.01	35.56	29.27	7.88	45.18	74.00	-28.82	Peak	HORIZONTAL
3	5725.00	31.12	35.69	29.22	8.04	45.63	74.00	-28.37	Peak	HORIZONTAL
4	5742.76	31.62	35.70	29.21	8.05	46.16	74.00	-27.84	Peak	HORIZONTAL

- Note: 1. Result Level = Read Level + Antenna Factor + Cable loss - PRM Factor.  
 2. If Peak Result complies with AV limit, AV Result is deemed to comply with AV limit.  
 3. Test setup: RBW: 1 MHz, VBW: 3 MHz, Sweep time: auto.

# TR-4-E-009 Radiated Emission Test Result

**Test Site** : DDT 3m Chamber 1# D:\2017 RE1# Report Data\Q17112903-1E\Q17112904-1E  
FCC 1G-18G 5G WIFI .EM6  
**Test Date** : 2018-01-09 **Tested By** : Sunny  
**EUT** : Wireless speaker **Model Number** : ALLURE PORTABLE  
**Power Supply** : AC 120V/60Hz **Test Mode** : TX mode  
**Condition** : Temp:24.5'C,Humi:55%,  
Press:100.1kPa **Antenna/Distance** : 2016 HF907/3m/HORIZONTAL  
**Memo** : 11ac80 5775MHz

Data: 263

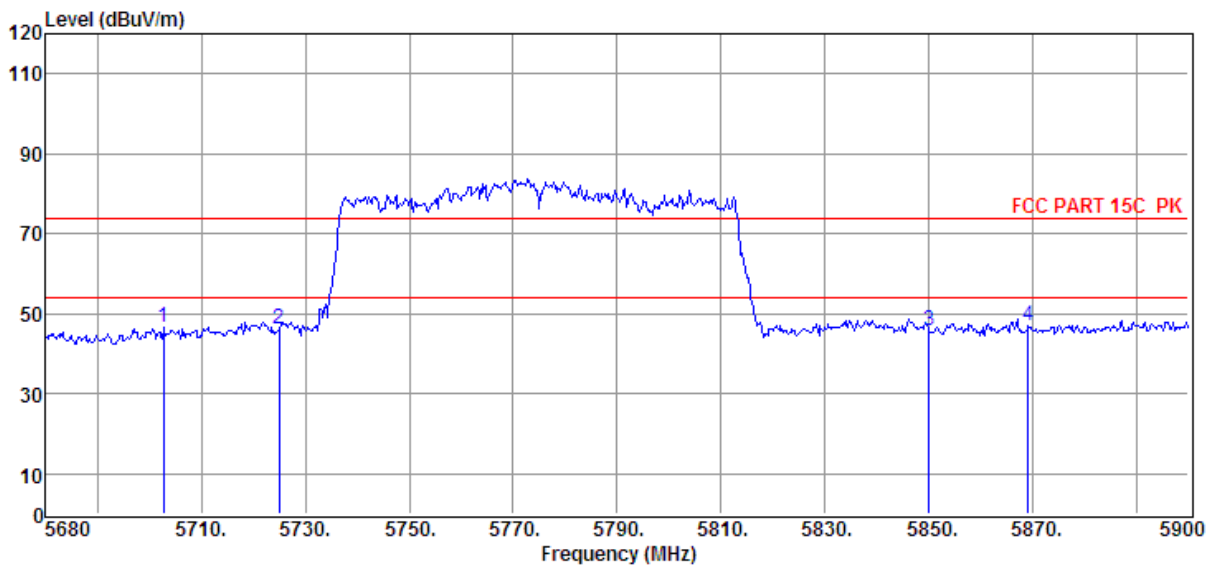

Item (Mark)	Freq. (MHz)	Read Level (dBμV)	Antenna Factor (dB/m)	PRM Facto r dB	Cable Loss dB	Result Level (dBμV/m)	Limit Line (dBμV/m)	Over Limit (dB)	Detector	Polarization
1	5702.66	32.14	35.68	29.22	8.02	46.62	74.00	-27.38	Peak	HORIZONTAL
2	5725.00	31.88	35.69	29.22	8.04	46.39	74.00	-27.61	Peak	HORIZONTAL
3	5850.00	31.12	35.74	29.20	8.12	45.78	74.00	-28.22	Peak	HORIZONTAL
4	5869.20	32.31	35.75	29.20	8.13	46.99	74.00	-27.01	Peak	HORIZONTAL

- Note: 1. Result Level = Read Level + Antenna Factor + Cable loss - PRM Factor.  
 2. If Peak Result complies with AV limit, AV Result is deemed to comply with AV limit.  
 3. Test setup: RBW: 1 MHz, VBW: 3 MHz, Sweep time: auto.

# TR-4-E-009 Radiated Emission Test Result

**Test Site** : DDT 3m Chamber 1# D:\2017 RE1# Report Data\Q17112903-1E\Q17112904-1E FCC 1G-18G 5G WIFI .EM6  
**Test Date** : 2018-01-09 **Tested By** : Sunny  
**EUT** : Wireless speaker **Model Number** : ALLURE PORTABLE  
**Power Supply** : AC 120V/60Hz **Test Mode** : TX mode  
**Condition** : Temp:24.5'C,Humi:55%,  
 Press:100.1kPa **Antenna/Distance** : 2016 HF907/3m/VERTICAL  
**Memo** : 11ac80 5775MHz

Data: 264

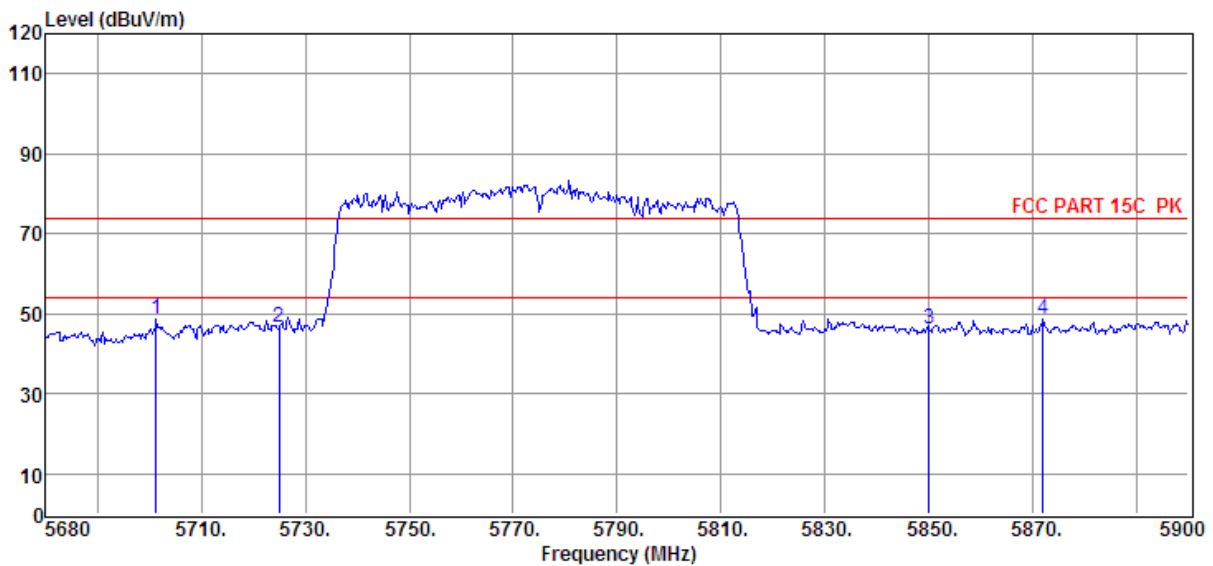

Item (Mark)	Freq. (MHz)	Read Level (dBμV)	Antenna Factor (dB/m)	PRM Facto r dB	Cable Loss dB	Result Level (dBμV/m)	Limit Line (dBμV/m)	Over Limit (dB)	Detecto r	Polarization
1	5701.34	34.08	35.68	29.22	8.02	48.56	74.00	-25.44	Peak	VERTICAL
2	5725.00	32.15	35.69	29.22	8.04	46.66	74.00	-27.34	Peak	VERTICAL
3	5850.00	31.41	35.74	29.20	8.12	46.07	74.00	-27.93	Peak	VERTICAL
4	5872.06	33.82	35.75	29.20	8.13	48.50	74.00	-25.50	Peak	VERTICAL

- Note: 1. Result Level = Read Level + Antenna Factor + Cable loss - PRM Factor.  
 2. If Peak Result complies with AV limit, AV Result is deemed to comply with AV limit.  
 3. Test setup: RBW: 1 MHz, VBW: 3 MHz, Sweep time: auto.

## 11. Power Line Conducted Emission

### 11.1. Block diagram of test setup

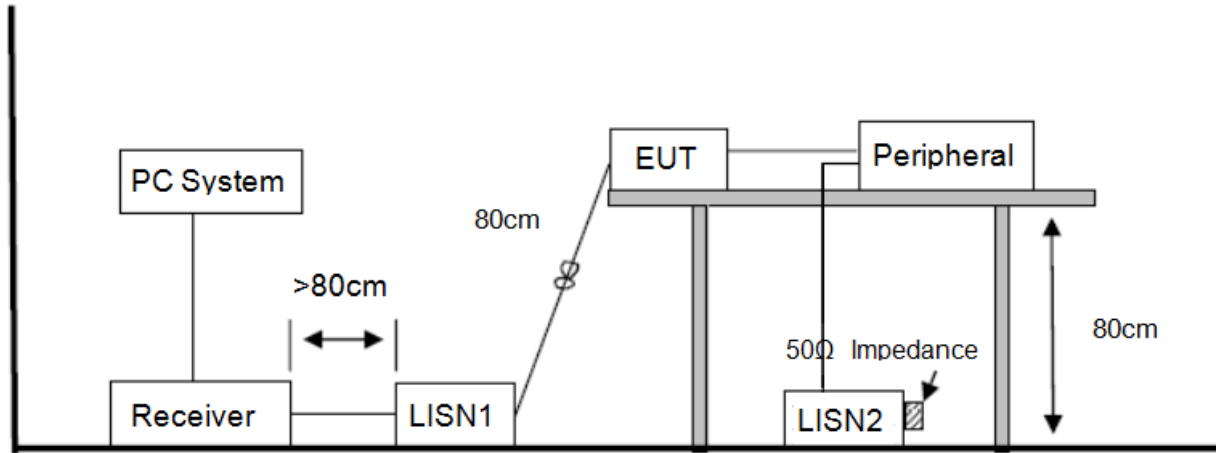

### 11.2. Power Line Conducted Emission Limits(Class B)

Frequency	Quasi-Peak Level dB( $\mu$ V)	Average Level dB( $\mu$ V)
150kHz ~ 500kHz	66 ~ 56*	56 ~ 46*
500kHz ~ 5MHz	56	46
5MHz ~ 30MHz	60	50

Note 1: \* Decreasing linearly with logarithm of frequency.

Note 2: The lower limit shall apply at the transition frequencies.

### 11.3. Test Procedure

The EUT and Support equipment, if needed, were put placed on a non-metallic table, 80cm above the ground plane.

Configuration EUT to simulate typical usage as described in clause 2.3 and test equipment as described in clause 10.2 of this report.

All I/O cables were positioned to simulate typical actual usage as per ANSI C63.4.

All support equipment power received from a second LISN.

Emissions were measured on each current carrying line of the EUT using an EMI Test Receiver connected to the LISN powering the EUT.

The Receiver scanned from 150 kHz to 30MHz for emissions in each of the test modes.

During the above scans, the emissions were maximized by cable manipulation.

The test mode(s) described in clause 2.3 were scanned during the preliminary test.

After the preliminary scan, we found the test mode producing the highest emission level.

The EUT configuration and worse cable configuration of the above highest emission levels were

recorded for reference of the final test.

EUT and support equipment were set up on the test bench as per the configuration with highest emission level in the preliminary test.

A scan was taken on both power lines, Neutral and Line, recording at least the six highest emissions.

Emission frequency and amplitude were recorded into a computer in which correction factors were used to calculate the emission level and compare reading to the applicable limit.

The test data of the worst-case condition(s) was recorded.

The bandwidth of test receiver is set at 9 KHz.

#### **11.4. Test Result**

##### **PASS. (See below detailed test result)**

Note1: All emissions not reported below are too low against the prescribed limits.

Note2: “-----” means peak detection; “-----” means average detection

Note3: Pre-test AC conducted emission at both voltage AC 120V/60Hz and AC 240V/50Hz, recorded worst case (AC 120V/60Hz).

# TR-4-E-010 Conducted Emission Test Result

**Test Site** : DDT 1# Shield Room E:\2017 CE report data\Q17112903-1E\CE.EM6  
**Test Date** : 2017-12-22 **Tested By** : Sincere  
**EUT** : Wireless Speaker **Model Number** : ALLURE PORTABLE  
**Power Supply** : AC 120V/60Hz **Test Mode** : TX mode  
**Condition** : Temp:24.5°C,Humi:55%,  
 Press:100.1kPa **LISN** : 2017 ENV216/LINE  
**Memo** :

Data: 22

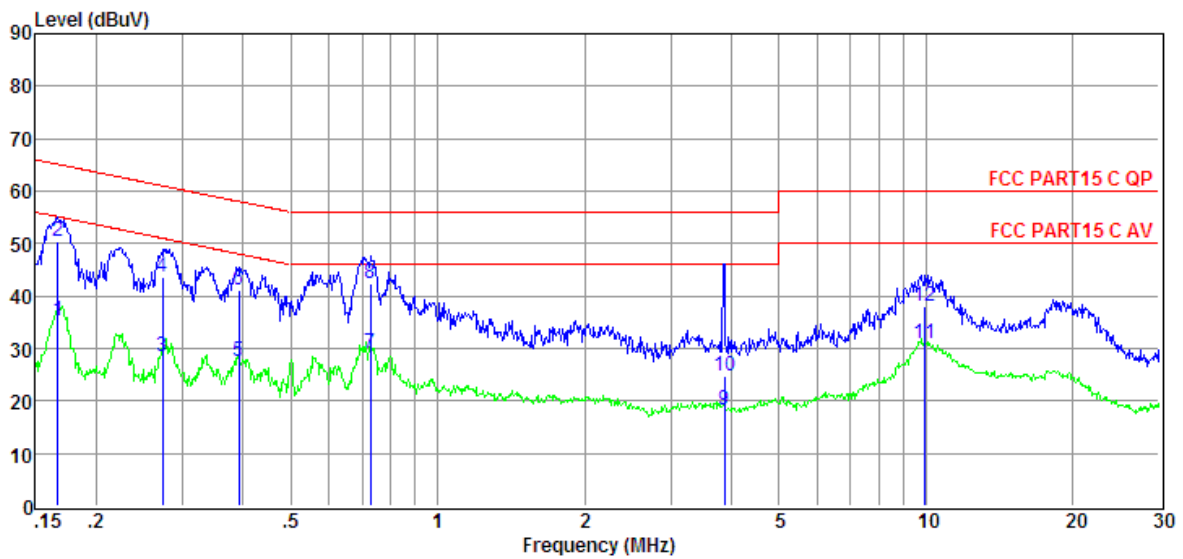

Item (Mark)	Freq. (MHz)	Read Level (dBμV)	LISN Factor (dB)	Cable Loss (dB)	Pulse Limiter Factor (dB)	Result Level (dBμV)	Limit Line (dBμV)	Over Limit (dB)	Detector	Phase
1	0.17	15.98	9.52	-0.04	9.86	35.32	55.12	-19.80	Average	LINE
2	0.17	31.08	9.52	-0.04	9.86	50.42	65.12	-14.70	QP	LINE
3	0.27	9.02	9.52	-0.04	9.86	28.36	51.03	-22.67	Average	LINE
4	0.27	24.24	9.52	-0.04	9.86	43.58	61.03	-17.45	QP	LINE
5	0.39	8.06	9.53	-0.04	9.83	27.38	48.03	-20.65	Average	LINE
6	0.39	21.67	9.53	-0.04	9.83	40.99	58.03	-17.04	QP	LINE
7	0.73	9.65	9.55	-0.09	9.86	28.97	46.00	-17.03	Average	LINE
8	0.73	23.01	9.55	-0.09	9.86	42.33	56.00	-13.67	QP	LINE
9	3.86	-0.99	9.63	-0.11	9.87	18.40	46.00	-27.60	Average	LINE
10	3.86	5.41	9.63	-0.11	9.87	24.80	56.00	-31.20	QP	LINE
11	9.97	11.34	9.82	-0.12	9.89	30.93	50.00	-19.07	Average	LINE
12	9.97	18.50	9.82	-0.12	9.89	38.09	60.00	-21.91	QP	LINE

- Note: 1. Result Level = Read Level +LISN Factor + Pulse Limiter Factor + Cable loss.  
 2. If QP Result complies with AV limit, AV Result is deemed to comply with AV limit.  
 3. Test setup: RBW: 200 Hz (9 kHz—150 kHz), 9 kHz (150 kHz—30 MHz).  
 4. Step size: 80Hz (0.009MHz-0.15MHz), 4 kHz (0.15MHz-30MHz), Scan time: auto.

# TR-4-E-010 Conducted Emission Test Result

**Test Site** : DDT 1# Shield Room E:\2017 CE report data\Q17112903-1E\CE.EM6  
**Test Date** : 2017-12-22 **Tested By** : Sincere  
**EUT** : Wireless Speaker **Model Number** : ALLURE PORTABLE  
**Power Supply** : AC 120V/60Hz **Test Mode** : TX mode  
**Condition** : Temp:24.5°C,Humi:55%,  
**LISN** : 2017 ENV216/NEUTRAL  
 Press:100.1kPa  
**Memo** :

Data: 24

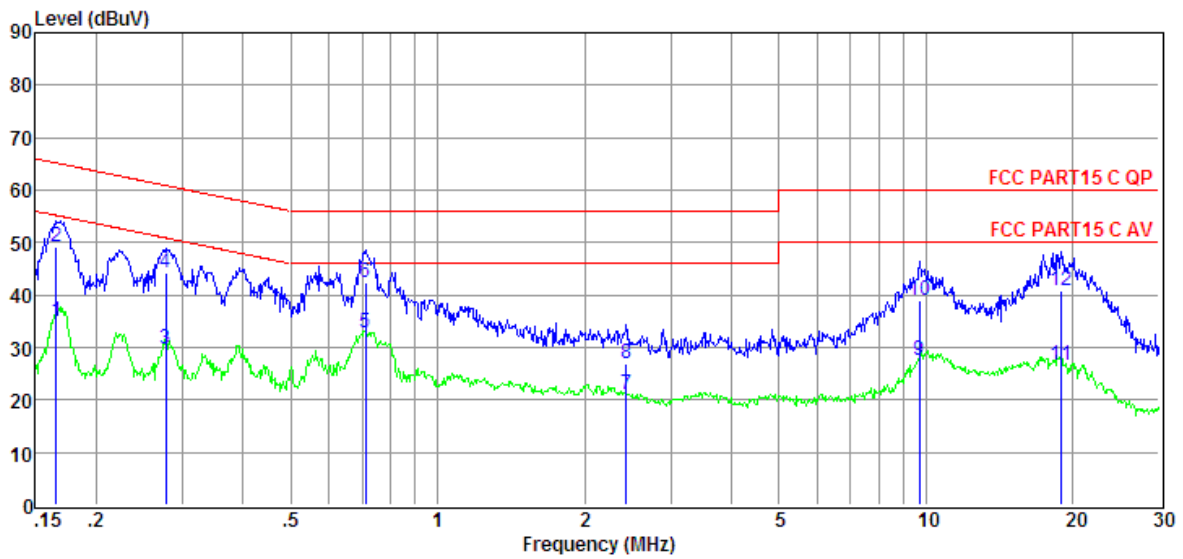

Item (Mark)	Freq. (MHz)	Read Level (dBμV)	LISN Factor (dB)	Cable Loss (dB)	Pulse Limiter Factor (dB)	Result Level (dBμV)	Limit Line (dBμV)	Over Limit (dB)	Detector	Phase
1	0.17	15.55	9.47	-0.04	9.86	34.84	55.16	-20.32	Average	NEUTRAL
2	0.17	29.87	9.47	-0.04	9.86	49.16	65.16	-16.00	QP	NEUTRAL
3	0.28	10.49	9.41	-0.04	9.86	29.72	50.90	-21.18	Average	NEUTRAL
4	0.28	25.08	9.41	-0.04	9.86	44.31	60.90	-16.59	QP	NEUTRAL
5	0.71	13.65	9.32	-0.09	9.86	32.74	46.00	-13.26	Average	NEUTRAL
6	0.71	23.39	9.32	-0.09	9.86	42.48	56.00	-13.52	QP	NEUTRAL
7	2.44	1.89	9.40	-0.12	9.87	21.04	46.00	-24.96	Average	NEUTRAL
8	2.44	7.91	9.40	-0.12	9.87	27.06	56.00	-28.94	QP	NEUTRAL
9	9.71	8.34	9.43	-0.12	9.89	27.54	50.00	-22.46	Average	NEUTRAL
10	9.71	19.62	9.43	-0.12	9.89	38.82	60.00	-21.18	QP	NEUTRAL
11	18.92	7.16	9.47	-0.11	9.94	26.46	50.00	-23.54	Average	NEUTRAL
12	18.92	21.44	9.47	-0.11	9.94	40.74	60.00	-19.26	QP	NEUTRAL

- Note: 1. Result Level = Read Level + LISN Factor + Pulse Limiter Factor + Cable loss.  
 2. If QP Result complies with AV limit, AV Result is deemed to comply with AV limit.  
 3. Test setup: RBW: 200 Hz (9 kHz—150 kHz), 9 kHz (150 kHz—30 MHz).  
 4. Step size: 80Hz (0.009MHz-0.15MHz), 4 kHz (0.15MHz-30MHz), Scan time: auto.

## **12. Antenna Requirements**

### **12.1. Limit**

For intentional device, according to FCC 47 CFR Section 15.203, an intentional radiator shall be designed to ensure that no antenna other than that furnished by the responsible party shall be used with the device. And according to FCC 47 CFR Section 15.247 (b), if transmitting antennas of directional gain greater than 6dBi are used, the power shall be reduced by the amount in dB that the directional gain of the antenna exceeds 6dBi.

### **12.2. Result**

The antennas used for this product are integrated antenna and other than that furnished by the responsible party shall be used with the device, the maximum peak gain of the transmit antenna is only 4.36dBi.

## 13. Dynamic Frequency Selection

### 13.1. Applicability of DFS requirements

Table 1: Applicability of DFS Requirements Prior to Use of a Channel

Requirement	Operational Mode		
	<input type="checkbox"/> Master	<input checked="" type="checkbox"/> Client Without Radar Detection	<input type="checkbox"/> Client With Radar Detection
Non-Occupancy Period	Yes	Not required	Yes
DFS Detection Threshold	Yes	Not required	Yes
Channel Availability Check Time	Yes	Not required	Not required
U-NII Detection Bandwidth	Yes	Not required	Yes

Table 2: Applicability of DFS requirements during normal operation

Requirement	Operational Mode	
	<input type="checkbox"/> Master Device or Client with Radar Detection	<input checked="" type="checkbox"/> Client Without Radar Detection
DFS Detection Threshold	Yes	Not required
Channel Closing Transmission Time	Yes	Yes
Channel Move Time	Yes	Yes
U-NII Detection Bandwidth	Yes	Not required

Additional requirements for devices with multiple bandwidth modes	<input type="checkbox"/> Master Device or Client with Radar Detection	<input checked="" type="checkbox"/> Client Without Radar Detection
U-NII Detection Bandwidth and Statistical Performance Check	All BW modes must be tested	Not required
Channel Move Time and Channel Closing Transmission Time	Test using widest BW mode available	Test using the widest BW mode available for the link
All other tests	Any single BW mode	Not required

Note: Frequencies selected for statistical performance check should include several frequencies within the radar detection bandwidth and frequencies near the edge of the radar detection bandwidth. For 802.11 devices it is suggested to select frequencies in each of the bonded 20 MHz channels and the channel center frequency.

### 13.2. Limit

#### (1) DFS Detection Thresholds

Table 3: DFS Detection Thresholds for Master Devices and Client Devices With Radar Detection

Maximum Transmit Power	Value (See Notes 1, 2, and 3)
EIRP $\geq$ 200 milliwatt	-64 dBm
EIRP $<$ 200 milliwatt and power spectral density $<$ 10 dBm/MHz	-62 dBm
EIRP $<$ 200 milliwatt that do not meet the power spectral density requirement	-64 dBm

Note 1: This is the level at the input of the receiver assuming a 0 dBi receive antenna.  
 Note 2: Throughout these test procedures an additional 1 dB has been added to the amplitude of the test transmission waveforms to account for variations in measurement equipment. This will ensure that the test signal is at or above the detection threshold level to trigger a DFS response.  
 Note3: EIRP is based on the highest antenna gain. For MIMO devices refer to KDB Publication 662911 D01.

## (2) DFS Response Requirements

Table 4: DFS Response Requirement Values

Parameter	Value
Non-occupancy period	Minimum 30 minutes
Channel Availability Check Time	60 seconds
Channel Move Time	10 seconds See Note 1.
Channel Closing Transmission Time	200 milliseconds + an aggregate of 60 milliseconds over remaining 10 second period. See Notes 1 and 2.
U-NII Detection Bandwidth	Minimum 100% of the U-NII 99% transmission power bandwidth. See Note 3.

Note 1: Channel Move Time and the Channel Closing Transmission Time should be performed with Radar Type 0. The measurement timing begins at the end of the Radar Type 0 burst.

Note 2: The Channel Closing Transmission Time is comprised of 200 milliseconds starting at the beginning of the Channel Move Time plus any additional intermittent control signals required facilitating a Channel move (an aggregate of 60 milliseconds) during the remainder of the 10 second period. The aggregate duration of control signals will not count quiet periods in between transmissions.

Note 3: During the U-NII Detection Bandwidth detection test, radar type 0 should be used. For each frequency step the minimum percentage of detection is 90 percent. Measurements are performed with no data traffic.

### 13.3. Parameters of radar test waveforms

This section provides the parameters for required test waveforms, minimum percentage of successful detections, and the minimum number of trials that must be used for determining DFS conformance. Step intervals of 0.1 microsecond for Pulse Width, 1 microsecond for PRI, 1 MHz for chirp width and 1 for the number of pulses will be utilized for the random determination of specific test waveforms.

Table 5 Short Pulse Radar Test Waveforms

Radar Type	Pulse Width (μsec)	PRI (μsec)	Number of Pulses	Minimum Percentage of Successful Detection	Minimum Number of Trials
0	1	1428	18	See Note 1	See Note 1
1	1	Test A	Roundup $\left\{ \left( \frac{1}{360} \right) \cdot \left( \frac{19 \cdot 10^6}{\text{PRI}_{\mu\text{sec}}} \right) \right\}$	60%	30
		Test B			
2	1-5	150-230	23-29	60%	30
3	6-10	200-500	16-18	60%	30
4	11-20	200-500	12-16	60%	30
Aggregate (Radar Types 1-4)				80%	120
<p>Note 1: Short Pulse Radar Type 0 should be used for the detection bandwidth test, channel move time, and channel closing time tests.</p> <p>Test A: 15 unique PRI values randomly selected from the list of 23 PRI values in Table 5a</p> <p>Test B: 15 unique PRI values randomly selected within the range of 518-3066 μsec, with a minimum increment of 1 μsec, excluding PRI values selected in Test A</p>					

A minimum of 30 unique waveforms are required for each of the Short Pulse Radar Types 2 through 4. If more than 30 waveforms are used for Short Pulse Radar Types 2 through 4, then each additional waveform must also be unique and not repeated from the previous waveforms. If more than 30 waveforms are used for Short Pulse Radar Type 1, then each additional waveform is generated with Test B and must also be unique and not repeated from the previous waveforms in Tests A or B. Test aggregate is average of the percentage of successful detections of short pulse radar types 1-4

### 13.4. Calibration of radar waveform

Radar Waveform Calibration Procedure:

- (1) A 50 ohm load is connected in place of the spectrum analyzer, and the spectrum analyzer is connected to place of the master
- (2) The interference Radar Detection Threshold Level is  $-62\text{dBm} + 0\text{dBi} + 1\text{dB} = -61\text{dBm}$  that had been taken into account the output power range and antenna gain.
- (3) The following equipment setup was used to calibrate the conducted radar waveform. A vector signal generator was utilized to establish the test signal level for radar type 0. During this process there were no transmissions by either the master or client device. The spectrum analyzer was switched to the zero spans (time domain) at the frequency of the radar waveform generator. Peak detection was used. The spectrum analyzer resolution bandwidth (RBW) and video bandwidth (VBW) were set to 3 MHz. The spectrum analyzer had offset  $-1.0\text{dB}$  to compensate RF cable loss  $1.0\text{dB}$ .
- (4) The vector signal generator amplitude was set so that the power level measured at the spectrum analyzer was  $-62\text{dBm} + 0\text{dBi} + 1\text{dB} = -61\text{dBm}$ . Capture the spectrum analyzer plots on short pulse radar waveform.

Conducted Calibration Setup:

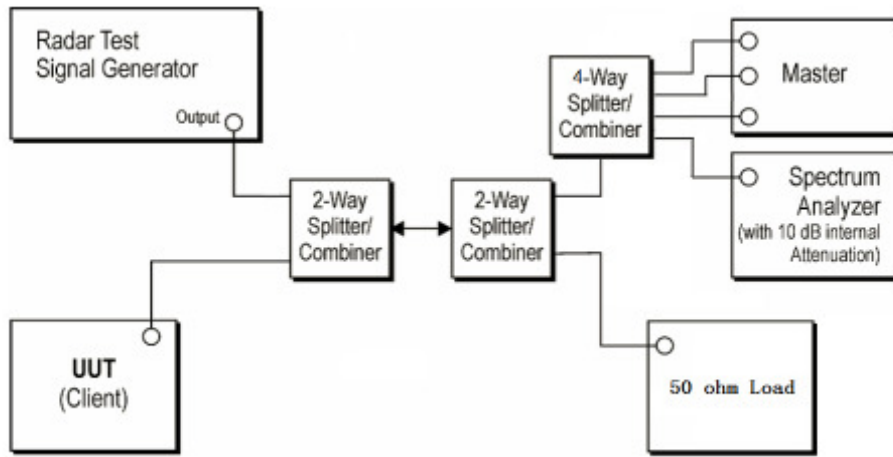

Radar Waveform Calibration Result:

Radar Type 0

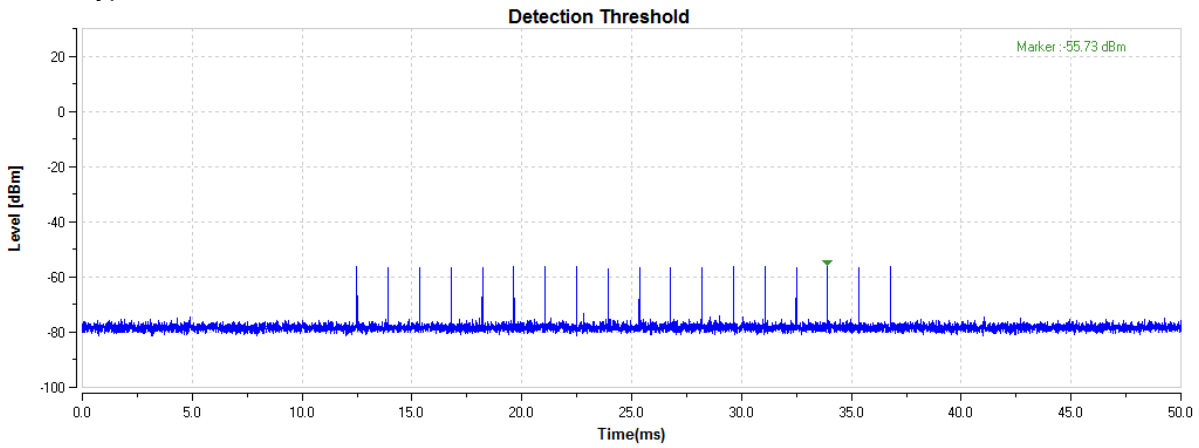

Trial List Table - FCC-13-22

Save Load | ↑ Trigger ↓ Download All

Sample Rate 10 MHz

Trial List

	Trial Id	Radar Type	Pulse Width (us)	PRI (us)	Number of Pulses	Waveform Length (us)
Download	0	Type 0	1.0	1428.0	18	25704.0
Download	1	Type 0	1.0	1428.0	18	25704.0
Download	2	Type 0	1.0	1428.0	18	25704.0
Download	3	Type 0	1.0	1428.0	18	25704.0
Download	4	Type 0	1.0	1428.0	18	25704.0
Download	5	Type 0	1.0	1428.0	18	25704.0
Download	6	Type 0	1.0	1428.0	18	25704.0
Download	7	Type 0	1.0	1428.0	18	25704.0
Download	8	Type 0	1.0	1428.0	18	25704.0
Download	9	Type 0	1.0	1428.0	18	25704.0
Download	10	Type 0	1.0	1428.0	18	25704.0
Download	11	Type 0	1.0	1428.0	18	25704.0
Download	12	Type 0	1.0	1428.0	18	25704.0
Download	13	Type 0	1.0	1428.0	18	25704.0
Download	14	Type 0	1.0	1428.0	18	25704.0
Download	15	Type 0	1.0	1428.0	18	25704.0
Download	16	Type 0	1.0	1428.0	18	25704.0
Download	17	Type 0	1.0	1428.0	18	25704.0
Download	18	Type 0	1.0	1428.0	18	25704.0
Download	19	Type 0	1.0	1428.0	18	25704.0
Download	20	Type 0	1.0	1428.0	18	25704.0
Download	21	Type 0	1.0	1428.0	18	25704.0
Download	22	Type 0	1.0	1428.0	18	25704.0
Download	23	Type 0	1.0	1428.0	18	25704.0
Download	24	Type 0	1.0	1428.0	18	25704.0
Download	25	Type 0	1.0	1428.0	18	25704.0
Download	26	Type 0	1.0	1428.0	18	25704.0
Download	27	Type 0	1.0	1428.0	18	25704.0
Download	28	Type 0	1.0	1428.0	18	25704.0

Radar Type 2

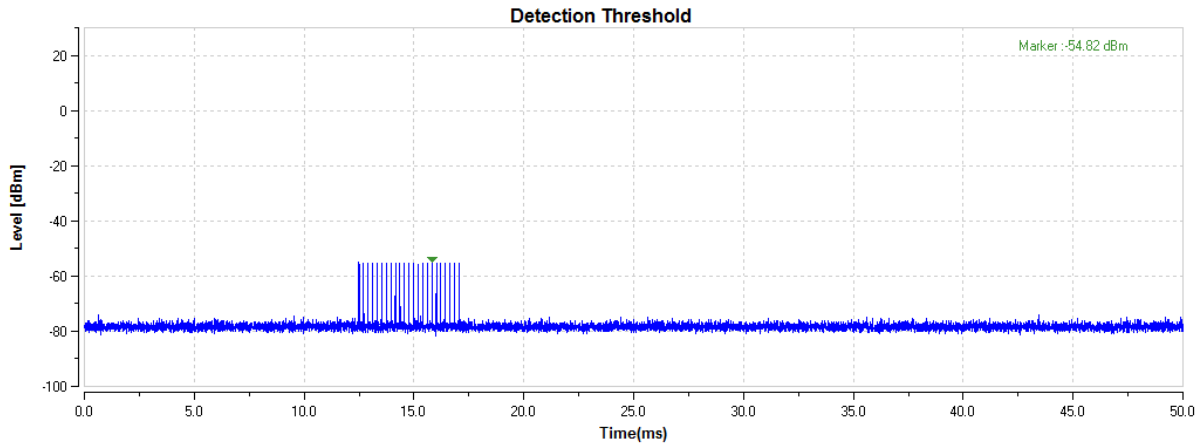

Trial List Table - FCC-13-22

Save Load Trigger Download All

Sample Rate 10 MHz

	Trial Id	Radar Type	Pulse Width (us)	PRI (us)	Number of Pulses	Waveform Length (us)
Download	0	Type 2	3.2	179.0	26	4654.0
Download	1	Type 2	1.1	207.0	23	4761.0
Download	2	Type 2	2.1	230.0	24	5520.0
Download	3	Type 2	4.8	200.0	29	5800.0
Download	4	Type 2	3.9	214.0	28	5992.0
Download	5	Type 2	2.9	222.0	26	5772.0
Download	6	Type 2	3.2	204.0	26	5304.0
Download	7	Type 2	2.5	192.0	25	4800.0
Download	8	Type 2	3.1	164.0	26	4264.0
Download	9	Type 2	1.2	156.0	23	3588.0
Download	10	Type 2	3.9	210.0	27	5670.0
Download	11	Type 2	4.6	201.0	29	5829.0
Download	12	Type 2	3.2	162.0	26	4212.0
Download	13	Type 2	2.2	197.0	25	4925.0
Download	14	Type 2	4.5	163.0	29	4727.0
Download	15	Type 2	3.0	203.0	26	5278.0
Download	16	Type 2	5.0	168.0	29	4872.0
Download	17	Type 2	2.4	217.0	25	5425.0
Download	18	Type 2	2.9	191.0	26	4966.0
Download	19	Type 2	2.3	166.0	25	4150.0
Download	20	Type 2	3.7	150.0	27	4050.0
Download	21	Type 2	2.2	176.0	25	4400.0
Download	22	Type 2	4.9	195.0	29	5655.0
Download	23	Type 2	2.9	202.0	26	5252.0
Download	24	Type 2	2.5	178.0	25	4450.0
Download	25	Type 2	1.1	206.0	23	4738.0
Download	26	Type 2	3.8	155.0	27	4185.0
Download	27	Type 2	4.7	157.0	29	4553.0
Download	28	Type 2	2.4	224.0	25	5600.0

Radar Type 3

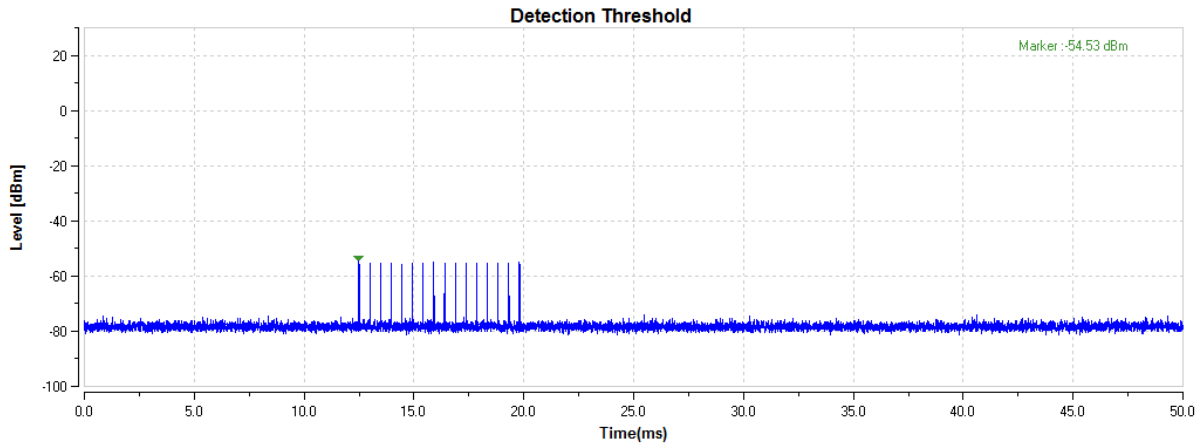

Trial List Table - FCC-13-22

Save Load Trigger Download All

Sample Rate 10 MHz

	Trial Id	Radar Type	Pulse Width (us)	PRI (us)	Number of Pulses	Waveform Length (us)
Download	0	Type 3	8.2	355.0	17	6035.0
Download	1	Type 3	6.1	487.0	16	7792.0
Download	2	Type 3	7.1	344.0	16	5504.0
Download	3	Type 3	9.8	288.0	18	5184.0
Download	4	Type 3	8.9	230.0	18	4140.0
Download	5	Type 3	7.9	432.0	17	7344.0
Download	6	Type 3	8.2	207.0	17	3519.0
Download	7	Type 3	7.5	443.0	17	7531.0
Download	8	Type 3	8.1	439.0	17	7463.0
Download	9	Type 3	6.2	223.0	16	3568.0
Download	10	Type 3	8.9	208.0	18	3744.0
Download	11	Type 3	9.6	463.0	18	8334.0
Download	12	Type 3	8.2	441.0	17	7497.0
Download	13	Type 3	7.2	323.0	16	5168.0
Download	14	Type 3	9.5	297.0	18	5346.0
Download	15	Type 3	8.0	412.0	17	7004.0
Download	16	Type 3	10.0	324.0	18	5832.0
Download	17	Type 3	7.4	271.0	17	4607.0
Download	18	Type 3	7.9	349.0	17	5933.0
Download	19	Type 3	7.3	409.0	16	6544.0
Download	20	Type 3	8.7	373.0	18	6714.0
Download	21	Type 3	7.2	254.0	16	4064.0
Download	22	Type 3	9.9	274.0	18	4932.0
Download	23	Type 3	7.9	278.0	17	4726.0
Download	24	Type 3	7.5	317.0	17	5389.0
Download	25	Type 3	6.1	260.0	16	4160.0
Download	26	Type 3	8.8	211.0	18	3798.0
Download	27	Type 3	9.7	272.0	18	4896.0
Download	28	Type 3	7.4	264.0	17	4488.0

Radar Type 4

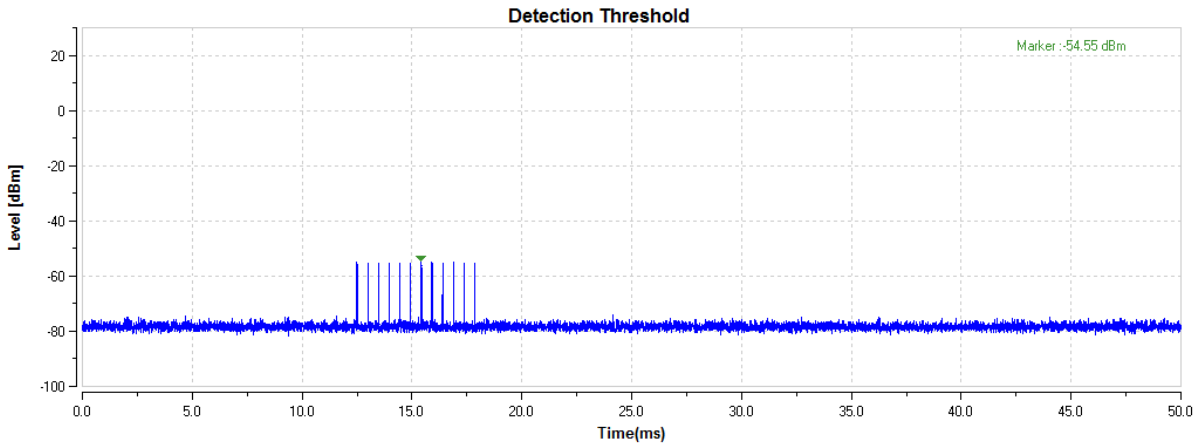

Trial List Table - FCC-13-22

Save Load Trigger Download All

Sample Rate 10 MHz

	Trial Id	Radar Type	Pulse Width (us)	PRI (us)	Number of Pulses	Waveform Length (us)
Download	0	Type 4	16.0	355.0	14	4970.0
Download	1	Type 4	11.3	487.0	12	5844.0
Download	2	Type 4	13.5	344.0	13	4472.0
Download	3	Type 4	19.4	288.0	16	4608.0
Download	4	Type 4	17.5	230.0	15	3450.0
Download	5	Type 4	15.3	432.0	14	6048.0
Download	6	Type 4	15.9	207.0	14	2898.0
Download	7	Type 4	14.3	443.0	13	5759.0
Download	8	Type 4	15.8	439.0	14	6146.0
Download	9	Type 4	11.5	223.0	12	2676.0
Download	10	Type 4	17.4	208.0	15	3120.0
Download	11	Type 4	19.0	463.0	16	7408.0
Download	12	Type 4	16.0	441.0	14	6174.0
Download	13	Type 4	13.8	323.0	13	4199.0
Download	14	Type 4	18.9	297.0	16	4752.0
Download	15	Type 4	15.5	412.0	14	5768.0
Download	16	Type 4	19.9	324.0	16	5184.0
Download	17	Type 4	14.1	271.0	13	3523.0
Download	18	Type 4	15.2	349.0	14	4886.0
Download	19	Type 4	13.8	409.0	13	5317.0
Download	20	Type 4	17.1	373.0	15	5595.0
Download	21	Type 4	13.8	254.0	13	3302.0
Download	22	Type 4	19.8	274.0	16	4384.0
Download	23	Type 4	15.3	278.0	14	3892.0
Download	24	Type 4	14.5	317.0	13	4121.0
Download	25	Type 4	11.3	260.0	12	3120.0
Download	26	Type 4	17.3	211.0	15	3165.0
Download	27	Type 4	19.2	272.0	16	4352.0
Download	28	Type 4	14.2	264.0	13	3432.0

Radar Type 5

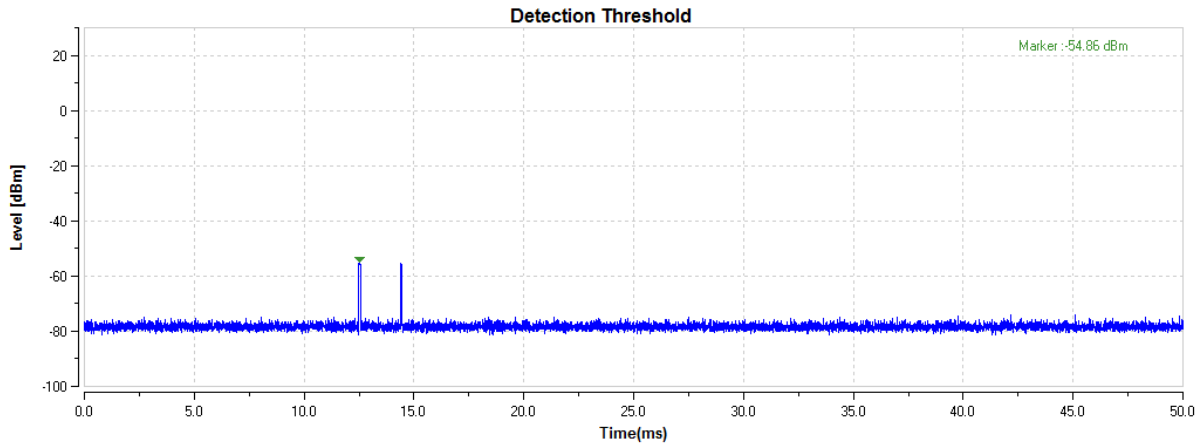

Trial List Table - FCC-13-22

Save Load Trigger Download All

Sample Rate: 100 MHz UUT Channel Center Frequency: 5.5 GHz Radar Detection Bandwidth: 5 MHz

Trial List								
		Trial Id	Radar Type	Number of Bursts	Burst Period (s)	Waveform Length (s)	Center Frequency (GHz)	
Download	0	Type 5	15	0.8000000	12.0000000	5.500000000		
Download	1	Type 5	8	1.5000000	12.0000000	5.500000000		
Download	2	Type 5	11	1.0909091	12.0000000	5.500000000		
Download	3	Type 5	20	0.6000000	12.0000000	5.500000000		
Download	4	Type 5	17	0.7058824	12.0000000	5.500000000		
Download	5	Type 5	14	0.8571429	12.0000000	5.500000000		
Download	6	Type 5	15	0.8000000	12.0000000	5.500000000		
Download	7	Type 5	12	1.0000000	12.0000000	5.500000000		
Download	8	Type 5	14	0.8571429	12.0000000	5.500000000		
Download	9	Type 5	8	1.5000000	12.0000000	5.500000000		
Download	10	Type 5	17	0.7058824	12.0000000	5.503900000		
Download	11	Type 5	19	0.6315789	12.0000000	5.505100000		
Download	12	Type 5	15	0.8000000	12.0000000	5.502700000		
Download	13	Type 5	12	1.0000000	12.0000000	5.501500000		
Download	14	Type 5	19	0.6315789	12.0000000	5.504700000		
Download	15	Type 5	14	0.8571429	12.0000000	5.502300000		
Download	16	Type 5	20	0.6000000	12.0000000	5.505500000		
Download	17	Type 5	12	1.0000000	12.0000000	5.501500000		
Download	18	Type 5	14	0.8571429	12.0000000	5.502300000		
Download	19	Type 5	12	1.0000000	12.0000000	5.501500000		
Download	20	Type 5	16	0.7500000	12.0000000	5.496500000		
Download	21	Type 5	12	1.0000000	12.0000000	5.498900000		
Download	22	Type 5	20	0.6000000	12.0000000	5.494500000		
Download	23	Type 5	14	0.8571429	12.0000000	5.497700000		
Download	24	Type 5	13	0.9230769	12.0000000	5.498100000		
Download	25	Type 5	8	1.5000000	12.0000000	5.500500000		
Download	26	Type 5	17	0.7058824	12.0000000	5.496100000		
Download	27	Type 5	19	0.6315789	12.0000000	5.494900000		
Download	28	Type 5	12	1.0000000	12.0000000	5.498500000		

Radar Type 6

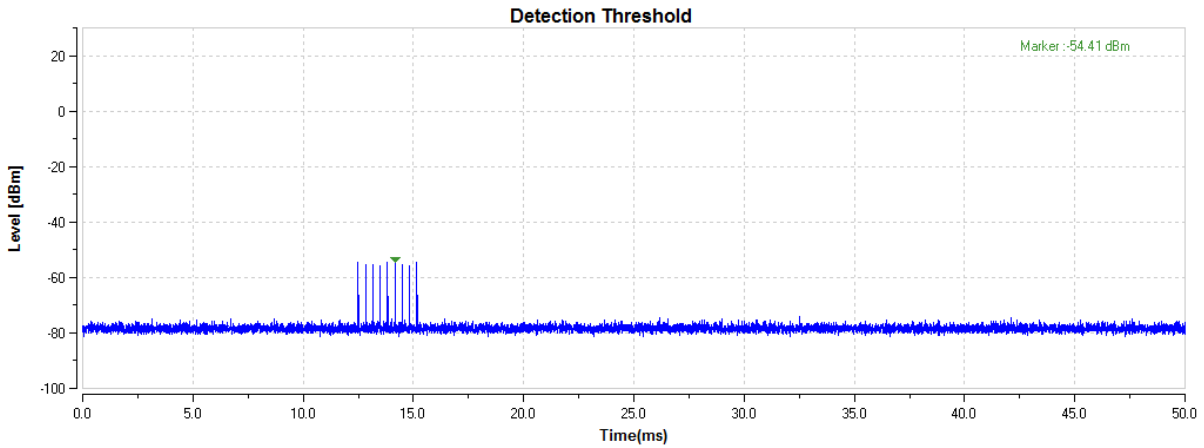

Trial List Table - FCC-13-22

Save Load Trigger Download All

Sample Rate 200 MHz Center Frequency 5500 MHz Channel Bandwidth 160 MHz

Trial List									
		Trial Id	Radar Type	Pulse Width (us)	PRI (us)	Pulses per Hop	Hopping Rate (kHz)	Hopping Sequence Length (ms)	Visible Frequency Number
+	Download	0	Type 6	1.0	333.3	9	0.3333	300.0000000	32
+	Download	1	Type 6	1.0	333.3	9	0.3333	300.0000000	27
+	Download	2	Type 6	1.0	333.3	9	0.3333	300.0000000	25
+	Download	3	Type 6	1.0	333.3	9	0.3333	300.0000000	33
+	Download	4	Type 6	1.0	333.3	9	0.3333	300.0000000	37
+	Download	5	Type 6	1.0	333.3	9	0.3333	300.0000000	30
+	Download	6	Type 6	1.0	333.3	9	0.3333	300.0000000	33
+	Download	7	Type 6	1.0	333.3	9	0.3333	300.0000000	27
+	Download	8	Type 6	1.0	333.3	9	0.3333	300.0000000	33
+	Download	9	Type 6	1.0	333.3	9	0.3333	300.0000000	30
+	Download	10	Type 6	1.0	333.3	9	0.3333	300.0000000	37
+	Download	11	Type 6	1.0	333.3	9	0.3333	300.0000000	36
+	Download	12	Type 6	1.0	333.3	9	0.3333	300.0000000	38
+	Download	13	Type 6	1.0	333.3	9	0.3333	300.0000000	35
+	Download	14	Type 6	1.0	333.3	9	0.3333	300.0000000	28
+	Download	15	Type 6	1.0	333.3	9	0.3333	300.0000000	37
+	Download	16	Type 6	1.0	333.3	9	0.3333	300.0000000	35
+	Download	17	Type 6	1.0	333.3	9	0.3333	300.0000000	37
+	Download	18	Type 6	1.0	333.3	9	0.3333	300.0000000	27
+	Download	19	Type 6	1.0	333.3	9	0.3333	300.0000000	34
+	Download	20	Type 6	1.0	333.3	9	0.3333	300.0000000	35
+	Download	21	Type 6	1.0	333.3	9	0.3333	300.0000000	37
+	Download	22	Type 6	1.0	333.3	9	0.3333	300.0000000	41
+	Download	23	Type 6	1.0	333.3	9	0.3333	300.0000000	36
+	Download	24	Type 6	1.0	333.3	9	0.3333	300.0000000	29
+	Download	25	Type 6	1.0	333.3	9	0.3333	300.0000000	32
+	Download	26	Type 6	1.0	333.3	9	0.3333	300.0000000	30
+	Download	27	Type 6	1.0	333.3	9	0.3333	300.0000000	31

### 13.5. Channel closing transmission time, channel move time and non-occupancy period

Block diagram of test setup Test Procedure:

- (1) The radar pulse generator is setup to provide a pulse at frequency that the master and client are operating. A type 0 radar pulse with a 1us pulse width and a 1428us PRI is used for the testing.
- (2) The vector signal generator is adjusted to provide the radar burst (18 pulses) at the level of approximately -61dBm at the antenna port of the master device.
- (3) A trigger is provided from the pulse generator to the DFS monitoring system in order to capture the traffic and the occurrence of the radar pulse.
- (4) EUT will associate with the master at channel. The file "iperf.exe" specified by the FCC is streamed from the PC 2 through the master and the client device to the PC 1 and played in full motion video using Test Software in order to properly load the network for the entire period of the test.
- (5) When radar burst with a level equal to the DFS Detection Threshold +1dB is generated on the operating channel of the U-NII device. At time T0 the radar waveform generator sends a burst of pulse of the radar waveform at Detection Threshold +1dB.
- (6) Observe the transmissions of the EUT at the end of the radar Burst on the Operating Channel. Measure and record the transmissions from the UUT during the observation time (Channel Move Time). One 15 seconds plot is reported for the Short Pulse Radar Type 0. The plot for the Short Pulse Radar Types start at the end of the radar burst. The Channel Move Time will be calculated based on the zoom in 600ms plot of the Short Pulse Radar Type.
- (7) Measurement of the aggregate duration of the Channel Closed Transmission Time method. With the
- (8) spectrum analyzer set to zero span tuned to the center frequency of the EUT operating channel at the radar simulated frequency, peak detection, and max hold, the dwell time per bin is given by:  
$$\text{Dwell (0.3ms)} = S (12000\text{ms}) / B (4000);$$
 where Dwell is the dwell time per spectrum analyzer sampling bin, S is sweep time and B is the number of spectrum analyzer sampling bins. An upper bound of the aggregate duration of the intermittent control signals of Channel Closing Transmission Time is calculated by:  
$$C (\text{ms}) = N \times \text{Dwell (0.3ms)};$$
 where C is the Closing Time, N is the number of spectrum analyzer sampling bins (intermittent control signals) showing a U-NII transmission and Dwell is the dwell time per bin.

Measurement the EUT for more than 30 minutes following the channel move time to verify that no transmission or beacons occur on this channel.

### 13.6. Test setup

Setup for Client with injection at the Master

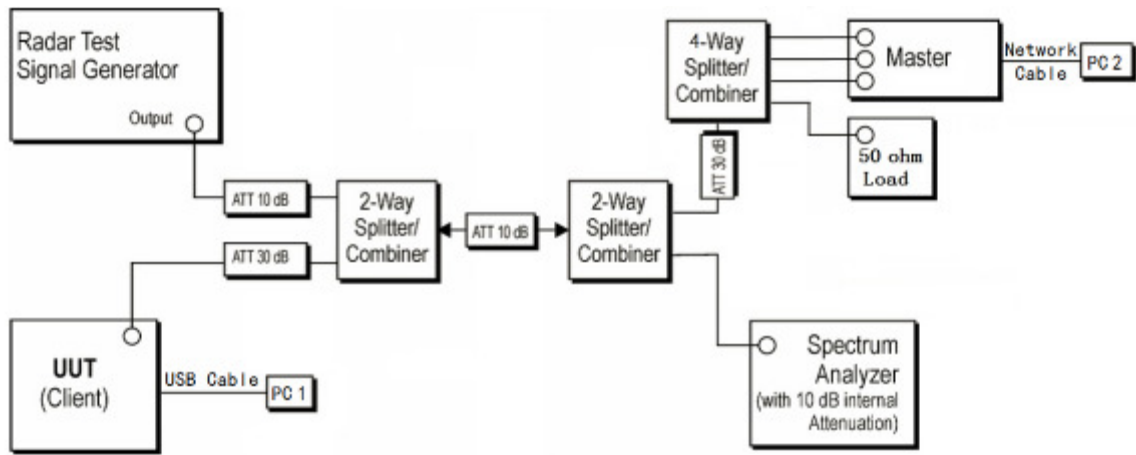

**13.7. Test result**

BW/Channel	Test Item	Test Result	Limit	Results
80M/5530MHz	Channel Move Time	0.558s	< 10 s	pass
	Channel Closing Transmission Time	0.001s	< 1s	pass

Test plots as follows:

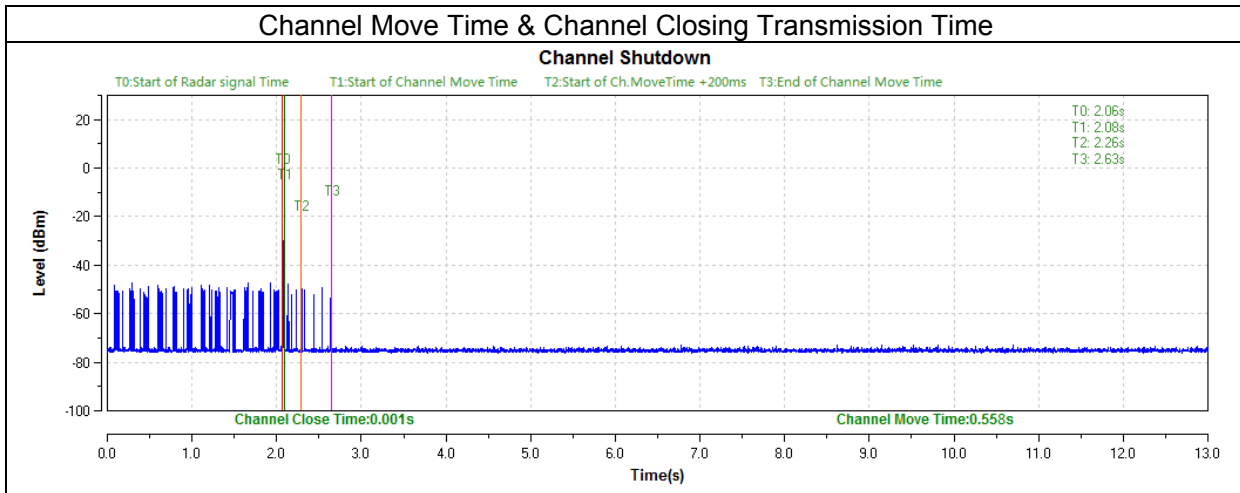

BW/Channel	Test Item	Test Result	Limit	Results
80M/5530MHz	Non-Occupancy Period	>30min	30min	pass

Non-Occupancy Period

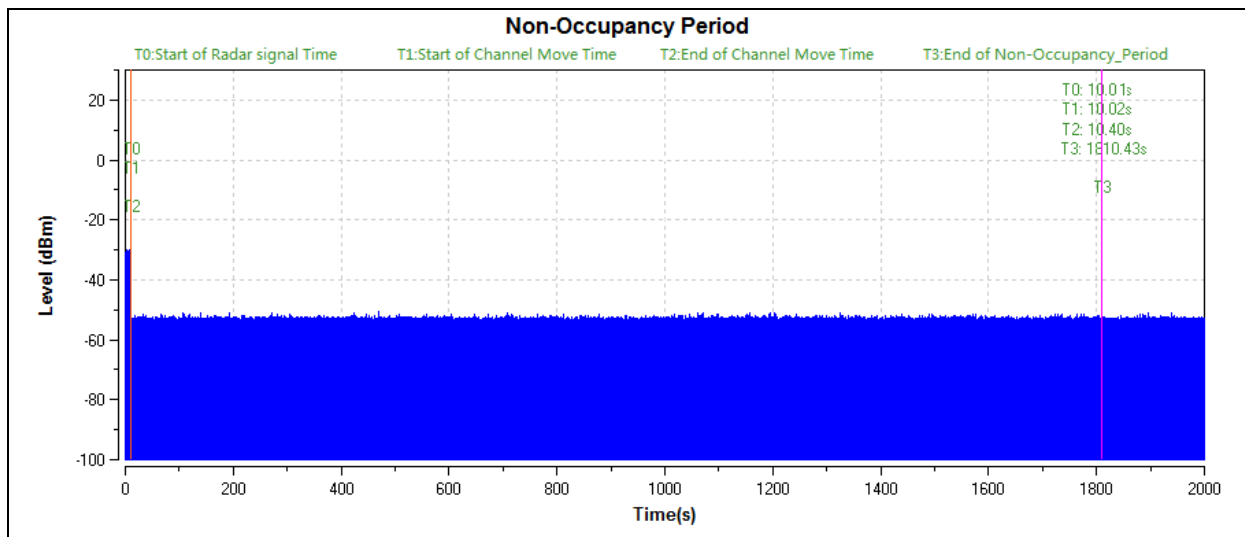

**END OF REPORT**