



## Test Report

Product Name : Vehicle device wireless audio device

Model No. : DP2US

FCC ID : APIDP2US

Applicant : Harman Kardon Inc

Address : 250 Crossways Park Drive Woodbury, NY 11797

Date of Receipt : Jan. 24, 2007

Issued Date : Feb. 14, 2007

Report No. : 071L127-RFUSP02V01

The Test Results relate only to the samples tested.

The test report shall not be reproduced except in full without the written approval of Quietek Corporation.

This report must not be used to claim product endorsement by NVLAP any agency of the U.S. Government

# Test Report Certification

Test Date : Feb. 14, 2007

Report No. : 071L127-RFUSP02V01



Accredited by NIST (NVLAP)

NVLAP Lab Code: 200533-0

Product Name : Vehicle device wireless audio device  
Applicant : Harman Kardon Inc  
Address : 250 Crossways Park Drive Woodbury, NY 11797  
Manufacturer : Kinpo Electronics, Inc.  
Model No. : DP2US  
FCC ID. : APIDP2US  
Rated Voltage : AC 120V/60Hz  
Working Voltage : DC 11.8 - 23V  
Trade Name : harman kardon  
Measurement Standard : FCC CFR Title 47 Part 15 Subpart C: 2005  
Measurement Procedure : ANSI C63.4: 2003  
Test Result : Complied



The Test Results relate only to the samples tested.

The test report shall not be reproduced except in full without the written approval of Quietek Corporation.

This report must not be used to claim product endorsement by NVLAP any agency of the U.S. Government

Documented By : Michelle Lin  
( Michelle Lin )

Tested By : Dino Chen  
( Dino Chen )

Approved By : Gene Chang  
( Gene Chang )

## TABLE OF CONTENTS

Description	Page
<b>1. GENERAL INFORMATION .....</b>	<b>4</b>
1.1. EUT Description.....	4
1.2. Operation Description .....	6
1.3. Test System Details .....	7
1.4. Configuration of Tested System .....	7
1.5. EUT Exercise Software .....	7
1.6. Test Facility .....	8
<b>2. Conducted Emission .....</b>	<b>9</b>
2.1. Test Equipments .....	9
2.2. Test Setup .....	9
2.3. Limits .....	9
2.4. Test Procedure .....	10
2.5. Uncertainty .....	10
2.6. Test Result of Conducted Emission.....	10
<b>3. Radiated Emission .....</b>	<b>11</b>
3.1. Test Equipment.....	11
3.2. Test Setup .....	11
3.3. Limits .....	12
3.4. Test Procedure .....	13
3.5. Uncertainty .....	13
3.6. Test Result of Radiated Emission.....	14
<b>4. Occupied Bandwidth .....</b>	<b>22</b>
4.1. Test Equipment.....	22
4.2. Test Setup .....	22
4.3. Limits .....	22
4.4. Uncertainty .....	22
4.5. Test Result of Occupied Bandwidth.....	23
<b>5. Band Edge .....</b>	<b>25</b>
5.1. Test Equipment.....	25
5.2. Test Setup .....	25
5.3. Limits .....	26
5.4. Test Procedure .....	26
5.5. Uncertainty .....	26
5.6. Test Result of Band Edge .....	27
<b>6. EMI Reduction Method During Compliance Testing.....</b>	<b>31</b>
Attachment 1: EUT Test Photographs	
Attachment 2: EUT Detailed Photographs	

## 1. GENERAL INFORMATION

### 1.1. EUT Description

Product Name	Vehicle device wireless audio device
Trade Name	harman kardon
Model No.	DP2US
Frequency Range	88.1 - 107.5MHz
Channel Number	98
Type of Modulation	FM
Antenna Type	Monopole
Channel Selection	Manual Switch

#### Frequency of Each Channel

Channel	Frequency	Channel	Frequency	Channel	Frequency	Channel	Frequency
Channel 1:	88.1 MHz	Channel 2:	88.3 MHz	Channel 3:	88.5 MHz	Channel 4:	88.7 MHz
Channel 5:	88.9 MHz	Channel 6:	89.1 MHz	Channel 7:	89.3 MHz	Channel 8:	89.5 MHz
Channel 9:	89.7 MHz	Channel 10:	89.9 MHz	Channel 11:	90.1 MHz	Channel 12:	90.3 MHz
Channel 13:	90.5 MHz	Channel 14:	90.7 MHz	Channel 15:	90.9 MHz	Channel 16:	91.1 MHz
Channel 17:	91.3 MHz	Channel 18:	91.5 MHz	Channel 19:	91.7 MHz	Channel 20:	91.9 MHz
Channel 21:	92.1 MHz	Channel 22:	92.3 MHz	Channel 23:	92.5 MHz	Channel 24:	92.7 MHz
Channel 25:	92.9 MHz	Channel 26:	93.1 MHz	Channel 27:	93.3 MHz	Channel 28:	93.5 MHz
Channel 29:	93.7 MHz	Channel 30:	93.9 MHz	Channel 31:	94.1 MHz	Channel 32:	94.3 MHz
Channel 33:	94.5 MHz	Channel 34:	94.7 MHz	Channel 35:	94.9 MHz	Channel 36:	95.1 MHz
Channel 37:	95.3 MHz	Channel 38:	95.5 MHz	Channel 39:	95.7 MHz	Channel 40:	95.9 MHz
Channel 41:	96.1 MHz	Channel 42:	96.3 MHz	Channel 43:	96.5 MHz	Channel 44:	96.7 MHz
Channel 45:	96.9 MHz	Channel 46:	97.1 MHz	Channel 47:	97.3 MHz	Channel 48:	97.5 MHz
Channel 49:	97.7 MHz	Channel 50:	97.9 MHz	Channel 51:	98.1 MHz	Channel 52:	98.3 MHz
Channel 53:	98.5 MHz	Channel 54:	98.7 MHz	Channel 55:	98.9 MHz	Channel 56:	99.1 MHz
Channel 57:	99.3 MHz	Channel 58:	99.5 MHz	Channel 59:	99.7 MHz	Channel 60:	99.9 MHz
Channel 61:	100.1 MHz	Channel 62:	100.3 MHz	Channel 63:	100.5 MHz	Channel 64:	100.7 MHz
Channel 65:	100.9 MHz	Channel 66:	101.1 MHz	Channel 67:	101.3 MHz	Channel 68:	101.5 MHz
Channel 69:	101.7 MHz	Channel 70:	101.9 MHz	Channel 71:	102.1 MHz	Channel 72:	102.3 MHz
Channel 73:	102.5 MHz	Channel 74:	102.7 MHz	Channel 75:	102.9 MHz	Channel 76:	103.1 MHz
Channel 77:	103.3 MHz	Channel 78:	103.5 MHz	Channel 79:	103.7 MHz	Channel 80:	103.9 MHz
Channel 81:	104.1 MHz	Channel 82:	104.3 MHz	Channel 83:	104.5 MHz	Channel 84:	104.7 MHz
Channel 85:	104.9 MHz	Channel 86:	105.1 MHz	Channel 87:	105.3 MHz	Channel 88:	105.5 MHz
Channel 89:	105.7 MHz	Channel 90:	105.9 MHz	Channel 91:	106.1 MHz	Channel 92:	106.3 MHz
Channel 93:	106.5 MHz	Channel 94:	106.7 MHz	Channel 95:	106.9 MHz	Channel 96:	107.1 MHz
Channel 97:	107.3 MHz	Channel 98:	107.5 MHz				

## Note:

1. This device is an Vehicle device wireless audio device with a built-in FM transmitter.
2. Regarding to the operation frequency, the lowest, middle, and highest channels are selected to perform the test.
3. These tests were conducted on a sample of the equipment for the purpose of demonstrating compliance with Part 15 Subpart C Paragraph 15.239.
4. Quietek verified the construction and function in typical operation, and then shown in this test report.

Mode 1: Transmitter

## 1.2. Operation Description

The EUT is an Vehicle device wireless audio device. The operation frequency is from 88.1 to 107.5MHz with FM modulation. 98 manually selectable channels were built in the EUT. The channels are separated by 200kHz. The signals are modulated by FM. RF signals are transmitted from the monopole antenna. DC 12V shall be provided for EUT operation.

### 1.3. Test System Details

The types for all equipment, plus descriptions of all cables used in the tested system (including inserted cards) are:

	Product	Manufacturer	Model No.	Serial No.	Power Cord
(1)	iPod	Apple	A1137	5K6351TDTJT	N/A
(2)	DC 12V Battery	Chen Guang	66N50	N/A	N/A

Signal Cable Type	Signal cable Description
A. USB Cable	Non-Shielded, 1m
B. USB Cable	Non-Shielded, 2.7m

### 1.4. Configuration of Tested System

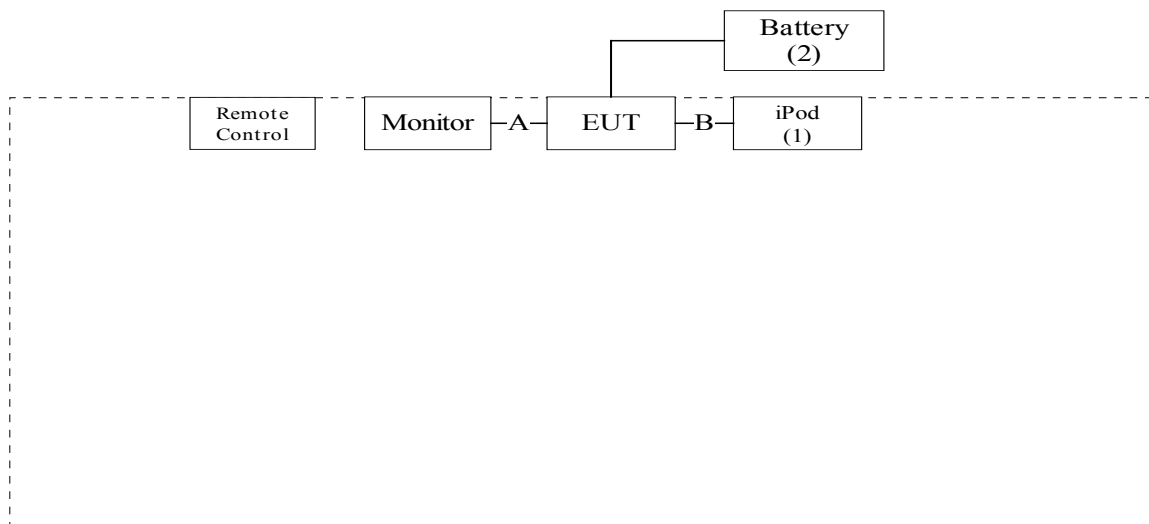

### 1.5. EUT Exercise Software

- (1) Setup the EUT as shown in Section 1.4.
- (2) Play music files on the iPod player.
- (3) The EUT will start transmitting RF signals.
- (4) Verify that the EUT works properly.

**1.6. Test Facility**

Ambient conditions in the laboratory:

Items	Required (IEC 68-1)	Actual
Temperature (°C)	15-35	20-35
Humidity (%RH)	25-75	50-65
Barometric pressure (mbar)	860-1060	950-1000

Site Description: Federal Communications Commission  
 FCC Engineering Laboratory  
 7435 Oakland Mills Road  
 Columbia, MD 21046  
 Reference 31040/SIT1300F2



Accreditation on NVLAP  
 NVLAP Lab Code: 200533-0



Site Name: Quietek Corporation  
 Site Address: No. 5-22, Ruei-Shu Valley, Ruei-Ping Tsuen,  
 Lin-Kou Shiang, Taipei,  
 Taiwan, R.O.C.  
 TEL: 886-2-8601-3788 / FAX : 886-2-8601-3789  
 E-Mail : [service@quietek.com](mailto:service@quietek.com)



0914

ILAC MRA

## 2. Conducted Emission

### 2.1. Test Equipments

The following test equipment are used during the conducted emission test:

Item	Instrument	Manufacturer	Type No./Serial No	Last Cal.	Remark
1	Test Receiver	R & S	ESCS 30/825442/17	May, 2006	
2	L.I.S.N.	R & S	ESH3-Z5/825016/6	May, 2006	EUT
3	L.I.S.N.	Kyoritsu	KNW-407/8-1420-3	May, 2006	Peripherals
4	Pulse Limiter	R & S	ESH3-Z2	May, 2006	
5	No.1 Shielded Room			N/A	

Note: All instruments are calibrated every one year.

### 2.2. Test Setup

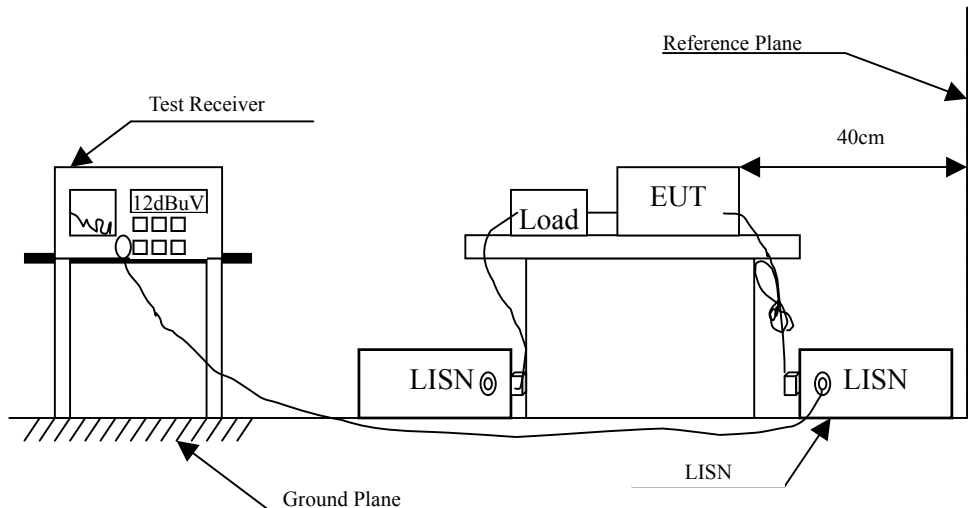

### 2.3. Limits

FCC Part 15 Subpart C Paragraph 15.207 (dBuV) Limit		
Frequency MHz	Limits	
	uV	dBuV
0.15 - 0.50	66-56 <sub>(註)</sub>	56-46 <sub>(註)</sub>
0.50-5.0	56	46
5.0 - 30	60	50

## 2.4. Test Procedure

The EUT and simulators are connected to the main power through a line impedance stabilization network (L.I.S.N.). This provides a 50 ohm /50uH coupling impedance for the measuring equipment. The peripheral devices are also connected to the main power through a LISN that provides a 50ohm /50uH coupling impedance with 50ohm termination. (Please refers to the block diagram of the test setup and photographs.)

Both sides of A.C. line are checked for maximum conducted interference. In order to find the maximum emission, the relative positions of equipment and all of the interface cables must be changed according to ANSI C63.4: 2003 on conducted measurement.

Conducted emissions were investigated over the frequency range from 0.15MHz to 30MHz using a receiver bandwidth of 9kHz.

## 2.5. Uncertainty

$\pm 2.26$  dB

## 2.6. Test Result of Conducted Emission

The EUT is powered by DC. This test is not performed.

### 3. Radiated Emission

#### 3.1. Test Equipment

The following test equipment are used during the radiated emission test:

Test Site	Equipment	Manufacturer	Model No./Serial No.	Last Cal.
<input type="checkbox"/> Site # 1	Test Receiver	R & S	ESVS 10 / 834468/003	May, 2006
	Spectrum Analyzer	Advantest	R3162/ 00803480	May, 2006
	Pre-Amplifier	Advantest	BB525C/ 3307A01812	May, 2006
	Bilog Antenna	SCHAFFNER	CBL6112B / 2697	Sep., 2006
<input type="checkbox"/> Site # 2	Test Receiver	R & S	ESCS 30 / 836858 / 022	May, 2006
	Spectrum Analyzer	Advantest	R3162 / 100803466	May, 2006
	Pre-Amplifier	Advantest	BB525C/3307A01814	May, 2006
	Bilog Antenna	SCHAFFNER	CBL6112B / 2705	May, 2006
	Horn Antenna	ETS	3115 / 0005-6160	Sep., 2006
	Pre-Amplifier	QTK	QTK-AMP-01/ 0001	May, 2006
<input checked="" type="checkbox"/> Site # 3	X Test Receiver	R & S	ESI 26 / 838786/004	May, 2006
	X Spectrum Analyzer	Agilent	E4407B / US39440758	May, 2006
	X Bilog Antenna	SCHAFFNER	CBL6112B / 2697	May, 2006
	X Horn Antenna	Schwarzbeck	BBHA9120D / 305, 306	July, 2006
	X Horn Antenna	Schwarzbeck	BBHA9170 / 208, 209	July, 2006
	X Pre-Amplifier	QTK	QTK-AMP-01 / 0001	July, 2006
	X Pre-Amplifier	QTK	QTK-AMP-03 / 0003	May, 2006
	X Pre-Amplifier	HP	8449B / 3008A01123	July, 2006

- Note: 1. All equipments are calibrated every one year.  
 2. Test equipments marked by "X" are used to measure the final test results.

#### 3.2. Test Setup

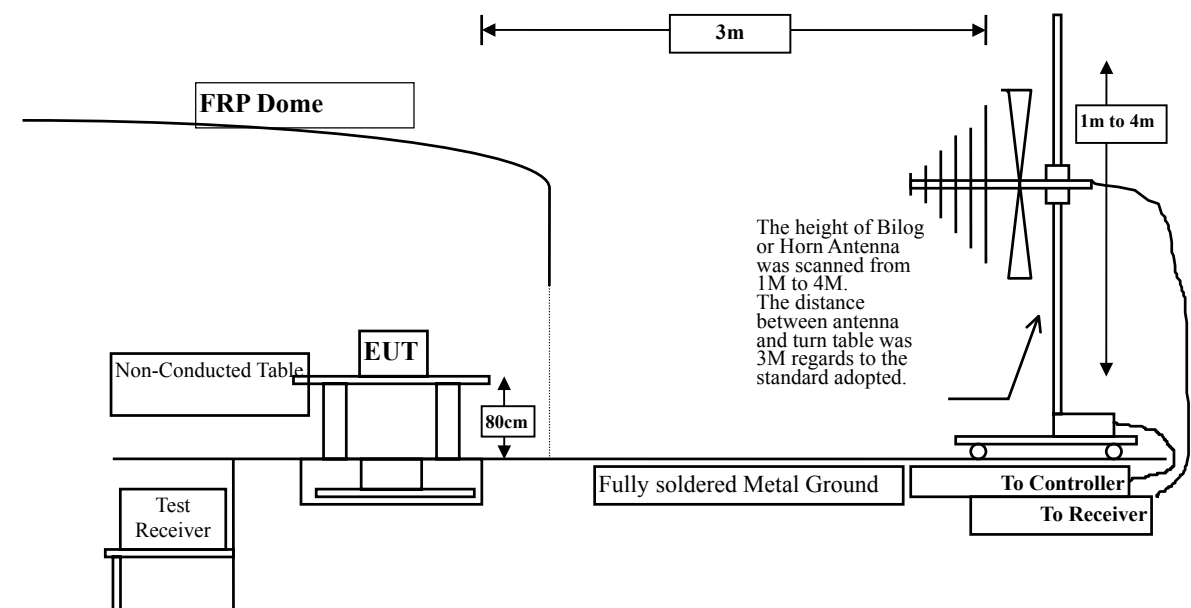

### 3.3. Limits

#### ➤ Fundamental and Harmonics Emission Limits

FCC Part 15 Subpart C Paragraph 15.239 Limits	
Frequency MHz	Field Strength of Fundamental
	(uV/m @3m)
88-108	250

- Remarks :
1. RF Voltage (dBuV/m) = 20 log RF Voltage (uV/m)
  2. Distance refers to the distance in meters between the measuring instrument antenna and the closed point of any part of the device or system.

#### ➤ General Radiated Emission Limits

Emissions radiated outside of the specified frequency bands, except for harmonics, shall be attenuated by at least 50dB below the level of the fundamental or to the general radiated emission limits in paragraph 15.209, whichever is the lesser attenuation.

FCC Part 15 Subpart B Paragraph 15.209 Limits		
Frequency MHz	uV/m @3m	dBuV/m@3m
30-88	100	40
88-216	150	43.5
216-960	200	46
Above 960	500	54

- Remarks :
1. RF Voltage (dBuV/m) = 20 log RF Voltage (uV/m)
  2. In the Above Table, the tighter limit applies at the band edges.
  3. Distance refers to the distance in meters between the measuring instrument antenna and the closed point of any part of the device or system.

### 3.4. Test Procedure

The EUT and its simulators are placed on a turn table which is 0.8 meter above ground. The turn table can rotate 360 degrees to determine the position of the maximum emission level. The EUT was positioned such that the distance from antenna to the EUT was 3 meters.

The antenna can move up and down between 1 meter and 4 meters to find out the maximum emission level.

Both horizontal and vertical polarization of the antenna are set on measurement. In order to find the maximum emission, all of the interface cables must be manipulated according to ANSI C63.4: 2003 on radiated measurement.

Radiated emissions were investigated over the frequency range from 30MHz to 1GHz using a receiver bandwidth of 120kHz. Radiated was performed at an antenna to EUT distance of 3 meters.

The frequency range from 30MHz to 10th harmonics is checked.

### 3.5. Uncertainty

± 3.9 dB above 1GHz

± 3.8 dB below 1GHz

### 3.6. Test Result of Radiated Emission

Product : Vehicle device wireless audio device  
 Test Item : Fundamental Radiated Emission  
 Test Site : No.3 OATS  
 Test Mode : Mode 1: Transmitter

Frequency MHz	Correct Factor dB	Reading Level dBUV	Measurement Level dBUV/m	Margin dB	Limit dBUV/m
<b>Horizontal</b>					
<b>Peak Detector:</b>					
88.100	15.119	24.280	39.399	-28.551	67.950
98.100	14.306	25.110	39.416	-28.534	67.950
107.500	13.638	25.590	39.228	-28.722	67.950
<b>Average Detector:</b>					
--					
<b>Vertical</b>					
<b>Peak Detector:</b>					
88.100	15.119	25.260	40.379	-27.571	67.950
98.100	14.306	26.490	40.796	-27.154	67.950
107.500	13.638	26.643	40.281	-27.669	67.950
<b>Average Detector:</b>					
--					

Note:

1. The reading levels below 1GHz and above 1GHz are quasi-peak values and peak/average values, respectively.
2. Receiver setting (Peak Detector) : RBW:120KHz ◦
3. Receiver setting (AVG Detector) : RBW:120KHz ◦
4. Emission Level = Reading Level + Correct Factor.
5. The average measurement was not performed when the peak measured data under the limit of average detection. If the readings given are average, peak measurement should also be supplied.

Product : Vehicle device wireless audio device  
 Test Item : General Radiated Emission  
 Test Site : No.3 OATS  
 Test Mode : Mode 1: Transmitter (88.1 MHz)

Frequency MHz	Correct Factor dB	Reading Level dBuV	Measurement Level dBuV/m	Margin dB	Limit dBuV/m
<b>Horizontal</b>					
133.026	11.801	24.510	36.311	-7.209	43.520
195.230	8.484	24.350	32.834	-10.686	43.520
249.659	12.210	23.517	35.727	-10.293	46.020
307.976	12.707	23.658	36.366	-9.654	46.020
341.022	13.513	18.632	32.145	-13.875	46.020
414.890	16.372	19.547	35.920	-10.100	46.020
<b>Vertical</b>					
241.844	11.540	20.362	31.902	-14.118	46.020
249.659	12.221	22.441	34.662	-11.358	46.020
341.022	13.299	17.542	30.841	-15.179	46.020
366.293	15.299	19.413	34.712	-11.308	46.020
434.329	18.011	16.234	34.246	-11.774	46.020
613.166	20.177	14.325	34.502	-11.518	46.020

Note:

1. The reading levels below 1GHz are quasi-peak values.
2. "■" means the worst emission level.
3. Measurement Level = Reading Level + Correct Factor.

Product : Vehicle device wireless audio device  
 Test Item : General Radiated Emission  
 Test Site : No.3 OATS  
 Test Mode : Mode 1: Transmitter (98.1 MHz)

Frequency MHz	Correct Factor dB	Reading Level dBuV	Measurement Level dBuV/m	Margin dB	Limit dBuV/m
<b>Horizontal</b>					
196.600	8.592	25.210	33.803	-9.717	43.520
216.000	8.602	24.950	33.551	-9.969	43.520
250.100	12.276	23.680	35.957	-10.063	46.020
484.870	17.250	20.940	38.190	-7.830	46.020
533.467	17.424	20.304	37.728	-8.292	46.020
716.192	19.120	18.307	37.427	-8.593	46.020
<b>Vertical</b>					
135.500	10.968	22.685	33.653	-9.867	43.520
144.000	10.245	23.140	33.385	-10.135	43.520
215.893	9.774	24.689	34.463	-9.057	43.520
300.030	12.667	17.651	30.319	-15.701	46.020
449.880	17.640	21.884	39.524	-6.496	46.020
700.641	19.155	14.380	33.536	-12.484	46.020

Note:

1. The reading levels below 1GHz are quasi-peak values.
2. "█" means the worst emission level.
3. Measurement Level = Reading Level + Correct Factor.

Product : Vehicle device wireless audio device  
 Test Item : General Radiated Emission  
 Test Site : No.3 OATS  
 Test Mode : Mode 1: Transmitter (107.5 MHz)

Frequency MHz	Correct Factor dB	Reading Level dBuV	Measurement Level dBuV/m	Margin dB	Limit dBuV/m
<b>Horizontal</b>					
132.000	11.992	20.847	32.839	-10.681	43.520
196.600	8.592	23.335	31.928	-11.592	43.520
459.599	17.256	17.625	34.881	-11.139	46.020
533.467	17.424	21.664	39.088	-6.932	46.020
665.651	19.232	18.634	37.866	-8.154	46.020
716.192	19.120	14.661	33.781	-12.239	46.020
<b>Vertical</b>					
144.000	10.245	20.685	30.930	-12.590	43.520
158.297	9.142	19.642	28.784	-14.736	43.520
284.145	12.767	16.790	29.557	-16.463	46.020
300.030	12.667	18.240	30.908	-15.112	46.020
434.329	18.011	17.569	35.581	-10.439	46.020
700.641	19.155	13.648	32.804	-13.216	46.020

Note:

1. The reading levels below 1GHz are quasi-peak values.
2. "■" means the worst emission level.
3. Measurement Level = Reading Level + Correct Factor.

Product : Vehicle device wireless audio device  
 Test Item : Harmonic Radiated Emission  
 Test Site : No.3 OATS  
 Test Mode : Mode 1: Transmitter (88.1 MHz)

Frequency MHz	Correct Factor dB	Reading Level dBuV	Measurement Level dBuV/m	Margin dB	Limit dBuV/m
<b>Horizontal</b>					
176.200	9.721	19.819	29.540	-13.980	43.520
264.300	14.249	12.261	26.510	-19.510	46.020
352.400	14.943	8.606	23.549	-22.471	46.020
440.500	17.590	2.827	20.417	-25.603	46.020
528.600	18.638	2.003	20.641	-25.379	46.020
616.700	21.047	-1.011	20.036	-25.984	46.020
704.800	20.578	-0.542	20.036	-25.984	46.020
792.900	22.159	-2.045	20.114	-25.906	46.020
881.000	22.133	-1.435	20.698	-25.322	46.020
<b>Vertical</b>					
176.200	9.652	20.855	30.507	-13.013	43.520
264.300	14.501	13.136	27.638	-18.382	46.020
352.400	15.397	9.965	25.362	-20.658	46.020
440.500	18.934	2.123	21.057	-24.963	46.020
528.600	18.993	1.477	20.471	-25.549	46.020
616.700	21.578	-0.893	20.685	-25.335	46.020
704.800	20.945	-0.294	20.651	-25.369	46.020
792.900	22.010	-1.622	20.388	-25.632	46.020
881.000	22.701	-2.697	20.004	-26.016	46.020

Note:

1. The reading levels below 1GHz are quasi-peak values.
2. "█" means the worst emission level.
3. Measurement Level = Reading Level + Correct Factor.

Product : Vehicle device wireless audio device  
 Test Item : Harmonic Radiated Emission  
 Test Site : No.3 OATS  
 Test Mode : Mode 1: Transmitter (98.1 MHz)

Frequency MHz	Correct Factor dB	Reading Level dBuV	Measurement Level dBuV/m	Margin dB	Limit dBuV/m
<b>Horizontal</b>					
196.200	9.442	21.215	30.657	-12.863	43.520
294.300	13.915	13.726	27.641	-18.379	46.020
392.400	16.065	7.612	23.677	-22.343	46.020
490.500	18.314	2.694	21.007	-25.013	46.020
588.600	20.066	0.048	20.114	-25.906	46.020
686.700	21.020	-0.924	20.096	-25.924	46.020
784.800	21.549	-1.066	20.483	-25.537	46.020
882.900	22.273	-1.765	20.507	-25.513	46.020
981.000	23.432	-3.400	20.032	-33.938	53.970
<b>Vertical</b>					
196.200	9.430	21.617	31.047	-12.473	43.520
294.300	13.808	13.857	27.665	-18.355	46.020
392.400	17.398	6.296	23.694	-22.326	46.020
490.500	18.314	2.682	20.995	-25.025	46.020
588.600	21.842	-1.218	20.624	-25.396	46.020
686.700	20.321	0.310	20.631	-25.389	46.020
784.800	22.184	-2.116	20.069	-25.951	46.020
882.900	22.745	-2.143	20.601	-25.419	46.020
981.000	22.832	-2.758	20.074	-33.896	53.970

Note:

1. The reading levels below 1GHz are quasi-peak values.
2. "■" means the worst emission level.
3. Measurement Level = Reading Level + Correct Factor.

Product : Vehicle device wireless audio device  
 Test Item : Harmonic Radiated Emission  
 Test Site : No.3 OATS  
 Test Mode : Mode 1: Transmitter (107.5 MHz)

Frequency MHz	Correct Factor dB	Reading Level dBuV	Measurement Level dBuV/m	Margin dB	Limit dBuV/m
<b>Horizontal</b>					
215.000	9.364	22.532	31.896	-11.624	43.520
322.500	13.903	13.751	27.654	-18.366	46.020
430.000	17.661	5.375	23.036	-22.984	46.020
537.500	19.163	1.522	20.684	-25.336	46.020
645.000	20.932	-0.601	20.331	-25.689	46.020
752.500	21.234	-0.863	20.371	-25.649	46.020
860.000	22.330	-2.246	20.084	-25.936	46.020
967.500	23.443	-2.781	20.662	-33.308	53.970
<b>Vertical</b>					
215.000	10.690	19.367	30.057	-13.463	43.520
322.500	14.348	12.606	26.954	-19.066	46.020
430.000	19.243	3.395	22.637	-23.383	46.020
537.500	19.799	0.596	20.394	-25.626	46.020
645.000	20.272	0.697	20.969	-25.051	46.020
752.500	23.200	-3.053	20.147	-25.873	46.020
860.000	21.903	-1.542	20.361	-25.659	46.020
967.500	22.943	-2.799	20.144	-33.826	53.970

Note:

1. The reading levels below 1GHz are quasi-peak values.
2. "█" means the worst emission level.
3. Measurement Level = Reading Level + Correct Factor.

Product : Vehicle device wireless audio device  
 Test Item : Harmonic Radiated Emission  
 Test Site : No.3 OATS  
 Test Mode : Mode 1: Transmitter (107.5 MHz)

Frequency MHz	Correct Factor dB	Reading Level dBuV	Measurement Level dBuV/m	Margin dB	Limit dBuV/m
<b>Horizontal</b>					
<b>Peak Detector:</b>					
1075.000	-5.588	40.903	35.315	-38.685	74.000
<b>Average Detector:</b>					
--					
<b>Vertical</b>					
<b>Peak Detector:</b>					
1075.000	-5.588	41.733	36.145	-37.855	74.000
<b>Average Detector:</b>					
--					

Note:

1. The reading levels below 1GHz and above 1GHz are quasi-peak values and peak/average values, respectively.
2. Receiver setting (Peak Detector) : RBW:1MHz; VBW:1MHz; Span:100MHz °
3. Receiver setting (AVG Detector) : RBW:1MHz; VBW:30Hz; Span:20MHz °
4. Emission Level = Reading Level + Correct Factor.
5. The average measurement was not performed when the peak measured data under the limit of average detection. If the readings given are average, peak measurement should also be supplied.

#### 4. Occupied Bandwidth

##### 4.1. Test Equipment

The following test equipments are used during the radiated emission tests:

	Equipment	Manufacturer	Model No./Serial No.	Last Cal.
X	Spectrum Analyzer	Agilent	E4407B/US39440758	May, 2006

- Note: 1. All instruments are calibrated every one year.  
 2. The test instruments marked by “X” are used to measure the final test results.

##### 4.2. Test Setup

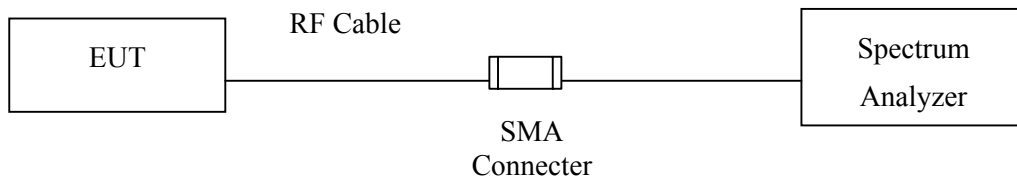

##### 4.3. Limits

FCC Part 15 Subpart C Paragraph 15.239 Limits	
Frequency MHz	Occupied Bandwidth
	kHz
88-108	200

##### 4.4. Uncertainty

± 150Hz

**4.5. Test Result of Occupied Bandwidth**

Product : Vehicle device wireless audio device  
 Test Item : Occupied Bandwidth (modulation)  
 Test Site : No.3 OATS  
 Test Mode : Mode 1: Transmitter

Channel No.	Frequency (MHz)	Measurement Level (kHz)	Required Limit (kHz)	Result
1	88.1	91.5515	200	Pass
51	98.1	116.5043	200	Pass
98	107.5	77.3087	200	Pass

**Channel 1:**

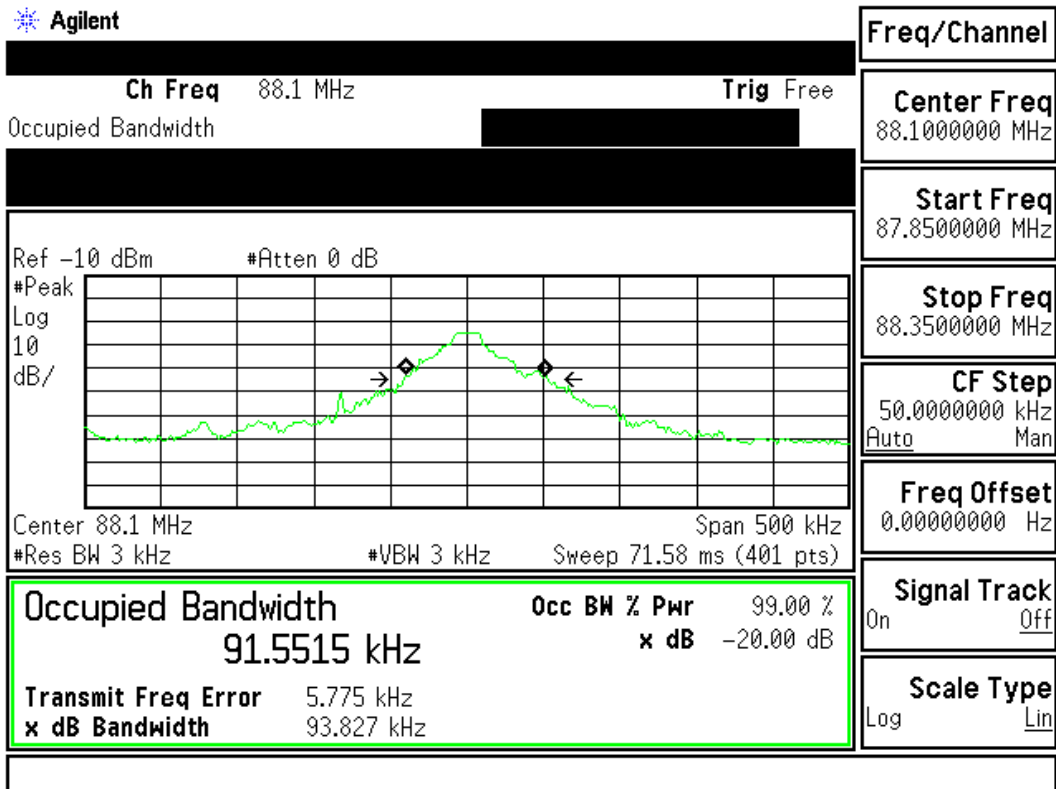

**Channel 51**

Agilent

Ch Freq 98.1 MHz Trig Free  
 Occupied Bandwidth

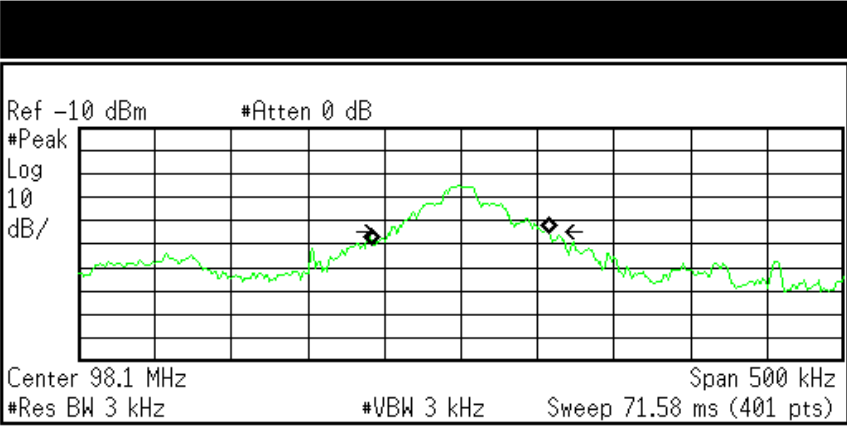

**Occupied Bandwidth** 116.5043 kHz  
 Occ BW % Pwr 99.00 %  
 x dB -20.00 dB  
 Transmit Freq Error -419.380 Hz  
 x dB Bandwidth 103.181 kHz

<b>Freq/Channel</b>
<b>Center Freq</b> 98.1000000 MHz
<b>Start Freq</b> 97.8500000 MHz
<b>Stop Freq</b> 98.3500000 MHz
<b>CF Step</b> 50.0000000 kHz Auto Man
<b>Freq Offset</b> 0.00000000 Hz
<b>Signal Track</b> On Off
<b>Scale Type</b> Log Lin

**Channel 98:**

Agilent

Ch Freq 107.55 MHz Trig Free  
 Occupied Bandwidth

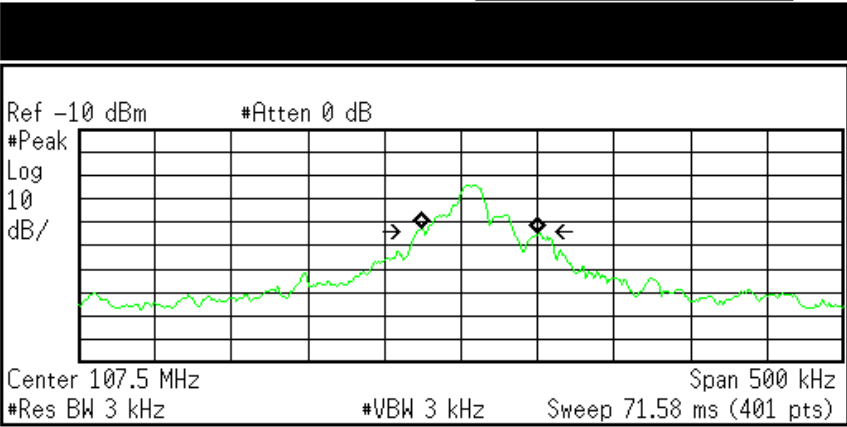

**Occupied Bandwidth** 77.3087 kHz  
 Occ BW % Pwr 99.00 %  
 x dB -20.00 dB  
 Transmit Freq Error 11.912 kHz  
 x dB Bandwidth 80.388 kHz

<b>Marker</b>
<b>Select Marker</b> 1 2 3 4
<b>Normal</b>
<b>Delta</b>
<b>Delta Pair</b> (Tracking Ref) Ref Delta
<b>Span Pair</b> Span Center
<b>Off</b>
<b>More</b> 1 of 2

## 5. Band Edge

### 5.1. Test Equipment

The following test equipments are used during the band edge tests:

Equipment	Manufacturer	Model No./Serial No.	Last Cal.
X Test Receiver	R & S	ESI 26 / 838786/004	May, 2006
X Spectrum Analyzer	Agilent	E4407B / US39440758	May, 2006
X Bilog Antenna	SCHAFFNER	CBL6112B / 2697	May, 2006
X Horn Antenna	Schwarzbeck	BBHA9120D / 305, 306	July, 2006
X Horn Antenna	Schwarzbeck	BBHA9170 / 208, 209	July, 2006
X Pre-Amplifier	QTK	QTK-AMP-01 / 0001	July, 2006
X Pre-Amplifier	QTK	QTK-AMP-03 / 0003	May, 2006
X Pre-Amplifier	HP	8449B / 3008A01123	July, 2006

OATS No.3

- Note:
1. All equipments are calibrated every one year.
  2. The test equipments marked by “X” are used to measure the final test results.

### 5.2. Test Setup

#### RF Radiated Measurement:

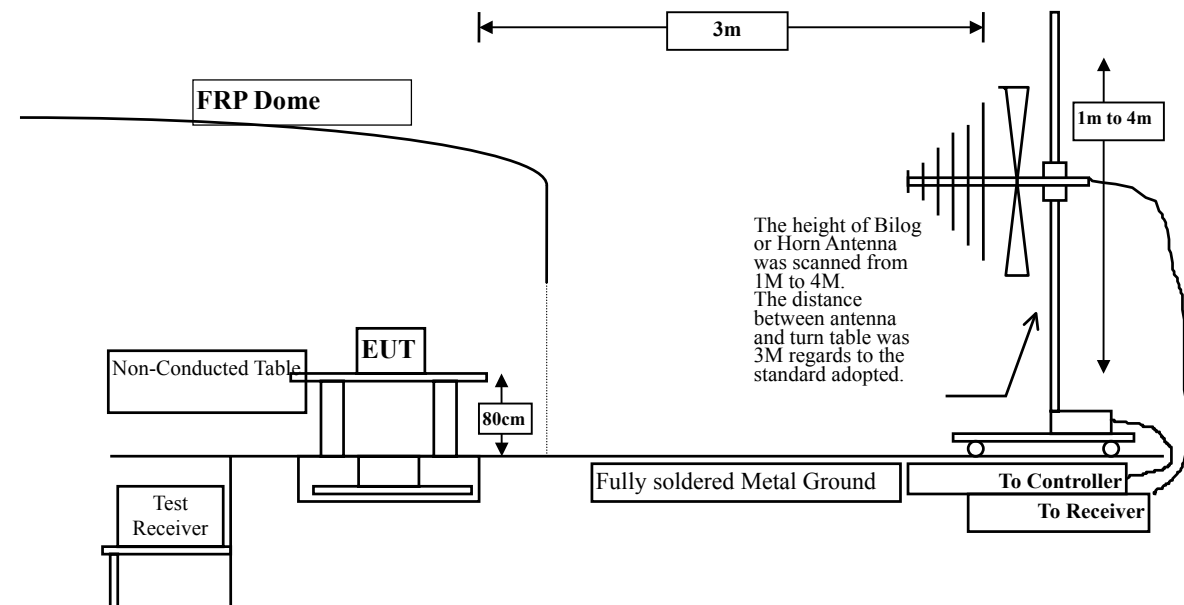

### 5.3. Limits

The 200 kHz band shall lie wholly within the frequency range of 88–108 MHz. The field strength of any emissions appearing outside of this band shall not exceed the general radiated emission limits shown in Section 15.209. Attenuation below the general limits specified in Section 15.209(a) is not required. In addition, radiated emissions which fall in the restricted bands, as defined in Section 15.205(a), must also comply with the radiated emission limits specified in Section 15.209(a) (see Section 15.205(c)).

### 5.4. Test Procedure

The EUT and its simulators are placed on a turn table which is 0.8 meter above ground. The turn table can rotate 360 degrees to determine the position of the maximum emission level. The EUT was positioned such that the distance from antenna to the EUT was 3 meters.

The antenna can move up and down between 1 meter and 4 meters to find out the maximum emission level.

Both horizontal and vertical polarization of the antenna are set on measurement. In order to find the maximum emission, all of the interface cables must be manipulated according to ANSI C63.4: 2003 on radiated measurement.

The bandwidth below 30MHz setting on the field strength meter (R&S Test Receiver ESI 26 ) is 9 kHz, 30MHz to 1GHz is 120 kHz and above 1GHz are 1 MHz.

### 5.5. Uncertainty

± 3.8 dB below 1GHz

**5.6. Test Result of Band Edge**

Product : Vehicle device wireless audio device  
 Test Item : Band Edge  
 Test Site : No.3 OATS  
 Test Mode : Mode 1: Transmitter (88.1 MHz)

**RF Radiated Measurement (Horizontal):**

Channel No.	Frequency (MHz)	Correct Factor (dB)	Reading Level (dBuV)	Emission Level (dBuV/m)	Quasi-Peak Limit (dBuV/m)	Result
1 (Quasi-Peak)	74.900	10.877	18.060	28.937	40.00	Pass

**Figure Channel 1: Horizontal (Quasi-Peak)**

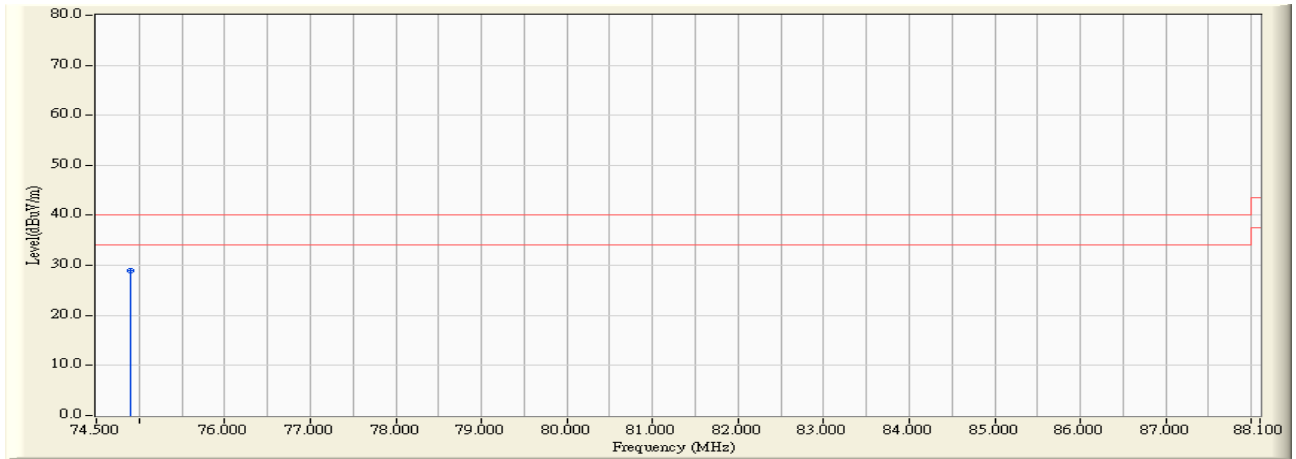

Note: RBW=120KHz

Product : Vehicle device wireless audio device  
 Test Item : Band Edge  
 Test Site : No.3 OATS  
 Test Mode : Mode 1: Transmitter (88.1 MHz)

**RF Radiated Measurement (Vertical):**

Channel No.	Frequency (MHz)	Correct Factor (dB)	Reading Level (dBuV)	Emission Level (dBuV/m)	Quasi-Peak Limit (dBuV/m)	Result
1 (Quasi-Peak)	75.140	15.508	20.280	35.788	40.00	Pass

**Figure Channel 1: Vertical (Quasi-Peak)**

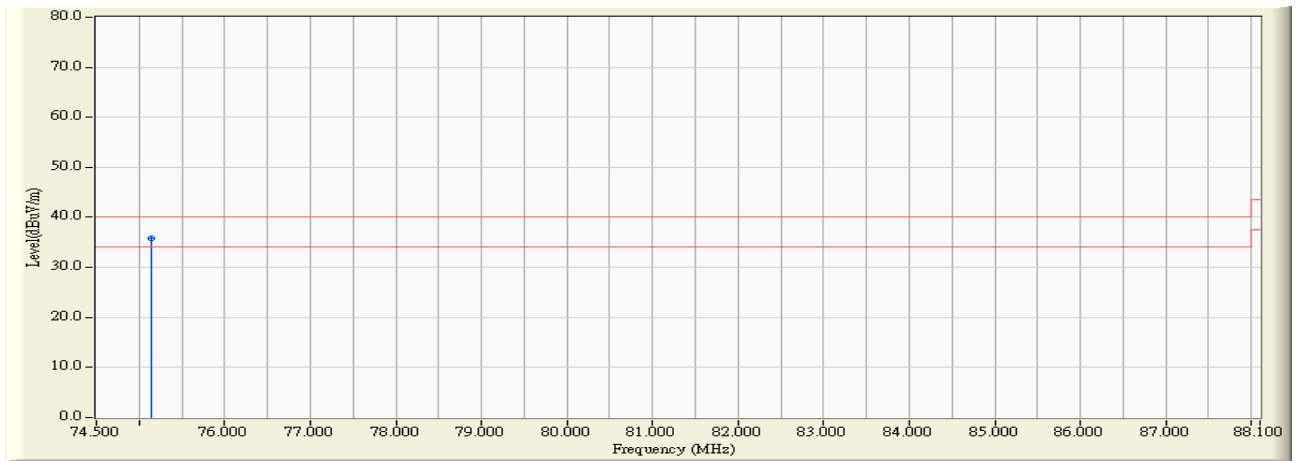

Note: RBW=120KHz

Product : Vehicle device wireless audio device  
 Test Item : Band Edge  
 Test Site : No.3 OATS  
 Test Mode : Mode 1: Transmitter (107.5 MHz)

**RF Radiated Measurement (Horizontal):**

Channel No.	Frequency (MHz)	Correct Factor (dB)	Reading Level (dBuV)	Emission Level (dBuV/m)	Quasi-Peak Limit (dBuV/m)	Result
98 (Quasi-Peak)	118.140	15.515	17.880	33.395	43.520	Pass

**Figure Channel 98:**

**Horizontal (Quasi-Peak)**

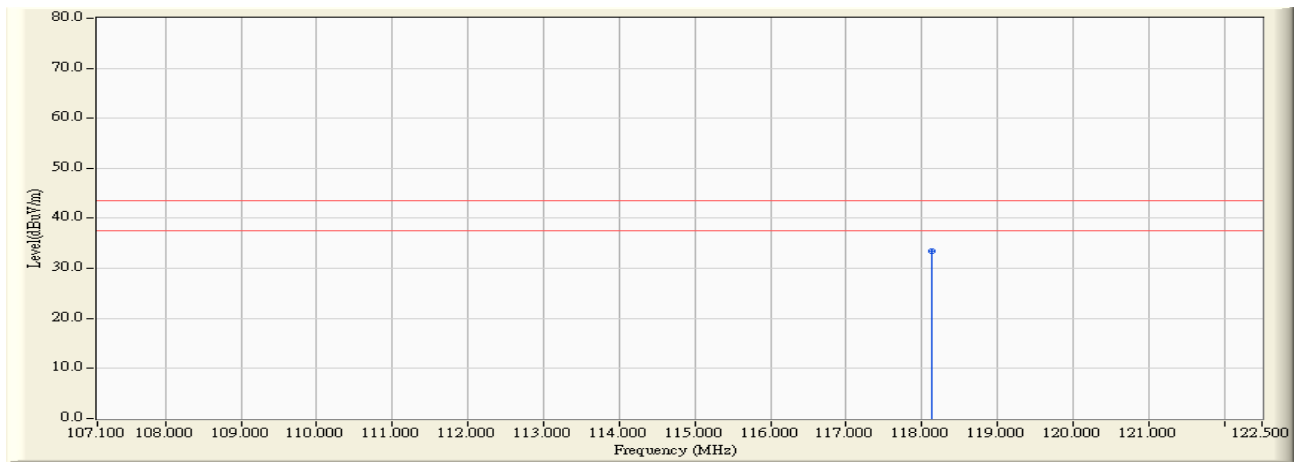

Note: RBW=120KHz

Product : Vehicle device wireless audio device  
 Test Item : Band Edge  
 Test Site : No.3 OATS  
 Test Mode : Mode 1: Transmitter (107.5 MHz)

**RF Radiated Measurement (Vertical):**

Channel No.	Frequency (MHz)	Correct Factor (dB)	Reading Level (dBuV)	Emission Level (dBuV/m)	Quasi-Peak Limit (dBuV/m)	Result
98 (Quasi-Peak)	120.020	19.029	20.220	39.249	43.520	Pass

**Figure Channel 98: Vertical (Quasi-Peak)**

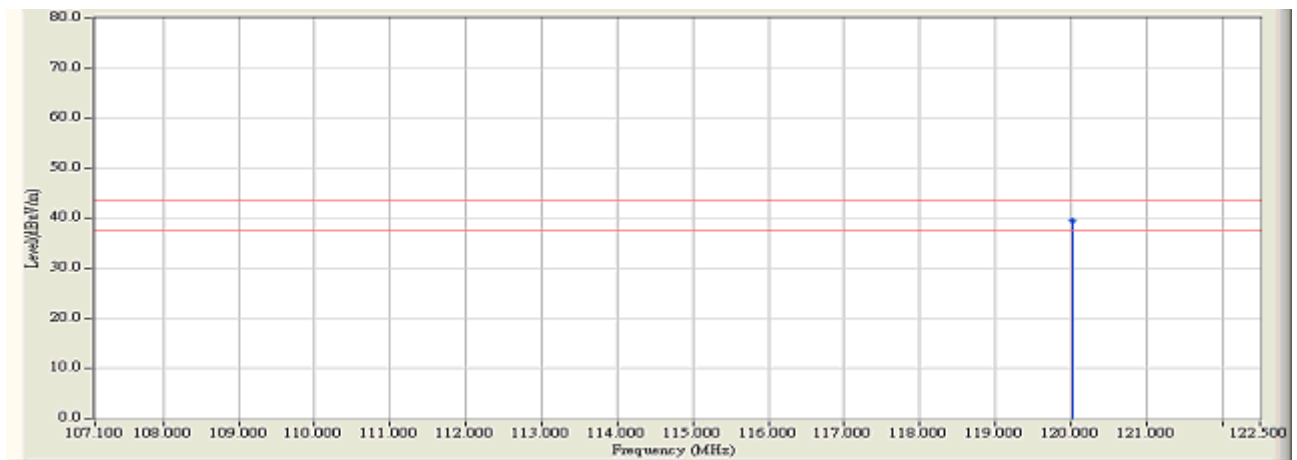

Note: RBW=120KHz

## 6. EMI Reduction Method During Compliance Testing

No modification was made during testing.