

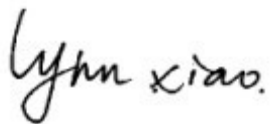
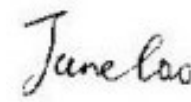
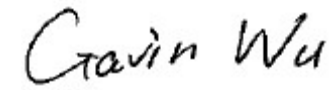

TEST REPORT

Report No.:	EM201300650-4	Application No.:	ZJ00032008
Applicant:	Harman International Industries, Incorporated		
Applicant Address:	8500 Balboa Blvd, Northridge, CA 91329, United States		
Sample Description:	Active speaker system with wireless streaming		
Model:	AUTHENTICS L16		
Adding Model:	/		
FCC ID:	APIAUTHENL16		
Test Specification:	FCC Part 15, Subpart C (Section 15.247)		
Test Date:	2013-08-08 to 2013-09-26		
Issue Date:	2013-09-26		
Test Result:	PASS		
Prepared By:	Reviewed By:	Approved By:	
Lynn Xiao / Test Engineer	Jane Cao / Technical Assistance	Gavin Wu / Manager	
			
Date: 2013-09-26	Date: 2013-09-26	Date: 2013-09-26	
Other Aspects:			
/			
Abbreviations: ok / P = passed; fail / F = failed; n.a. / N = not applicable			
The test result in this test report refers exclusively to the presented test sample. This report shall not be reproduced except in full, without the written approval of GRGT.			

GRG Metrology and Test Co., Ltd.

Address: 163, Pingyun Road, West of Huangpu Avenue, Guangzhou, Guangdong, P.R. China

Tel: +86-20-38699960

Fax: +86-20-38695185

Email: cert-center@grg.net.cn

<http://www.grgtest.com>

Ver.: 1.0 / 01.Jan.2011

DIRECTIONS OF TEST

1. This station carries out test task according to the national regulation of verifications which can be traced to National Primary Standards and BIPM.
2. The test report merely corresponds to the test sample. It is not permitted to copy extracts of these test result without the written permission of the test laboratory.
3. If there is any objection concerning the test, the client should inform the laboratory within 15 days from the date of receiving the test report.

Table of Contents

TABLE OF CONTENTS.....	3
1. TEST RESULT SUMMARY	5
2. GENERAL DESCRIPTION OF EUT.....	6
2.1 APPLICANT	6
2.2 MANUFACTURER	6
2.3 BASIC DESCRIPTION OF EQUIPMENT UNDER TEST	6
3. LABORATORY AND ACCREDITATIONS	7
3.1 LABORATORY	7
3.2 ACCREDITATIONS.....	7
3.3 MEASUREMENT UNCERTAINTY	7
3.4 LIST OF USED TEST EQUIPMENT AT GRGT	8
4. ANTENNA REQUIREMENT	9
5. CONDUCTED EMISSION MEASUREMENT	10
5.1 LIMITS.....	10
5.2 TEST PROCEDURES.....	10
5.3 TEST SETUP	11
5.4 TEST RESULTS	12
6. RADIATED ELECTROMAGNETIC DISTURBANCE.....	14
6.1 LIMITS.....	14
6.2 TEST PROCEDURES.....	14
6.3 TEST SETUP	15
6.4 TEST RESULTS	17
7. 6DB BANDWIDTH TESTING	29
7.1 LIMITS.....	29
7.2 TEST PROCEDURES.....	29
7.3 TEST SETUP	29
7.4 TEST RESULTS	29
8. MAXIMUM PEAK OUTPUT POWER.....	34
8.1 LIMITS.....	34
8.2 TEST PROCEDURES.....	34
8.3 TEST SETUP	34
8.4 TEST RESULTS	34
9. POWER SPECTRAL DENSITY.....	38
9.1 LIMITS.....	38
9.2 TEST PROCEDURES.....	38
9.3 TEST SETUP	38
9.4 TEST RESULTS	39
10. EMISSIONS IN NON-RESTRICTED FREQUENCY BANDS.....	43
10.1 LIMITS.....	43
10.2 TEST PROCEDURES.....	43
10.3 TEST SETUP	43
10.4 TEST RESULTS	43
11. EMISSIONS IN RESTRICTED FREQUENCY BANDS.....	56
11.1 LIMITS.....	56
11.2 TEST PROCEDURES.....	56
11.3 TEST SETUP	57
11.4 TEST RESULTS	58
12. BAND-EDGE MEASUREMENTS.....	74
12.1 LIMITS.....	74
12.2 TEST PROCEDURES.....	74

12.3 TEST SETUP 74
12.4 TEST RESULTS 74

1. TEST RESULT SUMMARY

Section B of FCC Part 15.247:2012			
Standard	Item	Limit / Severity	Result
FCC Part 15,Subpart C (15.247)	Antenna Requirement	§15.203	PASS
	Conducted Emissions	§15.207 (a)	PASS
	Radiated Electromagnetic Disturbance	§15.247(d)	PASS
	6 Db Bandwidth	§15.247 (a)(2)	PASS
	Maximum Peak Output Power	§15.247(b)(3)	PASS
	Power Spectral Density	§15.247(e)	PASS
	Emissions In Non-Rest ricted Frequency Bands	§15.247(d)	PASS
	Emissions In Restricted Frequency Bands	§15.205	PASS
	Band-Edge Measurements	§15.247(d)	PASS

2. GENERAL DESCRIPTION OF EUT

2.1 APPLICANT

Name: Harman International Industries, Incorporated
Address: 8500 Balboa Blvd, Northridge, CA 91329, United States

2.2 MANUFACTURER

Name: Harman International Industries, Incorporated
Address: 8500 Balboa Blvd, Northridge, CA 91329, United States

2.3 BASIC DESCRIPTION OF EQUIPMENT UNDER TEST

Equipment: Active speaker system with wireless streaming
Model No.: AUTHENTICS L16
Adding Model /
Trade Name: JBL
Power supply AC 100-240V,50/60Hz
Frequency Range 2400MHZ~ 2483.5MHz
Max Antenna gain: 4.2dBi, 4.13dBi,
Type of emission WIFI
Modulation type DSSS (802.11b) OFDM (802.11g)
Note: Pretest the two antenna port (con1 and con2). Found that con1 is worst and the antenna gain of this port is 4.2dBi. So we record con1 port data.

3. LABORATORY AND ACCREDITATIONS

3.1 LABORATORY

The tests and measurements refer to this report were performed by Guangzhou GRG Metrology and Test CO., LTD.

Add. : 163 Pingyun Rd, West of Huangpu Ave, Guangzhou, 510656, P. R. China

Telephone: +86-20-38699959, 38699960, 38699961

Fax : +86-20-38695185

3.2 ACCREDITATIONS

Our laboratories are accredited and approved by the following approval agencies according to ISO/IEC 17025.

USA	FCC Listed Lab (No. 688188)
China	CNAS (No.L0446)
China	DILAC (No.DL175)
Canada	Registration No.:8355A-1

3.3 MEASUREMENT UNCERTAINTY

Where relevant, the following measurement uncertainty levels have been estimated for tests performed on the EUT as specified in CISPR 16-4-2:

Measurement		Frequency	Uncertainty
Radiated Emission	Horizontal	30MHz~1000MHz	4.2dB
		1GHz~26.5GHz	4.2dB
	Vertical	30MHz~1000MHz	4.4dB
		1GHz~26.5GHz	4.4dB
Conducted Emission		9kHz~30MHz	3.1 dB

This uncertainty represents an expanded uncertainty factor of $k=2$.

3.4 LIST OF USED TEST EQUIPMENT AT GRGT

Name of Equipment	Manufacturer	Model	Serial Number	Calibration Due
Conducted Emissions				
EMI Receiver	R&S	ESU40	100529	2014-01-24
L.I.S.N	SCHWARZBECK	NSLK 8127	8127450	2014-08-06
Spurious Emissions at Antenna Port				
Receiver	R&S	ESU40	100106	2014-01-24
Restricted Bands				
Receiver	R&S	ESU40	100106	2014-01-24
Spurious Emissions				
Receiver	R&S	ESU40	100106	2014-01-24
Signal Generator	R&S	SML03	103002	2013-11-14
Biconical Log-periodic Antenna	ETS.LINDGREN	3142C	00075971	2014-05-26
Horn antenna	SCHWARZBECK	BBHA9120D	D752	2013-10-14
6 dB Bandwidth				
Receiver	R&S	ESU40	100106	2014-01-24
Maximum Peak Output Power				
Receiver	R&S	ESU40	100106	2014-01-24
100kHz Bandwidth of Frequency Band Edge				
Receiver	R&S	ESU40	100106	2014-01-24
Power Spectral Density				
Receiver	R&S	ESU40	100106	2014-01-24

NOTE: The calibration interval of the above test instruments is 12 months.

4. ANTENNA REQUIREMENT

The EUT has two antennas. The antenna is a PCB antenna.

The max gain of antenna 1 is 4.2dBi and the max gain of antenna 2 is 4.13dBi .which accordance 15.203.is considered sufficient to comply with the provisions of this section

5. CONDUCTED EMISSION MEASUREMENT

5.1 LIMITS

Frequency range	Limits (dB μ V)	
	Quasi-peak	Average
150kHz ~ 0.5MHz	66~56	56~46
0.5 MHz ~ 5 MHz	56	46
5 MHz ~ 30 MHz	60	50

NOTE: (1) The lower limit shall apply at the transition frequencies.

(2) The limit decreases in line with the logarithm of the frequency in the range of 150 kHz to 0.5MHz.

5.2 TEST PROCEDURES

Procedure of Preliminary Test

Test procedures follow ANSI C63.4:2009.

For measurement of the disturbance voltage the equipment under test (EUT) is connected to the power supply mains and any other extended network via one or more artificial network(s). An EUT, whether intended to be grounded or not, and which is to be used on a table is configured as follows:

- Either the bottom or the rear of the EUT shall be at a controlled distance of 40 cm from a reference ground plane. This ground plane is normally the wall or floor of a shielded room. It may also be a grounded metal plane of at least 2 m by 2 m. This is physically accomplished as follows:

- 1) place the EUT on a table of non-conducting material which is at least 80 cm high. Place the EUT so that it is 40 cm from the wall of the shielded room, or

- 2) place the EUT on a table of non-conducting material which is 40 cm high so that the bottom of the EUT is 40 cm above the ground plane;

- All other conductive surfaces of the EUT shall be at least 80 cm from the reference ground plane;

- The EUT are placed on the floor that one side of the housings is 40 cm from the vertical reference ground plane and other metallic parts;

- Interconnecting cables that hang closer than 40 cm to the ground plane shall be folded back and forth forming a bundle 30 cm to 40 cm long, hanging approximately in the middle between the ground plane and the table.

- I/O cables that are connected to a peripheral shall be bundled in the centre. The end of the cable may be terminated if required using correct terminating impedance. The total length shall not exceed 1 m.

The test mode(s) described in Item 2.4 were scanned during the preliminary test. After the preliminary scan, we found the test mode described in Item 2.4 producing the highest emission level. The EUT configuration and cable configuration of the above highest emission levels were recorded for reference of the final test.

Procedure of Final Test

EUT and support equipment were set up on the test bench as per the configuration with highest emission level in the preliminary test. A scan was taken on both power lines,

recording at least the six highest emissions. Emission frequency and amplitude were recorded into a computer in which correction factors were used to calculate the emission level and compare reading to the applicable limit. The test data of the worst-case condition(s) was recorded.

5.3 TEST SETUP

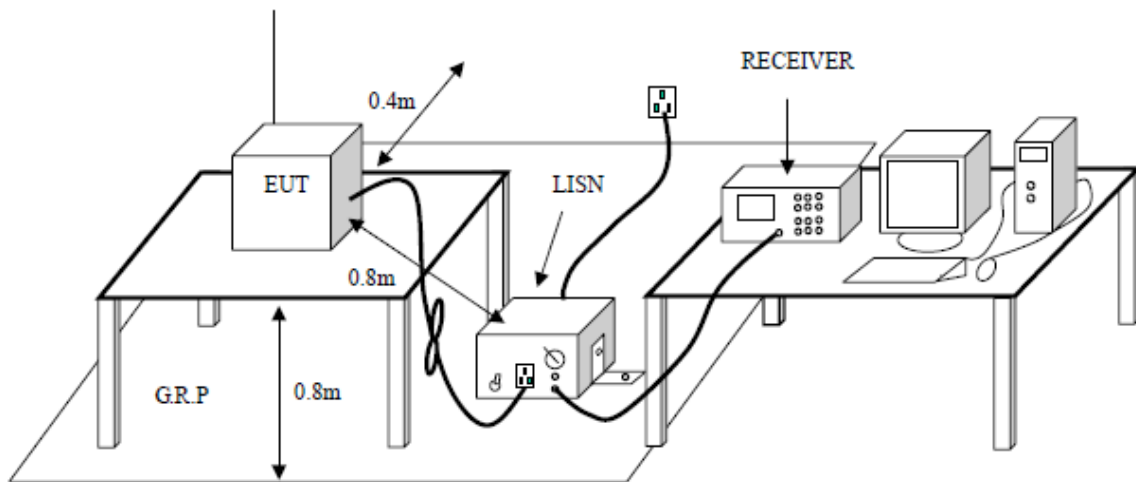

5.4 TEST RESULTS

Project No.:	ZJ00032008	Probe:	L1
Standard:	(CE)FCC PART 15 class B_QP	Power Source:	
Test item:	Conduction Test	Date:	2013-08-12
Temp./Hum.(%RH):	21/56%RH	Time:	19:59:24
EUT:	JBL AUTHENTICS L16	Test Result:	Pass
Model:			
Note:			

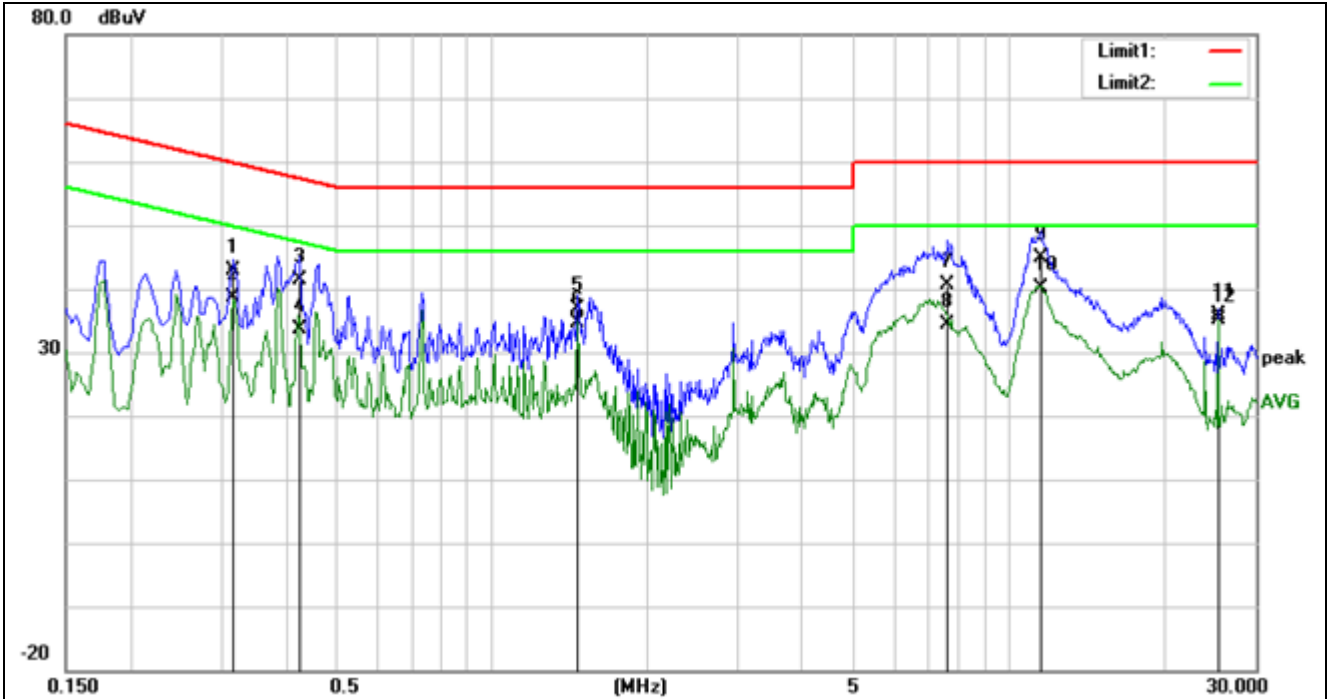

No.	Frequency (MHz)	Reading (dBuV)	Correct Factor(dB)	Result (dBuV)	Limit (dBuV)	Margin (dB)	Remark
1	0.3180	42.78	0.12	42.90	59.76	-16.86	QP
2	0.3180	38.48	0.12	38.60	49.76	-11.16	AVG
3	0.4260	41.18	0.12	41.30	57.33	-16.03	QP
4	0.4260	33.58	0.12	33.70	47.33	-13.63	AVG
5	1.4700	36.76	0.24	37.00	56.00	-19.00	QP
6	1.4700	34.46	0.24	34.70	46.00	-11.30	AVG
7	7.6460	40.02	0.58	40.60	60.00	-19.40	QP
8	7.6460	33.92	0.58	34.50	50.00	-15.50	AVG
9	11.5140	44.29	0.71	45.00	60.00	-15.00	QP
10	11.5140	39.39	0.71	40.10	50.00	-9.90	AVG
11	25.4020	34.85	1.15	36.00	60.00	-24.00	QP
12	25.4020	33.95	1.15	35.10	50.00	-14.90	AVG

Project No.:	ZJ00032008	Probe:	N
Standard:	(CE)FCC PART 15 class B_QP	Power Source:	
Test item:	Conduction Test	Date:	2013-08-12
Temp./Hum.(%RH):	21/56%RH	Time:	19:55:36
EUT:	JBL AUTHENTICS L16	Test Result:	Pass
Model:			
Note:			

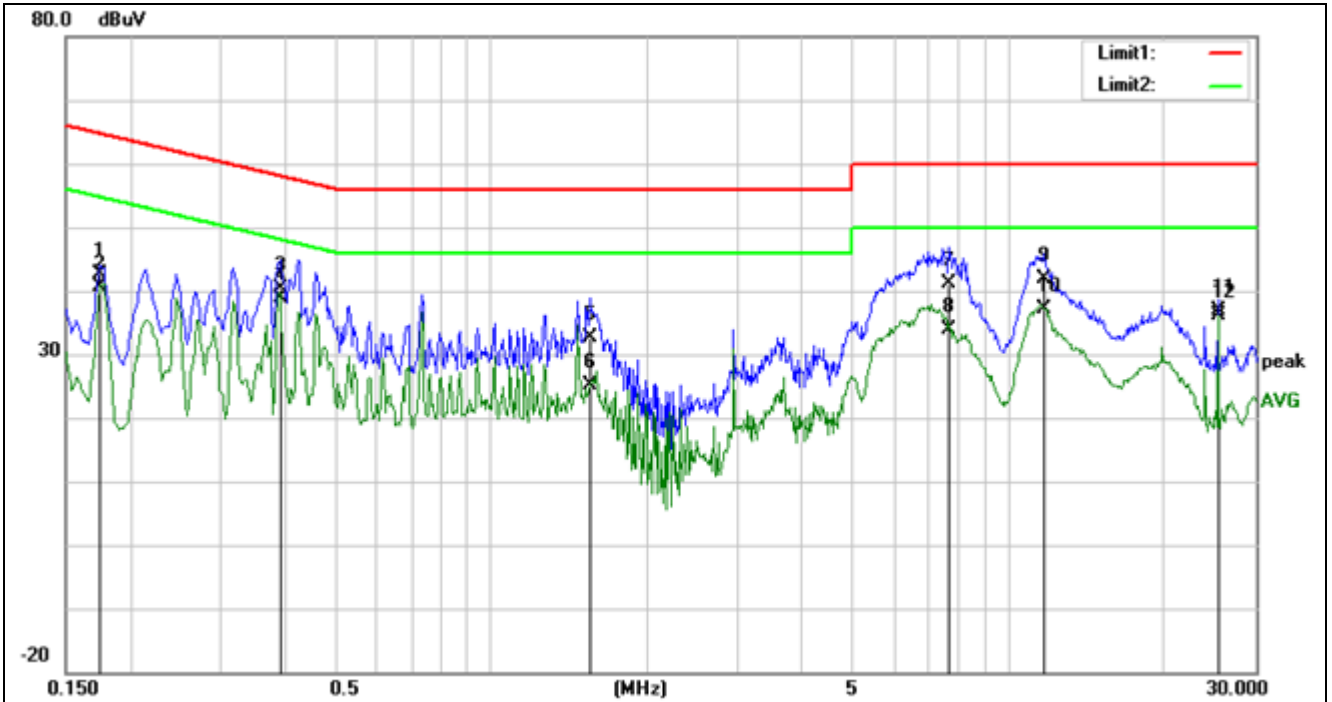

No.	Frequency (MHz)	Reading (dBuV)	Correct Factor(dB)	Result (dBuV)	Limit (dBuV)	Margin (dB)	Remark
1	0.1740	42.58	0.12	42.70	64.76	-22.06	QP
2	0.1740	40.58	0.12	40.70	54.76	-14.06	AVG
3	0.3899	40.28	0.12	40.40	58.06	-17.66	QP
4	0.3899	38.88	0.12	39.00	48.06	-9.06	AVG
5	1.5460	32.36	0.24	32.60	56.00	-23.40	QP
6	1.5460	24.96	0.24	25.20	46.00	-20.80	AVG
7	7.6500	40.62	0.58	41.20	60.00	-18.80	QP
8	7.6500	33.22	0.58	33.80	50.00	-16.20	AVG
9	11.7340	41.04	0.76	41.80	60.00	-18.20	QP
10	11.7340	36.44	0.76	37.20	50.00	-12.80	AVG
11	25.4020	35.85	1.15	37.00	60.00	-23.00	QP
12	25.4020	34.95	1.15	36.10	50.00	-13.90	AVG

6. RADIATED ELECTROMAGNETIC DISTURBANCE

6.1 LIMITS

Frequency (MHz)	Quasi-peak(dB μ V/m)
30 ~ 88	40
88~216	43.5
216 ~ 960	46
Above 960	54

NOTE: (1) The lower limit shall apply at the transition frequencies.

Frequency (GHz)	Quasi-peak(dB μ V/m)
1 ~ 26.5	74
1~ 26.5	54

6.2 TEST PROCEDURES

Test procedures follow ANSI C63.10:2009.

Procedure of Preliminary Test

Radiated emission tests shall be made with the receive or transmit antenna located at a horizontal distance of 3 m plus half of the maximum width of the EUT being tested, measured from the centre of the EUT. The tests shall be performed with the equipment configured as closely as possible to its typical, practical operation. Unless stated otherwise, cables and wiring shall be as specified by the manufacturer and the equipment shall be in its housing (or cabinet) with all covers and access panels in place. Any deviation from normal EUT operating conditions shall be included in the test report.

The EUT (on a non-conductive support structure, where applicable) shall be placed on a remotely operated turntable, to allow the EUT to be rotated. The height of the EUT above the ground plane shall be according to the following requirements.

- Table-top equipment is placed on a non-conductive set-up table with height 0,8 m \pm 0,01 m, ANSI C63.10 specifies the method to determine the impact of the non-conductive set-up table on test results.
- Floor-standing equipment is placed on a non-conductive support, as specified in the applicable product standard. If there are no EUT height placement requirements in the product standard, the EUT shall be placed on a non-conductive support at a height of 5 cm to 15 cm above the ground plane.

Interface cables, loads, and devices should be connected to at least one of each type of the interface ports of the EUT and, where practical, each cable shall be terminated in a device typical for its actual use. Where there are multiple interface ports of the same type, a typical number of these devices shall be connected to devices or loads. It is sufficient to connect only one of the loads, provided that it can be shown, for example by preliminary testing, that the connection of further ports would not significantly increase the level of disturbance (that is, more than 2 dB) or significantly degrade the immunity level.

The test mode(s) described in Item 2.4 were scanned during the preliminary test. After the preliminary scan, we found the test mode described in Item 2.4 producing the highest emission level. The EUT and cable configuration, antenna position, polarization and turntable position of the above highest emission level were recorded for the final test.

Procedure of Final Test

EUT and support equipment were set up on the turntable as per the configuration with highest emission level in the preliminary test. The Analyzer / Receiver scanned from 30MHz to 1000MHz. Emissions were scanned and measured rotating the EUT to 360 degrees, varying cable placement and positioning the antenna 1 to 4 meters above the ground plane, in both the vertical and the horizontal polarization, to maximize the emission reading level. Record at least six highest emissions. Emission frequency, amplitude, antenna position, polarization and turntable position were recorded into a computer in which correction factors were used to calculate the emission level and compare reading to the applicable limit and only QP reading is presented. The test data of the worst-case condition(s) was recorded.

Procedure of Final Test

EUT and support equipment were set up on the test bench as per the configuration with highest emission level in the preliminary test. A scan was taken on both power lines, recording at least the six highest emissions. Emission frequency and amplitude were recorded into a computer in which correction factors were used to calculate the emission level and compare reading to the applicable limit. The test data of the worst-case condition(s) was recorded.

6.3 TEST SETUP

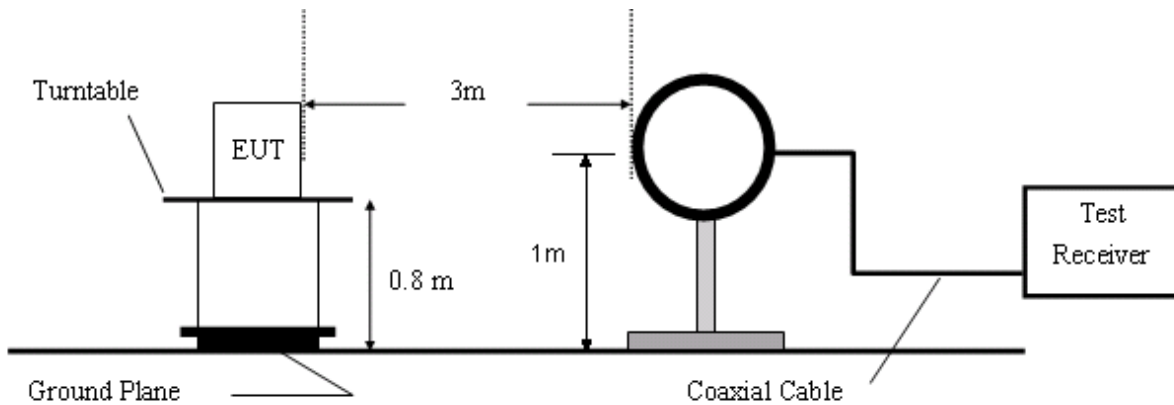

Figure 1. 9KHz to 30MHz radiated emissions test configuration

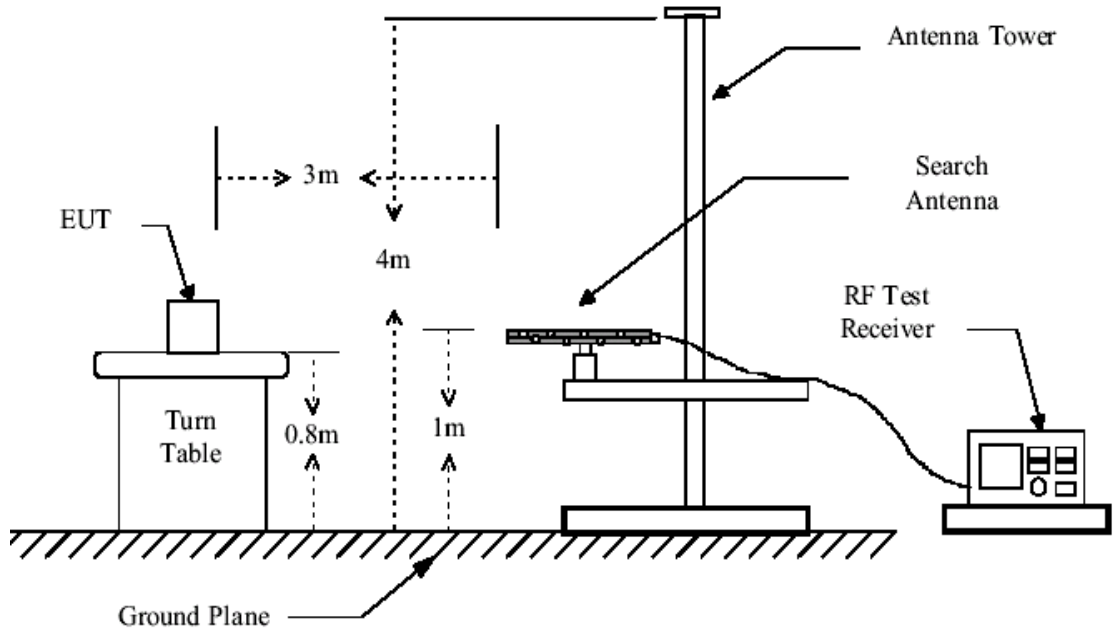

Figure 2. 30MHz to 1GHz radiated emissions test configuration

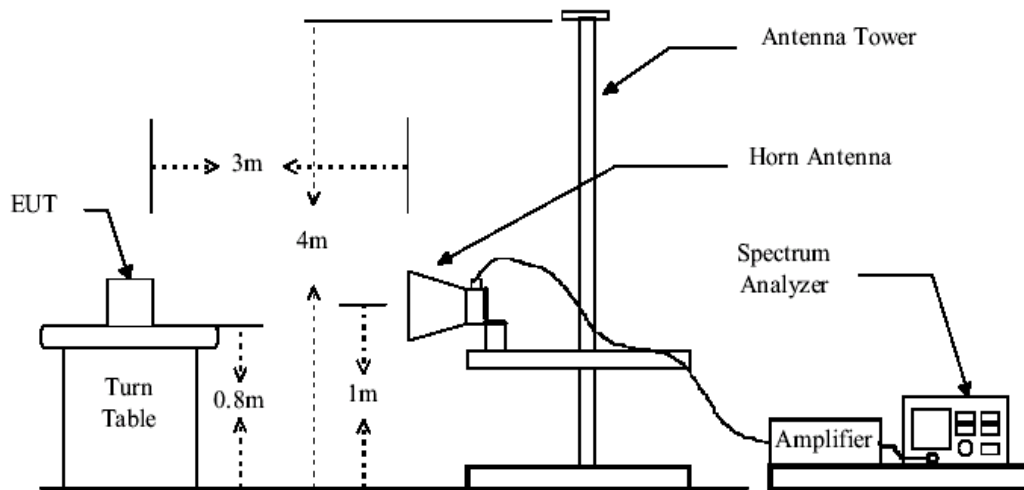
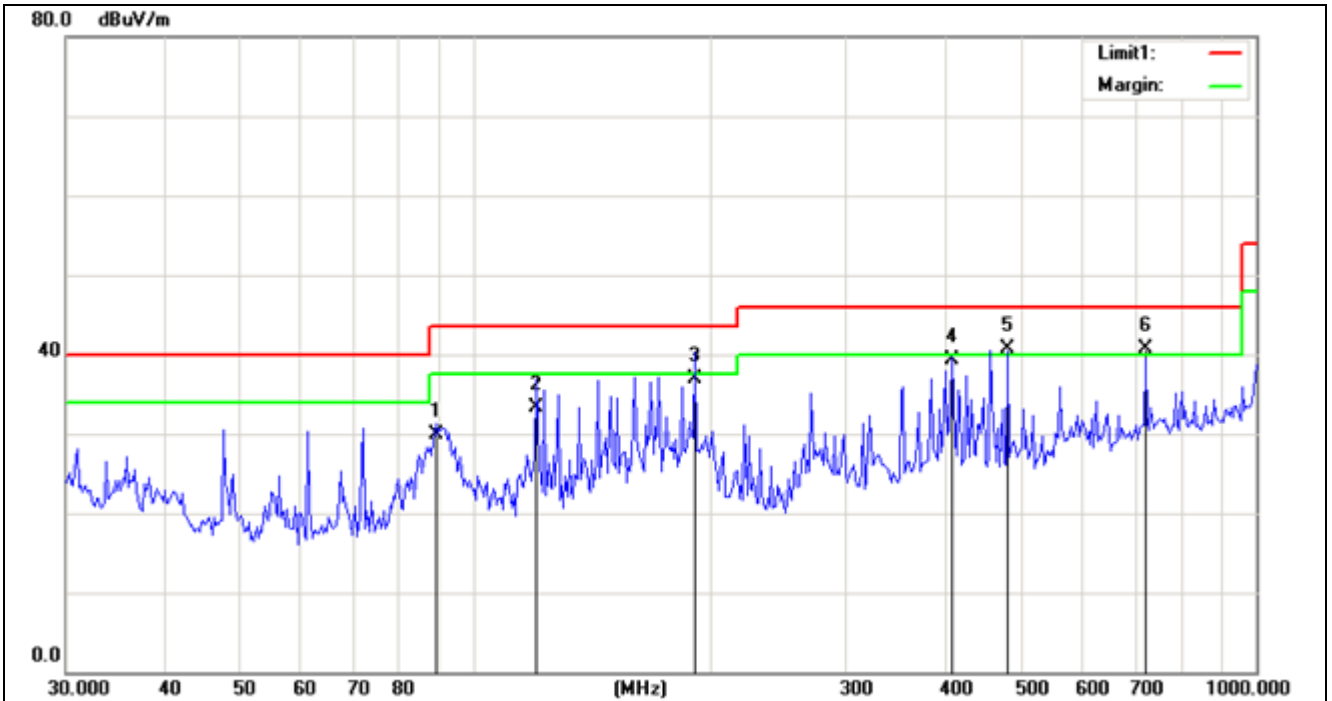

Figure 3. Above 1GHz radiated emissions test configuration

6.4 TEST RESULTS

Project No.:	ZJ00032008	Polarziation:	Vertical
Standard:	(RE)FCC PART 15 class B 3m	Power Source:	
Test item:	Radiation Test	Date:	2013-9-4
Temp./Hum.(%RH):	22.3/73%RH	Time:	15:36:16
EUT:	JBL AUTHENTICS L16	Distance:	3m
Model:	B-2412	Test Result:	Pass
Note:			



No.	Frequency (MHz)	Reading (dBuV/m)	Correct Factor(dB/m)	Result (dBuV/m)	Limit (dBuV/m)	Margin (dB)	Remark
1	89.2443	20.36	9.54	29.90	43.50	-13.60	QP
2	120.2064	24.53	8.87	33.40	43.50	-10.10	QP
3	191.6416	25.45	11.45	36.90	43.50	-6.60	QP
4	409.2218	21.14	18.26	39.40	46.00	-6.60	QP
5	481.6523	20.83	19.97	40.80	46.00	-5.20	QP
6	721.8557	16.46	24.24	40.70	46.00	-5.30	QP

Emission above 1GHz:

No.	Frequency (MHz)	Reading (dBuV/m)	Correct Factor(dB/m)	Result (dBuV/m)	Limit (dBuV/m)	Margin (dB)	Remark
1	1741.223	30.53	18.89	49.42	74.00	-24.58	peak
2	1741.223	13.41	18.89	32.30	54.00	-21.70	AVG
3	1835.663	24.32	19.03	43.35	74.00	-30.65	peak
4	1835.663	7.87	19.03	26.90	54.00	-27.10	AVG
5	2756.891	18.19	24.07	42.26	74.00	-31.74	peak
6	2756.891	6.63	24.07	30.70	54.00	-23.30	AVG
7	8314.181	28.63	23.88	52.51	74.00	-21.49	peak
8	8314.181	15.92	23.88	39.80	54.00	-14.20	AVG
9	9708.665	29.23	25.21	54.44	74.00	-19.56	peak
10	9708.665	14.99	25.21	40.20	54.00	-13.80	AVG
11	11079.578	28.33	24.86	53.19	74.00	-20.81	peak
12	11079.578	15.14	24.86	40.00	54.00	-14.00	AVG

Project No.:	ZJ00032008	Polarization:	Horizontal
Standard:	(RE)FCC PART 15 class B 3m	Power Source:	
Test item:	Radiation Test	Date:	2013-9-4
Temp./Hum.(%RH):	22.3/73%RH	Time:	15:44:25
EUT:	JBL AUTHENTICS L16	Distance:	3m
Model:	B-2412	Test Result:	Pass
Note:			

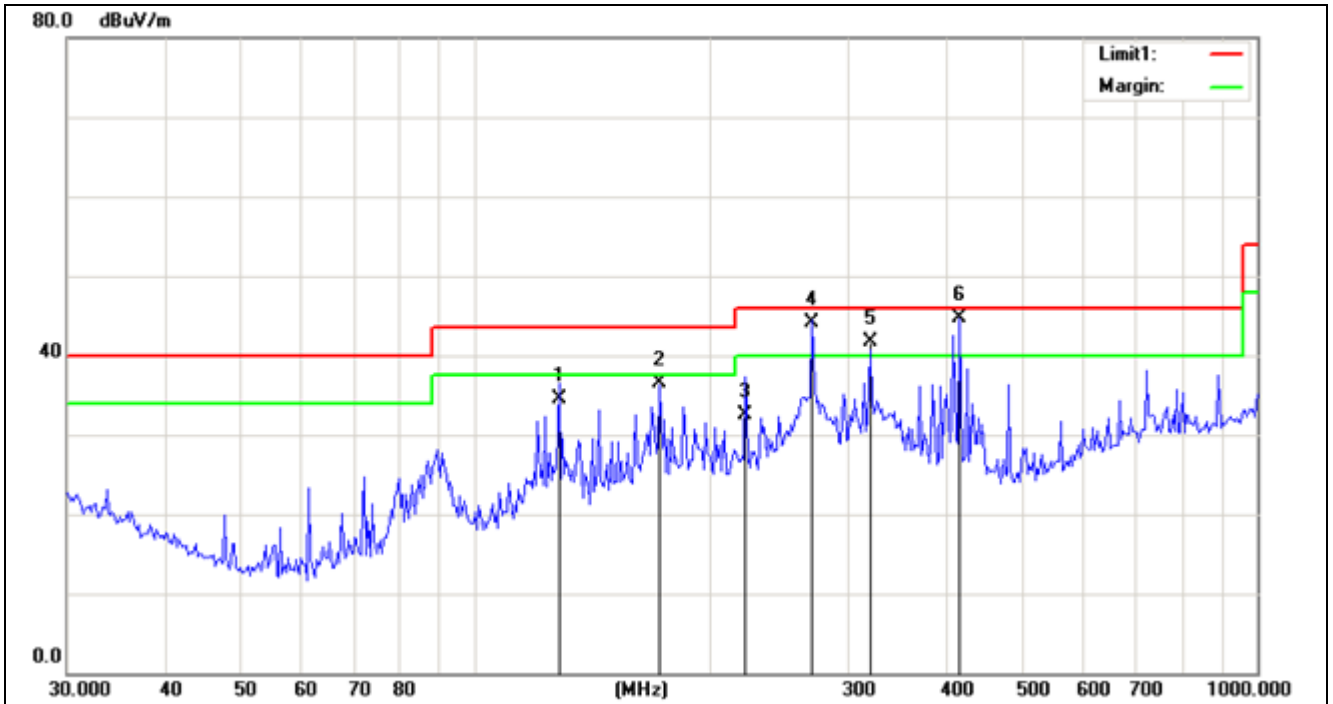

No.	Frequency (MHz)	Reading (dBuV/m)	Correct Factor(dB/m)	Result (dBuV/m)	Limit (dBuV/m)	Margin (dB)	Remark
1	127.8713	25.78	8.72	34.50	43.50	-9.00	QP
2	172.2345	25.87	10.63	36.50	43.50	-7.00	QP
3	221.7906	19.92	12.58	32.50	46.00	-13.50	QP
4	269.9983	30.05	14.15	44.20	46.00	-1.80	QP
5	319.5776	25.50	16.20	41.70	46.00	-4.30	QP
6	416.1791	26.49	18.31	44.80	46.00	-1.20	QP

Emission above 1GHz:

No.	Frequency (MHz)	Reading (dBuV/m)	Correct Factor(dB/m)	Result (dBuV/m)	Limit (dBuV/m)	Margin (dB)	Remark
1	1741.223	19.19	18.89	38.08	74.00	-35.92	peak
2	1741.223	5.21	18.89	24.10	54.00	-29.90	AVG
3	1835.663	25.00	19.03	44.03	74.00	-29.97	peak
4	1835.663	10.77	19.03	29.80	54.00	-24.20	AVG
5	3000.000	17.43	25.18	42.61	74.00	-31.39	peak
6	3000.000	3.12	25.18	28.30	54.00	-25.70	AVG
7	12937.883	27.62	27.20	54.82	74.00	-19.18	peak
8	12937.883	13.50	27.20	40.70	54.00	-13.30	AVG
9	16753.154	28.52	30.20	58.72	74.00	-15.28	peak
10	16753.154	14.30	30.20	44.50	54.00	-9.50	AVG
11	17845.610	28.21	31.74	59.95	74.00	-14.05	peak
12	17845.610	12.06	31.74	43.80	54.00	-10.20	AVG

Project No.:	ZJ00032008	Polarziation:	Vertical
Standard:	(RE)FCC PART 15 class B 3m	Power Source:	
Test item:	Radiation Test	Date:	2013-9-4
Temp./Hum.(%RH):	22.3/73%RH	Time:	15:52:51
EUT:	JBL AUTHENTICS L16	Distance:	3m
Model:	B-2437	Test Result:	Pass
Note:			

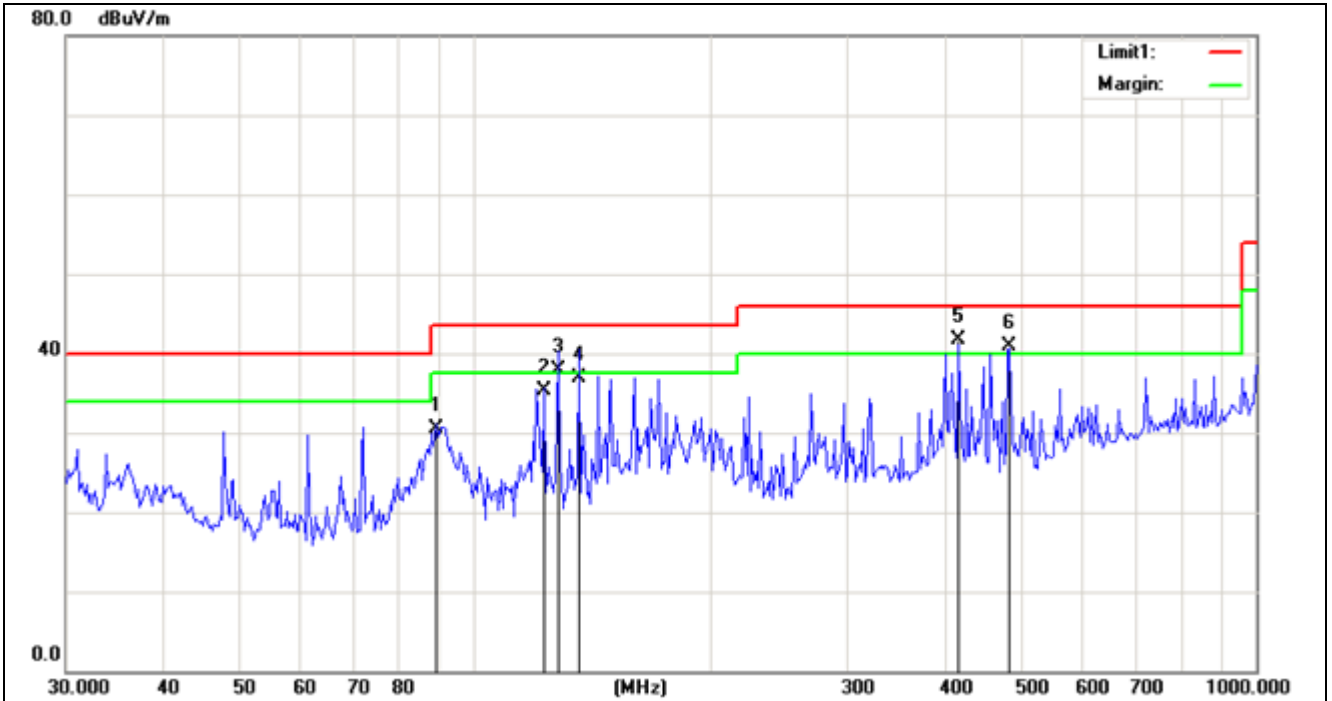

No.	Frequency (MHz)	Reading (dBuV/m)	Correct Factor(dB/m)	Result (dBuV/m)	Limit (dBuV/m)	Margin (dB)	Remark
1	89.2443	21.06	9.54	30.60	43.50	-12.90	QP
2	122.9389	26.50	8.80	35.30	43.50	-8.20	QP
3	127.8713	29.28	8.72	38.00	43.50	-5.50	QP
4	136.0250	28.02	8.98	37.00	43.50	-6.50	QP
5	416.1791	23.49	18.31	41.80	46.00	-4.20	QP
6	484.3665	20.95	19.95	40.90	46.00	-5.10	QP

Emission above 1GHz:

No.	Frequency (MHz)	Reading (dBuV/m)	Correct Factor(dB/m)	Result (dBuV/m)	Limit (dBuV/m)	Margin (dB)	Remark
1	1835.663	23.79	19.03	42.82	74.00	-31.18	peak
2	1835.663	9.27	19.03	28.30	54.00	-25.70	AVG
3	2271.494	18.00	22.80	40.80	74.00	-33.20	peak
4	2271.494	4.30	22.80	27.10	54.00	-26.90	AVG
5	2647.485	18.15	24.31	42.46	74.00	-31.54	peak
6	2647.485	4.79	24.31	29.10	54.00	-24.90	AVG
7	13860.922	28.70	29.78	58.48	74.00	-15.52	peak
8	13860.922	14.72	29.78	44.50	54.00	-9.50	AVG
9	16995.414	28.73	35.73	64.46	74.00	-9.54	peak
10	16995.414	15.47	35.73	51.20	54.00	-2.80	AVG
11	17896.926	28.46	36.03	64.49	74.00	-9.51	peak
12	17896.926	14.57	36.03	50.60	54.00	-3.40	AVG

Project No.:	ZJ00032008	Polarization:	Horizontal
Standard:	(RE)FCC PART 15 class B 3m	Power Source:	
Test item:	Radiation Test	Date:	2013-9-4
Temp./Hum.(%RH):	22.3/73%RH	Time:	15:59:52
EUT:	JBL AUTHENTICS L16	Distance:	3m
Model:	B-2437	Test Result:	Pass
Note:			

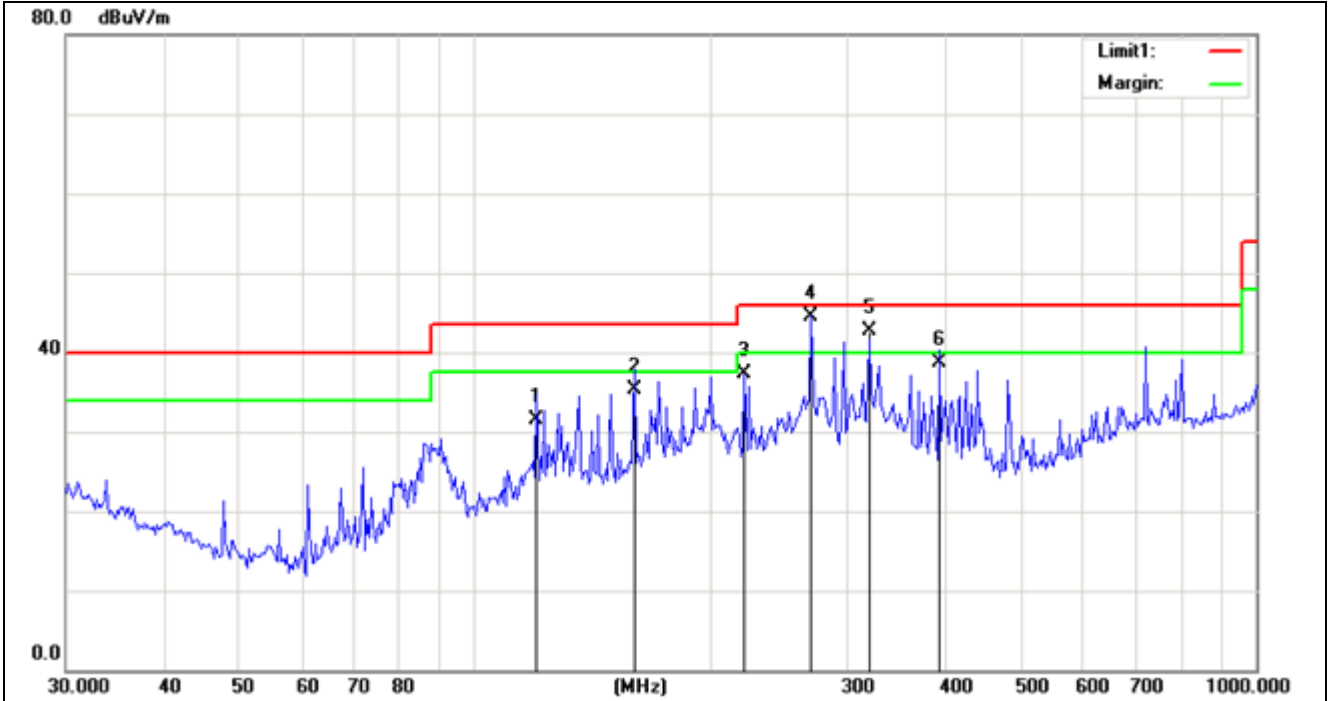

No.	Frequency (MHz)	Reading (dBuV/m)	Correct Factor(dB/m)	Result (dBuV/m)	Limit (dBuV/m)	Margin (dB)	Remark
1	120.2064	22.73	8.87	31.60	43.50	-11.90	QP
2	160.1008	24.71	10.69	35.40	43.50	-8.10	QP
3	221.7906	24.72	12.58	37.30	46.00	-8.70	QP
4	269.9983	30.35	14.15	44.50	46.00	-1.50	QP
5	319.5776	26.50	16.20	42.70	46.00	-3.30	QP
6	393.4370	20.74	18.06	38.80	46.00	-7.20	QP

Emission above 1GHz:

No.	Frequency (MHz)	Reading (dBuV/m)	Correct Factor(dB/m)	Result (dBuV/m)	Limit (dBuV/m)	Margin (dB)	Remark
1	1835.663	23.33	19.03	42.36	74.00	-31.64	peak
2	1835.663	6.87	19.03	25.90	54.00	-28.10	AVG
3	2761.749	18.29	23.98	42.27	74.00	-31.73	peak
4	2761.749	3.42	23.98	27.40	54.00	-26.60	AVG
5	2926.959	18.58	23.82	42.40	74.00	-31.60	peak
6	2926.959	5.08	23.82	28.90	54.00	-25.10	AVG
7	12463.836	28.79	26.32	55.11	74.00	-18.89	peak
8	12463.836	14.98	26.32	41.30	54.00	-12.70	AVG
9	14183.010	27.68	30.45	58.13	74.00	-15.87	peak
10	14183.010	13.45	30.45	43.90	54.00	-10.10	AVG
11	15282.394	28.20	31.58	59.78	74.00	-14.22	peak
12	15282.394	14.22	31.58	45.80	54.00	-8.20	AVG

Project No.:	ZJ00032008	Polarization:	Vertical
Standard:	(RE)FCC PART 15 class B 3m	Power Source:	
Test item:	Radiation Test	Date:	2013-9-4
Temp./Hum.(%RH):	22.3/73%RH	Time:	16:09:27
EUT:	JBL AUTHENTICS L16	Distance:	3m
Model:	B-2462	Test Result:	Pass
Note:			

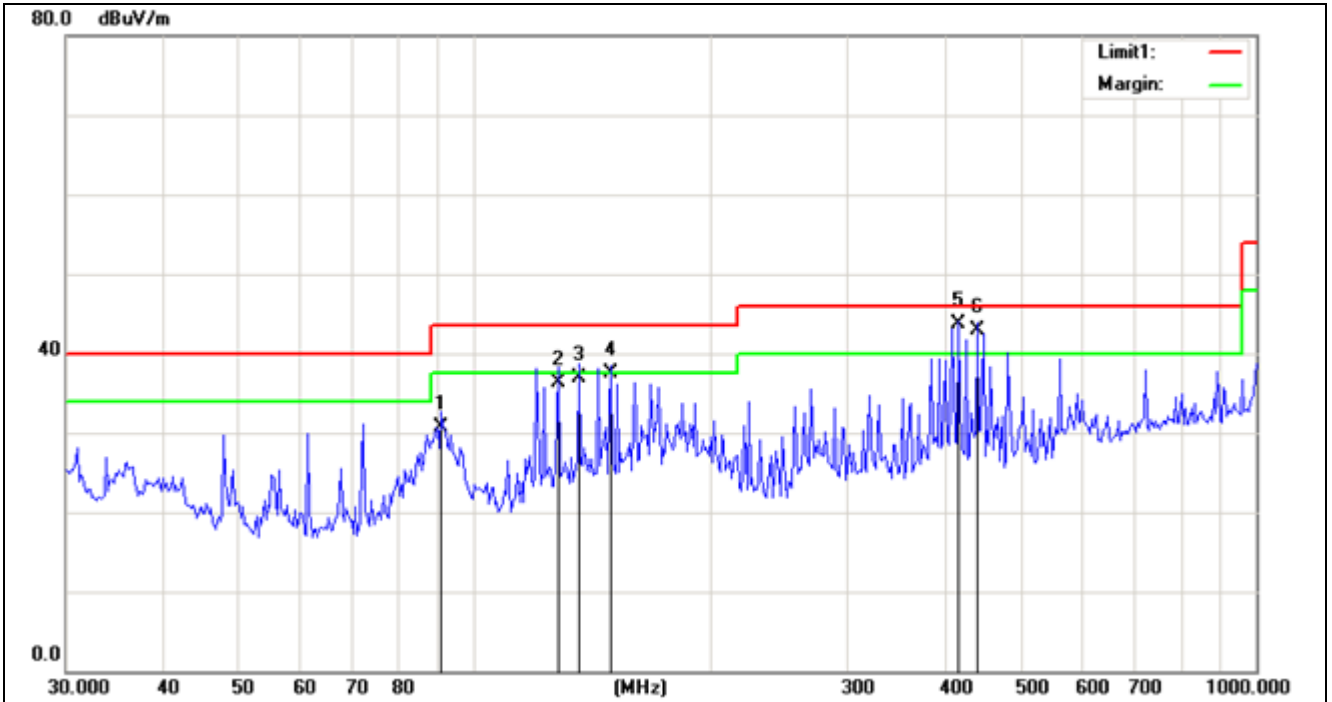

No.	Frequency (MHz)	Reading (dBuV/m)	Correct Factor(dB/m)	Result (dBuV/m)	Limit (dBuV/m)	Margin (dB)	Remark
1	90.7615	21.05	9.65	30.70	43.50	-12.80	QP
2	127.8713	27.58	8.72	36.30	43.50	-7.20	QP
3	136.0250	27.92	8.98	36.90	43.50	-6.60	QP
4	149.6606	27.40	10.10	37.50	43.50	-6.00	QP
5	416.1791	25.39	18.31	43.70	46.00	-2.30	QP
6	440.2359	24.23	18.67	42.90	46.00	-3.10	QP

Emission above 1GHz:

No.	Frequency (MHz)	Reading (dBuV/m)	Correct Factor(dB/m)	Result (dBuV/m)	Limit (dBuV/m)	Margin (dB)	Remark
1	1835.663	23.62	19.03	42.65	74.00	-31.35	peak
2	1835.663	6.37	19.03	25.40	54.00	-28.60	AVG
3	2415.869	21.25	24.23	45.48	74.00	-28.52	peak
4	2415.869	5.47	24.23	29.70	54.00	-24.30	AVG
5	2926.959	19.18	23.82	43.00	74.00	-31.00	peak
6	2926.959	6.88	23.82	30.70	54.00	-23.30	AVG
7	15414.608	28.52	31.73	60.25	74.00	-13.75	peak
8	15414.608	14.47	31.73	46.20	54.00	-7.80	AVG
9	16946.684	29.12	35.54	64.66	74.00	-9.34	peak
10	16946.684	15.26	35.54	50.80	54.00	-3.20	AVG
11	17390.339	29.15	35.56	64.71	74.00	-9.29	peak
12	17390.339	14.64	35.56	50.20	54.00	-3.80	AVG

Project No.:	ZJ00032008	Polarization:	Horizontal
Standard:	(RE)FCC PART 15 class B 3m	Power Source:	
Test item:	Radiation Test	Date:	2013-9-4
Temp./Hum.(%RH):	22.3/73%RH	Time:	16:12:28
EUT:	JBL AUTHENTICS L16	Distance:	3m
Model:	B-2462	Test Result:	Pass
Note:			

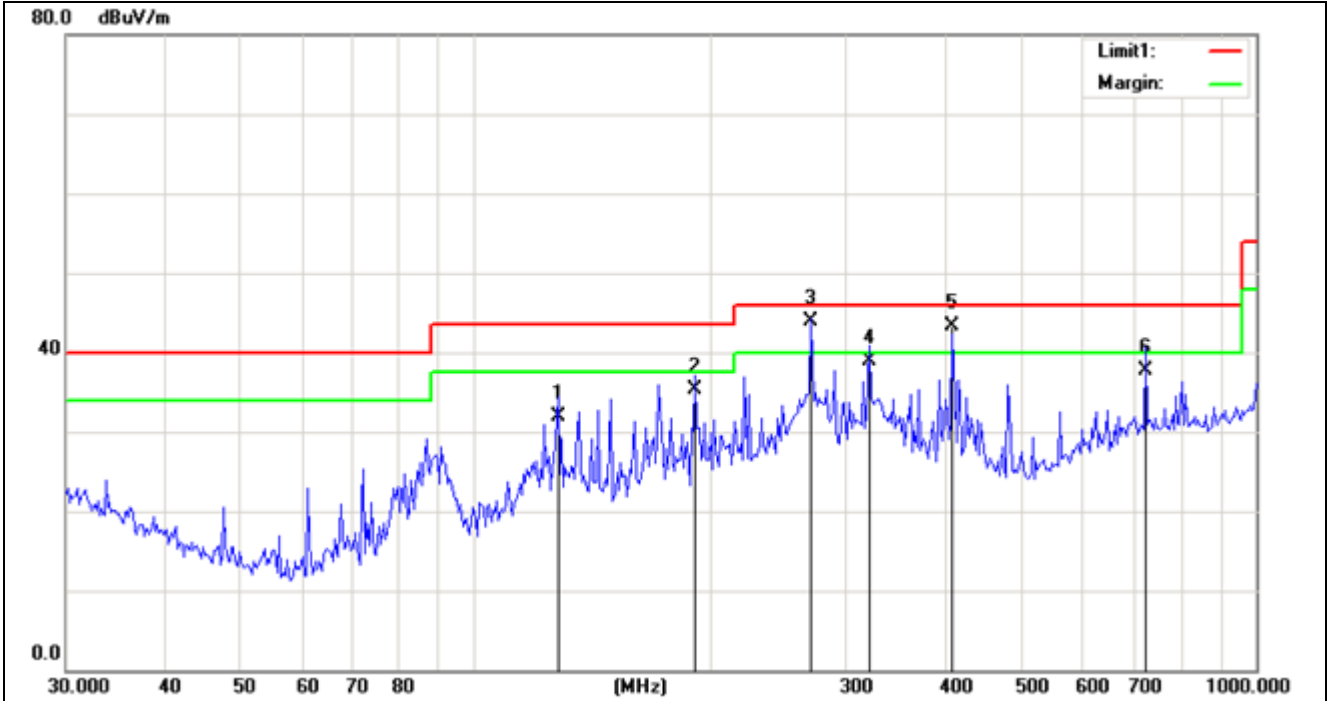

No.	Frequency (MHz)	Reading (dBuV/m)	Correct Factor(dB/m)	Result (dBuV/m)	Limit (dBuV/m)	Margin (dB)	Remark
1	127.8713	23.18	8.72	31.90	43.50	-11.60	QP
2	191.6416	23.95	11.45	35.40	43.50	-8.10	QP
3	269.9983	29.75	14.15	43.90	46.00	-2.10	QP
4	319.5776	22.80	16.20	39.00	46.00	-7.00	QP
5	409.2218	25.05	18.25	43.30	46.00	-2.70	QP
6	721.8557	13.46	24.24	37.70	46.00	-8.30	QP

Emission above 1GHz:

No.	Frequency (MHz)	Reading (dBuV/m)	Correct Factor(dB/m)	Result (dBuV/m)	Limit (dBuV/m)	Margin (dB)	Remark
1	1741.223	26.28	18.89	45.17	74.00	-28.83	peak
2	1741.223	8.21	18.89	27.10	54.00	-26.90	AVG
3	1835.663	24.31	19.03	43.34	74.00	-30.66	peak
4	1835.663	7.77	19.03	26.80	54.00	-27.20	AVG
5	2275.497	18.66	22.82	41.48	74.00	-32.52	peak
6	2275.497	4.28	22.82	27.10	54.00	-26.90	AVG
7	14388.105	26.93	30.82	57.75	74.00	-16.25	peak
8	14388.105	14.28	30.82	45.10	54.00	-8.90	AVG
9	15370.410	28.11	31.68	59.79	74.00	-14.21	peak
10	15370.410	14.72	31.68	46.40	54.00	-7.60	AVG
11	16849.641	28.08	35.14	63.22	74.00	-10.78	peak
12	16849.641	15.26	35.14	50.40	54.00	-3.60	AVG

Project No.:	ZJ00032008	Polarziation:	Vertical
Standard:	(RE)FCC PART 15 class B 3m	Power Source:	
Test item:	Radiation Test	Date:	2013-9-4
Temp./Hum.(%RH):	22.3/73%RH	Time:	16:17:06
EUT:	JBL AUTHENTICS L16	Distance:	3m
Model:	G-2412	Test Result:	Pass
Note:			

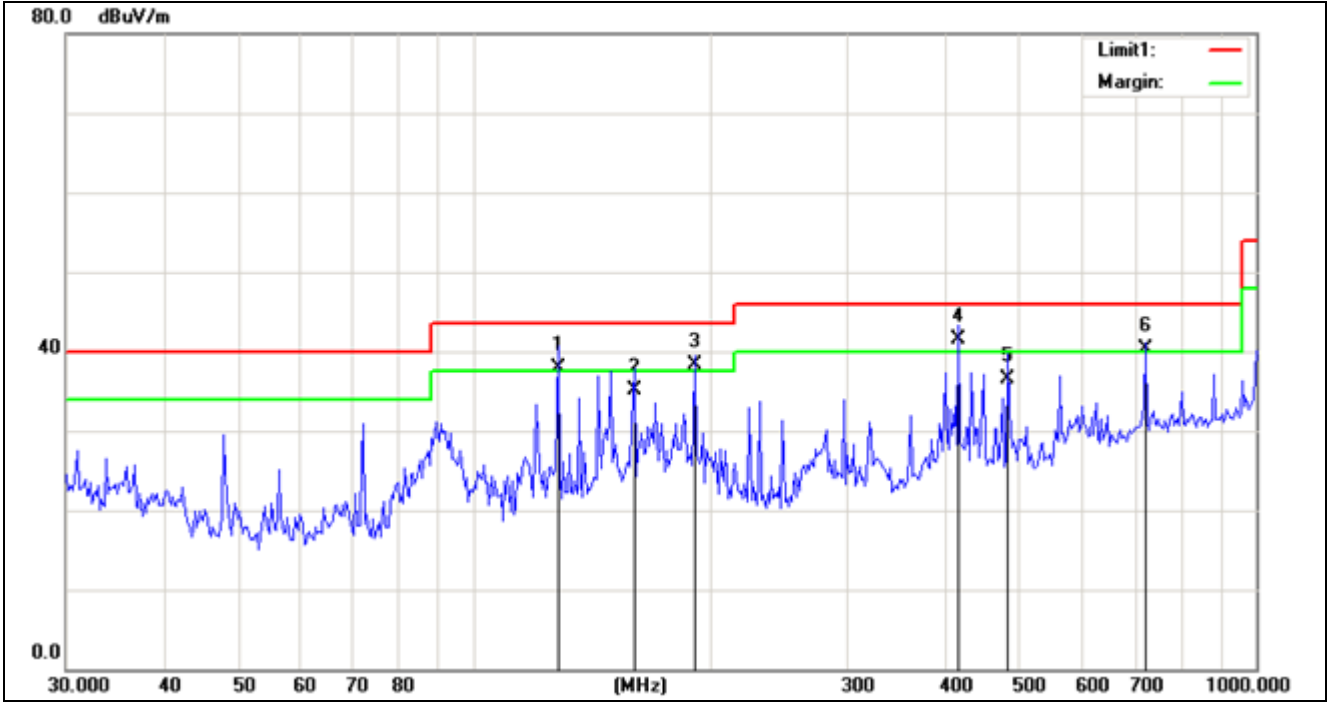

No.	Frequency (MHz)	Reading (dBuV/m)	Correct Factor(dB/m)	Result (dBuV/m)	Limit (dBuV/m)	Margin (dB)	Remark
1	127.8713	29.18	8.72	37.90	43.50	-5.60	QP
2	160.1008	24.41	10.69	35.10	43.50	-8.40	QP
3	191.6416	26.95	11.45	38.40	43.50	-5.10	QP
4	416.1791	23.29	18.31	41.60	46.00	-4.40	QP
5	481.6523	16.63	19.97	36.60	46.00	-9.40	QP
6	721.8557	16.06	24.24	40.30	46.00	-5.70	QP

Emission above 1GHz:

No.	Frequency (MHz)	Reading (dBuV/m)	Correct Factor(dB/m)	Result (dBuV/m)	Limit (dBuV/m)	Margin (dB)	Remark
1	1835.663	22.94	19.03	41.97	74.00	-32.03	peak
2	1835.663	6.87	19.03	25.90	54.00	-28.10	AVG
3	2015.198	18.77	20.83	39.60	74.00	-34.40	peak
4	2015.198	3.27	20.83	24.10	54.00	-29.90	AVG
5	2463.112	26.36	24.14	50.50	74.00	-23.50	peak
6	2463.112	9.16	24.14	33.30	54.00	-20.70	AVG
7	13507.307	28.65	28.94	57.59	74.00	-16.41	peak
8	13507.307	14.66	28.94	43.60	54.00	-10.40	AVG
9	14935.339	27.47	31.23	58.70	74.00	-15.30	peak
10	14935.339	14.47	31.23	45.70	54.00	-8.30	AVG
11	16946.684	29.47	35.54	65.01	74.00	-8.99	peak
12	16946.684	15.36	35.54	50.90	54.00	-3.10	AVG

Project No.:	ZJ00032008	Polarization:	Horizontal
Standard:	(RE)FCC PART 15 class B 3m	Power Source:	
Test item:	Radiation Test	Date:	2013-9-4
Temp./Hum.(%RH):	22.3/73%RH	Time:	16:20:37
EUT:	JBL AUTHENTICS L16	Distance:	3m
Model:	G-2412	Test Result:	Pass
Note:			

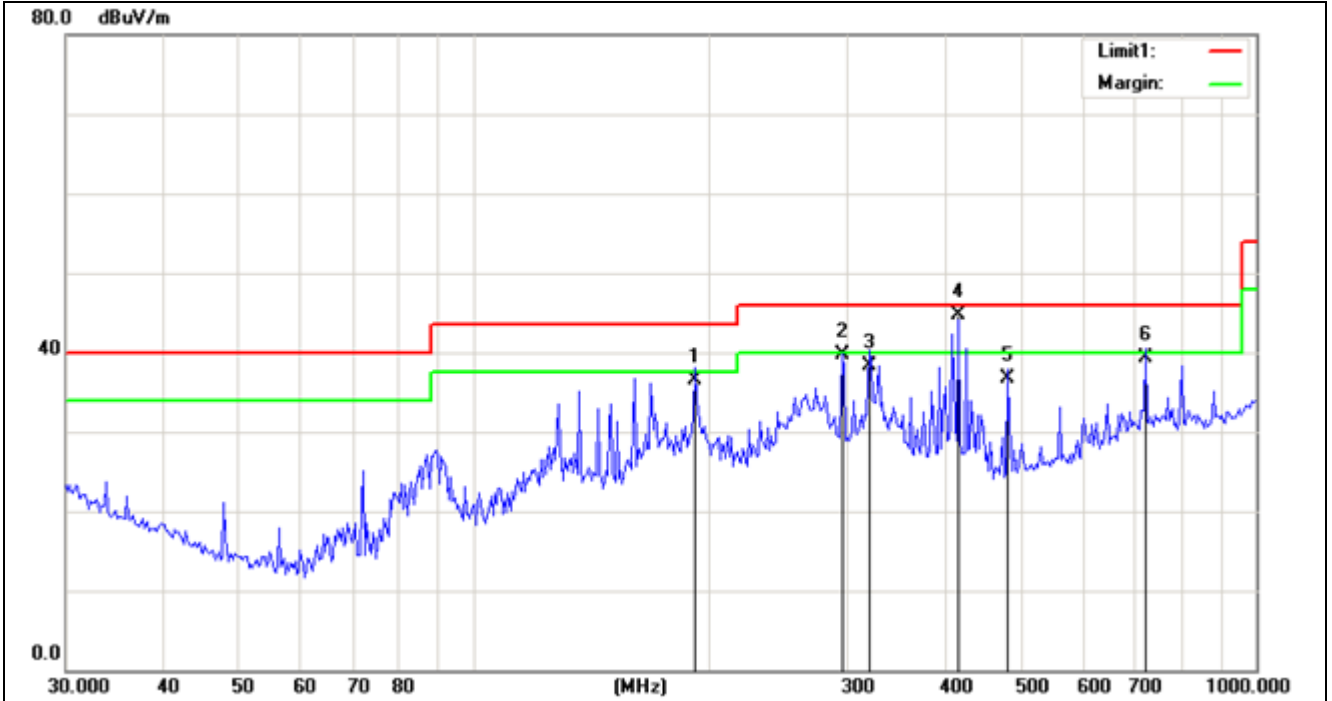

No.	Frequency (MHz)	Reading (dBuV/m)	Correct Factor(dB/m)	Result (dBuV/m)	Limit (dBuV/m)	Margin (dB)	Remark
1	191.6416	25.05	11.45	36.50	43.50	-7.00	QP
2	295.3991	24.79	14.91	39.70	46.00	-6.30	QP
3	319.5776	22.10	16.20	38.30	46.00	-7.70	QP
4	416.1791	26.39	18.31	44.70	46.00	-1.30	QP
5	481.6523	16.83	19.97	36.80	46.00	-9.20	QP
6	721.8557	15.16	24.24	39.40	46.00	-6.60	QP

Emission above 1GHz:

No.	Frequency (MHz)	Reading (dBuV/m)	Correct Factor(dB/m)	Result (dBuV/m)	Limit (dBuV/m)	Margin (dB)	Remark
1	1765.922	35.29	18.94	54.23	74.00	-19.77	peak
2	1765.922	15.56	18.94	34.50	54.00	-19.50	AVG
3	1835.663	25.73	19.03	44.76	74.00	-29.24	peak
4	1835.663	6.77	19.03	25.80	54.00	-28.20	AVG
5	2018.749	19.25	20.87	40.12	74.00	-33.88	peak
6	2018.749	3.03	20.87	23.90	54.00	-30.10	AVG
7	11667.287	28.21	24.81	53.02	74.00	-20.98	peak
8	11667.287	15.09	24.81	39.90	54.00	-14.10	AVG
9	14061.359	27.36	30.22	57.58	74.00	-16.42	peak
10	14061.359	14.28	30.22	44.50	54.00	-9.50	AVG
11	17540.791	29.21	35.55	64.76	74.00	-9.24	peak
12	17540.791	15.05	35.55	50.60	54.00	-3.40	AVG

Project No.:	ZJ00032008	Polarization:	Vertical
Standard:	(RE)FCC PART 15 class B 3m	Power Source:	
Test item:	Radiation Test	Date:	2013-9-4
Temp./Hum.(%RH):	22.3/73%RH	Time:	16:23:47
EUT:	JBL AUTHENTICS L16	Distance:	3m
Model:	G-2437	Test Result:	Pass
Note:			

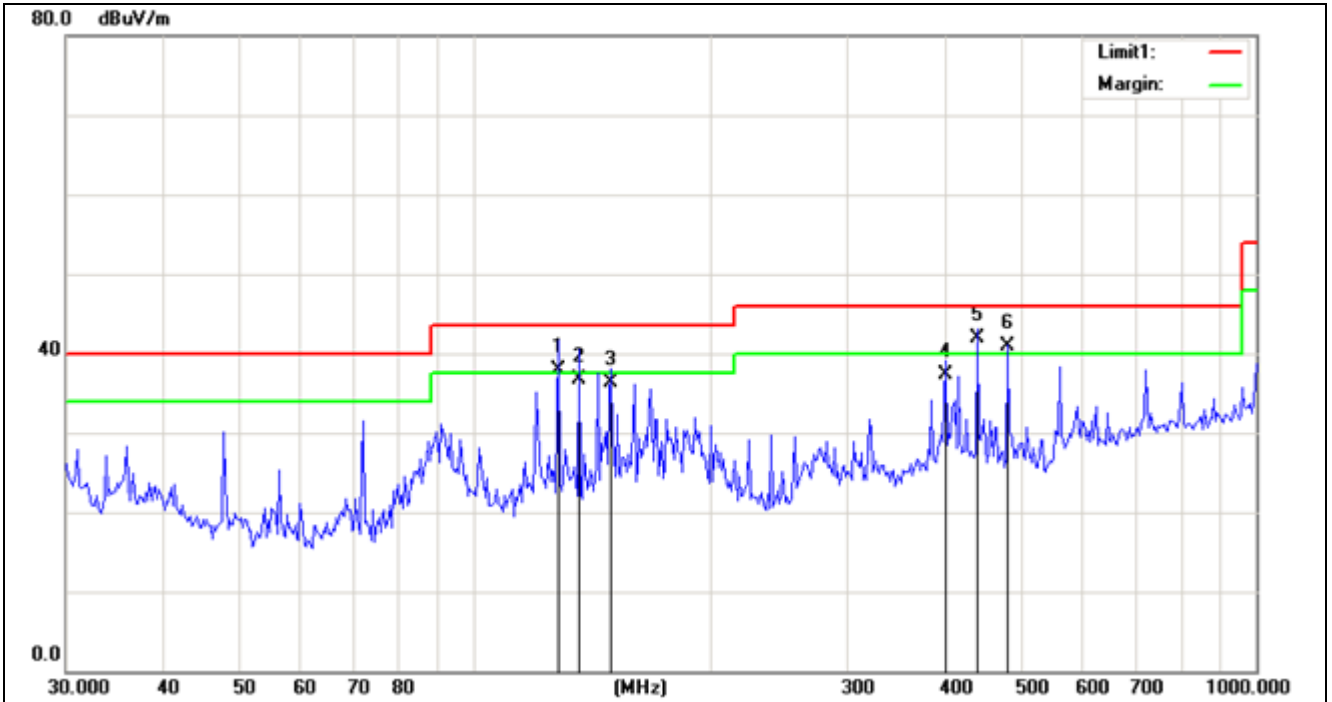

No.	Frequency (MHz)	Reading (dBuV/m)	Correct Factor(dB/m)	Result (dBuV/m)	Limit (dBuV/m)	Margin (dB)	Remark
1	127.8713	29.28	8.72	38.00	43.50	-5.50	QP
2	136.0250	27.72	8.98	36.70	43.50	-6.80	QP
3	149.6606	26.20	10.10	36.30	43.50	-7.20	QP
4	400.1260	19.21	18.19	37.40	46.00	-8.60	QP
5	440.2359	23.23	18.67	41.90	46.00	-4.10	QP
6	481.6523	20.93	19.97	40.90	46.00	-5.10	QP

Emission above 1GHz:

No.	Frequency (MHz)	Reading (dBuV/m)	Correct Factor(dB/m)	Result (dBuV/m)	Limit (dBuV/m)	Margin (dB)	Remark
1	1765.922	30.20	18.94	49.14	74.00	-24.86	peak
2	1765.922	13.16	18.94	32.10	54.00	-21.90	AVG
3	1835.663	23.24	19.03	42.27	74.00	-31.73	peak
4	1835.663	5.27	19.03	24.30	54.00	-29.70	AVG
5	2947.644	19.02	24.13	43.15	74.00	-30.85	peak
6	2947.644	4.57	24.13	28.70	54.00	-25.30	AVG
7	15194.881	27.47	31.49	58.96	74.00	-15.04	peak
8	15194.881	15.31	31.49	46.80	54.00	-7.20	AVG
9	17044.285	28.47	35.73	64.20	74.00	-9.80	peak
10	17044.285	16.17	35.73	51.90	54.00	-2.10	AVG
11	17948.389	29.10	36.10	65.20	74.00	-8.80	peak
12	17948.389	14.40	36.10	50.50	54.00	-3.50	AVG

Project No.:	ZJ00032008	Polarization:	Horizontal
Standard:	(RE)FCC PART 15 class B 3m	Power Source:	
Test item:	Radiation Test	Date:	2013-9-4
Temp./Hum.(%RH):	22.3/73%RH	Time:	16:27:48
EUT:	JBL AUTHENTICS L16	Distance:	3m
Model:	G-2437	Test Result:	Pass
Note:			

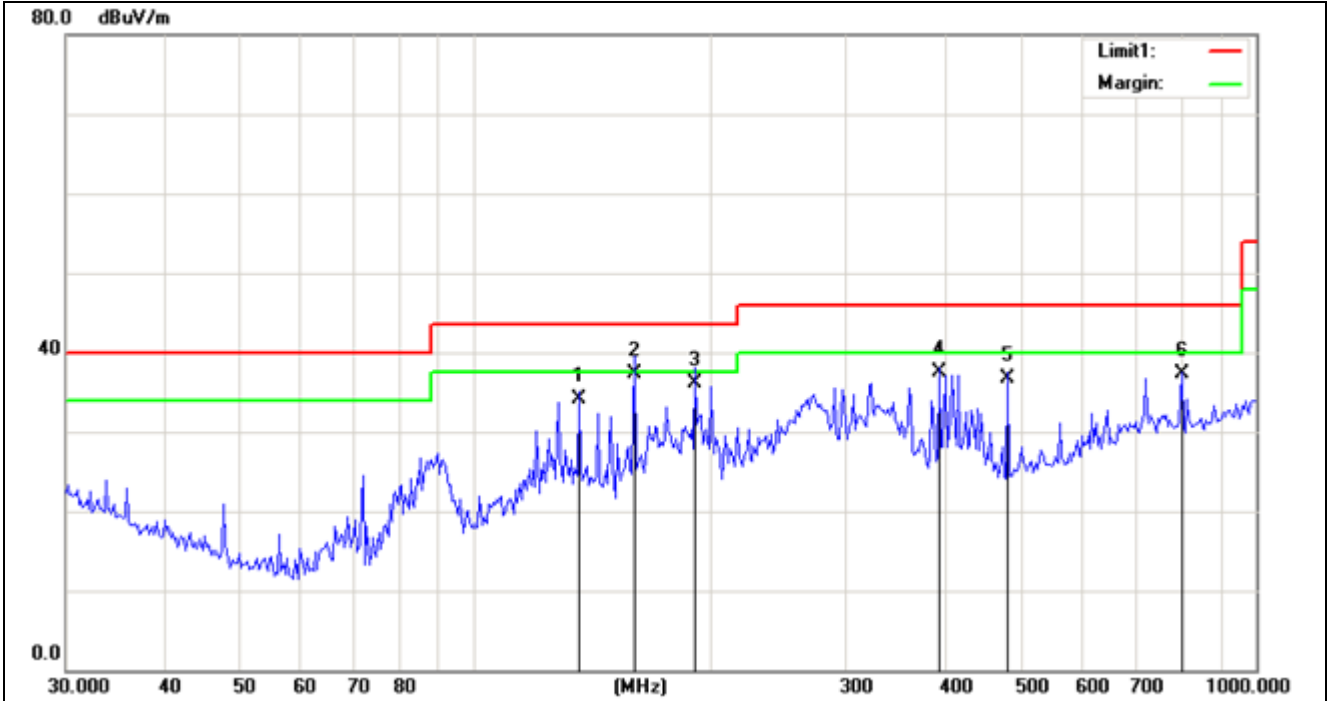

No.	Frequency (MHz)	Reading (dBuV/m)	Correct Factor(dB/m)	Result (dBuV/m)	Limit (dBuV/m)	Margin (dB)	Remark
1	136.0250	25.12	8.98	34.10	43.50	-9.40	QP
2	160.1008	26.71	10.69	37.40	43.50	-6.10	QP
3	191.6416	24.65	11.45	36.10	43.50	-7.40	QP
4	393.4370	19.44	18.06	37.50	46.00	-8.50	QP
5	481.6523	16.73	19.97	36.70	46.00	-9.30	QP
6	803.1933	12.31	25.09	37.40	46.00	-8.60	QP

Emission above 1GHz:

No.	Frequency (MHz)	Reading (dBuV/m)	Correct Factor(dB/m)	Result (dBuV/m)	Limit (dBuV/m)	Margin (dB)	Remark
1	1756.619	31.06	18.97	50.03	74.00	-23.97	peak
2	1756.619	13.93	18.97	32.90	54.00	-21.10	AVG
3	1835.663	22.90	19.03	41.93	74.00	-32.07	peak
4	1835.663	6.07	19.03	25.10	54.00	-28.90	AVG
5	2952.838	18.16	24.22	42.38	74.00	-31.62	peak
6	2952.838	3.08	24.22	27.30	54.00	-26.70	AVG
7	9736.582	28.21	25.26	53.47	74.00	-20.53	peak
8	9736.582	16.04	25.26	41.30	54.00	-12.70	AVG
9	13900.779	28.21	29.87	58.08	74.00	-15.92	peak
10	13900.779	15.03	29.87	44.90	54.00	-9.10	AVG
11	15682.479	28.80	32.37	61.17	74.00	-12.83	peak
12	15682.479	14.43	32.37	46.80	54.00	-7.20	AVG

Project No.:	ZJ00032008	Polarization:	Vertical
Standard:	(RE)FCC PART 15 class B 3m	Power Source:	
Test item:	Radiation Test	Date:	2013-9-4
Temp./Hum.(%RH):	22.3/73%RH	Time:	16:32:01
EUT:	JBL AUTHENTICS L16	Distance:	3m
Model:	G-2462	Test Result:	Pass
Note:			

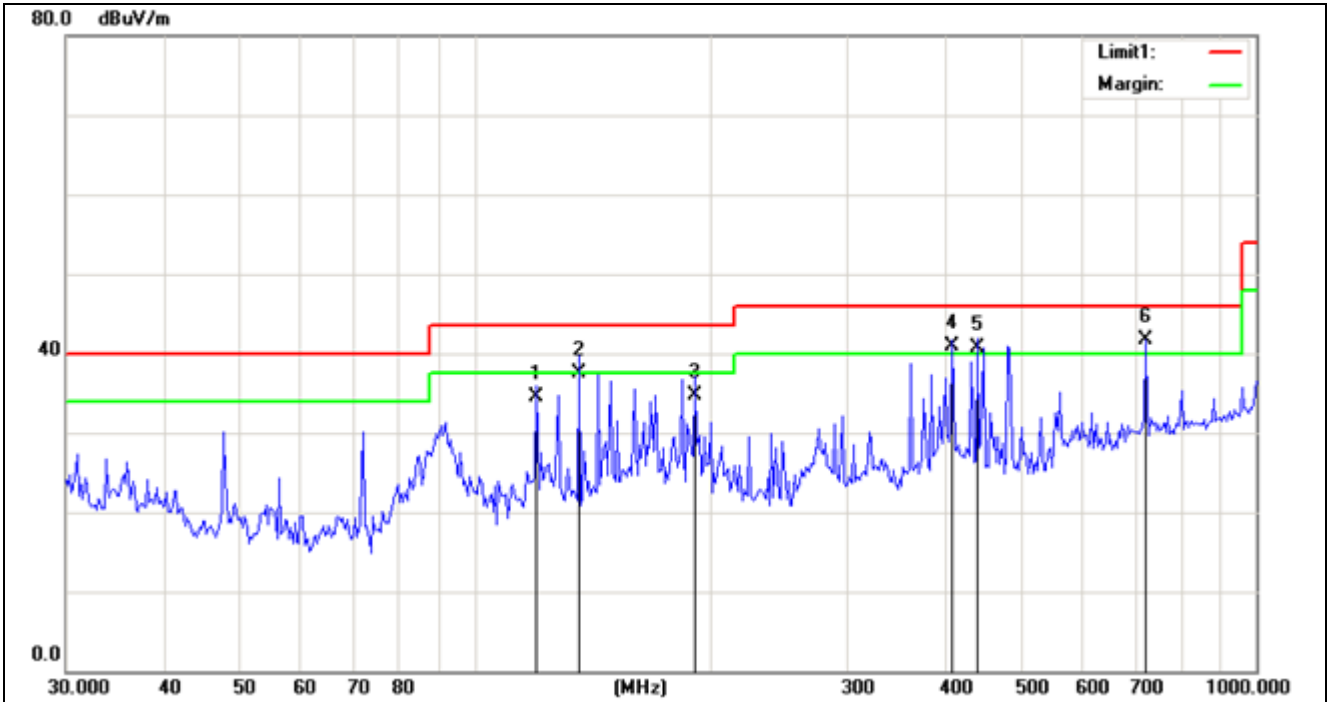

No.	Frequency (MHz)	Reading (dBuV/m)	Correct Factor(dB/m)	Result (dBuV/m)	Limit (dBuV/m)	Margin (dB)	Remark
1	120.2064	25.63	8.87	34.50	43.50	-9.00	QP
2	136.0250	28.62	8.98	37.60	43.50	-5.90	QP
3	191.6416	23.35	11.45	34.80	43.50	-8.70	QP
4	409.2218	22.65	18.25	40.90	46.00	-5.10	QP
5	440.2359	22.13	18.67	40.80	46.00	-5.20	QP
6	721.8557	17.46	24.24	41.70	46.00	-4.30	QP

Emission above 1GHz:

No.	Frequency (MHz)	Reading (dBuV/m)	Correct Factor(dB/m)	Result (dBuV/m)	Limit (dBuV/m)	Margin (dB)	Remark
1	1835.663	23.59	19.03	42.62	74.00	-31.38	peak
2	1835.663	7.57	19.03	26.60	54.00	-27.40	AVG
3	2737.544	17.77	24.14	41.91	74.00	-32.09	peak
4	2737.544	5.76	24.14	29.90	54.00	-24.10	AVG
5	2942.459	18.42	24.05	42.47	74.00	-31.53	peak
6	2942.459	7.35	24.05	31.40	54.00	-22.60	AVG
7	10491.305	28.44	24.62	53.06	74.00	-20.94	peak
8	10491.305	15.48	24.62	40.10	54.00	-13.90	AVG
9	15370.410	28.14	31.68	59.82	74.00	-14.18	peak
10	15370.410	14.62	31.68	46.30	54.00	-7.70	AVG
11	16946.684	27.41	35.54	62.95	74.00	-11.05	peak
12	16946.684	15.06	35.54	50.60	54.00	-3.40	AVG

Project No.:	ZJ00032008	Polarization:	Horizontal
Standard:	(RE)FCC PART 15 class B 3m	Power Source:	
Test item:	Radiation Test	Date:	2013-9-4
Temp./Hum.(%RH):	22.3/73%RH	Time:	16:33:42
EUT:	JBL AUTHENTICS L16	Distance:	3m
Model:	G-2462	Test Result:	Pass
Note:			

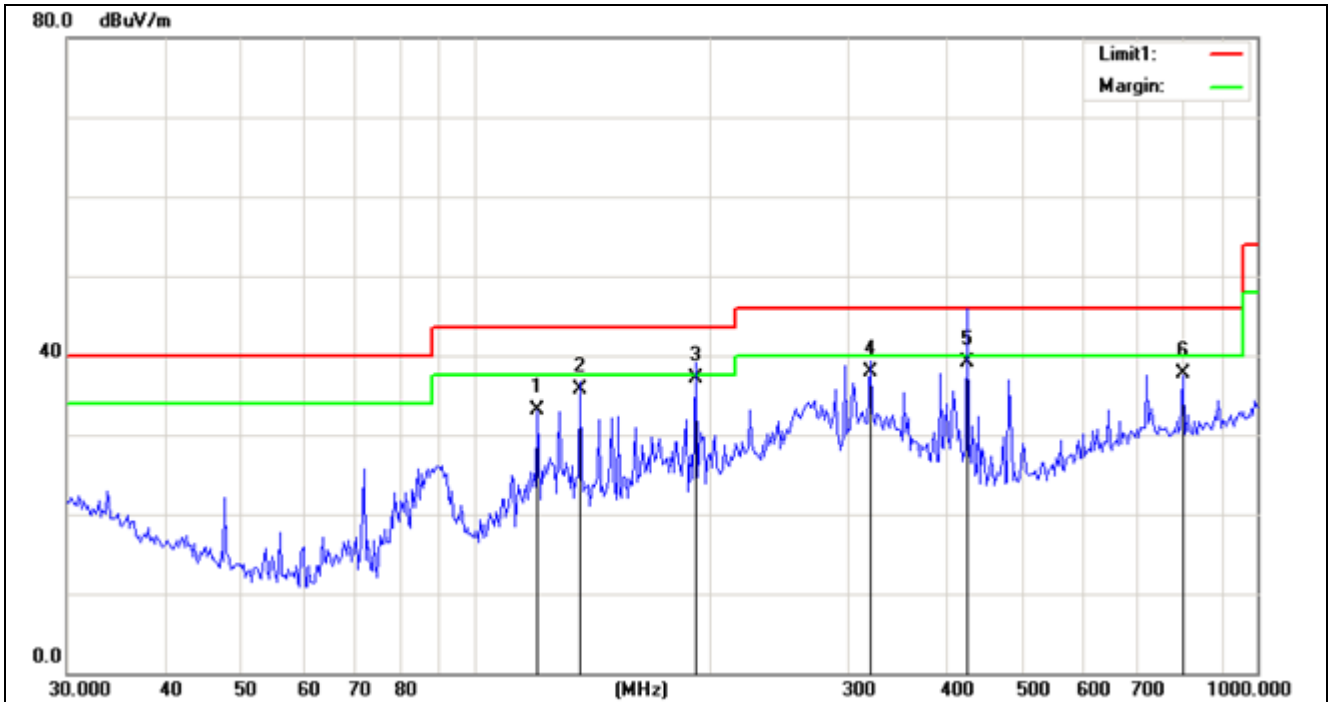

No.	Frequency (MHz)	Reading (dBuV/m)	Correct Factor(dB/m)	Result (dBuV/m)	Limit (dBuV/m)	Margin (dB)	Remark
1	120.2064	24.23	8.87	33.10	43.50	-10.40	QP
2	136.0250	26.72	8.98	35.70	43.50	-7.80	QP
3	191.6416	25.65	11.45	37.10	43.50	-6.40	QP
4	319.5776	21.70	16.20	37.90	46.00	-8.10	QP
5	425.6399	20.85	18.35	39.20	46.00	-6.80	QP
6	803.1933	12.71	25.09	37.80	46.00	-8.20	QP

Emission above 1GHz:

No.	Frequency (MHz)	Reading (dBuV/m)	Correct Factor(dB/m)	Result (dBuV/m)	Limit (dBuV/m)	Margin (dB)	Remark
1	1835.663	23.37	19.03	42.40	74.00	-31.60	peak
2	1835.663	8.17	19.03	27.20	54.00	-26.80	AVG
3	2761.749	17.79	23.98	41.77	74.00	-32.23	peak
4	2761.749	5.72	23.98	29.70	54.00	-24.30	AVG
5	2958.042	17.73	24.32	42.05	74.00	-31.95	peak
6	2958.042	6.68	24.32	31.00	54.00	-23.00	AVG
7	13353.055	28.28	28.73	57.01	74.00	-16.99	peak
8	13353.055	14.47	28.73	43.20	54.00	-10.80	AVG
9	16278.943	28.31	33.54	61.85	74.00	-12.15	peak
10	16278.943	14.26	33.54	47.80	54.00	-6.20	AVG
11	16995.414	29.19	35.73	64.92	74.00	-9.08	peak
12	16995.414	14.57	35.73	50.30	54.00	-3.70	AVG

Note: Below 30MHz, since the radiated emission of the EUT is too weak to be detected.

7. 6dB BANDWIDTH TESTING

7.1 LIMITS

Systems using digital modulation techniques may operate in the 902–928 MHz, 2400–2483.5 MHz, and 5725–5850 MHz bands. The minimum 6 dB bandwidth shall be at least 500 kHz.

7.2 TEST PROCEDURES

Test procedures follow KDB 558074 D01 DTS Measurement Guidance v03r01.

1. Check the calibration of the measuring instrument using either an internal calibrator or a known signal from an external generator.
2. Position the EUT without connection to measurement instrument. Turn on the EUT and connect it to measurement instrument. Then set it to any one convenient frequency within its operating range. Set a reference level on the measuring instrument equal to the highest peak value.
3. Set resolution bandwidth (RBW) = 100kHz. Set the video bandwidth (VBW) $\geq 3 \times$ RBW. Detector = Peak. Trace mode = max hold. Sweep = auto couple. Allow the trace to stabilize.
4. Measure the maximum width of the emission that is constrained by the frequencies associated with the two outermost amplitude points (upper and lower) that are attenuated by 6 dB relative to the maximum level measured in the fundamental emission. Compare the resultant bandwidth with the RBW setting of the analyzer.
5. Repeat above procedures until all frequencies measured were complete.

7.3 TEST SETUP

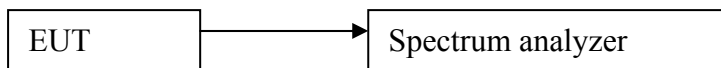

7.4 TEST RESULTS

Channel	Channel Frequency (MHz)	Data Rate (Mbps)	6dB Bandwidth (MHz)	Limit (kHz)
802.11b Mode				
Low Channel	2412	11	12.08	> 500
Middle Channel	2437	11	12.24	> 500
High Channel	2462	11	12.32	> 500

802.11b mode:
Channel 2412MHz

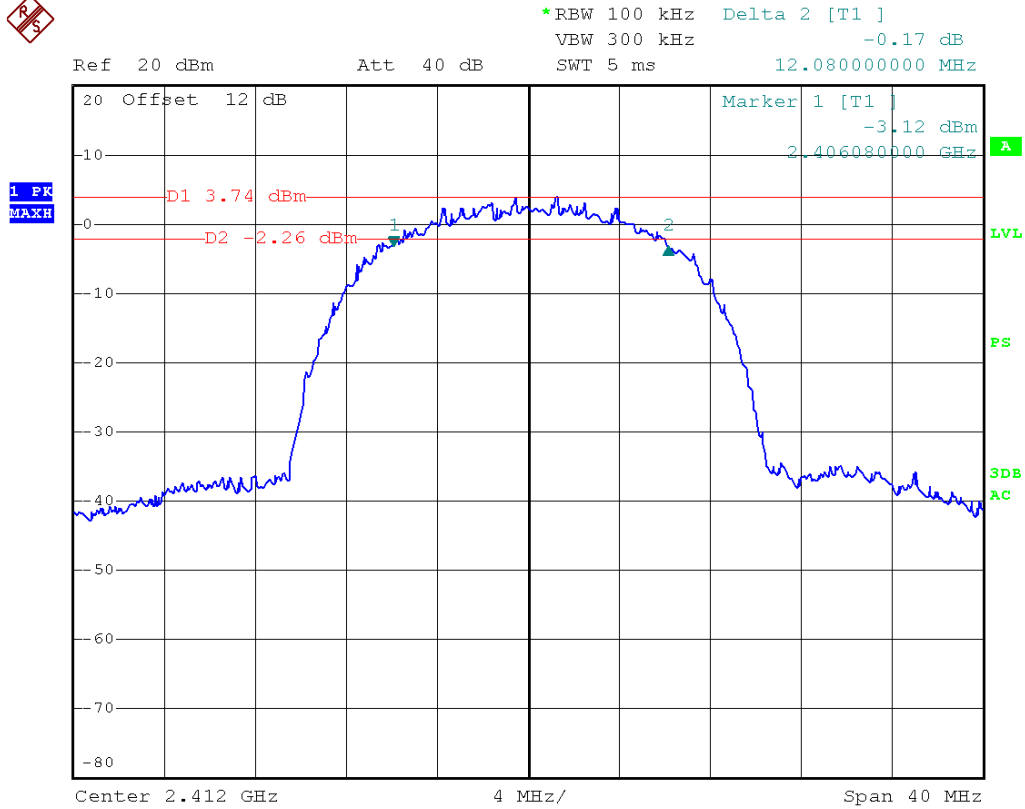

Channel 2437MHz

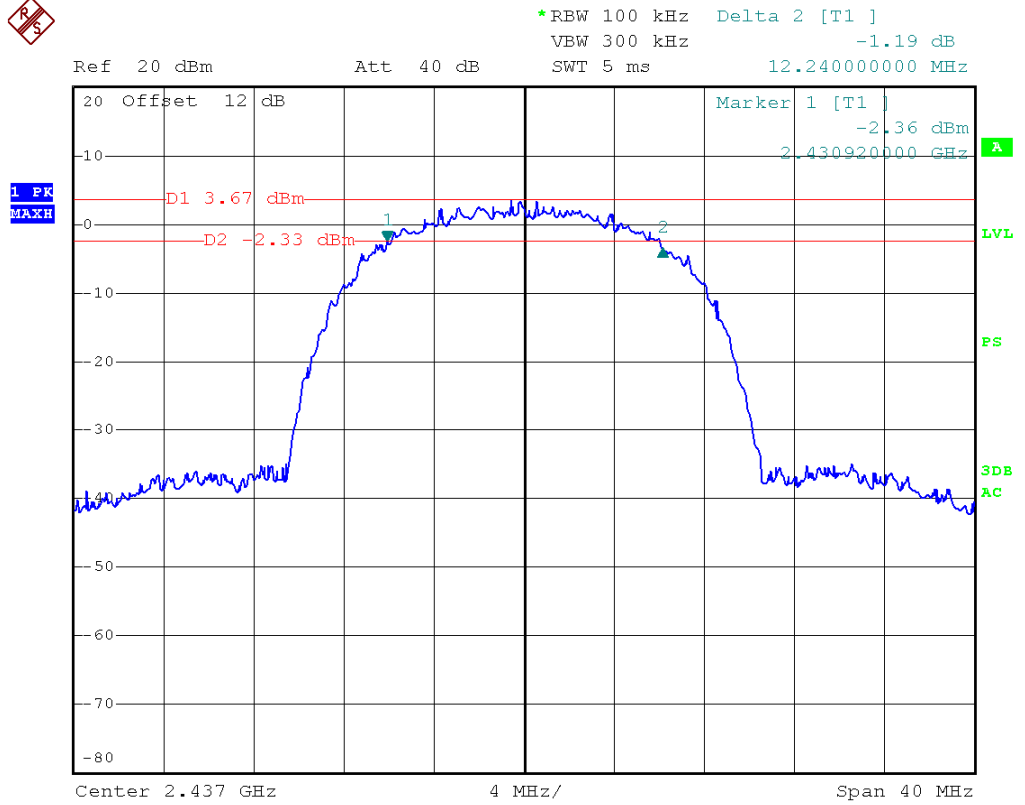

Channel 2462MHz



*RBW 100 kHz Delta 2 [T1]
VBW 300 kHz 1.22 dB
SWT 5 ms 12.320000000 MHz

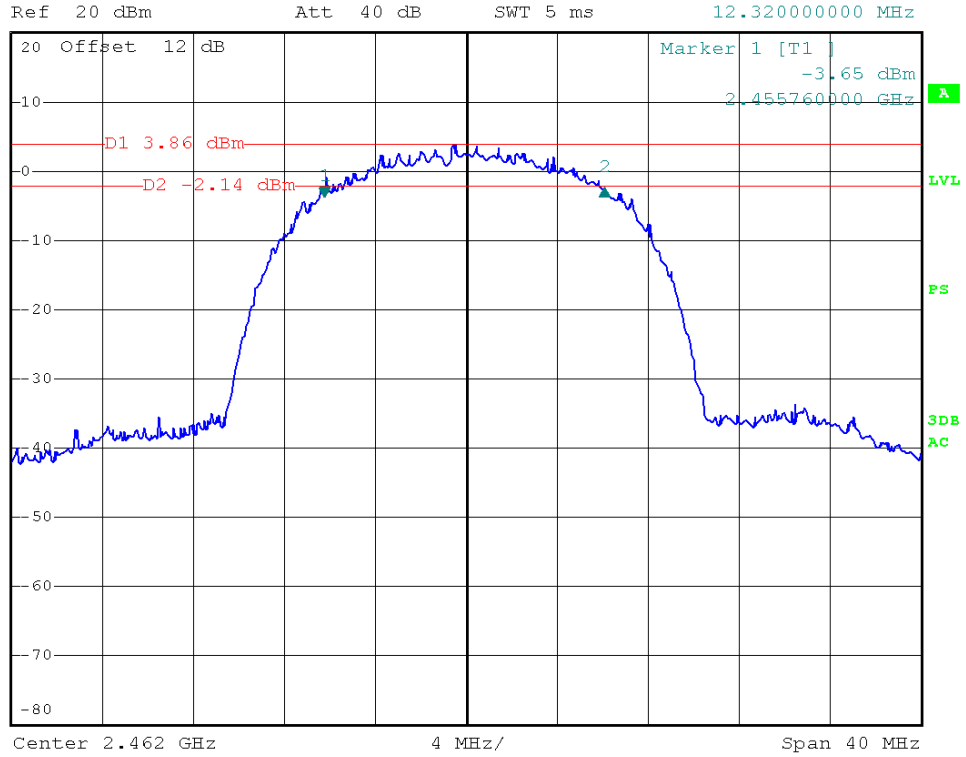

Channel	Channel Frequency (MHz)	Data Rate (Mbps)	6dB Bandwidth (MHz)	Limit (kHz)
802.11g Mode				
Low Channel	2412	54	16.64	> 500
Middle Channel	2437	54	16.64	> 500
High Channel	2462	54	16.64	> 500

802.11g mode:
Channel 2412MHz

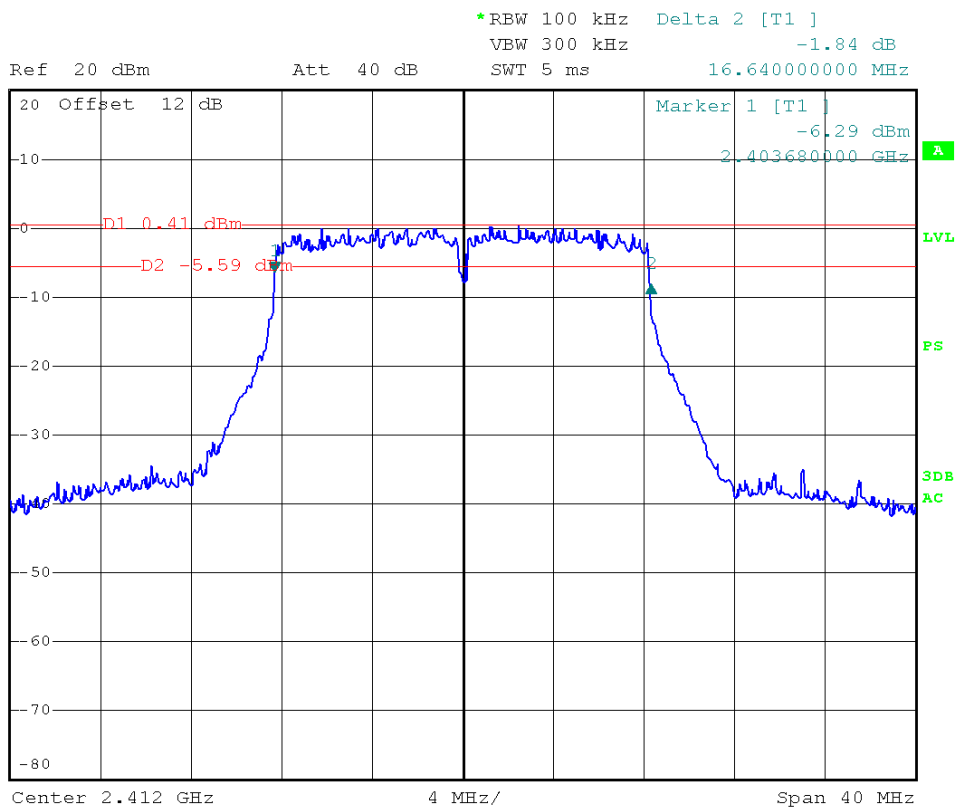

Channel 2437MHz



*RBW 100 kHz Delta 2 [T1]
VBW 300 kHz -0.99 dB
SWT 5 ms 16.640000000 MHz

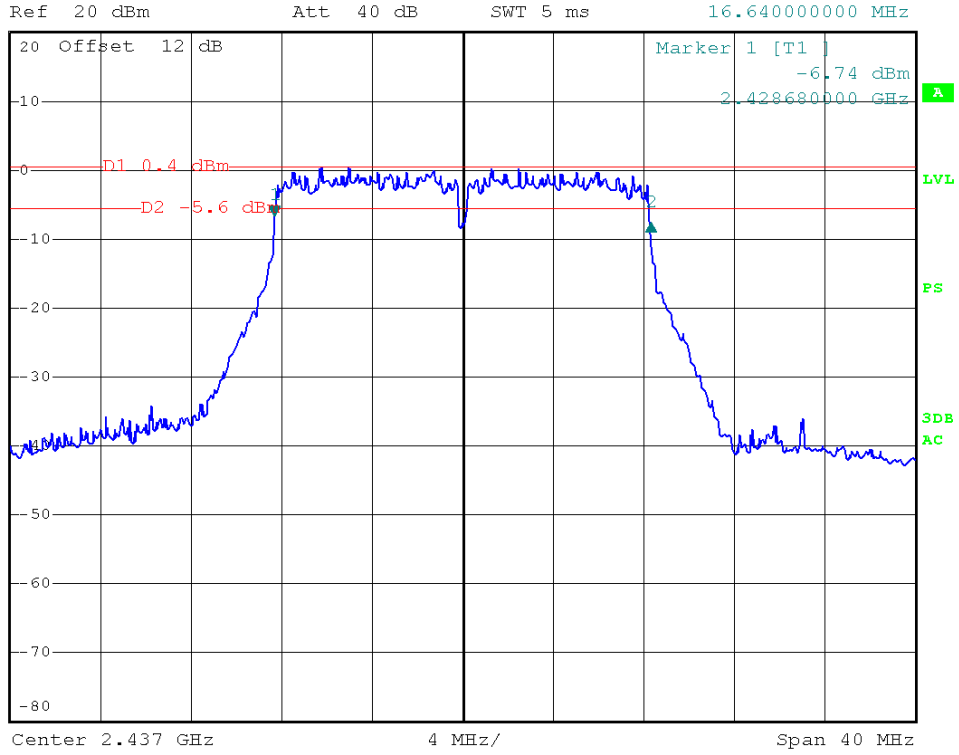

Channel 2462MHz



*RBW 100 kHz Delta 2 [T1]
VBW 300 kHz -2.12 dB
SWT 5 ms 16.640000000 MHz

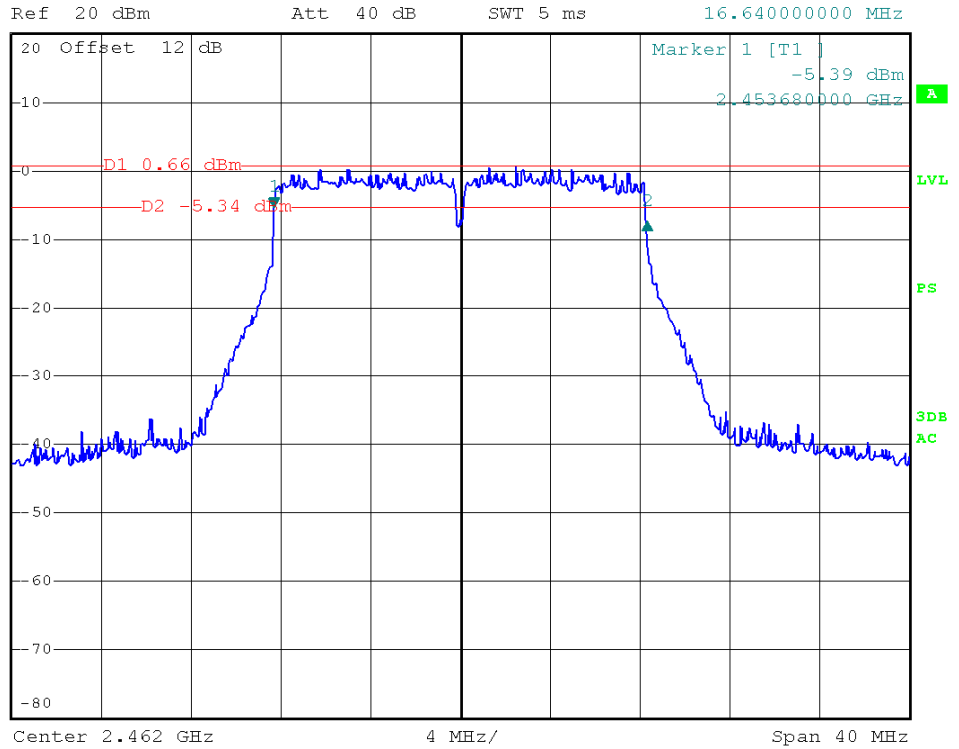

8. MAXIMUM PEAK OUTPUT POWER

8.1 LIMITS

The maximum Peak output power measurement is 1W

8.2 TEST PROCEDURES

Test procedures follow KDB 558074 D01 DTS Measurement Guidance v03r01.

1. Place the EUT on a bench and set it in transmitting mode.
2. Remove the antenna from the EUT and then connect a low loss RF cable from the antenna port to an EMI Test Receiver.
3. The spectrum analyzer resolution bandwidth that is \leq EBW. So we test the Maximum Conducted Output Power — Integrated band power method.
4. Set the analyzer span \geq 1.5 x DTS bandwidth. Set the RBW = 1 MHz. Set the VBW \geq 3 MHz. Sweep time = auto couple. Detector = peak. Allow trace to fully stabilize.

8.3 TEST SETUP

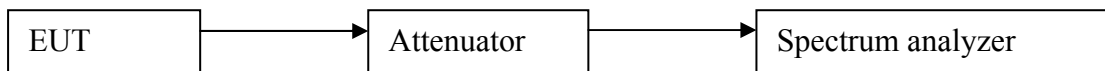

8.4 TEST RESULTS

802.11b Mode:

Channel No.	Frequency (MHz)	Mode	Data Rate	Measured Channel Power (dBm)	Limit	Result
1	2412	802.11b	1Mbps	19.47	1W (30dBm)	Pass
6	2437			19.28		Pass
11	2462			19.50		Pass
1	2412		2Mps	19.49		Pass
6	2437			19.29		Pass
11	2462			19.53		Pass
1	2412		5.5Mbps	19.52		Pass
6	2437			19.32		Pass
11	2462			19.56		Pass
1	2412		11Mbps	19.55		Pass
6	2437			19.33		Pass
11	2462			19.58		Pass

802.11b mode: 11Mbps
Channel 2412MHz

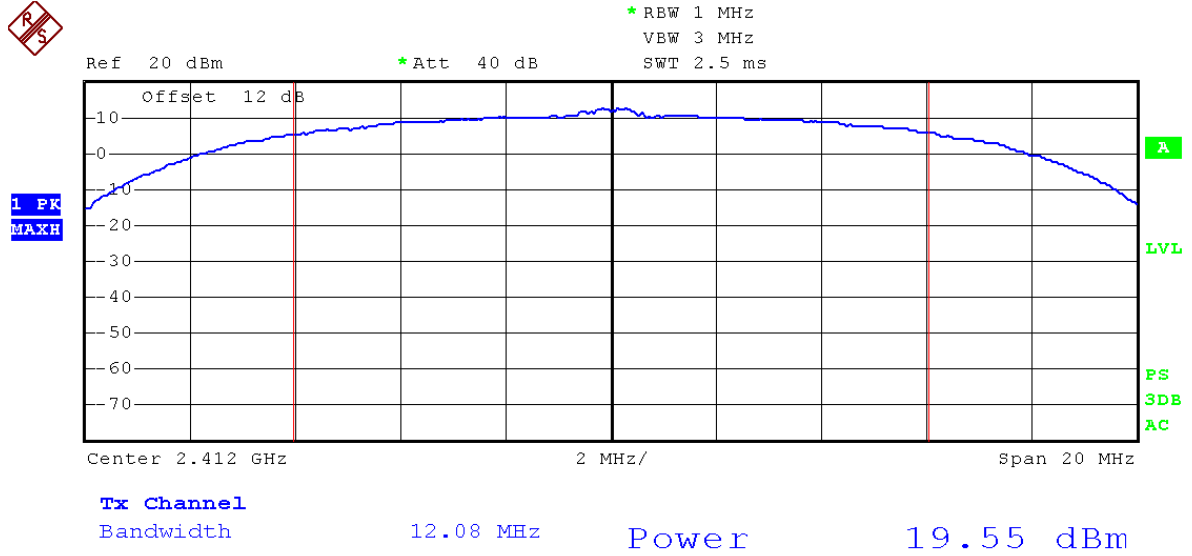

Channel 2437MHz

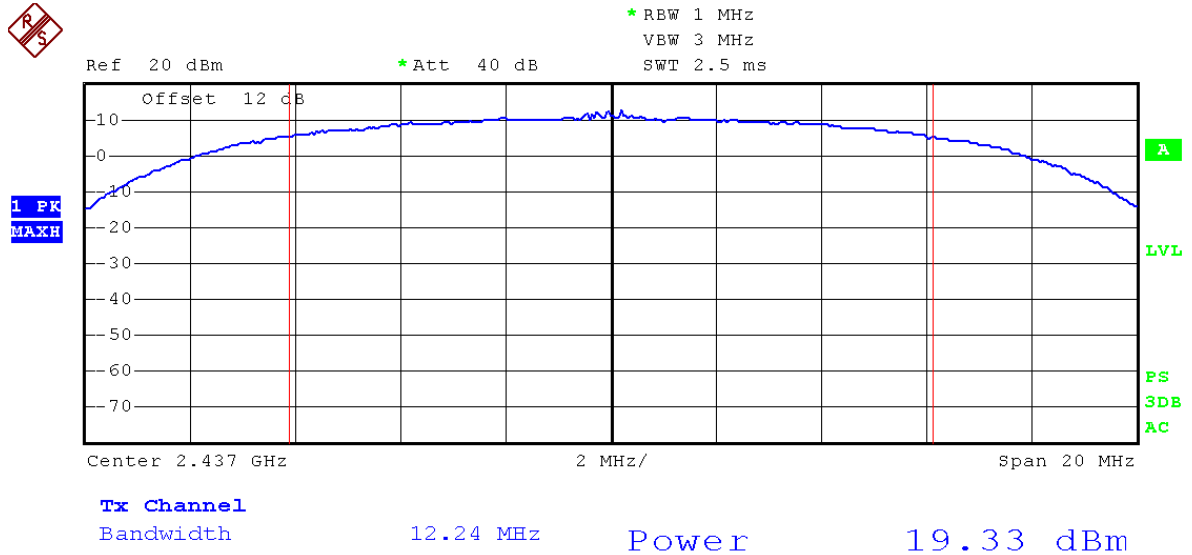

Channel 2462MHz

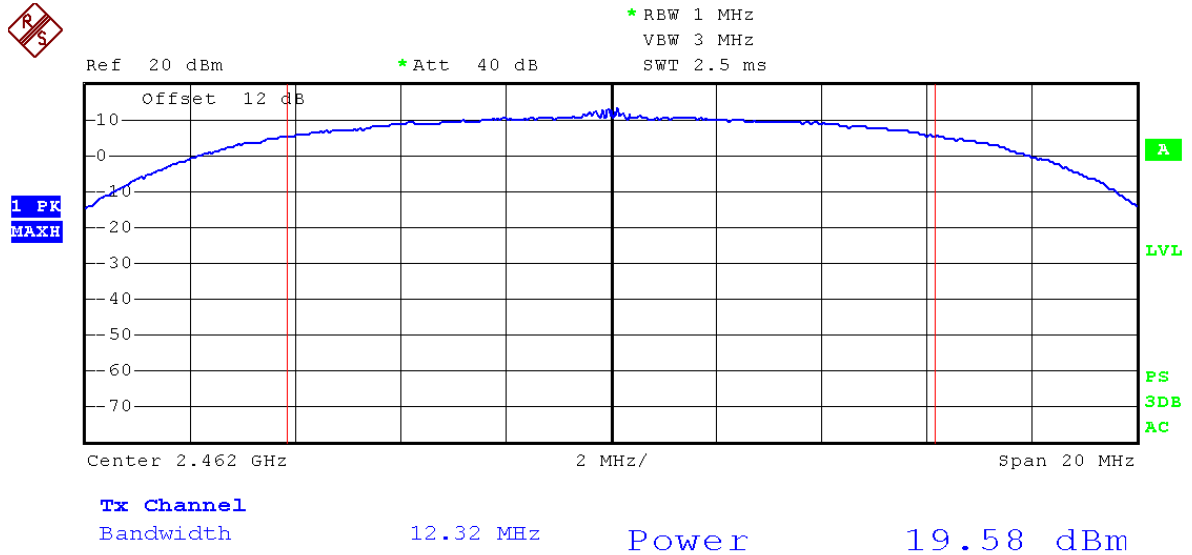

802.11g Mode:

Channel No.	Frequency (MHz)	Mode	Data Rate	Measured Channel Power (dBm)	Limit	Result
1	2412	802.11g	6Mbps	20.38	1W (30dBm)	Pass
6	2437			20.72		Pass
11	2462			20.63		Pass
1	2412		9Mbps	20.41		Pass
6	2437			20.75		Pass
11	2462			20.65		Pass
1	2412		12Mbps	20.47		Pass
6	2437			20.07		Pass
11	2462			20.80		Pass
1	2412		18Mbps	20.50		Pass
6	2437			20.09		Pass
11	2462			20.82		Pass
1	2412		24Mbps	20.54		Pass
6	2437			20.14		Pass
11	2462			20.84		Pass
1	2412		36Mbps	20.58		Pass
6	2437			20.85		Pass
11	2462			20.78		Pass
1	2412		48Mbps	20.63		Pass
6	2437			20.88		Pass
11	2462			20.83		Pass
1	2412	54Mbps	20.65	Pass		
6	2437		20.95	Pass		
11	2462		20.88	Pass		

802.11g mode: 54Mbps
Channel 2412MHz

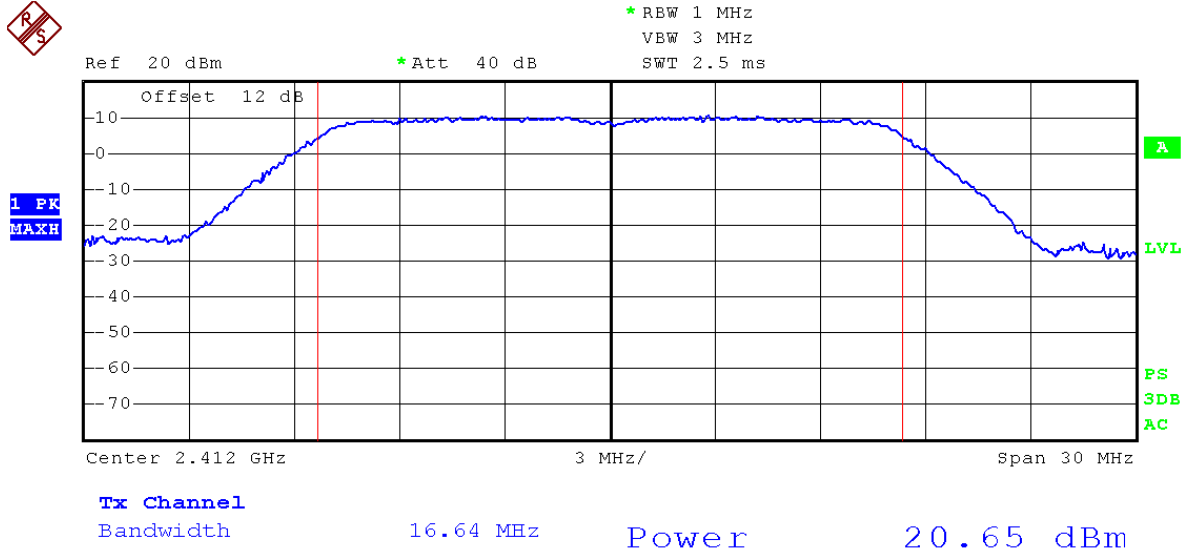

Channel 2437MHz

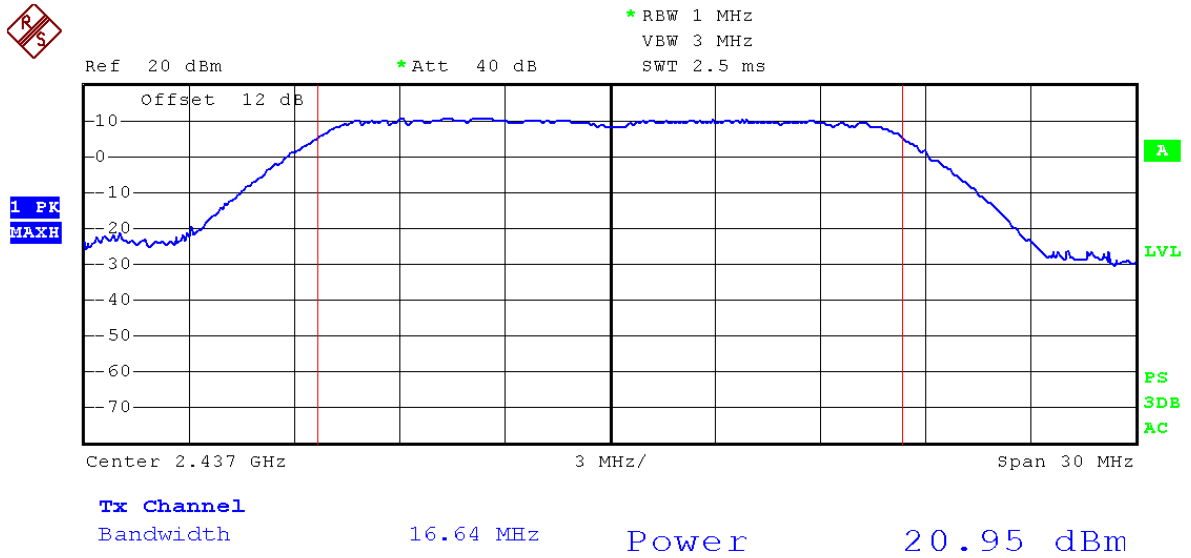

Channel 2462MHz

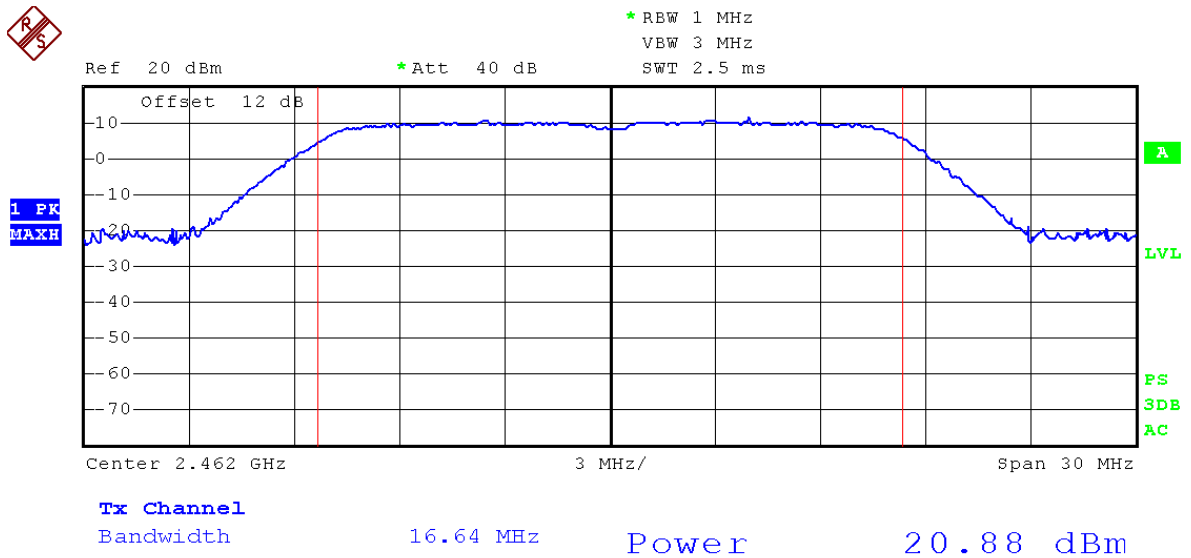

9. POWER SPECTRAL DENSITY

9.1 LIMITS

For digitally modulated systems, the power spectral density conducted from the intentional radiator to the antenna shall not be greater than 8 dBm in any 3 kHz band during any time interval of continuous transmission. This power spectral density shall be determined in accordance with the provisions of paragraph (b) of this section. The same method of determining the conducted output power shall be used to determine the power spectral density.

9.2 TEST PROCEDURES

Test procedures follow KDB 558074 D01 DTS Measurement Guidance v03r01.

1. Check the calibration of the measuring instrument using either an internal calibrator or a known signal from an external generator.
2. Position the EUT was set without connection to measurement instrument. Turn on the EUT and connect its antenna terminal to measurement instrument via a low loss cable. Then set it to any one measured frequency within its operating range, and make sure the instrument is operated in its linear range.
3. Set the analyzer span to 1.5 times the DTS bandwidth. Set the RBW = 3 kHz. Set the VBW ≥ 3 RBW. Detector = peak. Ensure that the number of measurement points in the sweep $\geq 2 \times \text{span}/\text{RBW}$ (use of a greater number of measurement points than this minimum requirement is recommended).
4. Repeat above procedures until all frequencies measured were complete.

9.3 TEST SETUP



9.4 TEST RESULTS

802.11b mode:

Channel No.	Frequency (MHz)	Mode	Data Rate	PSD (dBm/3KHz)	Limit	Result
1	2412	802.11b	11Mbps	-11.71	8dBm/3KHz	Pass
6	2437			-12.24		Pass
11	2462			-11.10		Pass

802.11b mode:
Channel 2412MHz

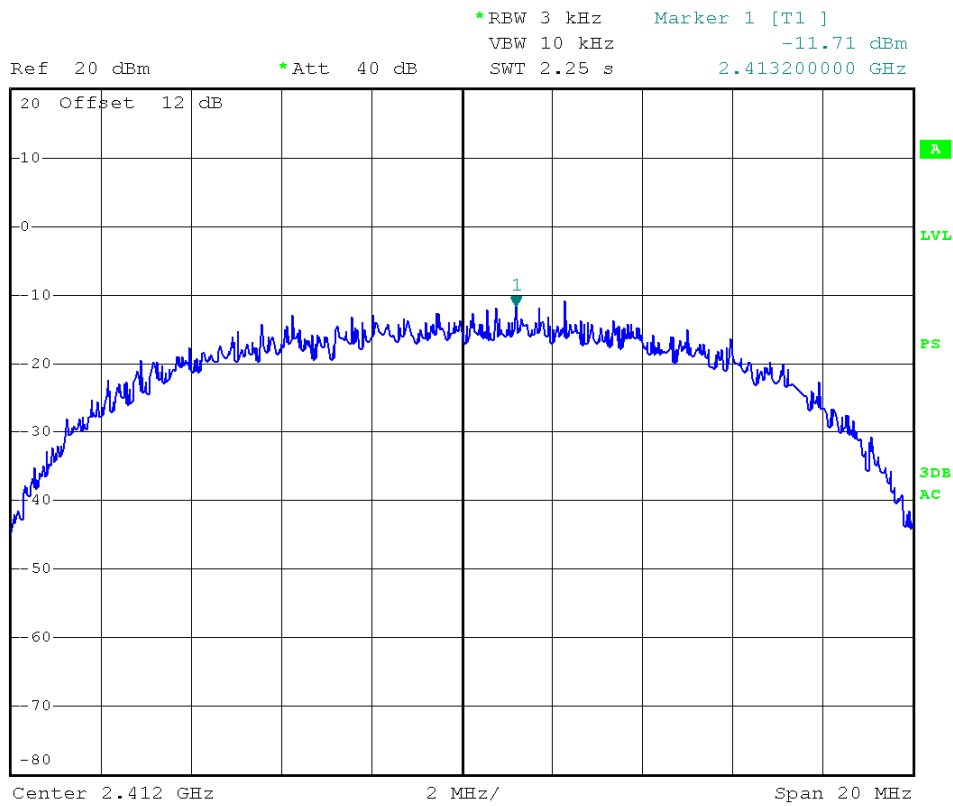

Channel 2437MHz



*RBW 3 kHz Marker 1 [T1]
VBW 10 kHz -12.24 dBm
SWT 2.25 s 2.438960000 GHz

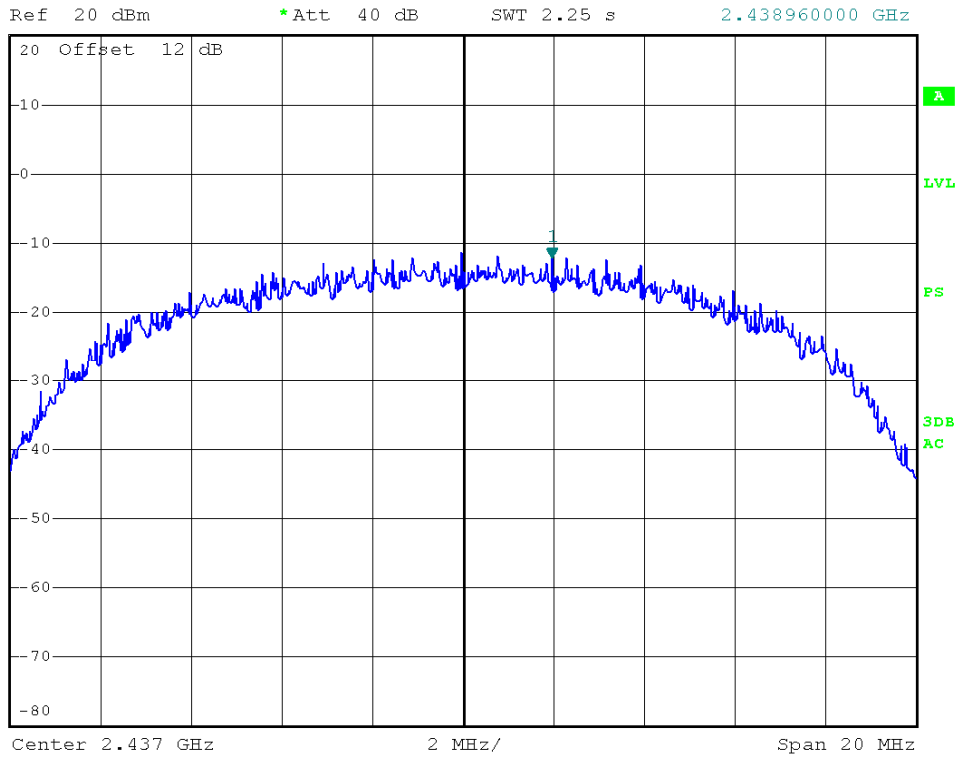

Channel 2462MHz



*RBW 3 kHz Marker 1 [T1]
VBW 10 kHz -11.10 dBm
SWT 2.25 s 2.461960000 GHz

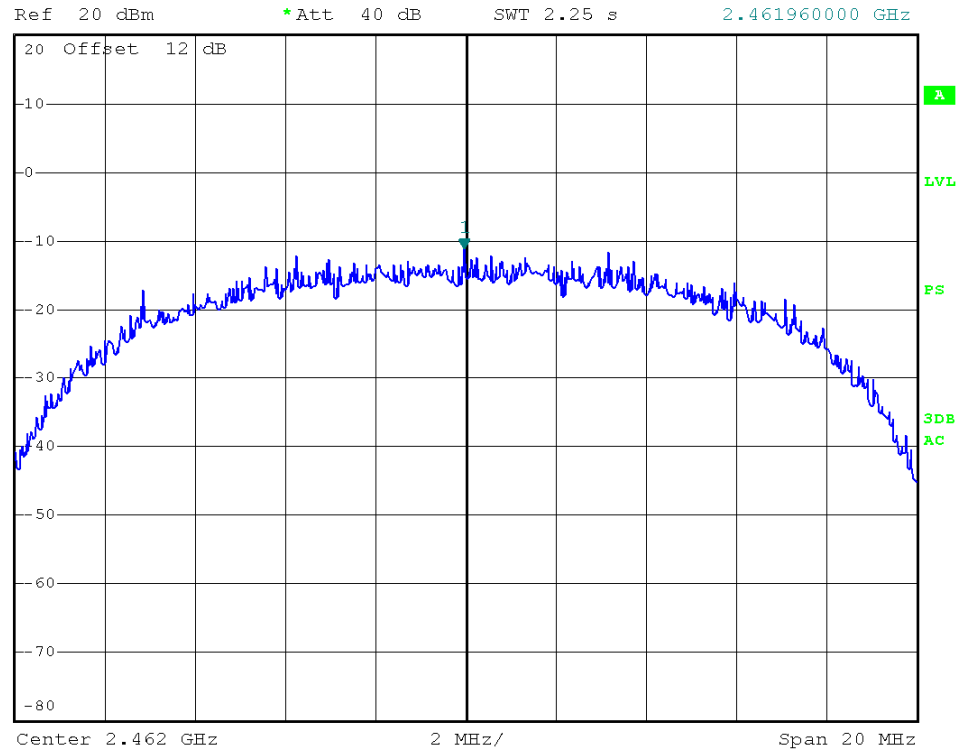

802.11g mode:

Channel No.	Frequency (MHz)	Mode	Data Rate	PSD (dBm/3KHz)	Limit	Result
1	2412	802.11g	54Mbps	-14.12	8dBm/3KHz	Pass
6	2437			-14.47		Pass
11	2462			-14.20		Pass

802.11g mode:
Channel 2412MHz

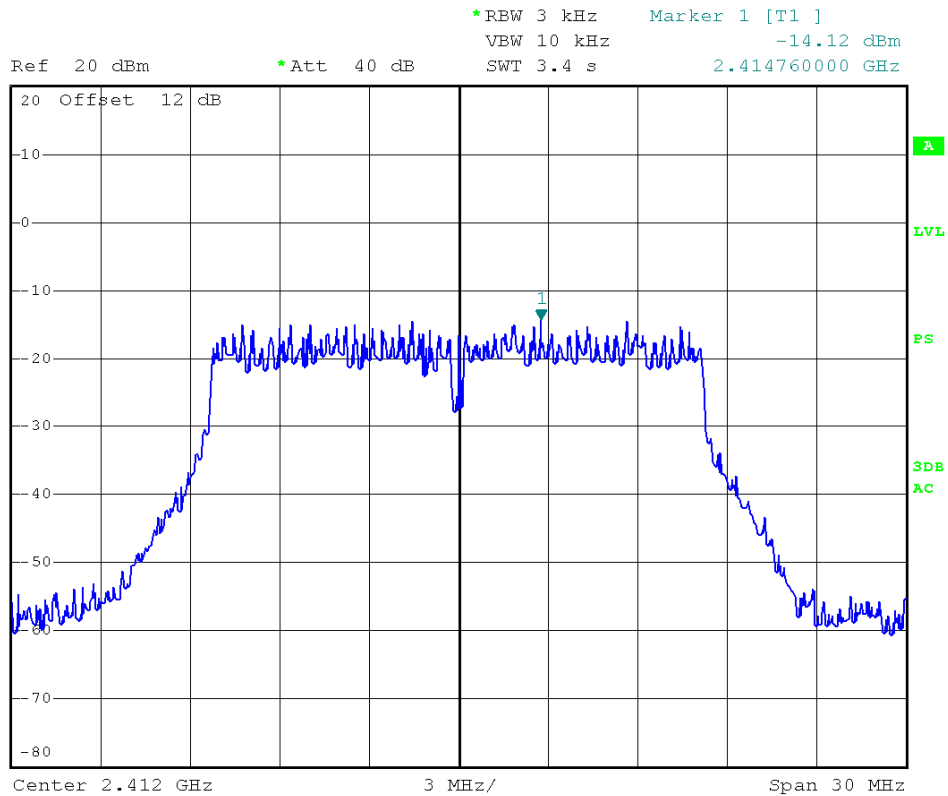

Channel 2437MHz



*RBW 3 kHz Marker 1 [T1]
VBW 10 kHz -14.47 dBm
SWT 3.4 s 2.435140000 GHz

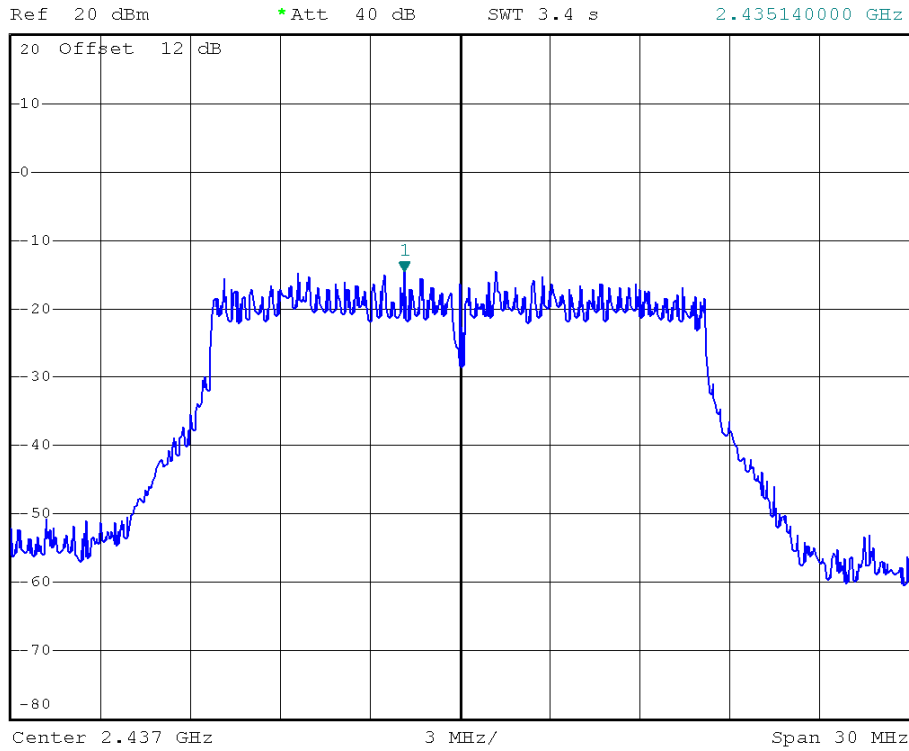

Channel 2462MHz



*RBW 3 kHz Marker 1 [T1]
VBW 10 kHz -14.20 dBm
SWT 3.4 s 2.464520000 GHz

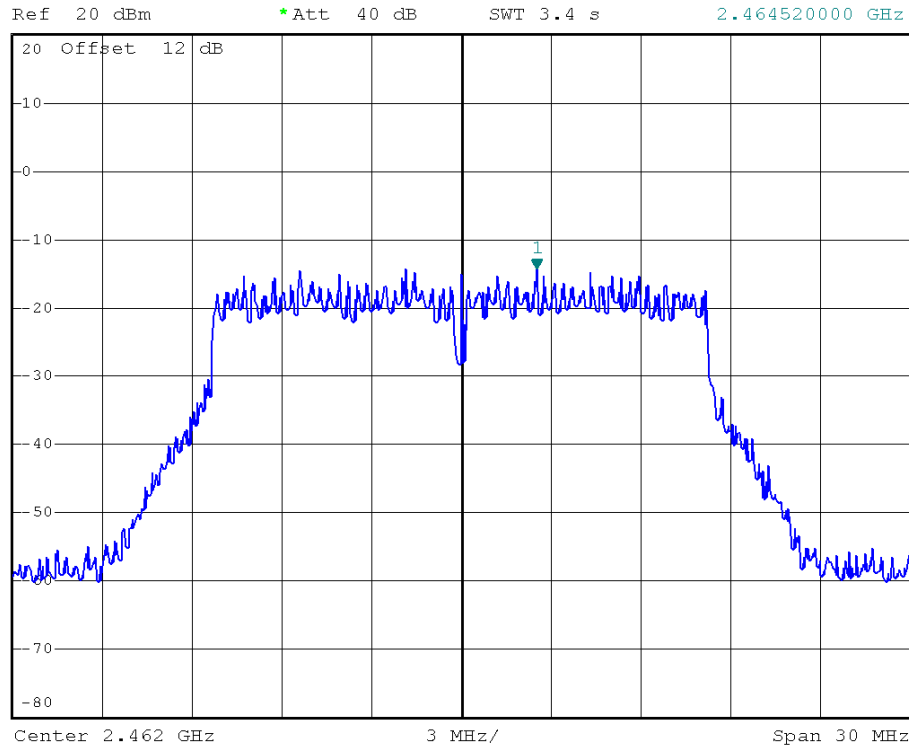

30M-1G

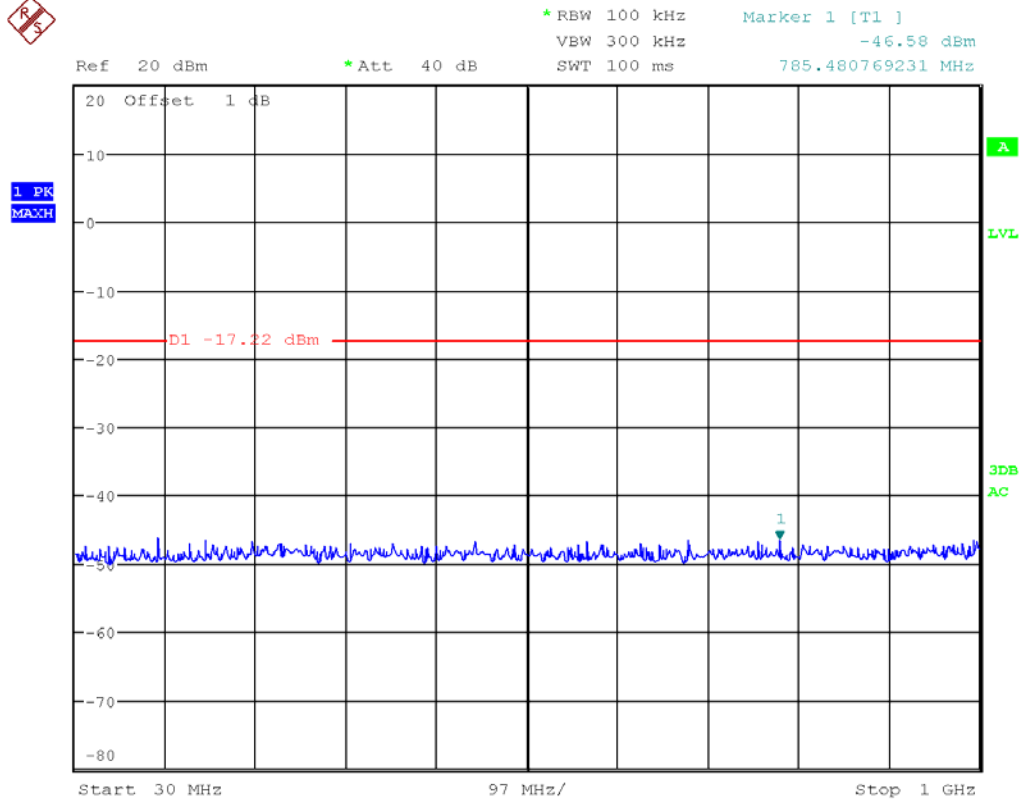

1G-10G

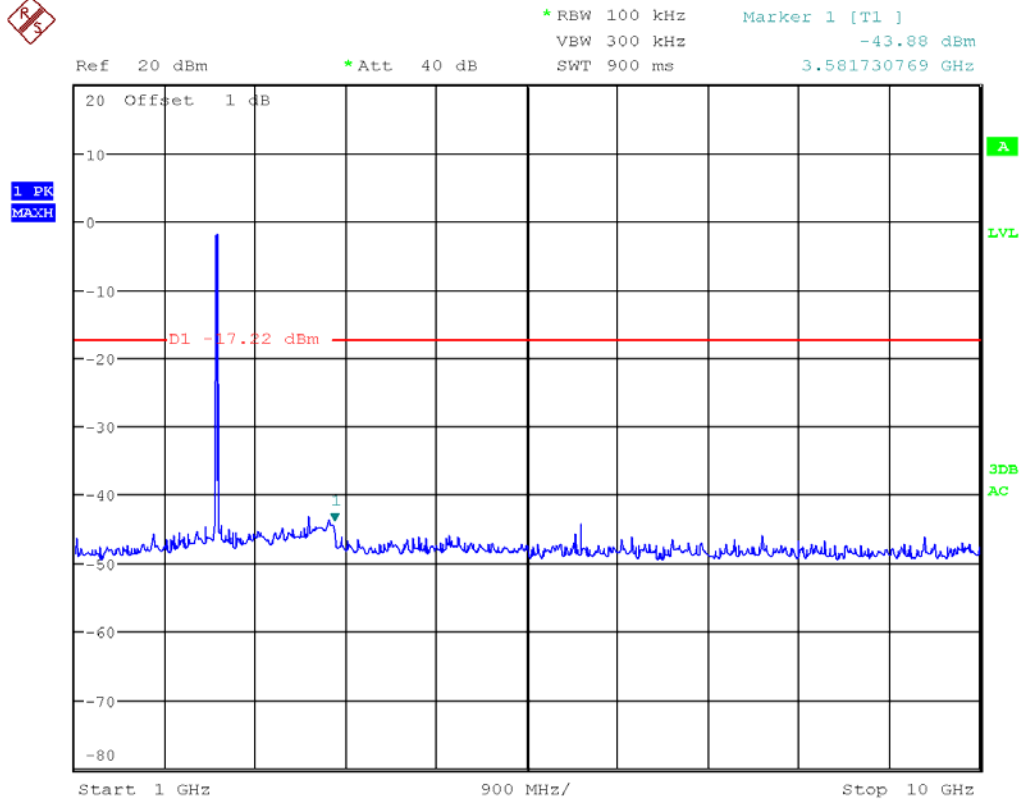

10G-25G

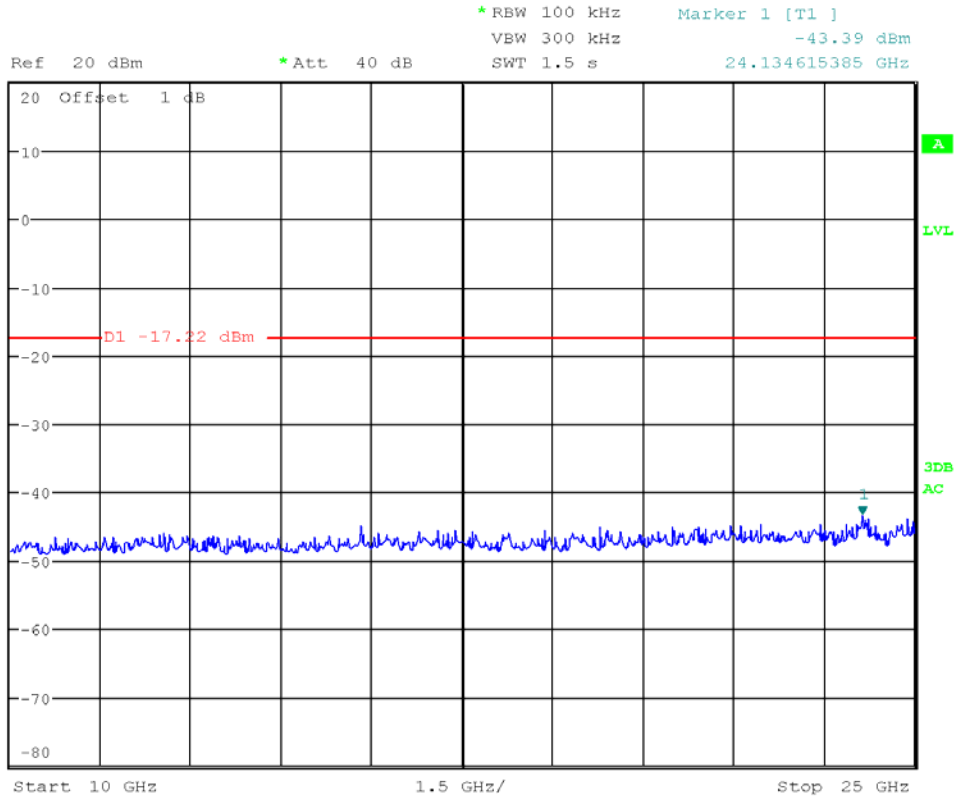

802.11b mode:
Channel 2437MHz
Reference level

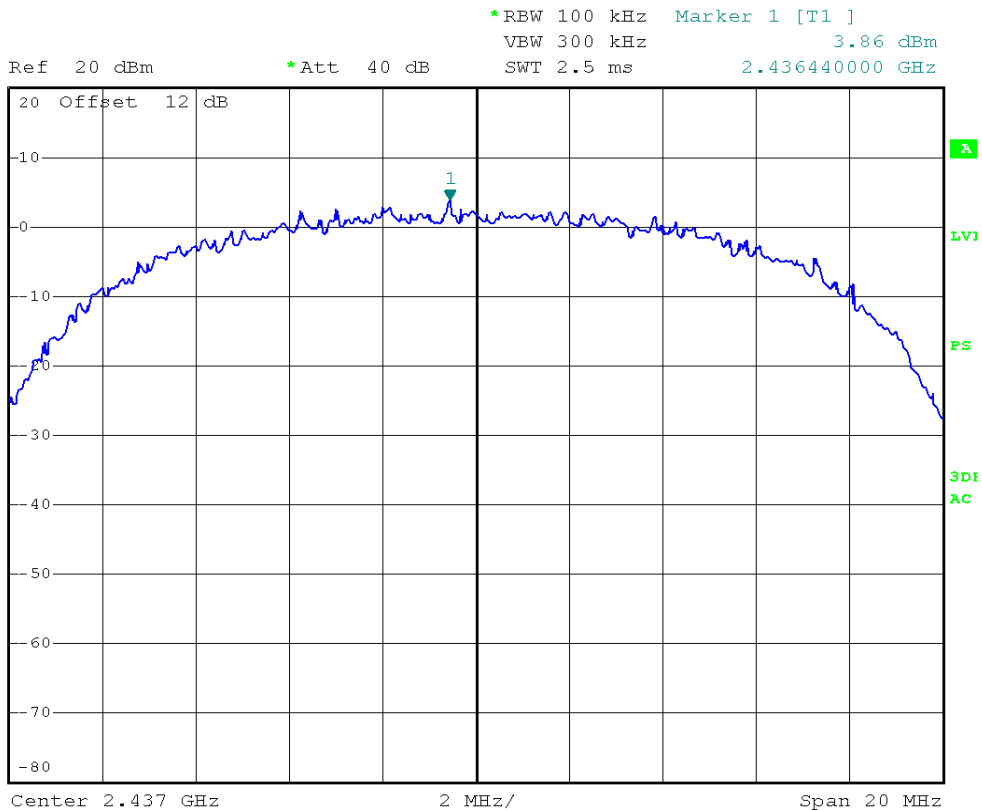

30M-1G



Ref 20 dBm *Att 40 dB *RBW 100 kHz Marker 1 [T1]
VBW 300 kHz -44.46 dBm
SWT 100 ms 281.826923077 MHz

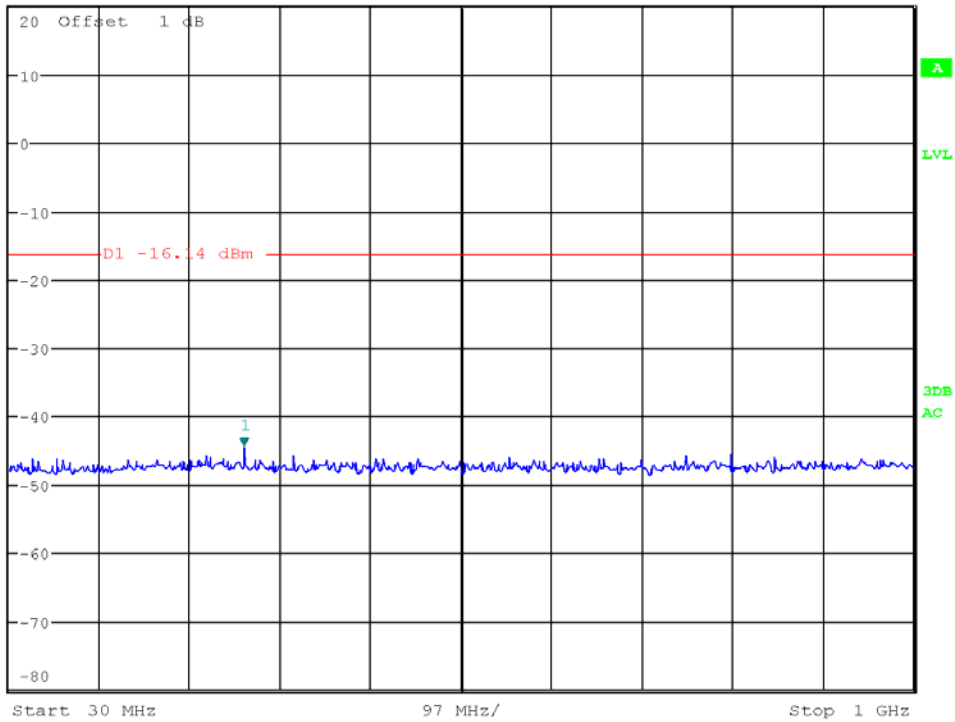

1G-10G



Ref 20 dBm *Att 40 dB *RBW 100 kHz Marker 1 [T1]
VBW 300 kHz -43.07 dBm
SWT 900 ms 3.509615385 GHz

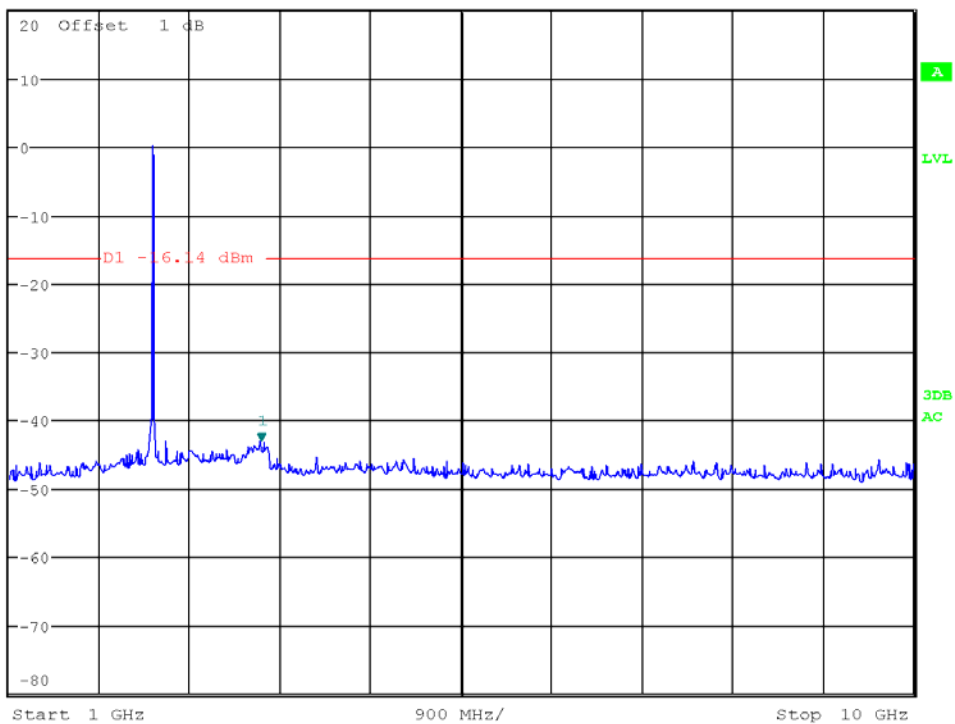

10-25G

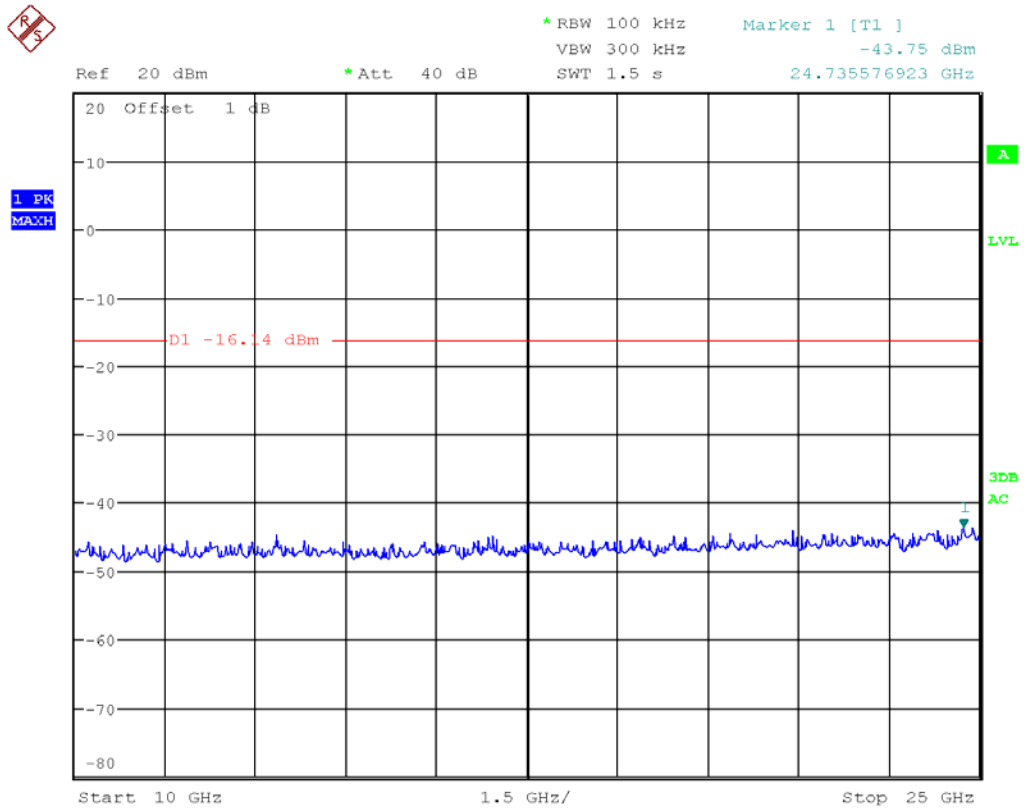

802.11b mode:
Channel 2462MHz
Reference level

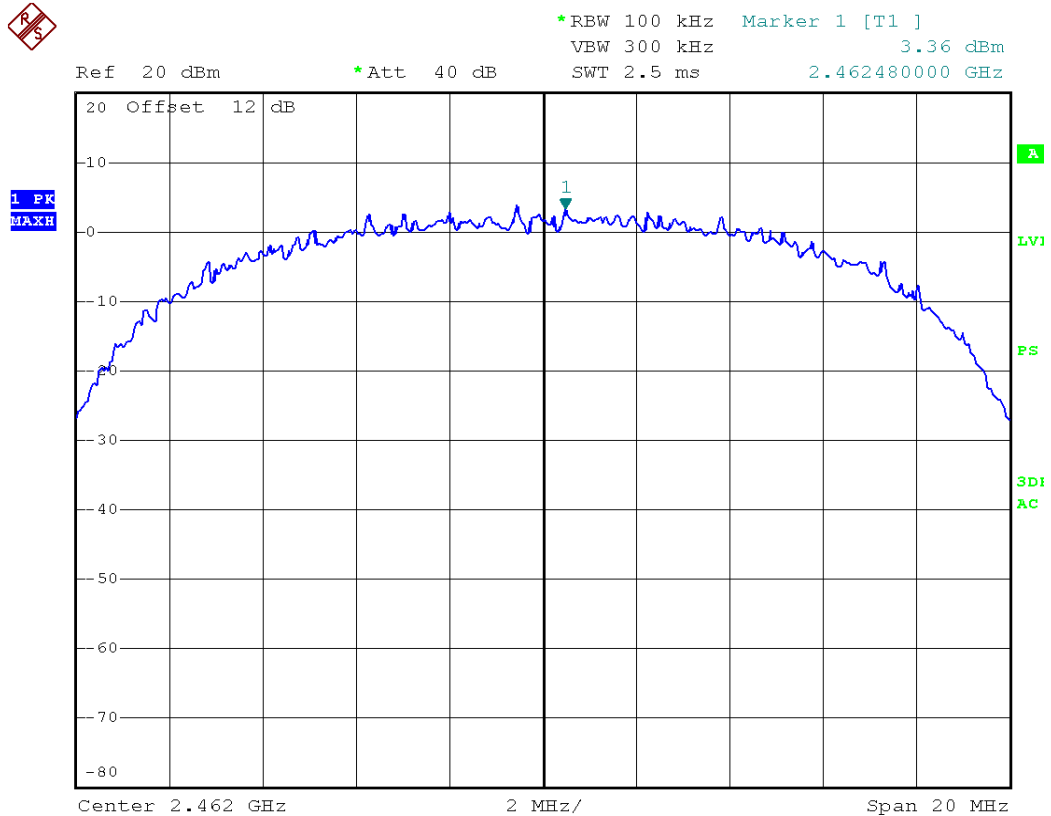

30M-1G

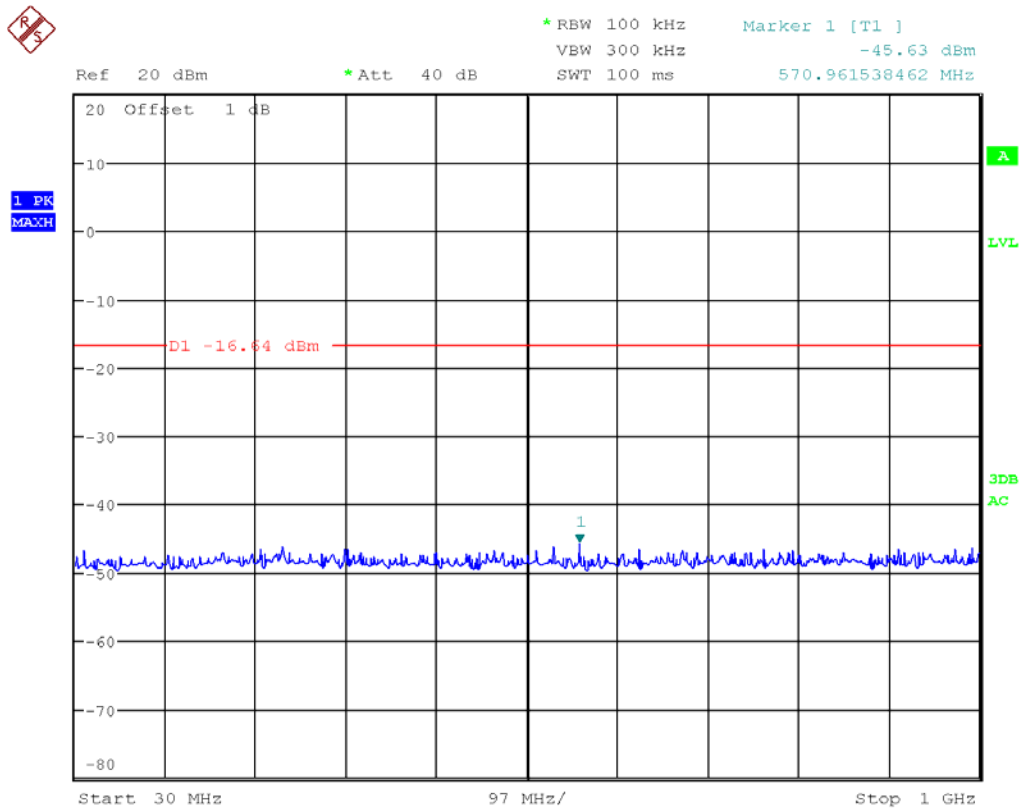

1G-10G

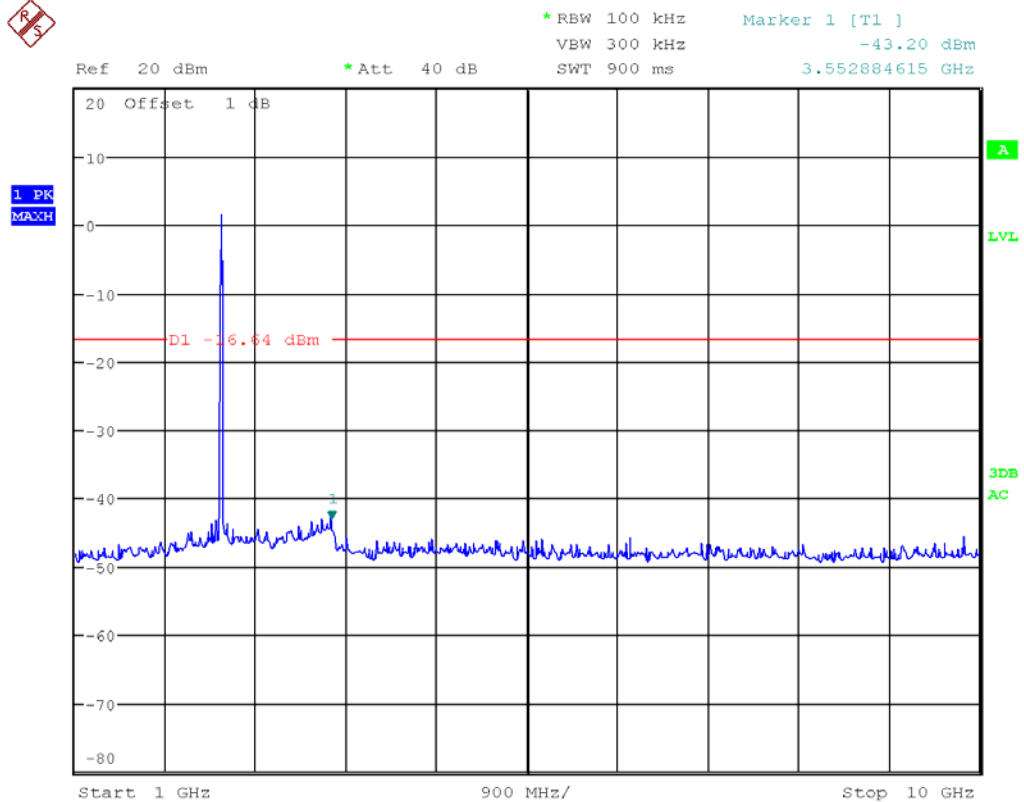

10G-25G



*RBW 100 kHz Marker 1 [T1]
VBW 300 kHz -43.64 dBm
SWT 1.5 s 18.846153846 GHz

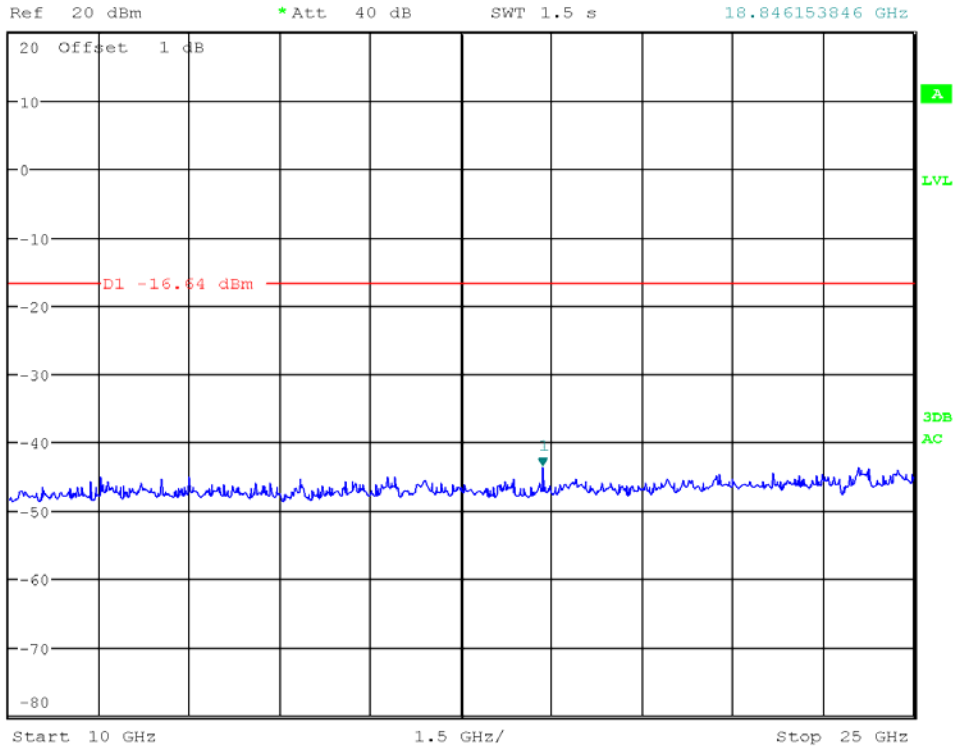

802.11G mode:
Channel 2412MHz
Reference level

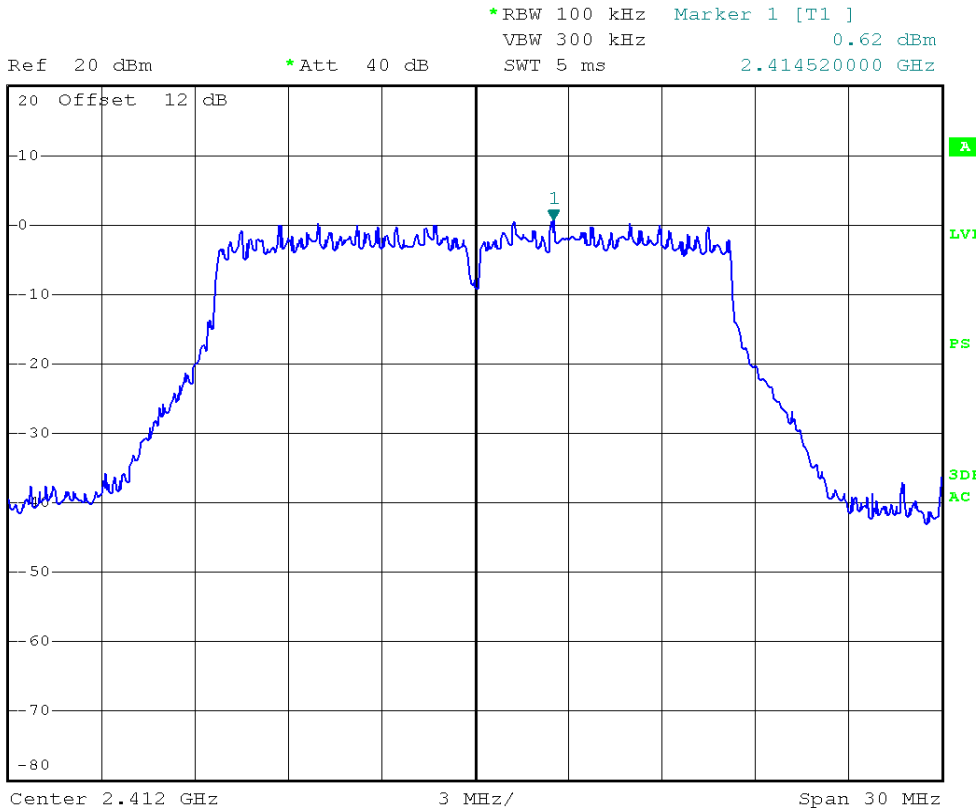

30M-1G

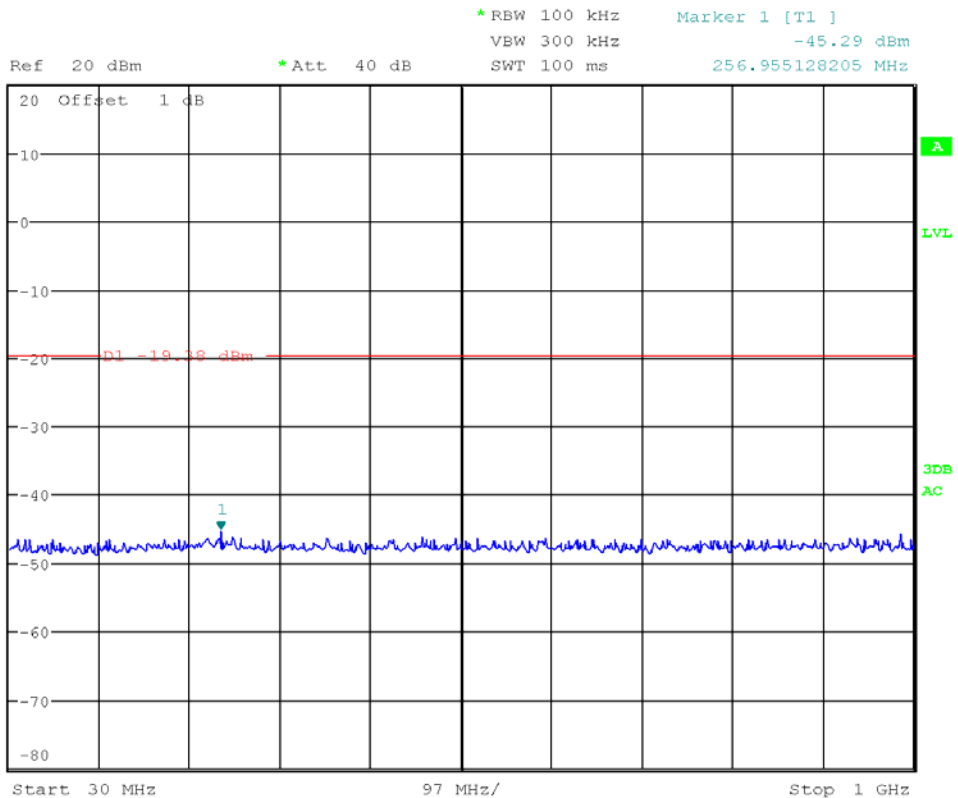

1G-10G

1G-10G



Ref 20 dBm *Att 40 dB *RBW 100 kHz Marker 1 [T1]
VBW 300 kHz -41.61 dBm
SWT 900 ms 3.552884615 GHz

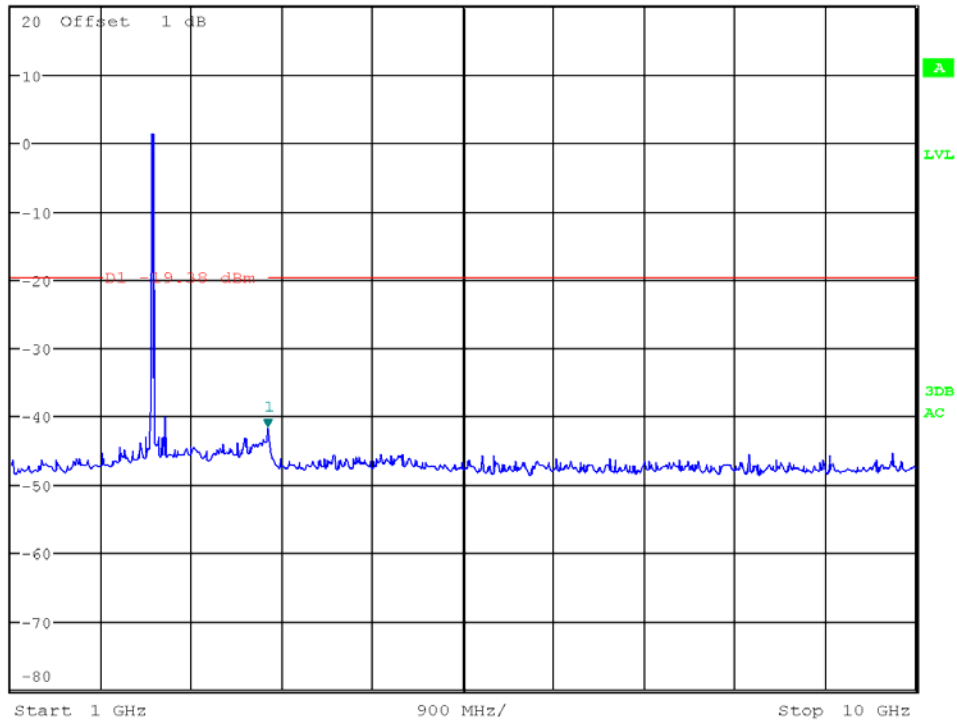

10G-25G



Ref 20 dBm *Att 40 dB *RBW 100 kHz Marker 1 [T1]
VBW 300 kHz -44.13 dBm
SWT 1.5 s 24.639423077 GHz

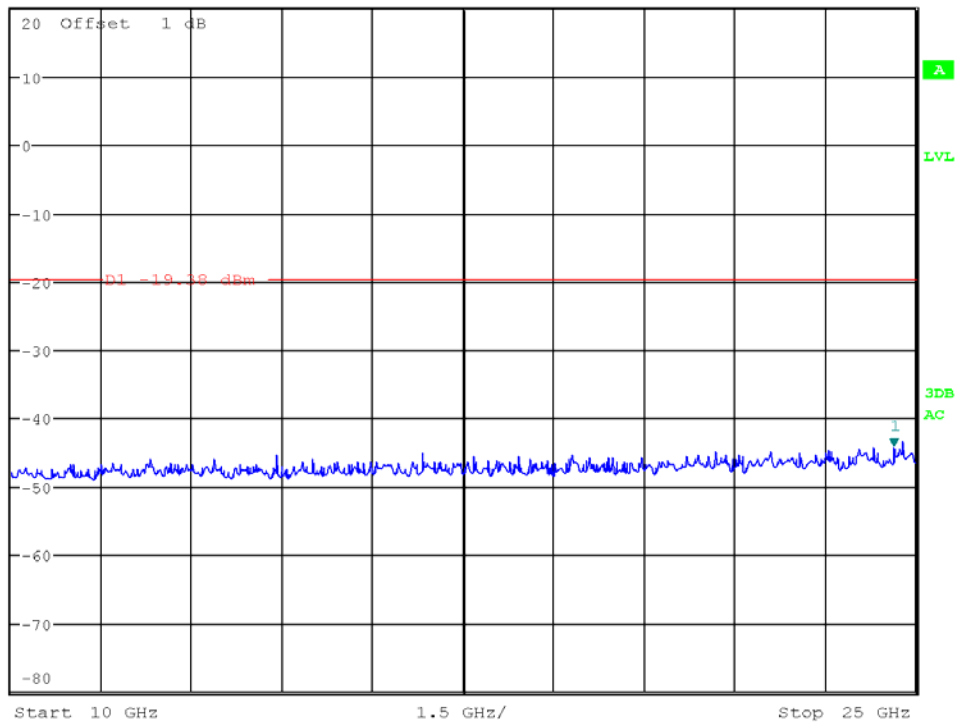

802.11G mode:
Channel 2437MHz
Reference level

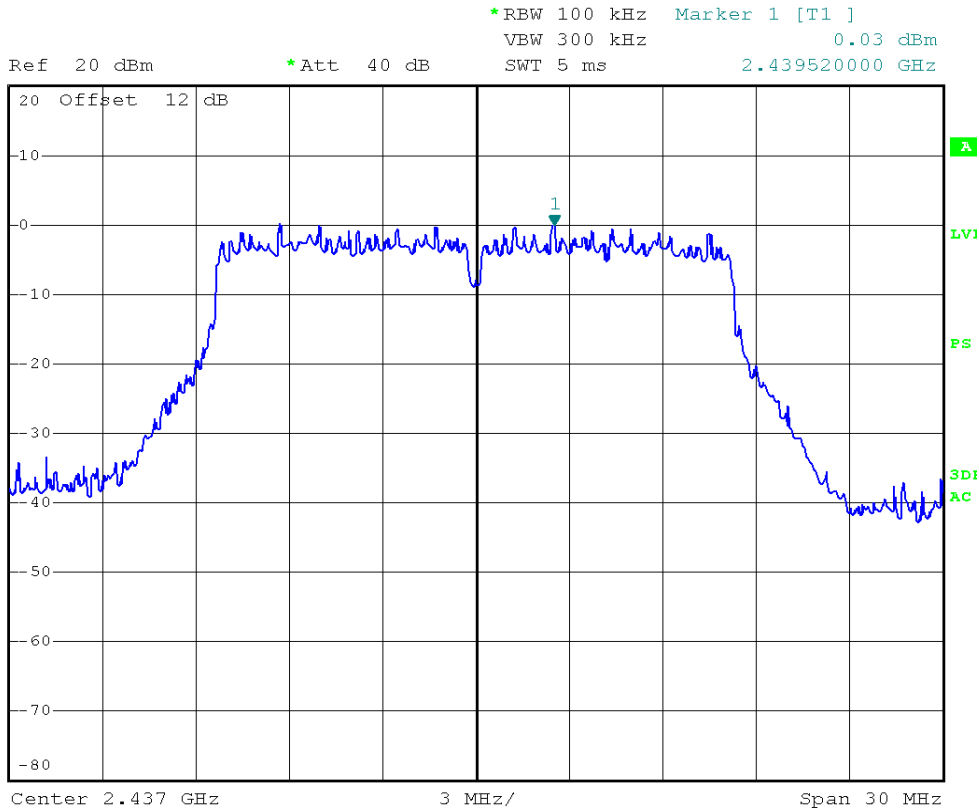

30M-1G

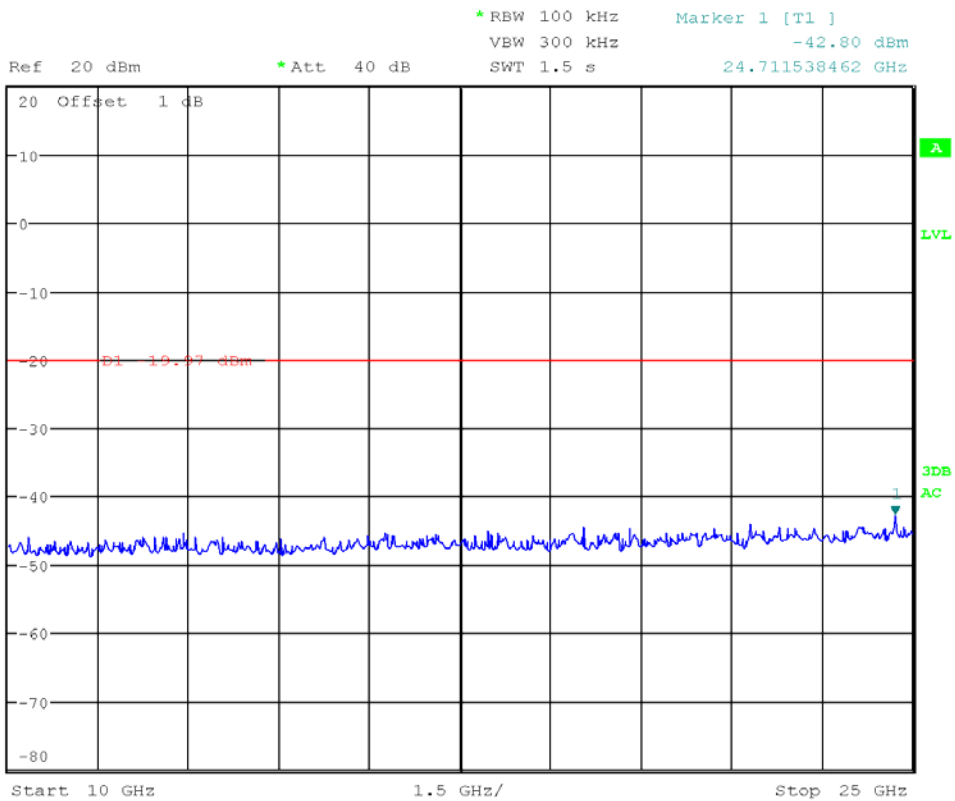

1G-10G

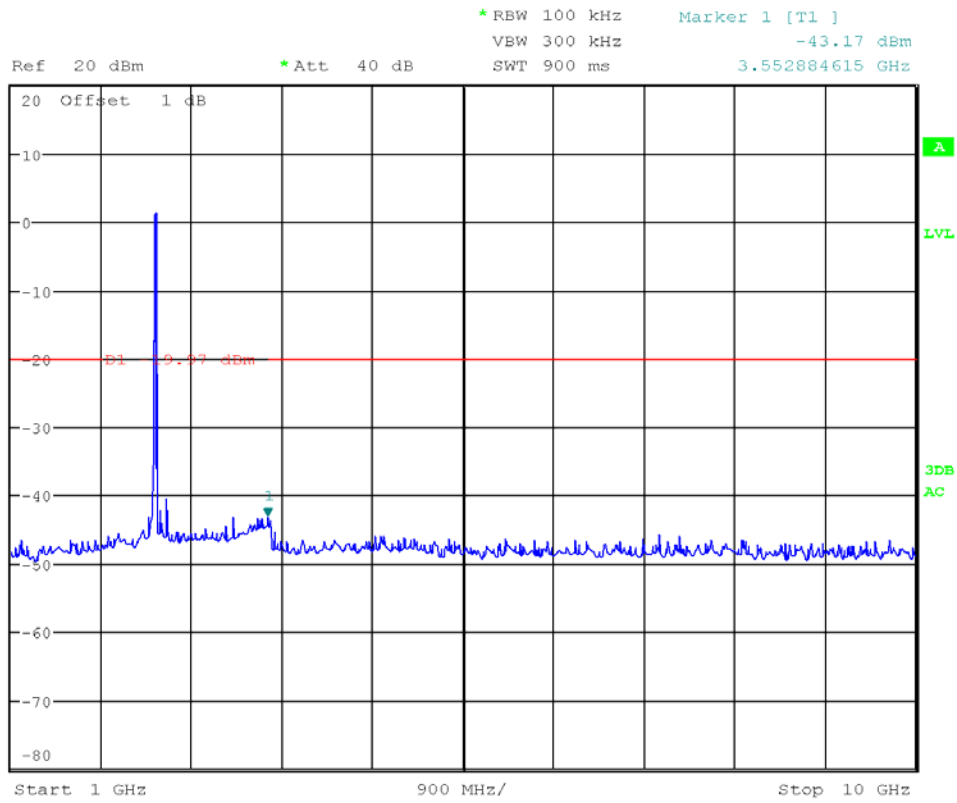

10G-25G

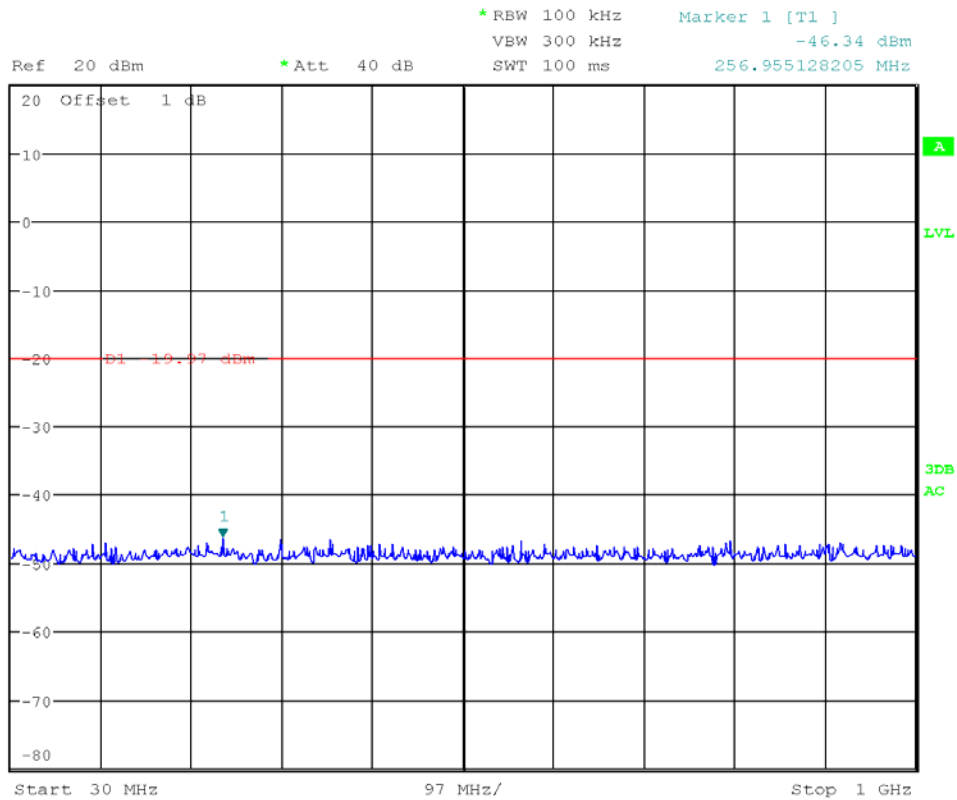

802.11G mode:
Channel 2462MHz
Reference level

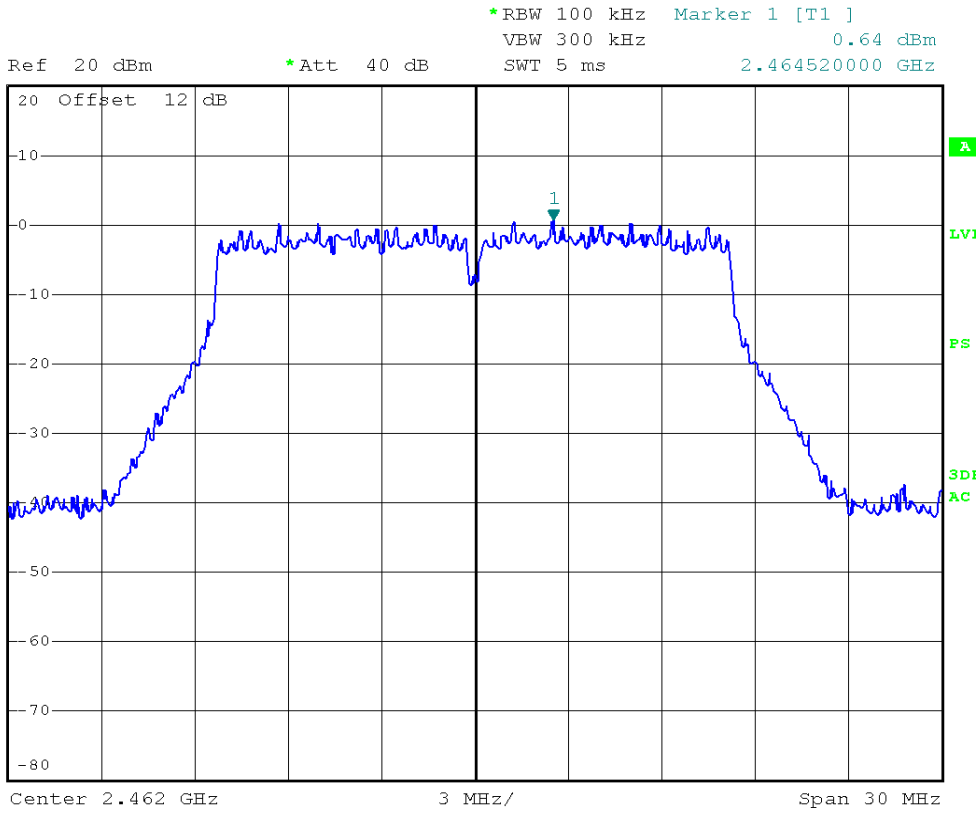

Channel 2462MHz
30M-1G

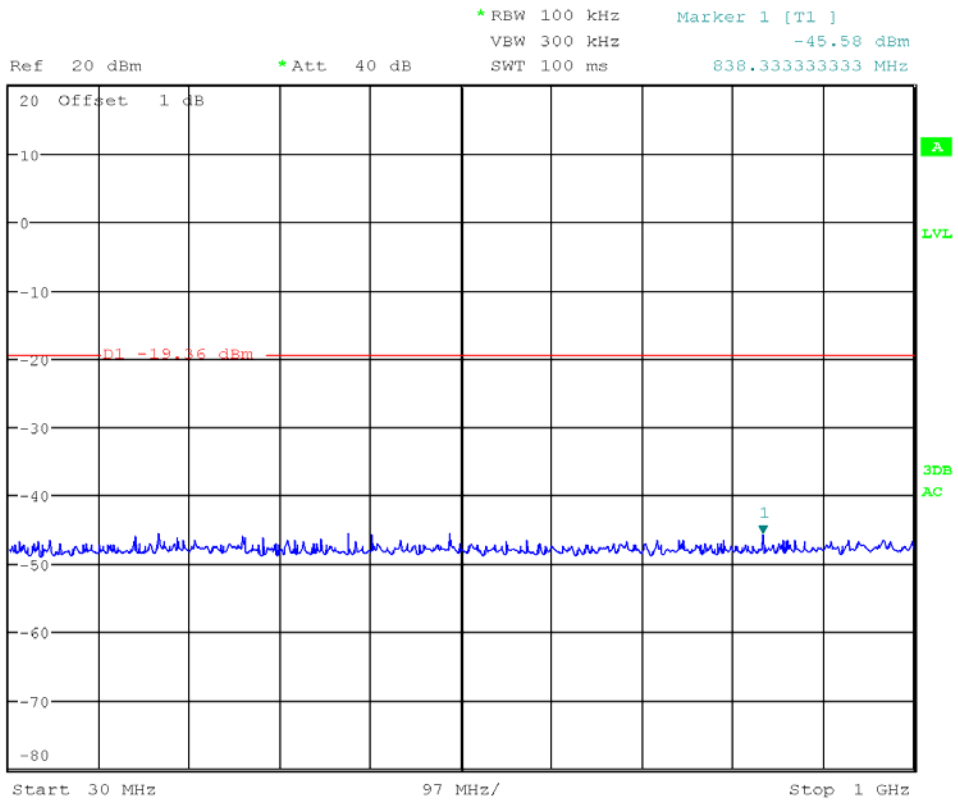

1G-10G

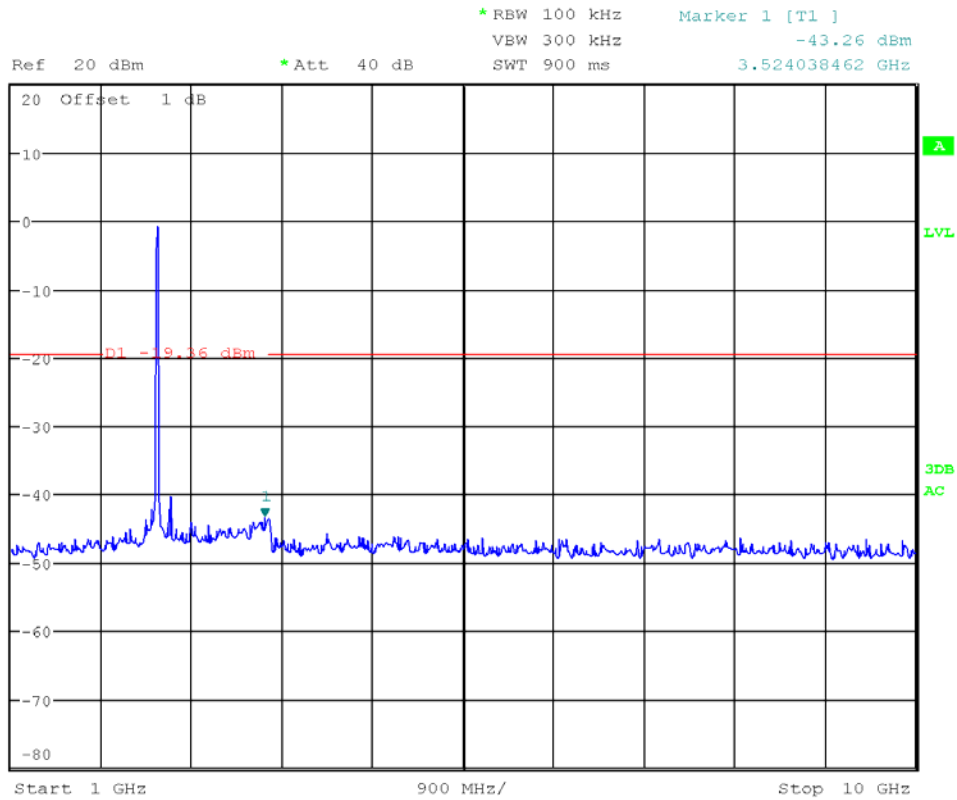

10G-25G

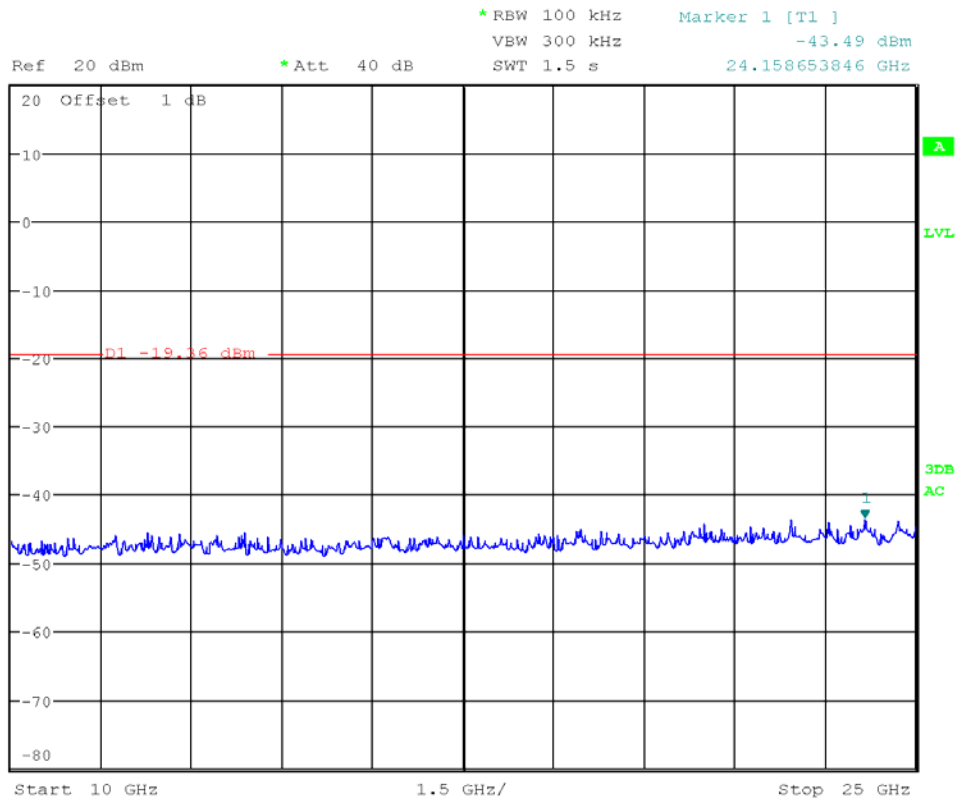

11. EMISSIONS IN RESTRICTED FREQUENCY BANDS

11.1 LIMITS

The DTS rules specify that emissions which fall into restricted frequency bands shall comply with the general radiated emission limits..

11.2 TEST PROCEDURES

Test procedures follow KDB 558074 D01 DTS Meas Guidance v03r01.

1. Check the calibration of the measuring instrument using either an internal calibrator or a known signal from an external generator.
2. Position the EUT without connection to measurement instrument. Turn on the EUT and connect its antenna terminal to measurement instrument via a low loss cable. Then set it to any one measured frequency within its operating range, and make sure the instrument is operated in its linear range.
3. Set the analyzer span to encompass the entire unwanted emission bandwidth above the measurement system noise level.
4. When Detector = peak, Set the RBW = 1 MHz. Set the VBW \geq 3 MHz. Ensure that the number of measurement points in the sweep \geq 2 x (span/RBW). Set sweep time = auto couple. When Detector = average. Set the RBW = 1 MHz. Set the VBW = 10Hz. Ensure that the number of measurement points in the sweep \geq 2 x (span/RBW). Set sweep time = auto couple. Employ trace averaging over a minimum of 100 traces.
5. Use the peak marker function to determine the maximum average power level in any 1 MHz of the unwanted emission.
6. Repeat above procedures until all measured frequencies were complete.

11.3 TEST SETUP

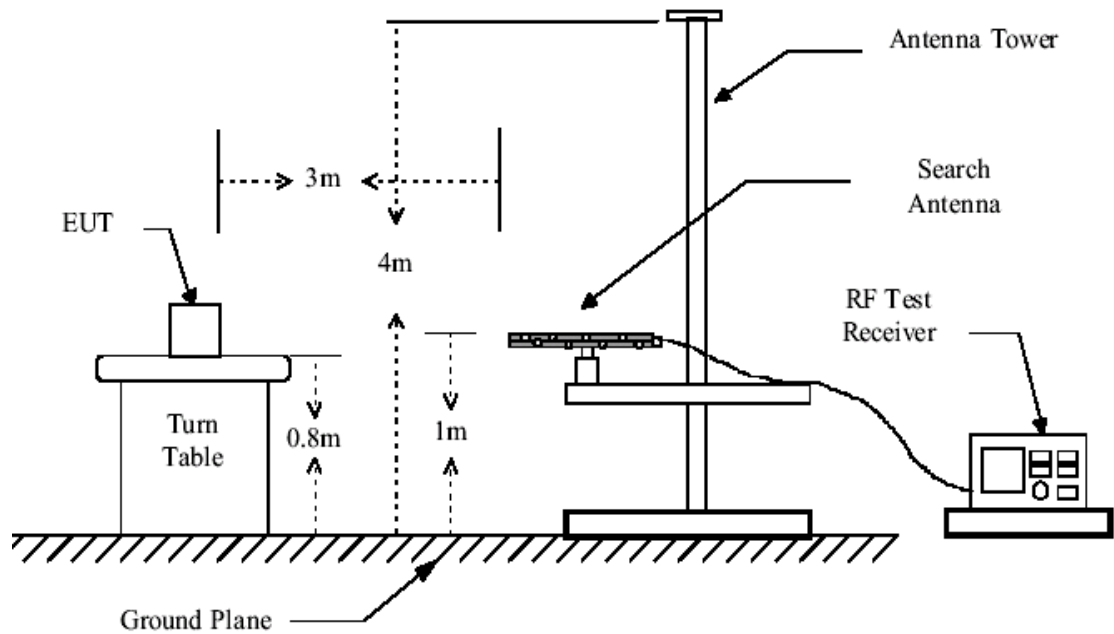

Figure 1. 30MHz to 1GHz radiated emissions test configuration

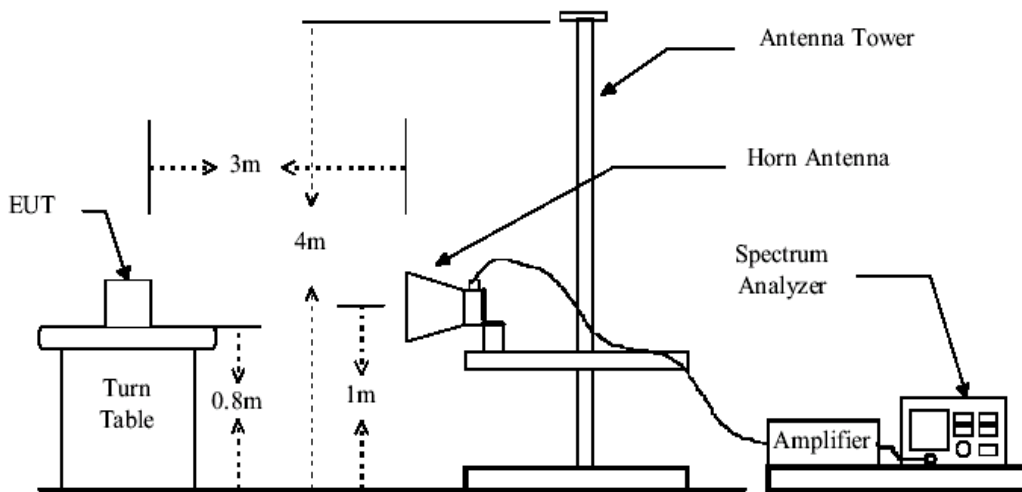
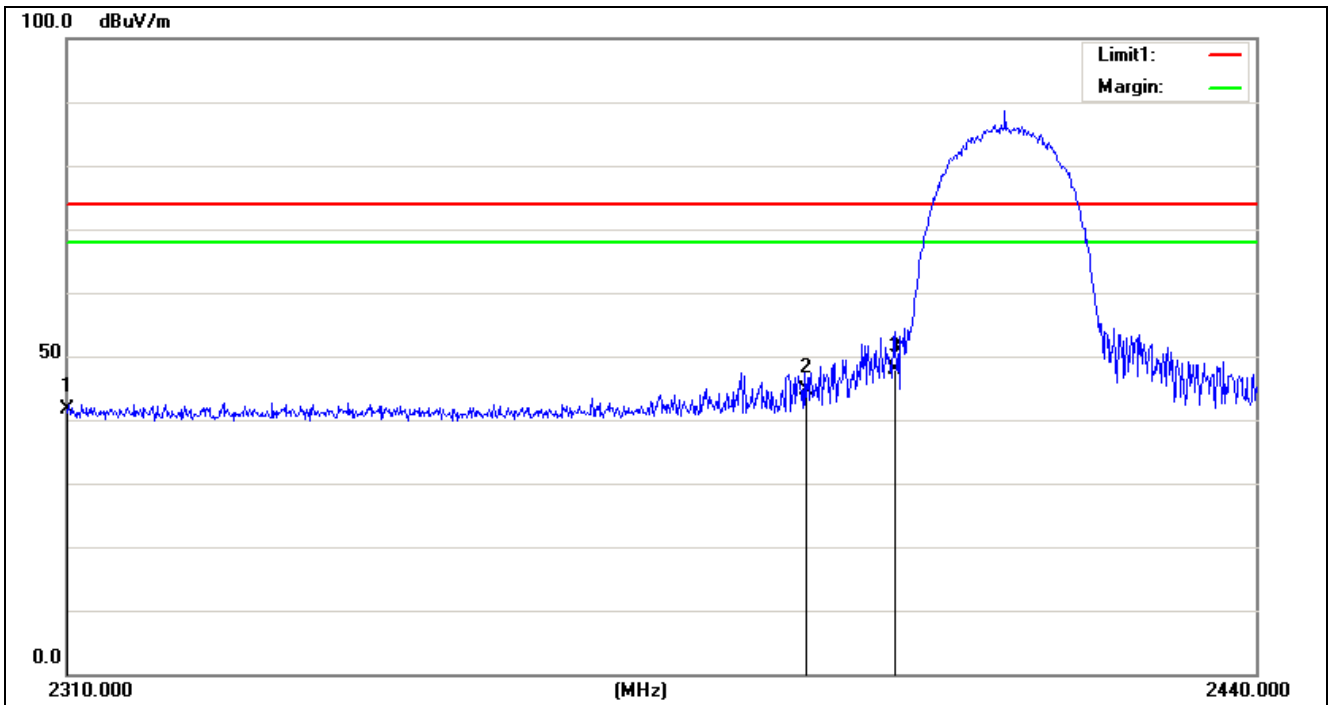

Figure 2. Above 1GHz radiated emissions test configuration

11.4 TEST RESULTS

Project No.:	ZJ00032008	Polarziation:	Vertical
Standard:	(RE)FCC PART 15 class B 3m_PEAK	Power Source:	
Test item:	Radiation Test	Date:	2013-9-25
Temp./Hum.(%RH):	20/54%RH	Time:	11:56:11
EUT:	JBL AUTHENTICS L16	Distance:	3m
Model:	B-2412	Test Result:	Pass
Note:			



No.	Frequency (MHz)	Reading (dBuV/m)	Correct Factor(dB/m)	Result (dBuV/m)	Limit (dBuV/m)	Margin (dB)	Remark
1	2310.000	30.90	10.63	41.53	74.00	-32.47	peak
2	2390.000	32.88	11.64	44.52	74.00	-29.48	peak
3	2400.000	35.97	11.90	47.87	74.00	-26.13	peak

Project No.:	ZJ00032008	Polarziation:	Vertical
Standard:	(RE)FCC PART 15 class B 3m_AVG	Power Source:	
Test item:	Radiation Test	Date:	2013-9-25
Temp./Hum.(%RH):	20/54%RH	Time:	11:57:51
EUT:	JBL AUTHENTICS L16	Distance:	3m
Model:	B-2412	Test Result:	Pass
Note:			

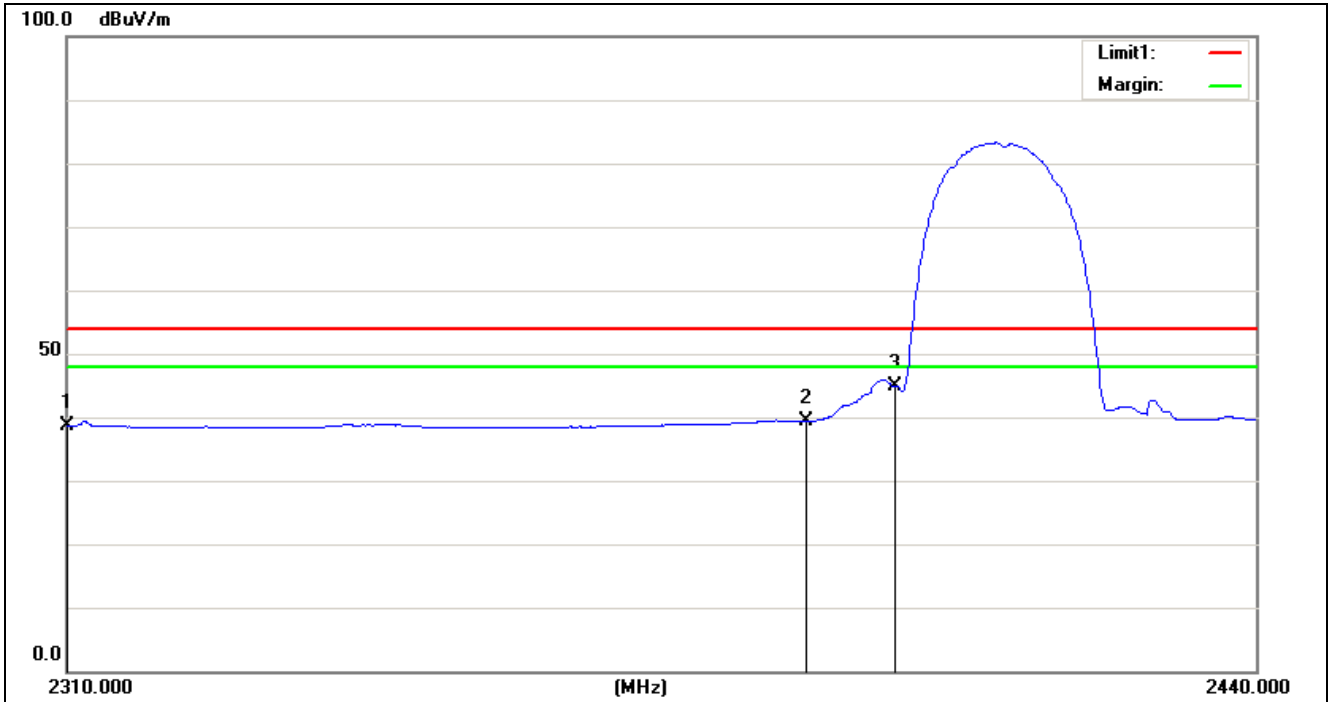

No.	Frequency (MHz)	Reading (dBuV/m)	Correct Factor(dB/m)	Result (dBuV/m)	Limit (dBuV/m)	Margin (dB)	Remark
1	2310.000	28.07	10.63	38.70	54.00	-15.30	AVG
2	2390.000	27.73	11.64	39.37	54.00	-14.63	AVG
3	2400.000	33.00	11.90	44.90	54.00	-9.10	AVG

Project No.:	ZJ00032008	Polarziation:	Horizontal
Standard:	(RE)FCC PART 15 class B 3m_PEAK	Power Source:	
Test item:	Radiation Test	Date:	2013-9-25
Temp./Hum.(%RH):	20/54%RH	Time:	12:00:11
EUT:	JBL AUTHENTICS L16	Distance:	3m
Model:	B-2412	Test Result:	Pass
Note:			

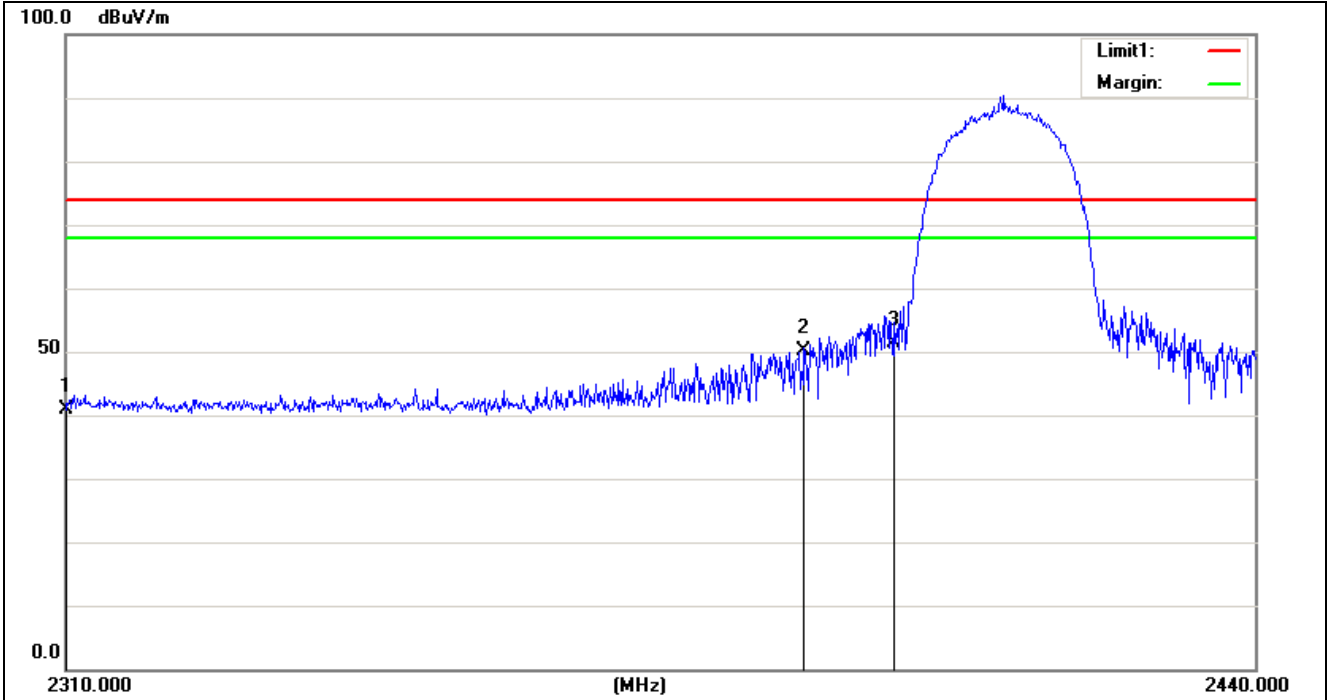

No.	Frequency (MHz)	Reading (dBuV/m)	Correct Factor(dB/m)	Result (dBuV/m)	Limit (dBuV/m)	Margin (dB)	Remark
1	2310.000	30.16	10.63	40.79	74.00	-33.21	peak
2	2390.000	38.52	11.64	50.16	74.00	-23.84	peak
3	2400.000	39.46	11.90	51.36	74.00	-22.64	peak

Project No.:	ZJ00032008	Polarziation:	Horizontal
Standard:	(RE)FCC PART 15 class B 3m_AVG	Power Source:	
Test item:	Radiation Test	Date:	2013-9-25
Temp./Hum.(%RH):	20/54%RH	Time:	11:59:00
EUT:	JBL AUTHENTICS L16	Distance:	3m
Model:	B-2412	Test Result:	Pass
Note:			

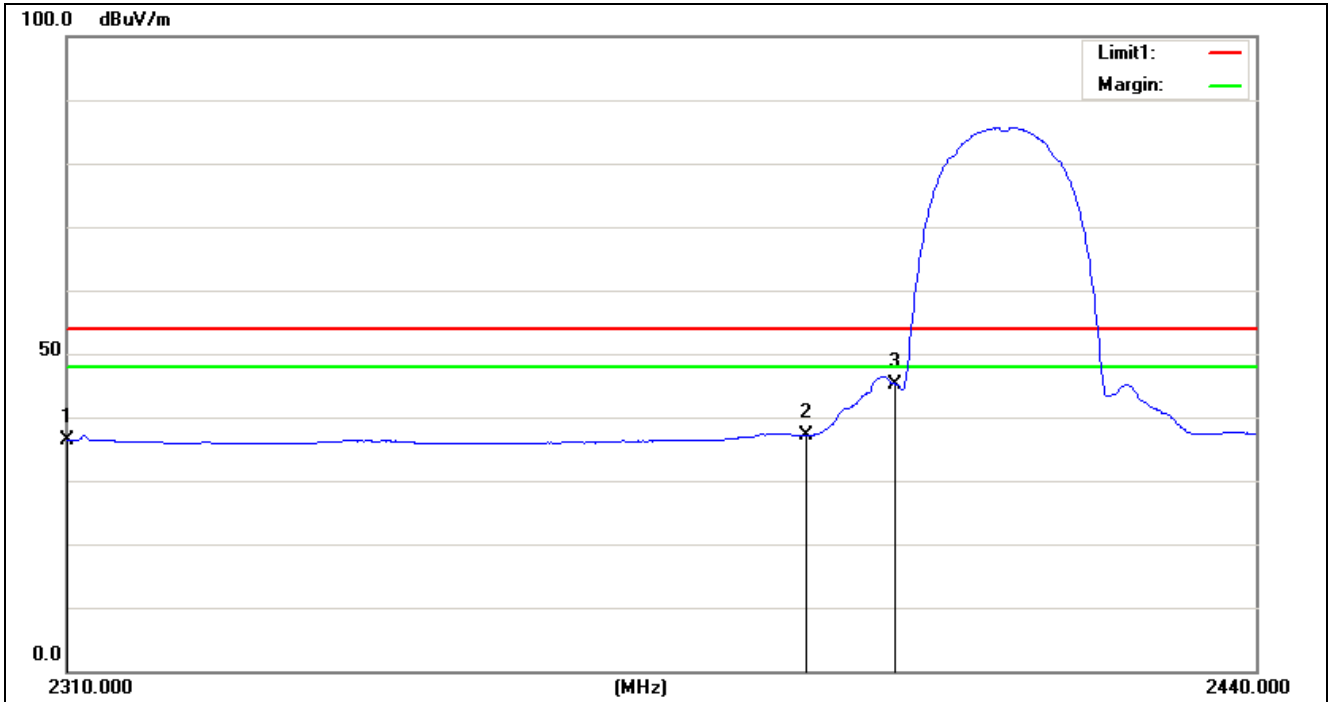

No.	Frequency (MHz)	Reading (dBuV/m)	Correct Factor(dB/m)	Result (dBuV/m)	Limit (dBuV/m)	Margin (dB)	Remark
1	2310.000	25.72	10.63	36.35	54.00	-17.65	AVG
2	2390.000	25.48	11.64	37.12	54.00	-16.88	AVG
3	2400.000	33.31	11.90	45.21	54.00	-8.79	AVG

Project No.:	ZJ00032008	Polarziation:	Vertical
Standard:	(RE)FCC PART 15 class B 3m_PEAK	Power Source:	
Test item:	Radiation Test	Date:	2013-9-25
Temp./Hum.(%RH):	20/54%RH	Time:	12:04:15
EUT:	JBL AUTHENTICS L16	Distance:	3m
Model:	B-2462	Test Result:	Pass
Note:			

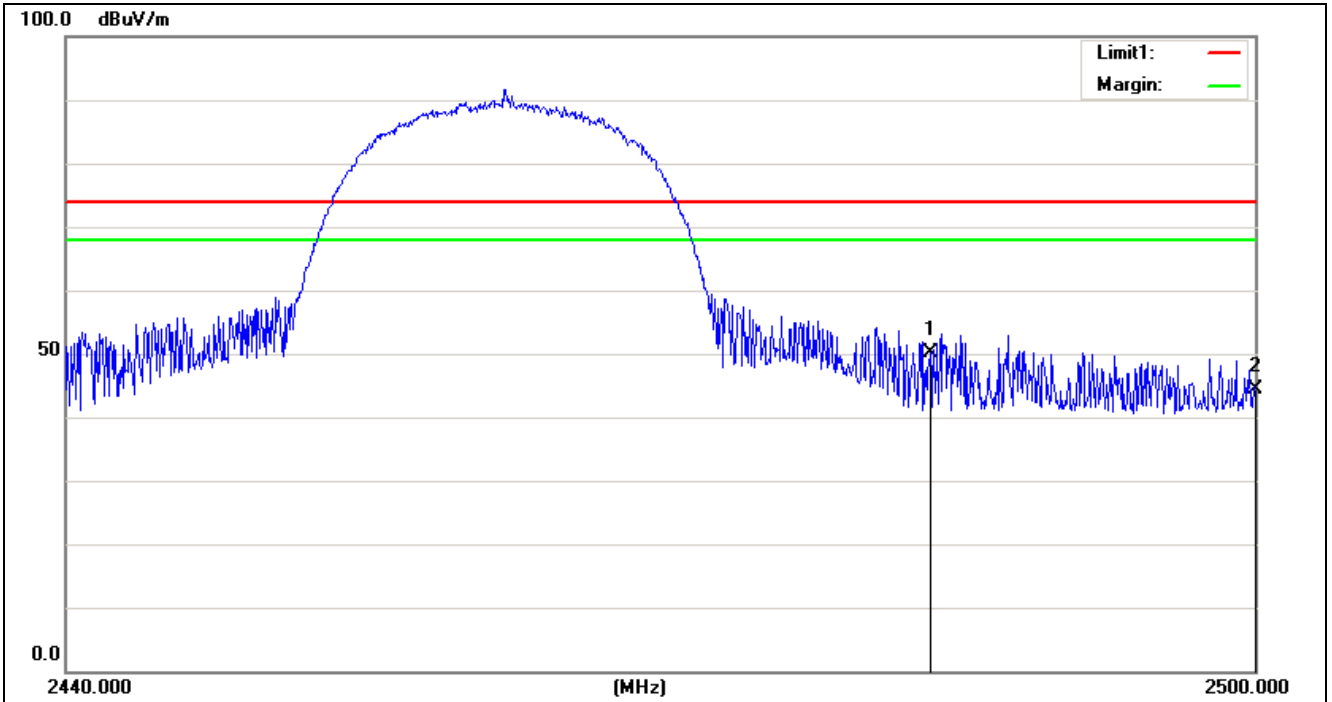

No.	Frequency (MHz)	Reading (dBuV/m)	Correct Factor(dB/m)	Result (dBuV/m)	Limit (dBuV/m)	Margin (dB)	Remark
1	2483.500	38.56	11.61	50.17	74.00	-23.83	peak
2	2500.000	32.96	11.51	44.47	74.00	-29.53	peak

Project No.:	ZJ00032008	Polarziation:	Vertical
Standard:	(RE)FCC PART 15 class B 3m_AVG	Power Source:	
Test item:	Radiation Test	Date:	2013-9-25
Temp./Hum.(%RH):	20/54%RH	Time:	12:05:33
EUT:	JBL AUTHENTICS L16	Distance:	3m
Model:	B-2462	Test Result:	Pass
Note:			

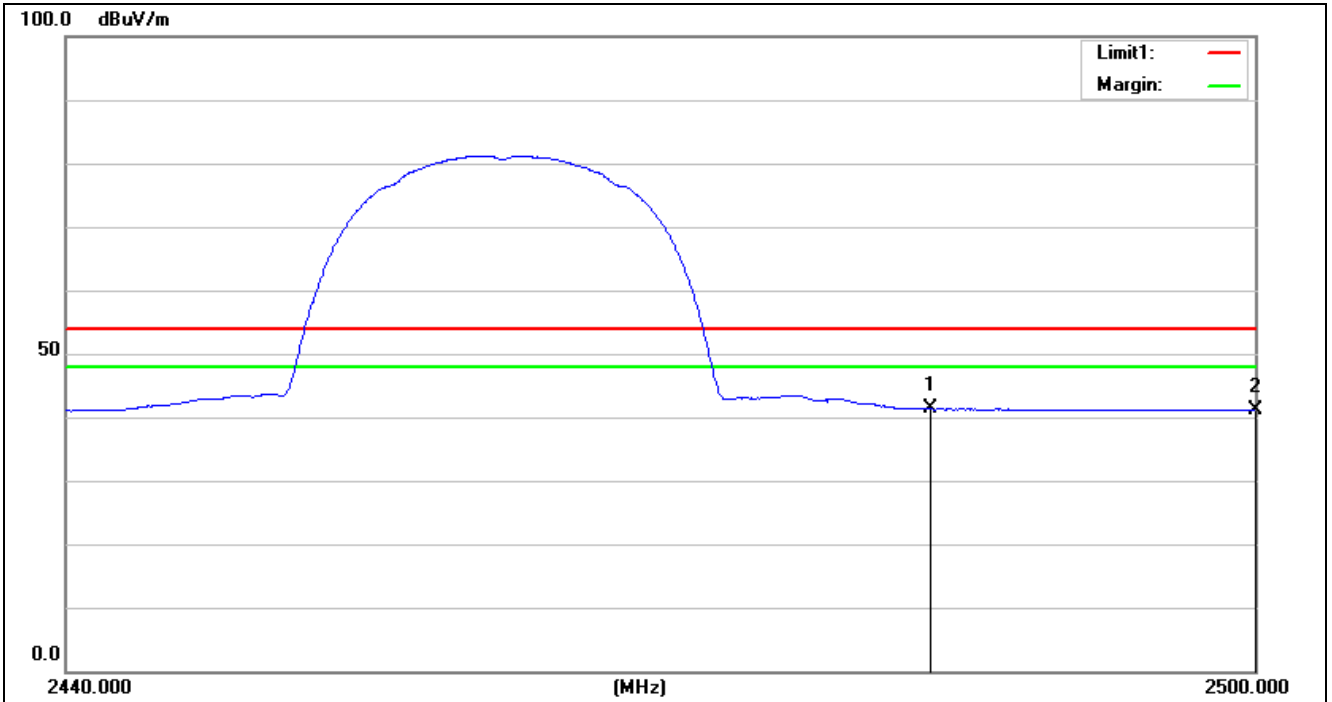

No.	Frequency (MHz)	Reading (dBuV/m)	Correct Factor(dB/m)	Result (dBuV/m)	Limit (dBuV/m)	Margin (dB)	Remark
1	2483.500	29.65	11.61	41.26	54.00	-12.74	AVG
2	2500.000	29.56	11.51	41.07	54.00	-12.93	AVG

Project No.:	ZJ00032008	Polarziation:	Horizontal
Standard:	(RE)FCC PART 15 class B 3m_PEAK	Power Source:	
Test item:	Radiation Test	Date:	2013-9-25
Temp./Hum.(%RH):	20/54%RH	Time:	12:03:20
EUT:	JBL AUTHENTICS L16	Distance:	3m
Model:	B-2462	Test Result:	Pass
Note:			

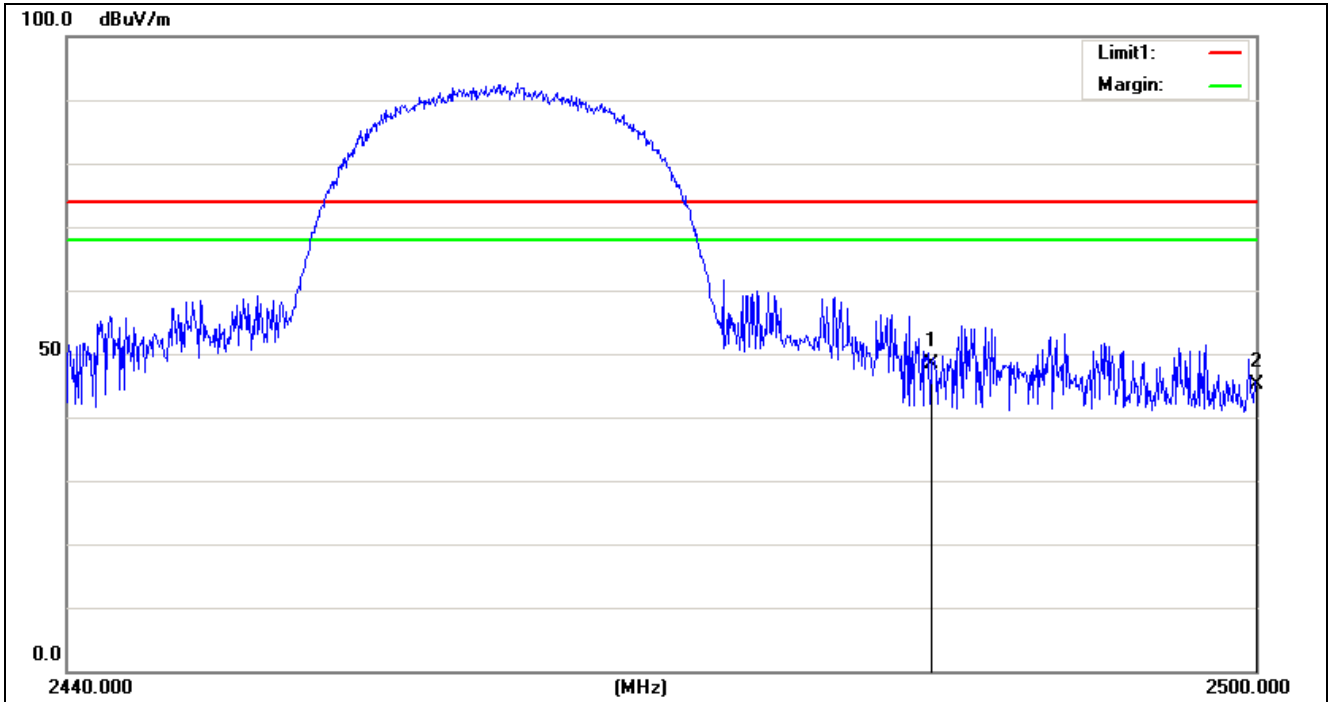

No.	Frequency (MHz)	Reading (dBuV/m)	Correct Factor(dB/m)	Result (dBuV/m)	Limit (dBuV/m)	Margin (dB)	Remark
1	2483.500	36.69	11.61	48.30	74.00	-25.70	peak
2	2500.000	33.55	11.51	45.06	74.00	-28.94	peak

Project No.:	ZJ00032008	Polarziation:	Horizontal
Standard:	(RE)FCC PART 15 class B 3m_AVG	Power Source:	
Test item:	Radiation Test	Date:	2013-9-25
Temp./Hum.(%RH):	20/54%RH	Time:	12:06:49
EUT:	JBL AUTHENTICS L16	Distance:	3m
Model:	B-2462	Test Result:	Pass
Note:			

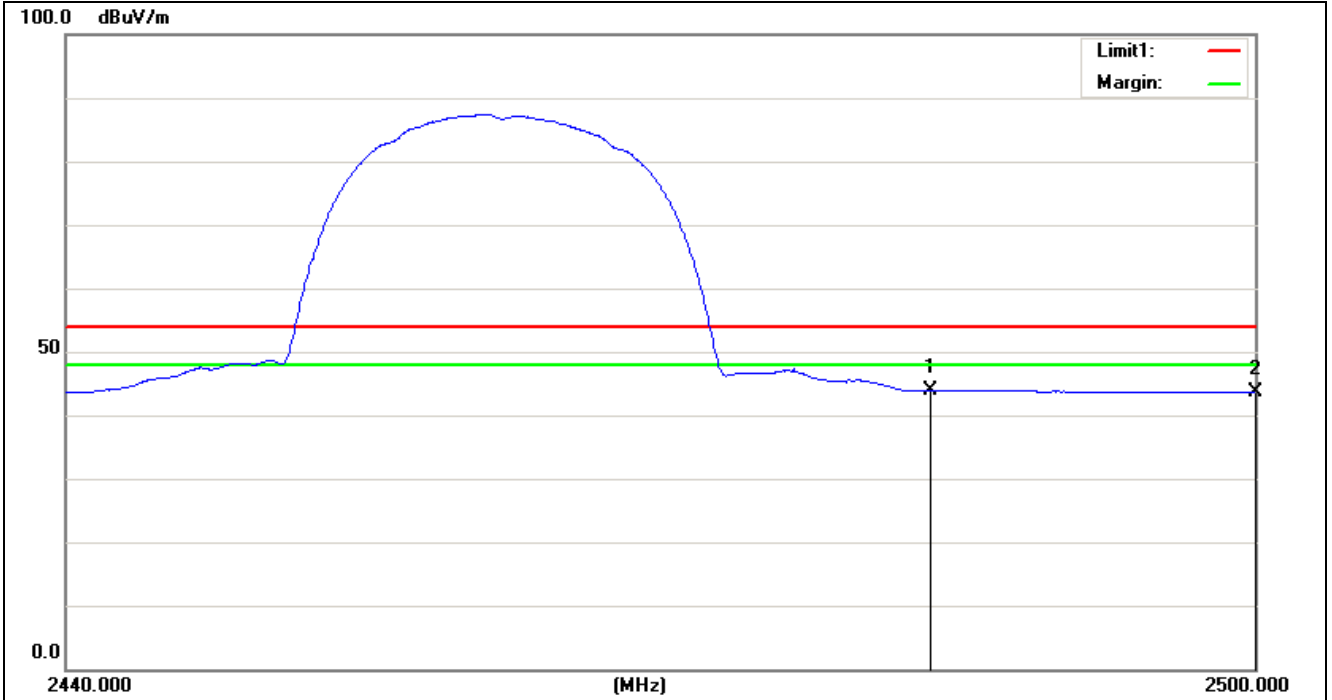

No.	Frequency (MHz)	Reading (dBuV/m)	Correct Factor(dB/m)	Result (dBuV/m)	Limit (dBuV/m)	Margin (dB)	Remark
1	2483.500	32.15	11.61	43.76	54.00	-10.24	AVG
2	2500.000	32.06	11.51	43.57	54.00	-10.43	AVG

Project No.:	ZJ00032008	Polarziation:	Vertical
Standard:	(RE)FCC PART 15 class B 3m_PEAK	Power Source:	
Test item:	Radiation Test	Date:	2013-9-25
Temp./Hum.(%RH):	20/54%RH	Time:	12:14:01
EUT:	JBL AUTHENTICS L16	Distance:	3m
Model:	G-2412	Test Result:	Pass
Note:			

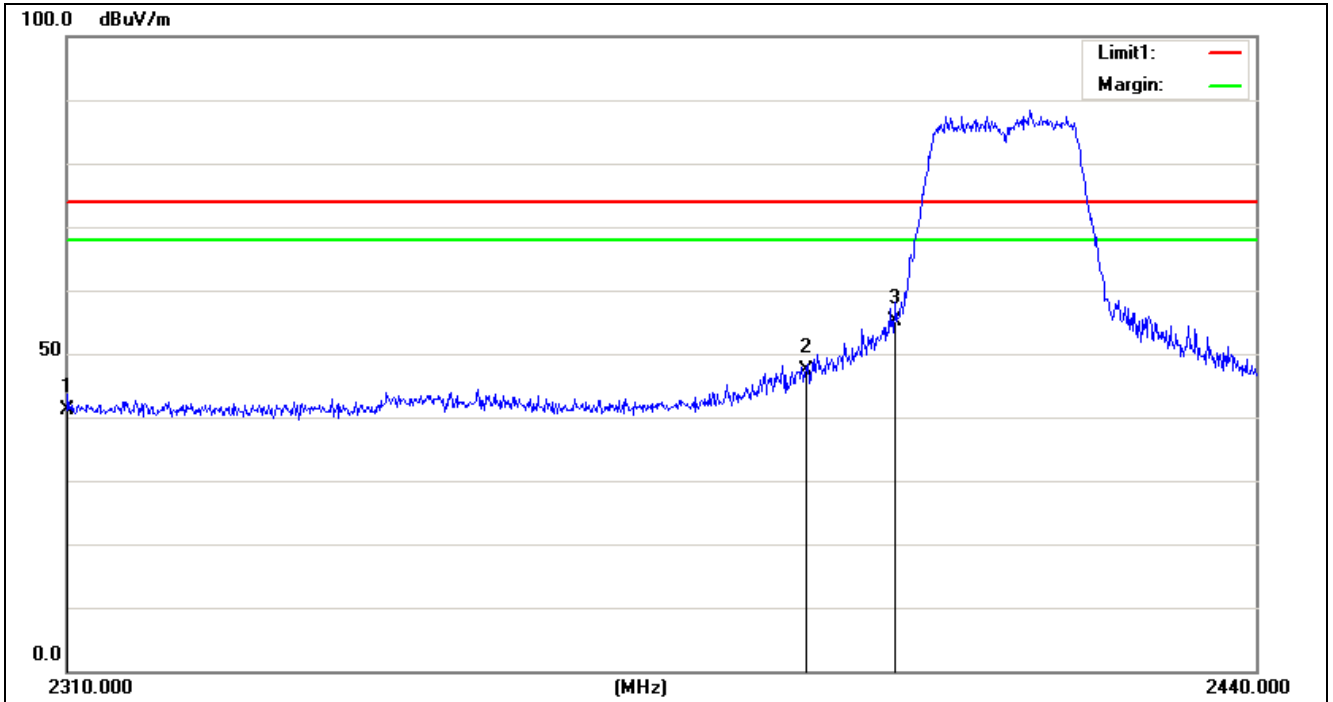

No.	Frequency (MHz)	Reading (dBuV/m)	Correct Factor(dB/m)	Result (dBuV/m)	Limit (dBuV/m)	Margin (dB)	Remark
1	2310.000	30.56	10.63	41.19	74.00	-32.81	peak
2	2390.000	35.63	11.64	47.27	74.00	-26.73	peak
3	2400.000	43.34	11.90	55.24	74.00	-18.76	peak

Project No.:	ZJ00032008	Polarziation:	Vertical
Standard:	(RE)FCC PART 15 class B 3m_AVG	Power Source:	
Test item:	Radiation Test	Date:	2013-9-25
Temp./Hum.(%RH):	20/54%RH	Time:	12:11:45
EUT:	JBL AUTHENTICS L16	Distance:	3m
Model:	G-2412	Test Result:	Pass
Note:			

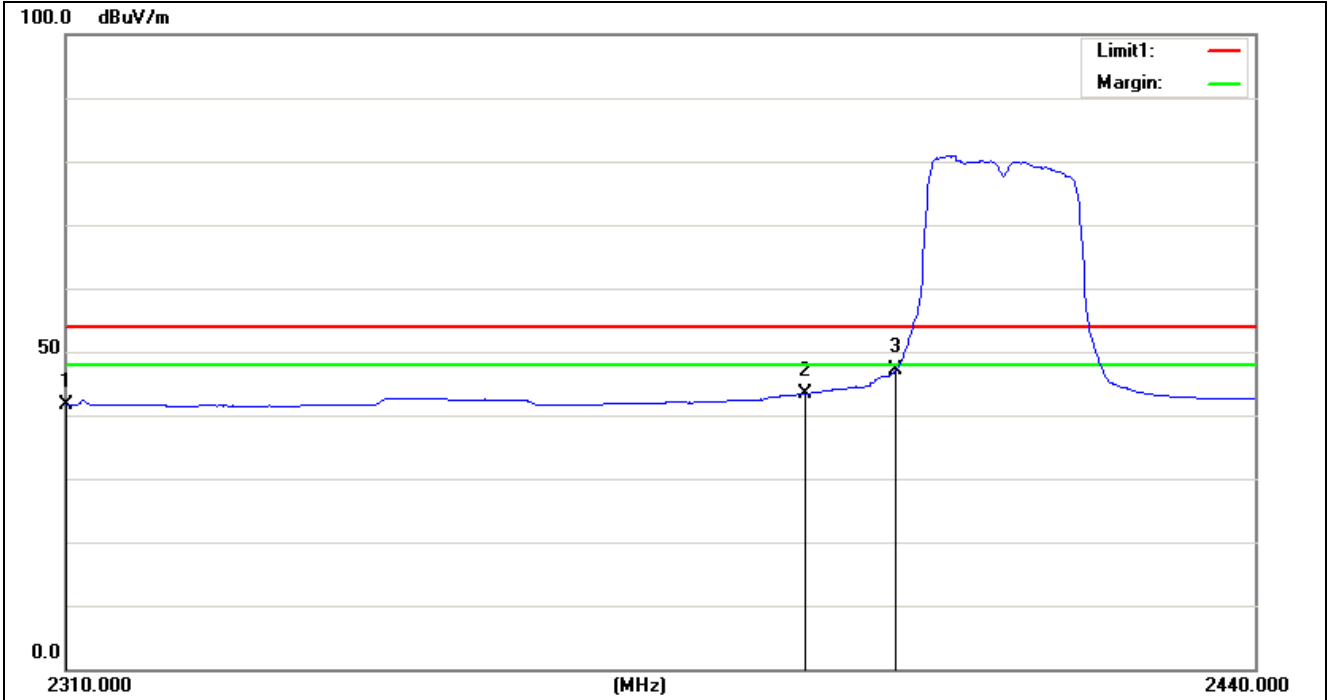

No.	Frequency (MHz)	Reading (dBuV/m)	Correct Factor(dB/m)	Result (dBuV/m)	Limit (dBuV/m)	Margin (dB)	Remark
1	2310.000	31.05	10.63	41.68	54.00	-12.32	AVG
2	2390.000	31.81	11.64	43.45	54.00	-10.55	AVG
3	2400.000	35.20	11.90	47.10	54.00	-6.90	AVG

Project No.:	ZJ00032008	Polarziation:	Horizontal
Standard:	(RE)FCC PART 15 class B 3m_PEAK	Power Source:	
Test item:	Radiation Test	Date:	2013-9-25
Temp./Hum.(%RH):	20/54%RH	Time:	12:12:54
EUT:	JBL AUTHENTICS L16	Distance:	3m
Model:	G-2412	Test Result:	Pass
Note:			

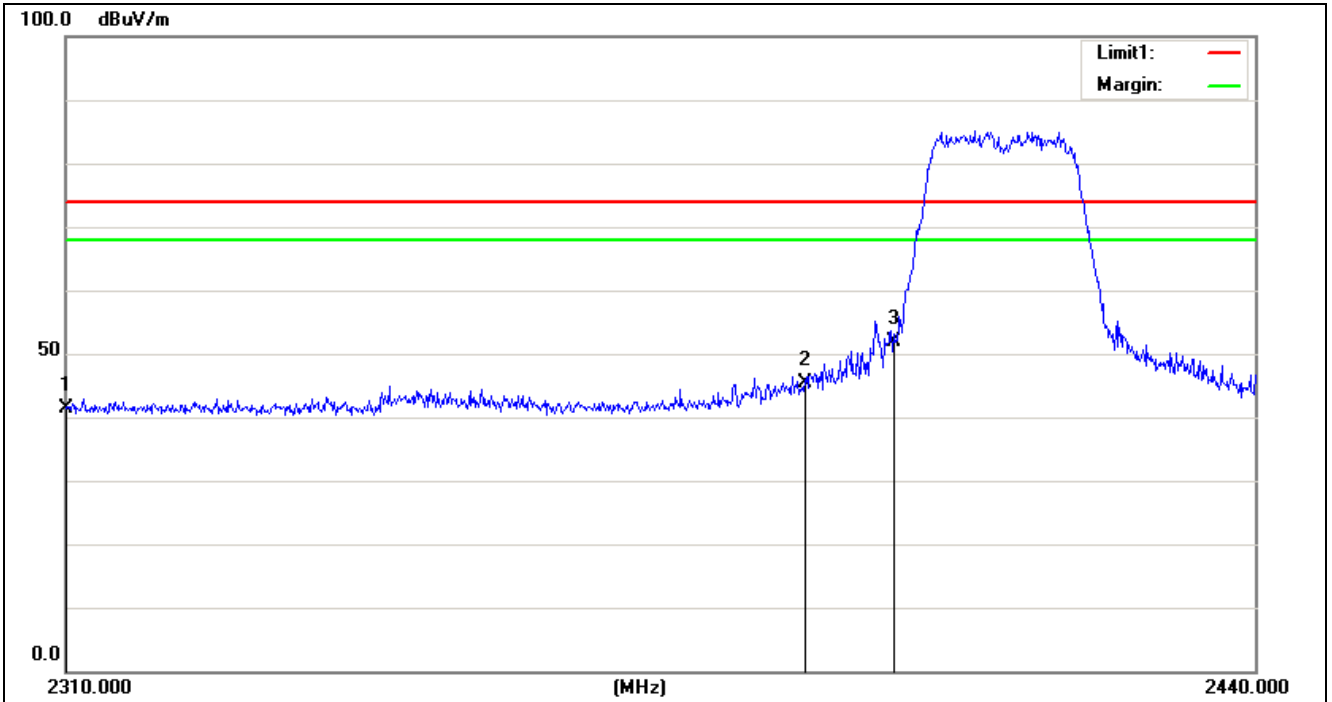

No.	Frequency (MHz)	Reading (dBuV/m)	Correct Factor(dB/m)	Result (dBuV/m)	Limit (dBuV/m)	Margin (dB)	Remark
1	2310.000	30.63	10.63	41.26	74.00	-32.74	peak
2	2390.000	33.73	11.64	45.37	74.00	-28.63	peak
3	2400.000	40.07	11.90	51.97	74.00	-22.03	peak

Project No.:	ZJ00032008	Polarziation:	Horizontal
Standard:	(RE)FCC PART 15 class B 3m_AVG	Power Source:	
Test item:	Radiation Test	Date:	2013-9-25
Temp./Hum.(%RH):	20/54%RH	Time:	12:10:45
EUT:	JBL AUTHENTICS L16	Distance:	3m
Model:	G-2412	Test Result:	Pass
Note:			

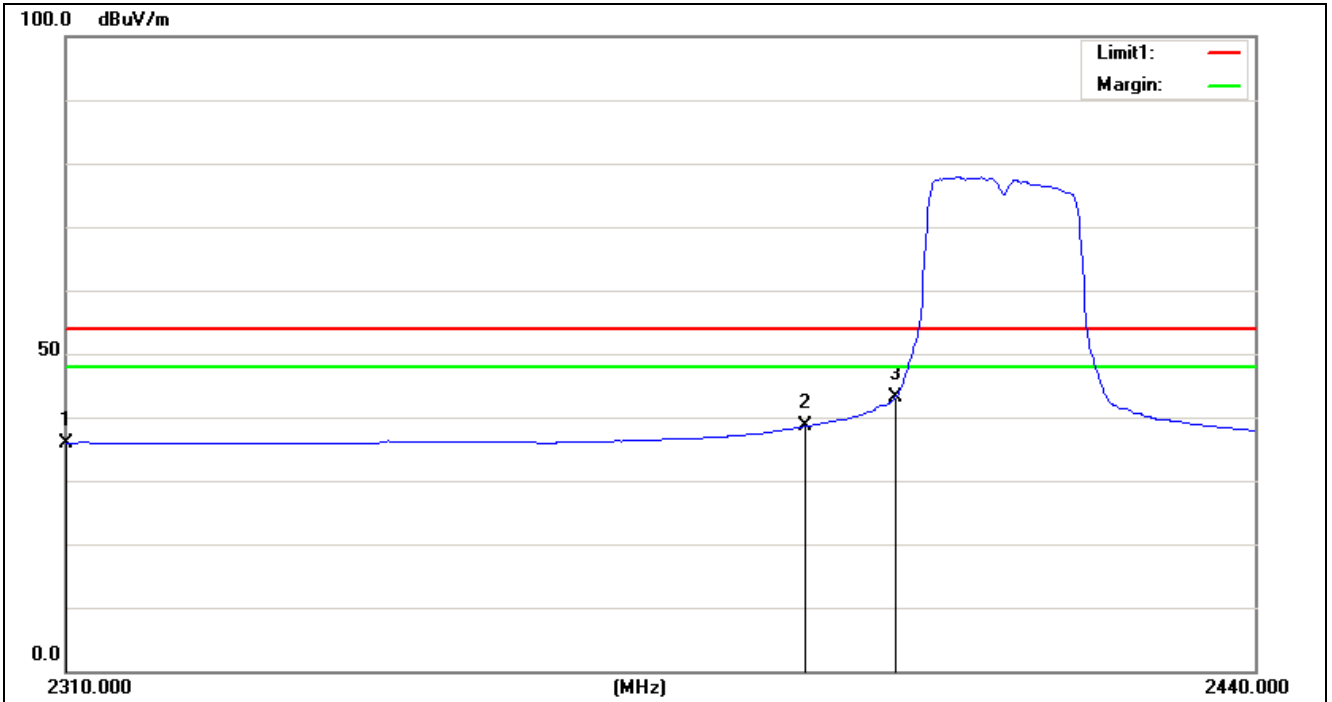

No.	Frequency (MHz)	Reading (dBuV/m)	Correct Factor(dB/m)	Result (dBuV/m)	Limit (dBuV/m)	Margin (dB)	Remark
1	2310.000	25.32	10.63	35.95	54.00	-18.05	AVG
2	2390.000	26.94	11.64	38.58	54.00	-15.42	AVG
3	2400.000	31.35	11.90	43.25	54.00	-10.75	AVG

Project No.:	ZJ00032008	Polarziation:	Vertical
Standard:	(RE)FCC PART 15 class B 3m_PEAK	Power Source:	
Test item:	Radiation Test	Date:	2013-9-25
Temp./Hum.(%RH):	20/54%RH	Time:	12:15:48
EUT:	JBL AUTHENTICS L16	Distance:	3m
Model:	G-2462	Test Result:	Pass
Note:			

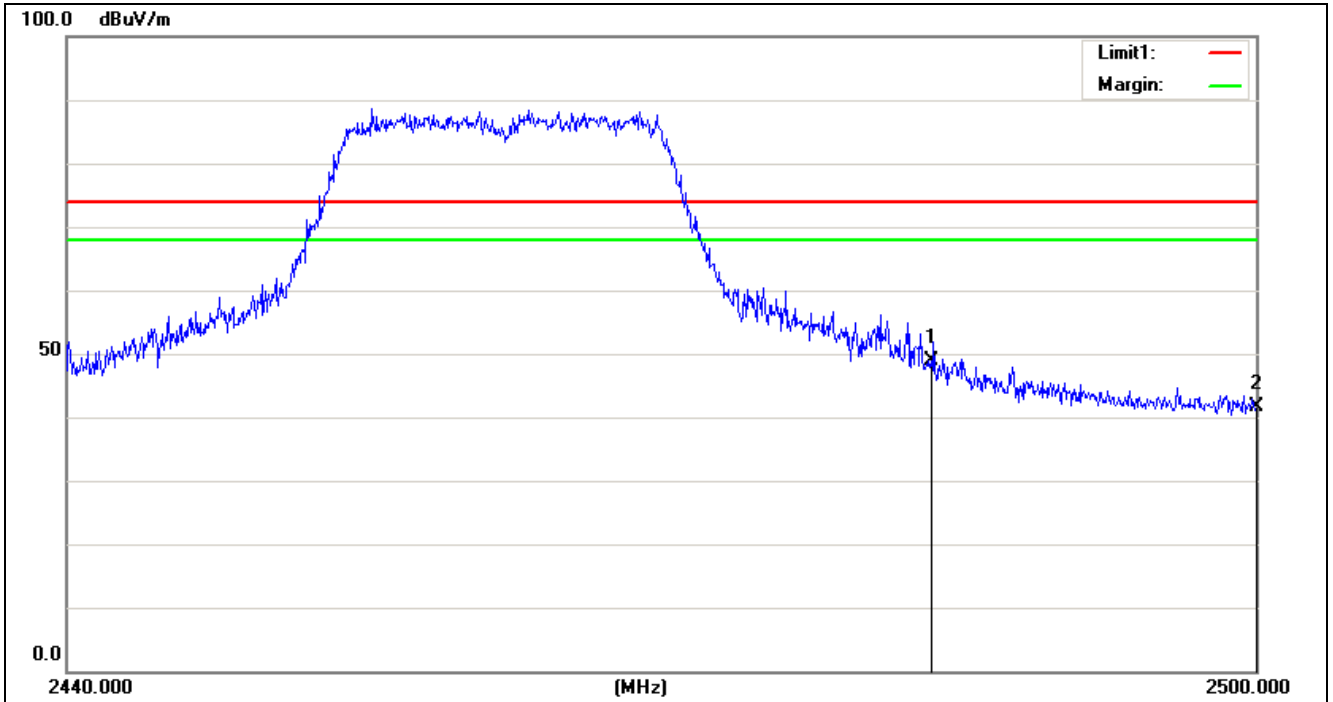

No.	Frequency (MHz)	Reading (dBuV/m)	Correct Factor(dB/m)	Result (dBuV/m)	Limit (dBuV/m)	Margin (dB)	Remark
1	2483.500	37.20	11.61	48.81	74.00	-25.19	peak
2	2500.000	30.06	11.51	41.57	74.00	-32.43	peak

Project No.:	ZJ00032008	Polarziation:	Vertical
Standard:	(RE)FCC PART 15 class B 3m_AVG	Power Source:	
Test item:	Radiation Test	Date:	2013-9-25
Temp./Hum.(%RH):	20/54%RH	Time:	12:17:43
EUT:	JBL AUTHENTICS L16	Distance:	3m
Model:	G-2462	Test Result:	Pass
Note:			

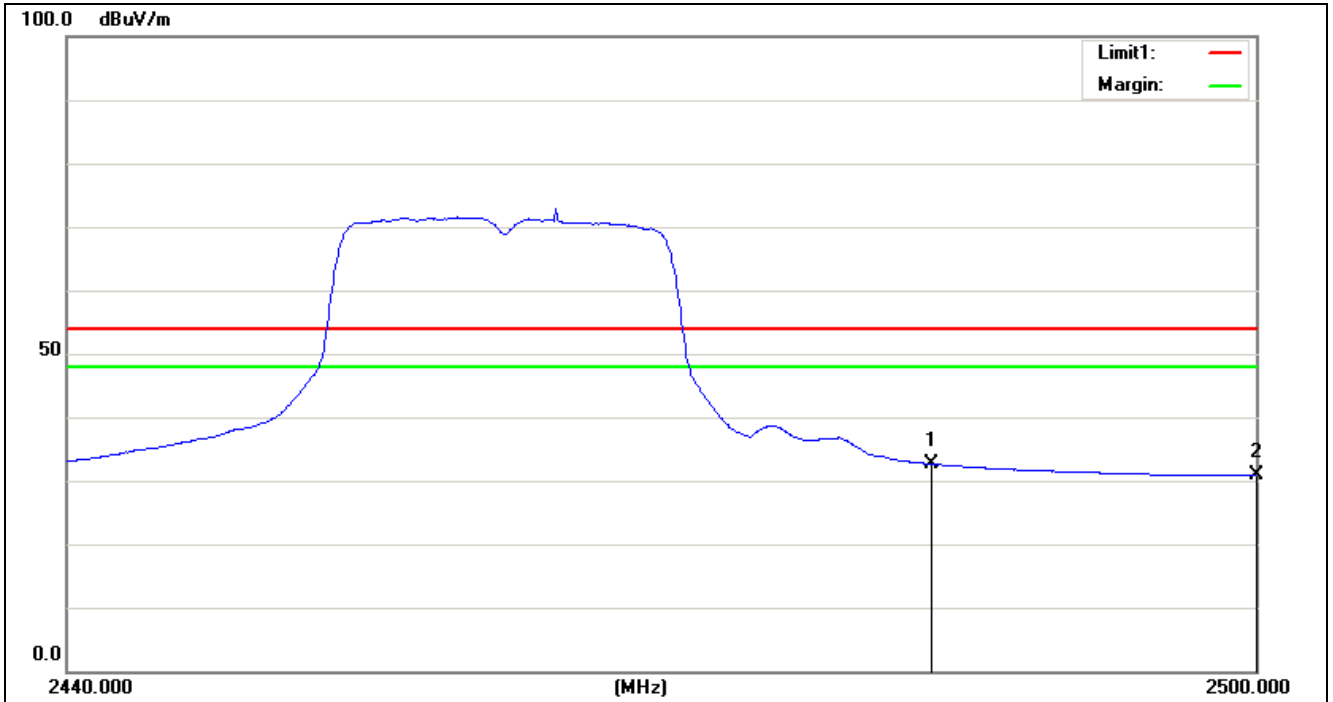

No.	Frequency (MHz)	Reading (dBuV/m)	Correct Factor(dB/m)	Result (dBuV/m)	Limit (dBuV/m)	Margin (dB)	Remark
1	2483.500	21.04	11.61	32.65	54.00	-21.35	AVG
2	2500.000	21.33	11.51	32.39	54.00	-21.61	AVG

Project No.:	ZJ00032008	Polarziation:	Horizontal
Standard:	(RE)FCC PART 15 class B 3m_PEAK	Power Source:	
Test item:	Radiation Test	Date:	2013-9-25
Temp./Hum.(%RH):	20/54%RH	Time:	12:16:31
EUT:	JBL AUTHENTICS L16	Distance:	3m
Model:	G-2462	Test Result:	Pass
Note:			

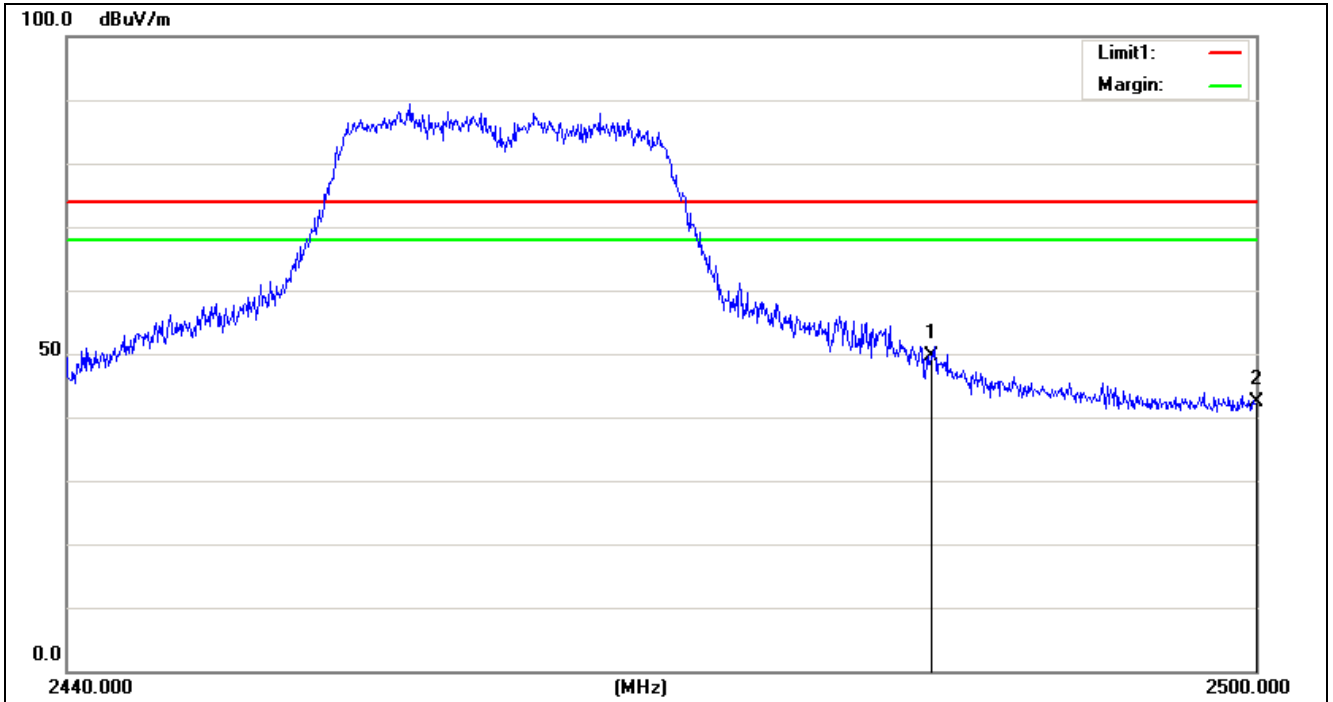

No.	Frequency (MHz)	Reading (dBuV/m)	Correct Factor(dB/m)	Result (dBuV/m)	Limit (dBuV/m)	Margin (dB)	Remark
1	2483.500	38.07	11.61	49.68	74.00	-24.32	peak
2	2500.000	30.95	11.51	42.46	74.00	-31.54	peak

Project No.:	ZJ00032008	Polarziation:	Horizontal
Standard:	(RE)FCC PART 15 class B 3m_AVG	Power Source:	
Test item:	Radiation Test	Date:	2013-9-25
Temp./Hum.(%RH):	20/54%RH	Time:	12:18:25
EUT:	JBL AUTHENTICS L16	Distance:	3m
Model:	G-2462	Test Result:	Pass
Note:			

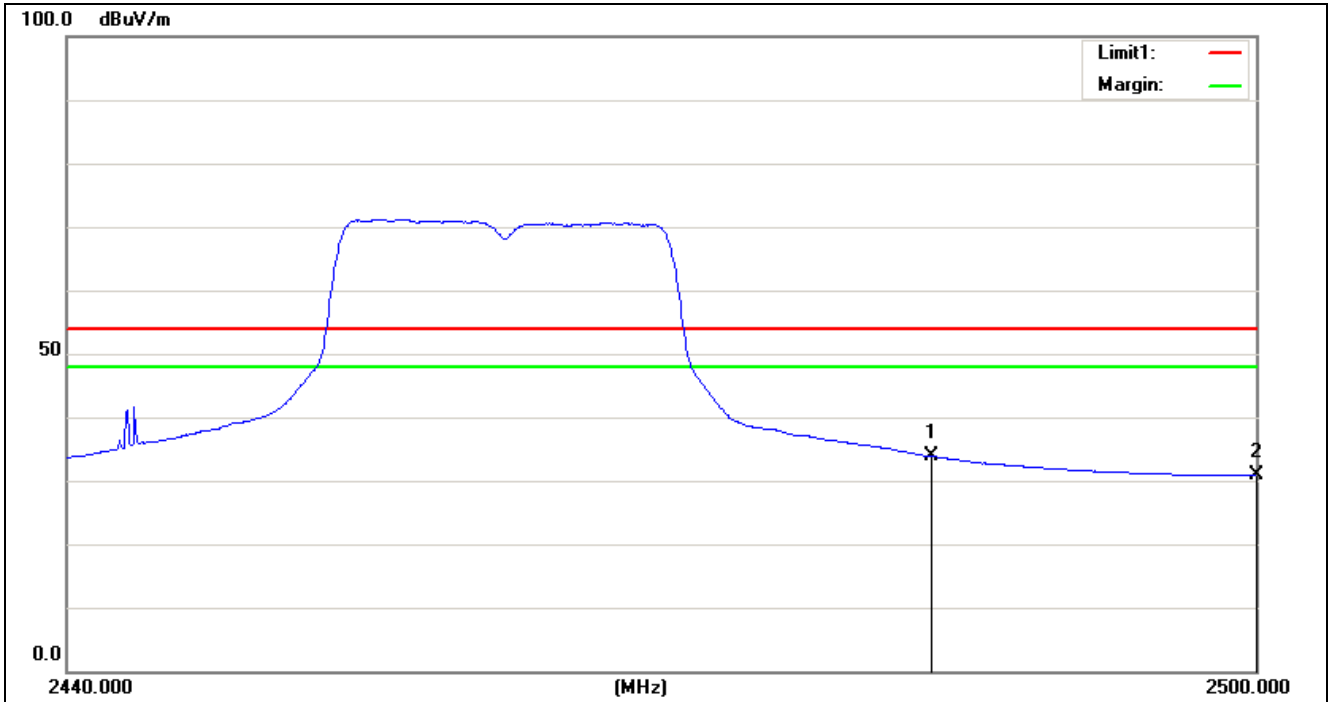

No.	Frequency (MHz)	Reading (dBuV/m)	Correct Factor(dB/m)	Result (dBuV/m)	Limit (dBuV/m)	Margin (dB)	Remark
1	2483.500	23.27	11.61	34.88	54.00	-19.12	AVG
2	2500.000	21.42	11.51	32.93	54.00	-21.07	AVG

Note: factor =Cable loss+ Space loss-Antenna factor-Amplifier

12. BAND-EDGE MEASUREMENTS

12.1 LIMITS

FCC 15.247(d) & 15.209

12.2 TEST PROCEDURES

Test procedures follow KDB 558074 D01 DTS Measurement Guidance v03r01.

Remove the antenna from the EUT and then connect a low attenuation cable from the antenna port to the spectrum.

1. Reference level measurement

Below 1GHz Set the spectrum analyzer: RBW =100KHz VBW \geq 3*RBW, Set the span to \geq 1.5 times the DTS bandwidth. Sweep = auto; Detector Function = peak. Trace = Max-hold. Allow the trace to stabilize.

2. Set the spectrum analyzer: RBW =100KHz VBW \geq 3*RBW, Set the span to \geq 1.5 times the DTS bandwidth. Sweep = auto; Detector Function = peak. Trace = Max-hold. Allow the trace to stabilize.

12.3 TEST SETUP

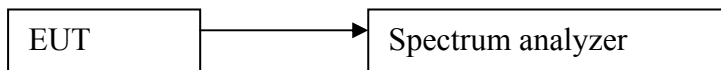

12.4 TEST RESULTS

802.11b mode:
Channel 2412MHz
reference level:

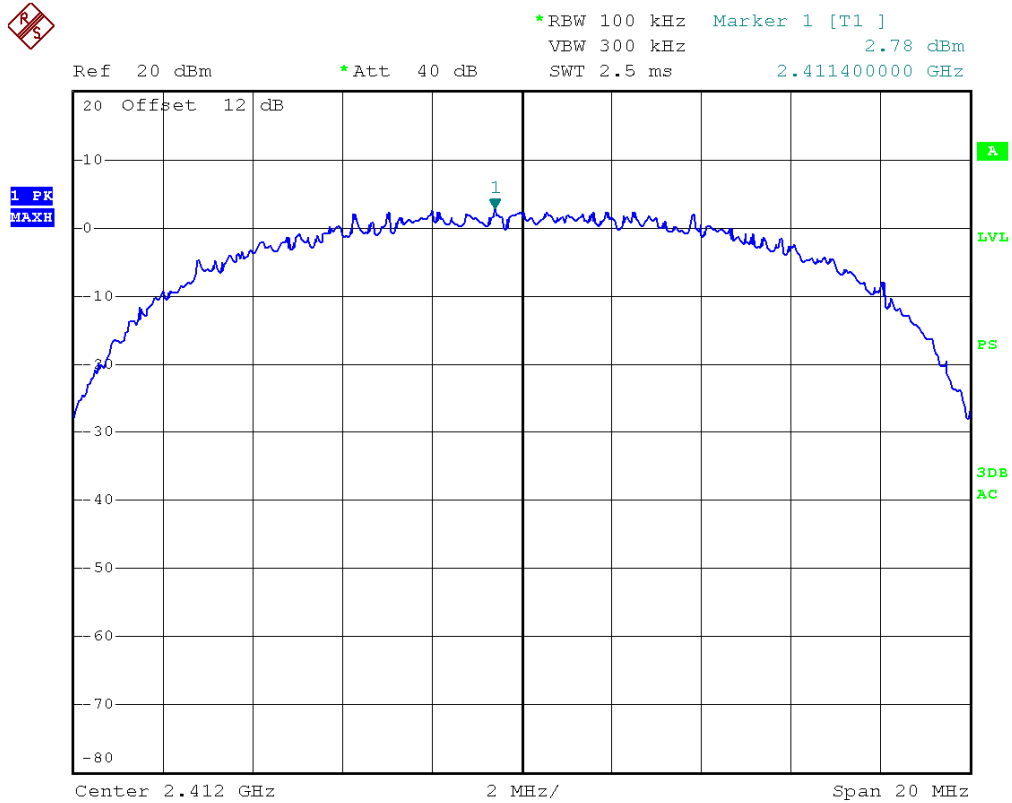

Band edge:

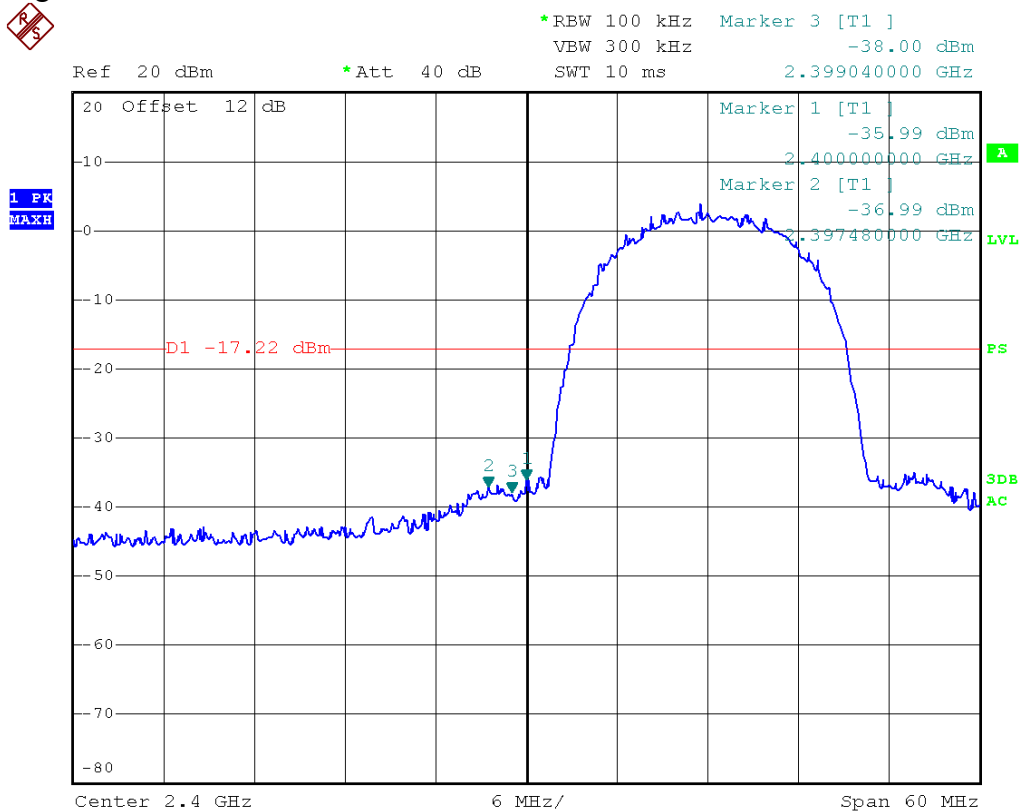

802.11g mode:
Channel 2412MHz
reference level:

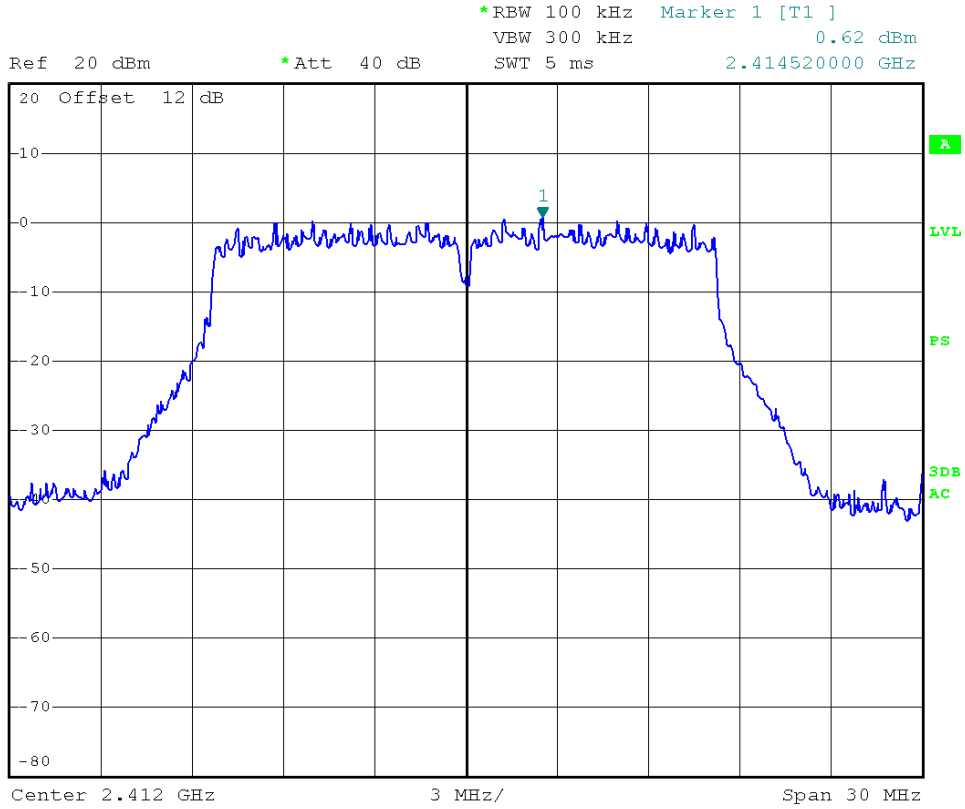

Band edge:

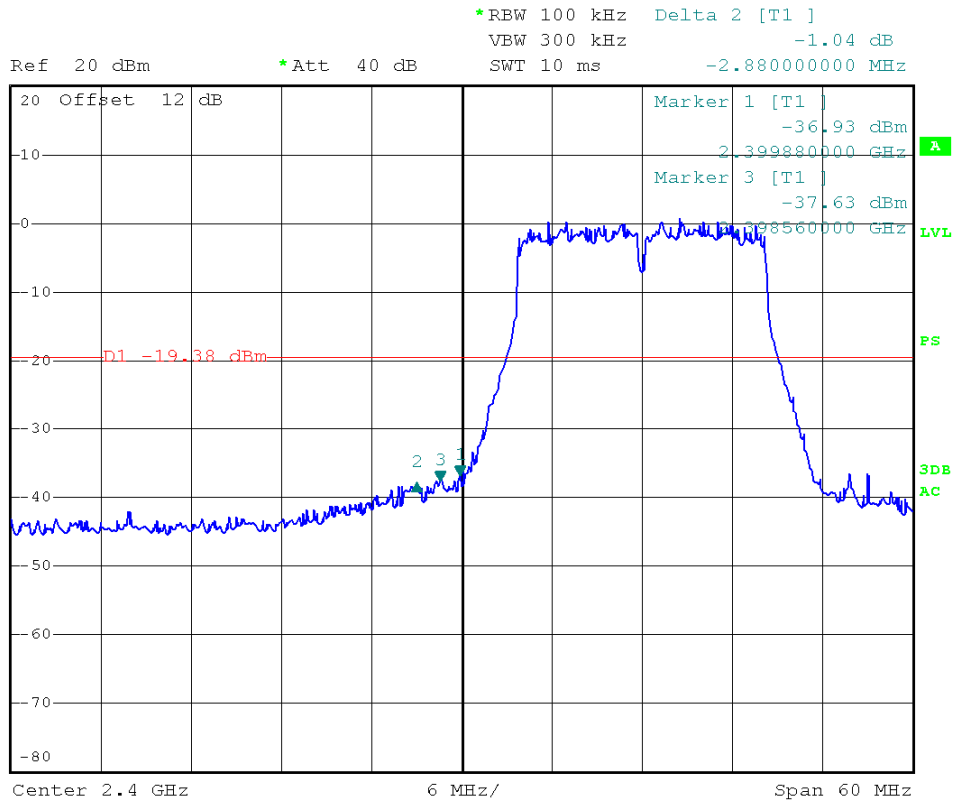

802.11g mode:
Channel 2462MHz
reference level:

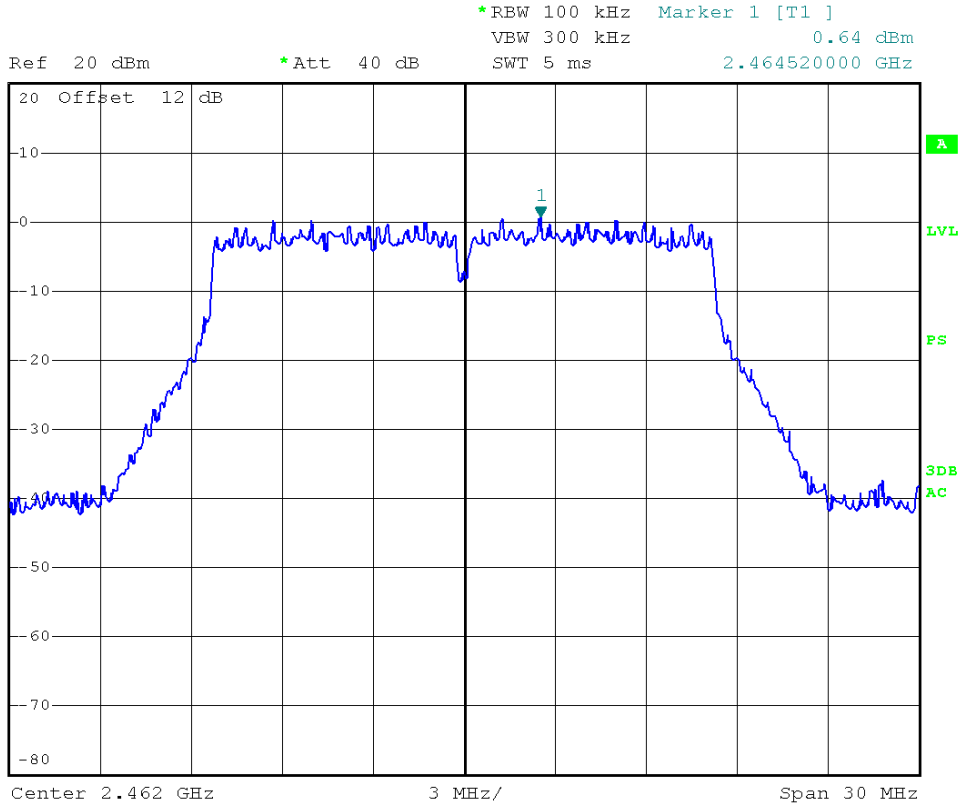

Band edge:

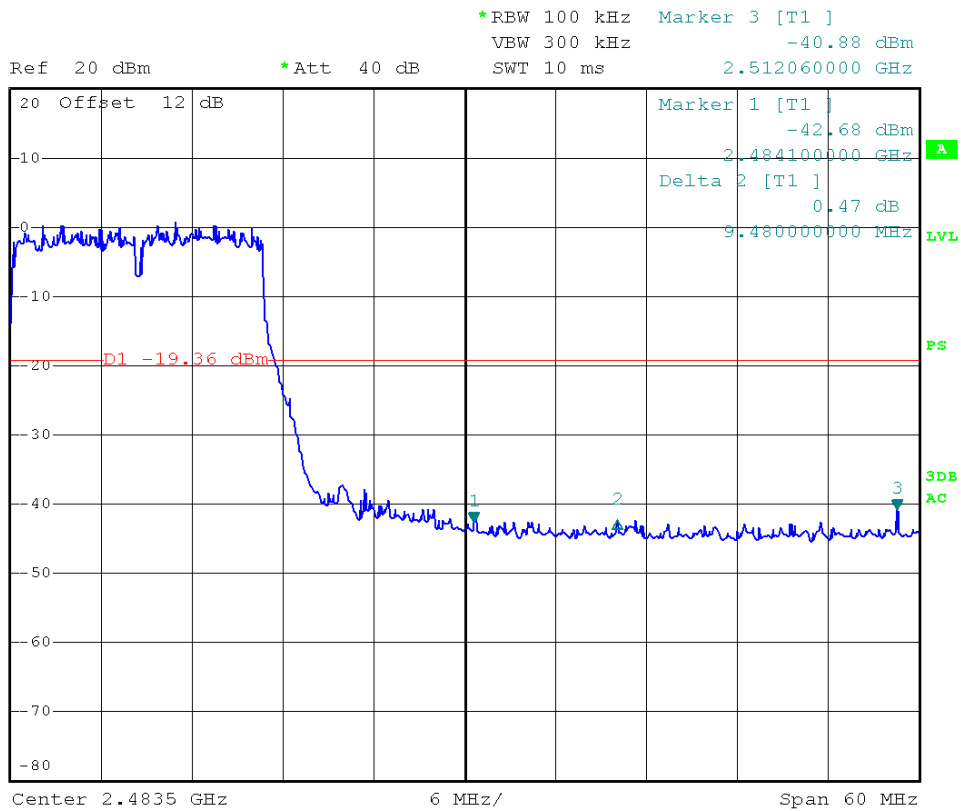

-----This is the last page of the report.-----