



Valued Quality. Delivered.

TEST REPORT

Report Number: 16081553HKG-001

Application
for
Original Grant of 47 CFR Part 15 Certification
RSS-247 Issue 1 Equipment Certification

24 Channel Digital Mixer/Recorder

FCC ID: API-UI24RMIXER

IC: 6132A-UI24RMIXER

This report contains the data of 2.4GHz WLAN (WiFi) portion only.

Prepared and Checked by:

Approved by:

Signed On File

Wong Cheuk Ho, Herbert
Lead Engineer

Koo Wai Ip
Technical Supervisor
February 08, 2017

- Intertek's standard Terms and Conditions can be obtained at our website: <http://www.intertek.com/terms/>.
- The test report only allows to be revised within the retention period unless further standard or the requirement was noticed.
- This report is for the exclusive use of Intertek's Client and is provided pursuant to the agreement between Intertek and its Client. Intertek's responsibility and liability are limited to the terms and conditions of the agreement. Intertek assumes no liability to any party, other than to the Client in accordance with the agreement, for any loss, expense or damage occasioned by the use of this report. Only the Client is authorized to permit copying or distribution of this report and then only in its entirety. Any use of the Intertek name or one of its marks for the sale or advertisement of the tested material, product or service must first be approved in writing by Intertek. The observations and test results in this report are relevant only to the sample tested. This report by itself does not imply that the material, product, or service is or has ever been under an Intertek certification program.
- © 2016 Intertek

Intertek Testing Services Hong Kong Ltd.

2/F., Garment Centre, 576 Castle Peak Road, Kowloon, Hong Kong.
Tel: (852) 2173 8888 Fax: (852) 2785 5487 Website: www.hk.intertek-etlsemko.com

INTERTEK TESTING SERVICES

GENERAL INFORMATION

Applicant Name:	Harman International Industries, Inc
Applicant Address:	8500 Balboa Boulevard, Northridge, California, 91329, United States.
Contact Person:	Tim Song
Tel:	(818) 898 8173
Fax:	(818) 892 0325
Manufacturer:	Harman International Industries, Inc
Manufacturer Address:	8500 Balboa Boulevard, Northridge, California, 91329, United States.
FCC Specification Standard:	FCC Part 15, 2015 Edition
IC Specification Standard:	RSS-247 Issue 1, May 2015 RSS-Gen Issue 4, November 2014
FCC ID:	API-UI24RMIXER
IC:	6132A-UI24RMIXER
Brand Name:	Soundcraft
FCC Model(s):	Ui24R
For IC HVIN:	Ui24R
For IC PMN:	Ui24R
Type of EUT:	Digital Transmission System Transmitter
Description of EUT:	24 Channel Digital Mixer/Recorder
Serial Number:	N/A
Sample Receipt Date:	November 01, 2016
Date of Test:	November 01, 2016 to February 08, 2017
Report Date:	February 08, 2017
Environmental Conditions:	Temperature: +10 to 40°C Humidity: 10 to 90%

INTERTEK TESTING SERVICES

Table of Contents

1.0 Test Results Summary & Statement of Compliance	5
1.1 Summary of Test Results	5
1.2 Statement of Compliance.....	5
2.0 General Description	7
2.1 Product Description	7
2.2 Test Methodology	8
2.3 Test Facility	8
2.4 Related Submittal(s) Grants.....	8
3.0 System Test Configuration	10
3.1 Justification.....	10
3.2 EUT Exercising Software	12
3.3 Details of EUT and Description of Accessories	12
3.4 Measurement Uncertainty.....	12
4.0 Test Results	14
4.1 Maximum Conducted (peak) Output Power at Antenna Terminals	14
4.2 Minimum 6dB RF Bandwidth	16
4.3 Maximum Power Spectral Density	21
4.4 Out of Band Conducted Emissions	26
4.5 Field Strength Calculation	35
4.6 Transmitter Radiated Emissions in Restricted Bands and Spurious Emissions	36
4.6.1 Radiated Emission Configuration Photograph.....	36
4.6.2 Radiated Emission Data	36
4.6.3 Transmitter Duty Cycle Calculation	45
4.7 AC Power Line Conducted Emission	45
4.7.1 AC Power Line Conducted Emission Configuration Photograph	45
4.7.2 AC Power Line Conducted Emission Data.....	45
5.0 Equipment List	49

INTERTEK TESTING SERVICES

**EXHIBIT 1
TEST RESULTS SUMMARY & STATEMENT OF COMPLIANCE**

INTERTEK TESTING SERVICES

1.0 Test Results Summary & Statement of Compliance

1.1 Summary of Test Results

Test Items	FCC Part 15 Section	RSS-247/ RSS-Gen# Section	Results	Details see section
Antenna Requirement	15.203	8.3#	Pass	2.1
Max. Conducted Output Power	15.247(b)(3)&(4)	5.4(4)	Pass	4.1
Min. 6dB RF Bandwidth	15.247(a)(2)	5.2(1)	Pass	4.2
Max. Power Density	15.247(e)	5.2(2)	Pass	4.3
Out of Band Antenna Conducted Emission	15.247(d)	5.5	Pass	4.4
Radiated Emission in Restricted Bands and Spurious Emissions	15.247(d), 15.209 & 15.109	8.9#,8.10#	Pass	4.6
AC Power Line Conducted Emission	15.207 & 15.107	8.8#	Pass	4.7

Note: Pursuant to FCC Part 15 Section 15.215(c), the 20dB bandwidth of the emission was contained within the frequency band designated (mentioned as above) which the EUT operated. The effects, if any, from frequency sweeping, frequency hopping, other modulation techniques and frequency stability over expected variations in temperature and supply voltage were considered.

1.2 Statement of Compliance

The equipment under test is found to be complying with the following standard:

FCC Part 15, 2015 Edition
RSS-247 Issue 1, May 2015
RSS-Gen Issue 4, November 2014

INTERTEK TESTING SERVICES

**EXHIBIT 2
GENERAL DESCRIPTION**

INTERTEK TESTING SERVICES

2.0 General Description

2.1 Product Description

The Equipment Under Test (EUT) is a 24-Channel Digital Mixer/Recorder, equipped with multi-channel XLR/line input/output, headphone output, WiFi, LAN and USB Interface. Its operation can be controlled by a Smartphone/Notebook over WiFi link. The WiFi module covers both 2.4GHz and 5GHz band. For the 2.4GHz band, the EUT has only 802.11b mode that occupies a frequency range from 2412MHz to 2462MHz (11 channels with channel spacing of 5MHz). For 5GHz band, the EUT has only 802.11a mode that occupies a frequency range from 5180MHz to 5240MHz (4 channels with channel spacing of 20MHz) and another frequency range from 5745MHz to 5825MHz (5 channels with channel spacing of 20MHz). The EUT is powered by 100-240VAC. HDMI function is not implemented for this product. The applicant declared that the EUT is a non-MIMO master unit without DFS function. The 2.4GHz and 5GHz portion of WiFi will not transmit simultaneously.

The EUT has two antennas.

The antenna(s) used in the EUT are external, detachable, with reverse-SMA connector.

The circuit description is saved with filename: descri.pdf.

This report covers 2.4GHz band WiFi portion only.

INTERTEK TESTING SERVICES

2.2 Test Methodology

Both AC power line-conducted and radiated emission measurements were performed according to the procedures in ANSI C63.10 (2013). Preliminary radiated scans and all radiated measurements were performed in radiated emission test sites. All Radiated tests were performed at an antenna to EUT distance of 3 meters, unless stated otherwise in the "Justification Section" of this Application. Antenna port conducted measurements were performed according to ANSI C63.10 (2013) and KDB Publication No.558074 D01 v03r05 (08-April-2016). All other measurements were made in accordance with the procedures in 47 CFR Part 2 and RSS-Gen Issue 4 (2014).

2.3 Test Facility

The radiated emission test site, AC conducted emission test site and antenna port conducted measurement facility used to collect the radiated data and conductive data are at Workshop No. 3, G/F., World-Wide Industrial Centre, 43-47 Shan Mei Street, Fo Tan, Sha Tin, N.T., Hong Kong. This test facility and site measurement data have been fully placed on file with the FCC and the Industry Canada.

2.4 Related Submittal(s) Grants

• This is a single application for certification of a transceiver.

This is a single application for certification of a transceiver.

The Declaration of the Conformity procedure of PC Connectivity for this transceiver (with FCC ID: API-UI24RMIXER) is being processed at the same time of this application

INTERTEK TESTING SERVICES

**EXHIBIT 3
SYSTEM TEST CONFIGURATION**

INTERTEK TESTING SERVICES

3.0 System Test Configuration

3.1 Justification

For radiated emissions testing, the equipment under test (EUT) was setup to transmit / receive continuously to simplify the measurement methodology. Care was taken to ensure proper power supply voltages during testing. During testing, all cables (if any) were manipulated to produce worst case emissions.

The EUT was powered by 120VAC.

For the measurements, the EUT was attached to a plastic stand if necessary and placed on the wooden turntable which is four feet in diameter and approximately 0.8m in height above the ground plane for emission measurement at or below 1GHz and 1.5m in height above the ground plane for emission measurement above 1GHz. If the base unit attached to peripherals, they were connected and operational (as typical as possible).

The signal was maximized through rotation and placement in the three orthogonal axes. The antenna height and polarization were varied during the search for maximum signal level. The antenna height was varied from 1 to 4 meters. Radiated emissions were taken at three meters unless the signal level was too low for measurement at that distance. If necessary, a pre-amplifier was used and/or the test was conducted at a closer distance.

For any intentional radiator powered by AC power line, measurements of the radiated signal level of the fundamental frequency component of the emission was performed with the supply voltage varied between 85% and 115% of the nominal rated supply voltage.

Radiated emission measurement for transmitter were performed from the lowest radio frequency signal generated in the device which is greater than 9 kHz to the tenth harmonic of the highest fundamental frequency or to 40 GHz, whichever is lower.

INTERTEK TESTING SERVICES

Justification – Cont'd

Emission that are directly caused by digital circuits in the transmit path and transmitter portion were measured, and the limit are according to FCC Part 15 Section 15.209/ RSS-247 2.5. Digital circuitries used to control additional functions other than the operation of the transmitter are subject to FCC Part 15 Section 15.109/ RSS-247 Section 5.5 Limits.

Detector function for radiated emissions was in peak mode. Average readings, when required, were taken by measuring the duty cycle of the equipment under test and subtracting the corresponding amount in dB from the measured peak readings. A detailed description for the calculation of the average factor can be found in section 4.2.3.

Determination of pulse desensitization was made according to *Hewlett Packard Application Note 150-2, Spectrum Analysis... Pulsed RF*. The effective period (Teff) was referred to Exhibit 4.6.3. With the resolution bandwidth 1MHz and spectrum analyzer IF bandwidth 3dB, the pulse desensitization factor was 0dB.

The EUT along with its peripherals were placed on a 1.0m(W)x1.5m(L) and 0.8m in height wooden table and the EUT was adjusted to maintain a 0.4 meter space from a vertical reference plane. The EUT power cord connected to one LISN (Line impedance stabilization network), which provided 50ohm coupling impedance for measuring instrument. Meanwhile, the peripheral or support equipment power cords connected to a separate LISN. The ac powers for all LISNs were obtained from the same power source. The LISN housing, measuring instrument case, reference ground plane, and vertical ground plane were bounded together. The excess power cable between the EUT and the LISN was bundled. Power cords of non-EUT equipment (peripherals) were not bundled. AC power cords of peripheral equipments draped over the rear edge of the table, and routed them down onto the floor of the ac power line conducted emission test site to the second LISN.

All connecting cables of EUT and peripherals were manipulated to find the maximum emission.

All setting of data rate for 802.11b of WiFi mode had been considered, and worst case test data are shown on this test report.

INTERTEK TESTING SERVICES

3.2 EUT Exercising Software

The EUT exercise program (if any) used during radiated and conducted testing was designed to exercise the various system components in a manner similar to a typical use.

3.3 Details of EUT and Description of Accessories

Details of EUT:

- 1 The EUT is powered by 120VAC

Description of Accessories:

1. 1X Headphone cable of 1.2m long (with termination)
2. 2X 4GB USB Flash (Play and Record)
3. 16X Audio cable of 2m long (with termination)
4. 2X LAN cable of 2m long (with termination)
5. 2X USB cable of 2m long (with termination)
6. 1X Power cable of 2m long
(Provided by Intertek)

3.4 Measurement Uncertainty

When determining of the test conclusion, the Measurement Uncertainty of test at a level of confidence of 95% has been considered. The values of the Measurement uncertainty for radiated emission test and RF conducted measurement test are $\pm 5.3\text{dB}$ and $\pm 0.99\text{dB}$ respectively. The value of the Measurement uncertainty for conducted emission test is $\pm 4.2\text{dB}$.

Uncertainty and Compliance - Unless the standard specifically states that measured values are to be extended by the measurement uncertainty in determining compliance, all compliance determinations are based on the actual measured value.

INTERTEK TESTING SERVICES

**EXHIBIT 4
TEST RESULTS**

INTERTEK TESTING SERVICES

4.0 Test Results

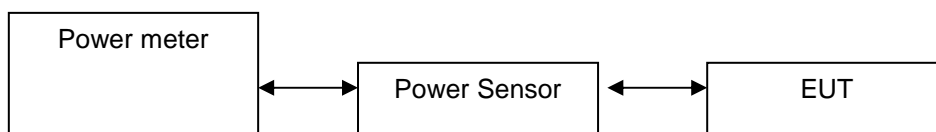

4.1 Maximum Conducted (peak) Output Power at Antenna Terminals

The antenna port of the EUT was connected to the input of a power meter.

- The antenna power of the EUT was connected to the input of a power meter. Power was read directly and cable loss correction was added to the reading to obtain power at the EUT antenna terminals. The measurement procedure 9.1.2 was used.
- The EUT should be configured to transmit continuously (at a minimum duty cycle of 98%) at full power over the measurement duration. The measurement procedure AVG1 was used.

IEEE 802.11b (DSSS, 1 Mbps) Antenna Gain = 2 dBi (Antenna 1)		
Frequency (MHz)	Output in dBm	Output in mWatt
Low Channel: 2412	13.54	22.59
Middle Channel: 2437	13.48	22.28
High Channel: 2462	13.88	24.43

IEEE 802.11b (DSSS, 1 Mbps) Antenna Gain = 2 dBi (Antenna 2)		
Frequency (MHz)	Output in dBm	Output in mWatt
Low Channel: 2412	9.48	8.87
Middle Channel: 2437	9.82	9.59
High Channel: 2462	8.78	7.55

INTERTEK TESTING SERVICES

4.1 Maximum Conducted (peak) Output Power at Antenna Terminals – Cont'd

Cable loss: 0.5 dB External Attenuation: 0 dB

IEEE 802.11b (DSSS, 1 Mbps) (Antenna 1)
max. conducted (peak) output level = 13.88dBm

IEEE 802.11b (DSSS, 1 Mbps) (Antenna 2)
max. conducted (peak) output level = 9.82dBm

Limits:

1W (30dBm) for antennas with gains of 6dBi or less

___W (___dBm) for antennas with gains more than 6dBi

INTERTEK TESTING SERVICES

RF Conduct measurement Test Setup

The figure below shows the test setup, which is utilized to make these measurements.

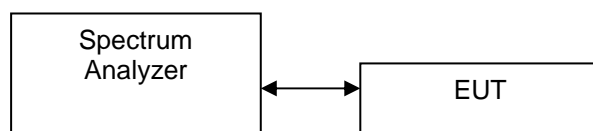

4.2 Minimum 6dB RF Bandwidth

The antenna port of the EUT was connected to the input of a spectrum analyzer. The EBW measurement procedure was used. A PEAK output reading was taken, a DISPLAY line was drawn 6dB lower than PEAK level. The 6dB bandwidth was determined from where the channel output spectrum intersected the display line.

IEEE 802.11b (DSSS, 1 Mbps) (Antenna 1)	
Frequency (MHz)	6dB Bandwidth (MHz)
Low Channel: 2412	10.24
Middle Channel: 2437	10.20
High Channel: 2462	10.24

IEEE 802.11b (DSSS, 1 Mbps) (Antenna 2)	
Frequency (MHz)	6dB Bandwidth (MHz)
Low Channel: 2412	10.24
Middle Channel: 2437	10.20
High Channel: 2462	10.16

Limits:

6 dB bandwidth shall be at least 500kHz

INTERTEK TESTING SERVICES

Plots of 6dB RF bandwidth (Antenna 1)

802.11b, Lowest Channel

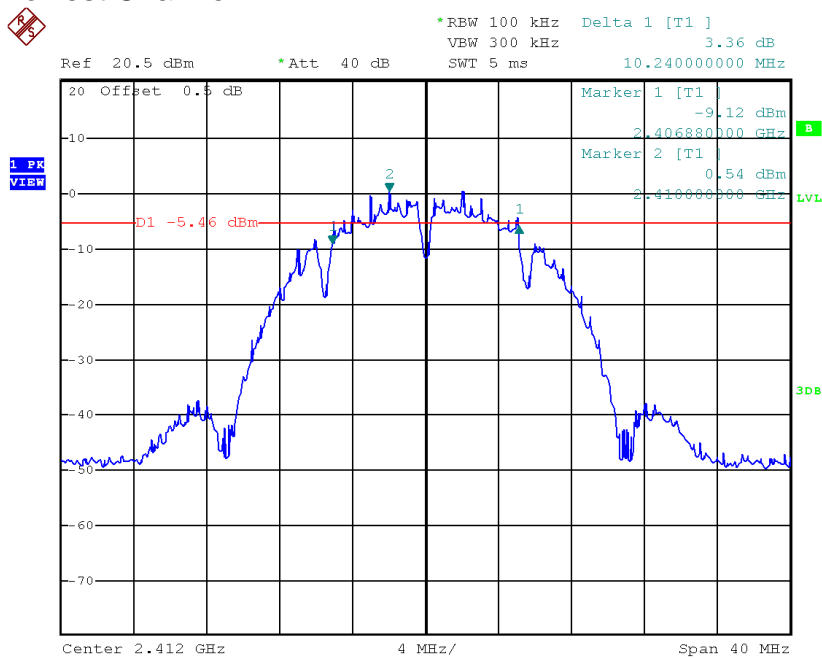

Date: 8.NOV.2016 09:10:45

802.11b, Middle Channel

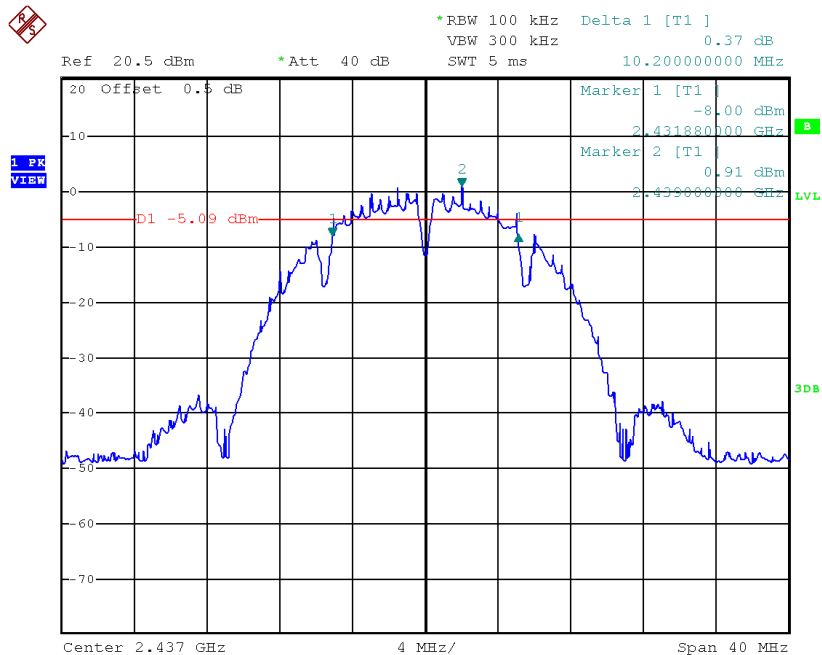

Date: 8.NOV.2016 09:23:49

INTERTEK TESTING SERVICES

Plots of 6dB RF bandwidth (Antenna 1)

802.11b, Highest Channel

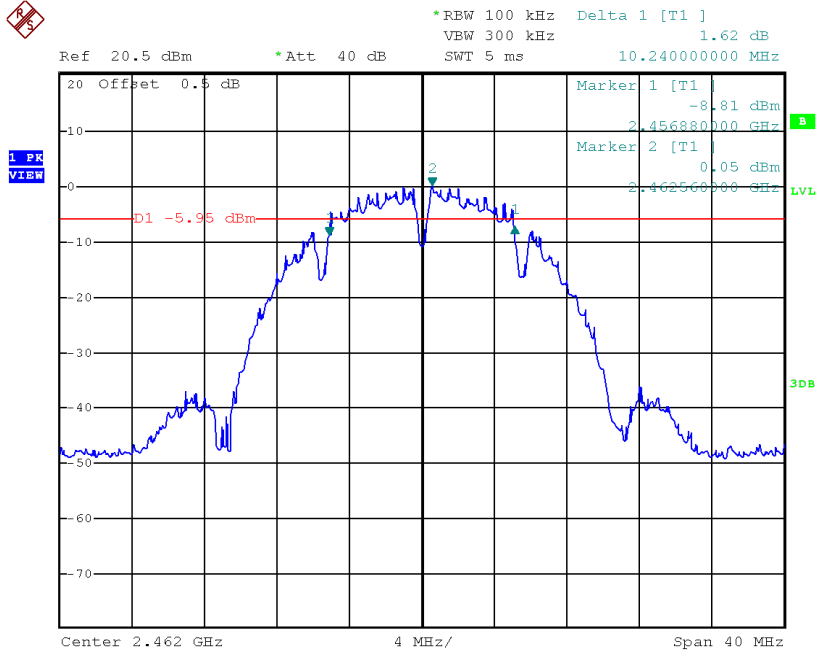

Date: 8.NOV.2016 09:34:36

INTERTEK TESTING SERVICES

Plots of 6dB RF bandwidth (Antenna 2)

802.11b, Lowest Channel

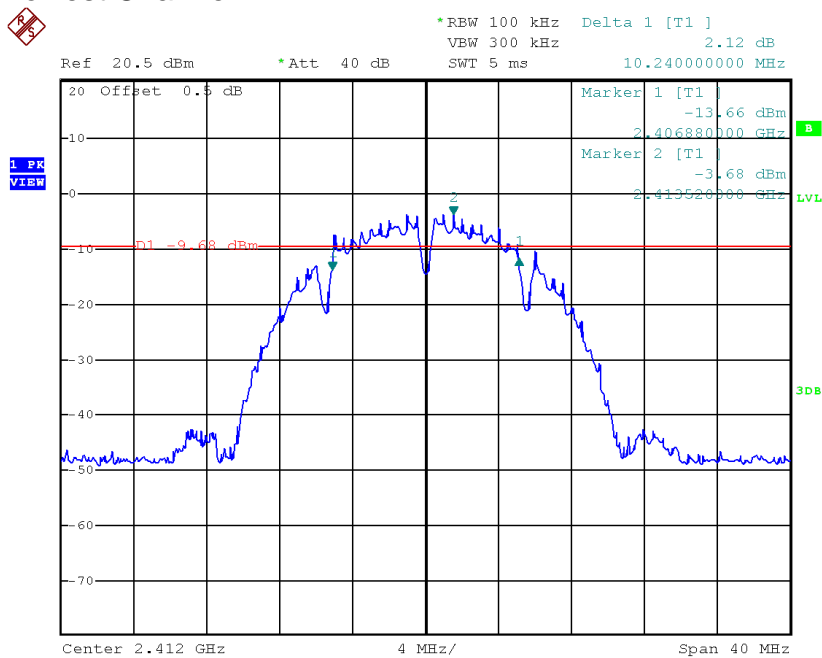

Date: 8.NOV.2016 09:14:42

802.11b, Middle Channel

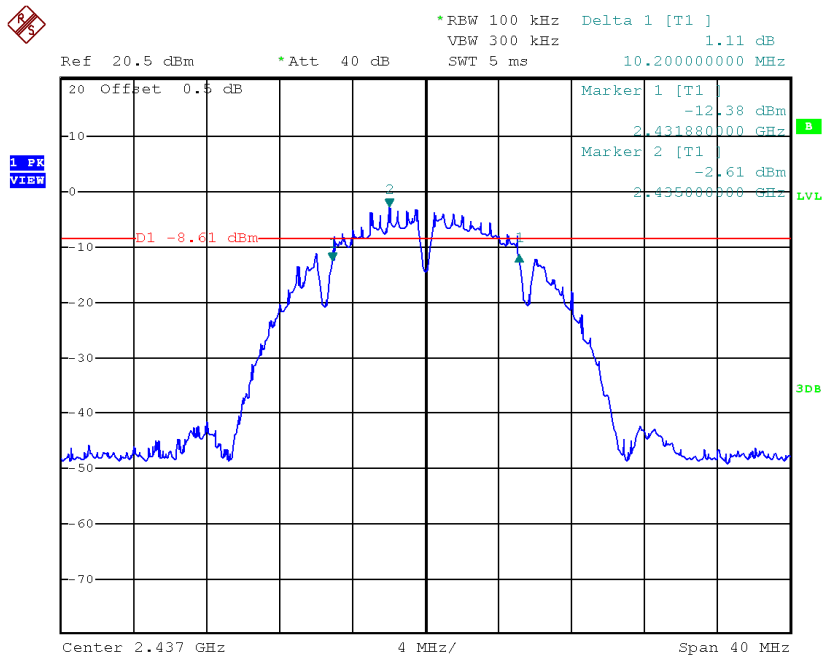

Date: 8.NOV.2016 09:29:41

INTERTEK TESTING SERVICES

Plots of 6dB RF bandwidth (Antenna 2)

802.11b, Highest Channel

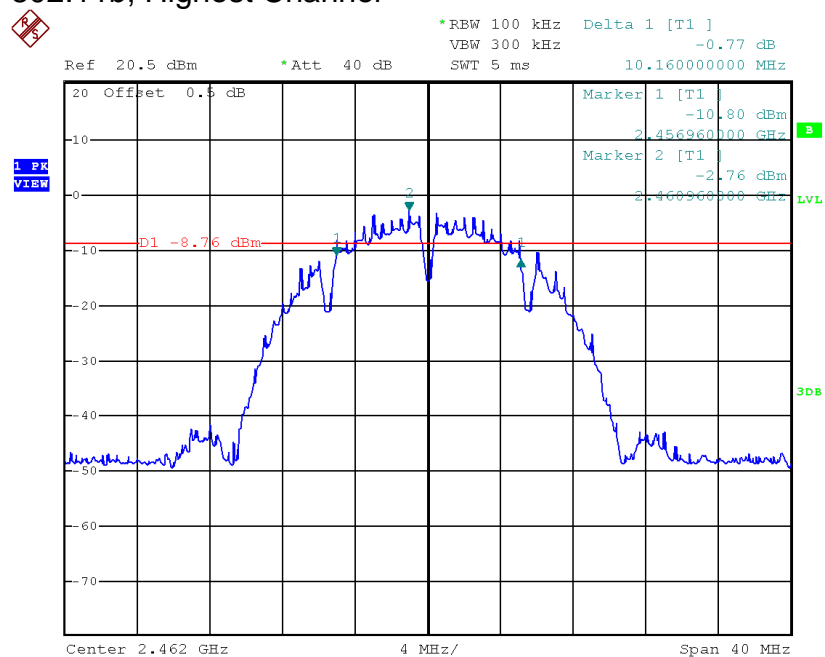

Date: 8.NOV.2016 09:39:01

INTERTEK TESTING SERVICES

4.3 Maximum Power Spectral Density

Antenna output of the EUT was coupled directly to spectrum analyzer. The measurement procedure 10.2 PKPSD-1 was used. If an external attenuator and/or cable was used, these losses are compensated for using the OFFSET function of the analyser.

IEEE 802.11b (DSSS, 1 Mbps) (Antenna 1)	
Frequency (MHz)	PSD in 100kHz (dBm)
Low Channel: 2412	2.11
Middle Channel: 2437	2.13
High Channel: 2462	1.23

IEEE 802.11b (DSSS, 1 Mbps) (Antenna 2)	
Frequency (MHz)	PSD in 100kHz (dBm)
Low Channel: 2412	-1.95
Middle Channel: 2437	-2.33
High Channel: 2462	-2.72

Cable Loss: 0.5 dB

Limit:
8dBm

INTERTEK TESTING SERVICES

Plots of power spectral density (Antenna 1)

802.11b, Lowest channel

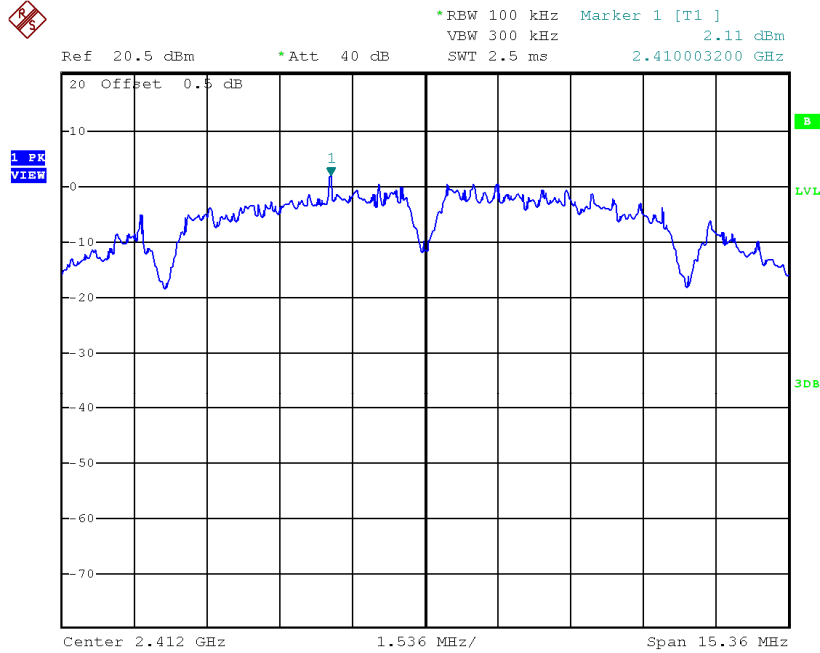

Date: 8.NOV.2016 10:02:43

802.11b, Middle channel

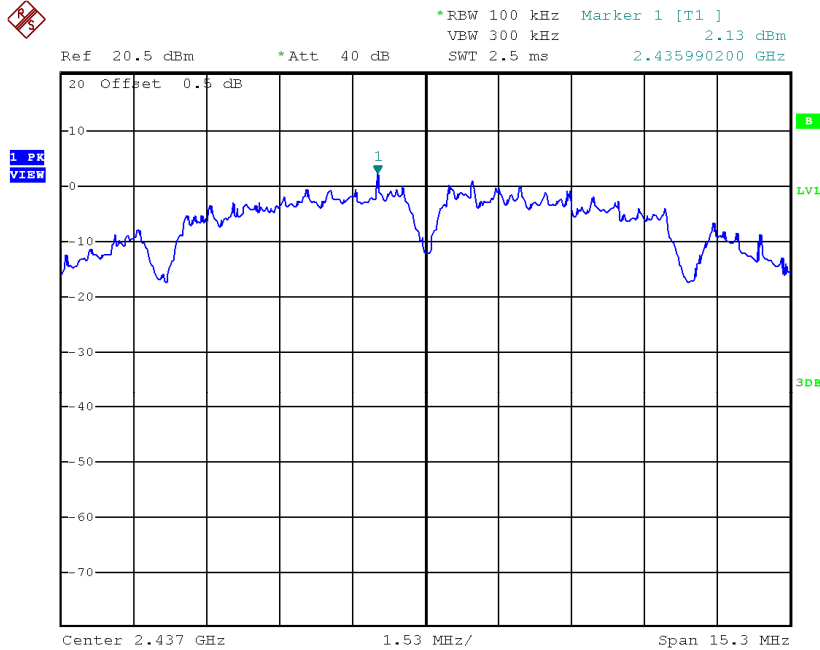

Date: 8.NOV.2016 10:07:06

INTERTEK TESTING SERVICES

Plots of power spectral density (Antenna 1) 802.11b, Highest channel

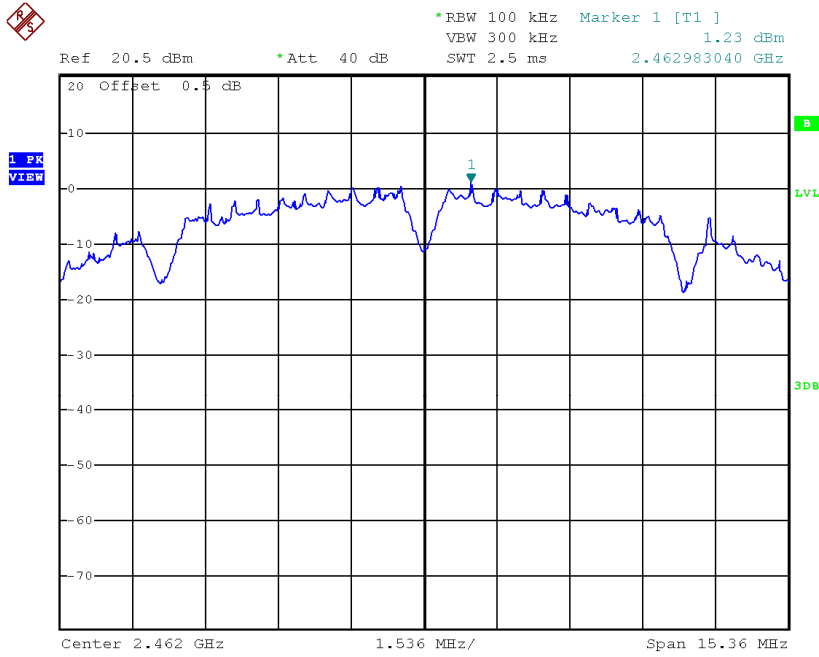

Date: 8.NOV.2016 10:11:58

INTERTEK TESTING SERVICES

Plots of power spectral density (Antenna 2)

802.11b, Lowest channel

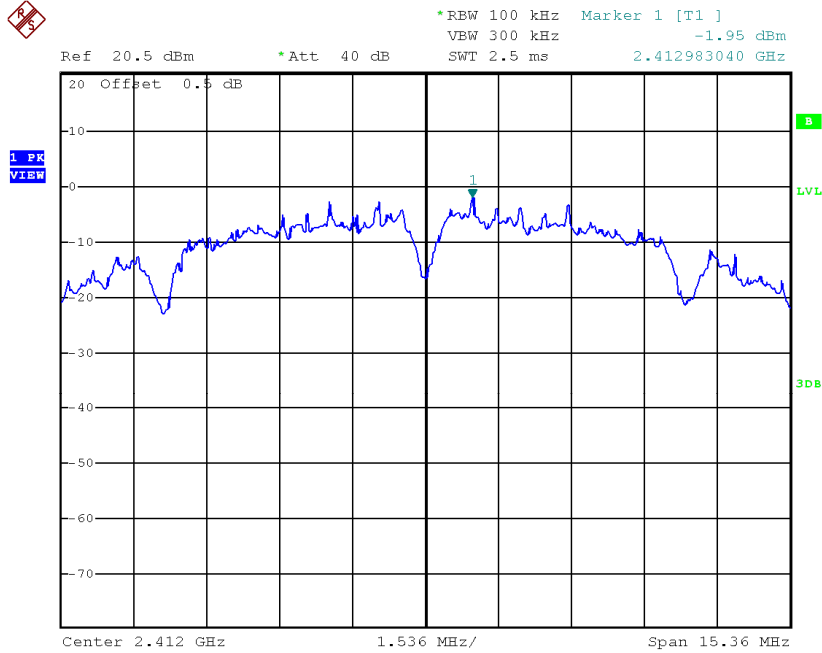

Date: 8.NOV.2016 10:04:10

802.11b, Middle channel

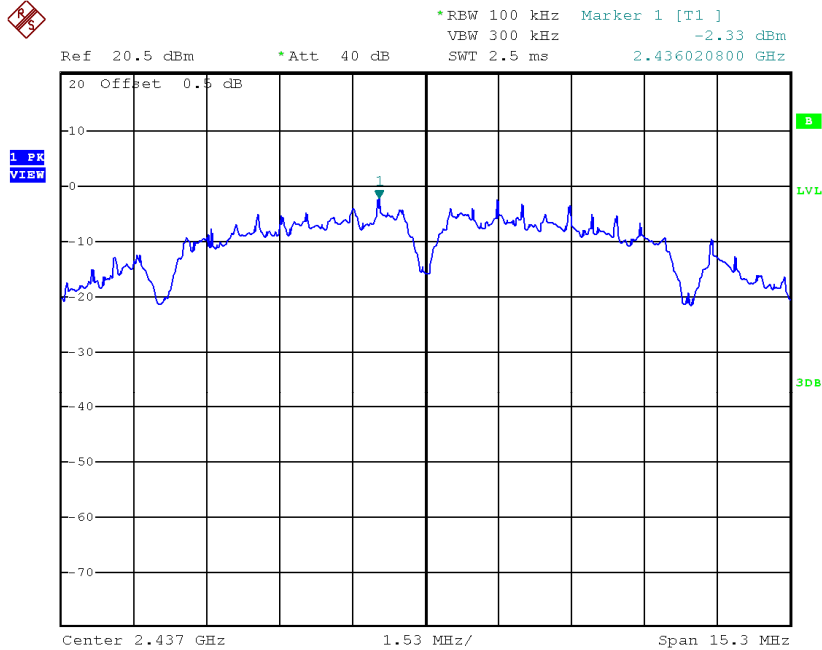

Date: 8.NOV.2016 10:08:48

INTERTEK TESTING SERVICES

Plots of power spectral density (Antenna 2) 802.11b, Highest channel

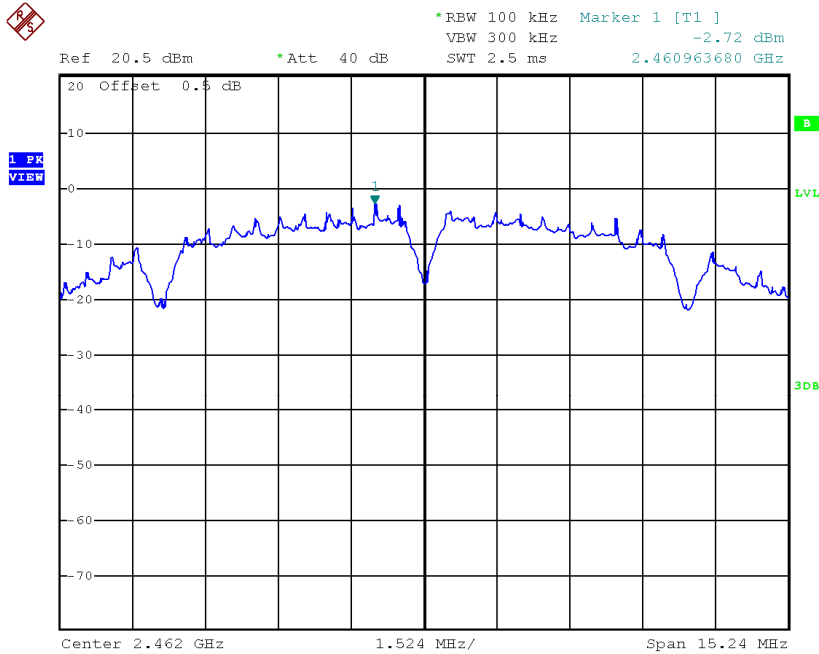

Date: 8.NOV.2016 10:14:03

INTERTEK TESTING SERVICES

4.4 Out of Band Conducted Emissions

For 802.11b:

The maximum conducted (peak) output power was used to demonstrate compliance as described in 9.1. Then the display line (in red) shown in the following plots denotes the limit at 20dB below maximum measured in-band peak PSD level in 100 KHz bandwidth.

The measurement procedures under sections 11 of KDB558074 D01 v03r05 (08-April-2016) were used.

Furthermore, delta measurement technique for measuring bandedge emissions was incorporated in the test of the edge at 2483.5MHz.

Limits:

For 802.11 b

All spurious emission and up to the tenth harmonic was measured and they were found to be at least 20 dB below the maximum measured in-band peak PSD level.

The plots of out of band conducted emissions are as below.

INTERTEK TESTING SERVICES

Plots of out of band conducted emissions (Antenna 1) 802.11b, Lowest Channel, Plot A

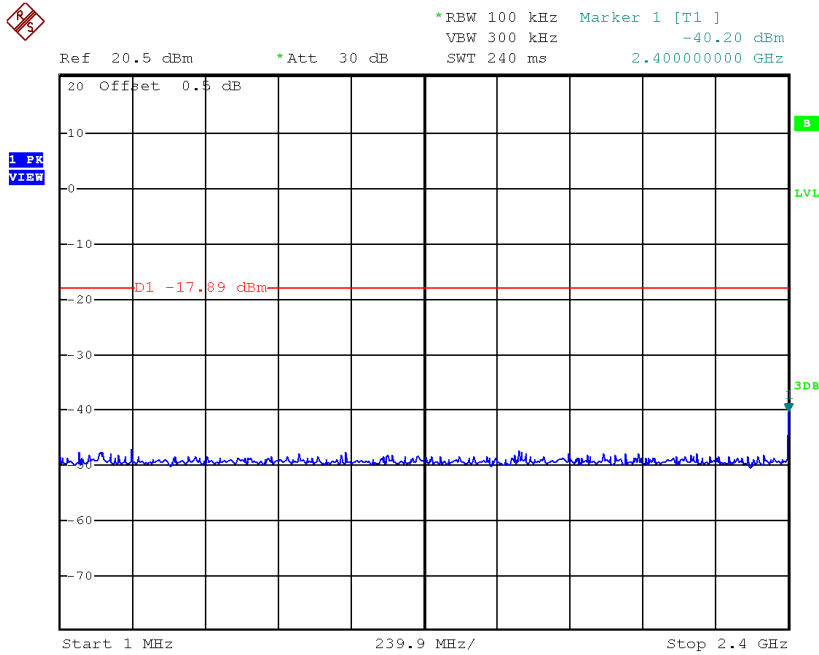

Date: 8.NOV.2016 10:55:02

802.11b, Lowest Channel, Plot B

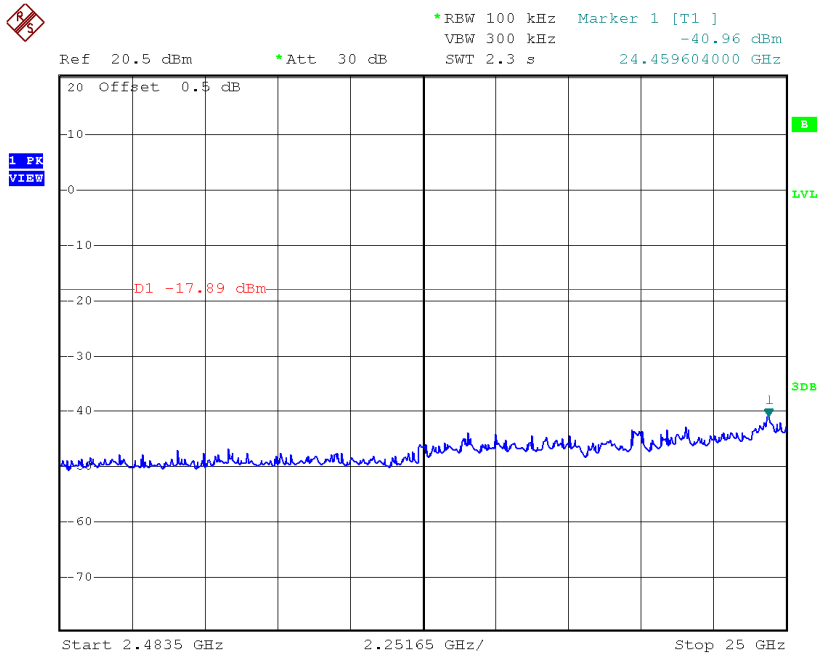

Date: 8.NOV.2016 18:15:39

INTERTEK TESTING SERVICES

Plots of out of band conducted emissions (Antenna 1)

802.11b, Middle Channel, Plot A

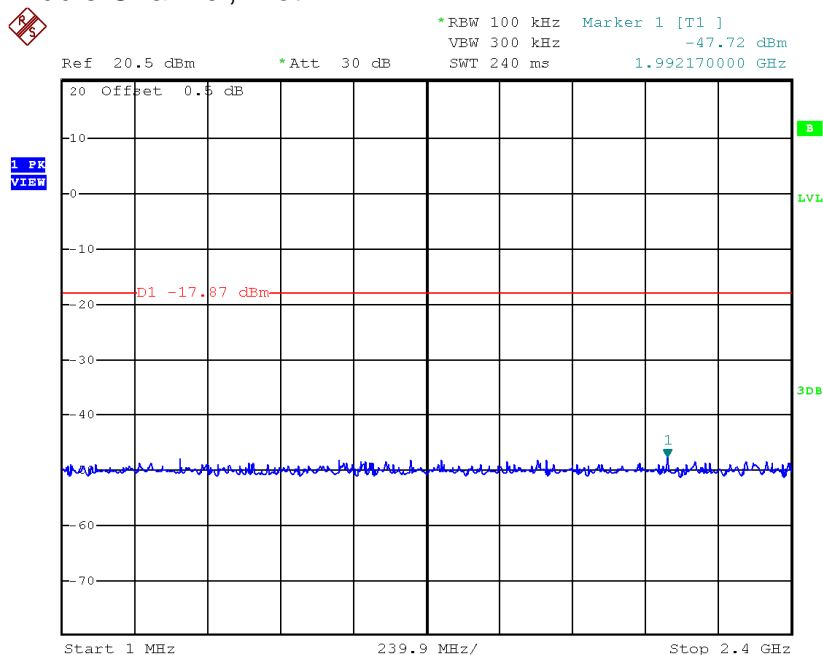

Date: 8.NOV.2016 11:01:25

802.11b, Middle Channel, Plot B

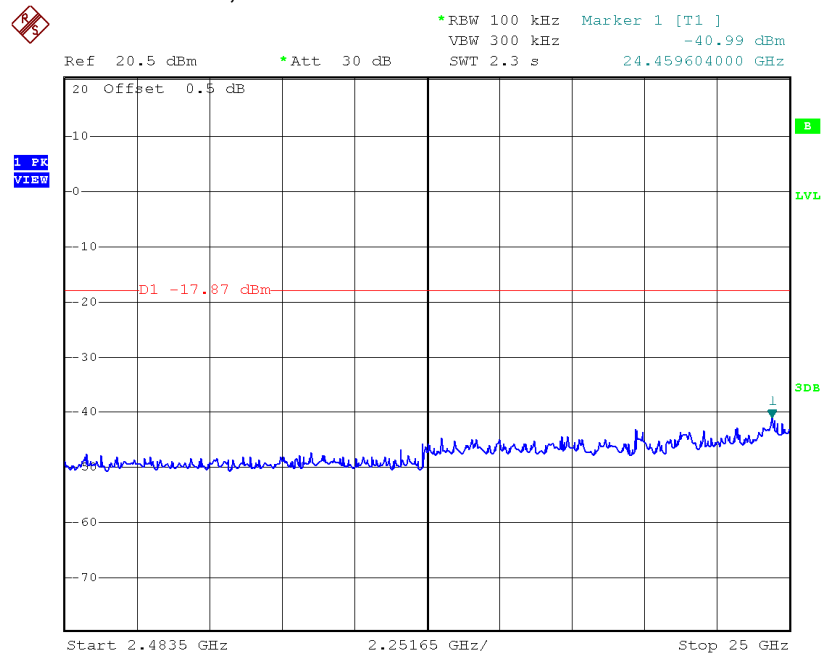

Date: 8.NOV.2016 18:11:11

INTERTEK TESTING SERVICES

Plots of out of band conducted emissions (Antenna 1)

802.11b, Highest Channel, Plot A

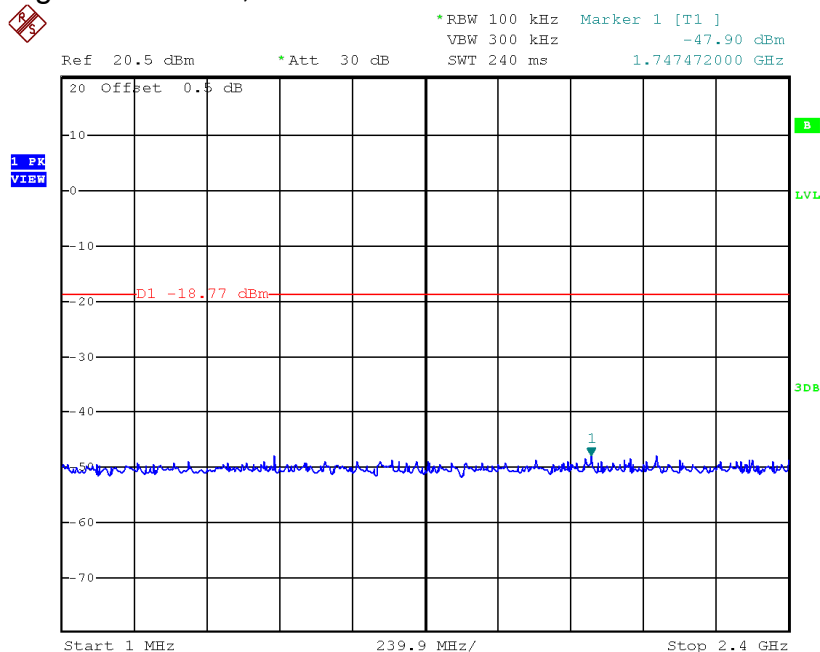

Date: 8.NOV.2016 11:04:04

802.11b, Highest Channel, Plot B

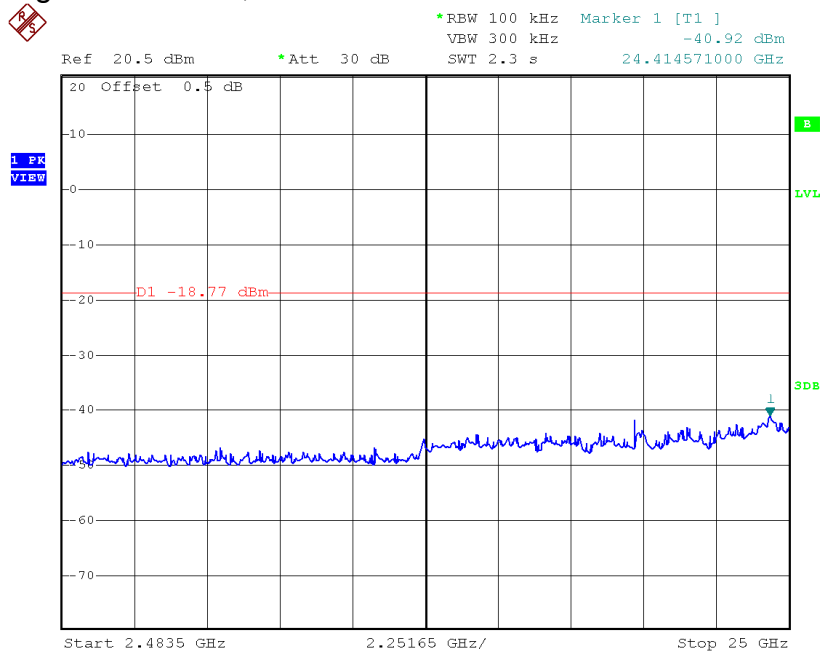

Date: 8.NOV.2016 18:05:18

INTERTEK TESTING SERVICES

Plots of out of band conducted emissions (Antenna 2) 802.11b, Lowest Channel, Plot A

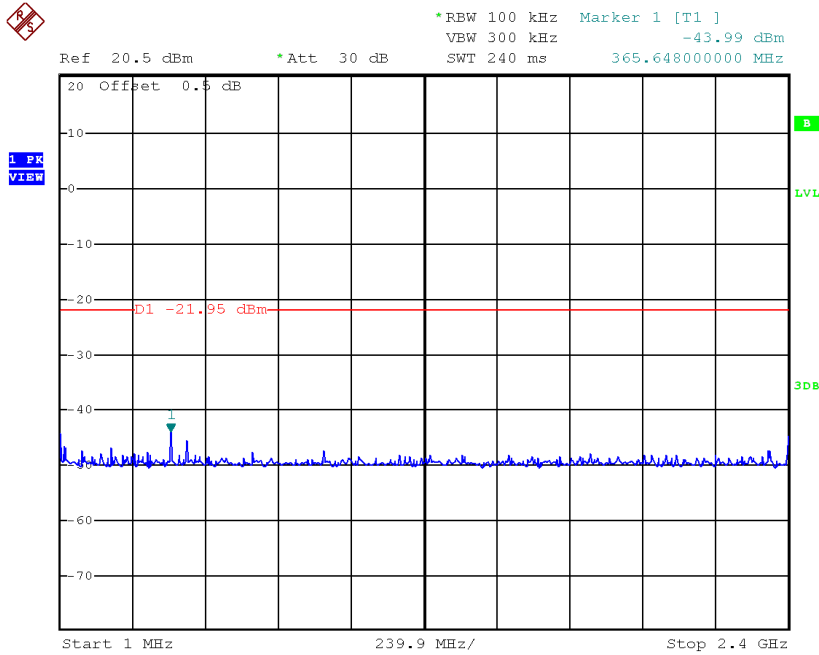

Date: 8.NOV.2016 10:58:47

802.11b, Lowest Channel, Plot B

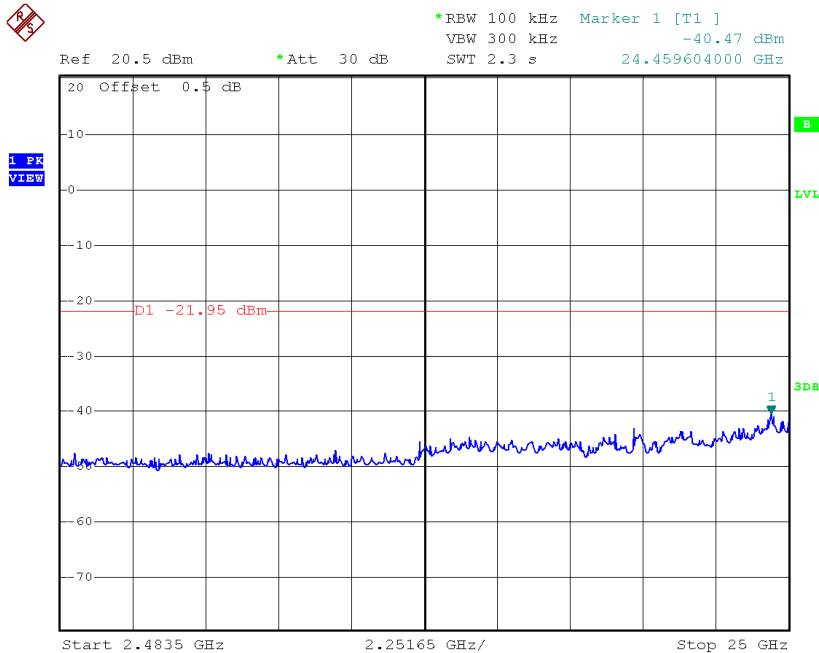

Date: 8.NOV.2016 18:09:51

INTERTEK TESTING SERVICES

Plots of out of band conducted emissions (Antenna 2)

802.11b, Middle Channel, Plot A

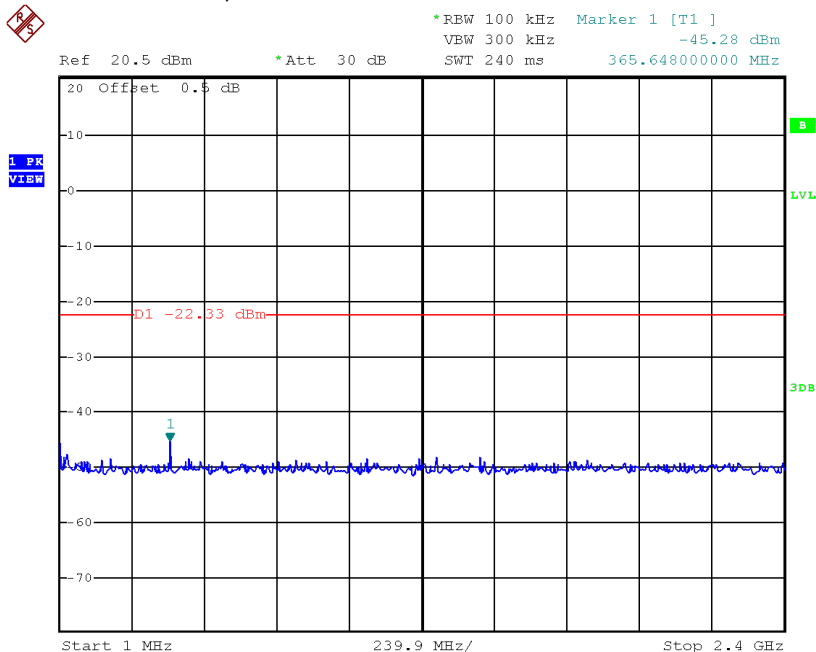

Date: 8.NOV.2016 11:02:21

802.11b, Middle Channel, Plot B

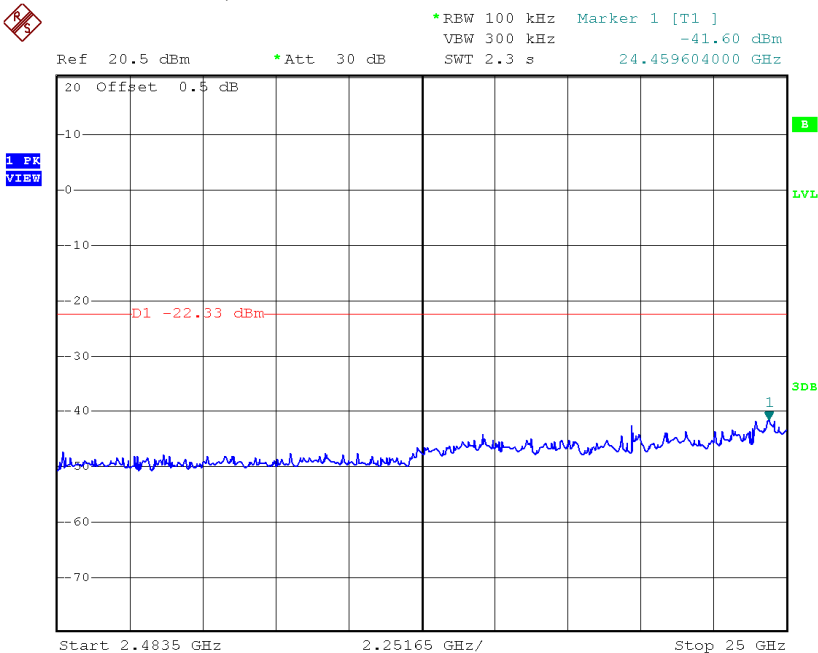

Date: 8.NOV.2016 18:08:30

INTERTEK TESTING SERVICES

Plots of out of band conducted emissions (Antenna 2)

802.11b, Highest Channel, Plot A

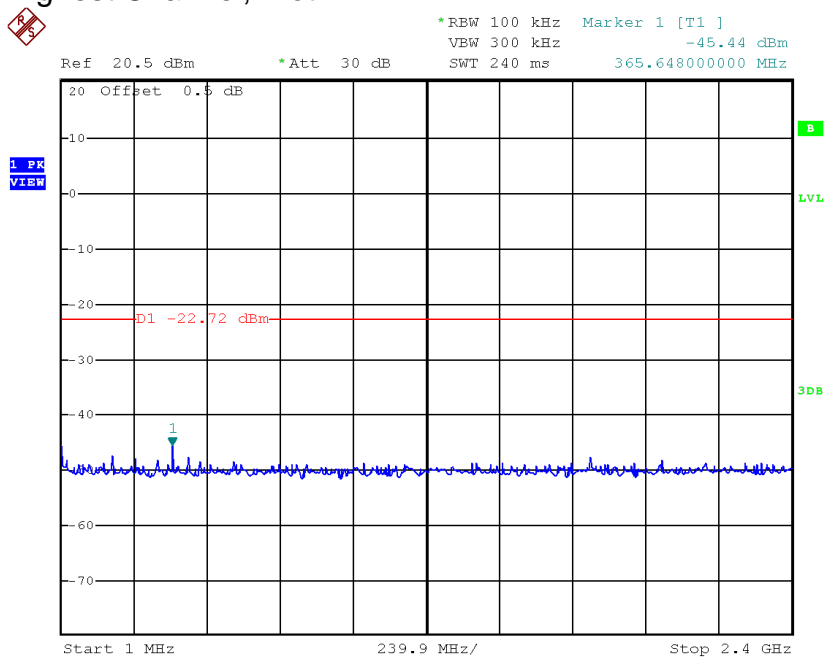

Date: 8.NOV.2016 11:05:10

802.11b, Highest Channel, Plot B

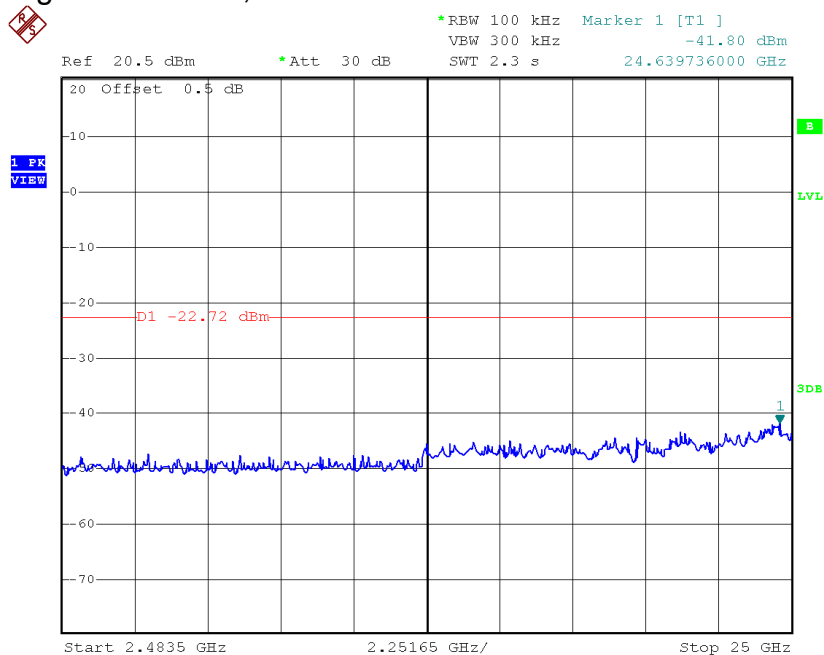

Date: 8.NOV.2016 18:07:32

INTERTEK TESTING SERVICES

Plots of Bandedge (Antenna 1)

802.11b, Lowest Channel

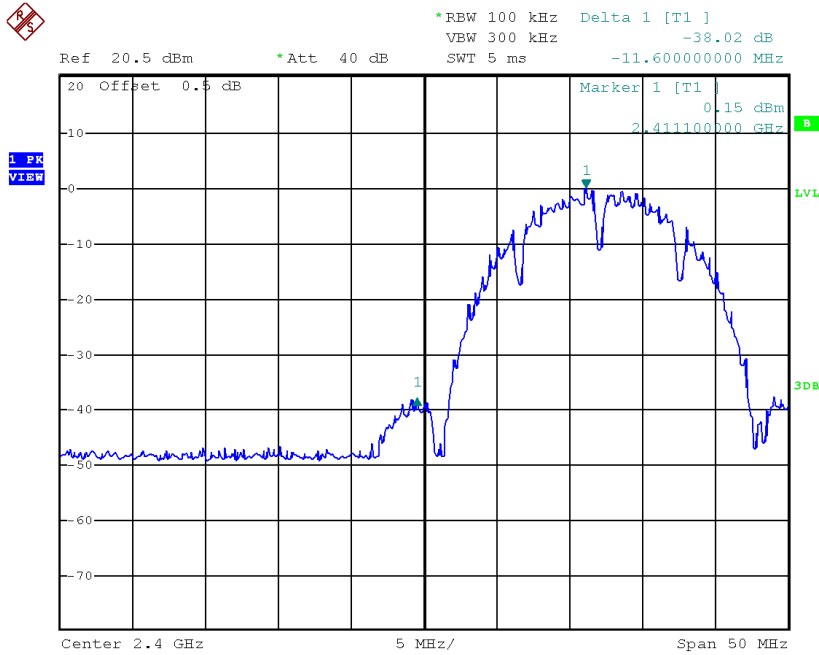

Date: 8.NOV.2016 10:45:07

802.11b, Highest Channel

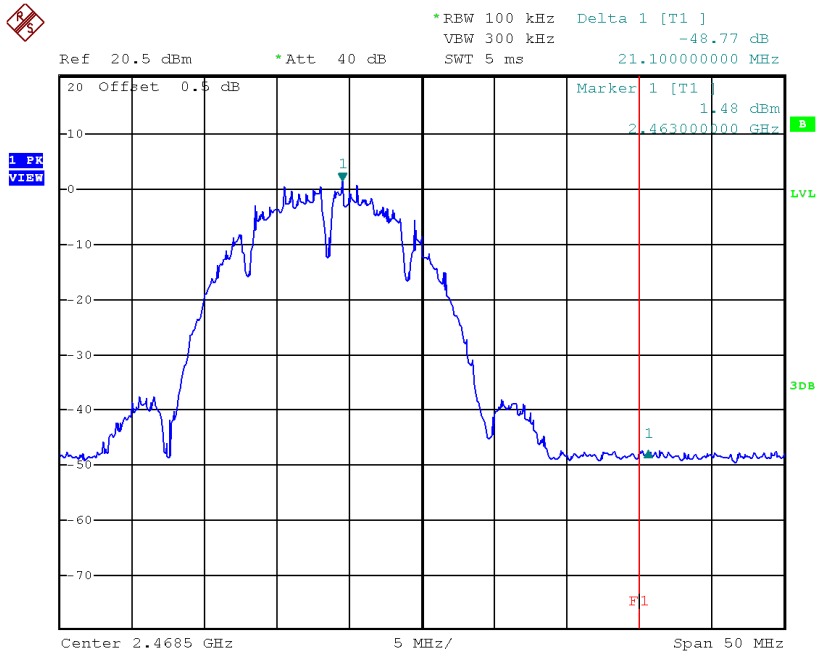

Date: 8.NOV.2016 10:17:59

INTERTEK TESTING SERVICES

Plots of Bandedge (Antenna 2)

802.11b, Lowest Channel

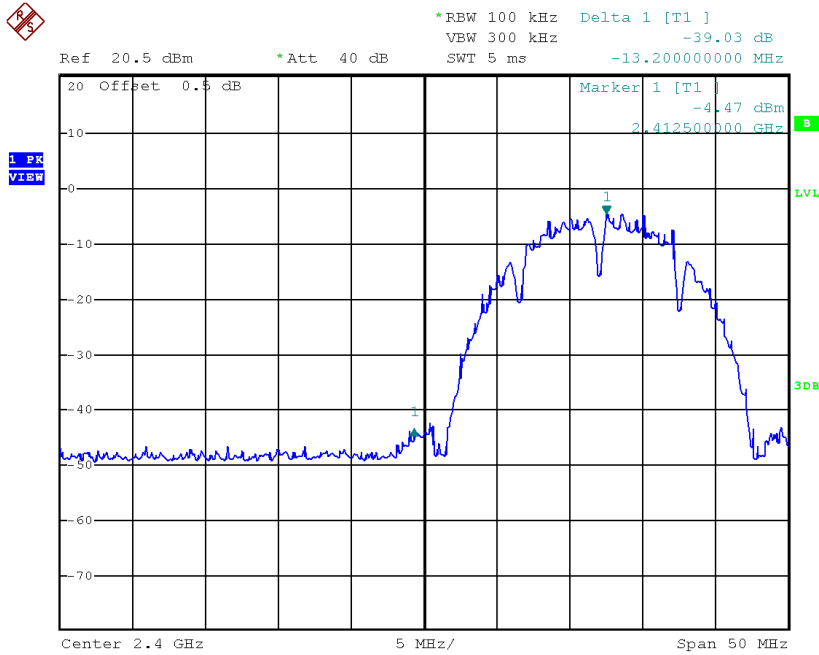

Date: 8.NOV.2016 10:28:53

802.11b, Highest Channel

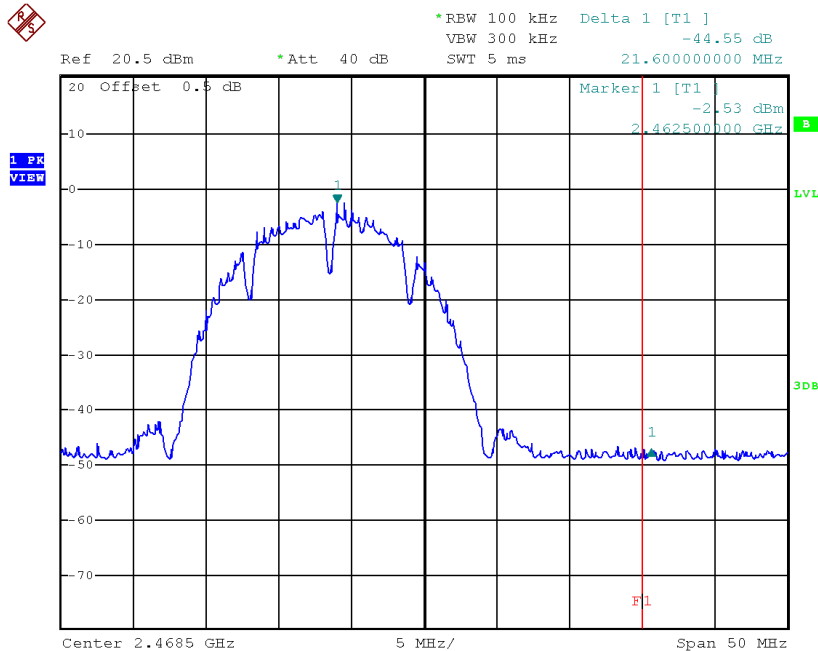

Date: 8.NOV.2016 10:21:18

INTERTEK TESTING SERVICES

4.5 Field Strength Calculation

The field strength is calculated by adding the reading on the Spectrum Analyzer to the factors associated with preamplifiers (if any), antennas, cables, pulse desensitization and average factors (when specified limit is in average and measurements are made with peak detectors). A sample calculation is included below.

$$FS = RA + AF + CF - AG + PD + AV$$

Where

- FS = Field Strength in dB μ V/m
- RA = Receiver Amplitude (including preamplifier) in dB μ V
- CF = Cable Attenuation Factor in dB
- AF = Antenna Factor in dB
- AG = Amplifier Gain in dB
- PD = Pulse Desensitization in dB
- AV = Average Factor in -dB

In the radiated emission table which follows, the reading shown on the data table may reflect the preamplifier gain. An example of the calculations, where the reading does not reflect the preamplifier gain, follows:

$$FS = RA + AF + CF - AG + PD + AV$$

Example

Assume a receiver reading of 62.0 dB μ V is obtained. The antenna factor of 7.4 dB and cable factor of 1.6 dB is added. The amplifier gain of 29.0 dB is subtracted. The pulse desensitization factor of the spectrum analyzer is 0.0 dB, and the resultant average factor is -10.0 dB. The net field strength for comparison to the appropriate emission limit is 32.0 dB μ V/m. This value in dB μ V/m is converted to its corresponding level in μ V/m.

RA = 62.0 dB μ V
AF = 7.4 dB
CF = 1.6 dB
AG = 29.0 dB
PD = 0.0 dB
AV = -10 dB

$$FS = 62.0 + 7.4 + 1.6 - 29.0 + 0.0 + (-10.0) = 32.0 \text{ dB}\mu\text{V/m}$$

$$\text{Level in } \mu\text{V/m} = \text{Common Antilogarithm} [(32.0 \text{ dB}\mu\text{V/m})/20] = 39.8 \mu\text{V/m}$$

INTERTEK TESTING SERVICES

4.6 Transmitter Radiated Emissions in Restricted Bands and Spurious Emissions

Data is included of the worst case configuration (the configuration which resulted in the highest emission levels). A sample calculation, configuration photographs and data tables of the emissions are included.

The data on the following pages list the significant emission frequencies, the limit and the margin of compliance.

4.6.1 Radiated Emission Configuration Photograph

Worst Case Restricted Band Radiated Emission
at

761.860 MHz

The worst case radiated emission configuration photographs are saved with filename:
config photos.pdf

4.6.2 Radiated Emission Data

The data in tables 1-4 list the significant emission frequencies, the limit and the margin of compliance.

Judgement -

Passed by 2.2 dB margin

INTERTEK TESTING SERVICES

Mode: TX-Channel 01

Date of Test: December 11, 2016

Table 1
IEEE 802.11b (DSSS, 1 Mbps) (Antenna 1)

Radiated Emission Data

Polarization	Frequency (MHz)	Reading (dBuV)	Pre-Amp Gain (dB)	Antenna Factor (dB)	Net at 3m (dBuV/m)	Average Limit at 3m (dBuV/m)	Margin (dB)
<i>H</i>	<i>2390.000</i>	<i>52.2</i>	<i>33</i>	<i>29.4</i>	<i>48.6</i>	<i>54.0</i>	<i>-5.4</i>
<i>V</i>	<i>4824.000</i>	<i>38.1</i>	<i>33</i>	<i>34.9</i>	<i>40.0</i>	<i>54.0</i>	<i>-14.0</i>
<i>H</i>	<i>12060.000</i>	<i>39.3</i>	<i>33</i>	<i>40.5</i>	<i>46.8</i>	<i>54.0</i>	<i>-7.2</i>

Polarization	Frequency (MHz)	Reading (dBuV)	Pre-Amp Gain (dB)	Antenna Factor (dB)	Net at 3m - Peak (dBuV/m)	Peak Limit at 3m (dBuV/m)	Margin (dB)
<i>H</i>	<i>2390.000</i>	<i>64.6</i>	<i>33</i>	<i>29.4</i>	<i>61.0</i>	<i>74.0</i>	<i>-13.0</i>
<i>V</i>	<i>4824.000</i>	<i>44.0</i>	<i>33</i>	<i>34.9</i>	<i>45.9</i>	<i>74.0</i>	<i>-28.1</i>
<i>H</i>	<i>12060.000</i>	<i>45.9</i>	<i>33</i>	<i>40.5</i>	<i>53.4</i>	<i>74.0</i>	<i>-20.6</i>

- NOTES:
1. Peak detector is used for the peak emission measurement.
 2. Average measurement method is according to ANSI C63.10
 3. All measurements were made at 3 meters. Radiated emissions not detected at the 3-meter distance were measured at 0.3-meter and an inverse proportional extrapolation was performed to compare the signal level to the 3-meter limit. No other radiated emissions than those reported were detected at a test distance of 0.3-meter.
 4. Negative value in the margin column shows emission below limit.
 5. Horn antenna is used for the emission over 1000MHz.
 6. Emission (the row indicated by ***bold italic***) within the restricted band meets the requirement of FCC Part 15 Section 15.205.
 7. For the measurement of radiated emission, summation method was used which numerical integrating (in terms of linear power) over the transmitter occupied bandwidth.
 8. For the linear power measurement, data in 1MHz spacing was collected by spectrum analyzer with 1MHz resolution bandwidth.

INTERTEK TESTING SERVICES

Mode: TX-Channel 06

Date of Test: December 11, 2016

Table 2
IEEE 802.11b (DSSS, 1 Mbps) (Antenna 1)

Radiated Emission Data

Polarization	Frequency	Reading (dBuV)	Pre-Amp Gain (dB)	Antenna Factor (dB)	Net at 3m (dBuV/m)	Average Limit at 3m (dBuV/m)	Margin (dB)
V	4874.000	38.3	33	34.9	40.2	54.0	-13.8
H	7311.000	38.0	33	37.9	42.9	54.0	-11.1
H	12185.000	39.2	33	40.5	46.7	54.0	-7.3

Polarization	Frequency	Reading (dBuV)	Pre-Amp Gain (dB)	Antenna Factor (dB)	Net at 3m - Peak (dBuV/m)	Peak Limit at 3m (dBuV/m)	Margin (dB)
V	4874.000	43.8	33	34.9	45.7	74.0	-28.3
H	7311.000	42.4	33	37.9	47.3	74.0	-26.7
H	12185.000	46.0	33	40.5	53.5	74.0	-20.5

- NOTES:
1. Peak detector is used for the peak emission measurement.
 2. Average measurement method is according to ANSI C63.10
 3. All measurements were made at 3 meters. Radiated emissions not detected at the 3-meter distance were measured at 0.3-meter and an inverse proportional extrapolation was performed to compare the signal level to the 3-meter limit. No other radiated emissions than those reported were detected at a test distance of 0.3-meter.
 4. Negative value in the margin column shows emission below limit.
 5. Horn antenna is used for the emission over 1000MHz.
 6. Emission (the row indicated by **bold italic**) within the restricted band meets the requirement of FCC Part 15 Section 15.205.
 7. For the measurement of radiated emission, summation method was used which numerical integrating (in terms of linear power) over the transmitter occupied bandwidth.
 8. For the linear power measurement, data in 1MHz spacing was collected by spectrum analyzer with 1MHz resolution bandwidth.

INTERTEK TESTING SERVICES

Mode: TX-Channel 11

Date of Test: December 11, 2016

Table 3
IEEE 802.11b (DSSS, 1 Mbps) (Antenna 1)

Radiated Emission Data

Polarization	Frequency	Reading (dBuV)	Pre-Amp Gain (dB)	Antenna Factor (dB)	Net at 3m (dBuV/m)	Average Limit at 3m (dBuV/m)	Margin (dB)
<i>V</i>	<i>2483.500</i>	<i>54.2</i>	<i>33</i>	<i>29.4</i>	<i>50.6</i>	<i>54.0</i>	<i>-3.4</i>
<i>V</i>	<i>4924.000</i>	<i>38.4</i>	<i>33</i>	<i>34.9</i>	<i>40.3</i>	<i>54.0</i>	<i>-13.7</i>
<i>H</i>	<i>7386.000</i>	<i>37.9</i>	<i>33</i>	<i>37.9</i>	<i>42.8</i>	<i>54.0</i>	<i>-11.2</i>
<i>H</i>	<i>12310.000</i>	<i>38.9</i>	<i>33</i>	<i>40.5</i>	<i>46.4</i>	<i>54.0</i>	<i>-7.6</i>

Polarization	Frequency	Reading (dBuV)	Pre-Amp Gain (dB)	Antenna Factor (dB)	Net at 3m - Peak (dBuV/m)	Peak Limit at 3m (dBuV/m)	Margin (dB)
<i>V</i>	<i>2483.500</i>	<i>63.9</i>	<i>33</i>	<i>29.4</i>	<i>60.3</i>	<i>74.0</i>	<i>-13.7</i>
<i>V</i>	<i>4924.000</i>	<i>43.6</i>	<i>33</i>	<i>34.9</i>	<i>45.5</i>	<i>74.0</i>	<i>-28.5</i>
<i>H</i>	<i>7386.000</i>	<i>42.7</i>	<i>33</i>	<i>37.9</i>	<i>47.6</i>	<i>74.0</i>	<i>-26.4</i>
<i>H</i>	<i>12310.000</i>	<i>45.8</i>	<i>33</i>	<i>40.5</i>	<i>53.3</i>	<i>74.0</i>	<i>-20.7</i>

- NOTES:
1. Peak detector is used for the peak emission measurement.
 2. Average measurement method is according to ANSI C63.10
 3. All measurements were made at 3 meters. Radiated emissions not detected at the 3-meter distance were measured at 0.3-meter and an inverse proportional extrapolation was performed to compare the signal level to the 3-meter limit. No other radiated emissions than those reported were detected at a test distance of 0.3-meter.
 4. Negative value in the margin column shows emission below limit.
 5. Horn antenna is used for the emission over 1000MHz.
 6. Emission (the row indicated by ***bold italic***) within the restricted band meets the requirement of FCC Part 15 Section 15.205.
 7. For the measurement of radiated emission, summation method was used which numerical integrating (in terms of linear power) over the transmitter occupied bandwidth.
 8. For the linear power measurement, data in 1MHz spacing was collected by spectrum analyzer with 1MHz resolution bandwidth.

INTERTEK TESTING SERVICES

Mode: TX-Channel 01

Date of Test: December 11, 2016

Table 4
IEEE 802.11b (DSSS, 1 Mbps) (Antenna 2)

Radiated Emission Data

Polarization	Frequency (MHz)	Reading (dBuV)	Pre-Amp Gain (dB)	Antenna Factor (dB)	Net at 3m (dBuV/m)	Average Limit at 3m (dBuV/m)	Margin (dB)
<i>H</i>	<i>2390.000</i>	<i>52.2</i>	<i>33</i>	<i>29.4</i>	<i>48.6</i>	<i>54.0</i>	<i>-5.4</i>
<i>V</i>	<i>4824.000</i>	<i>38.1</i>	<i>33</i>	<i>34.9</i>	<i>40.0</i>	<i>54.0</i>	<i>-14.0</i>
<i>H</i>	<i>12060.000</i>	<i>39.3</i>	<i>33</i>	<i>40.5</i>	<i>46.8</i>	<i>54.0</i>	<i>-7.2</i>

Polarization	Frequency (MHz)	Reading (dBuV)	Pre-Amp Gain (dB)	Antenna Factor (dB)	Net at 3m - Peak (dBuV/m)	Peak Limit at 3m (dBuV/m)	Margin (dB)
<i>H</i>	<i>2390.000</i>	<i>64.6</i>	<i>33</i>	<i>29.4</i>	<i>61.0</i>	<i>74.0</i>	<i>-13.0</i>
<i>V</i>	<i>4824.000</i>	<i>44.0</i>	<i>33</i>	<i>34.9</i>	<i>45.9</i>	<i>74.0</i>	<i>-28.1</i>
<i>H</i>	<i>12060.000</i>	<i>45.9</i>	<i>33</i>	<i>40.5</i>	<i>53.4</i>	<i>74.0</i>	<i>-20.6</i>

- NOTES:
1. Peak detector is used for the peak emission measurement.
 2. Average measurement method is according to ANSI C63.10
 3. All measurements were made at 3 meters. Radiated emissions not detected at the 3-meter distance were measured at 0.3-meter and an inverse proportional extrapolation was performed to compare the signal level to the 3-meter limit. No other radiated emissions than those reported were detected at a test distance of 0.3-meter.
 4. Negative value in the margin column shows emission below limit.
 5. Horn antenna is used for the emission over 1000MHz.
 6. Emission (the row indicated by ***bold italic***) within the restricted band meets the requirement of FCC Part 15 Section 15.205.
 7. For the measurement of radiated emission, summation method was used which numerical integrating (in terms of linear power) over the transmitter occupied bandwidth.
 8. For the linear power measurement, data in 1MHz spacing was collected by spectrum analyzer with 1MHz resolution bandwidth.

INTERTEK TESTING SERVICES

Mode: TX-Channel 06

Date of Test: December 11, 2016

Table 5
IEEE 802.11b (DSSS, 1 Mbps) (Antenna 2)

Radiated Emission Data

Polarization	Frequency	Reading (dBuV)	Pre-Amp Gain (dB)	Antenna Factor (dB)	Net at 3m (dBuV/m)	Average Limit at 3m (dBuV/m)	Margin (dB)
<i>V</i>	<i>4874.000</i>	<i>38.3</i>	<i>33</i>	<i>34.9</i>	<i>40.2</i>	<i>54.0</i>	<i>-13.8</i>
<i>H</i>	<i>7311.000</i>	<i>38.0</i>	<i>33</i>	<i>37.9</i>	<i>42.9</i>	<i>54.0</i>	<i>-11.1</i>
<i>H</i>	<i>12185.000</i>	<i>39.2</i>	<i>33</i>	<i>40.5</i>	<i>46.7</i>	<i>54.0</i>	<i>-7.3</i>

Polarization	Frequency	Reading (dBuV)	Pre-Amp Gain (dB)	Antenna Factor (dB)	Net at 3m - Peak (dBuV/m)	Peak Limit at 3m (dBuV/m)	Margin (dB)
<i>V</i>	<i>4874.000</i>	<i>43.8</i>	<i>33</i>	<i>34.9</i>	<i>45.7</i>	<i>74.0</i>	<i>-28.3</i>
<i>H</i>	<i>7311.000</i>	<i>42.4</i>	<i>33</i>	<i>37.9</i>	<i>47.3</i>	<i>74.0</i>	<i>-26.7</i>
<i>H</i>	<i>12185.000</i>	<i>46.0</i>	<i>33</i>	<i>40.5</i>	<i>53.5</i>	<i>74.0</i>	<i>-20.5</i>

- NOTES:
1. Peak detector is used for the peak emission measurement.
 2. Average measurement method is according to ANSI C63.10
 3. All measurements were made at 3 meters. Radiated emissions not detected at the 3-meter distance were measured at 0.3-meter and an inverse proportional extrapolation was performed to compare the signal level to the 3-meter limit. No other radiated emissions than those reported were detected at a test distance of 0.3-meter.
 4. Negative value in the margin column shows emission below limit.
 5. Horn antenna is used for the emission over 1000MHz.
 6. Emission (the row indicated by ***bold italic***) within the restricted band meets the requirement of FCC Part 15 Section 15.205.
 7. For the measurement of radiated emission, summation method was used which numerical integrating (in terms of linear power) over the transmitter occupied bandwidth.
 8. For the linear power measurement, data in 1MHz spacing was collected by spectrum analyzer with 1MHz resolution bandwidth.

INTERTEK TESTING SERVICES

Mode: TX-Channel 11

Date of Test: December 11, 2016

Table 6
IEEE 802.11b (DSSS, 1 Mbps) (Antenna 2)

Radiated Emission Data

Polarization	Frequency	Reading (dBuV)	Pre-Amp Gain (dB)	Antenna Factor (dB)	Net at 3m (dBuV/m)	Average Limit at 3m (dBuV/m)	Margin (dB)
<i>V</i>	<i>2483.500</i>	<i>54.2</i>	<i>33</i>	<i>29.4</i>	<i>50.6</i>	<i>54.0</i>	<i>-3.4</i>
<i>V</i>	<i>4924.000</i>	<i>38.4</i>	<i>33</i>	<i>34.9</i>	<i>40.3</i>	<i>54.0</i>	<i>-13.7</i>
<i>H</i>	<i>7386.000</i>	<i>37.9</i>	<i>33</i>	<i>37.9</i>	<i>42.8</i>	<i>54.0</i>	<i>-11.2</i>
<i>H</i>	<i>12310.000</i>	<i>38.9</i>	<i>33</i>	<i>40.5</i>	<i>46.4</i>	<i>54.0</i>	<i>-7.6</i>

Polarization	Frequency	Reading (dBuV)	Pre-Amp Gain (dB)	Antenna Factor (dB)	Net at 3m - Peak (dBuV/m)	Peak Limit at 3m (dBuV/m)	Margin (dB)
<i>V</i>	<i>2483.500</i>	<i>63.9</i>	<i>33</i>	<i>29.4</i>	<i>60.3</i>	<i>74.0</i>	<i>-13.7</i>
<i>V</i>	<i>4924.000</i>	<i>43.6</i>	<i>33</i>	<i>34.9</i>	<i>45.5</i>	<i>74.0</i>	<i>-28.5</i>
<i>H</i>	<i>7386.000</i>	<i>42.7</i>	<i>33</i>	<i>37.9</i>	<i>47.6</i>	<i>74.0</i>	<i>-26.4</i>
<i>H</i>	<i>12310.000</i>	<i>45.8</i>	<i>33</i>	<i>40.5</i>	<i>53.3</i>	<i>74.0</i>	<i>-20.7</i>

- NOTES:
1. Peak detector is used for the peak emission measurement.
 2. Average measurement method is according to ANSI C63.10
 3. All measurements were made at 3 meters. Radiated emissions not detected at the 3-meter distance were measured at 0.3-meter and an inverse proportional extrapolation was performed to compare the signal level to the 3-meter limit. No other radiated emissions than those reported were detected at a test distance of 0.3-meter.
 4. Negative value in the margin column shows emission below limit.
 5. Horn antenna is used for the emission over 1000MHz.
 6. Emission (the row indicated by ***bold italic***) within the restricted band meets the requirement of FCC Part 15 Section 15.205.
 7. For the measurement of radiated emission, summation method was used which numerical integrating (in terms of linear power) over the transmitter occupied bandwidth.
 8. For the linear power measurement, data in 1MHz spacing was collected by spectrum analyzer with 1MHz resolution bandwidth.

INTERTEK TESTING SERVICES

Worst Case: Normal Operation with WiFi On
 Date of Test: December 11, 2016

Table 7

Radiated Emission Data

Polarization	Frequency (MHz)	Reading (dB μ V)	Pre-amp (dB)	Antenna Factor (dB)	Net at 3m (dB μ V/m)	Limit at 3m (dB μ V/m)	Margin (dB)
V	31.320	40.4	16	10.0	34.4	40.0	-5.6
V	64.078	42.7	16	9.0	35.7	40.0	-4.3
H	111.727	36.6	16	14.0	34.6	43.5	-8.9
V	122.870	38.0	16	14.0	36.0	43.5	-7.5
V	171.975	34.5	16	18.0	36.5	43.5	-7.0
H	221.086	37.8	16	17.0	38.8	46.0	-7.2
H	270.431	29.2	16	22.0	35.2	46.0	-10.8
V	368.645	33.9	16	24.0	41.9	46.0	-4.1
V	466.980	29.4	16	26.0	39.4	46.0	-6.6
V	589.933	28.8	16	29.0	41.8	46.0	-4.2
V	614.410	28.1	16	29.0	41.1	46.0	-4.9
V	639.029	28.6	16	29.0	41.6	46.0	-4.4
V	663.660	28.3	16	29.0	41.3	46.0	-4.7
V	712.752	28.5	16	30.0	42.5	46.0	-3.5
V	761.860	29.8	16	30.0	43.8	46.0	-2.2
V	835.577	28.3	16	31.0	43.3	46.0	-2.7
H	960.102	24.9	16	33.0	41.9	54.0	-12.1

- NOTES:
1. Peak detector is used for the emission measurement.
 2. All measurements were made at 3 meters. Radiated emissions not detected at the 3-meter distance were measured at 0.3-meter and an inverse proportional extrapolation was performed to compare the signal level to the 3-meter limit. No other radiated emissions than those reported were detected at a test distance of 0.3-meter.
 3. Negative value in the margin column shows emission below limit.
 4. Emission (the row indicated by **bold italic**) within the restricted band meets the requirement of FCC Part 15 Section 15.205 / RSS-247 Section 3.3.

INTERTEK TESTING SERVICES

Radiated Emission Test Setup

The figure below shows the test setup, which is utilized to make these measurements.

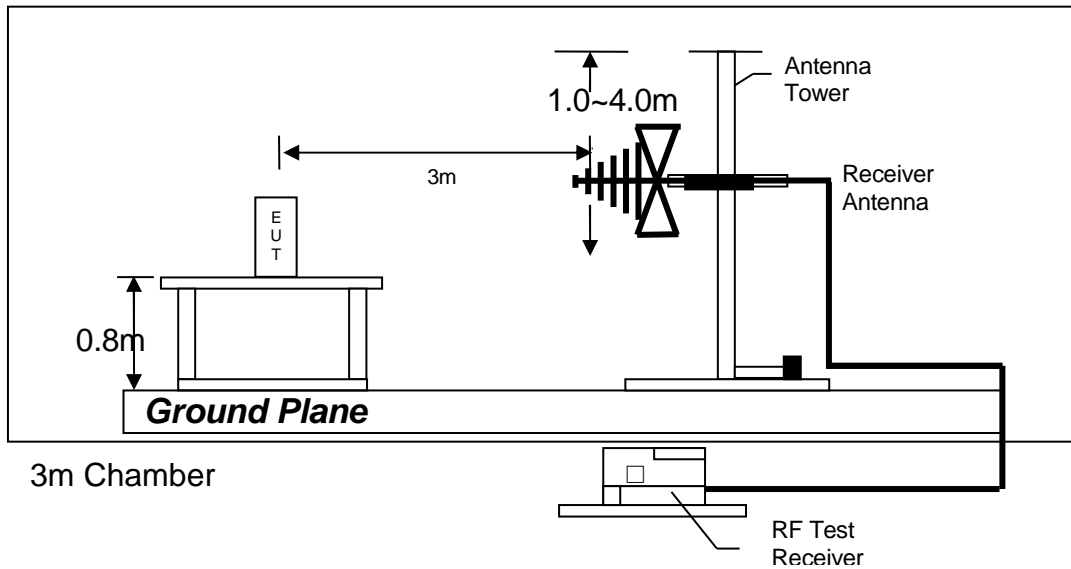

Test setup of radiated emissions up to 1GHz

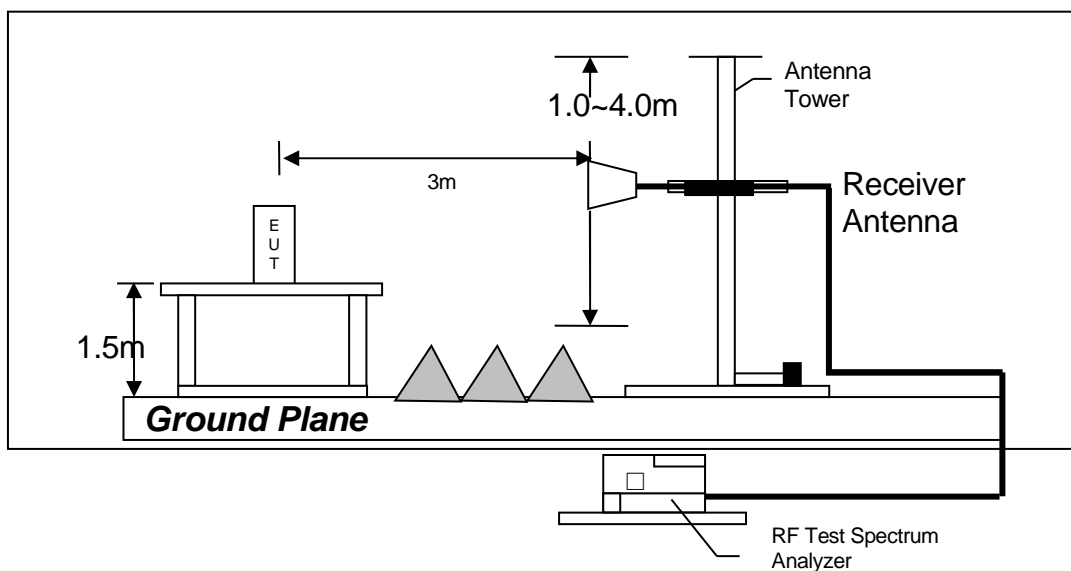

Test setup of radiated emissions above 1GHz

INTERTEK TESTING SERVICES

4.6.3 Transmitter Duty Cycle Calculation

Not applicable – No average factor is required.

4.7 AC Power Line Conducted Emission

- Not applicable – EUT is only powered by battery for operation.
- EUT connects to AC power line. Emission Data is listed in following pages.
- Base Unit connects to AC power line and has transmission. Handset connects to AC power line but has no transmission. Emission Data of Base Unit is listed in following pages.

4.7.1 AC Power Line Conducted Emission Configuration Photograph

Worst Case Line-Conducted Configuration
at

0.722 MHz

The worst case line conducted configuration photographs are attached in the Appendix and saved with filename: config photos.pdf

4.7.2 AC Power Line Conducted Emission Data

The plot(s) and data in the following pages list the significant emission frequencies, the limit and the margin of compliance

Passed by 2.4 dB margin

INTERTEK TESTING SERVICES

Worst Case: Normal Operation with WiFi On

EDIT PEAK LIST (Final Measurement Results)				
Trace1:	CF15MQP			
Trace2:	CF15MAV			
Trace3:	---			
TRACE	FREQUENCY	LEVEL dB μ V		DELTA LIMIT dB
1 Quasi Peak	186 kHz	46.47 N		-17.74
1 Quasi Peak	253.5 kHz	36.98 N		-24.66
1 Quasi Peak	721.5 kHz	43.48 L1		-12.51
2 CISPR Average	721.5 kHz	43.55 N		-2.44
2 CISPR Average	2.166 MHz	29.51 N		-16.48
2 CISPR Average	3.6105 MHz	17.74 N		-28.25
1 Quasi Peak	16.6785 MHz	41.61 L1		-18.38

Date: 13.DEC.2016 20:44:01

INTERTEK TESTING SERVICES

Worst Case: Normal Operation with WiFi On

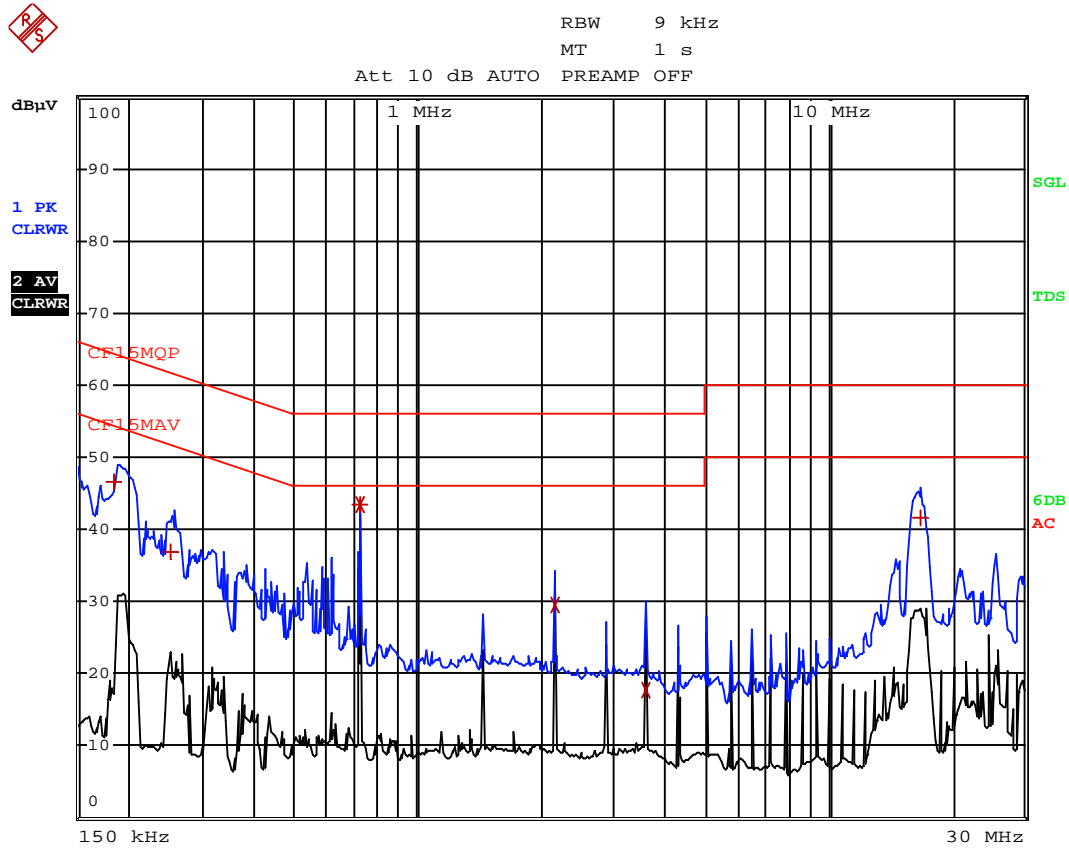

Date: 13.DEC.2016 20:44:20

Conducted Emission Test Setup

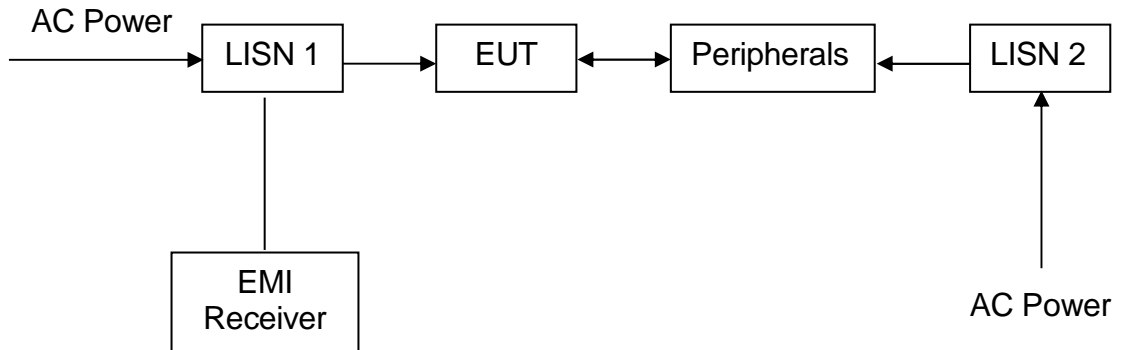

INTERTEK TESTING SERVICES

**EXHIBIT 5
EQUIPMENT LIST**

INTERTEK TESTING SERVICES

5.0 Equipment List

1) Radiated Emissions Test

Equipment	EMI Test Receiver	Spectrum Analyzer	Biconical Antenna
Registration No.	EW-3095	EW-2188	EW-0571
Manufacturer	R&S	AGILENTTECH	EMCO
Model No.	ESCI	E4407B	3104C
Calibration Date	Oct. 25, 2016	Apr. 25, 2016	May. 18, 2016
Calibration Due Date	Oct. 25, 2017	Apr. 25, 2017	Nov. 18, 2017

Equipment	Log Periodic Antenna	Pyramidal Horn Antenna	Double Ridged Guide Antenna
Registration No.	EW-0953	EW-0905	EW-1133
Manufacturer	EMCO	EMCO	EMCO
Model No.	3148	3160-09	3115
Calibration Date	Sep 11, 2015	Feb. 12, 2016	Nov. 05, 2015
Calibration Due Date	Sep 05, 2017	Aug. 12, 2017	May 05, 2017

2) Conducted Emissions Test

Equipment	EMI Test Receiver	LISN
Registration No.	EW-2500	EW-0192
Manufacturer	R&S	R&S
Model No.	ESCI	ESH3-Z5
Calibration Date	Nov. 17, 2016	Aug. 26, 2016
Calibration Due Date	Nov. 17, 2017	Aug. 26, 2017

3) Bandedge/Bandwidth Measurement

Equipment	Spectrum Analyzer
Registration No.	EW-2188
Manufacturer	AGILENTTECH
Model No.	E4407B
Calibration Date	Apr. 25, 2016
Calibration Due Date	Apr. 25, 2017

END OF TEST REPORT