

Tune-Up Procedure

Content

1 PURPOSE.....	1
2 GENERAL DESCRIPTION.....	2
2.1 CHARACTERISTICS OF THE TRANSMIT BURST.....	2
3 PARAMETERS.....	2
3.1 PARAMETERS USED TO SHAPE THE BURST.....	2
3.2 PARAMETERS USED TO DEFINE THE TEMPORAL POSITION OF THE BURST.....	3
3.2.1 Optimum position of the burst.....	3
3.2.2 Optimum length of the burst.....	3
4 OPERATING MODE.....	4
4.1 HOW TO TRANSMIT A TCH BURST (RANDOM DATA), IN GSM850 PCS1900 MODE, AT POWER CONTROL LEVEL MAX:.....	4
4.2 HOW TO STOP TX MEASUREMENTS:.....	4
4.3 HOW TO TRANSMIT A BURST AFTER MODIFYING PARAMETERS.....	4
5 PURPOSE.....	4
6 AUTOMATIC FREQUENCY CONTROL.....	5
7 STATIC FREQUENCY ERROR AND RANGE.....	5
1. BAND PCS1900.....	6
2. BAND GSM850.....	6
GPRS Data Transfer.....	7

1.Purpose

This panel gives the possibility to manage the mobile in the transmit mode. This window includes both:

- All the parameters (frequency band, RF channel, RF level to get the desire antenna output power...) The user needs to make the mobile transmitting, - All the parameters needed to define a transmit burst,
- All the compensation table to be able to align the mobile in production. This Tx_commands user guide is describing:
- The characteristics of the transmit burst,

- All the parameters used in the transmit mode, - The operating mode to make the mobile transmitting

2 · General description

2.1 Characteristics of the transmit burst

The power levels and the shape of a transmit burst are controlled by the power amplifier controller integrated in the SC6531. The burst is generated by a 10-bit DAC from SC6531 as shown below:

The ramping shape is referenced with the rising edge of Tx-ON (from the Baseband). There are two types of parameters define the transmit burst: the first one define the shapes of the burst, and the second one define the temporal position of the burst. The rising and the falling edge of the transmit burst are determined by a set of 32 DAC code values $n = 0 \dots 31$.

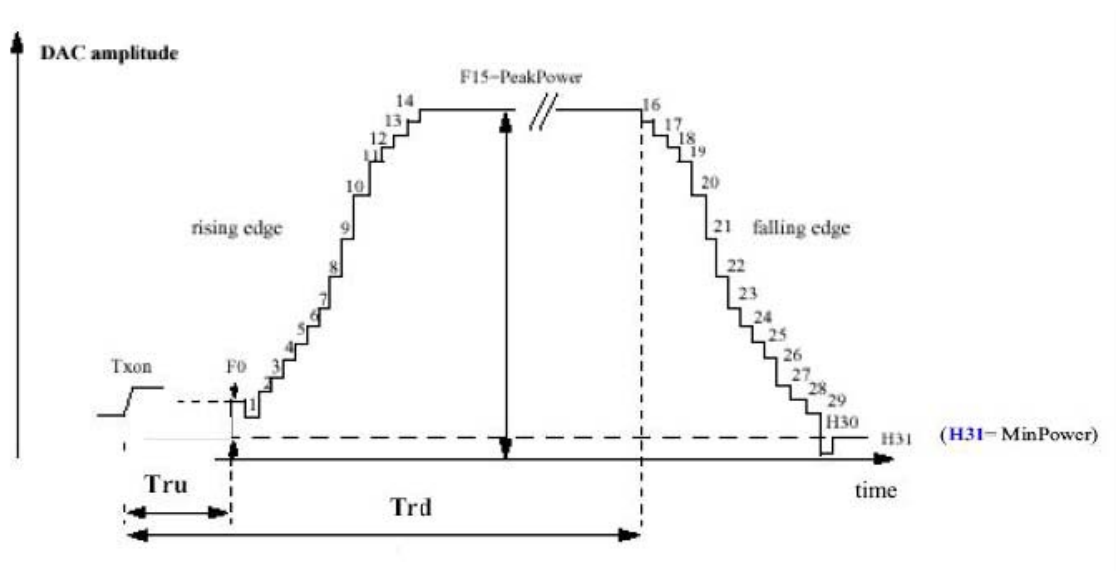

$$\begin{aligned} \text{Tru} &= \text{TxTRU Default} + \triangle \text{TRU_P} + \triangle \text{TRU_T} \\ \text{Trd} &= \text{TxTRD_NBDefault} + \triangle \text{TRD_P (for a normal burst).} \\ \text{Trd} &= \text{TxTRD_ABDefault} + \triangle \text{TRD_P (for an access burst).} \end{aligned}$$

3.Parameters

F (n) are values coming from the DAC to shape the transmit burst. Some F(n) values have a corresponding Parameter used in the TAT to align the mobiles.

Parameter used in TAT = [F (n)].

3.1 Parameters used to shape the burst

- **H0** = [F (1)] controls the rate at which energy is given to the control loop at the beginning of the ramp. This energy is needed to bring the PA system control in a closed loop. This is the second code coming from the SC6531 DAC.

- **PeakPow** = [F (15)] corresponds to the peak power of the transmit burst.

- **H30** = [F (30)] corresponds to the last ramping coefficients used to shape the ramp.
- **MinPow** = [F (31)] is a fixed parameter and corresponds to the Code Start of the RDA6621 specification. It ensures a fast discharge of accumulated energy during the open loop mode in the summing node.

3.2 Parameters used to define the temporal position of the burst

3.2.1 Optimum position of the burst

This parameter is **TRU** (or \triangle **TRU_P**) on the panel, in the Optimal Burst. This is the burst starting time correction, which is optimised for each power control level. (Note that **_P** means that the parameter is a power compensation parameter).

3.2.2 Optimum length of the burst

This parameter is **TRD** (or \triangle **TRD_P**) on the panel, in the Optimal Burst. This is the burst length compensation, which is optimized for each power control level. (Note that **_P** means that the parameter is a power compensation parameter).

4. Operating mode

4.1 How to transmit a Tch burst (Random data), in GSM850 PCS1900 mode, at power control level max:

GSM850/PCS 1900:

Connect the mobile with special software,(meta phone tool)

Select RF Tool .TX level and profile

- set Band: GSM850/PCS1900,

- set ARFCN Channel: 192/661,

- setPCL: 5/0

Press START ,then you can check the burst with CMU200 or

Agilent 8960; it must fit the curve below.

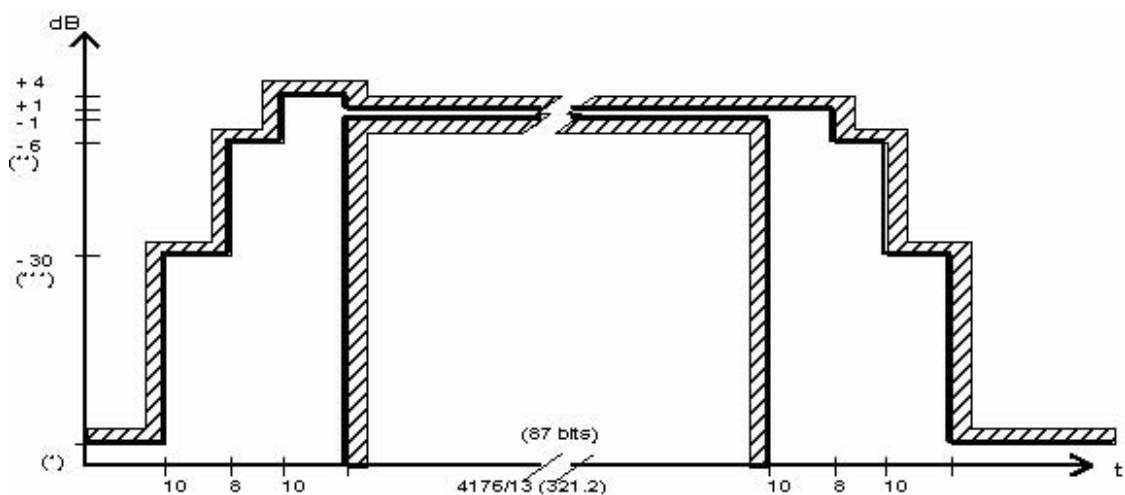

The request of the Power vs. Time.

4.2 How to stop Tx measurements:

Press STOP command to stop the TX.

4.3 How to transmit a burst after modifying parameters

Please note that each time a parameter (such as parameter used to shape the burst) is changed, then the user have to: **download to flash** to validate the parameter modification. If the command is not performed, the old parameters are taken into account.

5. Purpose

This panel gives the description of the Frequency plan. This window includes both:

- Automatic frequency control (AFC),
- Static frequency error and range,
- Dynamic frequency error and range

6. Automatic frequency control

Before a handset is allowed to transmit any signals, it needs to first receive the FSB signal from the base station, demodulate and decode it using its own local oscillator, map it to the constellation plane, calculate the frequency offset, and adjust the local oscillator accordingly, until 0.1ppm of frequency accuracy is achieved. This frequency correction loop is called the automatic frequency control (AFC) loop in GSM standard. The process as below:

Automatic frequency control (AFC)

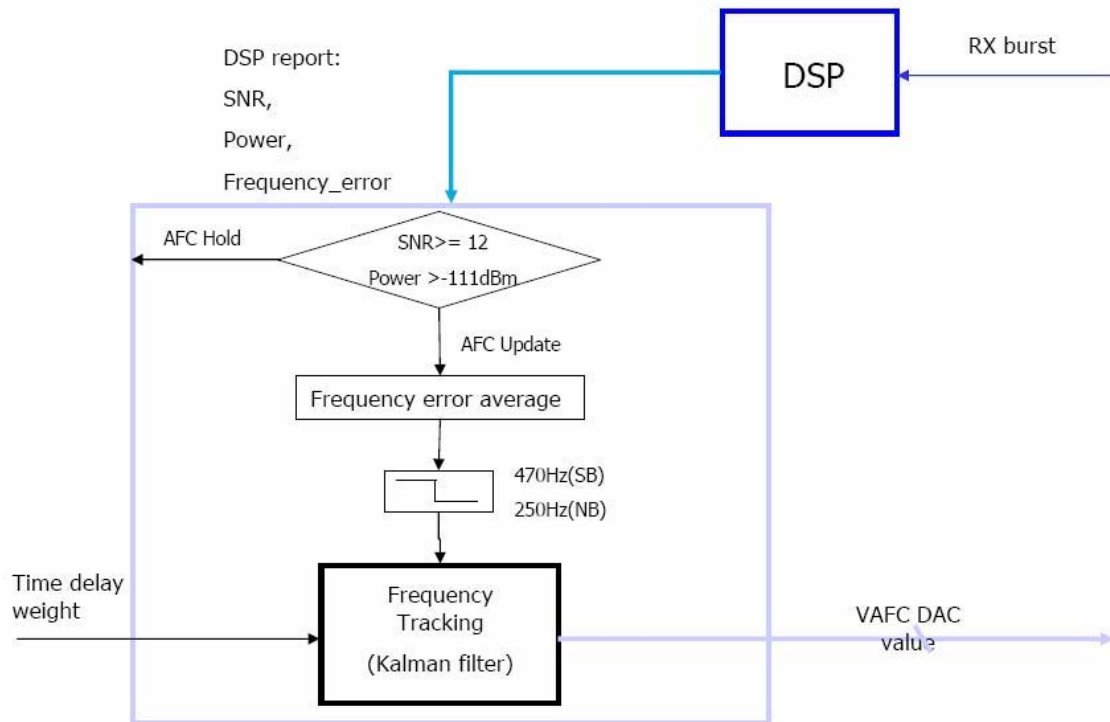

In SC6531, it uses an AFC signal from baseband (DAC) to finish automatic frequency control.

7.Static frequency error and range

- Factors of static frequency error: manufacturing frequency tolerance in crystal at room temperature, aging,
- Static frequency error is compensated for using 7bits programming capacitor array (CAP ID).
- The static frequency range of capacitor array (CAP ID=0 to128) must larger than 34ppm(+-17ppm).
- The static range depends on crystal's TS and CL
- The capacitor array calibration is done in production testing by setting the AFC DAC to mid-scale(4196) and adjusting CAP ID to the setting that give closest to 0 ppm error(finish by test software). This CAP ID value is then stored in Flash memory and rewritten to SC6531 each time the DCXO is initialized.

8. GPRS Data Transfer

GSM mobile phones use a Time Division Multiple Access (TDMA) scheme to transmit data. The TDMA format contains eight time slots. The handset power amplifier typically transmits in four of these up time slots. To prevent interference between cell phones, the time mask profile as specified is very restricted. To meet the GSM time mask, the output power of the PA needs to ramp up and down very quickly while staying within the time mask and not generating extraneous frequency bursts due to

too abrupt ramp profiles. As described before, the Vramp input value sets the RF output power. By applying a certain ramp profile to the Vramp pin, the power level (Pout) of the PA is set to obtain the required time mask. A time mask of the PA's output power is displayed. The time mask meets the limits (displayed by green lines) over a wide range of temperature, voltage and load variations.

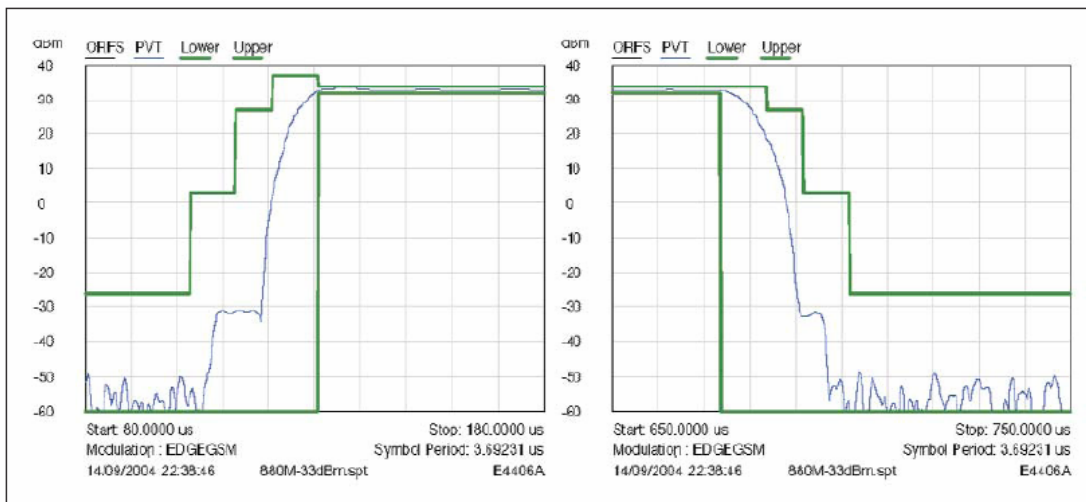

GPRS Output Power

GSM850&PCS1900 allowed maximum output reduction in a multislot Configuration

Number of Timeslots in uplink assignment	Permissible nominal reduction of maximum output Power,(dB)
1	0
2	0 to 3,0
3	1,8 to 4,8
4	3,0 to 6,0

9. Output power

Max Target Power for Production Unit (dBm)			
Mode/Band	Channel		
	Low	Middle	High
GSM 850	32.00	31.50	32.00
GPRS 1 slot	32.00	31.50	32.00
GPRS 2 slot	30.50	31.00	31.00
GPRS 3 slot	29.00	29.00	29.00
GPRS 4 slot	26.50	27.00	27.00
PCS 1900	29.00	29.00	28.50
GPRS 1 slot	29.00	29.00	28.50
GPRS 2 slot	26.50	25.00	24.50
GPRS 3 slot	25.00	25.00	22.50
GPRS 4 slot	23.00	23.00	22.50
Bluetooth	7.00	7.00	7.00