



Test Report No.: PSU-NQN2504020112RF05



Certificate #6613.01

FCC TEST REPORT (PART 90)

Applicant:	InHand Networks, Inc.
Address:	43671 Trade Center Place, Suite 100, Dulles, VA 20166 United States

Manufacturer or Supplier	InHand Networks, Inc.
Address	43671 Trade Center Place, Suite 100, Dulles, VA 20166 United States
Product	Edge Computer
Brand Name	inhand
Model Name	EC3320, EC3310, EC3340
FCC ID	2BPWU-EC3320
Date of tests	Mar. 31, 2025 ~Apr.30, 2025

The tests have been carried out according to the requirements of the following standard:

- FCC Part 90, Subpart R, S ANSI/TIA/EIA-603- D
- FCC Part 2 ANSI/TIA/EIA-603-E ANSI C63.26-2015

CONCLUSION: The submitted sample was found to COMPLY with the test requirement

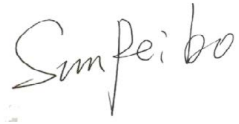
Prepared by Hanwen Xu Engineer / Mobile Department	Approved by Peibo Sun Manager / Mobile Department
	
Date: Apr.30, 2025	Date: Apr.30, 2025

This report is governed by, and incorporates by reference, the Conditions of Testing as posted at the date of issuance of this report at <http://www.bureauveritas.com/home/about-us/our-business/cps/about-us/terms-conditions> and is intended for your exclusive use. Any copying or replication of this report to or for any other person or entity, or use of our name or trademark, is permitted only with our prior written permission. This report sets forth our findings solely with respect to the test samples identified herein. The results set forth in this report are not indicative or representative of the quality or characteristics of the lot from which a test sample was taken or any similar or identical product unless specifically and expressly noted. Our report includes all of the tests requested by you and the results thereof based upon the information that you provided to us. Measurement uncertainty is only provided upon request for accredited tests. Statements of conformity are based on simple acceptance criteria without taking measurement uncertainty into account, unless otherwise requested in writing. You have 60 days from date of issuance of this report to notify us of any material error or omission caused by our negligence or if you require measurement uncertainty; provided, however, that such notice shall be in writing and shall specifically address the issue you wish to raise. A failure to raise such issue within the prescribed time shall constitute your unqualified acceptance of the completeness of this report, the tests conducted and the correctness of the report contents.



TABLE OF CONTENTS

RELEASE CONTROL RECORD 4

1 SUMMARY OF TEST RESULTS 5

1.1 MEASUREMENT UNCERTAINTY 6

1.2 TEST SITE AND INSTRUMENTS 7

2 GENERAL INFORMATION..... 9

2.1 GENERAL DESCRIPTION OF EUT 9

2.2 CONFIGURATION OF SYSTEM UNDER TEST 11

2.3 DESCRIPTION OF SUPPORT UNITS 12

2.4 DESCRIPTION OF TEST MODES 12

2.5 GENERAL DESCRIPTION OF APPLIED STANDARDS 15

3 TEST TYPES AND RESULTS 16

3.1 OUTPUT POWER MEASUREMENT 16

3.1.1 LIMITS OF OUTPUT POWER MEASUREMENT 16

3.1.2 TEST PROCEDURES 16

3.1.3 TEST SETUP 17

3.1.4 TEST RESULTS 17

3.2 RADIATED EMISSION MEASUREMENT 23

3.2.1 LIMITS OF RADIATED EMISSION MEASUREMENT 23

3.2.2 TEST PROCEDURES 23

3.2.3 DEVIATION FROM TEST STANDARD 23

3.2.4 TEST SETUP 24

3.2.5 TEST RESULTS 26

3.3 OCCUPIED BANDWIDTH MEASUREMENT 27

3.3.1 LIMITS OF OCCUPIED BANDWIDTH MEASUREMENT 27

3.3.2 TEST SETUP 27

3.3.3 TEST PROCEDURES 27

3.3.4 TEST RESULTS 27

3.4 FREQUENCY STABILITY MEASUREMENT 28

3.4.1 LIMITS OF FREQUENCY STABILITY MEASUREMENT 28

3.4.2 TEST PROCEDURE 28

3.4.3 TEST SETUP 28

3.4.4 TEST RESULTS 28

3.5 BAND EDGE MEASUREMENT 29

3.5.1 LIMITS OF BAND EDGE MEASUREMENT 29

3.5.2 TEST SETUP 29

3.5.3 TEST PROCEDURES 30

3.5.4 TEST RESULTS 30

3.6 CONDUCTED SPURIOUS EMISSIONS..... 31

3.6.1 LIMITS OF CONDUCTED SPURIOUS EMISSIONS MEASUREMENT 31

3.6.2 TEST PROCEDURE 31

3.6.3 TEST SETUP 31

3.6.4 TEST RESULTS 31

3.7 PEAK TO AVERAGE RATIO 32

3.7.1 LIMITS OF PEAK TO AVERAGE RATIO MEASUREMENT 32

3.7.2 TEST SETUP 32

3.7.3 TEST PROCEDURES 32

3.7.4 TEST RESULTS 32

4 INFORMATION ON THE TESTING LABORATORIES 33



**BUREAU
VERITAS**

Test Report No.: PSU-NQN2504020112RF05

5	MODIFICATIONS RECORDERS FOR ENGINEERING CHANGES TO THE EUT BY THE LAB 34
6	APPENDIX 35



Test Report No.: PSU-NQN2504020112RF05

RELEASE CONTROL RECORD

ISSUE NO.	REASON FOR CHANGE	DATE ISSUED
PSU-NQN2504020112RF05	Original release	Apr.30, 2025



1 SUMMARY OF TEST RESULTS

The EUT has been tested according to the following specifications:

APPLIED STANDARD: FCC Part 90 & Part 2			
STANDARD SECTION	TEST TYPE AND LIMIT	RESULT	TEST LAB*
§2.1046 §90.635(b)	Conducted Output Power (Band26)	PASS	A
§ 90.541(d)	Effective Radiated Power (Band14)	PASS	A
§2.1055 §90.213 §90.539	Frequency Stability	See Note	A
§2.1049 §90.209	Occupied Bandwidth	See Note	A
§2.1051 §90.543(e)(f) §90.691(a)	Emission Masks	See Note	A
§2.1051 §90.543(e)(f) §90.691(a)	Conducted Spurious Emissions	See Note	A
§2.1053 §90.691	Radiated Spurious Emissions	PASS	A

Note: Please Refer to module EM060K-GL and EM120K-GL report.

For module EM060K-GL: Report No.: 2309RSU052-U2, 2309RSU052-U3

FCC ID: XMR2022EM060KGL

For module EM120K-GL: Report No.: 2203RSU046-U3, 2203RSU046-U4

FCC ID: XMR2022EM120KGL

Test Model No.: EC3320

Series Model No.: EC3310, EC3340

These models are the same in these:appearance,PCB layout and basic software function;The only difference is that the products are used in different markets.

*Test Lab Information Reference

Lab A:

Huarui 7Layers High Technology (Suzhou) Co., Ltd.

Lab Address:

Tower N, Innovation Center, 88 Zuyi Road, High-tech District, Suzhou City, Anhui Province

Accredited Test Lab Cert 6613.01

The FCC Site Registration No. is 434559; The Designation No. is CN1325.

1.1 MEASUREMENT UNCERTAINTY

Where relevant, the following measurement uncertainty levels have been estimated for tests performed on the EUT as specified in CISPR 16-4-2:

MEASUREMENT	UNCERTAINTY
Maximum Peak Output Power	±2.06dB
Frequency Stability	±76.97Hz
Radiated emissions (9KHz~30MHz)	±2.68dB
Radiated emissions (30MHz~1GHz)	±4.98dB
Radiated emissions (1GHz ~6GHz)	±4.70dB
Radiated emissions (6GHz ~18GHz)	±4.60dB
Radiated emissions (18GHz ~40GHz)	±4.12dB
Conducted emissions	±4.01dB
Occupied Channel Bandwidth	±43.58KHz
Band Edge Measurements	±4.70dB
Peak to average ratio	±0.76dB

This uncertainty represents an expanded uncertainty expressed at approximately the 95% confidence level using a coverage factor of k=2.

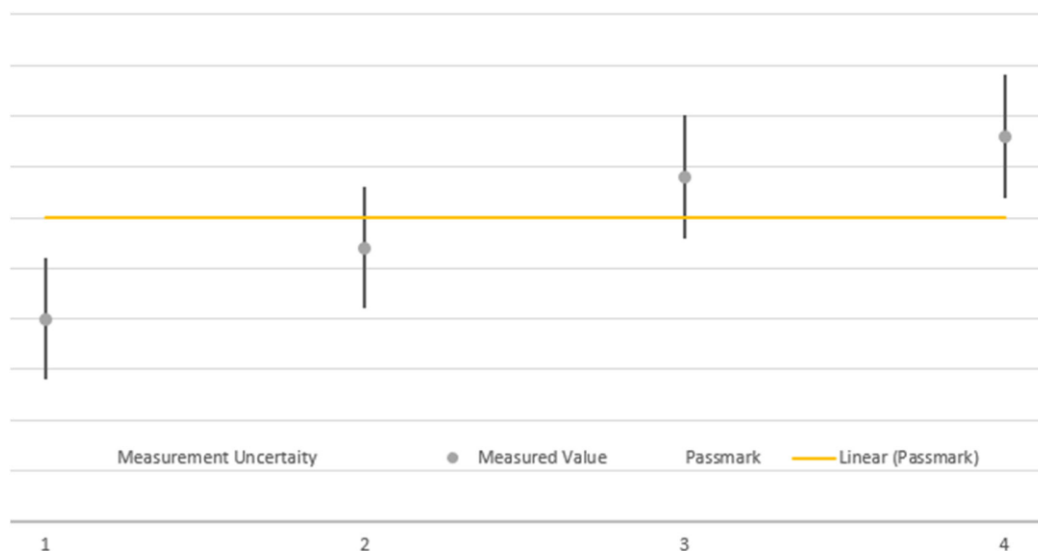

The verdicts in this test report are given according the above diagram:

Case	Measured Value	Uncertainty Range	Verdict
1	below pass mark	below pass mark	Passed
2	below pass mark	within pass mark	Passed
3	above pass mark	within pass mark	Failed
4	above pass mark	above pass mark	Failed

That means, the laboratory applies, as decision rule (see ISO/IEC 17025:2017), the so-called shared risk principle.



1.2 TEST SITE AND INSTRUMENTS

Equipment	Manufacturer	Model No.	Serial No.	Last Cal.	Next Cal.
Pre-Amplifier	R&S	SCU18F1	100815	Aug.30,23	Aug.29,25
Pre-Amplifier	R&S	SCU08F1	101028	Jan.22,24	Jan.21,26
Vector Signal Generator	R&S	SMBV100B	102176	Mar.29,24	Mar.28,26
Signal Generator	R&S	SMB100A	182185	Mar.29,24	Mar.28,26
3m Fully-anechoic Chamber	TDK	9m*6m*6m	HRSW-SZ-EMC-01Chamber	Nov.25,22	Nov.24,25
3m Semi-anechoic Chamber	TDK	9m*6m*6m	HRSW-SZ-EMC-02Chamber	Nov.25,22	Nov.24,25
EMI TEST Receiver	R&S	ESR26	101734	Mar.28,24	Mar.27,26
EMI TEST Receiver	R&S	ESW44	101973	Mar.28,24	Mar.27,26
Bilog Antenna	SCHWARZBECK	VULB 9163	1264	Dec.26,23	Dec.25,25
Horn Antenna	ETS-LINDGREN	3117	227836	Aug.22,23	Aug.21,25
Horn Antenna (18GHz-40GHz)	Steatite Q-par Antennas	QMS 00880	23486	Jul.15,24	Jul.14,26
Horn Antenna	Steatite Q-par Antennas	QMS 00208	23485	Aug.22,23	Aug.21,25
Loop Antenna	SCHWARZ	HFH2-Z2/Z2E	100976	Feb.23,25	Feb.22,27
WIDEBANDRADIO COMMUNICATION TESTER	R&S	CMW500	169399	Jun.19,24	Jun.18,26
Test Software	EMC32	EMC32	N/A	N/A	N/A
6DB attenuator	Tonscend Technology Co., Ltd	N/A	23062787	N/A	N/A
Test Software	ELEKTRA	ELEKTRA4.32	N/A	N/A	N/A
Open Switch and Control Unit	R&S	OSP220	101964	N/A	N/A
DC Source	HYELEC	HY3010B	551016	Aug.31,23	Aug.30,25
Hygrothermograph	DELI	20210528	SZ014	Sep.06,23	Sep.05,25
PC	LENOVO	E14	HRSW0024	N/A	N/A
TMC-AMI18843A(CABLE)	R&S	HF290-NMNM-7.00M	N/A	N/A	N/A
TMC-AMI18843A(CABLE)	R&S	HF290-NMNM-4.00M	N/A	N/A	N/A
CABLE	R&S	W13.02	N/A	Apr.27,25	Apr.26,26
CABLE	R&S	W12.14	N/A	Apr.27,25	Apr.26,26
CABLE	R&S	J12J103539-00-1	SEP-03-20-069	Apr.27,25	Apr.26,26
CABLE	R&S	J12J103539-00-1	SEP-03-20-070	Apr.27,25	Apr.26,26
Temperature Chamber	votsch	VT4002	58566078100050	May.30,24	May.29,26



Test Report No.: PSU-NQN2504020112RF05

- NOTE:**
1. The calibration interval of the above test instruments is 12 / 24/ 36 months and the calibrations are traceable to CEPREI/CHINA, GRGT/CHINA and NIM/CHINA.
 2. The test was performed in 3m Semi-anechoic Chamber and RF Oven Room.
 3. The horn antenna is used only for the measurement of emission frequency above 1GHz if tested.
 4. The FCC Site Registration No. is 434559; The Designation No. is CN1325.



2 GENERAL INFORMATION

2.1 GENERAL DESCRIPTION OF EUT

PRODUCT*	Edge Computer	
BRAND NAME*	inhand	
MODEL NAME*	EC3320, EC3310, EC3340	
NOMINAL VOLTAGE*	12.0Vdc	
MODULATION TECHNOLOGY*	LTE	QPSK
FREQUENCY RANGE	LTE Band 14 Channel Bandwidth: 5MHz	790.5MHz ~ 795.5MHz
	LTE Band 14 Channel Bandwidth: 10MHz	793MHz
	LTE Band 26 (Channel Bandwidth: 1.4MHz)	814.7MHz ~ 823.3MHz
	LTE Band 26 (Channel Bandwidth: 3MHz)	815.5MHz ~ 822.5MHz
	LTE Band 26 (Channel Bandwidth: 5MHz)	816.5MHz ~ 821.5MHz
	LTE Band 26 (Channel Bandwidth: 10MHz)	819MHz
MAX. EIRP POWER	LTE Band 14 Channel Bandwidth: 5MHz	164.06mW
	Sucker Antenna	
ANTENNA TYPE*	1.25 dBi for LTE Band 14/ LTE Band 26	
ANTENNA GAIN*	V2.2	
HW VERSION*	V2.0	
SW VERSION*	Refer to user's manual	
I/O PORTS*	-20°C~60 °C	
EXTREME TEMPERATURE*	9 Vdc~36Vdc	
EXTREME VOLTAGE*		

NOTE1: This product uses the module model EM060K-GL and supports LTE frequency bands 2/4/5/7/12/13/14/17/25/26/30/38/41/42/48/66/71. Therefore, for this product, we referred to the test data reported by the EM060K-GL module and reevaluated the spectrum of radiated emissions and EIRP.

For module EM060K-GL: Report No.: 2309RSU052-U2, 2309RSU052-U3

FCC ID : XMR2022EM060KGL

EM060K-GL and EM120K-GL support the same bands, use the same chips, share the same software and hardware design. The data of EM060K-GL is cited from the data of EM120K-GL.

For module EM120K-GL: Report No.: 2203RSU046-U3, 2203RSU046-U4

FCC ID : XMR2022EM120KGL

NOTE2:

1. *Since the above data and/or information is provided by the client relevant results or conclusions



**BUREAU
VERITAS**

Test Report No.: PSU-NQN2504020112RF05

of this report are only made for these data and/or information, Test Lab is not responsible for the authenticity, integrity and results of the data and information and/or the validity of the conclusion.

2. For a more detailed features description, please refer to the manufacturer's specifications or the user's manual.
3. The EUT incorporates a SISO function. Physically, the EUT provides one completed transmitter and one receiver.

MODULATION MODE	TX FUNCTION
LTE	1TX/1RX

4. For the test results, the EUT had been tested with all conditions. But only the worst case was shown in test report.
5. Antenna gain and EUT conducted cable loss are provided by the customer, and the laboratory will record the results based on these items that involve these two parameters.

2.2 CONFIGURATION OF SYSTEM UNDER TEST

FOR RADIATION EMISSION TEST

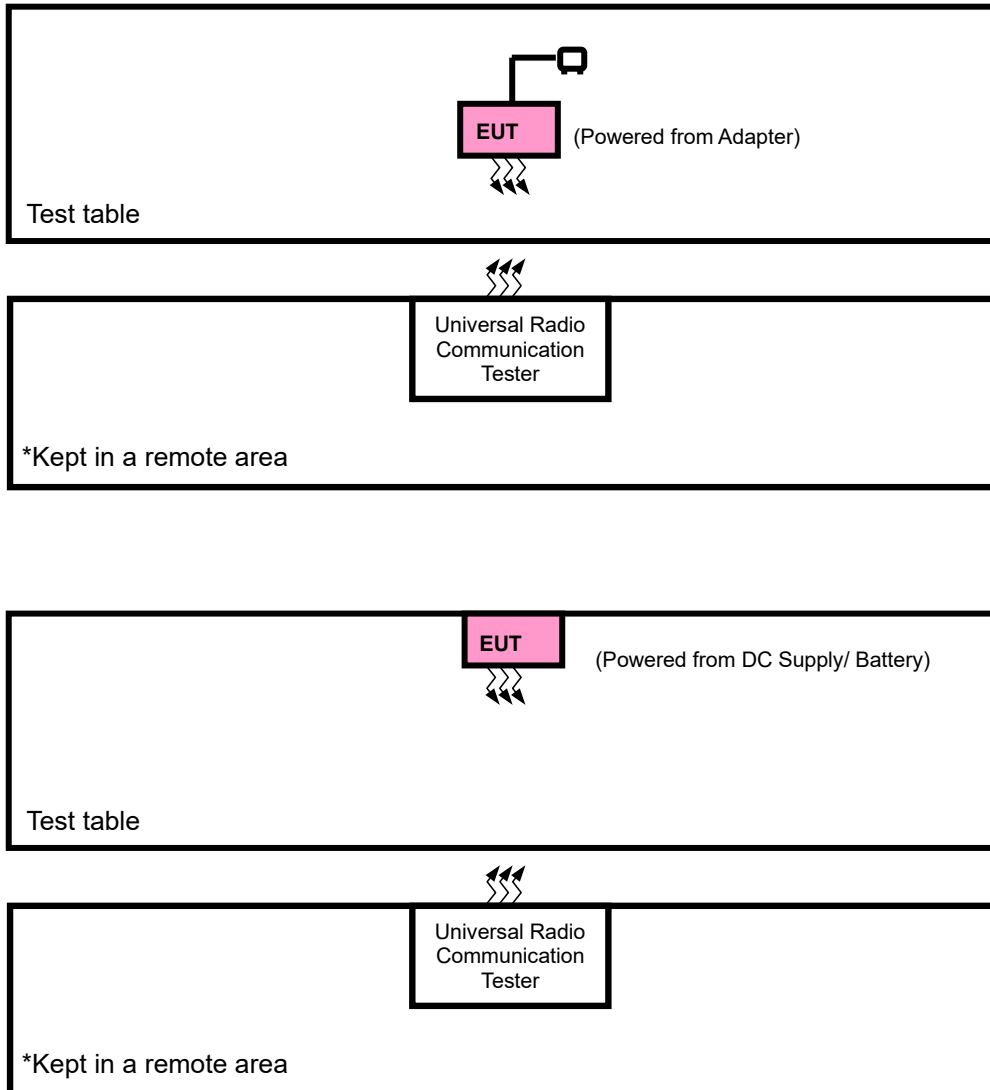



2.3 DESCRIPTION OF SUPPORT UNITS

The EUT has been tested as an independent unit together with other necessary accessories or support units. The following support units or accessories were used to form a representative test configuration during the tests.

NO.	PRODUCT	BRAND	MODEL NO.	SERIAL NO.	FCC ID
1	DC Source	HYELEC	HY3010B	551016	N/A

NO.	SIGNAL CABLE DESCRIPTION OF THE ABOVE SUPPORT UNITS
1	DC Line: Unshielded, Detachable 1.8m

2.4 DESCRIPTION OF TEST MODES

Pre-Scan has been conducted to determine the worst-case mode from all possible combinations between available modulations, data rates, XYZ axis and antenna ports. The worst case in ERP/EIRP and radiated emission was found when positioned on X-plane for LTE. Following channel(s) was (were) selected for the final test as listed below:

EUT CONFIGURE MODE	DESCRIPTION
A	EUT + Adapter + USB Cable with LTE link
B	EUT + DC Supply with LTE link



**BUREAU
VERITAS**

Test Report No.: PSU-NQN2504020112RF05

LTE BAND 14 MODE

EUT CONFIGURE MODE	TEST ITEM	AVAILABLE CHANNEL	TESTED CHANNEL	CHANNEL BANDWIDTH	MODULATION	MODE
A	ERP	23305 to 23355	23305, 23330, 23355	5MHz	QPSK,16QAM,64QAM	1 RB / 0 RB Offset
		23330	23330	10MHz	QPSK,16QAM,64QAM	1 RB / 0 RB Offset
B	FREQUENCY STABILITY	23330	23330	10MHz	QPSK,16QAM,64QAM	50 RB / 0 RB Offset
A	OCCUPIED BANDWIDTH	23305 to 23355	23305, 23330, 23355	5MHz	QPSK,16QAM,64QAM	25 RB / 0 RB Offset
		23330	23330	10MHz	QPSK,16QAM,64QAM	50 RB / 0 RB Offset
A	PEAK TO AVERAGE RATIO	23330	23330	10MHz	QPSK,16QAM,64QAM	1 RB / 0 RB Offset 50 RB / 0 RB Offset
A	BAND EDGE	23305 to 23355	23305	5MHz	QPSK,16QAM, 64QAM	1 RB / 0 RB Offset 25 RB / 0 RB Offset
			23355	5MHz	QPSK,16QAM, 64QAM	1 RB / 24 RB Offset 25 RB / 0 RB Offset
			23300	10MHz	QPSK,16QAM, 64QAM	1 RB / 0 RB Offset 50 RB / 0 RB Offset 1 RB / 49 RB Offset
		23330	23330	10MHz	QPSK,16QAM, 64QAM	1 RB / 0 RB Offset 50 RB / 0 RB Offset 1 RB / 49 RB Offset
			23330	10MHz	QPSK,16QAM, 64QAM	1 RB / 0 RB Offset 50 RB / 0 RB Offset 1 RB / 49 RB Offset
			23330	10MHz	QPSK,16QAM, 64QAM	1 RB / 0 RB Offset 50 RB / 0 RB Offset 1 RB / 49 RB Offset
A	CONDUCTED EMISSION	23305 to 23355	23305, 23330, 23355	5MHz	QPSK,16QAM,64QAM	1 RB / 0 RB Offset
		23330	23330	10MHz	QPSK,16QAM,64QAM	1 RB / 0 RB Offset
A	RADIATED EMISSION	23305 to 23355	23305, 23330, 23355	5MHz	QPSK	1 RB / 0 RB Offset
		23330	23330	10MHz	QPSK	1 RB / 0 RB Offset

Note: This device was tested under all bandwidths, RB configurations and modulations. The worst case was found in QPSK modulation.

LTE BAND 26 MODE

EUT CONFIGURE MODE	TEST ITEM	AVAILABLE CHANNEL	TESTED CHANNEL	CHANNEL BANDWIDTH	MODULATION	MODE		
A	ERP	26697 to 26783	26697, 26740, 26783	1.4MHz	QPSK, 16QAM, 64QAM	1 RB / 0 RB Offset		
		26705 to 26775	26705, 26740, 26775	3MHz	QPSK, 16QAM, 64QAM	1 RB / 0 RB Offset		
		26715 to 26765	26715, 26740, 26765	5MHz	QPSK, 16QAM, 64QAM	1 RB / 0 RB Offset		
		26740	26740	10MHz	QPSK, 16QAM, 64QAM	1 RB / 0 RB Offset		
B	FREQUENCY STABILITY	26740	26740	10MHz	QPSK, 16QAM, 64QAM	50 RB / 0 RB Offset		
A	OCCUPIED BANDWIDTH	26697 to 26783	26697, 26740, 26783	1.4MHz	QPSK, 16QAM, 64QAM	6 RB / 0 RB Offset		
		26705 to 26775	26705, 26740, 26775	3MHz	QPSK, 16QAM, 64QAM	15 RB / 0 RB Offset		
		26715 to 26765	26715, 26740, 26765	5MHz	QPSK, 16QAM, 64QAM	25 RB / 0 RB Offset		
		26740	26740	10MHz	QPSK, 16QAM, 64QAM	50 RB / 0 RB Offset		
A	PEAK TO AVERAGE RATIO	26740	26740	10MHz	QPSK, 16QAM, 64QAM	1 RB / 0 RB Offset 50 RB / 0 RB Offset		
A	BAND EDGE	26697 to 26783	26697	1.4MHz	QPSK, 16QAM, 64QAM	1 RB / 0 RB Offset 6 RB / 0 RB Offset		
			26783	1.4MHz	QPSK, 16QAM, 64QAM	1 RB / 5 RB Offset 6 RB / 0 RB Offset		
			26705 to 26775	26705	3MHz	QPSK, 16QAM, 64QAM	1 RB / 0 RB Offset 15 RB / 0 RB Offset	
				26775	3MHz	QPSK, 16QAM, 64QAM	1 RB / 14 RB Offset 15 RB / 0 RB Offset	
		26715 to 26765	26715	5MHz	QPSK, 16QAM, 64QAM	1 RB / 0 RB Offset 25 RB / 0 RB Offset		
				26765	5MHz	QPSK, 16QAM, 64QAM	1 RB / 24 RB Offset 25 RB / 0 RB Offset	
			26740	26740	10MHz	QPSK, 16QAM, 64QAM	1 RB / 0 RB Offset 50 RB / 0 RB Offset	
				26740	10MHz	QPSK, 16QAM, 64QAM	1 RB / 49 RB Offset 50 RB / 0 RB Offset	
		A	CONDUCTED EMISSION	26697 to 26783	26697, 26740, 26783	1.4MHz	QPSK, 16QAM, 64QAM	1 RB / 0 RB Offset
				26705 to 26775	26705, 26740, 26775	3MHz	QPSK, 16QAM, 64QAM	1 RB / 0 RB Offset
				26715 to 26765	26715, 26740, 26765	5MHz	QPSK, 16QAM, 64QAM	1 RB / 0 RB Offset
				26740	26740	10MHz	QPSK, 16QAM, 64QAM	1 RB / 0 RB Offset
A	RADIATED EMISSION	26697 to 26783	26740	1.4MHz	QPSK	1 RB / 0 RB Offset		
		26705 to 26775	26705, 26740, 26775	3MHz	QPSK	1 RB / 0 RB Offset		
		26715 to 26765	26740	5MHz	QPSK	1 RB / 0 RB Offset		
		26740	26740	10MHz	QPSK	1 RB / 0 RB Offset		

Note: This device was tested under all bandwidths, RB configurations and modulations. The worst case was found in QPSK modulation.



Test Report No.: PSU-NQN2504020112RF05

TEST CONDITION:

TEST ITEM	ENVIRONMENTAL CONDITIONS	INPUT POWER	TESTED BY
EIRP(ERP)	24deg. C, 60%RH	DC 12V By Adapter	Hanwen Xu
FREQUENCY STABILITY	24deg. C, 61%RH	DC 12V By Adapter	Hanwen Xu
OCCUPIED BANDWIDTH	24deg. C, 61%RH	DC 12V By Adapter	Hanwen Xu
BAND EDGE	24deg. C, 61%RH	DC 12V By Adapter	Hanwen Xu
CONDUCTED EMISSION	24deg. C, 61%RH	DC 12V By Adapter	Hanwen Xu
RADIATED EMISSION	23deg. C, 70%RH	DC 12V By Adapter	Hanwen Xu

2.5 GENERAL DESCRIPTION OF APPLIED STANDARDS

The EUT is a RF product. According to the specifications of the manufacturer, it must comply with the requirements of the following standards:

FCC 47 CFR Part 2

FCC 47 CFR Part 90

ANSI/TIA/EIA-603-D

ANSI/TIA/EIA-603-E

ANSI C63.26-2015

NOTE: All test items have been performed and recorded as per the above standards.



3 TEST TYPES AND RESULTS

3.1 OUTPUT POWER MEASUREMENT

3.1.1 LIMITS OF OUTPUT POWER MEASUREMENT

47 CFR 90.542(a)(6)

Control stations and mobile stations transmitting in the 758–768 MHz band and the 788–798 MHz band are limited to 30 watts ERP.

47 CFR 90.542(a)(7)

Portable stations (hand-held devices) transmitting in the 758–768 MHz band and the 788–798 MHz band are limited to 3 watts ERP.

Per FCC Part 90.635(a)(b)

The maximum output power of the transmitter for mobile stations is 100 watts (20 dBw).

3.1.2 TEST PROCEDURES

EIRP / ERP MEASUREMENT:

Per KDB 971168 D01 Power Meas License Digital Systems v03r01 or subclause 5.2.5.5 of ANSI C63.26-2015, the relevant equation for determining the ERP or EIRP from the conducted RF output power measured using the guidance provided above is:

$$\text{ERP or EIRP} = P_{\text{Meas}} + G_{\text{T}} - L_{\text{C}}$$

Where:

ERP or EIRP = effective radiated power or equivalent isotropically radiated power, respectively

(expressed in the same units as P_{Meas} , typically dBW or dBm);

P_{Meas} = measured transmitter output power or PSD, in dBm or dBW;

G_{T} = gain of the transmitting antenna, in dBd (ERP) or dBi (EIRP);

L_{C} = signal attenuation in the connecting cable between the transmitter and antenna, in dB

CONDUCTED POWER MEASUREMENT:

- a. The EUT was set up for the maximum power with LTE link data modulation and link up with simulator.
- b. Set the EUT to transmit under low, middle and high channel and record the power level shown on simulator.

3.1.3 TEST SETUP

CONDUCTED POWER MEASUREMENT:

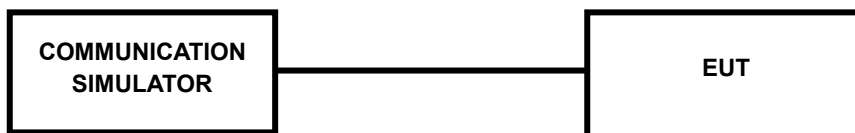

For the actual test configuration, please refer to the attached file (Test Setup Photo).

3.1.4 TEST RESULTS

LTE Band 14

Frequency (MHz)	Channel Bandwidth (MHz)	RB Size	RB Offset	Output Power (dBm)	ERP (dBm)	Limit (dBm)
QPSK						
790.5	5	1	0	23.03	22.13	<34.77
793				23.04	22.14	<34.77
795.5				22.99	22.09	<34.77
790.5	5	1	12	22.97	22.07	<34.77
793				23.05	22.15	<34.77
795.5				22.95	22.05	<34.77
790.5	5	1	24	22.91	22.01	<34.77
793				22.98	22.08	<34.77
795.5				22.96	22.06	<34.77
790.5	5	25	0	22.06	21.16	<34.77
793				22.05	21.15	<34.77
795.5				22.1	21.2	<34.77
793	10	1	0	23.03	22.13	<34.77
793			24	23	22.1	<34.77
793			49	22.96	22.06	<34.77
793	10	50	0	22.12	21.22	<34.77

Note: The ERP (dBm) = Output Power (dBm) + Antenna Gain (dBi) - 2.15

Frequency (MHz)	Channel Bandwidth (MHz)	RB Size	RB Offset	Output Power (dBm)	ERP (dBm)	Limit (dBm)
16QAM						
790.5	5	1	0	22.4	21.5	< 44.77
793				22.3	21.4	< 44.77



**BUREAU
VERITAS**

Test Report No.: PSU-NQN2504020112RF05

795.5				22.5	21.6	< 44.77
790.5	5	1	12	22.28	21.38	< 44.77
793				22.36	21.46	< 44.77
795.5				22.24	21.34	< 44.77
790.5	5	1	24	22.3	21.4	< 44.77
793				22.34	21.44	< 44.77
795.5				22.29	21.39	< 44.77
790.5	5	25	0	21.07	20.17	< 44.77
793				21.04	20.14	< 44.77
795.5				21.07	20.17	< 44.77
793	10	1	0	22.41	21.51	< 44.77
793			24	22.18	21.28	< 44.77
793			49	22.07	21.17	< 44.77
793	10	50	0	21.1	20.2	< 44.77
64QAM						
790.5	5	1	0	21.3	20.4	< 44.77
793				21.29	20.39	< 44.77
795.5				21.27	20.37	< 44.77
790.5	5	1	12	21.3	20.4	< 44.77
793				21.16	20.26	< 44.77
795.5				21.26	20.36	< 44.77
790.5	5	1	24	21.16	20.26	< 44.77
793				21.17	20.27	< 44.77
795.5				21.15	20.25	< 44.77
790.5	5	25	0	20.11	19.21	< 44.77
793				20.06	19.16	< 44.77
795.5				20.06	19.16	< 44.77
793	10	1	0	21.31	20.41	< 44.77
793			24	21.23	20.33	< 44.77
793			49	21.22	20.32	< 44.77
793	10	50	0	20.09	19.19	< 44.77
Note: The ERP (dBm) = Output Power (dBm) + Antenna Gain (dBi) - 2.15						



**BUREAU
VERITAS**

Test Report No.: PSU-NQN2504020112RF05

LTE Band 26

Frequency (MHz)	Channel Bandwidth (MHz)	RB Size	RB Offset	Output Power (dBm)	ERP (dBm)	Limit (dBm)
QPSK						
814.7	1.4	1	0	23.01	22.11	< 50
819				22.98	22.08	< 50
823.3				22.89	21.99	< 50
814.7	1.4	1	2	23.09	22.19	< 50
819				22.98	22.08	< 50
823.3				23.01	22.11	< 50
814.7	1.4	1	6	22.95	22.05	< 50
819				22.91	22.01	< 50
823.3				22.98	22.08	< 50
814.7	1.4	6	0	22.13	21.23	< 50
819				22.07	21.17	< 50
823.3				22.03	21.13	< 50
815.5	3	1	0	23.06	22.16	< 50
819				23.05	22.15	< 50
822.5				23.02	22.12	< 50
815.5	3	1	7	23.15	22.25	< 50
819				23.09	22.19	< 50
822.5				23.07	22.17	< 50
815.5	3	1	14	22.98	22.08	< 50
819				22.99	22.09	< 50
822.5				23.01	22.11	< 50
815.5	3	15	0	22.25	21.35	< 50
819				22.16	21.26	< 50
822.5				22.22	21.32	< 50
816.5	5	1	0	23.08	22.18	< 50
819				23.05	22.15	< 50
821.5				23	22.1	< 50
816.5	5	1	12	23.02	22.12	< 50
819				23.07	22.17	< 50
821.5				22.98	22.08	< 50
816.5	5	1	24	23.06	22.16	< 50
819				23	22.1	< 50
821.5				23.1	22.2	< 50
816.5	5	25	0	22.19	21.29	< 50
819				22.16	21.26	< 50
821.5				22.22	21.32	< 50
819	10	1	0	23.07	22.17	< 50
		1	24	23.04	22.14	< 50
		1	49	23.03	22.13	< 50



**BUREAU
VERITAS**

Test Report No.: PSU-NQN2504020112RF05

		50	0	22.22	21.32	< 50
821.5	15	1	0	23.17	22.27	< 50
		1	36	23.02	22.12	< 50
		1	74	22.99	22.09	< 50
		75	0	22.22	21.32	< 50

Note: The ERP (dBm) = Output Power (dBm) + Antenna Gain (dBi) - 2.15

Frequency (MHz)	Channel Bandwidth (MHz)	RB Size	RB Offset	Output Power (dBm)	ERP (dBm)	Limit (dBm)
16QAM						
814.7	1.4	1	0	22.18	21.28	< 50
819				22.06	21.16	< 50
823.3				22.21	21.31	< 50
814.7	1.4	1	2	22.27	21.37	< 50
819				22.11	21.21	< 50
823.3				22.1	21.2	< 50
814.7	1.4	1	6	22.12	21.22	< 50
819				22.09	21.19	< 50
823.3				22.13	21.23	< 50
814.7	1.4	6	0	21.09	20.19	< 50
819				21.03	20.13	< 50
823.3				21.04	20.14	< 50
815.5	3	1	0	22.35	21.45	< 50
819				22.3	21.4	< 50
822.5				22.3	21.4	< 50
815.5	3	1	7	22.49	21.59	< 50
819				22.35	21.45	< 50
822.5				22.42	21.52	< 50
815.5	3	1	14	22.31	21.41	< 50
819				22.26	21.36	< 50
822.5				22.44	21.54	< 50
815.5	3	15	0	21.19	20.29	< 50
819				21.11	20.21	< 50
822.5				21.25	20.35	< 50
816.5	5	1	0	22.46	21.56	< 50
819				22.17	21.27	< 50
821.5				22.3	21.4	< 50
816.5	5	1	12	22.39	21.49	< 50
819				22.19	21.29	< 50
821.5				22.4	21.5	< 50
816.5				22.24	21.34	< 50



**BUREAU
VERITAS**

Test Report No.: PSU-NQN2504020112RF05

819	5	1	24	22.23	21.33	< 50
821.5				22.36	21.46	< 50
816.5	5	25	0	21.1	20.2	< 50
819				21.07	20.17	< 50
821.5				21.25	20.35	< 50
819	10	1	0	22.25	21.35	< 50
		1	24	22.2	21.3	< 50
		1	49	22.21	21.31	< 50
		50	0	21.21	20.31	< 50
821.5	15	1	0	22.36	21.46	< 50
		1	36	22.27	21.37	< 50
		1	74	22.41	21.51	< 50
		75	0	21.25	20.35	< 50
64QAM						
814.7	1.4	1	0	21.23	20.33	< 50
819				21.21	20.31	< 50
823.3				21.11	20.21	< 50
814.7	1.4	1	2	21.29	20.39	< 50
819				21.27	20.37	< 50
823.3				21.38	20.48	< 50
814.7	1.4	1	6	21.23	20.33	< 50
819				21.26	20.36	< 50
823.3				21.1	20.2	< 50
814.7	1.4	6	0	20.09	19.19	< 50
819				20.18	19.28	< 50
823.3				20.05	19.15	< 50
815.5	3	1	0	21.25	20.35	< 50
819				21.22	20.32	< 50
822.5				21.21	20.31	< 50
815.5	3	1	7	21.35	20.45	< 50
819				21.27	20.37	< 50
822.5				21.35	20.45	< 50
815.5	3	1	14	21.29	20.39	< 50
819				21.26	20.36	< 50
822.5				21.27	20.37	< 50
815.5	3	15	0	20.14	19.24	< 50
819				20.14	19.24	< 50
822.5				20.22	19.32	< 50
816.5	5	1	0	21.38	20.48	< 50
819				21.25	20.35	< 50
821.5				21.32	20.42	< 50
816.5	5	1	12	21.37	20.47	< 50
819				21.3	20.4	< 50



**BUREAU
VERITAS**

Test Report No.: PSU-NQN2504020112RF05

821.5				21.24	20.34	< 50
816.5	5	1	24	21.15	20.25	< 50
819				21.17	20.27	< 50
821.5				21.27	20.37	< 50
816.5	5	25	0	20.15	19.25	< 50
819				20.09	19.19	< 50
821.5				20.23	19.33	< 50
819	10	1	0	21.37	20.47	< 50
		1	24	21.27	20.37	< 50
		1	49	21.36	20.46	< 50
		50	0	20.22	19.32	< 50
821.5	15	1	0	21.49	20.59	< 50
		1	36	21.19	20.29	< 50
		1	74	21.36	20.46	< 50
		75	0	20.24	19.34	< 50

3.2 RADIATED EMISSION MEASUREMENT

3.2.1 LIMITS OF RADIATED EMISSION MEASUREMENT

(1) The power of any emission outside a licensee's frequency block shall be attenuated below the transmitter power (P) by at least $43 + 10 \log_{10}(P)$ dB. The limit of emission equal to -13 dBm

(2) For operations in the 763–775 MHz and 793–805 MHz bands, all emissions including harmonics in the band 1559–1610 MHz shall be limited to -70 dBW/MHz equivalent isotropically radiated power (EIRP) for wideband signals, and -80 dBW EIRP for discrete emissions of less than 700 Hz bandwidth. For the purpose of equipment authorization, a transmitter shall be tested with an antenna that is representative of the type that will be used with the equipment in normal operation.

3.2.2 TEST PROCEDURES

- a. Substitution method is used for E.I.R.P measurement. In the semi-anechoic chamber, EUT placed on the 0.8m height of Turn Table, rotated the table around 360 degrees to search the maximum radiation power and receiver antenna shall be rotated vertical and horizontal polarization and moved height from 1m to 4m to find the maximum polar radiated power. The “Read Value” is the spectrum reading the maximum power value.
- b. The substitution horn antenna is substituted for EUT at the same position and signals generator export the CW signal to the substitution antenna via a TX cable. Rotated the Turn Table and moved receiving antenna to find the maximum radiation power. Adjust output power level of S.G to get a Value of spectrum reading equal to “Read Value” of step a. Record the power level of S.G
- c. $EIRP = \text{Output power level of S.G} - \text{TX cable loss} + \text{Antenna gain of substitution horn}$.
- d. E.R.P power can be calculated form E.I.R.P power by subtracting the gain of dipole, $E.R.P \text{ power} = E.I.P.R \text{ power} - 2.15\text{dBi}$.

NOTE: The resolution bandwidth of spectrum analyzer is 1 MHz and the video bandwidth is 3 MHz.

3.2.3 DEVIATION FROM TEST STANDARD

No deviation

3.2.4 TEST SETUP

<Below 30MHz>

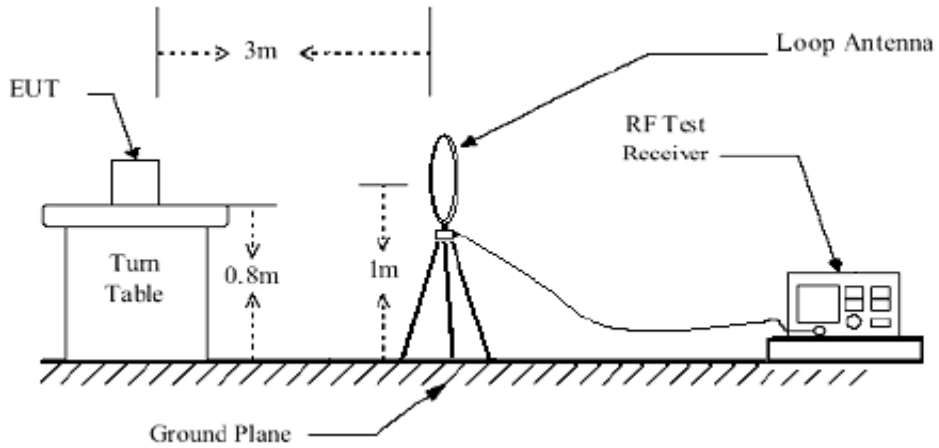

< Frequency Range 30MHz~1GHz >

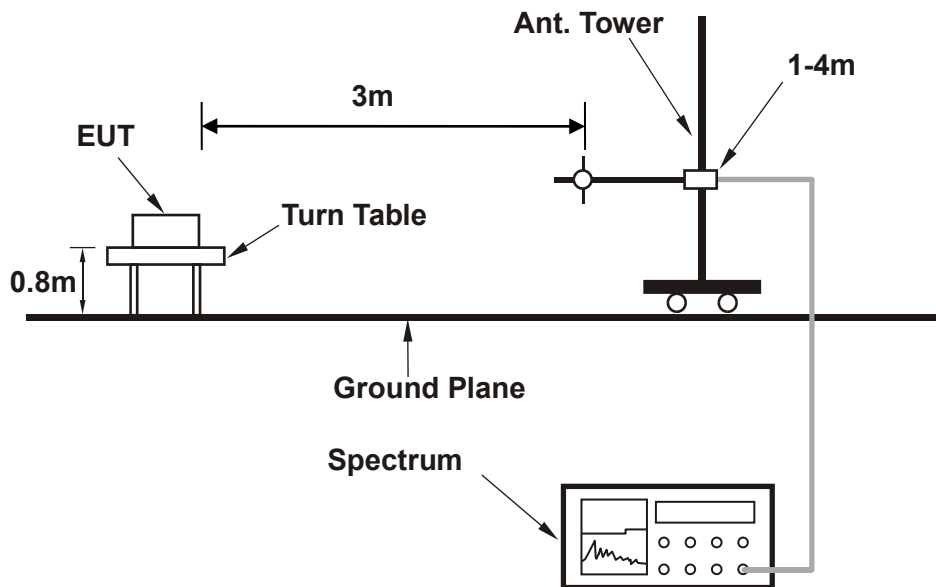

< Frequency Range above 1GHz >

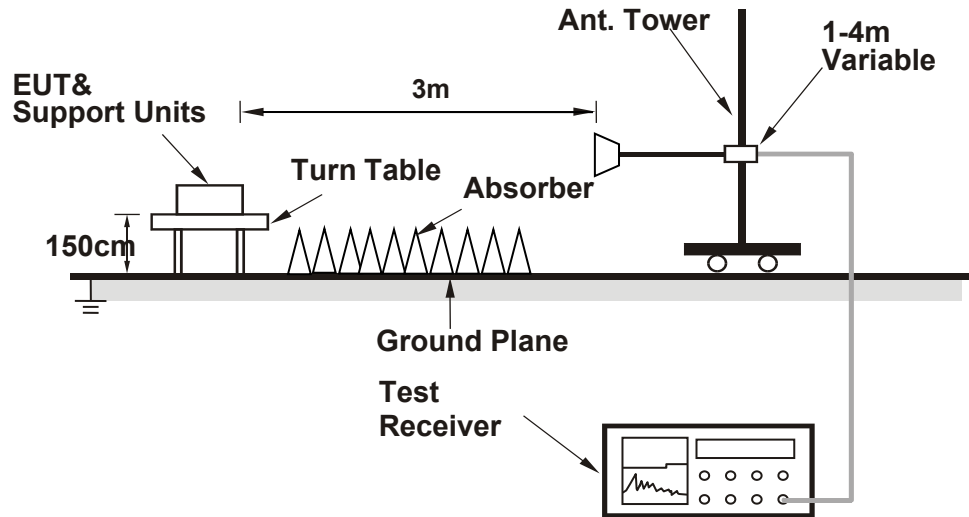

For the actual test configuration, please refer to the attached file (Test Setup Photo).



3.2.5 TEST RESULTS

NOTE1: The 9K~30MHz amplitude of spurious emissions attenuated more than 20 dB below the permissible value is not required in the report.

NOTE2: The measurement range is 30M to the tenth harmonic of the highest fundamental frequency, For the test results, the EUT had been tested with all conditions. But only the worst case was shown in test report.

LTE-B14

Frequency (MHz)	Power (dBm)	Limited (dBm)	Polarization
1147.00	-80.94	-13	PV
1518.00	-77.45	-13	PV
2425.38	-74.03	-13	PV
3114.00	-82.94	-13	PV
3555.00	-81.16	-13	PV
4509.00	-88.90	-13	PV

LTE-B26

Frequency (MHz)	Power (dBm)	Limited (dBm)	Polarization
1154.00	-80.87	-13	PV
1532.00	-77.85	-13	PV
2441.00	-67.15	-13	PV
3099.00	-82.86	-13	PV
3507.00	-81.10	-13	PV
4299.00	-89.14	-13	PV

3.3 OCCUPIED BANDWIDTH MEASUREMENT

3.3.1 LIMITS OF OCCUPIED BANDWIDTH MEASUREMENT

The width of a frequency band such that, below the lower and above the upper frequency limits, the mean powers emitted are each equal to a specified percentage 0.5 %of the total mean power of a given emission.

3.3.2 TEST SETUP

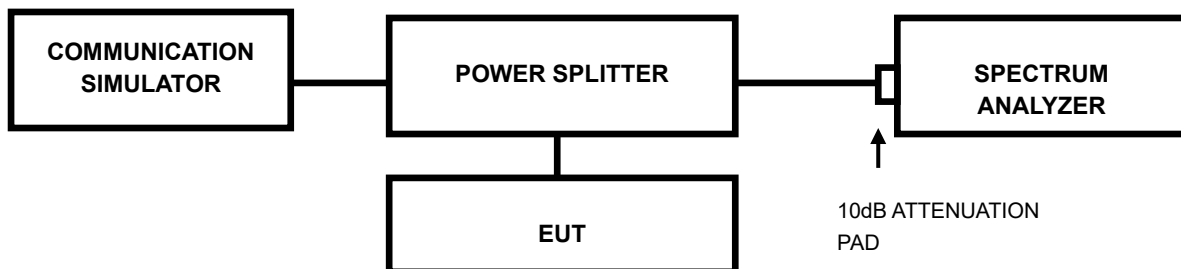

3.3.3 TEST PROCEDURES

- The conducted occupied bandwidth used the power splitter via EUT RF power connector between simulation base station and spectrum analyzer.
- Use OBW measurement function of Spectrum analyzer to measure 99 % occupied bandwidth.

3.3.4 TEST RESULTS

Please Refer to module EM060K-GL and EM120K-GL report.

For module EM060K-GL: Report No.: 2309RSU052-U2, 2309RSU052-U3

FCC ID : XMR2022EM060KGL

For module EM120K-GL: Report No.: 2203RSU046-U3, 2203RSU046-U4

FCC ID : XMR2022EM120KGL

3.4 FREQUENCY STABILITY MEASUREMENT

3.4.1 LIMITS OF FREQUENCY STABILITY MEASUREMENT

1.5 ppm is for base and fixed station. 2.5 ppm is for mobile station.

3.4.2 TEST PROCEDURE

- a. Device is placed at the oven room. The oven room could control the temperatures and humidity. Power warm up is at least 15 min and power applied should perform before recording frequency error.
- b. EUT is connected the external power supply to control the DC input power. The test voltage range is from minimum to maximum working voltage. Each step shall be record the frequency error rate.
- c. The temperature range step is 10 degrees in this test items. All temperature levels shall be hold the $\pm 0.5^{\circ}\text{C}$ during the measurement testing. The each temperature step shall be at least 0.5 hours, consider the EUT could be test under the stability condition.

NOTE: The frequency error was recorded frequency error from the communication simulator.

3.4.3 TEST SETUP

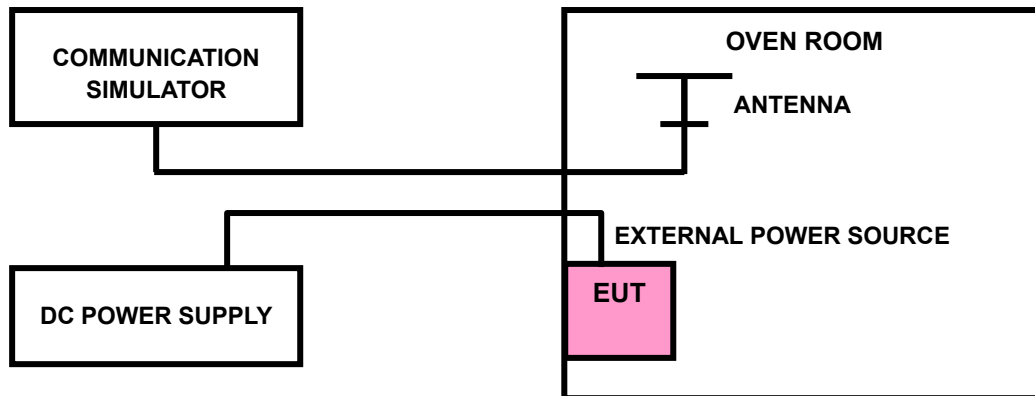

3.4.4 TEST RESULTS

Please Refer to module EM060K-GL and EM120K-GL report.

For module EM060K-GL: Report No.: 2309RSU052-U2, 2309RSU052-U3

FCC ID : XMR2022EM060KGL

For module EM120K-GL: Report No.: 2203RSU046-U3, 2203RSU046-U4

FCC ID : XMR2022EM120KGL

3.5 BAND EDGE MEASUREMENT

3.5.1 LIMITS OF BAND EDGE MEASUREMENT

Power of any emission outside of the authorized operating frequency ranges must be attenuated below the transmitting power (P) by a factor of at least $43 + 10 \log(P)$ dB. In the 1 MHz bands immediately outside and adjacent to the frequency block a resolution bandwidth of at least one percent of the emission bandwidth of the fundamental emission of the transmitter may be employed.

3.5.2 TEST SETUP

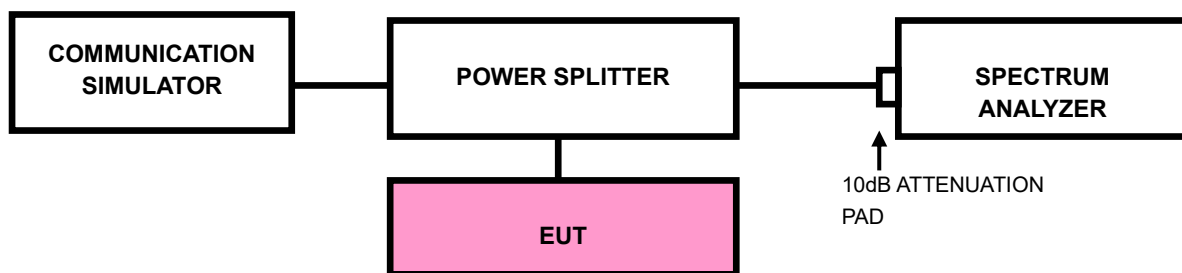



3.5.3 TEST PROCEDURES

- a) All measurements were done at low and high operational frequency range
- b) Connect the transmitter to the spectrum analyzer via coaxial cable while ensuring proper impedance matching.
- c) Tune the analyzer to the nominal center frequency of the emission bandwidth
(EBW)
- d) .Set the resolution bandwidth (RBW) $\geq 1\%$ EBW in the 1MHz band immediately outside and adjacent to the band edge.
- e) Beyond the 1MHz band from the band edge, RBW=1MHz was used.
- f) Set the video bandwidth (VBW) to $\geq 3 \times$ RBW.
- g) Select the average power (RMS) display detector.
- h) Set the number of measurement points to ≥ 1001 .
- i) Use auto-coupled sweep time.
- j) Perform the measurement over an interval of time when the transmission is continuous and at its maximum power level.
- k) The RF fundamental frequency should be excluded against the limit line in the operating frequency band and use RBW is 10KHz or 100KHz.
- l) Record the max trace plot into the test report.

3.5.4 TEST RESULTS

Please Refer to module EM060K-GL and EM120K-GL report.

For module EM060K-GL: Report No.: 2309RSU052-U2, 2309RSU052-U3

FCC ID : XMR2022EM060KGL

For module EM120K-GL: Report No.: 2203RSU046-U3, 2203RSU046-U4

FCC ID : XMR2022EM120KGL

3.6 CONDUCTED SPURIOUS EMISSIONS

3.6.1 LIMITS OF CONDUCTED SPURIOUS EMISSIONS MEASUREMENT

The power of any emission outside of the authorized operating frequency ranges must be attenuated below the transmitting power (P) by a factor of at least $43 + 10 \log(P)$ dB. The emission limit equal to -13dBm .

3.6.2 TEST PROCEDURE

- a. The EUT makes a phone call to the communication simulator. All measurements were done at low, middle and high operational frequency range.
- b. Measuring frequency range is from 9kHz up to a frequency including its 10th harmonic. 10dB attenuation pad is connected with spectrum. RBW=1MHz and VBW=3MHz is used for conducted emission measurement.

3.6.3 TEST SETUP

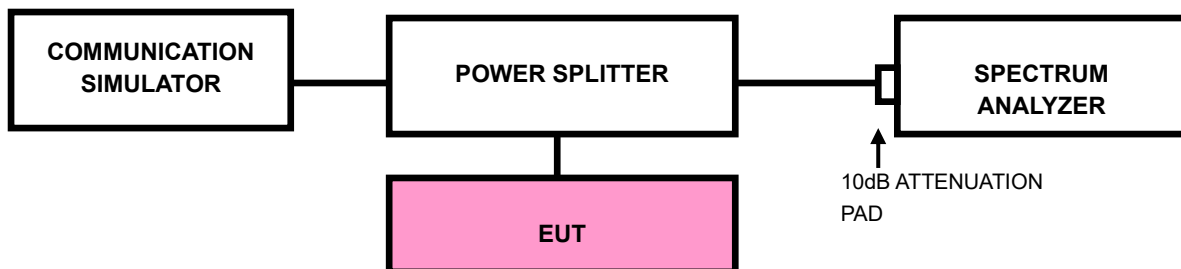

3.6.4 TEST RESULTS

NOTE : The 9K~30MHz amplitude of spurious emissions attenuated more than 20 dB below the permissible value is not required in the report.

Please Refer to module EM060K-GL and EM120K-GL report.

For module EM060K-GL: Report No.: 2309RSU052-U2, 2309RSU052-U3

FCC ID : XMR2022EM060KGL

For module EM120K-GL: Report No.: 2203RSU046-U3, 2203RSU046-U4

FCC ID : XMR2022EM120KGL

3.7 PEAK TO AVERAGE RATIO

3.7.1 LIMITS OF PEAK TO AVERAGE RATIO MEASUREMENT

In measuring transmissions in this band using an average power technique, the peak to-average ratio (PAR) of the transmission may not exceed 13 dB

3.7.2 TEST SETUP

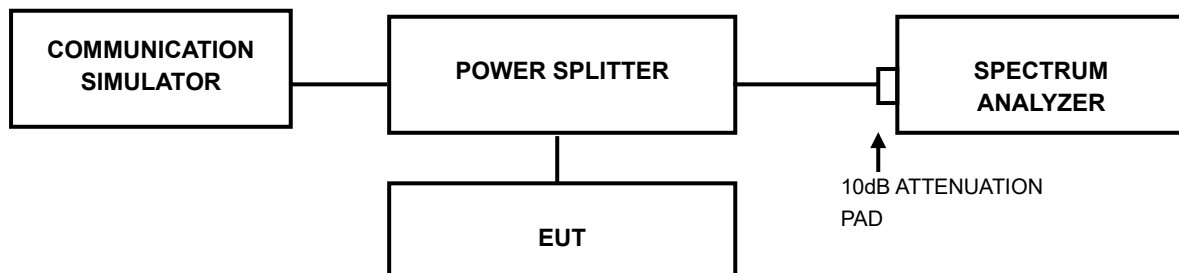

3.7.3 TEST PROCEDURES

1. Set resolution/measurement bandwidth \geq signal's occupied bandwidth;
2. Set the number of counts to a value that stabilizes the measured CCDF curve;
3. Record the maximum PAPR level associated with a probability of 0.1%.

3.7.4 TEST RESULTS

Please Refer to module EM060K-GL and EM120K-GL report.

For module EM060K-GL: Report No.: 2309RSU052-U2, 2309RSU052-U3

FCC ID : XMR2022EM060KGL

For module EM120K-GL: Report No.: 2203RSU046-U3, 2203RSU046-U4

FCC ID : XMR2022EM120KGL



Test Report No.: PSU-NQN2504020112RF05

4 INFORMATION ON THE TESTING LABORATORIES

We, Huarui 7layers High Technology (Suzhou) Co., Ltd. ,were founded in 2020 to provide our best service in EMC, Radio, Telecom and Safety consultation. Our laboratories are accredited and approved according to ISO/IEC 17025.

Huarui 7Layers High Technology (Suzhou) Co., Ltd.

Lab Address:

Tower N, Innovation Center, 88 Zuyi Road, High-tech District, Suzhou City, Anhui Province

Accredited Test Lab Cert 6613.01

If you have any comments, please feel free to contact us at the following:

Suzhou EMC/RF Lab:

Tel: +86 (0557) 368 1008



**BUREAU
VERITAS**

Test Report No.: PSU-NQN2504020112RF05

5 MODIFICATIONS RECORDERS FOR ENGINEERING CHANGES TO THE EUT BY THE LAB

No modifications were made to the EUT by the lab during the test.



**BUREAU
VERITAS**

Test Report No.: PSU-NQN2504020112RF05

6 APPENDIX

Please Refer to module EM060K-GL and EM120K-GL report.

For module EM060K-GL: Report No.: 2309RSU052-U2, 2309RSU052-U3

FCC ID : XMR2022EM060KGL

For module EM120K-GL: Report No.: 2203RSU046-U3, 2203RSU046-U4

FCC ID : XMR2022EM120KGL

---END---