

PLAY FOR DREAM MR

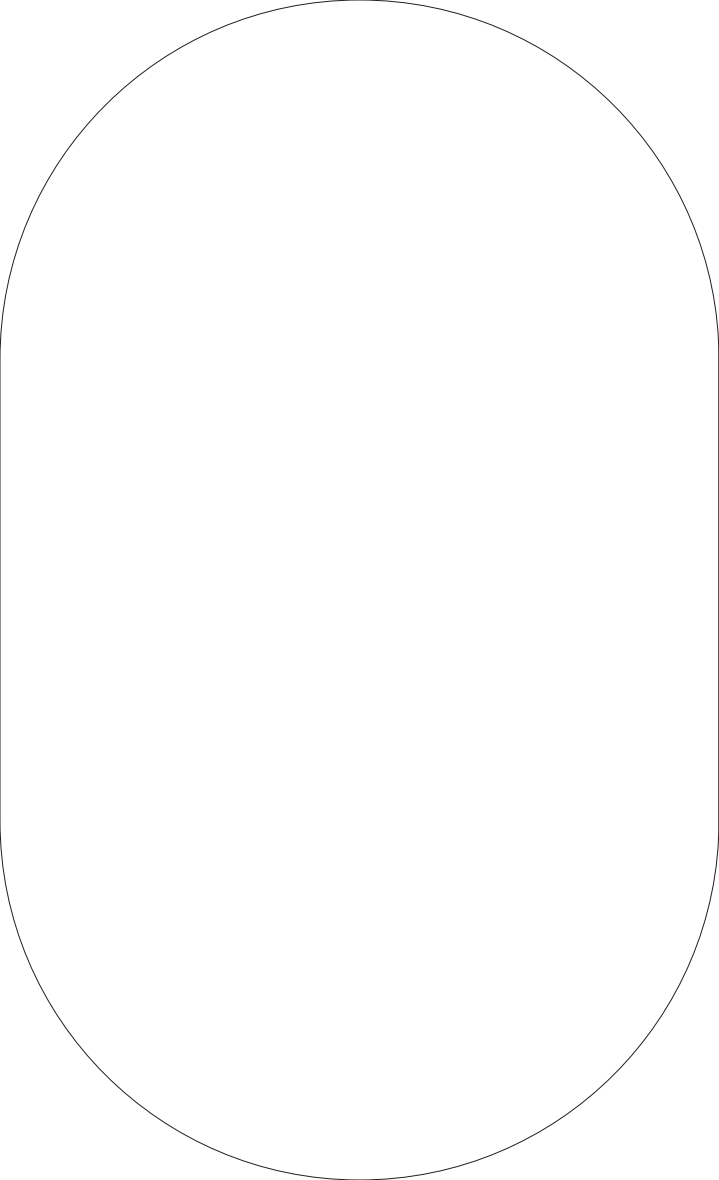

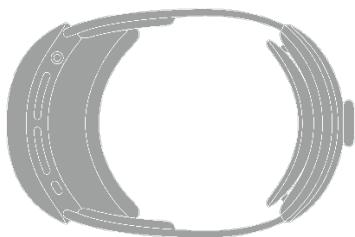

1. In the Box



Play For Dream MR

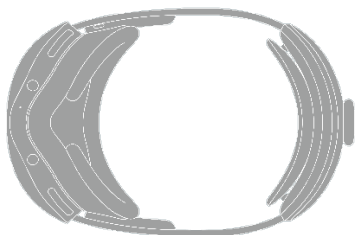

Lens Cleaning Cloth

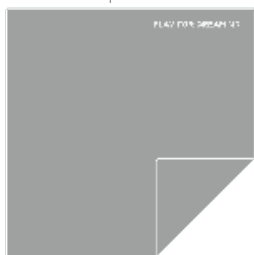

Multifunctional
USB-C to USB-C
Cable



45W
Power Adapte



Charging
Cable Clip



Light Seal Cushion



Controller Charging Cable
with One USB-A
and Two USB-C Ports

Controller



2. Hardware





USB-C Charging / Data Port

Light Seal Cushion

Fit Dial



3. Wearing MR Headset



- 1 If you wear glasses, remove them and then attach the custom magnetic prescription lenses onto the optical lenses before wearing the Play For Dream MR Headset.



- 2 Adjust the knob and enlarge the headband to a size that can be easily worn.

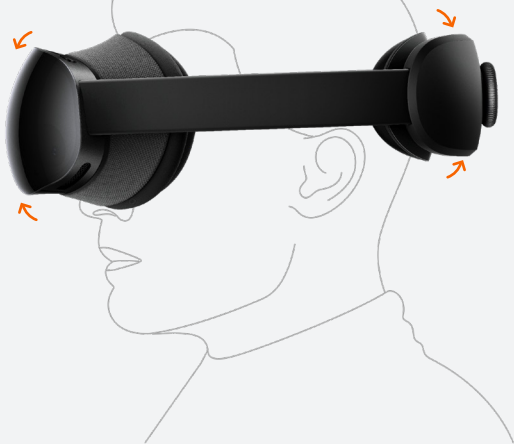

- 3 Fine-tune the MR device's position up and down until the field of view is clear, then adjust the knob to set the headband's tightness to a comfortable position.

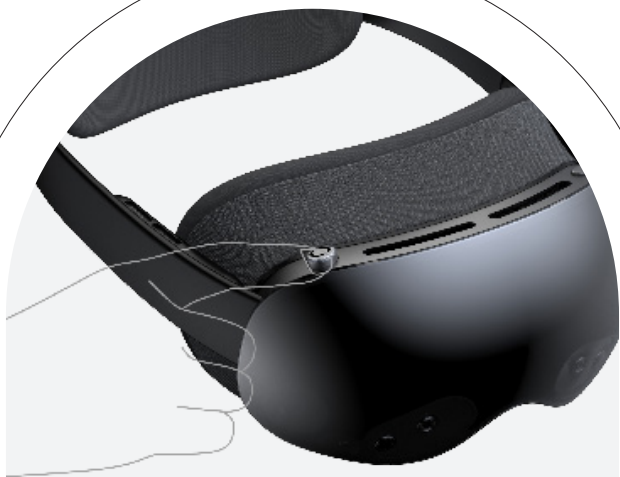

- 4 Adjust the top knob and long press to adjust the interpupillary distance until the field of view is clear.

4. Using MR Headset



2

1

1 Top Button

Power On: Press and hold for 1.5s

Power Off: Press and hold for 4s

Quick Action (Open the camera): Short press

2 Digital Dial

Open Home Page: Short press

Recenter: Press and hold for 1.5s

Immersion/Volume Adjustment: Rotate

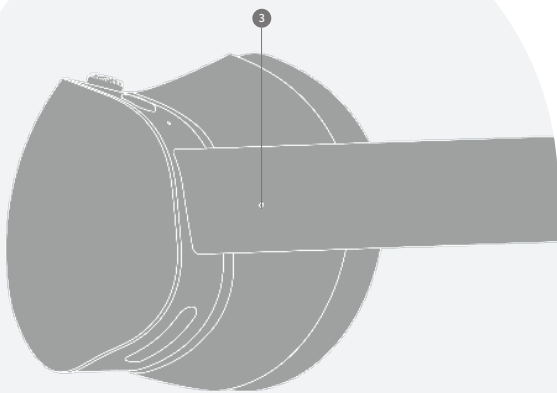

3 ① White

Solid: Headset is on, and battery level is greater than 10%

Off: Headset is in sleep mode or powered off, or screen is off

Flashing: Headset is powering on or rebooting

② Red

Solid: Low battery (10% or less)

③ Orange

Solid: Charging

④ Green

Solid: Charging complete

⑤ Blue

Flashing: Factory reset

⑥ Purple

Solid: Recording mode

Flashing: Headset is recording video

5. Using Controllers

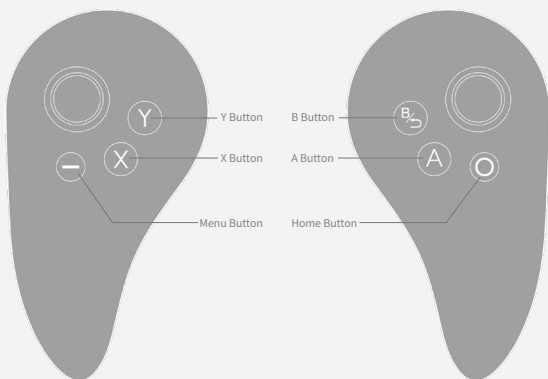

Buttons

① Home Button (Right Controller)

Power On: Short press

Power Off: Press and hold for 5s

Recenter: Press and hold for 1s

② Menu Button (Left Controller)

Power On: Short press

Power Off: Press and hold for 5s

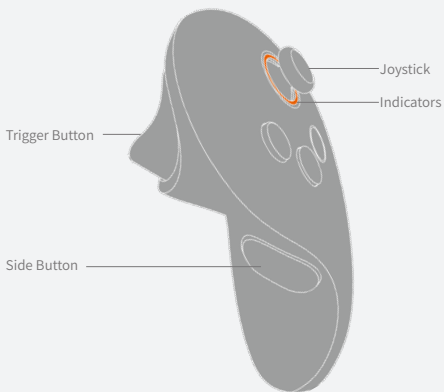

Indicators

① White

Flashing: Controller is powering on or waking up

② Red

Solid: Low battery (10% or less)

Flashing: Critically low battery; Controller is about to shut down

③ Orange

Solid: Charging

④ Green

Solid: Charging complete

⑤ Blue

Flashing: Pairing

6. Care and Maintenance

1. Methods

- Be sure to use the lens cleaning cloth provided with the product to wipe clean the lenses.
- Use a dry, soft cloth to wipe clean the other parts of the MR Headset.
- Do not use alcohol, paint thinner, or benzene on the lenses or other parts of the MR Headset.
- Protect the lenses from hard objects during use and storage to prevent scratches.

2. Cycle

- Maintain the MR Headset and controllers according to the above methods before and after each use.
- Gently hand wash the Light Seal Cushion with clean water regularly and dry it in a place away from direct sunlight.
- Use cotton swabs to remove dust from the USB port, exposed sensors, and any nooks and crannies in between the Light Seal Cushion and the Headset and other parts of the Headset regularly to prevent dust from accumulating.
- If you are looking for replacements for faulty parts, please contact Play For Dream's Customer Service Center.

Note: The Light Seal Cushion may discolor or show signs of wear after being cleaned and disinfected many times. It is recommended to replace the Light Seal Cushion when necessary. If you need to purchase it separately, please contact Play For Dream or an authorized retailer.

Play For Dream's Customer Service Hotline: 400-618-1160

7. Regulatory Information

You can view the certification and regulatory information on this product in your region by accessing the universal menu and navigating to "Settings" > "General" > "About".

This device complies with Part 15 of the FCC Rules. Operation is subject to the following two conditions: (1) this device may not cause harmful interference, and (2) this device must accept any interference received, including interference that may cause undesired operation.

8. Safety Precautions

Please read the following warnings and information carefully before using this product and follow all guidelines on safety and operation. Failure to follow these guidelines may result in discomfort, physical injuries (including electric shock, fire, and other injuries), or property damage.

If you allow others to use this product, you must ensure every user of your MR Headset understands and follows all safety and operational instructions.

1. Health and Safety Warnings

- Ensure a safe environment for your MR journey. When you use this product to immerse yourself in a virtual environment, you are not able to see your surroundings. Move only within the safe area you create and always be aware of your surroundings while using the MR Headset. Do not go near stairs, windows, heat sources, or other potential hazards.
- Use this product only when you are in good health. Pregnant women, elderly people, or people with serious physical, mental, visual, or heart problems should consult a doctor before using the MR Headset.
- Some people may experience epilepsy, fainting, severe dizziness, and other symptoms triggered by light flashes or patterns, even if they have no such medical history. Consult a doctor before using the MR Headset if you have a similar medical history or have ever experienced any of the symptoms.
- Some people may experience severe dizziness, vomiting, palpitations, and even fainting when using MR headsets, playing ordinary video games, and watching 3D movies. Consult a doctor if you have experienced any of the listed symptoms.
- You are advised to wear the MR Headset with custom magnetic prescription lenses if you have a significant difference in binocular vision, high myopia, astigmatism, or hyperopia.
- Some people may be allergic to plastic, leather, fabric, and other materials used in the MR Headset. Prolonged contact with the product may cause redness, swelling, and inflammation. Stop using the MR Headset and consult a doctor if you experience any of the symptoms.
- Stop using the MR Headset immediately if you experience visual abnormalities (diplopia, sight distortion, eye discomfort or pain, etc.), excessive sweating, nausea, vertigo, palpitations, disorientation, loss of balance, or show other signs of distress.

- The MR Headset provides access to immersive virtual reality experiences. Some types of content may cause discomfort. If you experience any discomfort, stop using the product immediately. If the discomfort persists, please consult a doctor.

- Do not use this product while performing activities that require intense focus, such as driving, cycling, operating machinery, and the like.

- This product has received TÜV Rheinland's hardware-level Low Blue Light certification, effectively reducing the impact of high-energy blue light on the eyes. It is recommended that you take a break of at least 10 minutes every 30 minutes when using the MR Headset. If you experience any discomfort, you may reduce the time of use or lengthen the period of break as needed.

2. Contagious Conditions

- To avoid transmitting contagious conditions (e.g., pink eye), do not share your MR Headset with people who suffer from contagious conditions, infections, or illness, particularly of the eyes, skin, or scalp. Clean the Light Seal Cushion and controllers between each use. Replace the Light Seal Cushion if it is worn or cannot be cleaned.

3. Electronic Devices

- Do not use the MR Headset at places where the use of radio-transmitting devices is expressly prohibited, because the MR Headset could cause interference with other electronic devices or create other hazards.

4. Impact on Medical Devices

- In medical and healthcare settings where the use of radio-transmitting devices is expressly prohibited, you are advised to shut down your MR Headset and its accessories.

- Radio waves generated by the MR Headset and its accessories may affect the normal operation of nearby implantable medical devices or personal medical devices, such as pacemakers, cochlear implants, and hearing aids. Consult the manufacturer of your medical device before using your MR Headset.

- Keep a distance of at least 15cm from any implanted medical devices (pacemakers, cochlear implants, etc.) when your MR Headset and its accessories are connected by Bluetooth.

5. Operating Environment

- To avoid harm to your eyes, do not look directly at strong light with the MR Headset.
- Do not use the MR Headset in dusty, damp, dirty environments or places near magnetic fields to prevent damage to internal circuits.
- Do not use the MR Headset during a thunderstorm, which may cause device failure and increase the risk of an electric shock.
- The ideal temperature for using the MR Headset is 0-35° C / 32-95° F. Store the MR Headset and its accessories at -10-45° C / 14-113° F. Temperatures higher or lower than this range may cause device failure.
- Do not expose your MR Headset and its accessories to rain or moisture to prevent fire hazards or electric shocks.
- Do not place the MR Headset near heat sources or exposed flames, such as electric heaters, microwave ovens, ovens, water heaters, stoves, candles, or areas that may get very hot.
- It is normal for your MR Headset to feel warm to the touch after it is used for a while. Avoid prolonged skin contact with a headset that is hot to touch to prevent low-temperature burns, skin redness, swelling, or pigmentation.
- Do not apply excessive pressure to the MR Headset when it is in use to avoid damage to the Headset, lenses, and your face.
- Do not use strong chemicals, cleaning agents, or detergents to clean the MR Headset or its accessories. Improper cleaning can damage the Headset and increase the risk of eye/skin injury.
- If an external battery is used, please store it properly and always remember its location to avoid potential hazards.

6. Children's Health

- The MR Headset and its accessories may contain small parts. Children may unintentionally damage the Headset and its accessories or swallow small parts, which could lead to choking or other hazards. In light of this, please place the Headset and its accessories out of the reach of children.
- Minors should not use the Headset without adult supervision, and the time they spend using the Headset should be limited.

7. Requirements for Accessories

- The MR Headset is designed for use only with approved accessories that are compatible with the Headset model. The use of non-approved accessories may cause safety incidents, inflict damage not covered by your warranty, and violate the relevant regulations of the country where the MR Headset is used. Contact Play For Dream's Customer Service Center to obtain approved accessories.

8. Environmental Protection

- Dispose of the Headset and accessories separately from household waste.
- Comply with your local regulations regarding the disposal of the Headset and its accessories, and support recycling initiatives.

9. Hearing Protection

- Do not listen at high volume for a long time to prevent possible hearing damage.
- It is recommended that you use the minimum volume possible to protect your hearing when listening to music, playing games, or watching movies with the Headset. Prolonged exposure to high volume may cause permanent hearing damage.

10. Hazardous Areas

- Do not use the MR Headset at a petrol station (repair station) or anywhere near flammable or explosive materials, chemicals, or other hazardous sources. Be sure to follow all the graphic or textual instructions and warnings on the site. We advise you to turn off the accessories connected to your MR Headset when you are in hazardous locations, such as areas dedicated to the storage and transportation of fuel and chemicals, or anywhere within or near potentially explosive areas, because the accessories may cause an explosion or fire.
- Do not store or transport the MR Headset and its included accessories with combustible and explosive liquids, gases, or other similar substances in the same container.

11. Transportation Safety

- Do not use the MR Headset in situations that require attention, such as walking, cycling, or driving.
- Do not use the MR Headset in a location that may be subject to shaking or other unstable conditions, as this may increase the pressure in your eyes and brain. Stop using the Headset immediately if you experience any discomfort.

12. Charging Safety

- We recommend that you use the power adapter included in the product package to ensure optimal charging efficiency. Using other power adapters may damage the Headset.
- Use an electric socket that is close to the MR Headset and easily accessible while charging.
- We advise you to unplug the charger from the MR Headset and disconnect it from the electric socket when charging is complete or discontinued.
- Do not drop or expose the charger to strong physical impact.
- Immediately stop using the power adapter or charging cable when it is damaged, as using a damaged power adapter or charging cable may cause a fire or electric shock.

- Do not touch the power plug with wet hands or unplug the charger by tugging the charging cable.
- Do not touch the MR Headset or charger with wet hands, as this may result in short circuits, failure, or electric shocks.
- Do not use the charger if it is exposed to rain, liquids, or severe moisture.

13. Battery Safety

- Your MR System (including both the headset and controllers) contains lithium polymer batteries. Do not connect any metal conductors to the two electrodes or terminals of the battery to prevent short circuits and physical injuries, such as burns, caused by overheating batteries.
- Do not expose the batteries to high temperatures or places near heat sources, such as sunlight, stoves, microwave ovens, ovens, and water heaters, as overheating can lead to battery explosion.
- Do not disassemble or modify the batteries, insert anything into the batteries, or soak the batteries in any liquids, to avoid battery leaks, overheating, fire, or explosion.
- If the battery leaks, avoid skin and eye contact with the leakage. In case of skin or eye contact, immediately flush with clean water and seek medical attention.
- Avoid dropping, squeezing, or piercing the batteries. Do not expose the batteries to strong external stress to avoid internal short circuits and overheating.
- The MR Headset's built-in battery is not removable. Do not attempt to replace the battery by yourself. Doing so may result in hazards such as battery damage, overheating, fire, or bodily injuries. The non-removable battery can be replaced only by Play For Dream or service providers authorized by Play For Dream. Replacing the battery with an incorrect model may cause an explosion.
- Note: Replacing the battery with an incorrect model may cause an explosion. Be sure to dispose of the battery according to the instructions.

14. Device Safety

- Do not use the MR System if any part of it is damaged.
- Do not repair the MR System by yourself. Contact the customer service if you need repair services.
- Do not expose the headset and controllers to moisture, excessive dust, direct sunlight, or temperatures beyond their operating temperature range to avoid damage to the MR System.
- Store the MR Headset and its accessories properly to keep them from pet bites.

15. Lens Maintenance

- Keep the MR Headset, especially the lenses, away from places exposed to direct sunlight or ultraviolet rays such as outdoors, balconies, windowsills, and automobile dashboards. Such exposure may cause permanent yellow spots on the screen.
- Be sure to avoid such exposure. This type of damage is not covered by the warranty.

16. Declaration of Toxic and Hazardous Substances

Toxic and Hazardous Substances or Elements						
Components	Lead (Pb)	Mercury (Hg)	Cadmium (Cd)	Hexavalent Chromium (Cr(VI))	Polybrominated Biphenyls (PBB)	Polybrominated Diphenyl Ethers (PBDE)
Optical Components	○	○	○	○	○	○
Structural Components	○	○	○	○	○	○
Circuit Modules	✕	○	○	○	○	○
Batteries	✕	○	○	○	○	○
Cables	✕	○	○	○	○	○
Printed and Packaging Materials	○	○	○	○	○	○

This table is compiled according to the provisions of SJ/T 11364.

○ indicates that the content of the hazardous substance in all homogeneous materials of the component is below the limit specified in GB/T 26572.

× indicates that the content of the hazardous substance in at least one homogeneous material of the component exceeds the limit specified in GB/T 26572. All items marked with "×" comply with the requirements of the EU RoHS Directive (2011/65/EU) and its exemptions.

Circuit Modules:

Lead is present in the ceramics or glass of electronic components, and in the solder used to form reliable connections between semiconductor devices and carriers in the flip chips of the integrated circuits.

The environmentally-friendly use period of this product, if used within the temperature and humidity ranges specified in this User Guide, is 10 years. This means that, within ten years from the manufacturing date, the hazardous substances contained in the MR System will not leak or mutate if it is used in compliance with this User Guide, and the normal use of the product by users will not cause environmental pollution, physical harm, and financial damage. When the environmentally-friendly use period expires, please classify recyclable and non-recyclable items.

9. Warranty Statement

1. Play For Dream Limited Warranty Statement

● Please read this Limited Warranty Statement carefully to understand your rights and obligations. By using Play For Dream products or accessories, you agree to be bound by this Limited Warranty Statement. This Warranty Statement is applicable to Play For Dream products officially sold in the mainland of the People's Republic of China (excluding Hong Kong, Macao, and Taiwan). Play For Dream provides customers with a warranty on the products purchased from Play For Dream or retailers authorized by Play For Dream. Play For Dream is not responsible for any retailer's promises that are not approved by Play For Dream.

2. Scope and Terms

● This Warranty only applies to Play For Dream-branded all-in-one devices and accessories sold by Play For Dream in the Chinese mainland, with the exception of giveaways and packaging. For Play For Dream-branded products sold by authorized third-party sellers, Play For Dream only provides repair services within the warranty scope. For returns or exchanges, please contact the seller from whom you purchased the product. We warrant that the product will, under normal and intended use, function substantially in accordance with our technical specifications during the warranty period. If Play For Dream software or services are needed for the product to perform the warranted functions, we will provide the required software and services during the warranty period. To the extent that it does not violate any laws, regulations, and other mandatory provisions, we have the discretion to update, modify, or restrict the content of such software and services in whole or in part, but we will use reasonable efforts to provide you with warranty service for such software and services.

3. Warranty Policy

- Within the warranty period in accordance with this Limited Warranty, you are entitled to:
- a replacement, refund, or repair in the event of a quality issue arising within seven (7) days from the purchase date;
- a replacement or repair in the event of a quality issue arising within fifteen (15) days from the purchase date;

- a repair in the event of a quality issue arising within twelve (12) months from the purchase date;
- a three (3) month warranty on the accessories of the MR Headset, including the Light Seal, Light Seal Cushion, and other consumables.

4. Important Notes

The following are not covered by this Warranty (replacement, refund, and repair):

- Damage due to use, maintenance, and storage not in accordance with this User Guide;
- Exposure to direct sunlight or contact with liquid;
- Giveaways and packaging external to the product;
- Damage due to accidental or human factors;
- Damage caused by disassembly, modification, or maintenance by unauthorized service providers;
- Damage caused by the use of third-party software or accessories;
- Damage caused by force majeure, such as fire, flood, and lightning;
- Products beyond the Limited Warranty period;
- Screen damage caused by direct sunlight.

5. Warranty Service

If you cannot find solutions to your problem by referring to the User Guide, you may contact the seller from whom you purchased the product or accessories, or Play For Dream Customer Service Center for further information and assistance.

You need to provide the following information to help us provide the services:

- The product or accessory's model and serial number;
- Full mailing address and contact information;
- Proof of purchase: original invoice, receipt, or sales ticket. Valid proof of purchase is required to make a warranty claim in accordance with this Limited Warranty Statement. Play For Dream is not obligated to provide the support and services under this Limited Warranty Statement if no valid proof of purchase is provided.

Before you ship the product or accessories to us for warranty service, be sure to back up all the data stored on your MR Headset and remove any confidential, messaging, or personal information from the Headset. If you have logged in to your personal account on your MR Headset, be sure to log out before sending the Headset back for service to protect your legitimate rights and interests.

- Play For Dream is not responsible for the corruption or loss of any programs or data that you have not backed up.
- If Play For Dream or a service provider authorized by Play For Dream detects any defect or fault, we will repair or replace the product to ensure its normal functionality.
- If the product falls out of the warranty coverage, Play For Dream will charge you a service fee for the repair and provide you with a repair report.
- The repaired or replaced product will continue to be warranted for the remaining time of the original warranty period or within ninety (90) days after you receive the repaired or replaced product, whichever is longer.

6. Laws Applicable to This Warranty

- This Warranty is governed by the laws and regulations in the mainland of the People's Republic of China. Should relevant laws and regulations provide mandatory provisions regarding the application of law, such mandatory provisions shall apply.

10. Statement of Interest

- Play For Dream (Shanghai) Technologies Co., Ltd. reserves all rights.
- This documentation is for reference only. The actual product may vary.

11. Software License

- If you use the software products and other related services we provide, of which one or several products and services have their respective user agreements, please carefully review these user agreements. By using relevant software and services, you agree to be bound by the terms and conditions stated in the corresponding user agreements.

12. Privacy Policy

- You can find information on how we collect, use, disclose, protect, store, and transmit your personal information in the privacy policy provided on Play For Dream's official website or by the relevant product or service. If one or several of the services or products we provide to you have their respective privacy policies, the use of such services or products shall be subject to their respective privacy policies. To find more information about our products, please visit Play For Dream's official website or follow Play For Dream's WeChat official account.

NOTE: This equipment has been tested and found to comply with the limits for a Class B digital device, pursuant to part 15 of the FCC Rules. These limits are designed to provide reasonable protection against harmful interference in a residential installation. This equipment generates, uses and can radiate radio frequency energy and, if not installed and used in accordance with the instructions, may cause harmful interference to radio communications. However, there is no guarantee that interference will not occur in a particular installation. If this equipment does cause harmful interference to radio or television reception, which can be determined by turning the equipment off and on, the user is encouraged to try to correct the interference by one or more of the following measures:

- Reorient or relocate the receiving antenna.
- Increase the separation between the equipment and receiver.
- Connect the equipment into an outlet on a circuit different from that to which the receiver is connected.
- Consult the dealer or an experienced radio/TV technician for help.

This device complies with part 15 of the FCC Rules. Operation is subject to the following two conditions: (1) This device may not cause harmful interference, and (2) this device must accept any interference received, including interference that may cause undesired operation.

Any Changes or modifications not expressly approved by the party responsible for compliance could void the user's authority to operate the equipment.

Transmitters in the 5.925-7.125 GHz band are prohibited from operating to control or communicate with unmanned aircraft systems.

RF Exposure Information (SAR) :

This device meets the government's requirements for exposure to radio waves. This device is designed and manufactured not to exceed the emission limits for exposure to radio frequency (RF) energy set by the Federal Communications Commission of the U.S. Government.

The exposure standard for wireless devices employs a unit of measurement known as the Specific Absorption Rate, or SAR. FCC head SAR 1g report SAR limit 1.6W/kg.FCC limb SAR 10g report SAR limit 4W/Kg.PD FCC limit 10W/m²@4cm². Tests for SAR are conducted using standard operating positions accepted by the FCC with the device transmitting at its highest certified power level in all tested frequency bands.

Play For Dream App

- Discover and purchase quality MR apps.
- Find out what's new with MR around the globe.
- Share your incredible experiences in using Play For Dream products with your family and friends.

Download Play For Dream Mobile Assistant to unlock more MR adventures with your friends.



Pair Play For Dream Mobile Assistant with MR Headset

Method 1:

1. Connect Play For Dream Mobile Assistant and the MR Headset to the same network.
2. Install and open Play For Dream Mobile Assistant and choose "Device" > "Search for devices nearby". The app will automatically search for and pair with the device.

Method 2:

1. Log in to the MR Headset and Play For Dream Mobile Assistant using the same account, and the device will appear on the Device page of the app.

Official Website: www.pfdm.cn
Customer Service: 400-618-1160

After-Sales Service: yvrservice@yvr.cn





FOR DTS PATENTS, SEE [HTTP://XPERI.COM/DTS-PATENTS/](http://XPERI.COM/DTS-PATENTS/). MANUFACTURED UNDER LICENSE FROM DTS, INC. AND ITS AFFILIATES. DTS, DTS:X, THE DTS:X LOGO, AND DTS:X ULTRA ARE REGISTERED TRADEMARKS OR TRADEMARKS OF DTS, INC. AND ITS AFFILIATES IN THE UNITED STATES AND/OR OTHER COUNTRIES. © DTS, INC. AND ITS AFFILIATES. ALL RIGHTS RESERVED.

IMAX[®]
ENHANCED

IMAX[®] **dts.**

Manufactured under license from IMAX Corporation. IMAX[®] is a registered trademark of IMAX Corporation in the United States and/or other countries. For DTS patents, see <http://patents.dts.com>. Manufactured under license from DTS, Inc. (for companies headquartered in the U.S./Japan/Taiwan) or under license from DTS Licensing Limited (for all other companies). DTS and the DTS logo are registered trademarks or trademarks of DTS, Inc. in the United States and other countries.

© 2020 DTS, Inc. ALL RIGHTS RESERVED.

