

ROBOTIC POOL CLEANER

Instruction Manual



Product Model (WC-3010)

Please read all information in the Manual carefully before using the product.

Please properly keep this Manual for future reference.

Table of Contents

I. Product Introduction	1
II. Warnings and Safety Precautions	1
III. Unpacking, Functions, and Operating Instructions	2-5
IV. Daily Maintenance	6-8
V. Failure Message and Handling	7
VI. Product Parameter List	9
VII. Product Exploded View and Replaceable Accessory List	10
IX. Storage car (optional) usage method	11
X. Aftersales Information (Limited to Domestic Products)	12

I. Product Introduction

The Swimming Pool Cleaning Robot is a fully automatic vacuum cleaner for swimming pools, and mainly used to clean hairs, leaves, and sand grains in the swimming pool, and sweep and brush dirt, and other stains on the bottom, walls, and lane lines of the swimming pool. You just need to set up the corresponding mode and put the cleaning robot in the swimming pool, it will start a fully automatic cleaning, design the cleaning route automatically, and leave you with a clean and neat swimming pool.

II. Warnings and Safety Precautions

- Warning – Don't enter the swimming pool while the cleaning robot works.
- Warning – Unless under the close supervision of parents, children are not allowed to use this product.
- Warning – Don't use the cleaning robot out of the water; otherwise, the motor sealing will be damaged, and the quality warranty will be invalid.
- Warning – While taking the cleaning robot out of the water, please be sure to hold the handle rather than pulling the cable.
- Warning – The cleaning robot works at a water temperature of 5-35°C, at a water depth of 0.5M-3M, and with a cleaning area of less than 200M².
- Warning – Robot charging should avoid direct sunlight and be placed in a dry place as much as possible..

III. Unpacking Instructions

As shown in the figure below, find a flat ground, unpack the packaging box, and take the Instruction Manual, power control cabinet, and cleaning robot out of the box. Don't throw the packaging materials away, and please place them in the storeroom or the local recycling site;

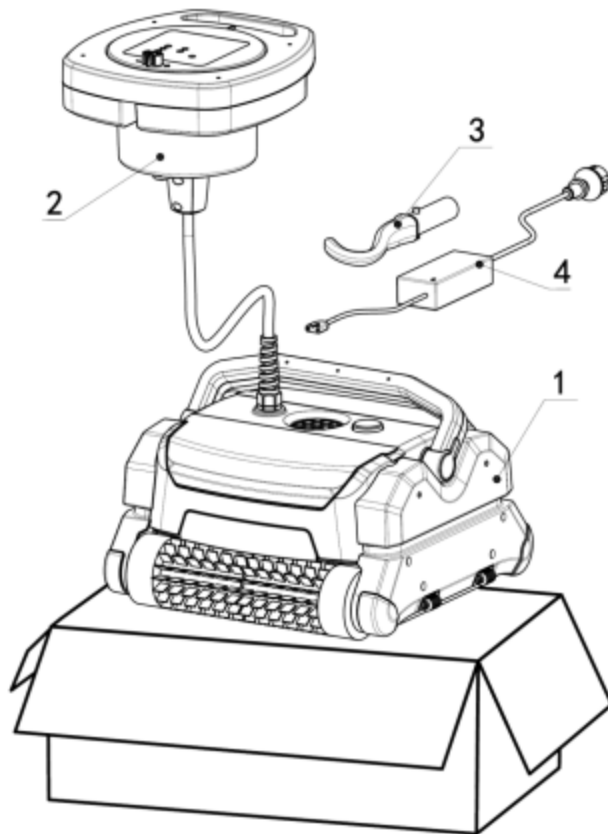

1. Main unit
2. Floating battery box
3. Salvage hook
4. Charger

Functions and Operating Instructions

Basic functions:

1. Start/stop: Touch button, robot work switch;
2. MODE: BOTTOM: clean the pool bottom;
ALL: clean the entire pool;
3. TIME: Automatic operation for more than 3.5 hours;
4. Mobile Bluetooth APP intelligent control,
Android or iOS (Apple Store Keywords: Robotic Pool Cleaner)



Operating Instructions:

1. Control panel operation and instructions:

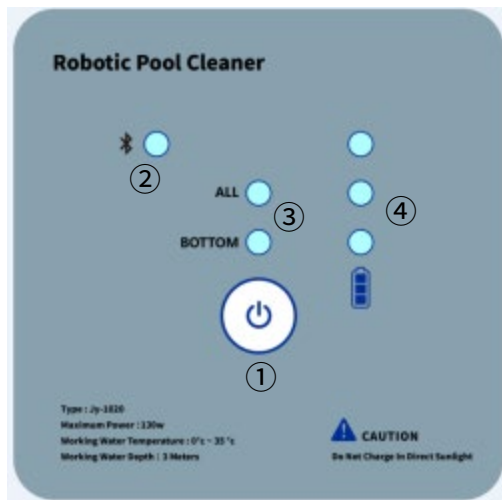

1. On/off button touch button, press for 3 seconds to turn on/off, press for 1 second to switch working mode;
2. Bluetooth connection indicator light, lit up to indicate successful connection;
3. Work mode indicator light;
4. battery indicator;

2. After long pressing for 3 seconds to turn on the machine, the robot on land will not run. It must be placed together with the power control box in the swimming pool water and automatically run. When the robot runs out of battery, it will automatically lean against the wall and can be used in conjunction with a fishing hook to retrieve the water surface for charging.

3. Charging operation instructions:

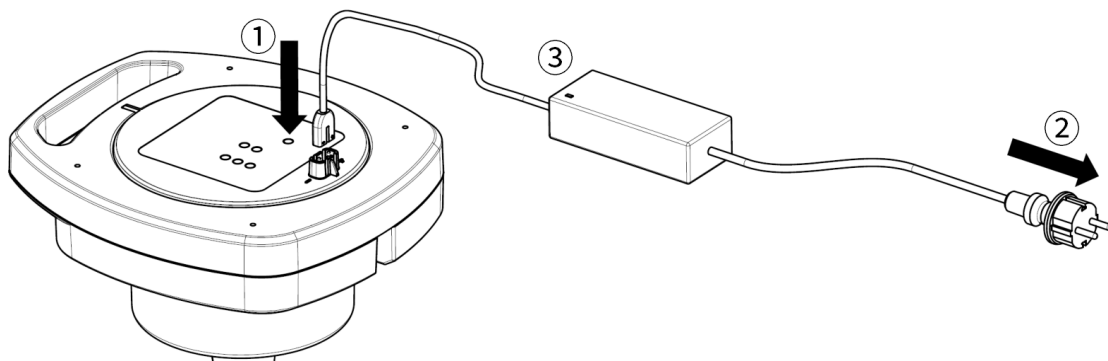

- ①. Insert corresponding interface;
- ②. Insert power supply;
- ③. Check the indicator light, the red light is not full and the green light is full;

Warn: **1. Do not try to avoid sunlight or high temperature environments (below 35 degrees Celsius) when charging.**

2. Do not knock or impact the battery control box to avoid explosion or combustion;

4. Information indicated by the LED indicator lights:

Name	Color	Status	Function description
Work indicator light	Green	Breathing light	Standby
		Solid	Working
	Red	Solid	Warning indication
Mode light	Green	Solid	The BOTTOM Mode or the ALL Mode is selected
battery indicator	Green	Solid	Three grid battery indicator
optional feature	blue	Solid	Bluetooth APP connection successful

5.Contents of failure warning sounds:

Contents of failure warning sounds:				Troubleshooting:	Restore operation:
One beep	Short	2S	No-load failure	1. Check if the robot has run out of the swimming pool; 2. Check if the robot's water outlets spiral fan blades are broken; Maintenance and replacement required Parts;	1. Start/stop button (long press for 5 seconds); 2. Unplug the plug, turn off the power, and when the work indicator light is not on, plug in the power;
Two beeps	Short	2S	Overload failure	1. Check whether the cleaning drum and transmission belt are blocked by foreign objects; 2. Check if the spiral fan blades of the robot's water outlet are stuck by foreign objects;	
Three beeps	Short	2S	Communication failure	1. Check if the controller is correctly connected to the robot socket; 2. Damaged wires or PCB motherboard, requiring repair and replacement of parts;	

IV. Daily Use and Maintenance

1. Clean the filter basket

After the cleaning robot stops, pull out the power plug of the control cabinet, open the upper cover of the cleaning robot, and take out the filter basket. After washing the filter basket with a hydraulic giant, put it back into the cleaning robot.

Note: Before washing the filter basket, turn off or cut off the power supply of the cleaning robot. Thoroughly wash the filter basket after each working cycle, and put it in a clean and dry place, ensuring its optimum performance in the next working cycle.

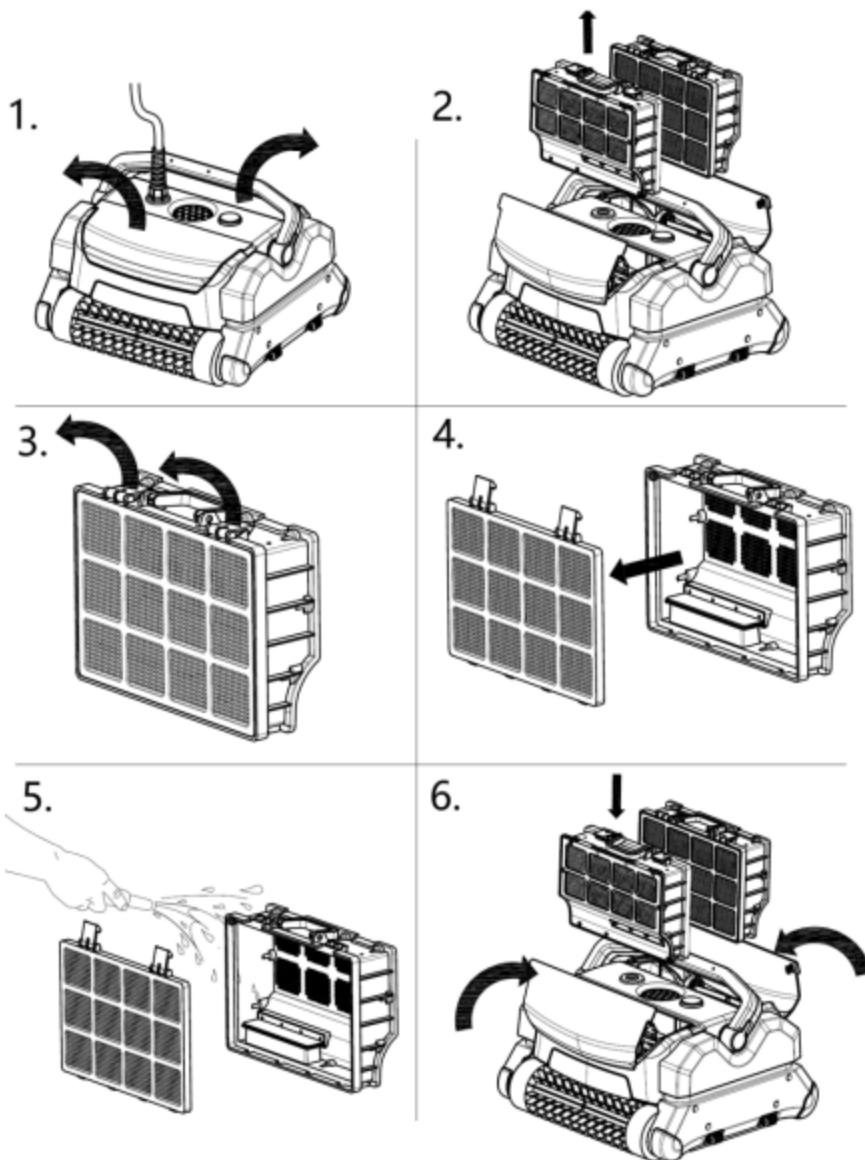

2.How to change the cleaning roller

1) Insert it into the holes indicated with the arrows, as shown in the figure below;



2) Take out the cleaning roller, as shown in the figure below;

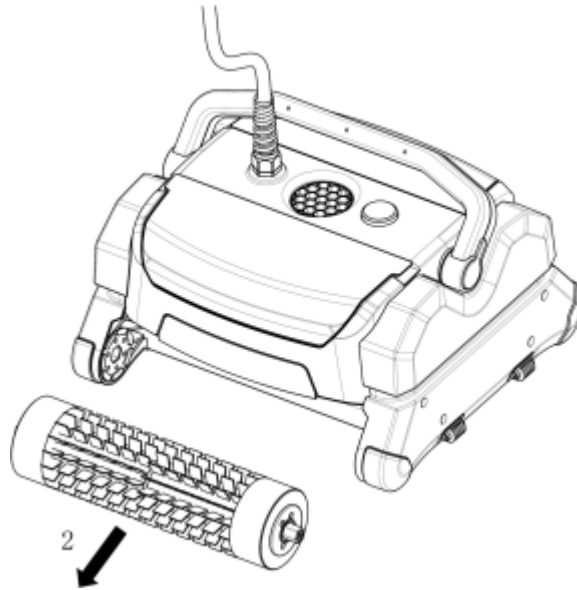

3. Selection of filter screen

Coarse mesh

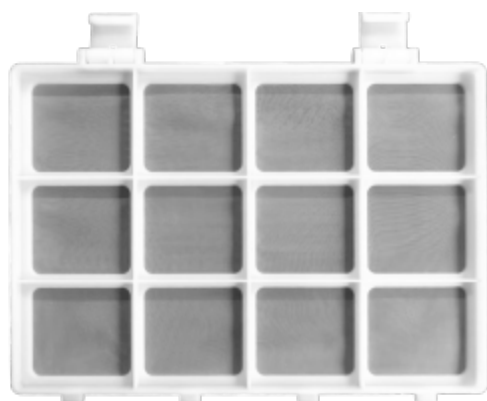

Fine mesh

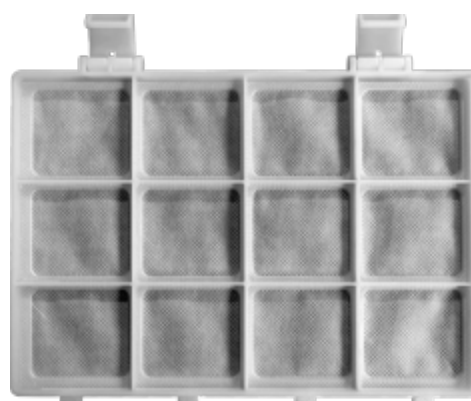

Coarse mesh is suitable for any water quality environment, with a filtration accuracy of 0.1mm.

Fine mesh is suitable for clear water quality environments, with a filtration accuracy of 5um. It is recommended to clean the bottom of the pool mode.

V. Failure Message and Handling

Failure phenomenon	Cause analysis	Solution
Poor dirt suction effect	The filter basket is blocked	Clean the filter basket
The cleaning robot cannot sink into the water after it starts to work	The filter basket is blocked	Clean the filter basket
The cleaning robot starts to work, and then stops	The impeller may be blocked by debris	Check and clear away the debris
	The driving belt is blocked by debris	Check and clear away the debris
Debris comes out of the upper water outlet	The filter basket is damaged	Check the filter basket, and if damaged, replace the filter basket
	The filter basket is overloaded	Wash the filter basket
The floating power cable is twisted together	Working for a long time	Disentangle the power cable
Stop working (the LED light is red)	Overload or no-load protection	After submerging the cleaning robot in the water again, press the start/stop key (for 5 seconds) to turn it on.

VI. Product Parameter List

Features/function:	
Product dimensions	428 x 400x 280 mm
Packaging dimensions	530x450x480 mm 、 530X450X630 mm (Storage car)
Product weight	About 14 KG
Total weight of the packed product	About 15 KG
Scope of application	Pool bottom, pool waters, and lane lines
Filter precision	0.1mm/5um
Length of the floating power cable	17m/25m
Filtration rate	25 m ³ /h
Quality warranty	1 year
Battery capacity	12800mah
Output current	4A
Charging Voltage	110V~230V
Working hours	>3.5h
Charging time	3h
Power	MAX 130W
Waterproof level of battery control box	IP68
Robot waterproof level	IP68

VII. Product Exploded View and Replaceable Accessories

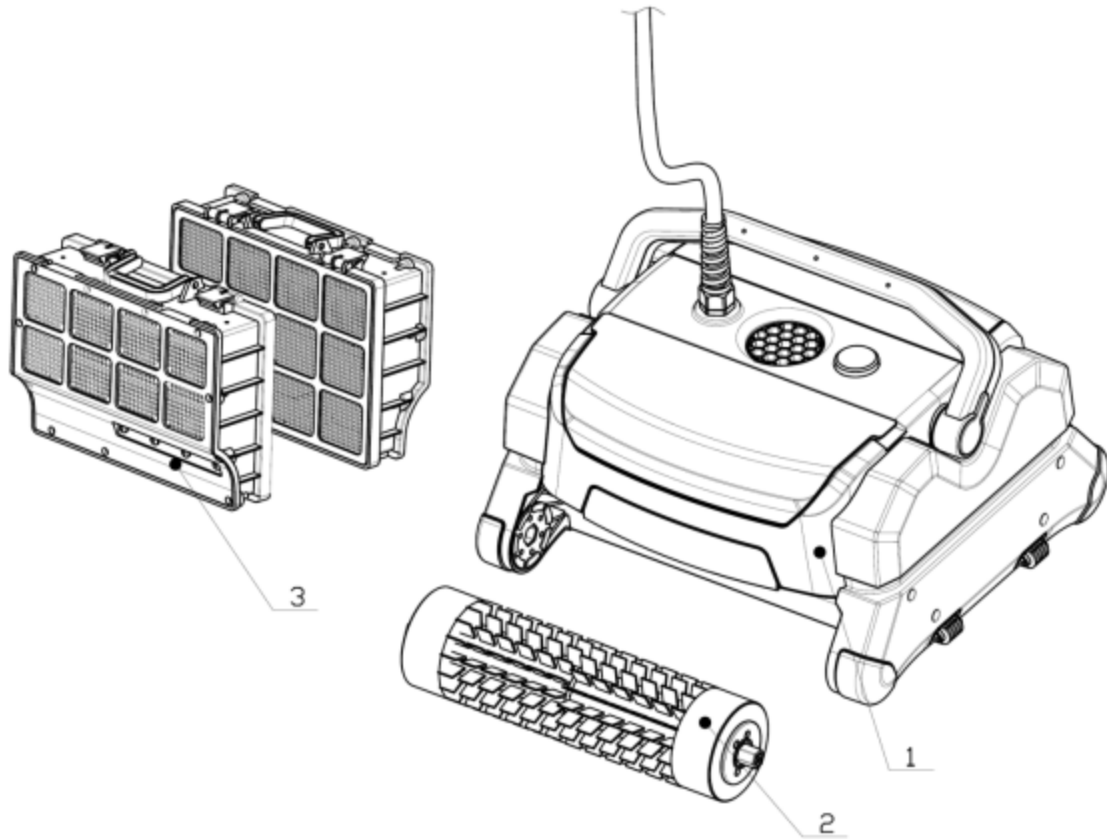

1. Main unit
2. Cleaning roller
3. Filter box

IX. Storage car (optional) usage method

1.

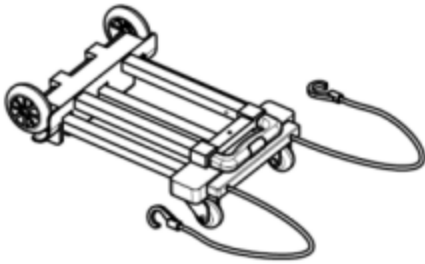

2.

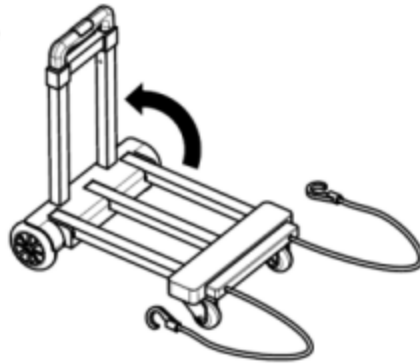

3.

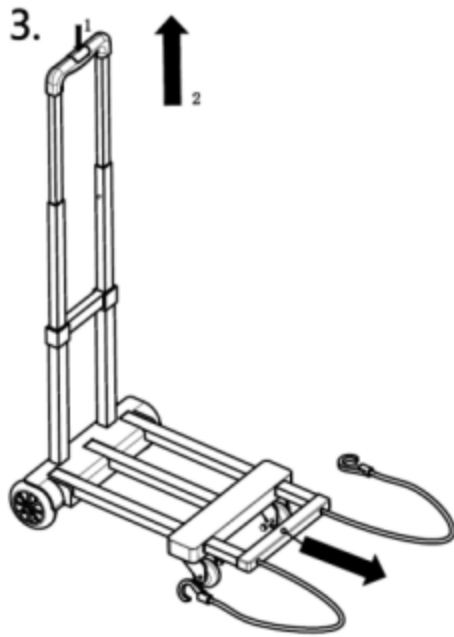

4.

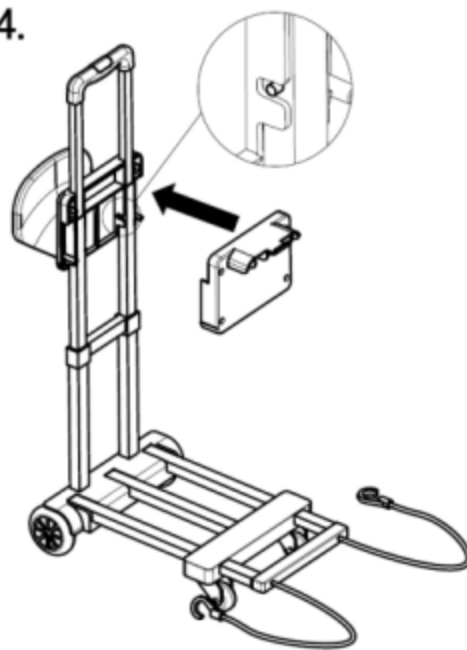

5.

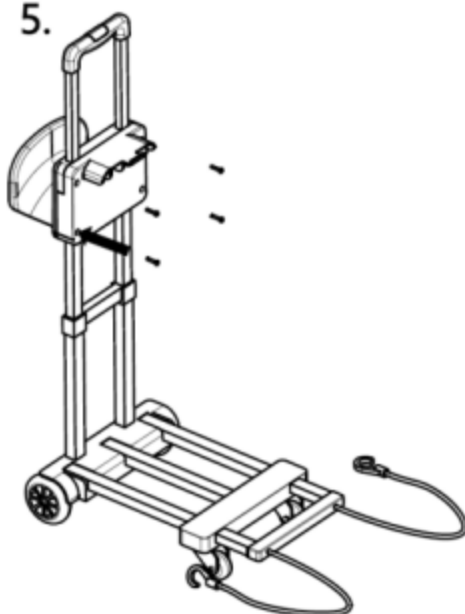

6.

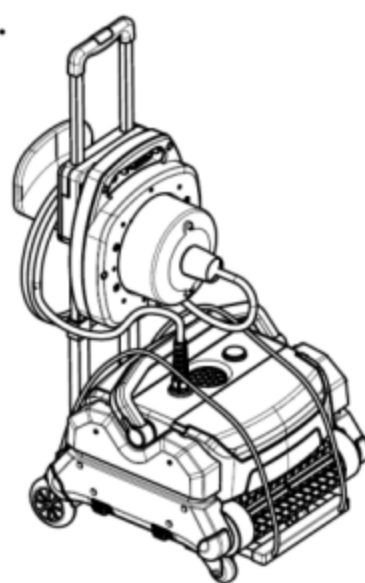

X. Aftersales Information

All products manufactured by our company are warranted against defects in manufacturing and materials for one year starting from the date of purchase.

For any warranty claim, the purchase voucher with the time of purchase indicated shall be attached. You are recommended to properly keep your invoice.

We provide limited maintenance or replacement within the warranty period, and any other expenses (such as transportation, labor, etc.) are not included in the scope of the warranty.

For damages caused by improper operation or product connection, or failure to use the original accessories within the warranty period, product maintenance and replacement are not included in the scope of the warranty.

We are not liable for any direct or indirect losses caused by improper installation.

Wearing parts (including 2. Cleaning roller, and 3. Filter box) are not included in the scope of the warranty.

This device complies with part 15 of the FCC Rules. Operation is subject to the following two conditions: (1) This device may not cause harmful interference, and (2) this device must accept any interference received, including interference that may cause undesired operation.

Any Changes or modifications not expressly approved by the party responsible for compliance could void the user's authority to operate the equipment.

Note: This equipment has been tested and found to comply with the limits for a Class B digital device, pursuant to part 15 of the FCC Rules. These limits are designed to provide reasonable protection against harmful interference in a residential installation. This equipment generates uses and can radiate radio frequency energy and, if not installed and used in accordance with the instructions, may cause harmful interference to radio communications. However, there is no guarantee that interference will not occur in a particular installation. If this equipment does cause harmful interference to radio or television reception, which can be determined by turning the equipment off and on, the user is encouraged to try to correct the interference by one or more of the following measures:

- Reorient or relocate the receiving antenna.
- Increase the separation between the equipment and receiver.
- Connect the equipment into an outlet on a circuit different from that to which the receiver is connected.
- Consult the dealer or an experienced radio/TV technician for help.

FCC Radiation Exposure statement

The device has been evaluatec to meel general RF exposure requirement. The device can be used in porlable exposure condition without restriction.