

FISCHER KEYSTONE™ 6



fischer
CONNECTORS
Part of Conexivity Group

TACTICAL HUB
USER GUIDE

FISCHER
KEYSTONE 6™



EASY CONNECTIVITY & EFFICIENT DATA & POWER MANAGEMENT FOR SOLDIER-WORN DIGITAL EQUIPMENT

- Up to 100 W of power
- USB 2.0 and SMBus data protocol
- Connects to all Nett Warrior / NATO STANAG 4695 and 4851 standard components



For full information,
please visit our website:
fischerconnectors.com



Technical specifications

CONNECTOR INTERFACE	2
ELECTRICAL	3
ENVIRONMENTAL	4
MATERIAL AND MECHANICAL	5
FIRMWARE	5
DIMENSIONS	6

Electrical architecture

VBATT POWER DISTRIBUTION	7
5 V DC POWER DISTRIBUTION	8
DATA DISTRIBUTION	9

Operating instructions

MOLLE MOUNT	10
POWERING KEYSTONE 6	11
ENABLING THE DATA FLOW	12

Keystone app instructions

LAUNCHING THE KEYSTONE APP	13
KEYSTONE APP OVERVIEW	14
PANs STATUS	15
EUD STATUS	16
BATT AND RADIO/BATT STATUS	17
MENU	19
ATAK PLUG-IN	20
LIMITATIONS OF USE	21

Technical specifications

CONNECTOR INTERFACE

Connector front view

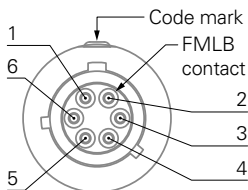

Plug

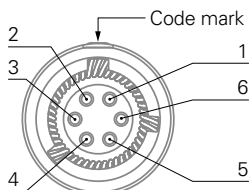

Receptacle

Pin	Power ports (plugs)	PAN/EUD ports (receptacles)
1	VBATT: [10-20] V DC 5 A max Power supply input	VBATT: [10-20] V DC 5 A max Power supply output
2	Ground	Ground
3	5 V DC IN*	5 V DC OUT**
4	USB+ / SMBus Data	USB+
5	USB- / SMBus Clock	USB-
6	NC	CC line***

*Only on RADIO/BATT port

**EUD port: INPUT/OUTPUT

***EUD port only

ELECTRICAL

EUD / HOST	VBATT output power	Unregulated VBATT [10-20] V DC, up to 5 A
	USB power	Power delivery, Charge up to 1.5 A
PAN 1/2/3	VBATT output power	Unregulated VBATT [10-20] V DC, up to 5 A
	USB output power	Regulated 5 V DC, up to 2 A per port
BATT	VBATT input power	Unregulated VBATT [10-20] V DC, up to 5 A
RADIO/BATT	VBATT input power	Unregulated VBATT [10-20] V DC, up to 5 A
	USB input power	5 V DC power supply from radio
Communication protocol	EUD, PANs	USB 2.0
	BATT, RADIO/BATT	USB 2.0 and SMBus versions 1.0/1.1 compatible
Fault mode protection	Over current, over voltage, back-power	

ENVIRONMENTAL*

Temperature	Storage	-40 °C to +55 °C
	Operating	-32 °C to +49 °C
Altitude	Storage	Up to +12,192 m
	Operating	Up to +9,754 m
	Rapid decompression	From +2,438 m to +12,192 m
Sealing	IP68 -2m/24h	
Shock	40 G, 11 ms	
Vibration	7.7 Grms, 1 h per axis	
Weather condition	Solar radiation, salt atmosphere, sand and dust, rain and water, fungus	
EMI/EMC	CE101, CE102, CS101, CS114, CS115, CS116, RE101, RE102, RS101, RS103, CS118 Level IV (ESD)	

*Validations performed per MIL-STD-810G and MIL-STD-461G

MATERIAL AND MECHANICAL

Housing material	Aluminum
Weight	241 g (8.5 oz)

FIRMWARE

Security	<ul style="list-style-type: none">▪ Only booting signed software – verified using a SHA256 checksum and an ECC256 signature▪ Software update files are encrypted using an AES 256 encryption
Certification	FIPS 140-2/3 capable

DIMENSIONS

in millimeters / in inches

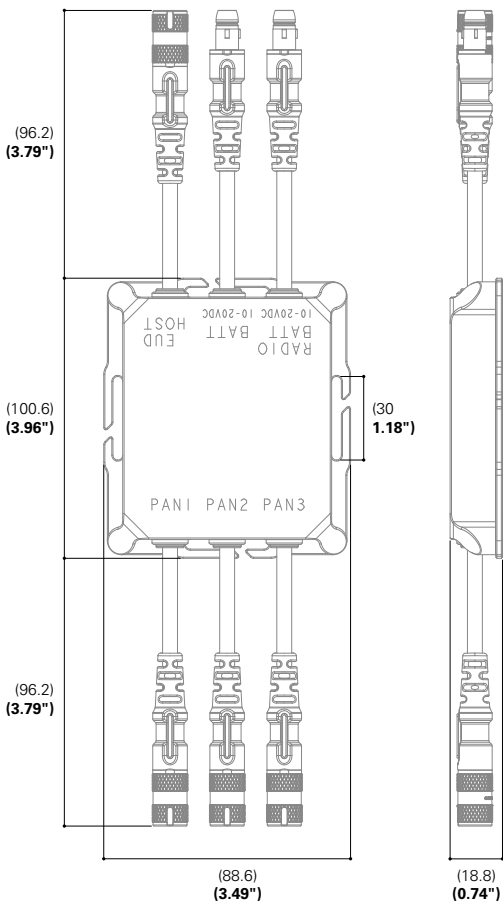

Electrical architecture

VBATT POWER DISTRIBUTION

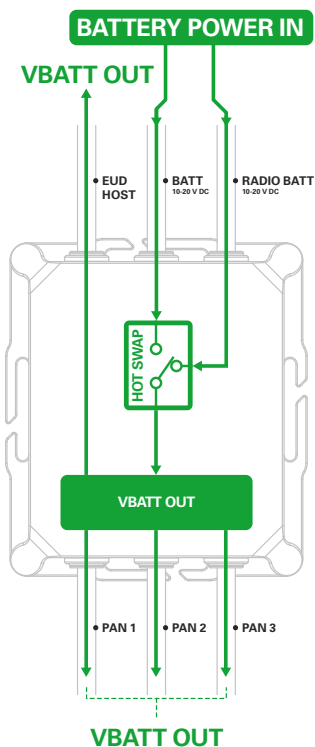

- Wide range of batteries supported, incl. SMBus protocol
- Unregulated VBATT distribution [10-20] V DC
- Dual battery hot-swap functionality
- Electrical fail-safe mechanism on all ports

5 V DC POWER DISTRIBUTION

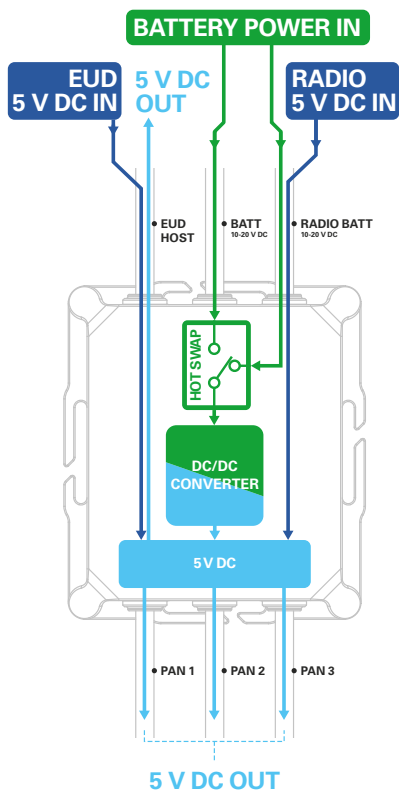

- Regulated 5 V Bus
- USB-C bidirectional power delivery on EUD port
- Radio 5 V DC power IN functionality on RADIO/BATT port

DATA DISTRIBUTION

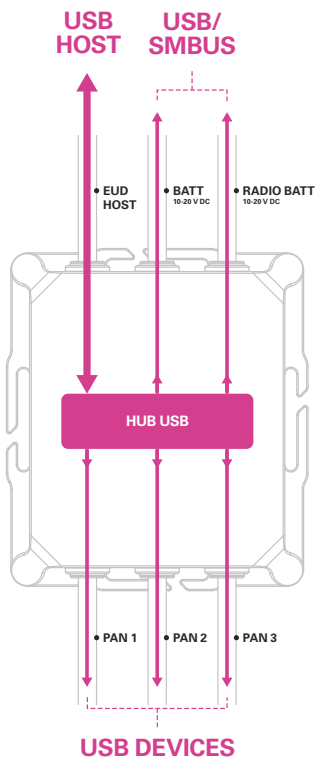

- EUD/HOST USB HUB upstream port
- PANs, BATT and RADIO/BATT USB downstream ports
- Automatic detection between USB and SMBus on BATT and RADIO/BATT ports

Operating instructions

MOLLE MOUNT



The integrated MOLLE mounts allow the KEYSTONE 6 to be attached to the soldier's vest in all four directions.

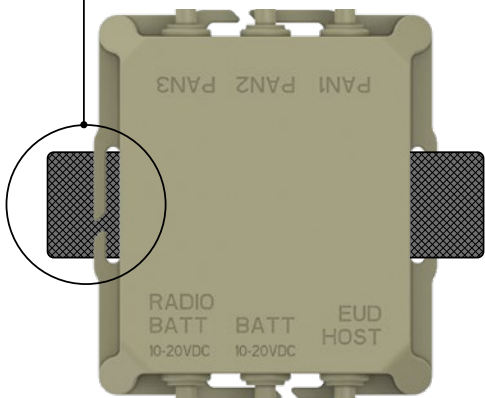

POWERING KEYSTONE 6

The KEYSTONE 6 can be powered by a 10 to 20 V DC power source on the RADIO/BATT port, the BATT port or both.

The NettWarrior extension cable can be used to connect directly to a Nett Warrior style battery or to a battery adapter.

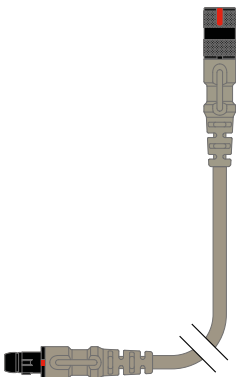
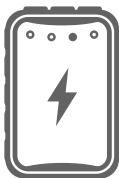
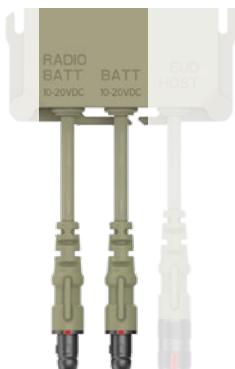

ENABLING THE DATA FLOW

To establish the data flow within the HUB, a host device must be connected to the EUD/HOST port.

Connect the End User Device (EUD) to the Fischer Nett Warrior plug to USB type C cable.

With the Fischer EUD cable, devices with an USB-C interface can leverage the KEYSTONE 6's built-in power delivery and be charged.

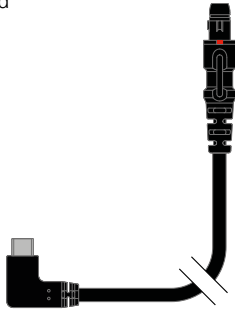

NOTE: EUD cables with integrated Power Delivery functionality are not compatible with KEYSTONE 6.

Keystone app instructions

LAUNCHING THE KEYSTONE APP

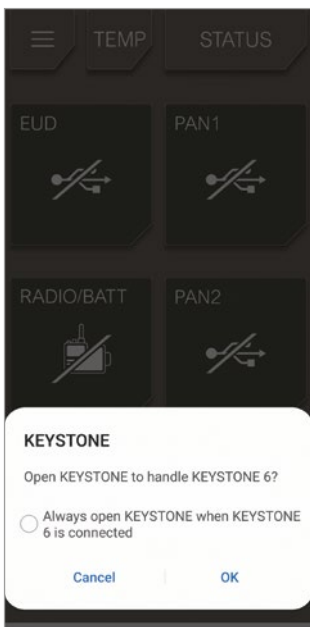

Press **OK** to enable communication between the HUB and the HOST once the EUD is connected.

KEYSTONE APP OVERVIEW

Intuitive graphic interface with all essential information directly accessible on one screen.



- Press **1** for Menu and Settings (refer to p.19)
- The icon **2** indicates the internal microcontroller temperature
- The KEystone 6 has a self-diagnosis function. The **STATUS OK** icon will change to **ALERTS** when the HUB is malfunctioning. Press the alerts icon to list the different problems.

PANs STATUS

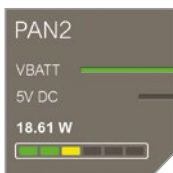

The power bar quickly indicates the amount of power consumed on the PAN. This visual indicator is completed by a measurement in Watts.

PAN output status:

- Green light means power is enabled, no light means disabled
- The visual differentiation between VBATT and 5 V DC is made by the size of the indicators

Press the PAN icon to:

- Access the output control by toggling the VBATT and 5 V DC buttons
- Display the voltage and current measurements of each output
- Modify the PAN name by clicking on the text field

NOTE: 5 V DC can be disabled without cutting data communication.

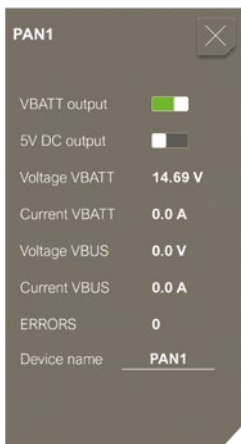

EUD STATUS

The KEYSTONE 6's built-in bidirectional power delivery function allows the EUD to be charged when the HUB is powered by an external source, typically a battery, but in the opposite case, the EUD can power the HUB with 5 V DC only.

The power meter indicates the sense of the energy flow:



EUD on charge

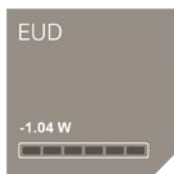

EUD providing power

Press the EUD icon to:

- Display the voltage and current measurements of the power lines
- Modify the EUD name by clicking on the text field



BATT AND RADIO/BATT STATUS

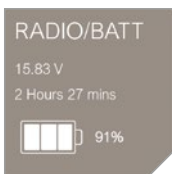

The light gray icon shows the power source in use. When it is a smart battery, in addition to the state of charge and the voltage level, the remaining operating time is displayed.

The type of battery is identified by a specific icon:

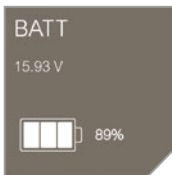

Smart battery with SMBus



Simple DC source

The following icon indicates that there is no connection to any power source on the considered port.



BATT AND RADIO/BATT STATUS

Press the BATT or RADIO/BATT icon when connected to a power source to access the following details:

The **“Set as source”** button allows the user to force the system to select a power supply.

The **USE DEFAULT SOURCE** button returns to the default selection logic:

- In case the two connected power sources are of the same nature, the RADIO/BATT port is the default power source.
- In case a smart battery and a simple DC voltage source are connected, the simple DC voltage source is the default power source.

In all cases, the hot-swap feature allows to switch from one power supply to another without any power loss.

RADIO/BATT		
Set as source	<input checked="" type="checkbox"/>	
Voltage VBATT	15.69 V	
Current VBATT	1.032 A	
SOC	89 %	
Remaining	2H 13m	
Alert threshold	10 %	
ERRORS	0	
Device name	RADIO/BATT	
<input type="button" value="USE DEFAULT SOURCE"/>		

An alert threshold can be defined according to the battery charge level. The threshold is defined as follows:

- in % for smart batteries
- in Volts for DC sources

Once reached, the battery icon turns into orange.



MENU

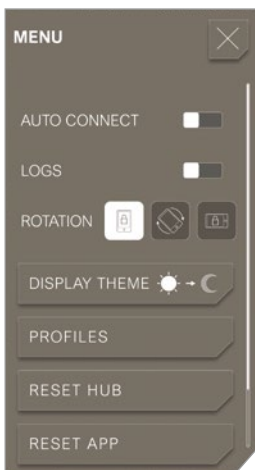

The activation of the logs allows to record all the parameters of energy consumption for post mission analysis.

“AUTO CONNECT” will automatically enable the communication with the HUB at connection without asking the user to confirm.

A night mode is available by pressing the **DISPLAY THEME** button.

When **creating a profile**, all current settings are saved and are associated with the newly created profile which automatically becomes the default profile.

Resetting the HUB will reboot the HUB, therefore data and power will be lost during the reboot cycle.

Resetting the KEYSTONE app will reset the HUB and return the system to initial factory settings. All profiles will be lost.



ATAK PLUG-IN

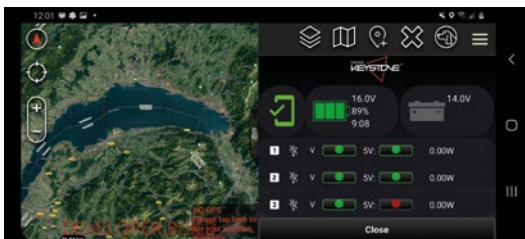

The KEYSTONE 6 can also be controlled through a plug-in in ATAK.

In ATAK the features have been reduced to the essential:

- Power management of the PANs
- Hot-swap function

LIMITATIONS OF USE

1. This product and its accessories must be used for its intended purpose only. Failing to do so (or failing to comply) will void the warranty.
2. Do not use in an explosive atmosphere.
3. Unused (or unmated) pigtailed should be fastened to the vest and should not be left loose.
4. Fischer Connectors SA is not responsible for any changes or modifications not expressly approved by Fischer Connectors SA for compliance. Such modifications could void the user's authority to operate the equipment.

This device complies with part 15 of the FCC Rules. Operation is subject to the following two conditions:

(1) This device may not cause harmful interference, and
(2) this device must accept any interference received, including interference that may cause undesired operation.

FCC ID: 2BBS9-HBK06

NOTE: This equipment has been tested and found to comply with the limits for a Class A digital device, pursuant to part 15 of the FCC Rules. These limits are designed to provide reasonable protection against harmful interference when the equipment is operated in a commercial environment.

This equipment generates, uses, and can radiate radio frequency energy and, if not installed and used in accordance with the instruction manual, may cause harmful interference to radio communications. Operation of this equipment in a residential area is likely to cause harmful interference in which case the user will be required to correct the interference at his own expense.

NOTES



Explore high-performance
connectivity solutions
[fischerconnectors.com](https://www.fischerconnectors.com)

—
© Fischer Connectors SA – All rights reserved
550312 – Version 1.3 – 08.2023
Changes without prior notice