

GSM1900

MEASUREMENT 1

High Band SAR (Channel 810):

Date: 09/07/2023

| | |
|-----------------------------------------------|-------------------------------------------------------------------|
| Frequency (MHz) | 1909.800000 |
| Relative permittivity (real part) | 40.000000 |
| Relative permittivity (imaginary part) | 13.408000 |
| Conductivity (S/m) | 1.400391 |
| Variation (%) | -3.790000 |
| Crest Factor | 1.0 |
| Probe Conversion factor | 2.23 |
| E-Field Probe: | SSE2 (SN 25/22 EPG0375) |
| Area Scan | dx=8mm dy=8mm, h= 5.00 mm |
| ZoomScan | 5x5x7,dx=8mm dy=8mm dz=5mm,Complete/ndx=8mm dy=8mm, h= 5.00 mm |
| Phantom | Validation plane |
| Device Position | Body back(0mm) |
| Band | GSM1900(GPRS 3slot) |

SURFACE SAR

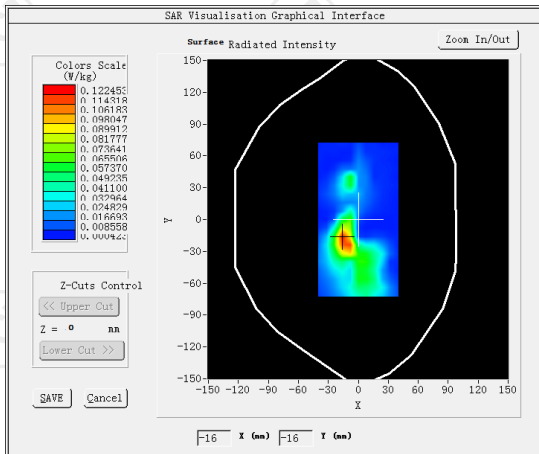

VOLUME SAR

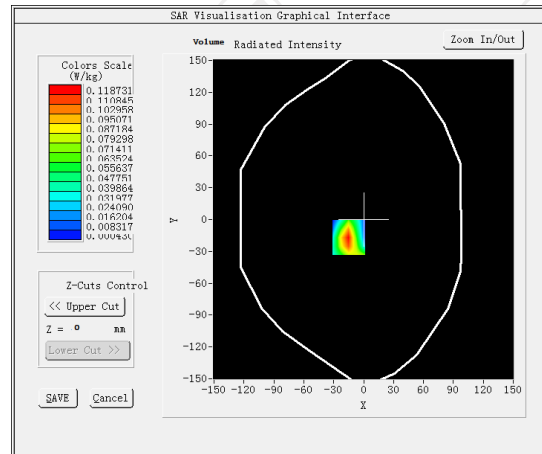

Maximum location: X=-15.00, Y=-17.00 SAR Peak:1.79 W/kg

SAR 10g (W/Kg)

0.464003

SAR 1g (W/Kg)

0.345943

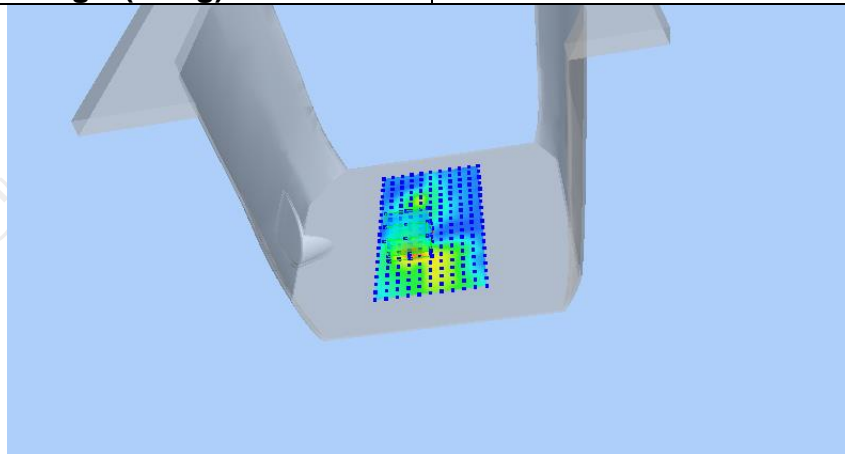

| | | | | | |
|-------------------|---------------|---------------|---------------|---------------|---------------|
| Z (mm) | 0.00 | 4.00 | 9.00 | 14.00 | 19.00 |
| SAR (W/Kg) | 1.7918 | 1.0248 | 0.4870 | 0.2387 | 0.1364 |

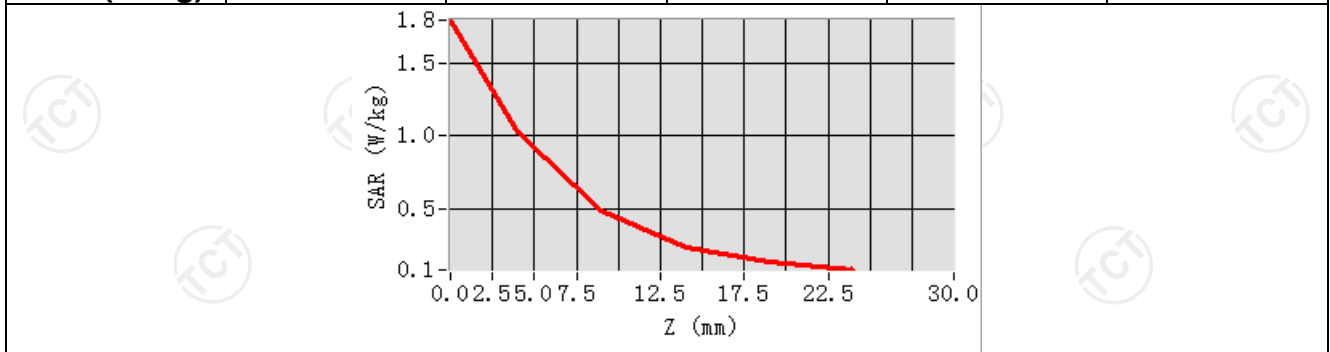

Hot spot position

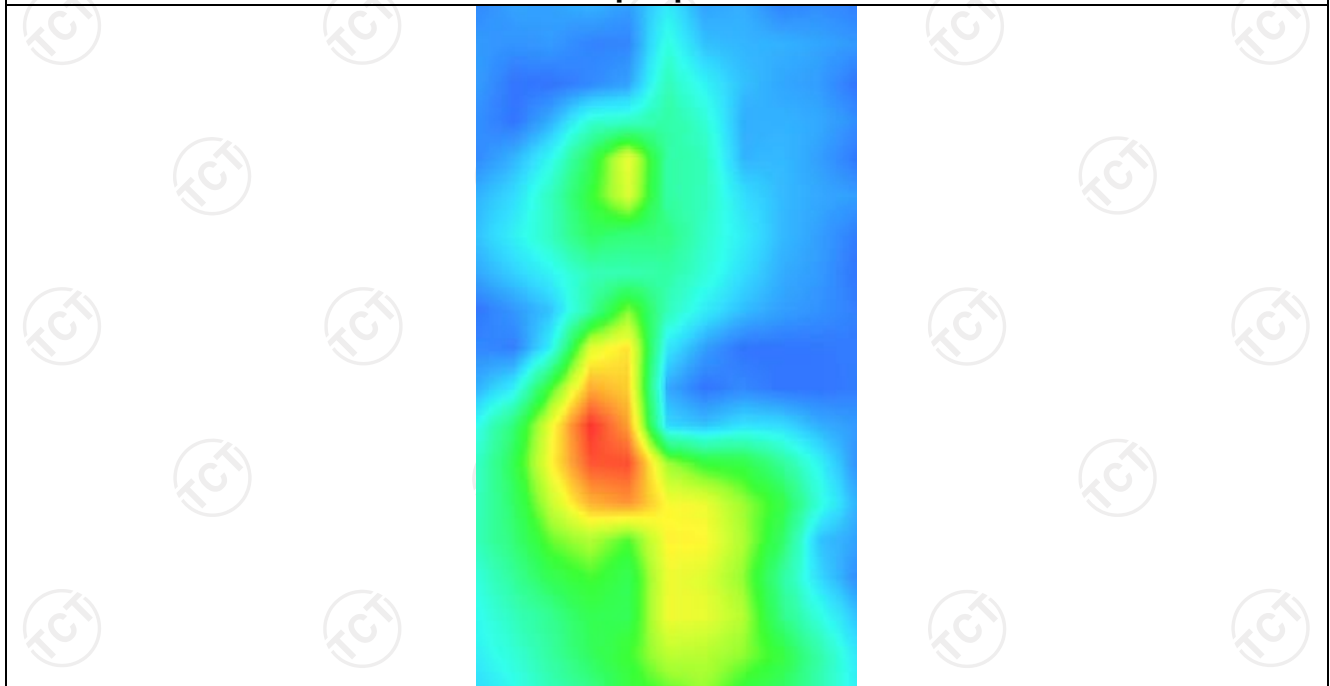

MEASUREMENT 2

High Band SAR (Channel 810):

Date: 09/07/2023

| | |
|-----------------------------------------------|---------------------------------------------------------------------------------------------|
| Frequency (MHz) | 1909.800000 |
| Relative permittivity (real part) | 40.000000 |
| Relative permittivity (imaginary part) | 13.408000 |
| Conductivity (S/m) | 1.400391 |
| Variation (%) | 4.280000 |
| Crest Factor | 1.0 |
| Probe Conversion factor | 2.23 |
| E-Field Probe: | SSE2 (SN 25/22 EPG0375) |
| Area Scan | <u>dx=8mm dy=8mm, h= 5.00 mm</u> |
| ZoomScan | <u>5x5x7, dx=8mm dy=8mm</u> <u>dz=5mm, Complete/ndx=8mm dy=8mm, h=</u> <u>5.00 mm</u> |
| Phantom | <u>Validation plane</u> |
| Device Position | <u>Body back(0mm)</u> |
| Band | <u>GSM1900(GPRS 4slot hotspot)</u> |

SURFACE SAR

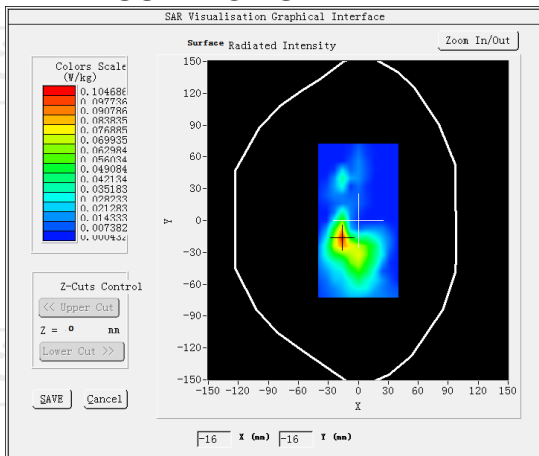

VOLUME SAR

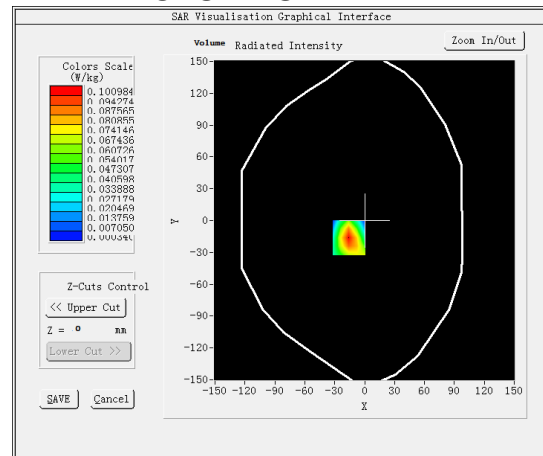

Maximum location: X=-16.00, Y=-16.00 SAR Peak: 1.89 W/kg

SAR 10g (W/Kg)

0.505055

SAR 1g (W/Kg)

0.617390

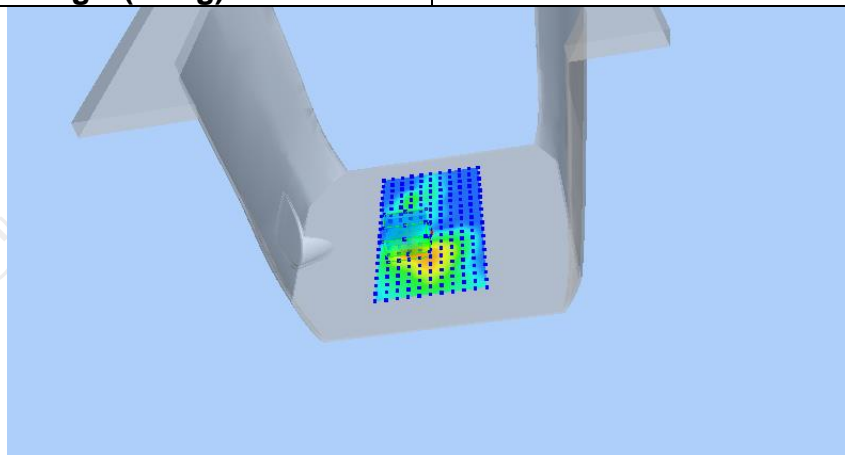

| | | | | | |
|------------|--------|--------|--------|--------|--------|
| Z (mm) | 0.00 | 4.00 | 9.00 | 14.00 | 19.00 |
| SAR (W/Kg) | 1.8913 | 1.0978 | 0.5344 | 0.2689 | 0.1563 |

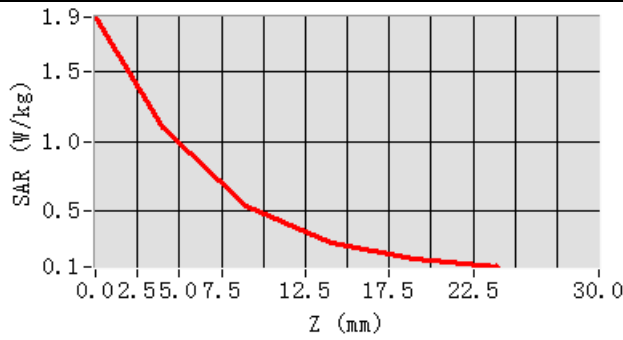

Hot spot position

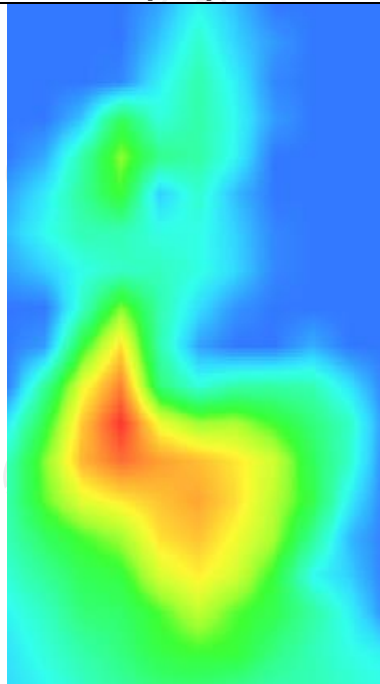

WCDMA Band II
MEASUREMENT 1

Middle Band SAR (Channel 9400):

Date: 09/07/2023

| | |
|-----------------------------------------------|---------------------------------------------------------------------------------------------|
| Frequency (MHz) | 1880.000000 |
| Relative permittivity (real part) | 40.000000 |
| Relative permittivity (imaginary part) | 13.408000 |
| Conductivity (S/m) | 1.400391 |
| Variation (%) | -4.540000 |
| Crest Factor | 1.0 |
| Probe Conversion factor | 2.23 |
| E-Field Probe: | SSE2 (SN 25/22 EPGO375) |
| Area Scan | <u>dx=8mm dy=8mm, h= 5.00 mm</u> |
| ZoomScan | <u>5x5x7, dx=8mm dy=8mm</u> <u>dz=5mm, Complete/ndx=8mm dy=8mm, h=</u> <u>5.00 mm</u> |
| Phantom | <u>Validation plane</u> |
| Device Position | <u>Body back(0mm)</u> |
| Band | <u>BAND2 WCDMA1900</u> |

SURFACE SAR

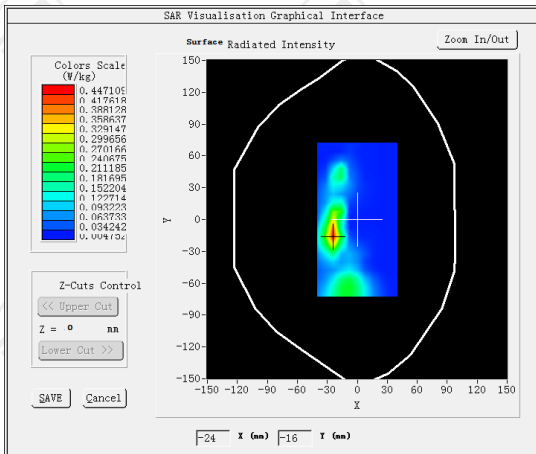

VOLUME SAR

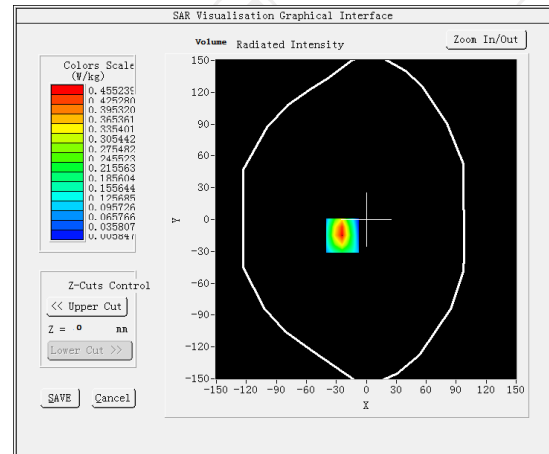

Maximum location: X=-24.00, Y=-15.00 SAR Peak: 0.88 W/kg

SAR 10g (W/Kg)

0.183081

SAR 1g (W/Kg)

0.425712

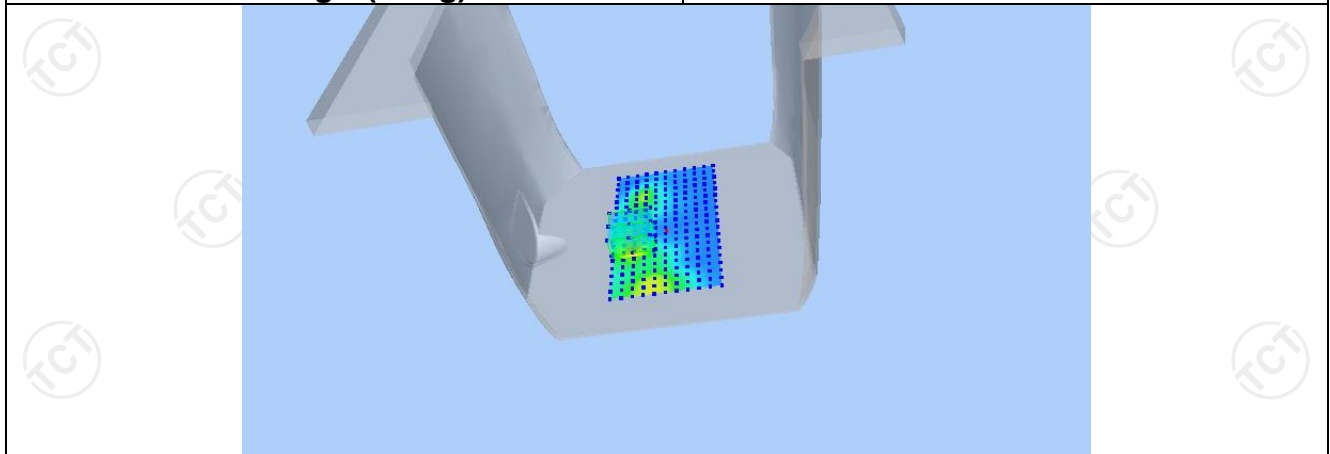

| | | | | | |
|------------|--------|--------|--------|--------|--------|
| Z (mm) | 0.00 | 4.00 | 9.00 | 14.00 | 19.00 |
| SAR (W/Kg) | 0.8677 | 0.4552 | 0.1835 | 0.0703 | 0.0300 |

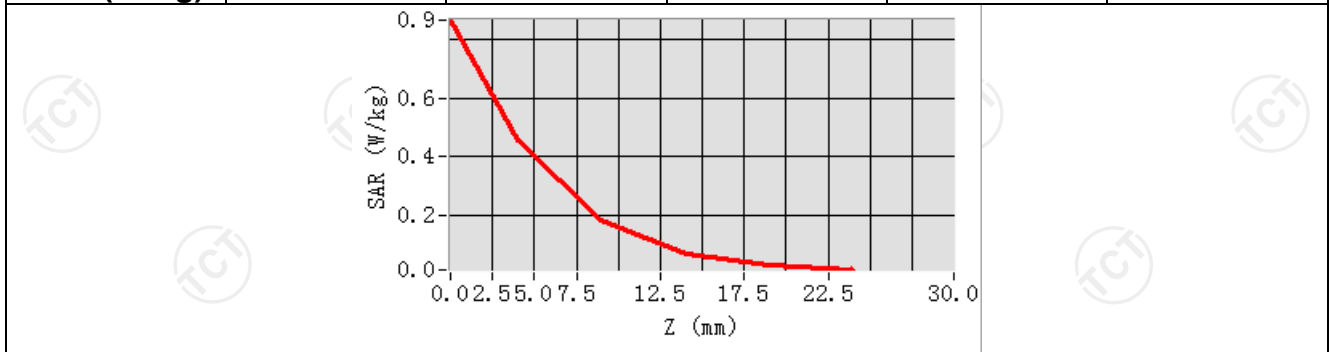

Hot spot position

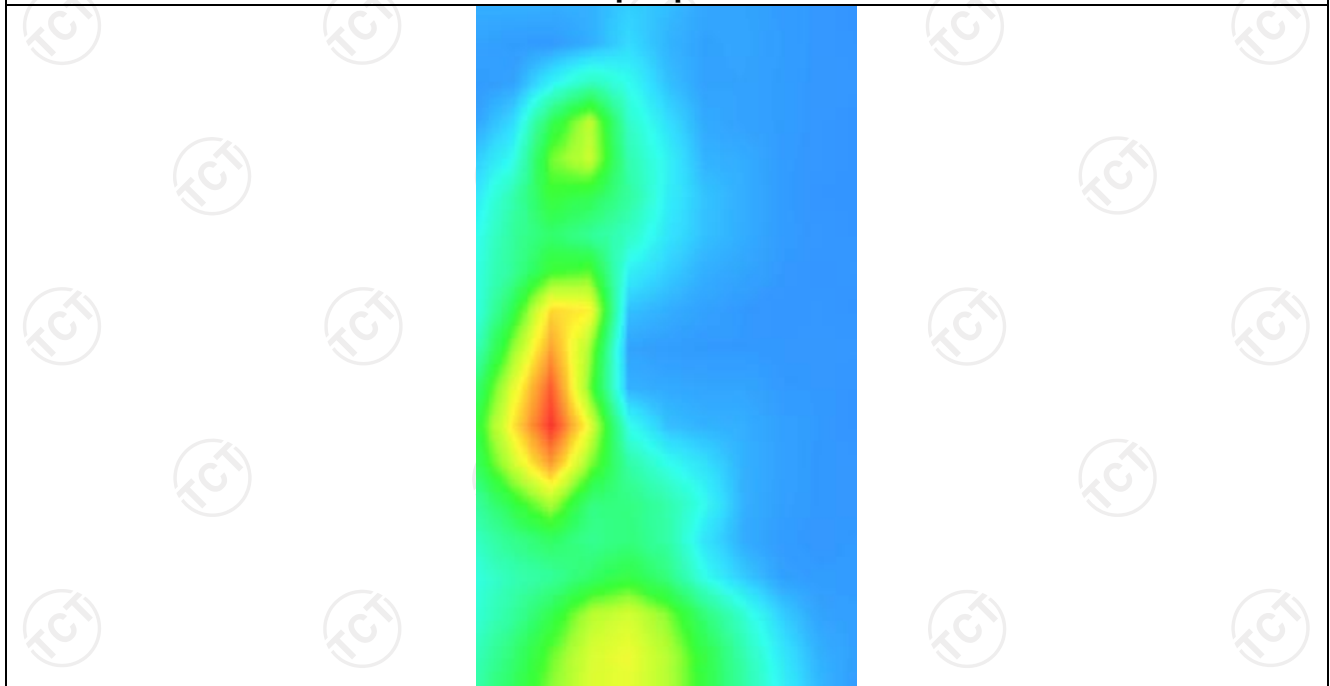

MEASUREMENT 2

Middle Band SAR (Channel 9400):

Date: 09/07/2023

| | |
|-----------------------------------------------|-----------------------------------------------------------------------|
| Frequency (MHz) | 1880.000000 |
| Relative permittivity (real part) | 40.000000 |
| Relative permittivity (imaginary part) | 13.408000 |
| Conductivity (S/m) | 1.400391 |
| Variation (%) | -4.910000 |
| Crest Factor | 1.0 |
| Probe Conversion factor | 2.23 |
| E-Field Probe: | SSE2 (SN 25/22 EPGO375) |
| Area Scan | <u>dx=8mm dy=8mm, h= 5.00 mm</u> |
| ZoomScan | <u>5x5x7,dx=8mm dy=8mm dz=5mm,Complete/ndx=8mm dy=8mm, h= 5.00 mm</u> |
| Phantom | <u>Validation plane</u> |
| Device Position | <u>Body back(0mm)</u> |
| Band | <u>BAND2 WCDMA1900(hotspot)</u> |

SURFACE SAR

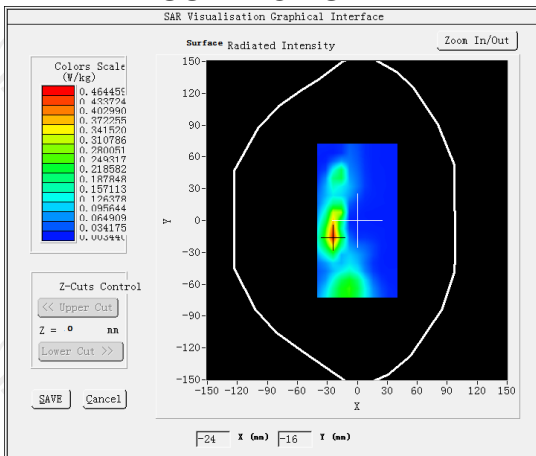

VOLUME SAR

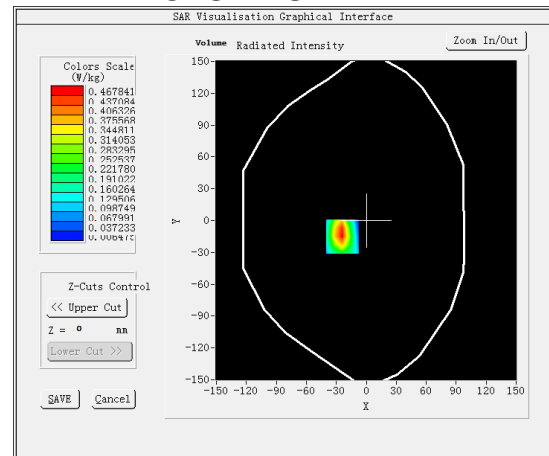

Maximum location: X=-24.00, Y=-15.00 SAR Peak: 0.89 W/kg

SAR 10g (W/Kg)

0.198629

SAR 1g (W/Kg)

0.440246

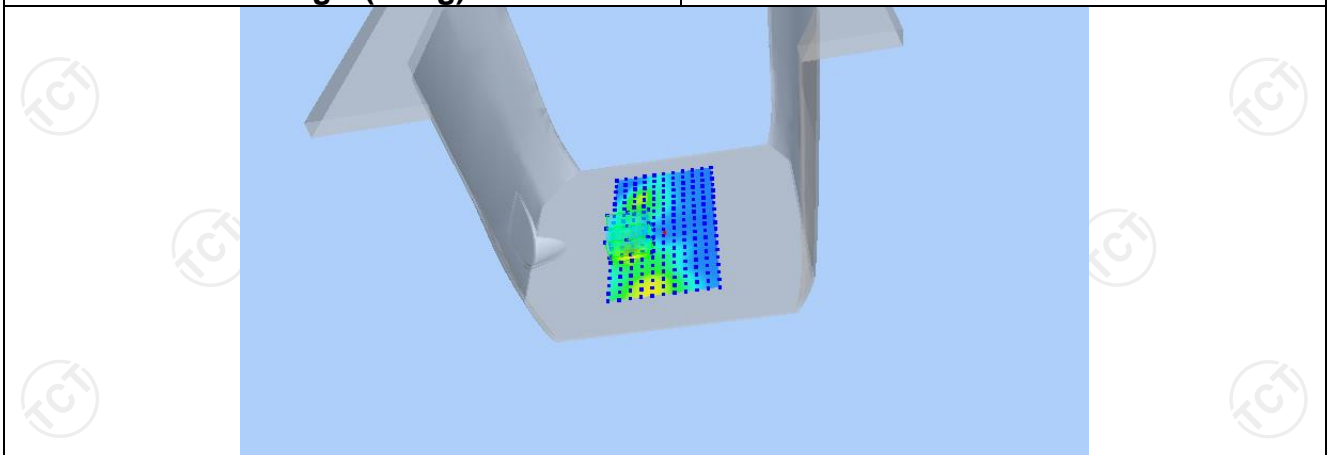

| | | | | | |
|------------|--------|--------|--------|--------|--------|
| Z (mm) | 0.00 | 4.00 | 9.00 | 14.00 | 19.00 |
| SAR (W/Kg) | 0.8766 | 0.4678 | 0.1971 | 0.0835 | 0.0427 |

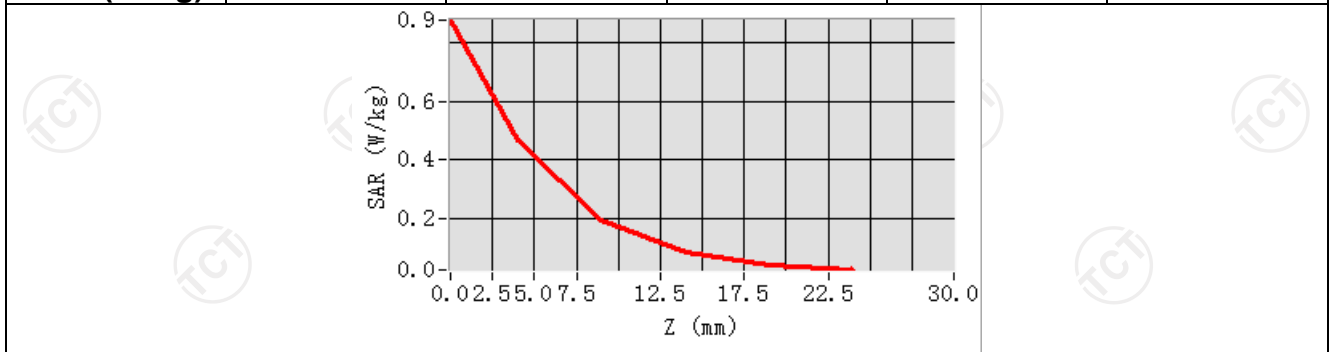

Hot spot position

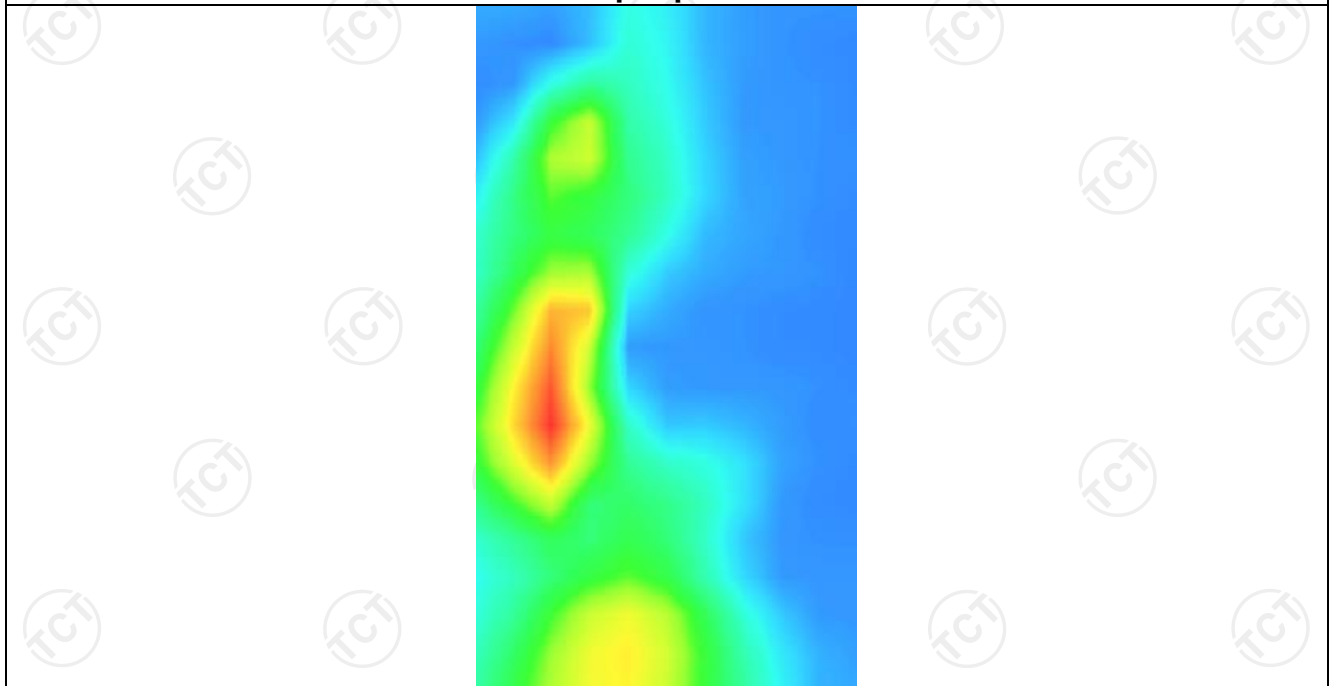

WCDMA Band IV
MEASUREMENT 1

High Band SAR (Channel 1513): Date: 09/06/2023

| | |
|-----------------------------------------------|---------------------------------------------------------------------------------------------|
| Frequency (MHz) | 1752.600000 |
| Relative permittivity (real part) | 40.116364 |
| Relative permittivity (imaginary part) | 14.137455 |
| Conductivity (S/m) | 1.360337 |
| Variation (%) | 1.970000 |
| Crest Factor | 1.0 |
| Probe Conversion factor | 2.08 |
| E-Field Probe: | SSE2 (SN 25/22 EPGO375) |
| Area Scan | <u>dx=8mm dy=8mm, h= 5.00 mm</u> |
| ZoomScan | <u>5x5x7, dx=8mm dy=8mm</u> <u>dz=5mm, Complete/ndx=8mm dy=8mm, h=</u> <u>5.00 mm</u> |
| Phantom | <u>Validation plane</u> |
| Device Position | <u>Body back(0mm)</u> |
| Band | <u>BAND4 WCDMA1700</u> |

SURFACE SAR

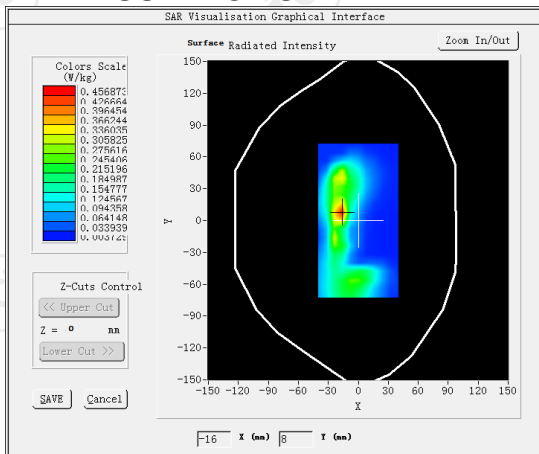

VOLUME SAR

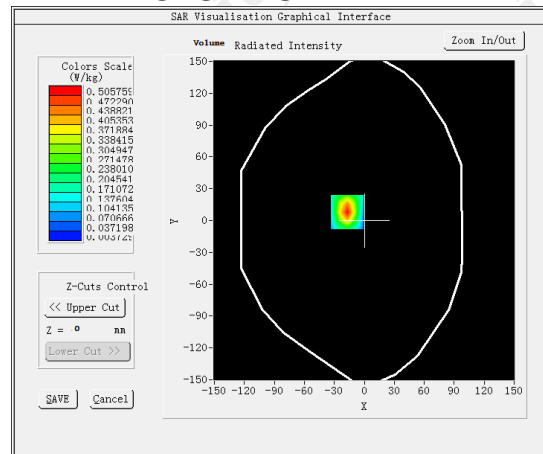

Maximum location: X=-17.00, Y=8.00 SAR Peak:1.10 W/kg

SAR 10g (W/Kg)

0.196697

SAR 1g (W/Kg)

0.475371

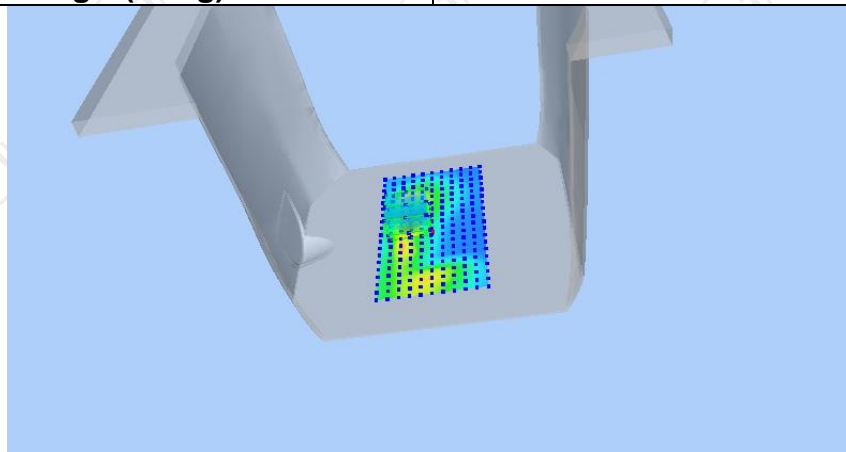

| | | | | | |
|-------------------|---------------|---------------|---------------|---------------|---------------|
| Z (mm) | 0.00 | 4.00 | 9.00 | 14.00 | 19.00 |
| SAR (W/Kg) | 1.1085 | 0.5058 | 0.1563 | 0.0429 | 0.0165 |

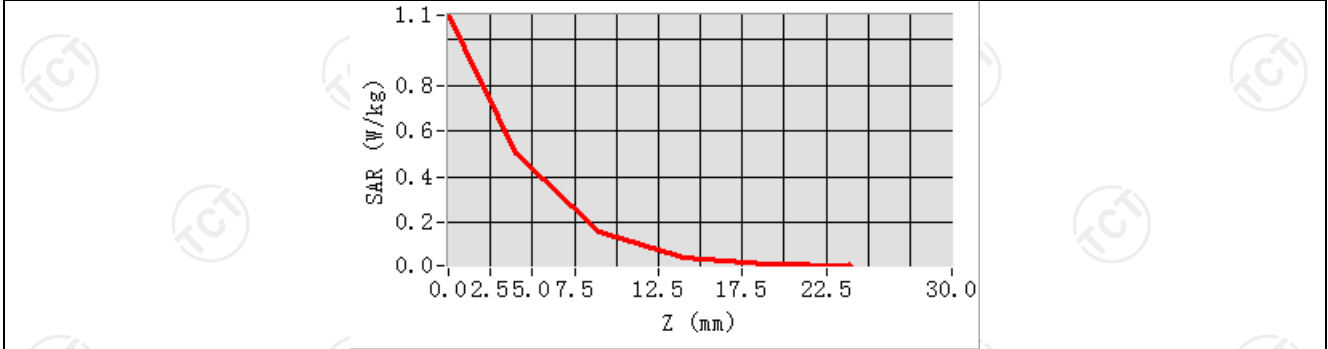

Hot spot position

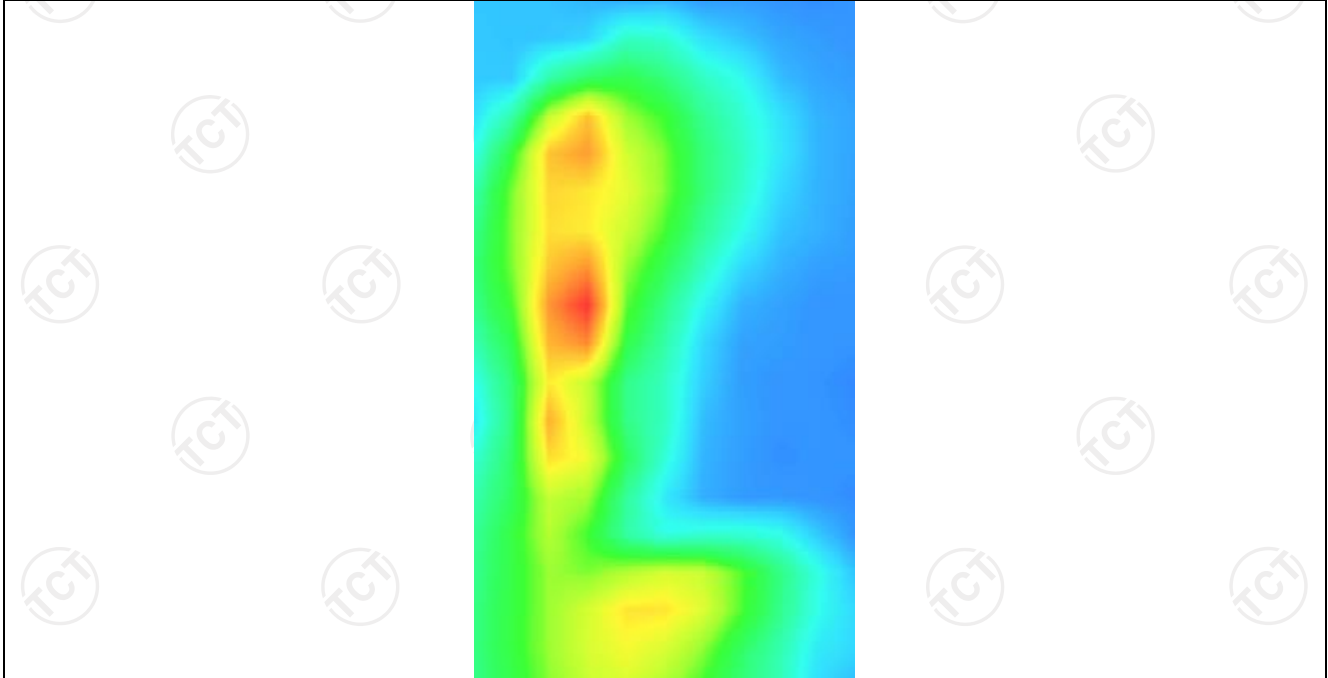

MEASUREMENT 2

High Band SAR (Channel 1513):

Date: 09/06/2023

| | |
|-----------------------------------------------|-------------------------------------------------------------------------------------------|
| Frequency (MHz) | 1752.600000 |
| Relative permittivity (real part) | 40.116364 |
| Relative permittivity (imaginary part) | 14.137455 |
| Conductivity (S/m) | 1.360337 |
| Variation (%) | -2.250000 |
| Crest Factor | 1.0 |
| Probe Conversion factor | 2.08 |
| E-Field Probe: | SSE2 (SN 25/22 EPG0375) |
| Area Scan | <u>dx=8mm dy=8mm, h= 5.00 mm</u> |
| ZoomScan | <u>5x5x7,dx=8mm dy=8mm</u> <u>dz=5mm,Complete/ndx=8mm dy=8mm, h=</u> <u>5.00 mm</u> |
| Phantom | <u>Validation plane</u> |
| Device Position | <u>Body back(hotspot 0mm)</u> |
| Band | <u>BAND4 WCDMA1700</u> |

SURFACE SAR

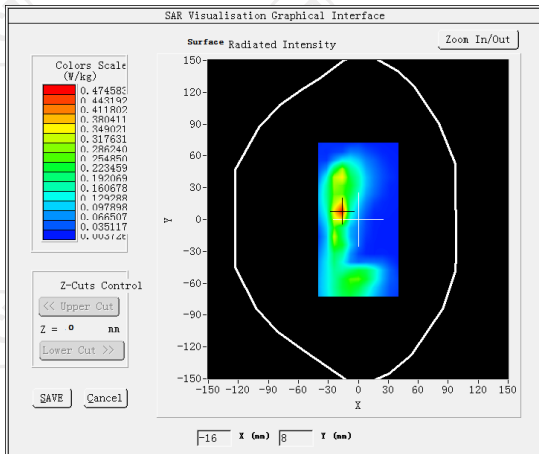

VOLUME SAR

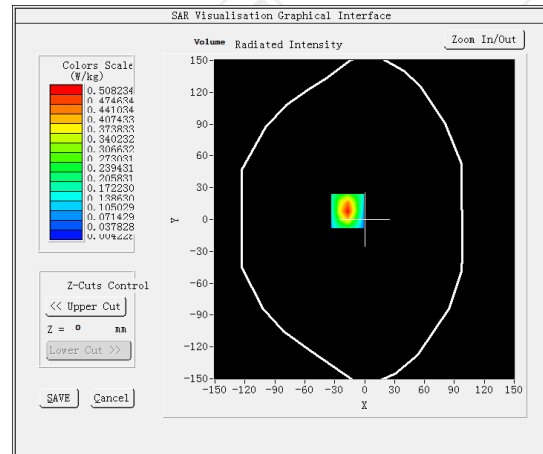

Maximum location: X=-17.00, Y=8.00 SAR Peak: 1.10 W/kg

SAR 10g (W/Kg)

0.198463

SAR 1g (W/Kg)

0.477553

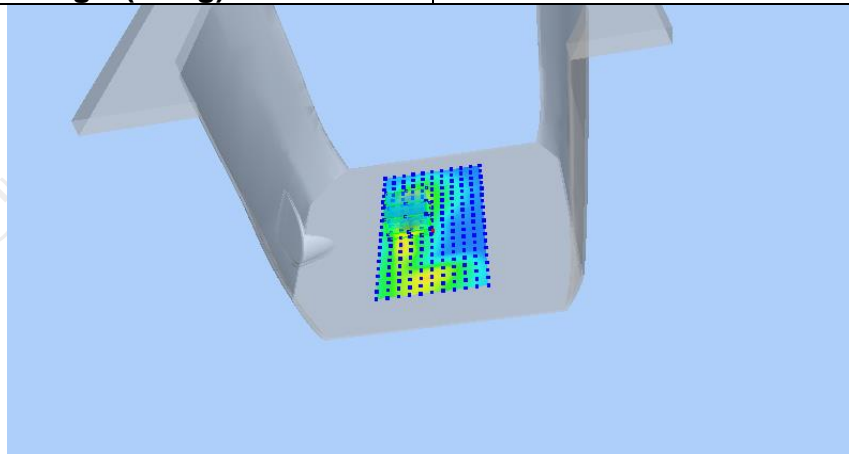

| | | | | | |
|------------|--------|--------|--------|--------|--------|
| Z (mm) | 0.00 | 4.00 | 9.00 | 14.00 | 19.00 |
| SAR (W/Kg) | 1.1034 | 0.5082 | 0.1600 | 0.0448 | 0.0169 |

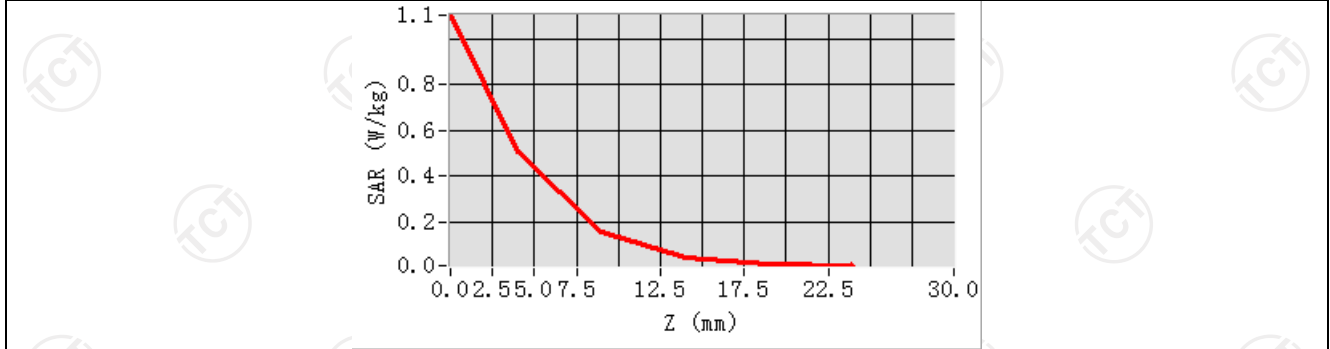

Hot spot position

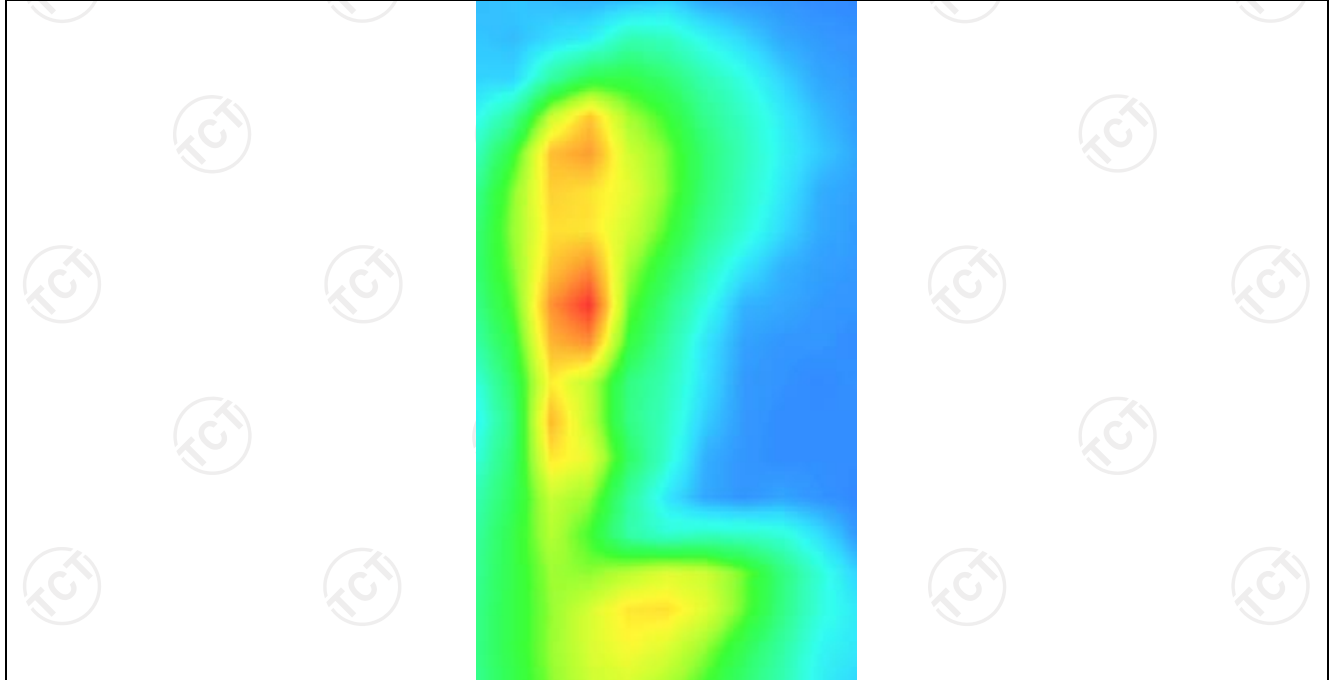

WCDMA Band V
MEASUREMENT 1

Middle Band SAR (Channel 4182):

Date: 09/05/2023

| | |
|-----------------------------------------------|---------------------------------------------------------------------------------------------|
| Frequency (MHz) | 836.400000 |
| Relative permittivity (real part) | 41.500000 |
| Relative permittivity (imaginary part) | 19.400000 |
| Conductivity (S/m) | 0.901453 |
| Variation (%) | 1.580000 |
| Crest Factor: | 1.0 |
| Probe Conversion factor | 1.80 |
| E-Field Probe: | SSE2 (SN 25/22 EPGO375) |
| Area Scan | <u>dx=8mm dy=8mm, h= 5.00 mm</u> |
| ZoomScan | <u>5x5x7, dx=8mm dy=8mm</u> <u>dz=5mm, Complete/ndx=8mm dy=8mm, h=</u> <u>5.00 mm</u> |
| Phantom | <u>Validation plane</u> |
| Device Position | <u>Body back(0mm)</u> |
| Band | <u>BAND5 WCDMA850</u> |

SURFACE SAR

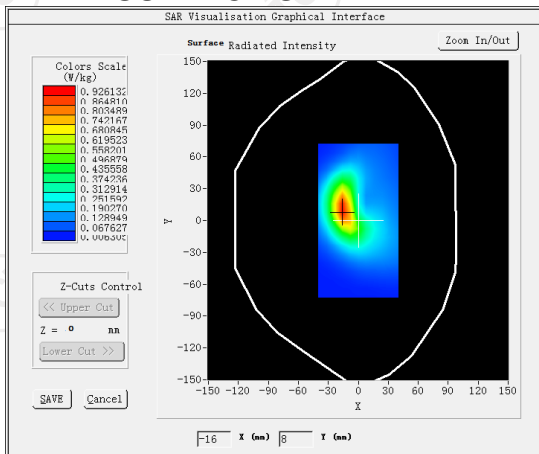

VOLUME SAR

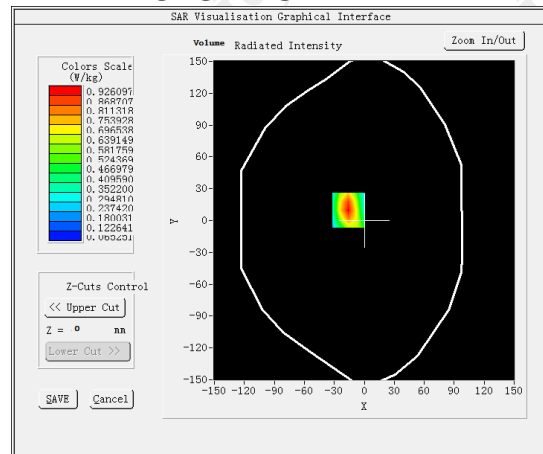

Maximum location: X=-16.00, Y=10.00 SAR Peak: 1.41 W/kg

SAR 10g (W/Kg)

0.180112

SAR 1g (W/Kg)

0.235203

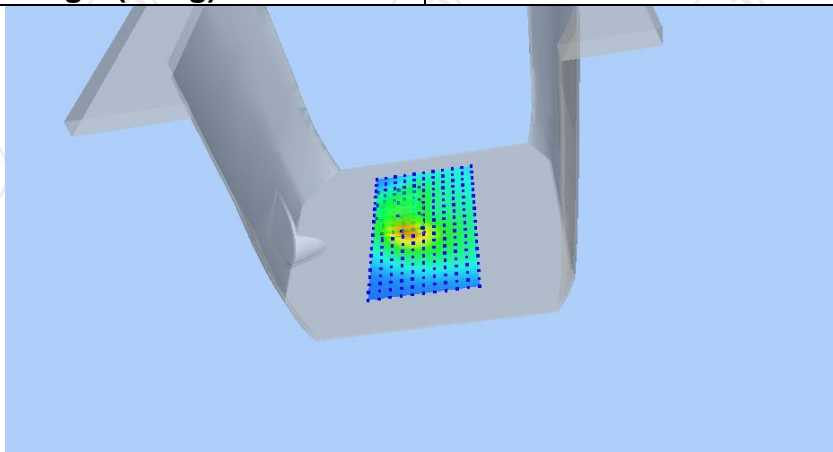

| | | | | | |
|-------------------|---------------|---------------|---------------|---------------|---------------|
| Z (mm) | 0.00 | 4.00 | 9.00 | 14.00 | 19.00 |
| SAR (W/Kg) | 1.4114 | 0.9261 | 0.5406 | 0.3244 | 0.2084 |

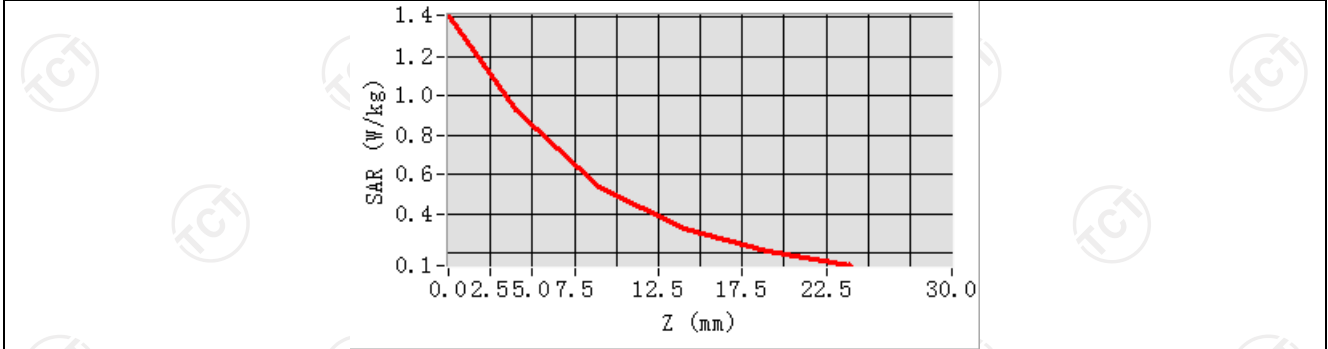

Hot spot position

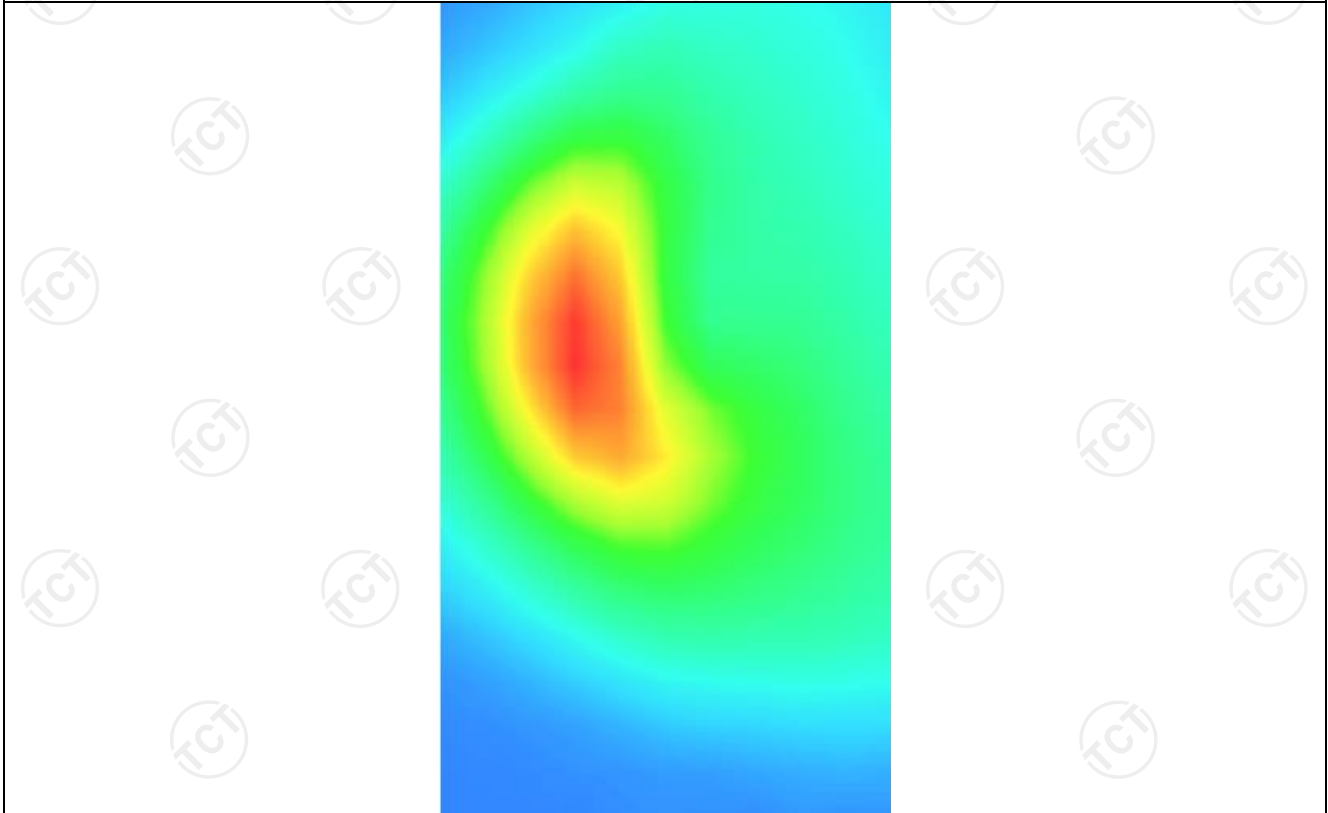

MEASUREMENT 2

Middle Band SAR (Channel 4182):

Date: 09/05/2023

| | |
|-----------------------------------------------|-------------------------------------------------------------------------------------------|
| Frequency (MHz) | 836.400000 |
| Relative permittivity (real part) | 41.500000 |
| Relative permittivity (imaginary part) | 19.400000 |
| Conductivity (S/m) | 0.901453 |
| Variation (%) | -0.180000 |
| Crest Factor: | 1.0 |
| Probe Conversion factor | 1.80 |
| E-Field Probe: | SSE2 (SN 25/22 EPGO375) |
| Area Scan | <u>dx=8mm dy=8mm, h= 5.00 mm</u> |
| ZoomScan | <u>5x5x7,dx=8mm dy=8mm</u> <u>dz=5mm,Complete/ndx=8mm dy=8mm, h=</u> <u>5.00 mm</u> |
| Phantom | <u>Validation plane</u> |
| Device Position | <u>Body back(0mm)</u> |
| Band | <u>BAND5 WCDMA850(hotspot)</u> |

SURFACE SAR

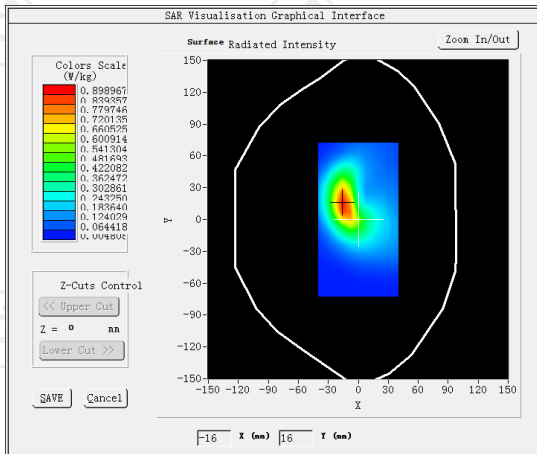

VOLUME SAR

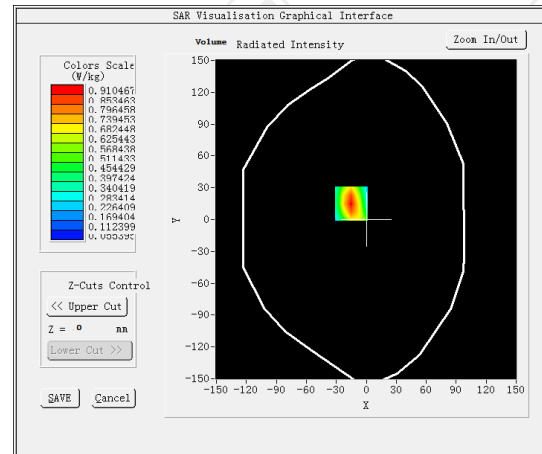

Maximum location: X=-15.00, Y=15.00 SAR Peak:1.39 W/kg

SAR 10g (W/Kg)

0.471846

SAR 1g (W/Kg)

0.241492

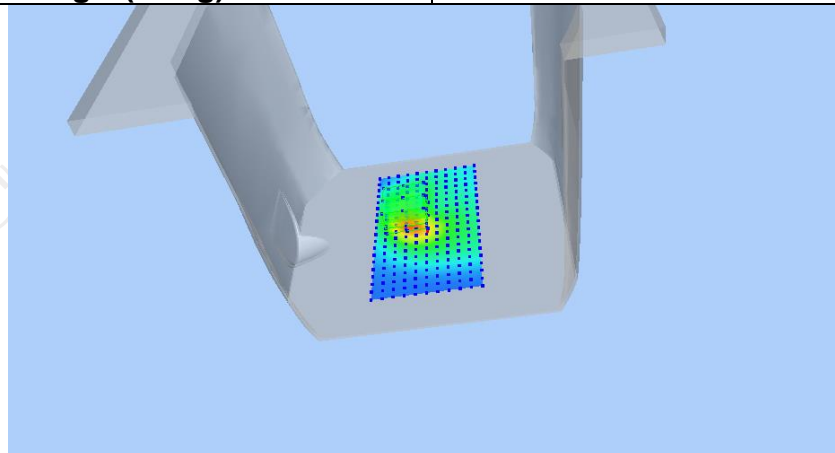

| | | | | | |
|------------|--------|--------|--------|--------|--------|
| Z (mm) | 0.00 | 4.00 | 9.00 | 14.00 | 19.00 |
| SAR (W/Kg) | 1.3872 | 0.9105 | 0.5317 | 0.3192 | 0.2052 |

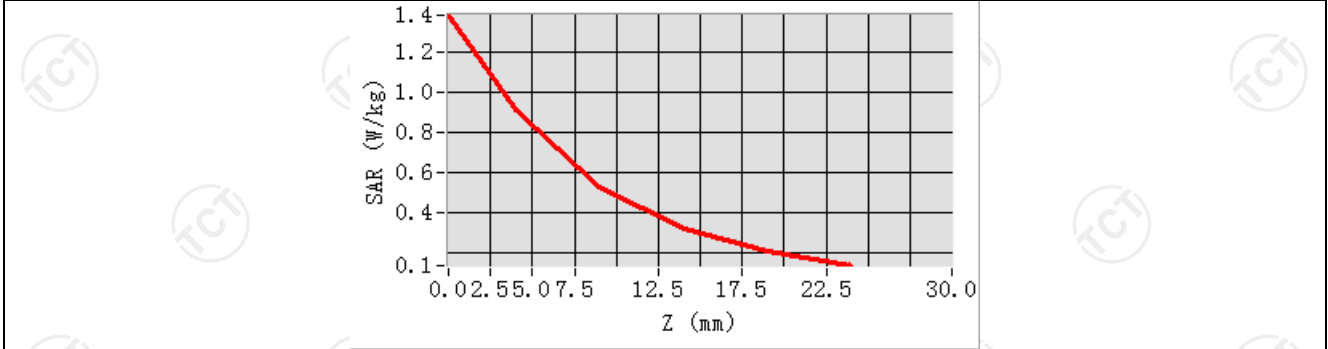

Hot spot position

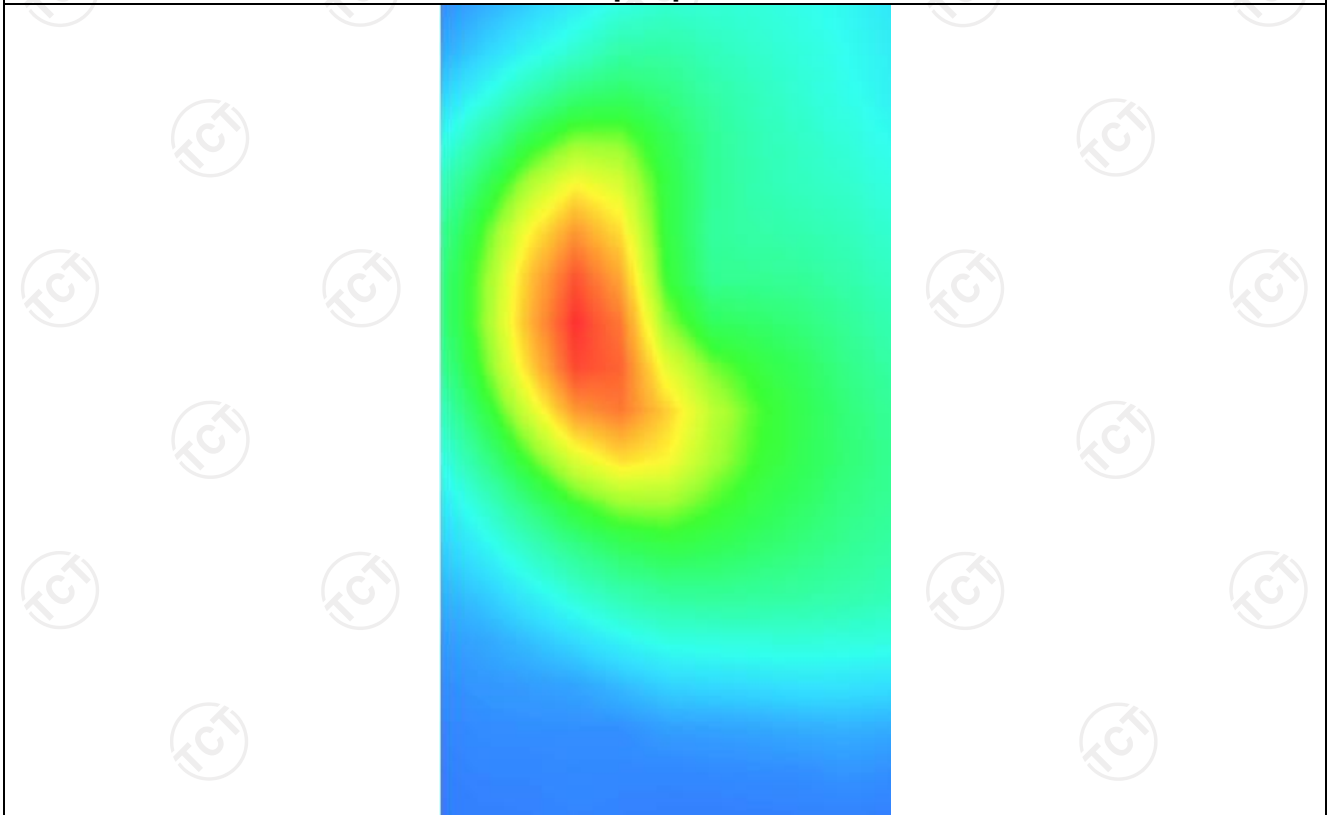

LTE Band 2

MEASUREMENT 1

Lower Band SAR (Channel 18700):

Date: 09/07/2023

| | |
|----------------------------------------|---------------------------------------------------------------------------------------------|
| Frequency (MHz) | 1860.000000 |
| Relative permittivity (real part) | 40.000000 |
| Relative permittivity (imaginary part) | 13.411700 |
| Conductivity (S/m) | 1.400405 |
| Variation (%) | -4.710000 |
| Crest Factor | 1.0 |
| Probe Conversion factor | 2.23 |
| E-Field Probe: | SSE2 (SN 25/22 EPGO375) |
| Area Scan | <u>dx=8mm dy=8mm, h= 5.00 mm</u> |
| ZoomScan | <u>5x5x7, dx=8mm dy=8mm</u> <u>dz=5mm, Complete/ndx=8mm dy=8mm, h=</u> <u>5.00 mm</u> |
| Phantom | <u>Validation plane</u> |
| Device Position | <u>Body back(0mm)</u> |
| Band | <u>LTE band 2 (1 RB#0)</u> |

SURFACE SAR

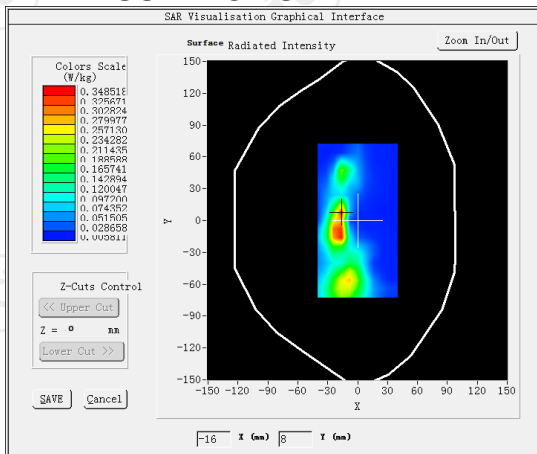

VOLUME SAR

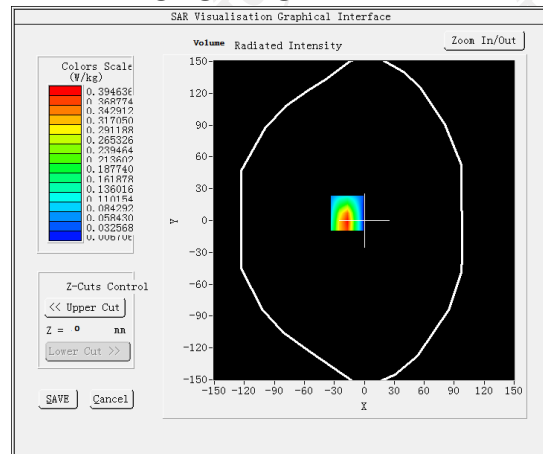

Maximum location: X=-17.00, Y=7.00 SAR Peak: 0.80 W/kg

SAR 10g (W/Kg)

0.155928

SAR 1g (W/Kg)

0.369818

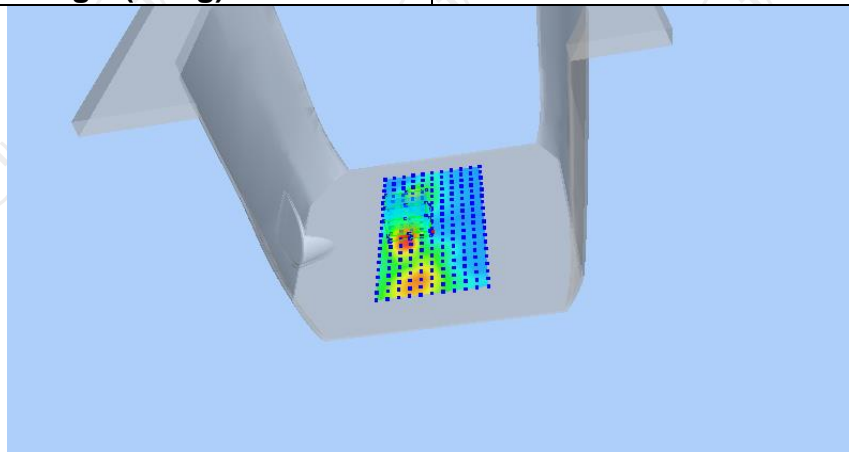

| | | | | | |
|-------------------|---------------|---------------|---------------|---------------|---------------|
| Z (mm) | 0.00 | 4.00 | 9.00 | 14.00 | 19.00 |
| SAR (W/Kg) | 1.3076 | 0.3946 | 0.0772 | 0.0541 | 0.0130 |

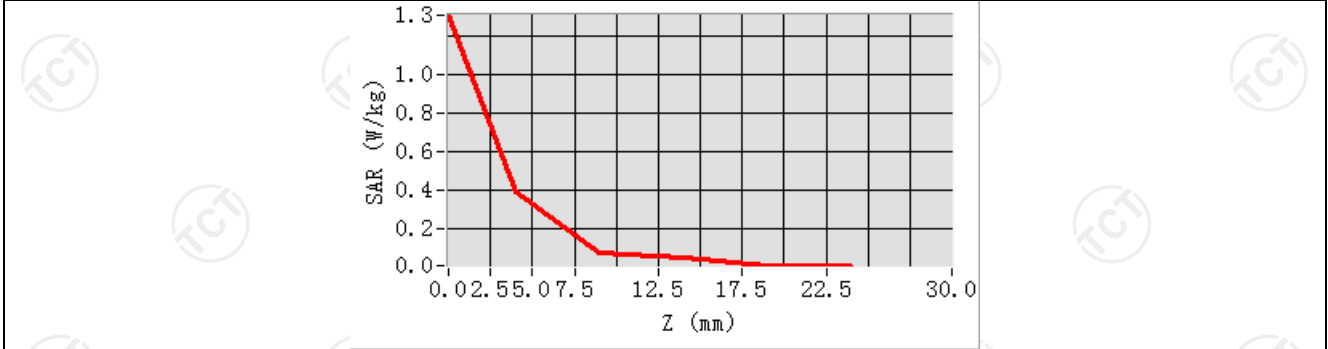

Hot spot position

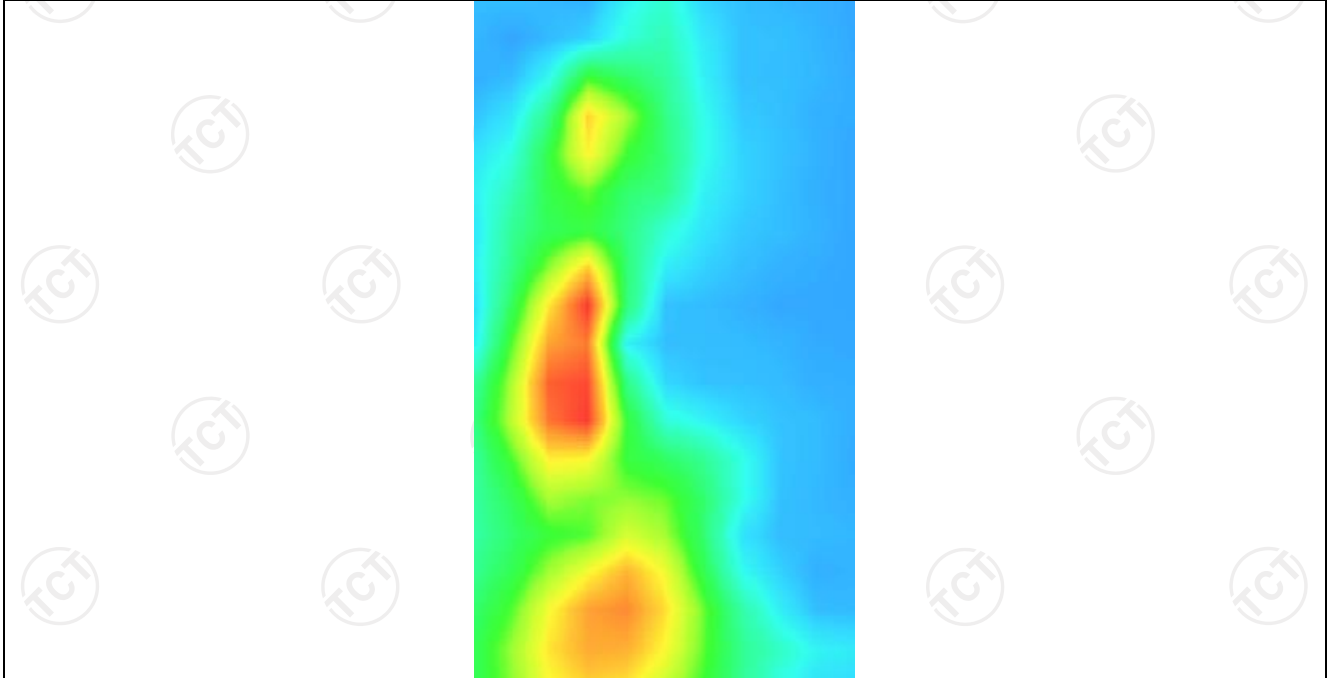

MEASUREMENT 2

Lower Band SAR (Channel 18700):

Date: 09/07/2023

| | |
|-----------------------------------------------|-------------------------------------------------------------------|
| Frequency (MHz) | 1860.000000 |
| Relative permittivity (real part) | 40.000000 |
| Relative permittivity (imaginary part) | 13.411700 |
| Conductivity (S/m) | 1.400405 |
| Variation (%) | -4.890000 |
| Crest Factor | 1.0 |
| Probe Conversion factor | 2.23 |
| E-Field Probe: | SSE2 (SN 25/22 EPG0375) |
| Area Scan | dx=8mm dy=8mm, h= 5.00 mm |
| ZoomScan | 5x5x7,dx=8mm dy=8mm dz=5mm,Complete/ndx=8mm dy=8mm, h= 5.00 mm |
| Phantom | Validation plane |
| Device Position | Body back(hotspot 0mm) |
| Band | LTE band 2 (1 RB#0) |

SURFACE SAR

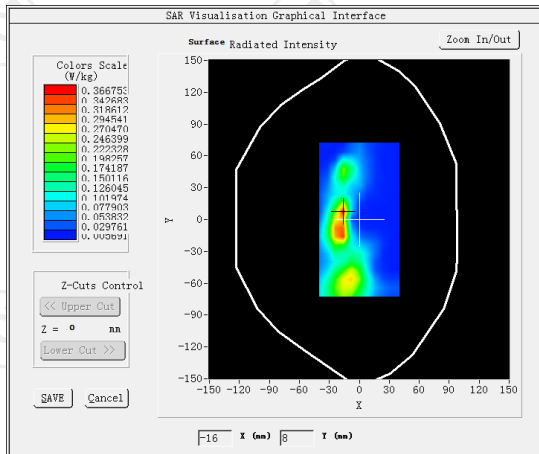

VOLUME SAR

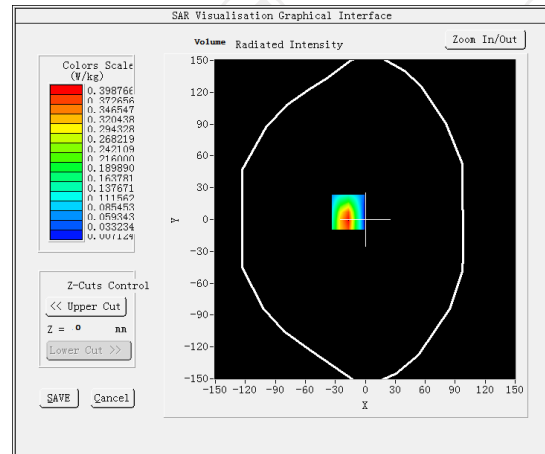

Maximum location: X=-17.00, Y=7.00 SAR Peak: 0.81 W/kg

SAR 10g (W/Kg)

0.163899

SAR 1g (W/Kg)

0.378119

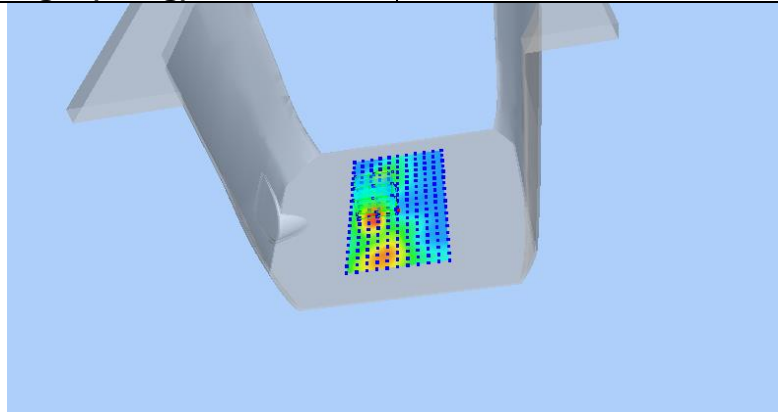

| | | | | | |
|-------------------|---------------|---------------|---------------|---------------|---------------|
| Z (mm) | 0.00 | 4.00 | 9.00 | 14.00 | 19.00 |
| SAR (W/Kg) | 1.2777 | 0.3988 | 0.0883 | 0.0603 | 0.0181 |

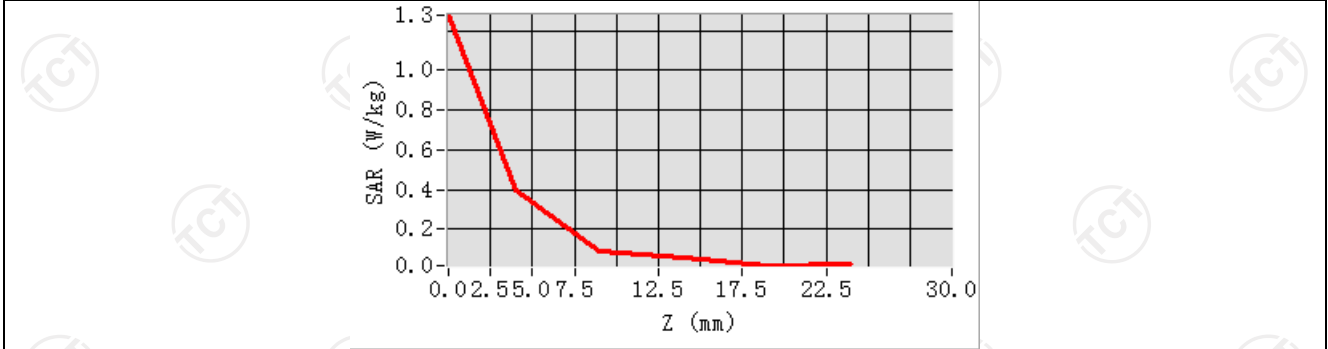

Hot spot position

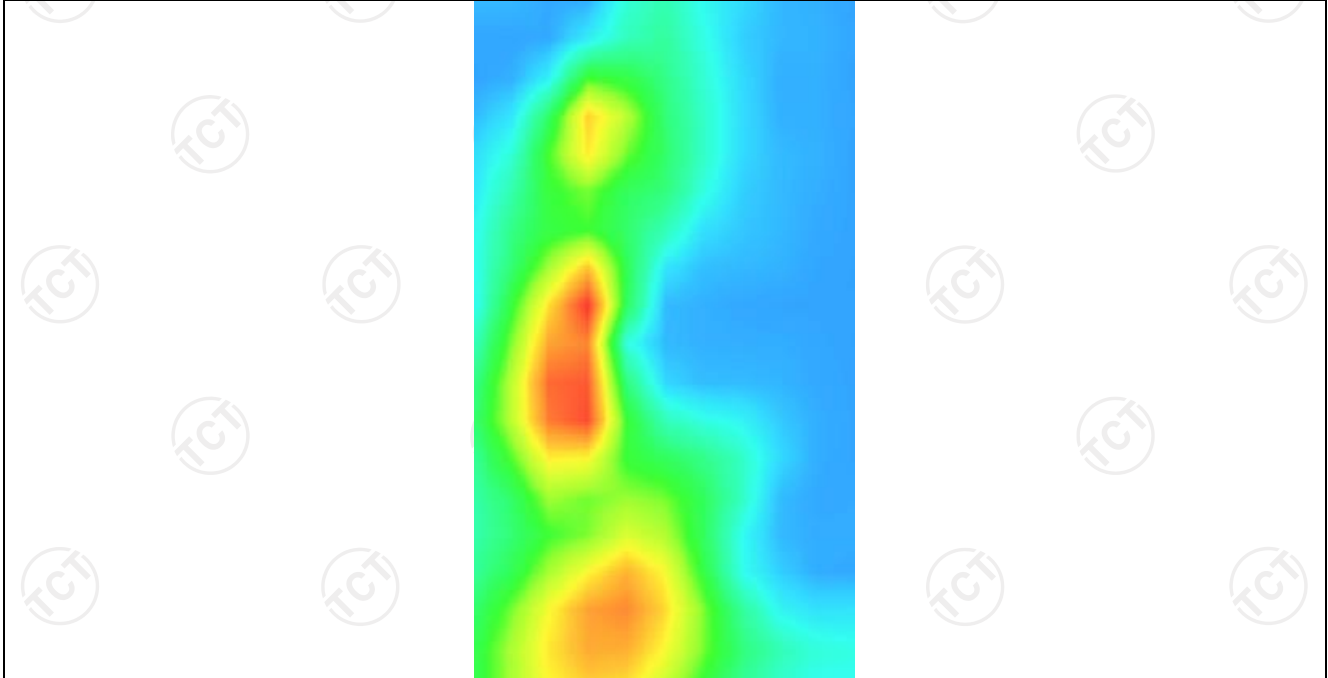

LTE Band 4

MEASUREMENT 1

High Band SAR (Channel 20300):

Date: 09/06/2023

| | |
|----------------------------------------|---------------------------------------------------------------------------------------------|
| Frequency (MHz) | 1745.000000 |
| Relative permittivity (real part) | 40.115910 |
| Relative permittivity (imaginary part) | 14.136136 |
| Conductivity (S/m) | 1.360603 |
| Variation (%) | -0.590000 |
| Crest Factor | 1.0 |
| Probe Conversion factor | 2.08 |
| E-Field Probe: | SSE2 (SN 25/22 EPGO375) |
| Area Scan | <u>dx=8mm dy=8mm, h= 5.00 mm</u> |
| ZoomScan | <u>5x5x7, dx=8mm dy=8mm</u> <u>dz=5mm, Complete/ndx=8mm dy=8mm, h=</u> <u>5.00 mm</u> |
| Phantom | <u>Validation plane</u> |
| Device Position | <u>Body back(0mm)</u> |
| Band | <u>LTE band 4(50 RB#50)</u> |

SURFACE SAR

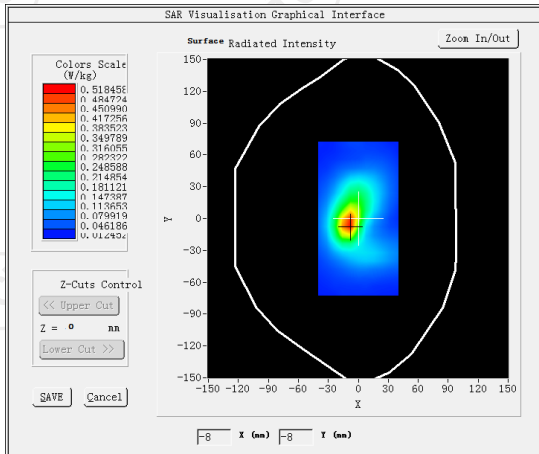

VOLUME SAR

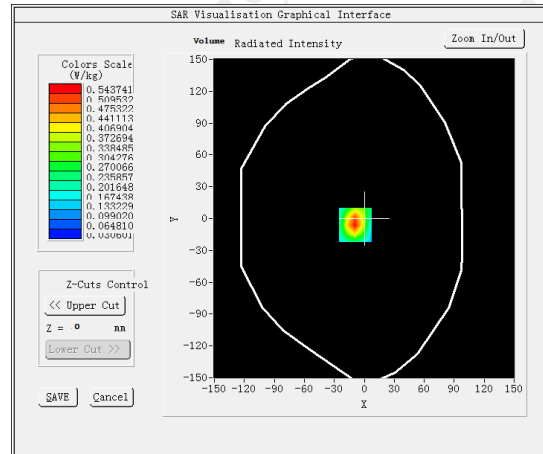

Maximum location: X=-9.00, Y=-6.00 SAR Peak: 0.93 W/kg

SAR 10g (W/Kg)

0.257761

SAR 1g (W/Kg)

0.506009

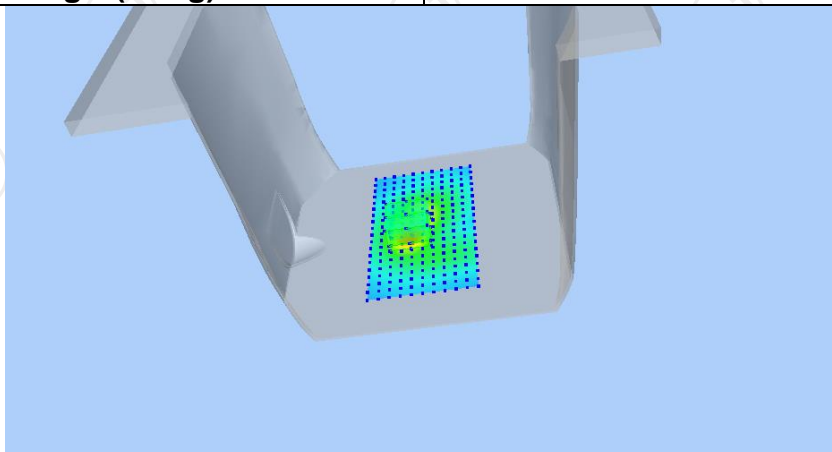

| | | | | | |
|-------------------|---------------|---------------|---------------|---------------|---------------|
| Z (mm) | 0.00 | 4.00 | 9.00 | 14.00 | 19.00 |
| SAR (W/Kg) | 0.9234 | 0.5437 | 0.2724 | 0.1437 | 0.0889 |

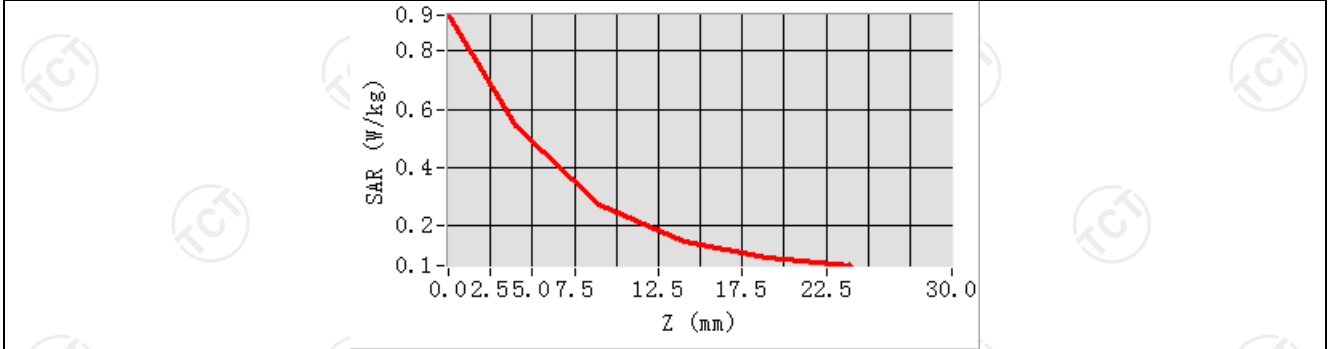

Hot spot position

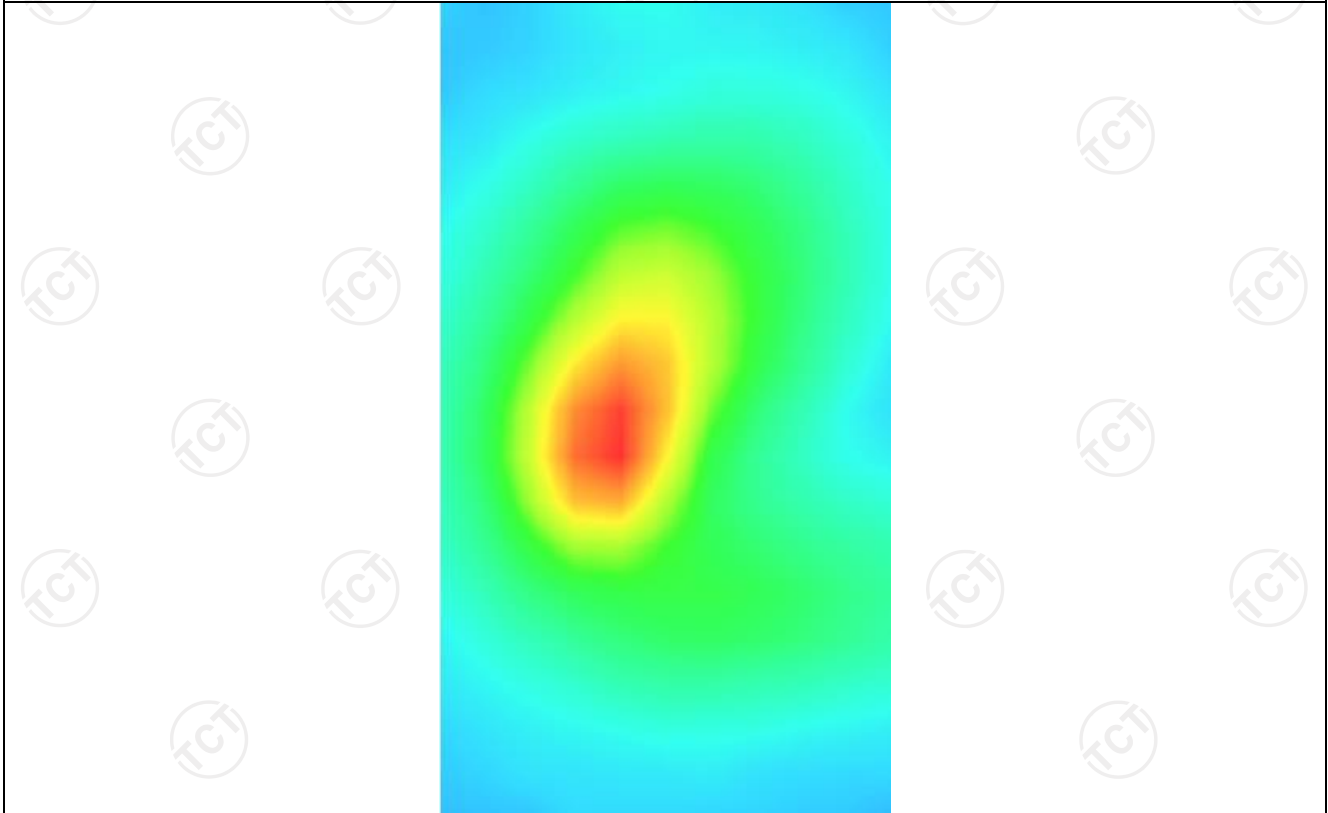

MEASUREMENT 2

High Band SAR (Channel 20300):

Date: 09/06/2023

| | |
|-----------------------------------------------|---------------------------------------------------------------------------------------------|
| Frequency (MHz) | 1745.000000 |
| Relative permittivity (real part) | 40.115910 |
| Relative permittivity (imaginary part) | 14.136136 |
| Conductivity (S/m) | 1.360603 |
| Variation (%) | -2.450000 |
| Crest Factor | 1.0 |
| Probe Conversion factor | 2.08 |
| E-Field Probe: | SSE2 (SN 25/22 EPG0375) |
| Area Scan | <u>dx=8mm dy=8mm, h= 5.00 mm</u> |
| ZoomScan | <u>5x5x7, dx=8mm dy=8mm</u> <u>dz=5mm, Complete/ndx=8mm dy=8mm, h=</u> <u>5.00 mm</u> |
| Phantom | <u>Validation plane</u> |
| Device Position | <u>Body back(hotspot 0mm)</u> |
| Band | <u>LTE band 4(50 RB#50)</u> |

SURFACE SAR

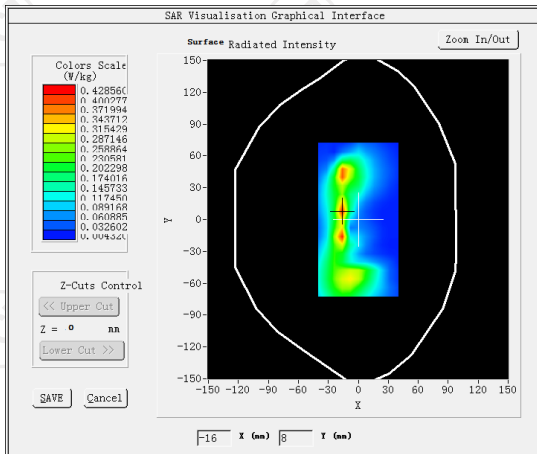

VOLUME SAR

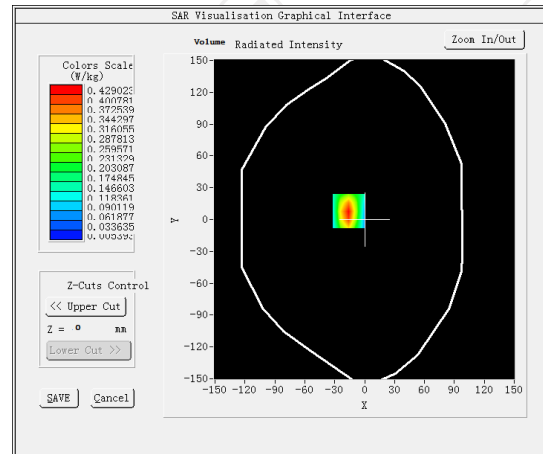

Maximum location: X=-16.00, Y=8.00 SAR Peak: 0.97 W/kg

SAR 10g (W/Kg)

0.174482

SAR 1g (W/Kg)

0.412995

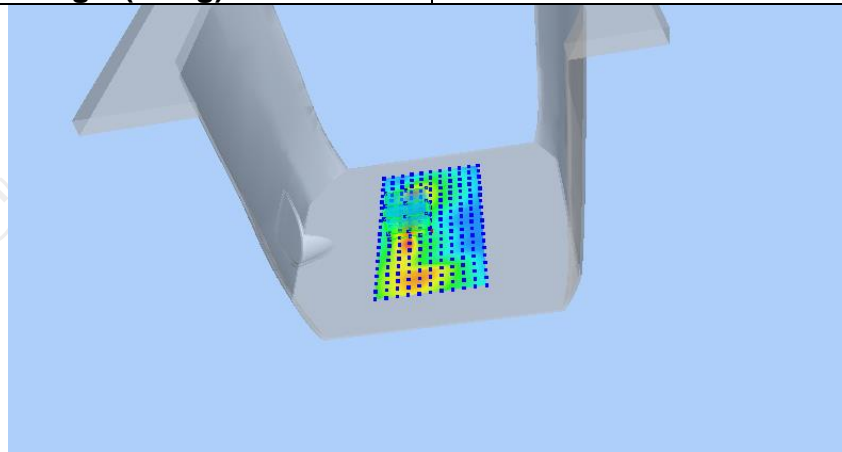

| | | | | | |
|-------------------|---------------|---------------|---------------|---------------|---------------|
| Z (mm) | 0.00 | 4.00 | 9.00 | 14.00 | 19.00 |
| SAR (W/Kg) | 0.9555 | 0.4290 | 0.1285 | 0.0343 | 0.0138 |

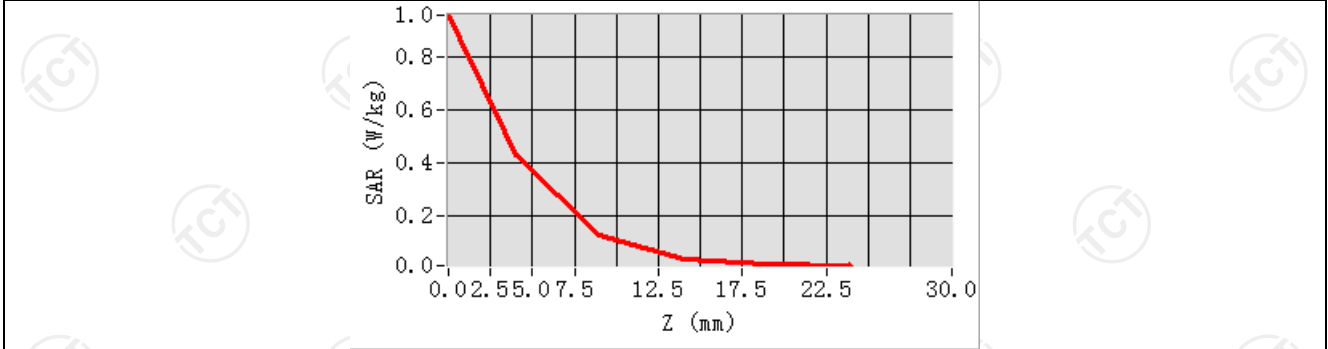

Hot spot position

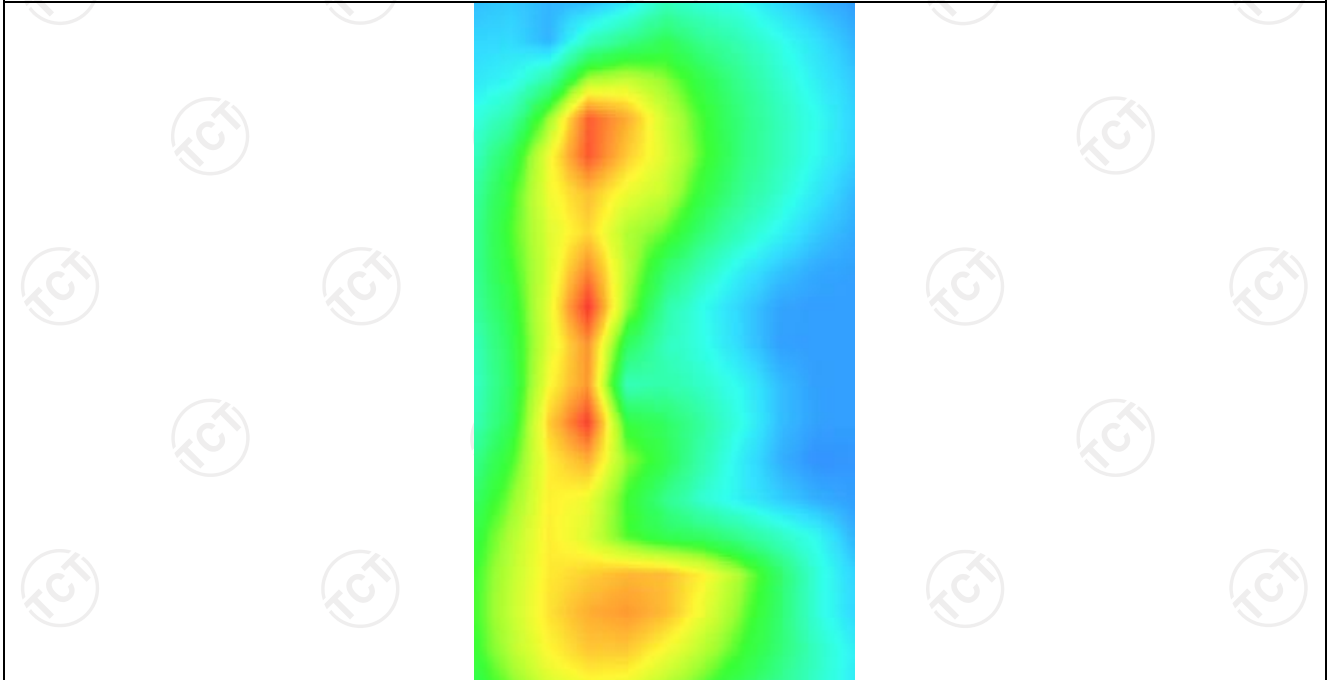

LTE Band 5

MEASUREMENT 2

Middle Band SAR (Channel 20525):

Date: 09/05/2023

| | |
|----------------------------------------|-------------------------------------------------------------------------------------------|
| Frequency (MHz) | 836.500000 |
| Relative permittivity (real part) | 41.500000 |
| Relative permittivity (imaginary part) | 19.400000 |
| Conductivity (S/m) | 0.901561 |
| Variation (%) | 4.750000 |
| Crest Factor | 1.0 |
| Probe Conversion factor | 1.80 |
| E-Field Probe: | SSE2 (SN 25/22 EPGO375) |
| Area Scan | <u>dx=8mm dy=8mm, h= 5.00 mm</u> |
| ZoomScan | <u>5x5x7,dx=8mm dy=8mm</u> <u>dz=5mm,Complete/ndx=8mm dy=8mm, h=</u> <u>5.00 mm</u> |
| Phantom | <u>Validation plane</u> |
| Device Position | <u>Body back(0mm)</u> |
| Band | <u>LTE band 5(25 RB#0)</u> |

SURFACE SAR

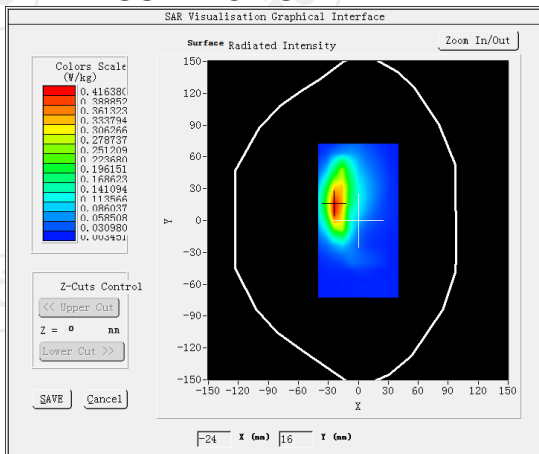

VOLUME SAR

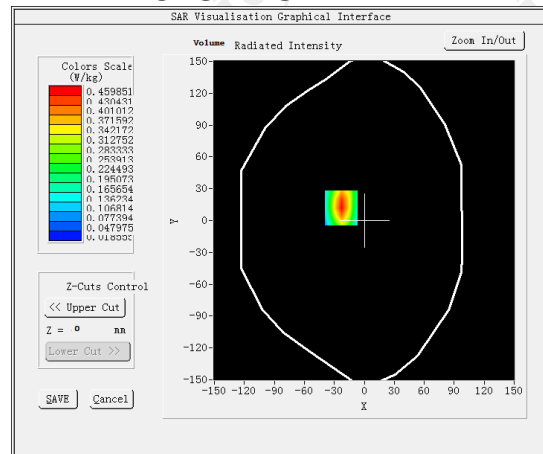

Maximum location: X=-23.00, Y=12.00 SAR Peak: 0.80 W/kg

SAR 10g (W/Kg)

0.215744

SAR 1g (W/Kg)

0.429163

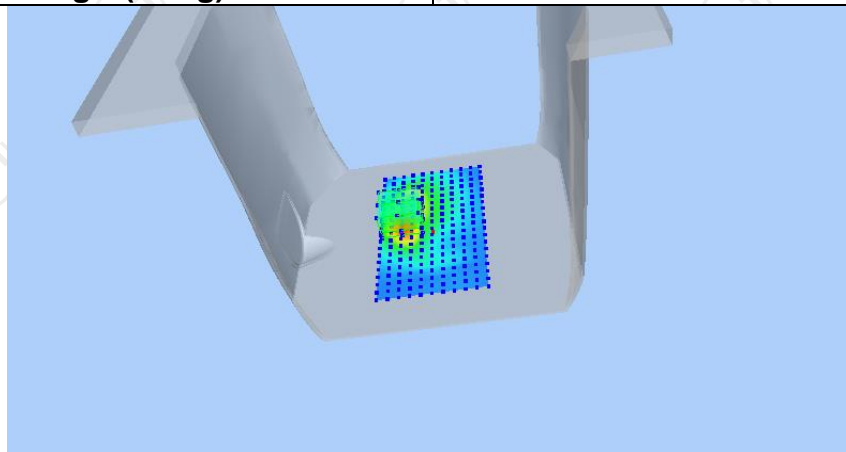

| | | | | | |
|-------------------|---------------|---------------|---------------|---------------|---------------|
| Z (mm) | 0.00 | 4.00 | 9.00 | 14.00 | 19.00 |
| SAR (W/Kg) | 0.8019 | 0.4599 | 0.2197 | 0.1086 | 0.0628 |

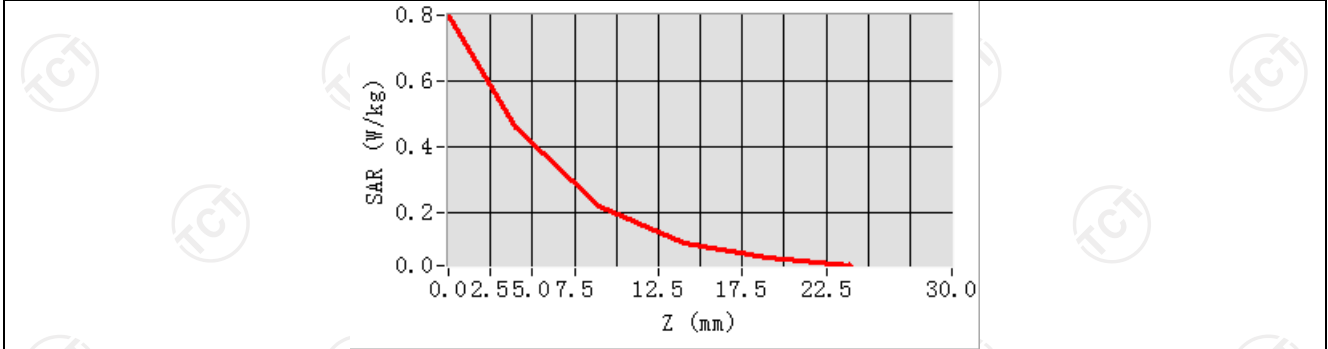

Hot spot position

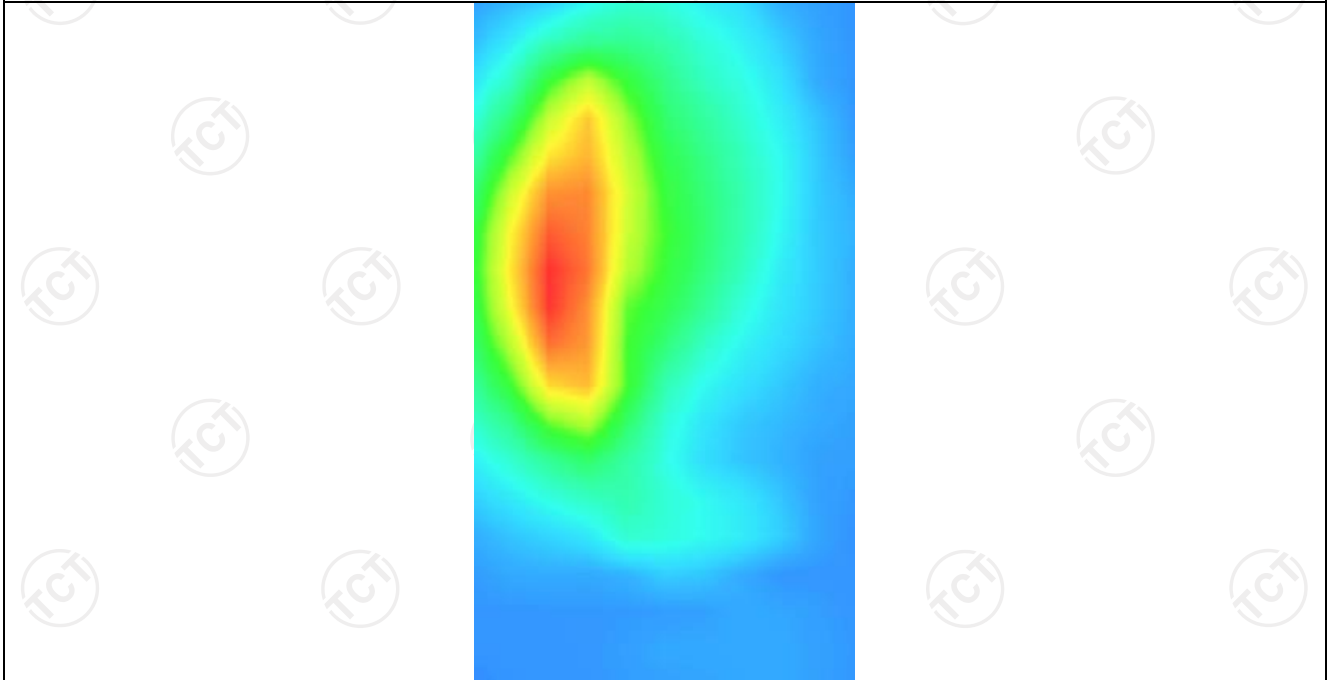

MEASUREMENT 2

Middle Band SAR (Channel 20525):

Date: 09/05/2023

| | |
|----------------------------------------|-------------------------------------------------------------------|
| Frequency (MHz) | 836.500000 |
| Relative permittivity (real part) | 41.500000 |
| Relative permittivity (imaginary part) | 19.400000 |
| Conductivity (S/m) | 0.901561 |
| Variation (%) | -4.640000 |
| Crest Factor | 1.0 |
| Probe Conversion factor | 1.80 |
| E-Field Probe: | SSE2 (SN 25/22 EPG0375) |
| Area Scan | dx=8mm dy=8mm, h= 5.00 mm |
| ZoomScan | 5x5x7,dx=8mm dy=8mm dz=5mm,Complete/ndx=8mm dy=8mm, h= 5.00 mm |
| Phantom | Validation plane |
| Device Position | Body back((hotspot 10mm) |
| Band | LTE band 5(25 RB#0) |

SURFACE SAR

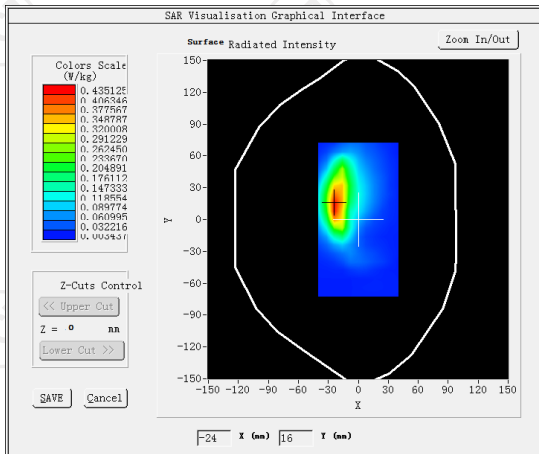

VOLUME SAR

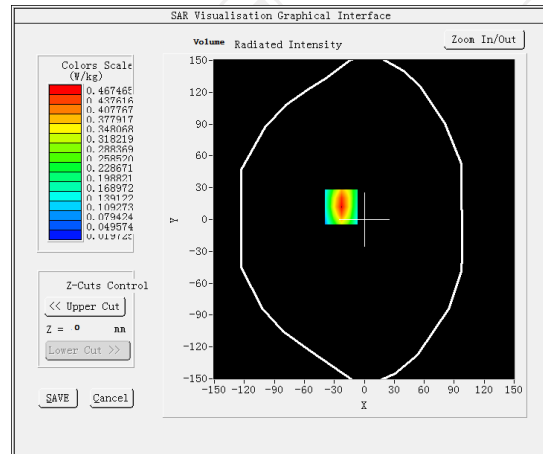

Maximum location: X=-23.00, Y=12.00 SAR Peak: 0.81 W/kg

SAR 10g (W/Kg)

0.220752

SAR 1g (W/Kg)

0.435807

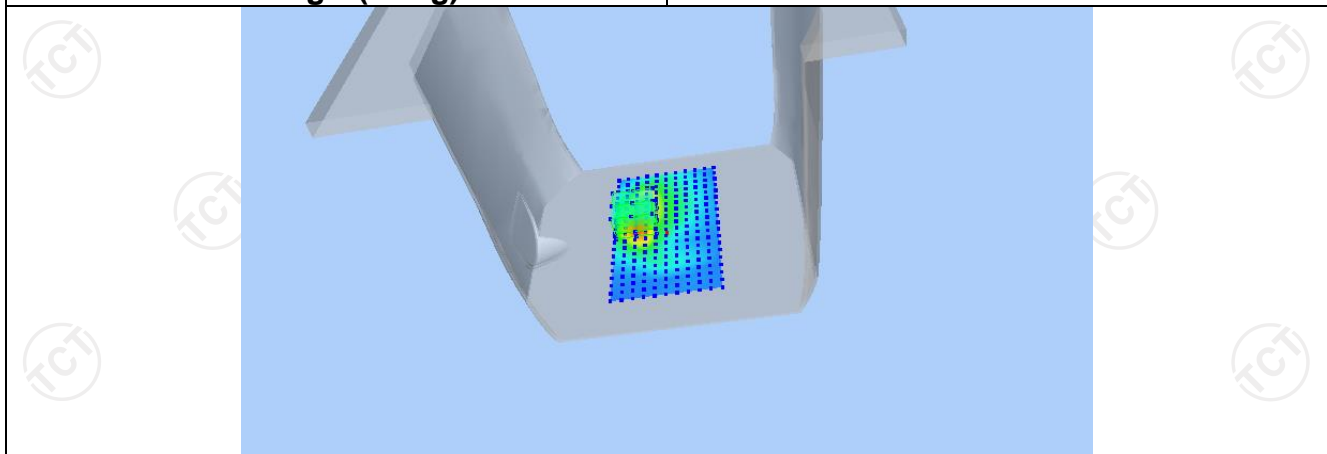

| | | | | | |
|-------------------|---------------|---------------|---------------|---------------|---------------|
| Z (mm) | 0.00 | 4.00 | 9.00 | 14.00 | 19.00 |
| SAR (W/Kg) | 0.8074 | 0.4675 | 0.2263 | 0.1127 | 0.0645 |

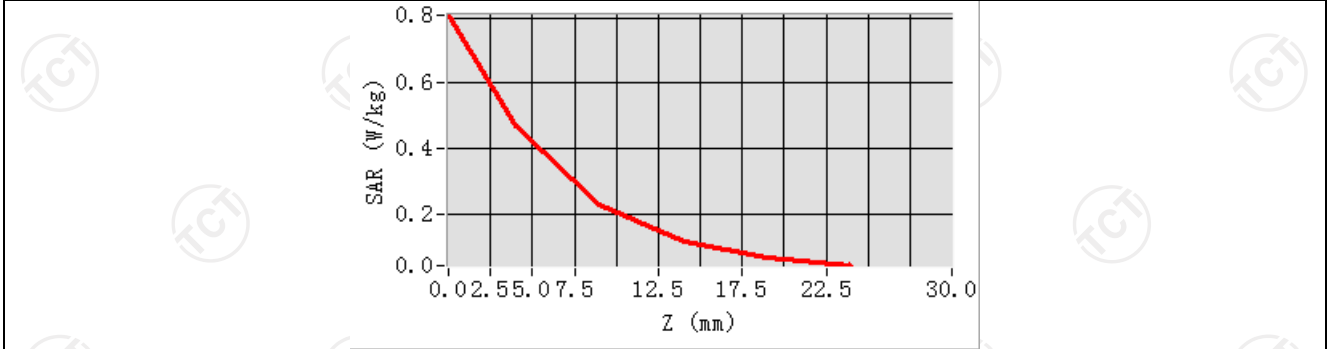

Hot spot position

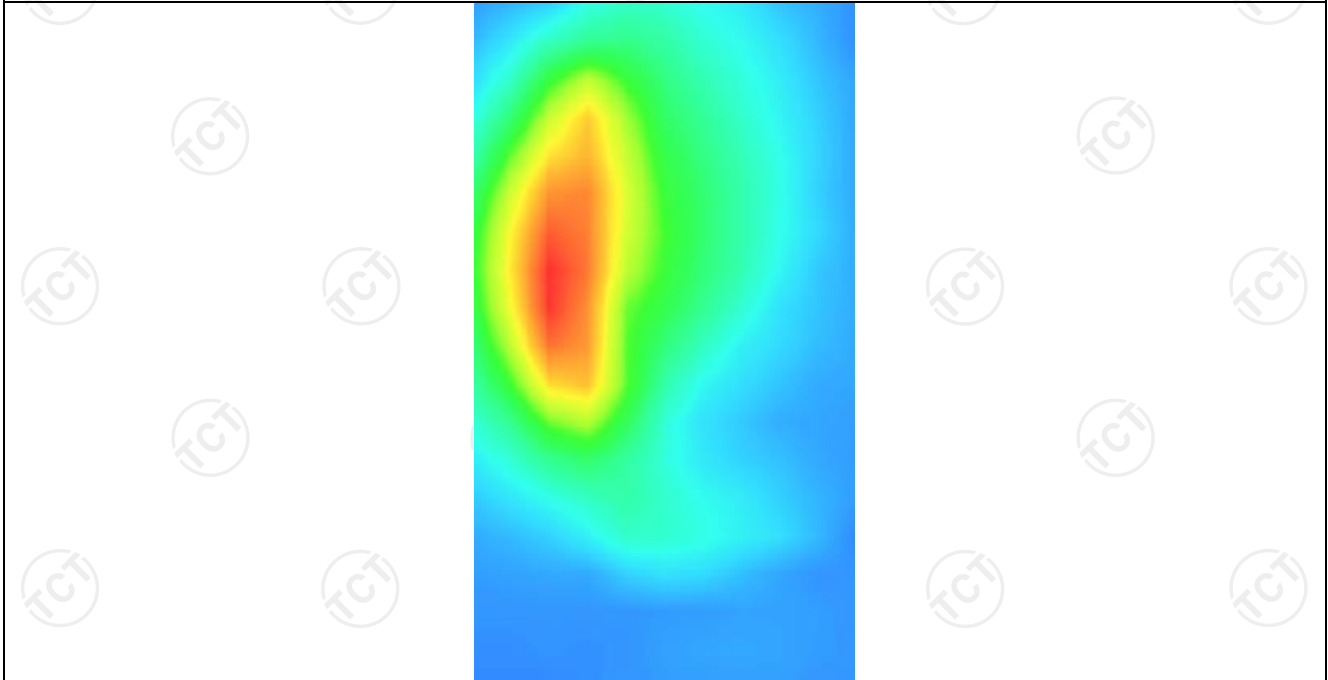

LTE Band 12

MEASUREMENT 1

Middle Band SAR (Channel 23095):

Date: 09/04/2023

| | |
|----------------------------------------|---------------------------------------------------------------------------------------------|
| Frequency (MHz) | 707.500000 |
| Relative permittivity (real part) | 42.126667 |
| Relative permittivity (imaginary part) | 23.264000 |
| Conductivity (S/m) | 0.914404 |
| Variation (%) | 4.630000 |
| Crest Factor | 1.0 |
| Probe Conversion factor | 1.71 |
| E-Field Probe: | SSE2 (SN 25/22 EPGO375) |
| Area Scan | <u>dx=8mm dy=8mm, h= 5.00 mm</u> |
| ZoomScan | <u>5x5x7, dx=8mm dy=8mm</u> <u>dz=5mm, Complete/ndx=8mm dy=8mm, h=</u> <u>5.00 mm</u> |
| Phantom | <u>Validation plane</u> |
| Device Position | <u>Body back(0mm)</u> |
| Band | <u>LTE band 12(25 RB#0)</u> |

SURFACE SAR

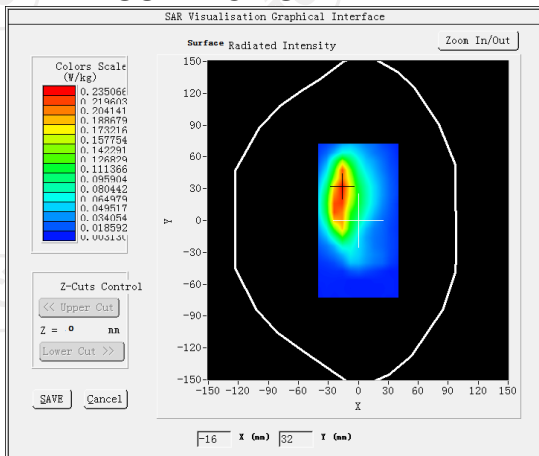

VOLUME SAR

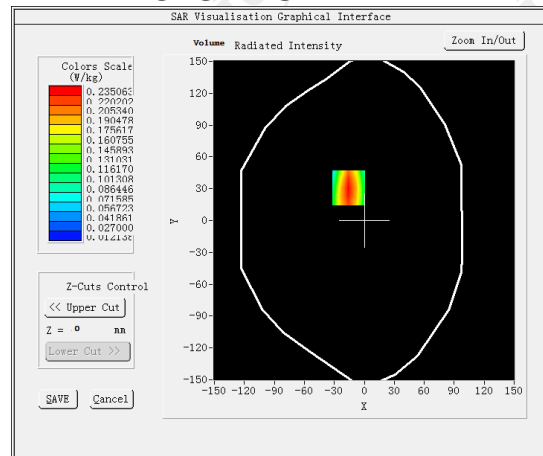

Maximum location: X=-16.00, Y=31.00 SAR Peak:0.43 W/kg

SAR 10g (W/Kg)

0.119068

SAR 1g (W/Kg)

0.228315

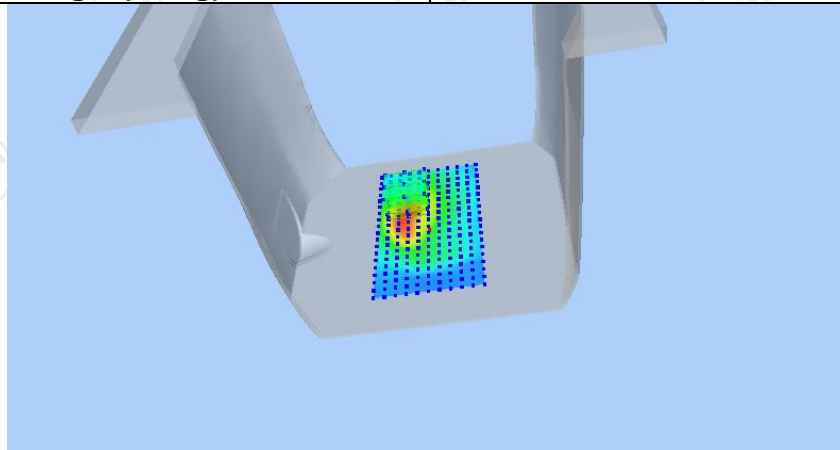

| | | | | | |
|------------|--------|--------|--------|--------|--------|
| Z (mm) | 0.00 | 4.00 | 9.00 | 14.00 | 19.00 |
| SAR (W/Kg) | 0.4263 | 0.2351 | 0.1055 | 0.0490 | 0.0278 |

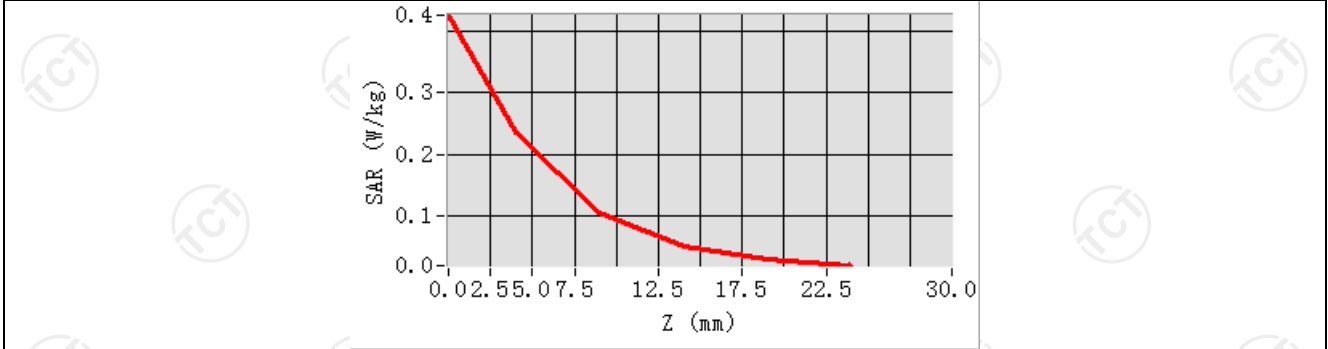

Hot spot position



MEASUREMENT 2

Middle Band SAR (Channel 23095):

Date: 09/04/2023

| | |
|----------------------------------------|---------------------------------------------------------------------|
| Frequency (MHz) | 707.500000 |
| Relative permittivity (real part) | 42.126667 |
| Relative permittivity (imaginary part) | 23.264000 |
| Conductivity (S/m) | 0.914404 |
| Variation (%) | 0.060000 |
| Crest Factor | 1.0 |
| Probe Conversion factor | 1.71 |
| E-Field Probe: | SSE2 (SN 25/22 EPG0375) |
| Area Scan | dx=8mm dy=8mm, h= 5.00 mm |
| ZoomScan | 5x5x7, dx=8mm dy=8mm dz=5mm, Complete/ndx=8mm dy=8mm, h= 5.00 mm |
| Phantom | Validation plane |
| Device Position | Body back(hotspot 0mm) |
| Band | LTE band 12(25 RB#0) |

SURFACE SAR

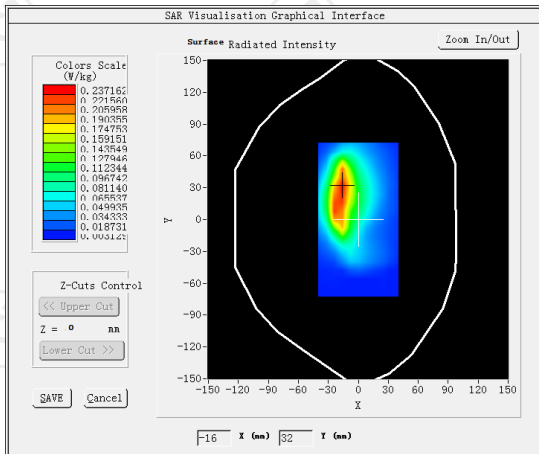

VOLUME SAR

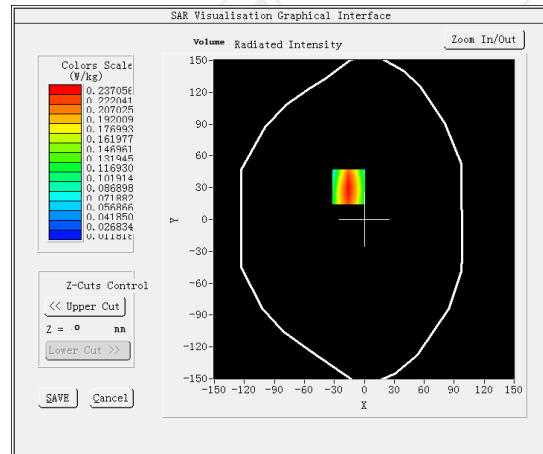

Maximum location: X=-16.00, Y=31.00 SAR Peak: 0.42W/kg

SAR 10g (W/Kg)

0.122208

SAR 1g (W/Kg)

0.229663

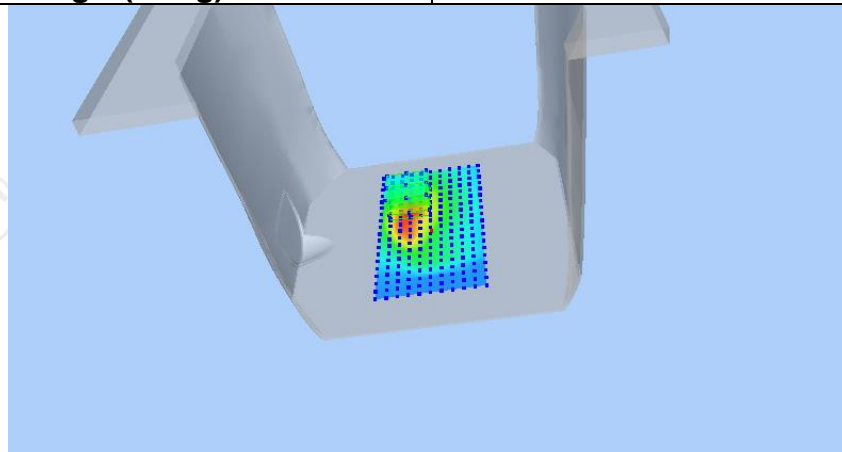

| | | | | | |
|-------------------|---------------|---------------|---------------|---------------|---------------|
| Z (mm) | 0.00 | 4.00 | 9.00 | 14.00 | 19.00 |
| SAR (W/Kg) | 0.4105 | 0.2371 | 0.1139 | 0.0557 | 0.0309 |

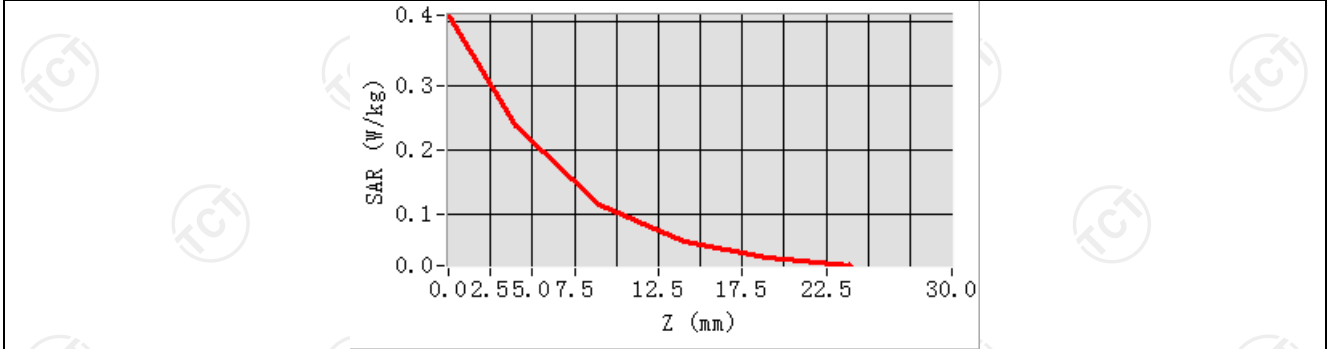

Hot spot position



LTE Band 41(HPUE)

MEASUREMENT 1

Low Band SAR (Channel 39750):

Date: 09/11/2023

| | |
|-----------------------------------------------|-------------------------------------------------------------------------------------------|
| Frequency (MHz) | 2506.000000 |
| Relative permittivity (real part) | 39.009335 |
| Relative permittivity (imaginary part) | 13.553667 |
| Conductivity (S/m) | 1.952481 |
| Variation (%) | -0.550000 |
| Crest Factor | 1.0 |
| Probe Conversion factor | 4.36 |
| E-Field Probe: | SSE2 (SN 25/22 EPG0375) |
| Area Scan | <u>dx=8mm dy=8mm, h= 5.00 mm</u> |
| ZoomScan | <u>5x5x7,dx=8mm dy=8mm</u> <u>dz=5mm,Complete/ndx=8mm dy=8mm, h=</u> <u>5.00 mm</u> |
| Phantom | Validation plane |
| Device Position | Body back(0mm) |
| Band | <u>LTE band 41(1 RB#0)</u> |

SURFACE SAR

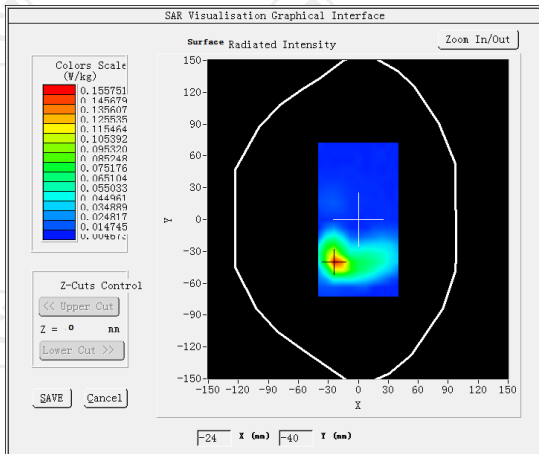

VOLUME SAR

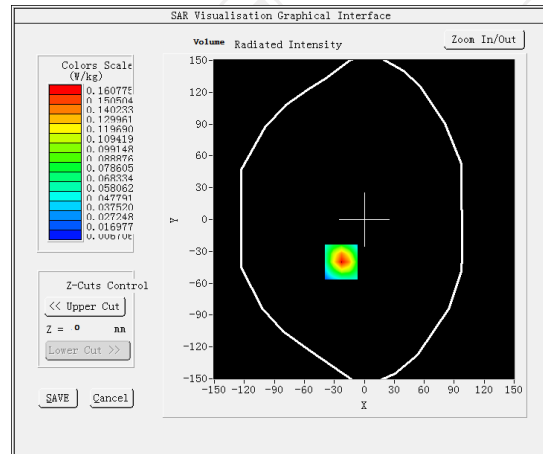

Maximum location: X=7.00, Y=-23.00 SAR Peak: 0.94 W/kg

SAR 10g (W/Kg)

0.303978

SAR 1g (W/Kg)

0.514435

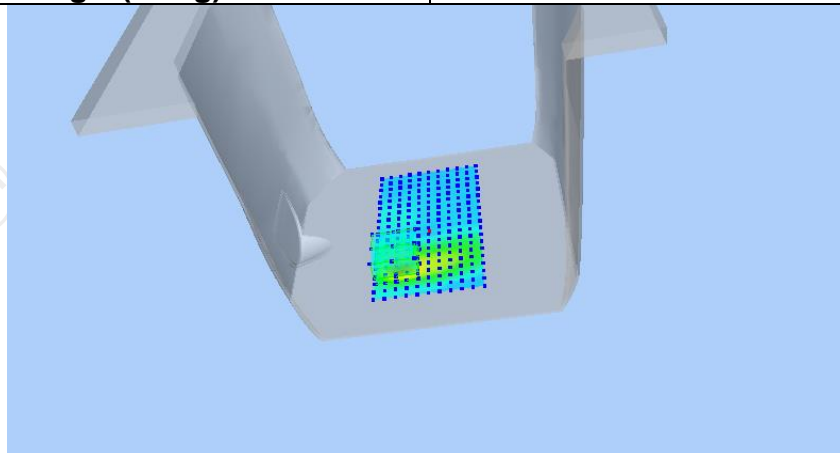

| | | | | | |
|-------------------|---------------|---------------|---------------|---------------|---------------|
| Z (mm) | 0.00 | 4.00 | 9.00 | 14.00 | 19.00 |
| SAR (W/Kg) | 0.9365 | 0.5845 | 0.3170 | 0.1765 | 0.1073 |

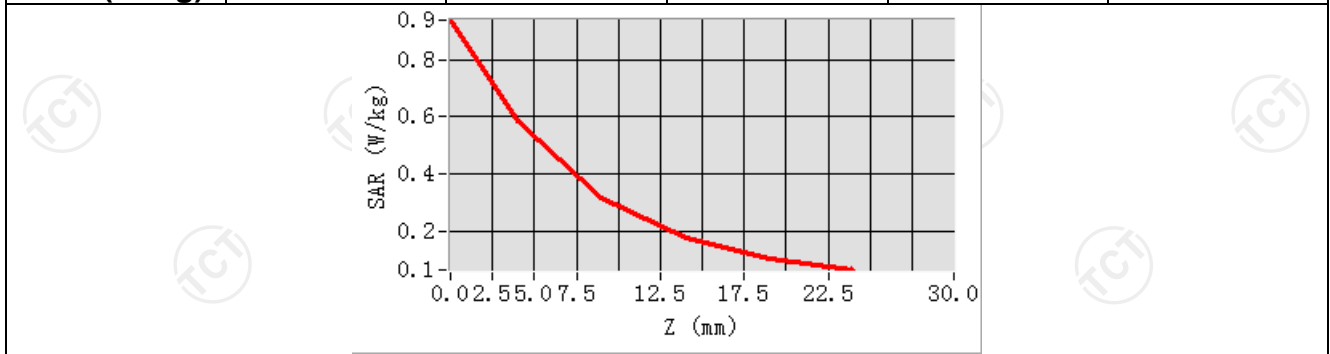

Hot spot position

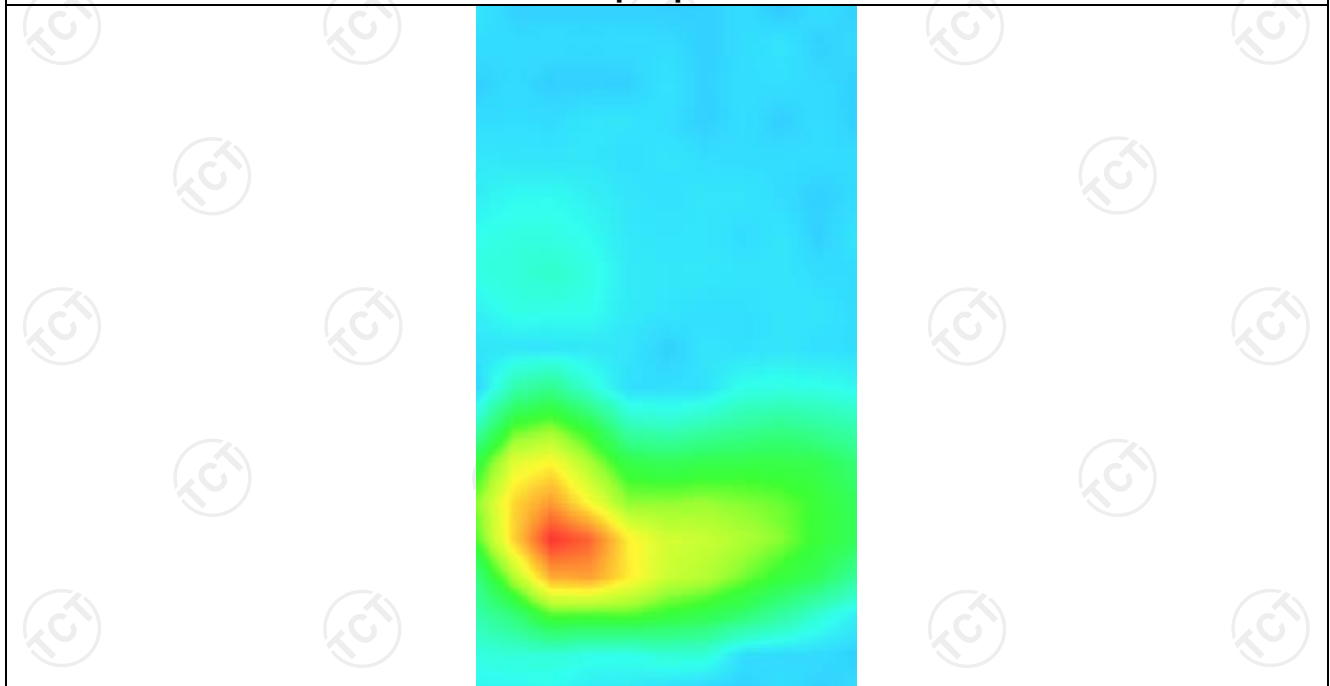

MEASUREMENT 2

Low Band SAR (Channel 39750):

Date: 09/11/2023

| | |
|----------------------------------------|-------------------------------------------------------------------------------------------|
| Frequency (MHz) | 2506.000000 |
| Relative permittivity (real part) | 39.009335 |
| Relative permittivity (imaginary part) | 13.553667 |
| Conductivity (S/m) | 1.952481 |
| Variation (%) | -3.100000 |
| Crest Factor | 1.0 |
| Probe Conversion factor | 4.36 |
| E-Field Probe: | SSE2 (SN 25/22 EPG0375) |
| Area Scan | <u>dx=8mm dy=8mm, h= 5.00 mm</u> |
| ZoomScan | <u>5x5x7,dx=8mm dy=8mm</u> <u>dz=5mm,Complete/ndx=8mm dy=8mm, h=</u> <u>5.00 mm</u> |
| Phantom | Validation plane |
| Device Position | <u>Body back(hotspot 0mm)</u> |
| Band | <u>LTE band 41(1 RB#0)</u> |

SURFACE SAR

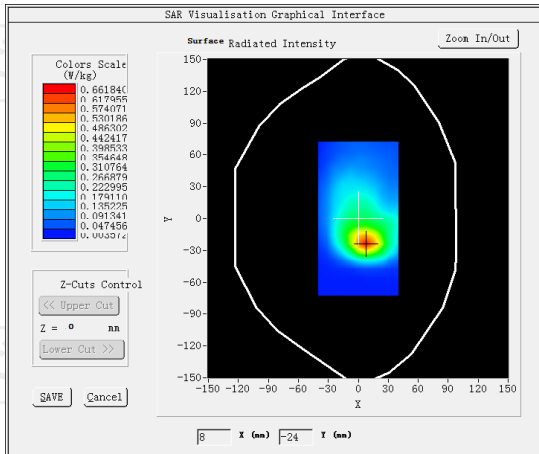

VOLUME SAR

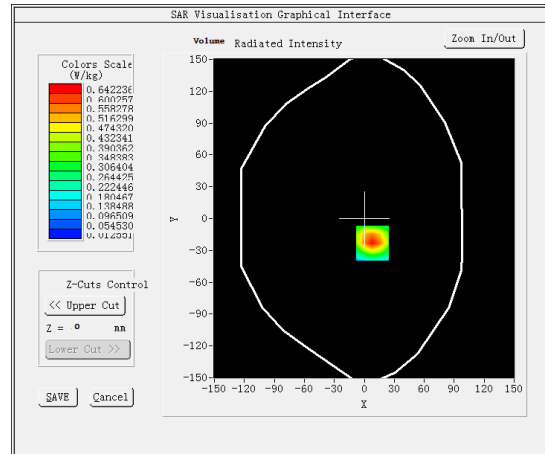

Maximum location: X=8.00, Y=-25.00 SAR Peak: 0.99 W/kg

SAR 10g (W/Kg)

0.344124

SAR 1g (W/Kg)

0.582590

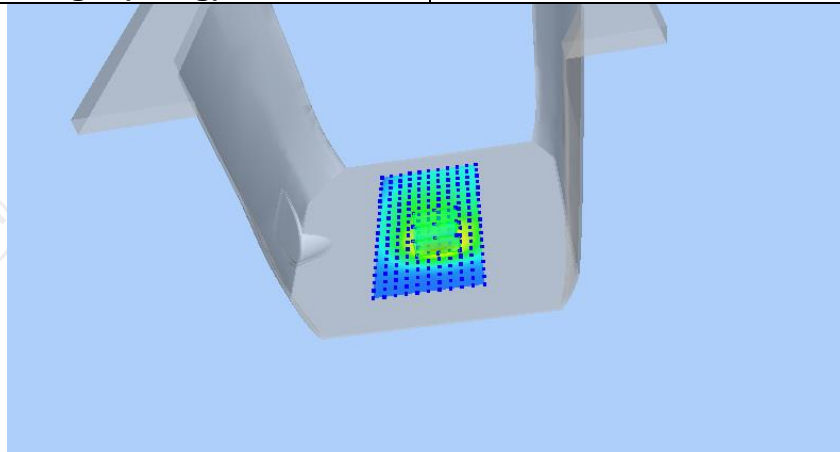

| | | | | | |
|-------------------|---------------|---------------|---------------|---------------|---------------|
| Z (mm) | 0.00 | 4.00 | 9.00 | 14.00 | 19.00 |
| SAR (W/Kg) | 0.9835 | 0.6422 | 0.3704 | 0.2169 | 0.1338 |

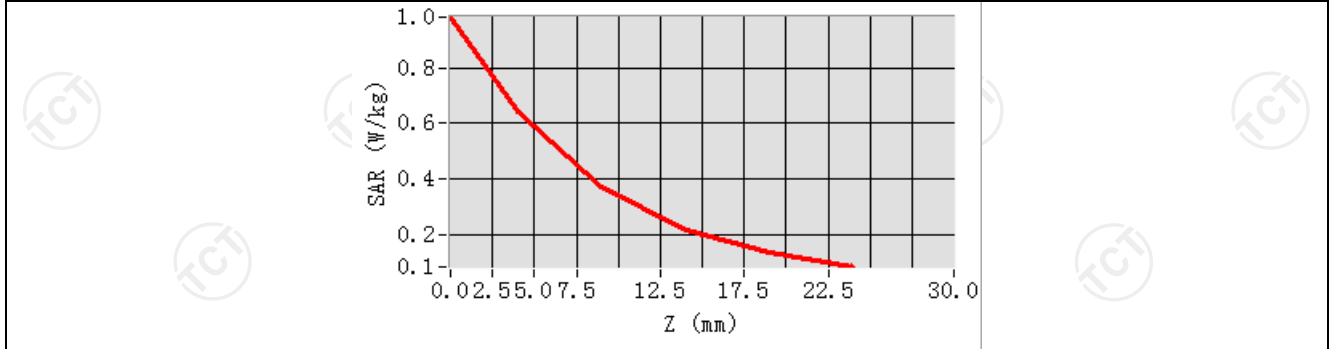

Hot spot position

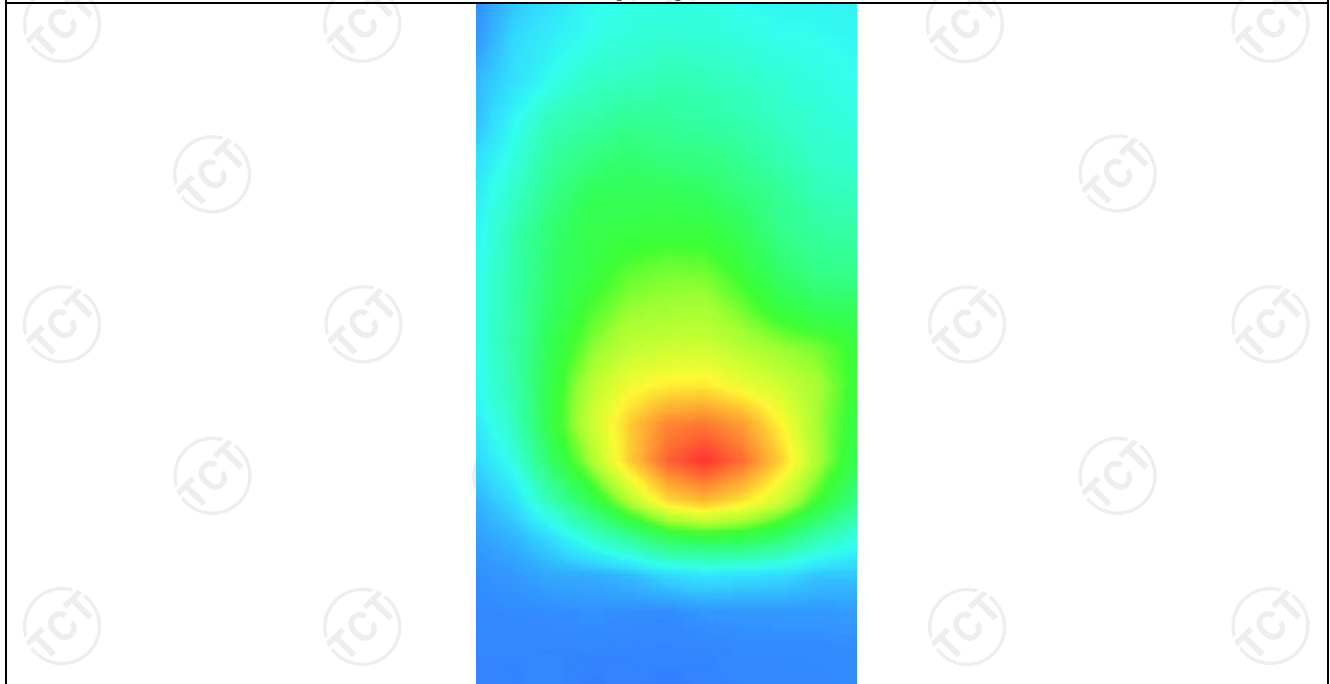

LTE Band 66

MEASUREMENT 1

High Band SAR (Channel132572):

Date: 09/06/2023

| | |
|-----------------------------------------------|-------------------------------------------------------------------------------------------|
| Frequency (MHz) | 1770.000000 |
| Relative permittivity (real part) | 40.115910 |
| Relative permittivity (imaginary part) | 14.136136 |
| Conductivity (S/m) | 1.360603 |
| Variation (%) | -3.160000 |
| Crest Factor | 1.0 |
| Probe Conversion factor | 1.71 |
| E-Field Probe: | SSE2 (SN 25/22 EPG0375) |
| Area Scan | <u>dx=8mm dy=8mm, h= 5.00 mm</u> |
| ZoomScan | <u>5x5x7,dx=8mm dy=8mm</u> <u>dz=5mm,Complete/ndx=8mm dy=8mm, h=</u> <u>5.00 mm</u> |
| Phantom | <u>Validation plane</u> |
| Device Position | <u>Body back(0mm)</u> |
| Band | <u>LTE band 66(50 RB#50)</u> |

SURFACE SAR

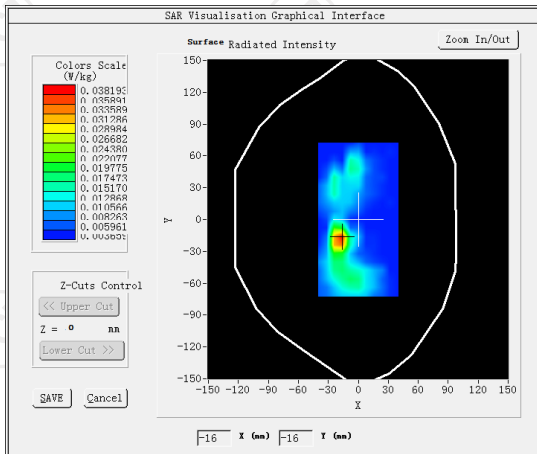

VOLUME SAR

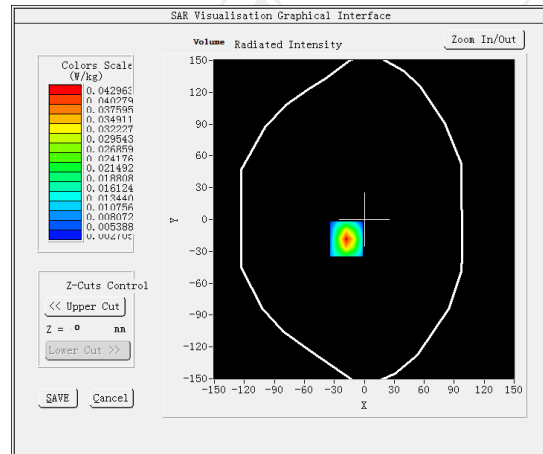

Maximum location: X=-18.00, Y=-18.00 SAR Peak: 0.63 W/kg

SAR 10g (W/Kg)

0.175792

SAR 1g (W/Kg)

0.343658

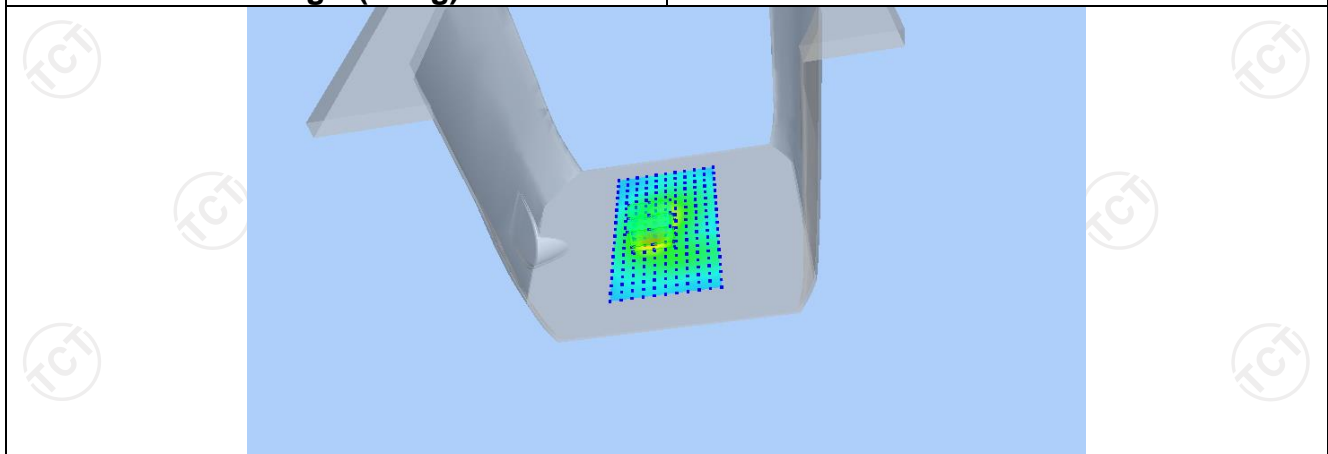

| | | | | | |
|------------|--------|--------|--------|--------|--------|
| Z (mm) | 0.00 | 4.00 | 9.00 | 14.00 | 19.00 |
| SAR (W/Kg) | 0.6287 | 0.3690 | 0.1845 | 0.0978 | 0.0617 |

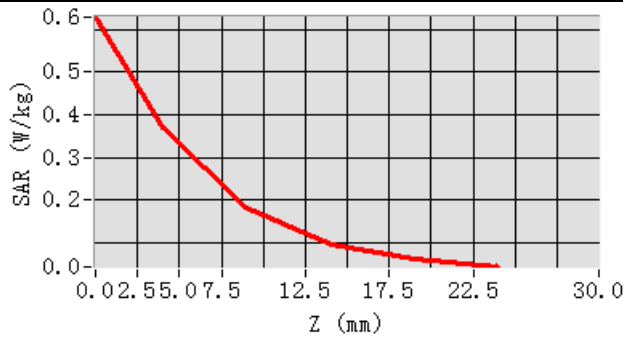

Hot spot position

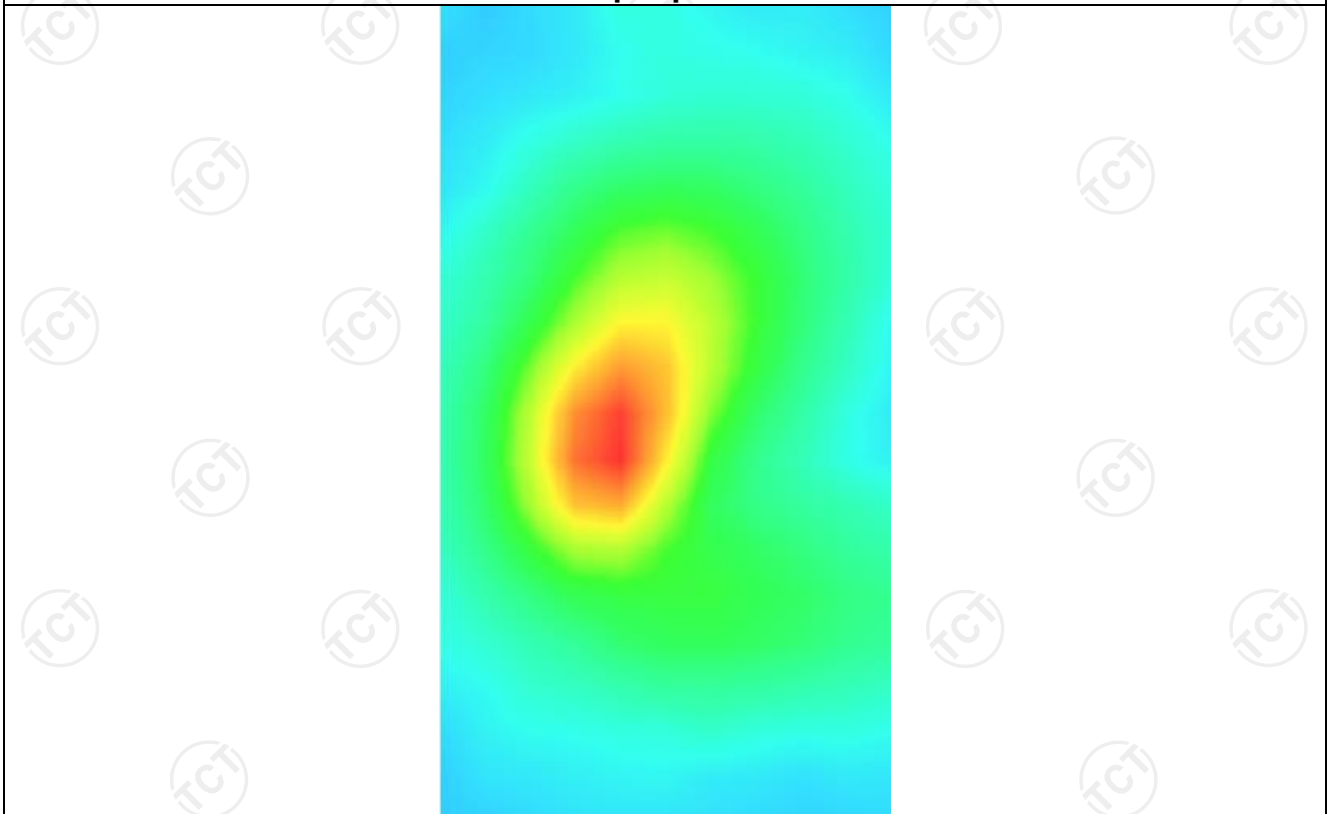

MEASUREMENT 2

High Band SAR (Channel132572):

Date: 09/06/2023

| | |
|----------------------------------------|-------------------------------------------------------------------------------------------|
| Frequency (MHz) | 1770.000000 |
| Relative permittivity (real part) | 40.115910 |
| Relative permittivity (imaginary part) | 14.136136 |
| Conductivity (S/m) | 1.360603 |
| Variation (%) | 0.830000 |
| Crest Factor | 1.0 |
| Probe Conversion factor | 1.71 |
| E-Field Probe: | SSE2 (SN 25/22 EPG0375) |
| Area Scan | <u>dx=8mm dy=8mm, h= 5.00 mm</u> |
| ZoomScan | <u>5x5x7,dx=8mm dy=8mm</u> <u>dz=5mm,Complete/ndx=8mm dy=8mm, h=</u> <u>5.00 mm</u> |
| Phantom | <u>Validation plane</u> |
| Device Position | <u>Body back(hotspot 10mm)</u> |
| Band | <u>LTE band 66(50 RB#50)</u> |

SURFACE SAR

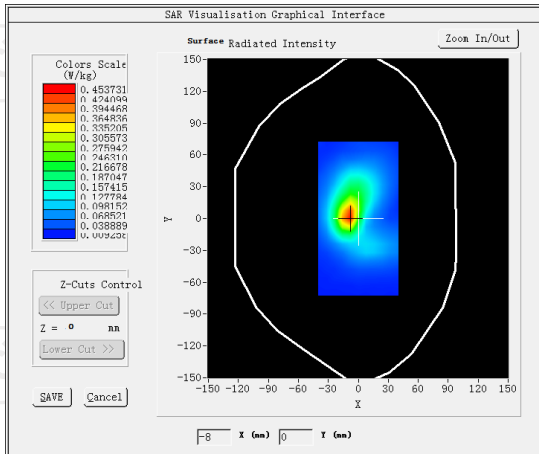

VOLUME SAR

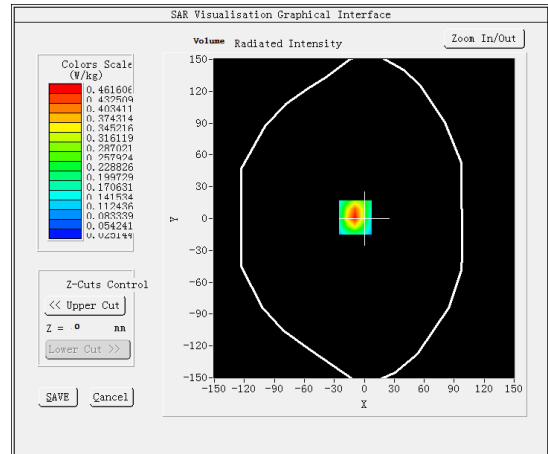

Maximum location: X=-9.00, Y=1.00 SAR Peak: 0.78 W/kg

SAR 10g (W/Kg)

0.219906

SAR 1g (W/Kg)

0.429674

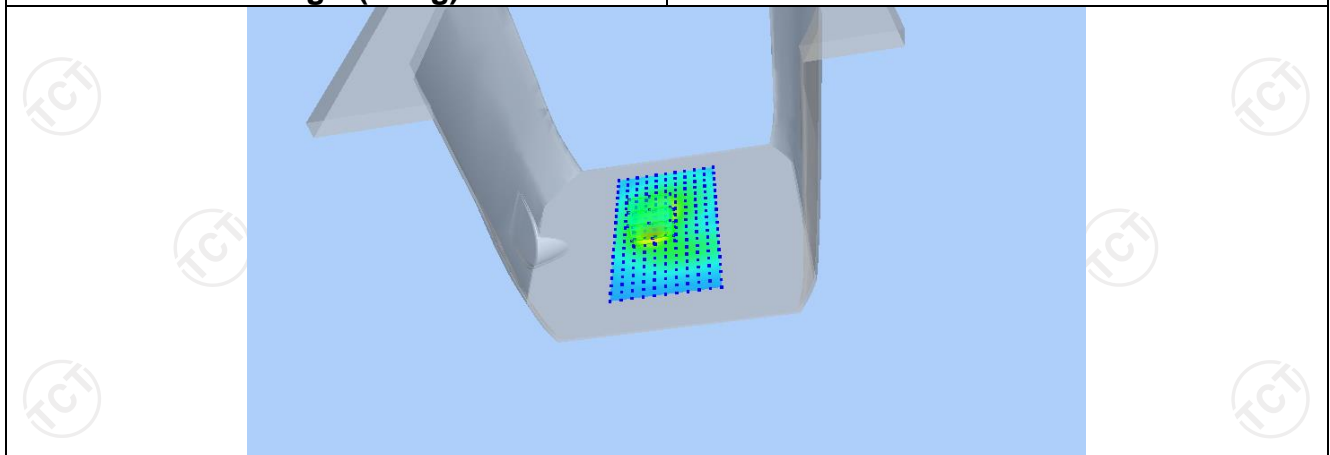

| | | | | | |
|-------------------|---------------|---------------|---------------|---------------|---------------|
| Z (mm) | 0.00 | 4.00 | 9.00 | 14.00 | 19.00 |
| SAR (W/Kg) | 0.7760 | 0.4616 | 0.2349 | 0.1256 | 0.0781 |

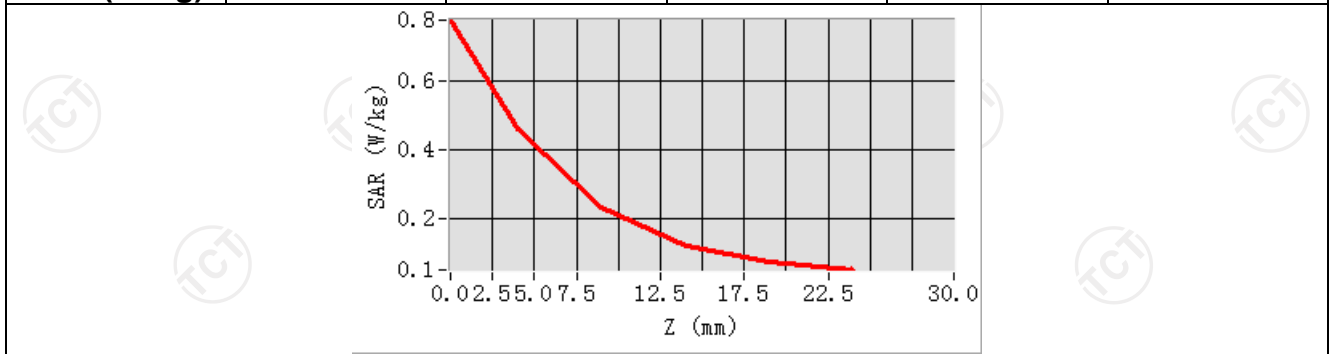

Hot spot position

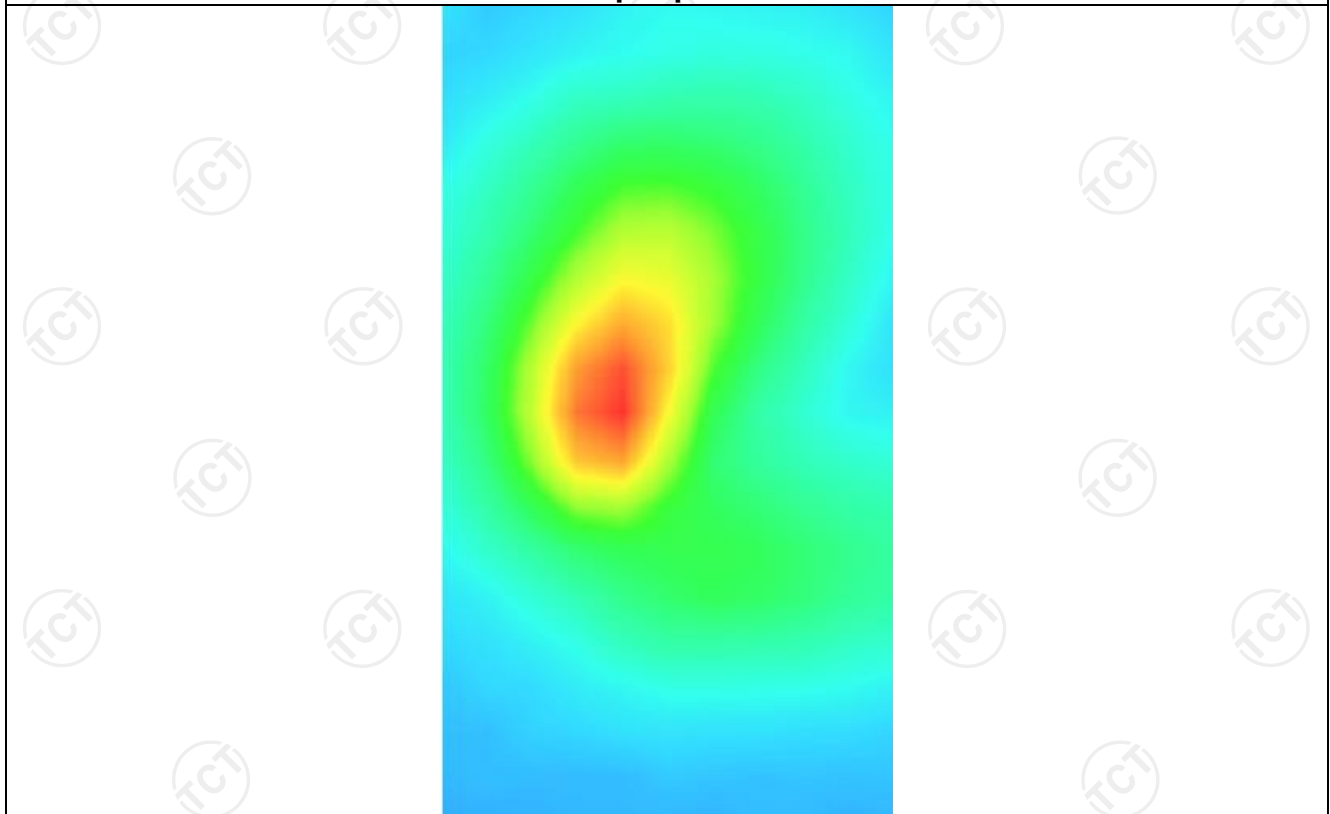

LTE Band 71

MEASUREMENT 1

Lower Band SAR (Channel 133222):

Date: 09/04/2023

| | |
|-----------------------------------------------|---------------------------------------------------------------------|
| Frequency (MHz) | 673.000000 |
| Relative permittivity (real part) | 42.126667 |
| Relative permittivity (imaginary part) | 23.264000 |
| Conductivity (S/m) | 0.914404 |
| Variation (%) | -3.530000 |
| Crest Factor | 1.0 |
| Probe Conversion factor | 4.36 |
| E-Field Probe: | SSE2 (SN 25/22 EPG0375) |
| Area Scan | dx=8mm dy=8mm, h= 5.00 mm |
| ZoomScan | 5x5x7, dx=8mm dy=8mm dz=5mm, Complete/ndx=8mm dy=8mm, h= 5.00 mm |
| Phantom | Validation plane |
| Device Position | Body back(0mm) |
| Band | <u>LTE band 71(50 RB#50)</u> |

SURFACE SAR

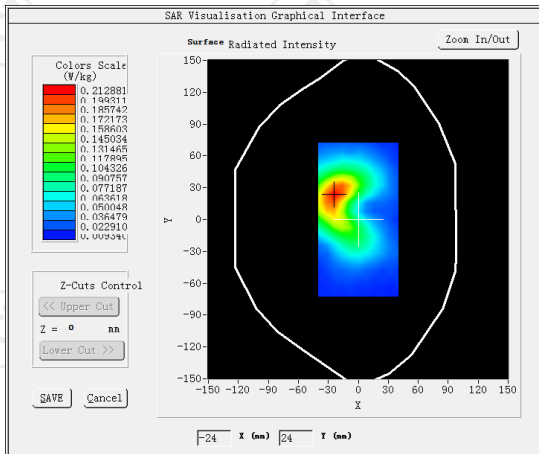

VOLUME SAR

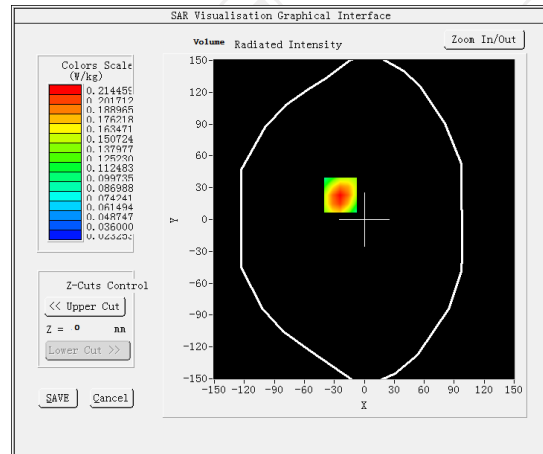

Maximum location: X=-24.00, Y=23.00 SAR Peak: 0.30 W/kg

| | |
|-----------------------|----------|
| SAR 10g (W/Kg) | 0.128515 |
| SAR 1g (W/Kg) | 0.203815 |

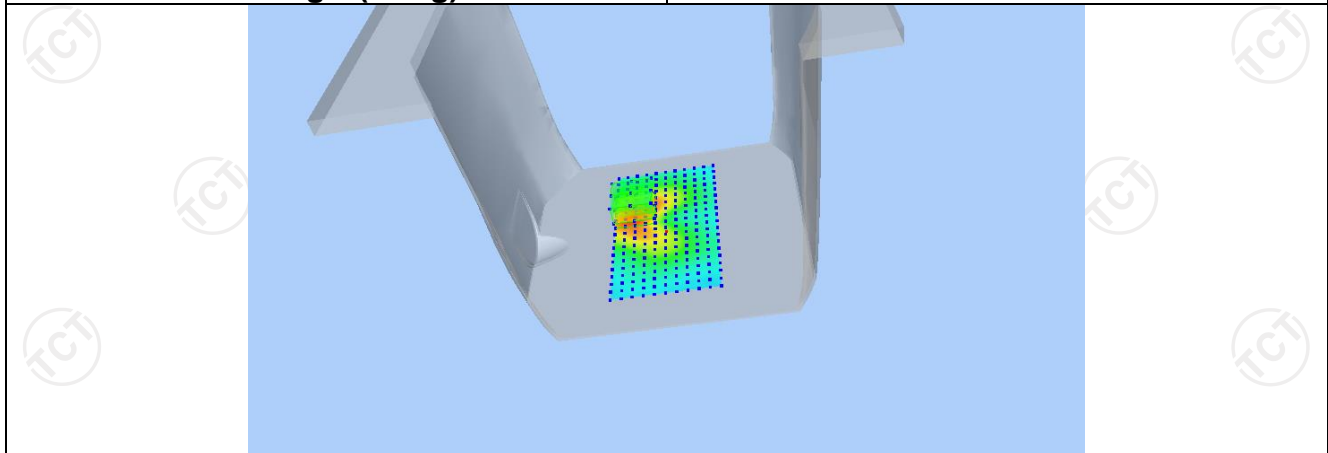

| | | | | | |
|-------------------|---------------|---------------|---------------|---------------|---------------|
| Z (mm) | 0.00 | 4.00 | 9.00 | 14.00 | 19.00 |
| SAR (W/Kg) | 0.3017 | 0.2145 | 0.1399 | 0.0936 | 0.0655 |

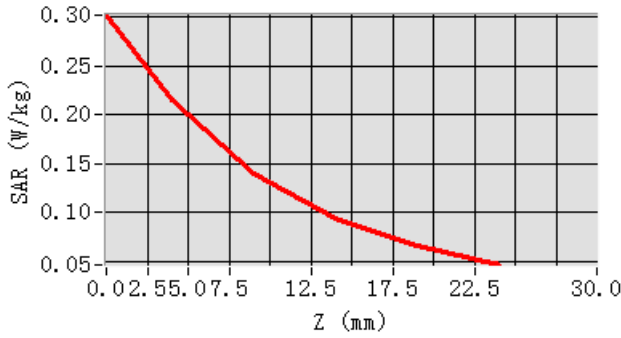

Hot spot position

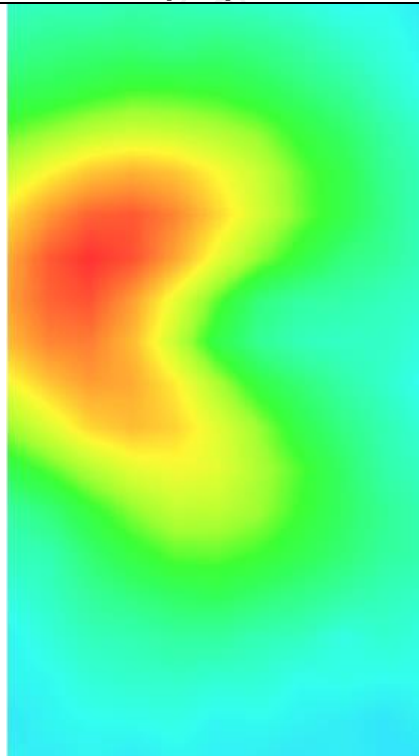

MEASUREMENT 2

Lower Band SAR (Channel 133222):

Date: 09/04/2023

| | |
|----------------------------------------|---------------------------------------------------------------------------------------------|
| Frequency (MHz) | 673.000000 |
| Relative permittivity (real part) | 42.126667 |
| Relative permittivity (imaginary part) | 23.264000 |
| Conductivity (S/m) | 0.914404 |
| Variation (%) | -1.610000 |
| Crest Factor | 1.0 |
| Probe Conversion factor | 4.36 |
| E-Field Probe: | SSE2 (SN 25/22 EPG0375) |
| Area Scan | <u>dx=8mm dy=8mm, h= 5.00 mm</u> |
| ZoomScan | <u>5x5x7, dx=8mm dy=8mm</u> <u>dz=5mm, Complete/ndx=8mm dy=8mm, h=</u> <u>5.00 mm</u> |
| Phantom | Validation plane |
| Device Position | Body back(hotspot 0mm) |
| Band | <u>LTE band 71(50 RB#50)</u> |

SURFACE SAR

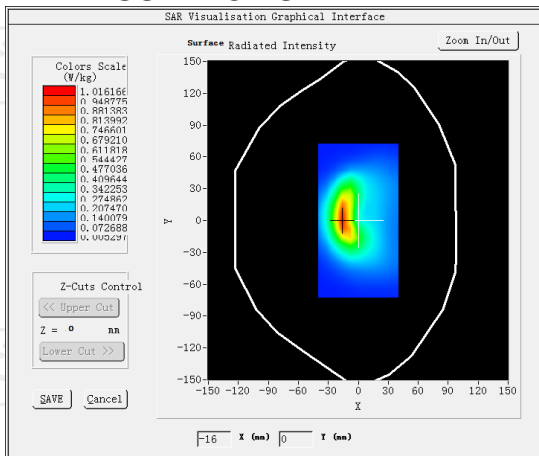

VOLUME SAR

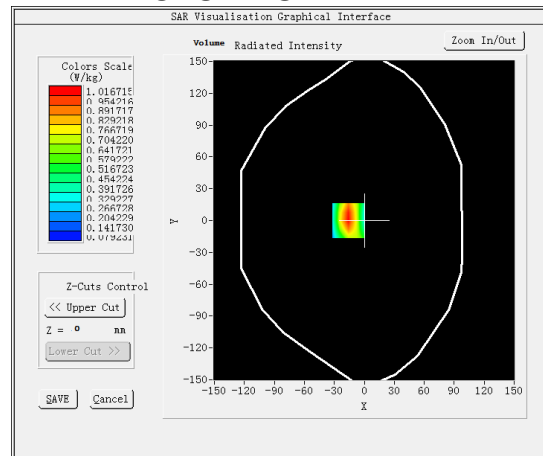

Maximum location: X=-16.00, Y=0.00 SAR Peak: 1.63 W/kg

SAR 10g (W/Kg)

0.528009

SAR 1g (W/Kg)

0.267987

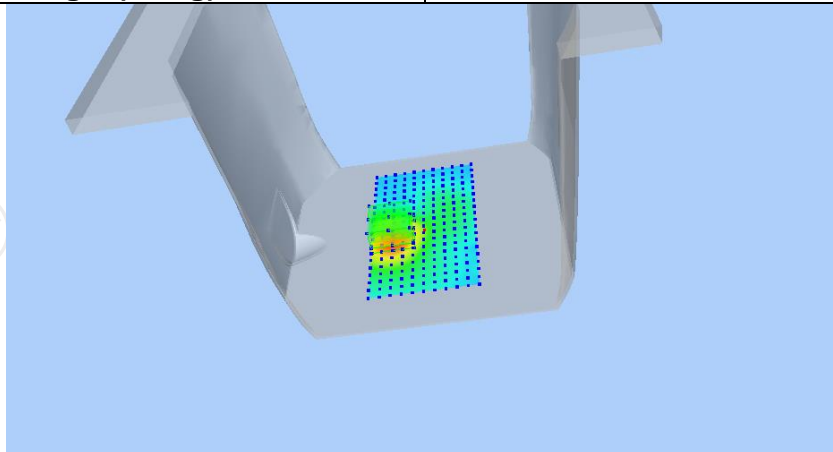

| | | | | | |
|-------------------|---------------|---------------|---------------|---------------|---------------|
| Z (mm) | 0.00 | 4.00 | 9.00 | 14.00 | 19.00 |
| SAR (W/Kg) | 1.6115 | 1.0167 | 0.5657 | 0.3309 | 0.2175 |

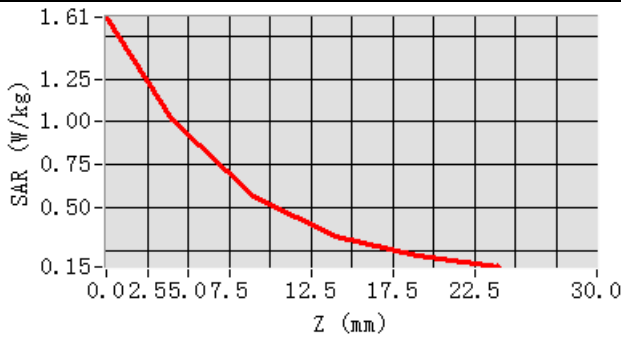

Hot spot position

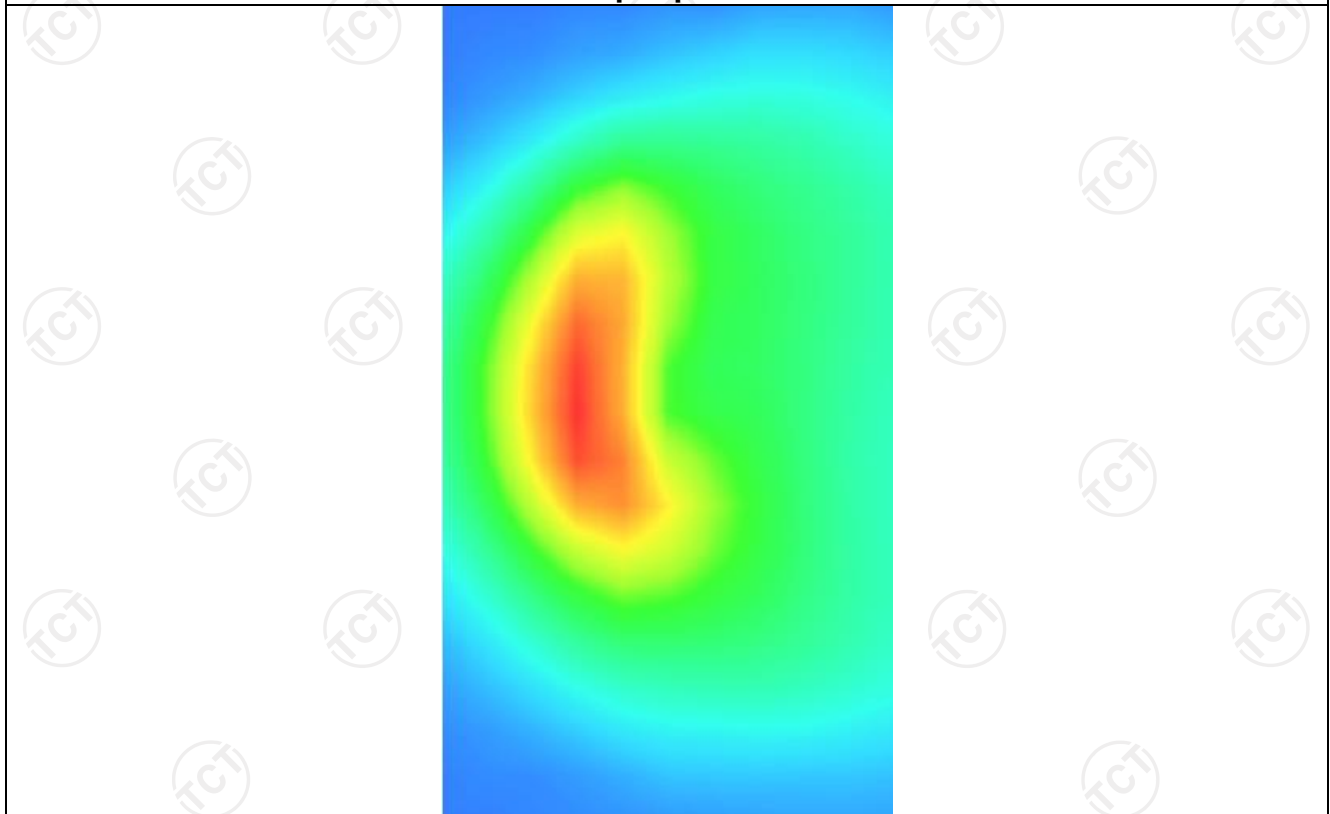

WLAN 2.4G

MEASUREMENT 1

High Band SAR (Channel 11):

Date: 09/08/2023

| | |
|-----------------------------------------------|-------------------------------------------------------------------------------------------|
| Frequency (MHz) | 2462.000000 |
| Relative permittivity (real part) | 39.226002 |
| Relative permittivity (imaginary part) | 13.207000 |
| Conductivity (S/m) | 1.788081 |
| Variation (%) | 3.570000 |
| Crest Factor | 1.0 |
| Probe Conversion factor | 2.31 |
| E-Field Probe: | SSE2 (SN 25/22 EPG0375) |
| Area Scan | <u>dx=8mm dy=8mm, h= 5.00 mm</u> |
| ZoomScan | <u>5x5x7,dx=8mm dy=8mm</u> <u>dz=5mm,Complete/ndx=8mm dy=8mm, h=</u> <u>5.00 mm</u> |
| Phantom | Validation plane |
| Device Position | Body back(0mm) |
| Band | <u>IEEE 802.11g ISM</u> |

SURFACE SAR

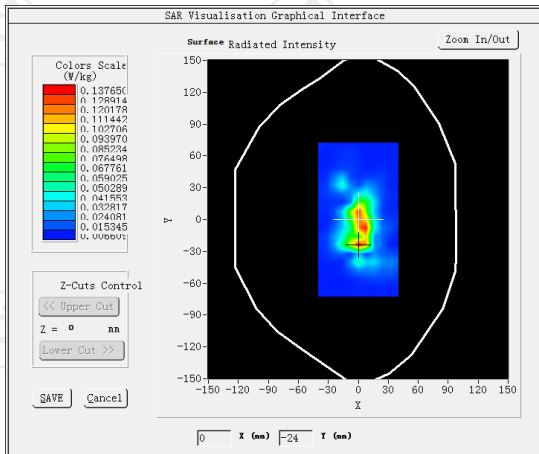

VOLUME SAR

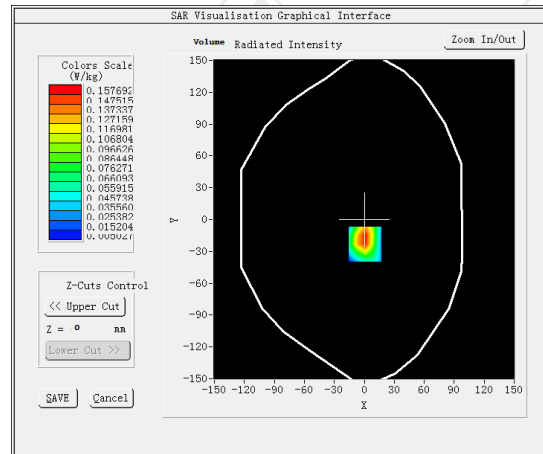

Maximum location: X=1.00, Y=23.00 SAR Peak: 0.34 W/kg

| | |
|-----------------------|----------|
| SAR 10g (W/Kg) | 0.065423 |
| SAR 1g (W/Kg) | 0.143691 |

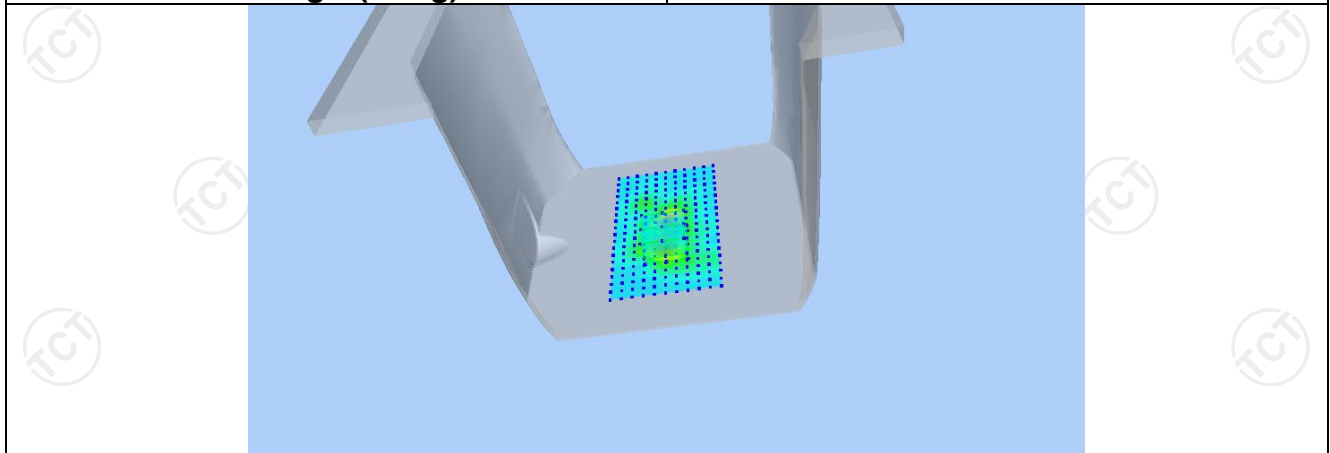

| | | | | | |
|-------------------|---------------|---------------|---------------|---------------|---------------|
| Z (mm) | 0.00 | 4.00 | 9.00 | 14.00 | 19.00 |
| SAR (W/Kg) | 0.4497 | 0.1577 | 0.0368 | 0.0175 | 0.0072 |

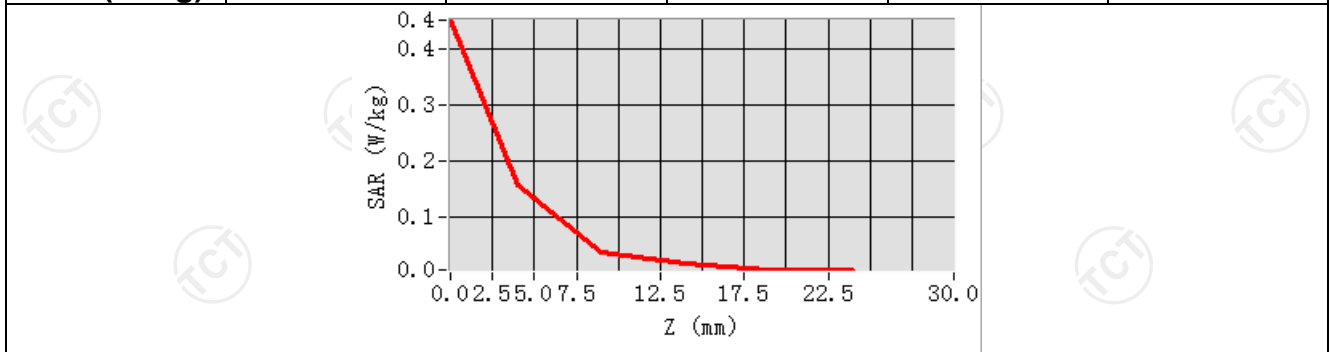

Hot spot position

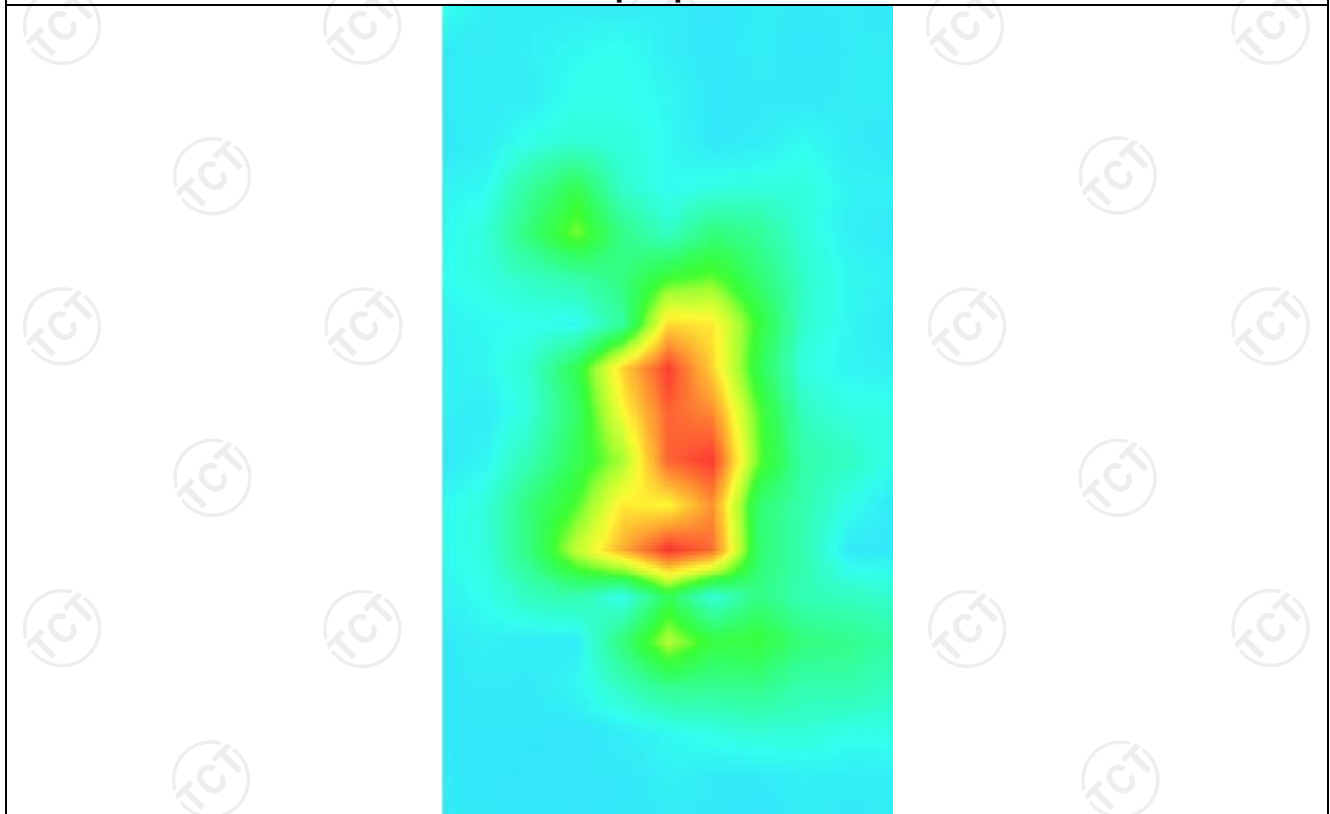

MEASUREMENT 2

High Band SAR (Channel 11):

Date: 09/08/2023

| | |
|----------------------------------------|-------------------------------------------------------------------------------------------|
| Frequency (MHz) | 2462.000000 |
| Relative permittivity (real part) | 39.226002 |
| Relative permittivity (imaginary part) | 13.207000 |
| Conductivity (S/m) | 1.788081 |
| Variation (%) | -3.130000 |
| Crest Factor | 1.0 |
| Probe Conversion factor | 2.31 |
| E-Field Probe: | SSE2 (SN 25/22 EPGO375) |
| Area Scan | <u>dx=8mm dy=8mm, h= 5.00 mm</u> |
| ZoomScan | <u>5x5x7,dx=8mm dy=8mm</u> <u>dz=5mm,Complete/ndx=8mm dy=8mm, h=</u> <u>5.00 mm</u> |
| Phantom | Validation plane |
| Device Position | Body back(0mm) |
| Band | <u>IEEE 802.11g ISM(hotspot)</u> |

SURFACE SAR

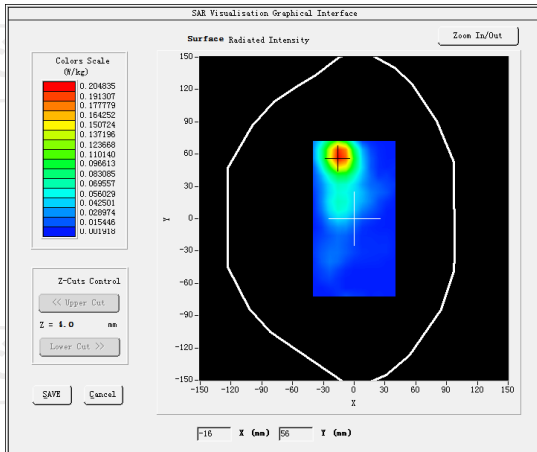

VOLUME SAR

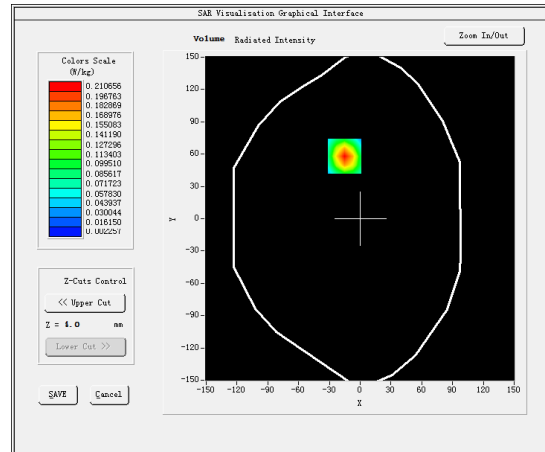

Maximum location: X=-15.00, Y=58.00 SAR Peak: 0.37 W/kg

SAR 10g (W/Kg)

0.087182

SAR 1g (W/Kg)

0.213788

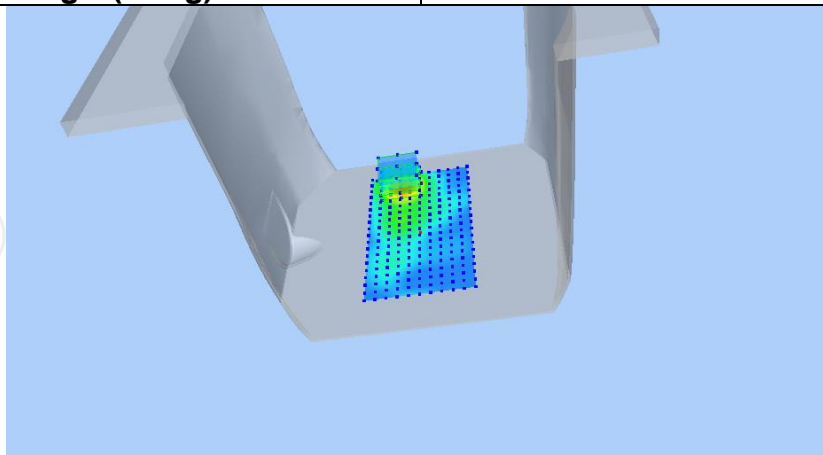

| | | | | | |
|-------------------|---------------|---------------|---------------|---------------|---------------|
| Z (mm) | 0.00 | 4.00 | 9.00 | 14.00 | 19.00 |
| SAR (W/Kg) | 0.3732 | 0.2107 | 0.0935 | 0.0368 | 0.0124 |

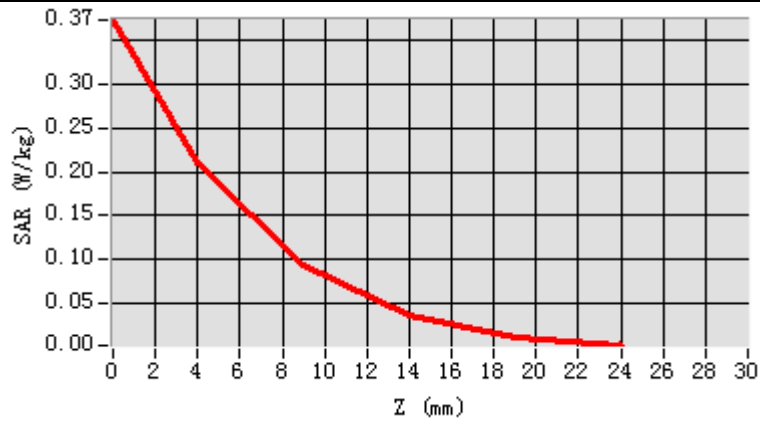

Hot spot position

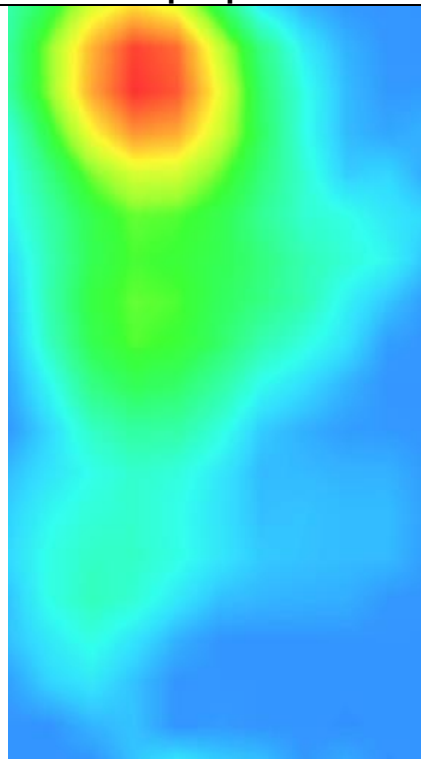

WLAN 5.2G

MEASUREMENT 1

SAR (Channel 48):

Date: 09/11/2023

| | |
|----------------------------------------|---------------------------------------------------------------------|
| Frequency (MHz) | 5240.000000 |
| Relative permittivity (real part) | 35.068832 |
| Relative permittivity (imaginary part) | 13.679428 |
| Conductivity (S/m) | 5.220788 |
| Variation (%) | -2.510000 |
| Crest Factor | 1.0 |
| Probe Conversion factor | 2.01 |
| E-Field Probe: | SSE2 (SN 25/22 EPG0375) |
| Area Scan | dx=8mm dy=8mm, h= 5.00 mm |
| ZoomScan | 5x5x7, dx=8mm dy=8mm dz=5mm, Complete/ndx=8mm dy=8mm, h= 5.00 mm |
| Phantom | Validation plane |
| Device Position | Body back(0mm) |
| Band | IEEE 802.11ac VHT20 |

SURFACE SAR

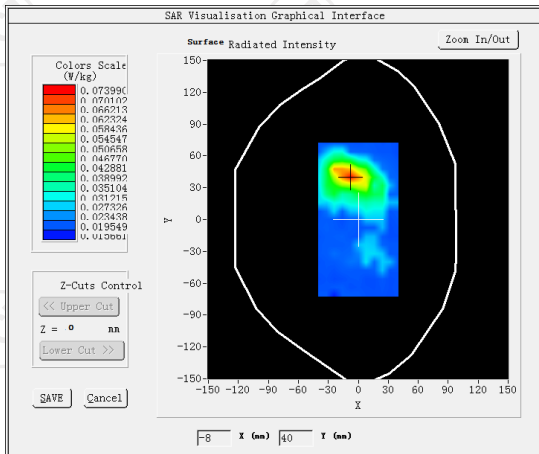

VOLUME SAR

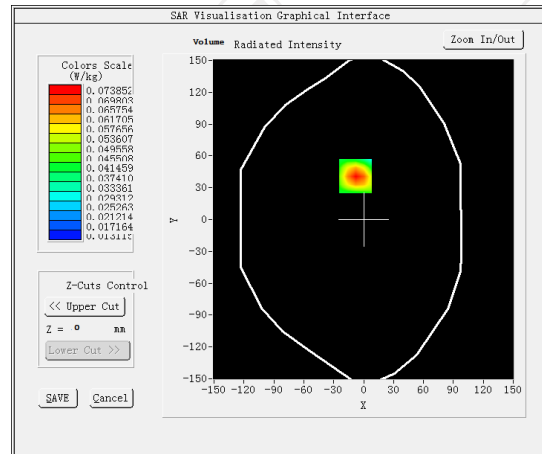

Maximum location: X=16.00, Y=63.00 SAR Peak: 0.10 W/kg

| | |
|----------------|----------|
| SAR 10g (W/Kg) | 0.140642 |
| SAR 1g (W/Kg) | 0.238531 |

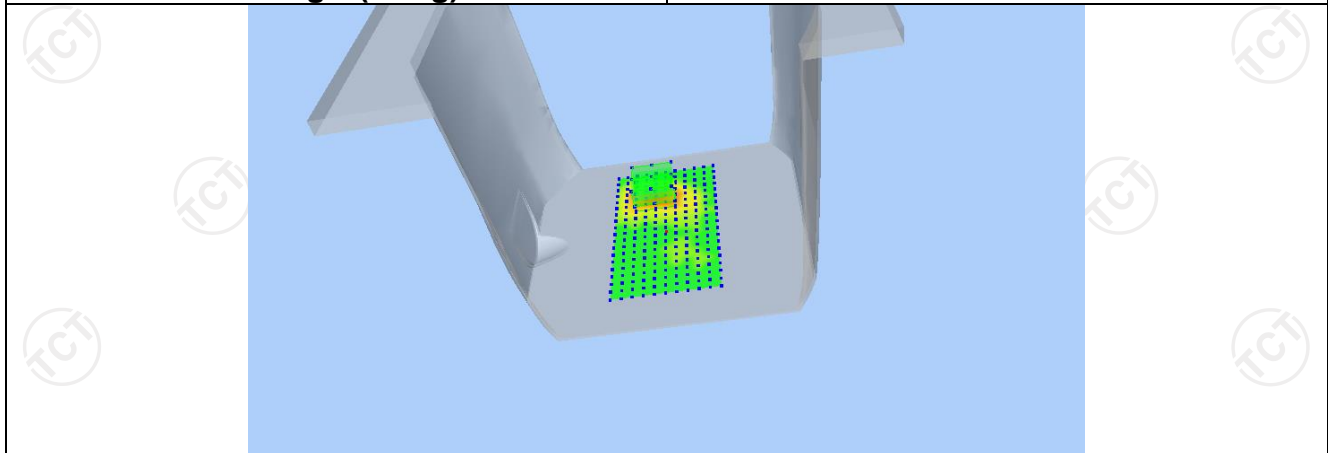

| | | | | | |
|------------|--------|--------|--------|--------|--------|
| Z (mm) | 0.00 | 4.00 | 9.00 | 14.00 | 19.00 |
| SAR (W/Kg) | 0.3372 | 0.1876 | 0.0816 | 0.0317 | 0.0109 |

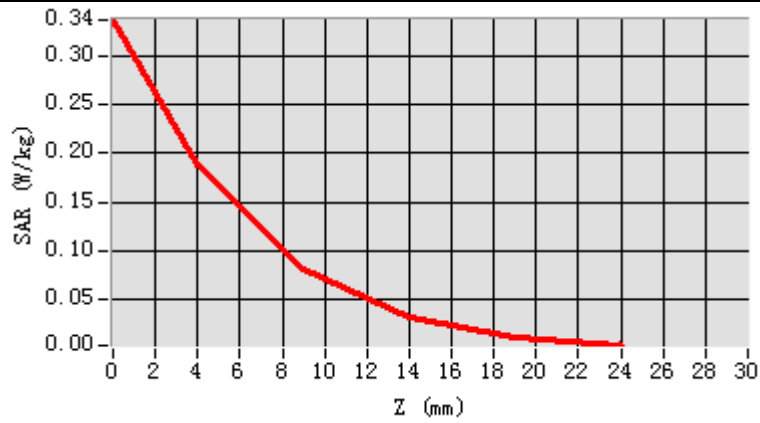

Hot spot position

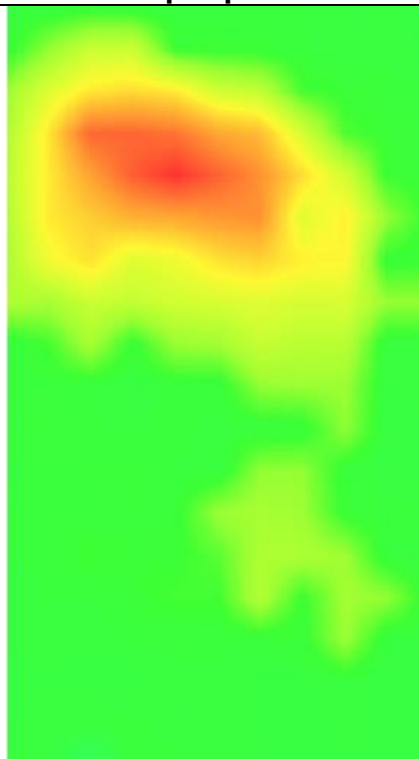

MEASUREMENT 2

SAR (Channel 48):

Date: 09/11/2023

| | |
|----------------------------------------|---------------------------------------------------------------------------------------------|
| Frequency (MHz) | 5240.000000 |
| Relative permittivity (real part) | 35.068832 |
| Relative permittivity (imaginary part) | 13.679428 |
| Conductivity (S/m) | 5.220788 |
| Variation (%) | -1.640000 |
| Crest Factor | 1.0 |
| Probe Conversion factor | 2.01 |
| E-Field Probe: | SSE2 (SN 25/22 EPG0375) |
| Area Scan | <u>dx=8mm dy=8mm, h= 5.00 mm</u> |
| ZoomScan | <u>5x5x7, dx=8mm dy=8mm</u> <u>dz=5mm, Complete/ndx=8mm dy=8mm, h=</u> <u>5.00 mm</u> |
| Phantom | Validation plane |
| Device Position | Body back(hotspot 0mm) |
| Band | IEEE 802.11ac VHT20 |

SURFACE SAR

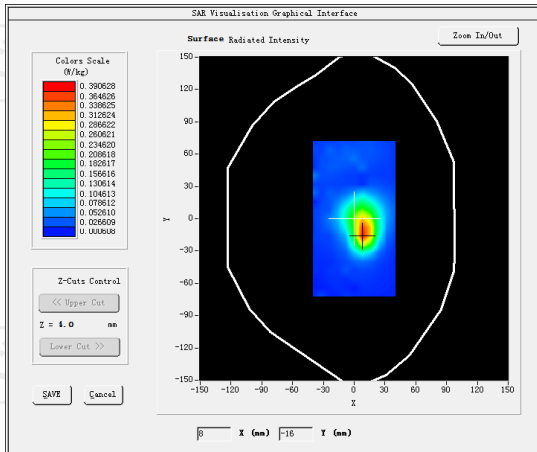

VOLUME SAR

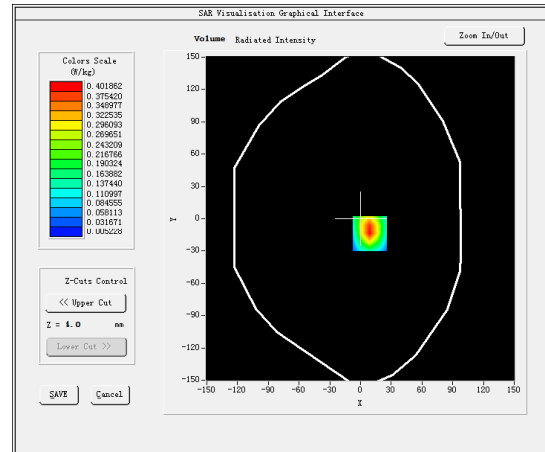

Maximum location: X=19.00, Y=-12.00 SAR Peak: 0.70 W/kg

SAR 10g (W/Kg)

0.274213

SAR 1g (W/Kg)

0.301152

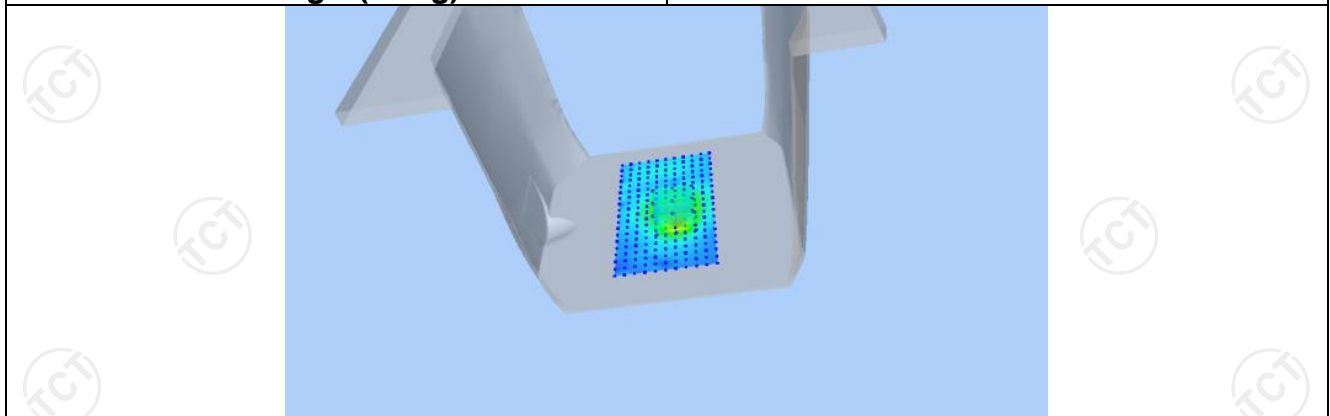

| | | | | | |
|-------------------|---------------|---------------|---------------|---------------|---------------|
| Z (mm) | 0.00 | 4.00 | 9.00 | 14.00 | 19.00 |
| SAR (W/Kg) | 0.7042 | 0.4012 | 0.1842 | 0.0710 | 0.0314 |

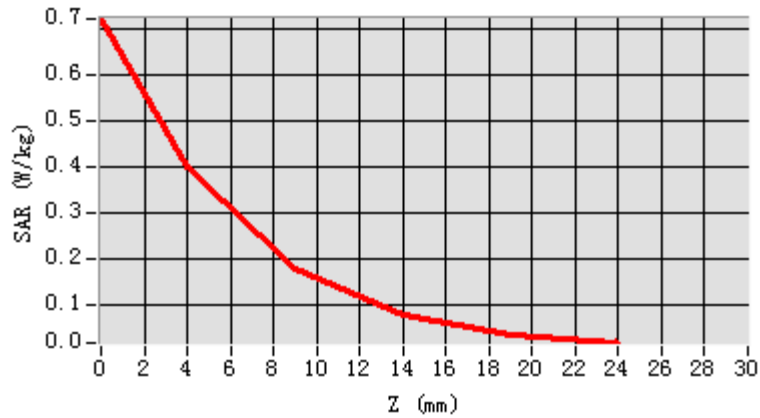

Hot spot position

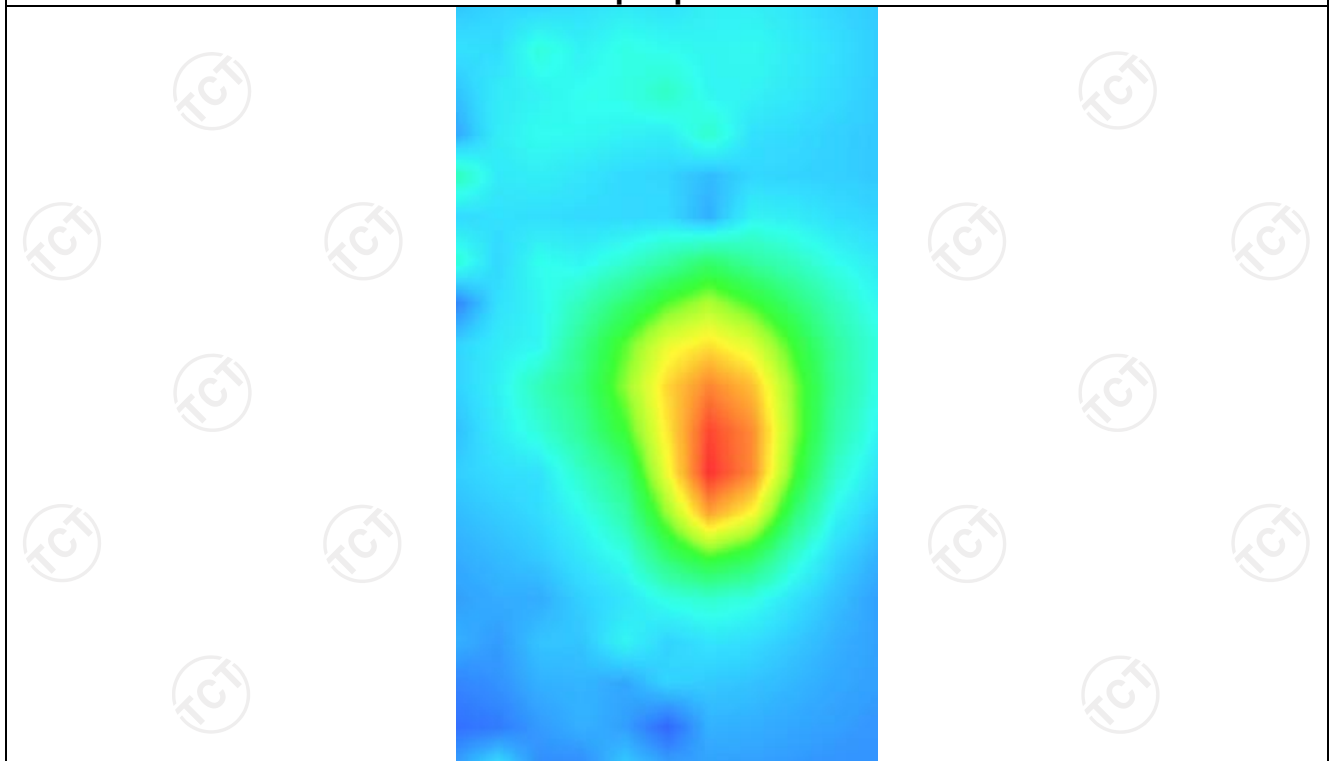

WLAN 5.8G

MEASUREMENT 1

SAR (Channel 149):

Date: 09/11/2023

| | |
|-----------------------------------------------|---------------------------------------------------------------------------------------------|
| Frequency (MHz) | 5785.000000 |
| Relative permittivity (real part) | 38.352823 |
| Relative permittivity (imaginary part) | 13.671675 |
| Conductivity (S/m) | 5.430828 |
| Variation (%) | -1.450000 |
| Crest Factor | 1.0 |
| Probe Conversion factor | 2.13 |
| E-Field Probe: | SSE2 (SN 25/22 EPG0375) |
| Area Scan | <u>dx=8mm dy=8mm, h= 5.00 mm</u> |
| ZoomScan | <u>5x5x7, dx=8mm dy=8mm</u> <u>dz=5mm, Complete/ndx=8mm dy=8mm, h=</u> <u>5.00 mm</u> |
| Phantom | Validation plane |
| Device Position | Body back(0mm) |
| Band | <u>IEEE 802.11ac VHT20</u> |

SURFACE SAR

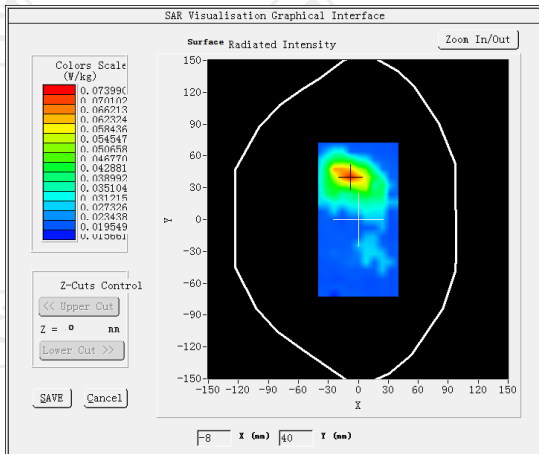

VOLUME SAR

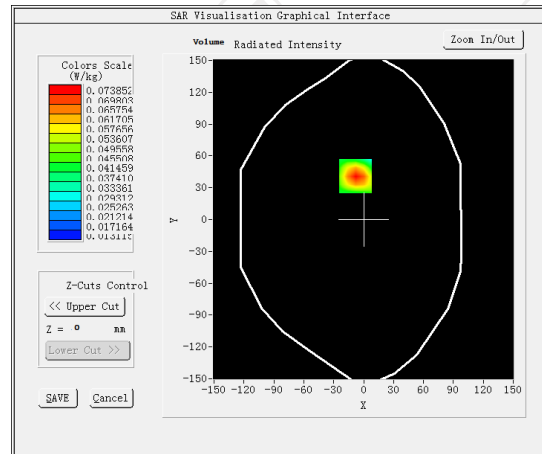

Maximum location: X=15.00, Y=60.00 SAR Peak: 0.34 W/kg

SAR 10g (W/Kg)

0.151431

SAR 1g (W/Kg)

0.215420

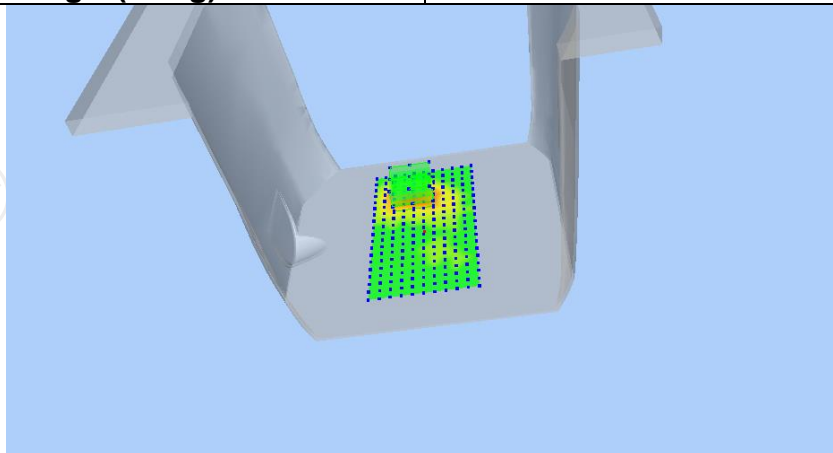

| | | | | | |
|-------------------|---------------|---------------|---------------|---------------|---------------|
| Z (mm) | 0.00 | 4.00 | 9.00 | 14.00 | 19.00 |
| SAR (W/Kg) | 0.3397 | 0.1890 | 0.0823 | 0.0317 | 0.0117 |

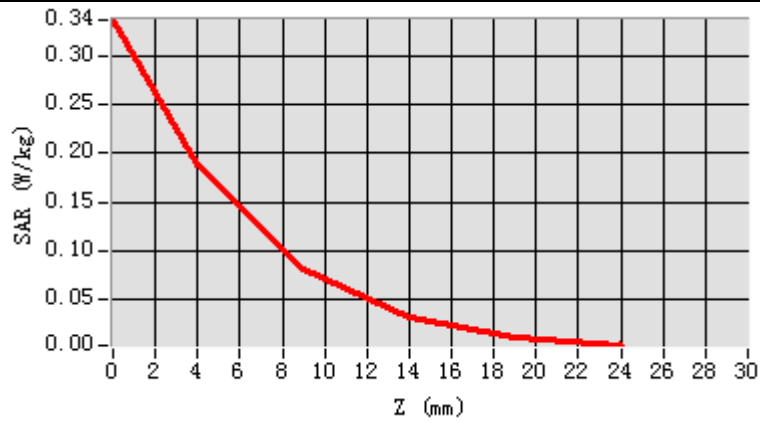

Hot spot position

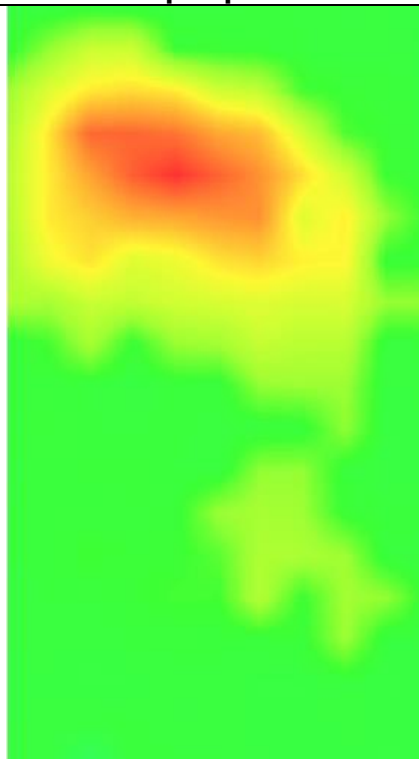

MEASUREMENT 2

SAR (Channel 149):

Date: 09/11/2023

| | |
|----------------------------------------|-------------------------------------------------------------------------------------------|
| Frequency (MHz) | 5785.000000 |
| Relative permittivity (real part) | 38.352823 |
| Relative permittivity (imaginary part) | 13.671675 |
| Conductivity (S/m) | 5.430828 |
| Variation (%) | -3.520000 |
| Crest Factor | 1.0 |
| Probe Conversion factor | 2.13 |
| E-Field Probe: | SSE2 (SN 25/22 EPGO375) |
| Area Scan | <u>dx=8mm dy=8mm, h= 5.00 mm</u> |
| ZoomScan | <u>5x5x7,dx=8mm dy=8mm</u> <u>dz=5mm,Complete/ndx=8mm dy=8mm, h=</u> <u>5.00 mm</u> |
| Phantom | <u>Validation plane</u> |
| Device Position | <u>Body back(0mm)</u> |
| Band | <u>IEEE 802.11a ISM(hotspot)</u> |

SURFACE SAR

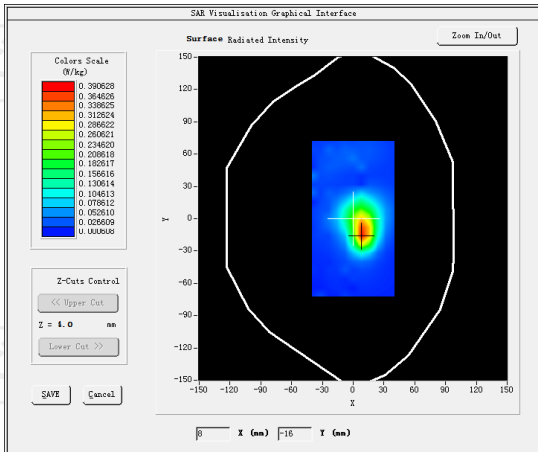

VOLUME SAR

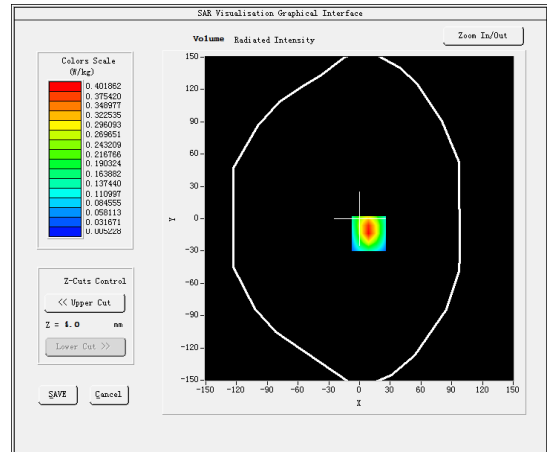

Maximum location: X=19.00, Y=-12.00 SAR Peak: 0.70 W/kg

SAR 10g (W/Kg)

0.163397

SAR 1g (W/Kg)

0.272473

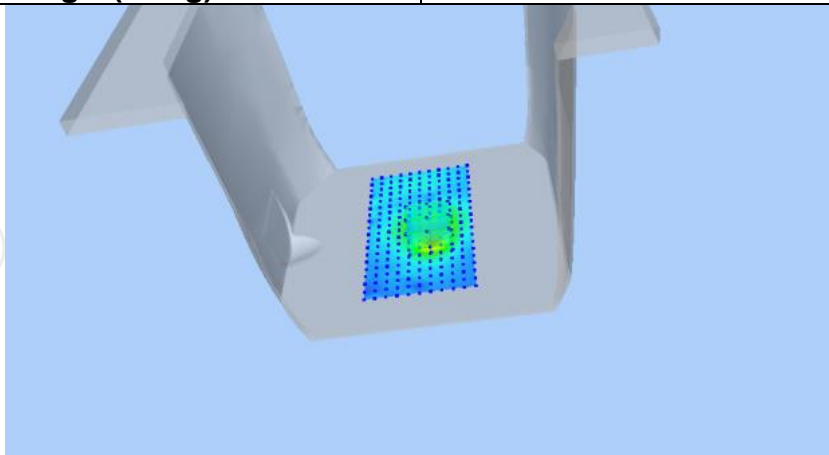

| | | | | | |
|-------------------|---------------|---------------|---------------|---------------|---------------|
| Z (mm) | 0.00 | 4.00 | 9.00 | 14.00 | 19.00 |
| SAR (W/Kg) | 0.7032 | 0.4014 | 0.1808 | 0.0734 | 0.0402 |

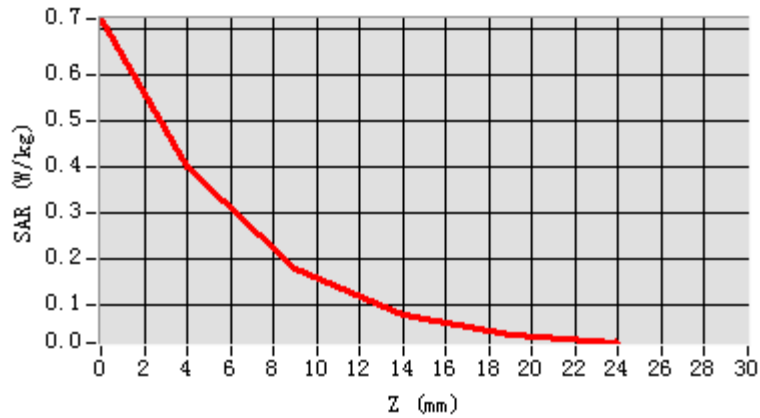

Hot spot position

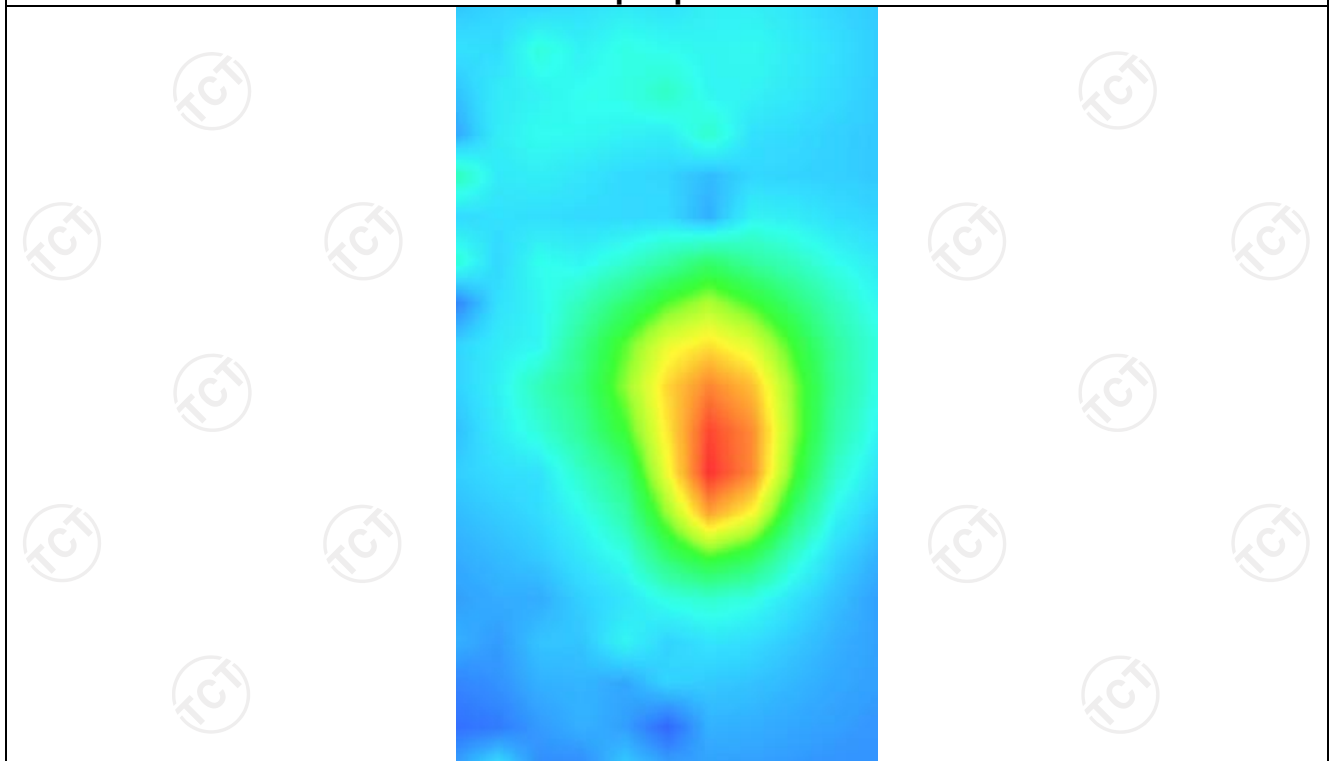

BT

MEASUREMENT 1

High Band SAR (Channel 79):

Date: 09/08/2023

| | |
|-----------------------------------------------|-------------------------------------------------------------------------------------------|
| Frequency (MHz) | 2480.000000 |
| Relative permittivity (real part) | 39.217999 |
| Relative permittivity (imaginary part) | 13.211000 |
| Conductivity (S/m) | 1.791558 |
| Variation (%) | 2.570000 |
| Crest Factor | 1.0 |
| Probe Conversion factor | 2.31 |
| E-Field Probe: | SSE2 (SN 25/22 EPG0375) |
| Area Scan | <u>dx=8mm dy=8mm, h= 5.00 mm</u> |
| ZoomScan | <u>5x5x7,dx=8mm dy=8mm</u> <u>dz=5mm,Complete/ndx=8mm dy=8mm, h=</u> <u>5.00 mm</u> |
| Phantom | Validation plane |
| Device Position | Body back(0mm) |
| Band | <u>8DPSK</u> |

SURFACE SAR

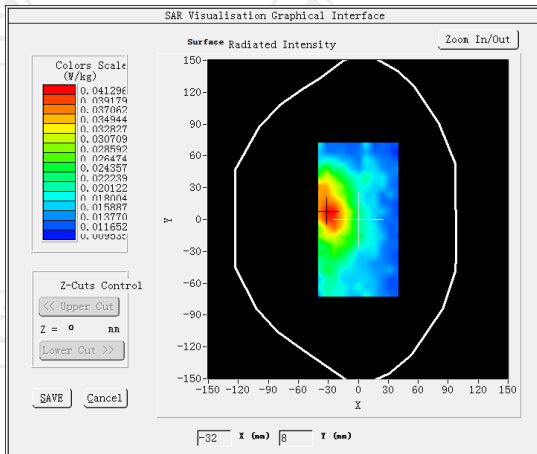

VOLUME SAR

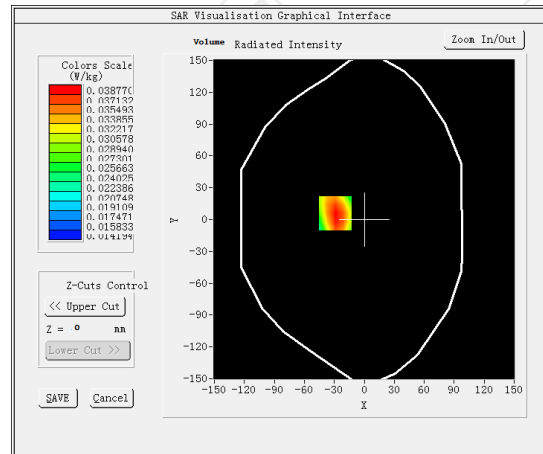

Maximum location: X=-29.00, Y=6.00 SAR Peak: 0.05 W/kg

SAR 10g (W/Kg)

0.028107

SAR 1g (W/Kg)

0.037717

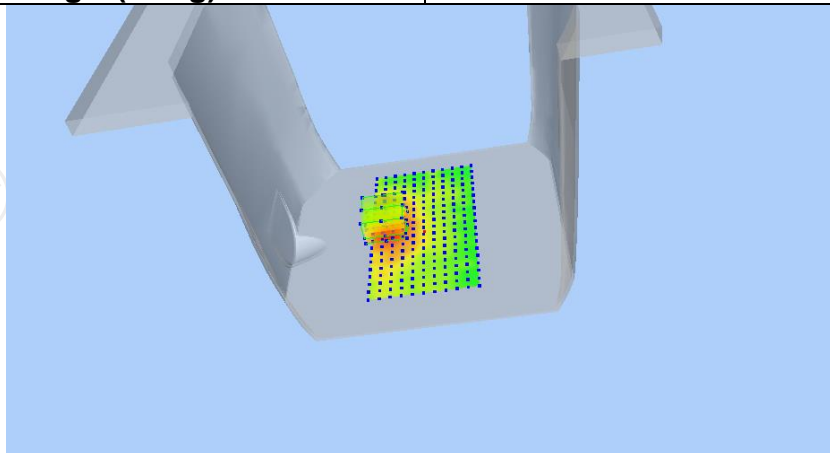

| | | | | | |
|-------------------|---------------|---------------|---------------|---------------|---------------|
| Z (mm) | 0.00 | 4.00 | 9.00 | 14.00 | 19.00 |
| SAR (W/Kg) | 0.0515 | 0.0388 | 0.0280 | 0.0215 | 0.0180 |

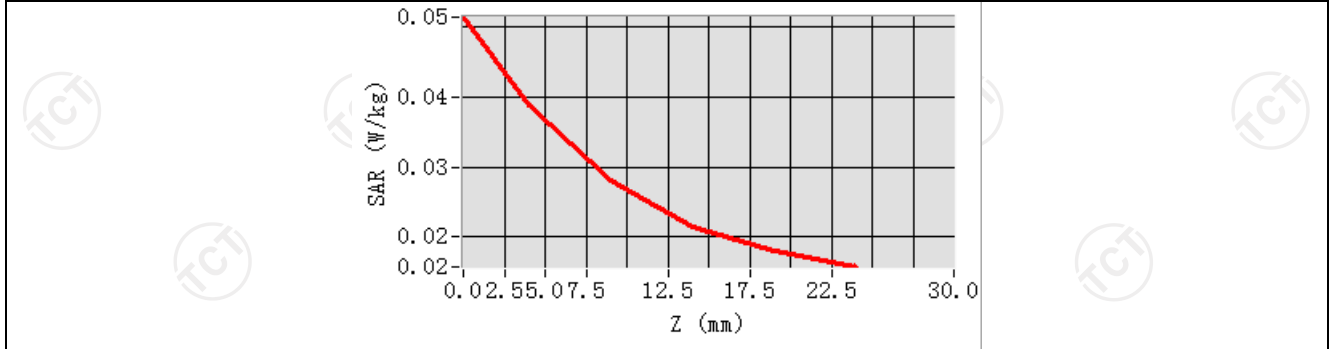

Hot spot position

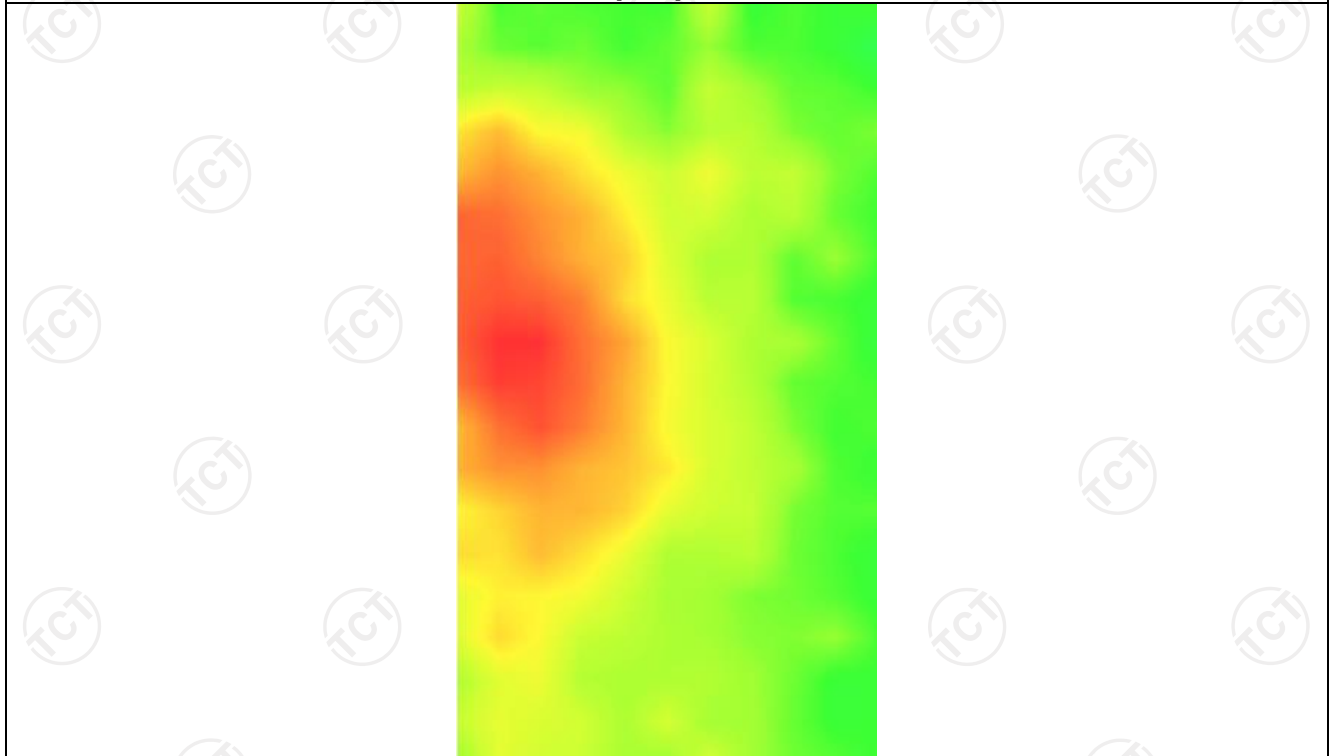

Appendix A: EUT Photos

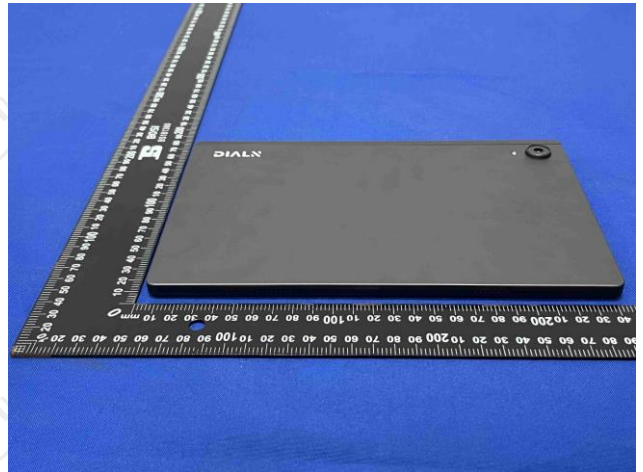
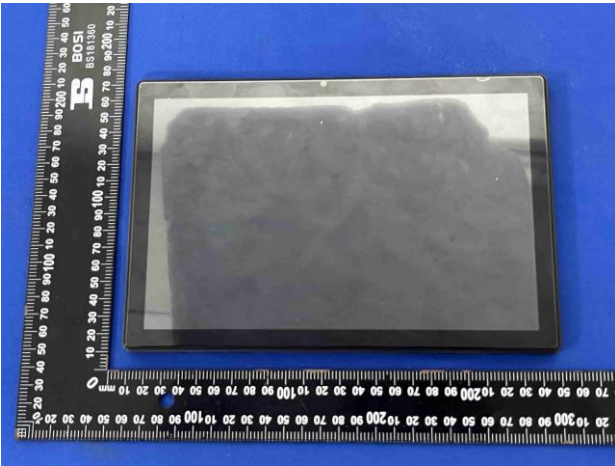

Liquid depth



The Body Liquid of 835MHz (15.4cm)



The Body Liquid of 1800MHz (15.2 cm)



The Body Liquid of 1900MHz (16.4 cm)



The Body Liquid of 2450MHz (15.3cm)



The Body Liquid of 2600MHz (16.5cm)



The Body Liquid of 5000-6000MHz (16.5cm)



The Body Liquid of 750MHz (15.4cm)



The Head Liquid of 1900MHz (15.5cm)



The Head Liquid of 2450MHz (15.6cm)

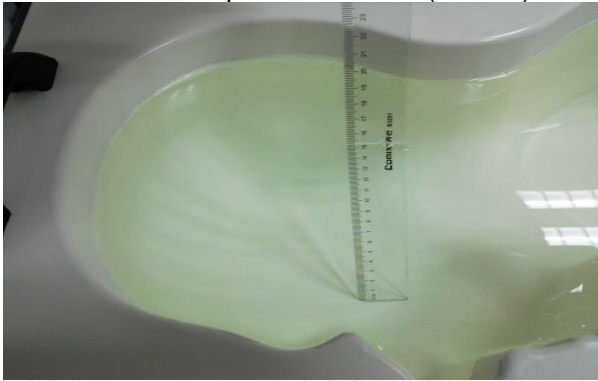

The Head Liquid of 835MHz (15.3cm)

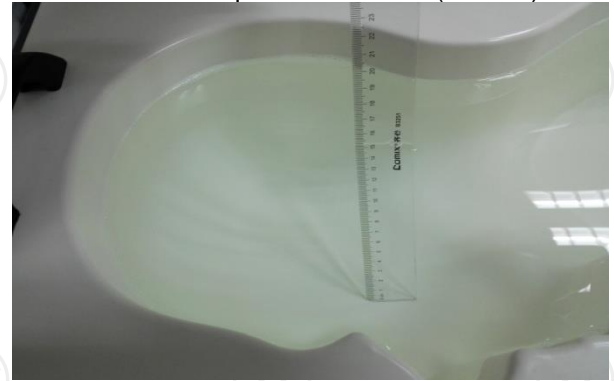

The Head Liquid of 1800MHz (15.2cm)

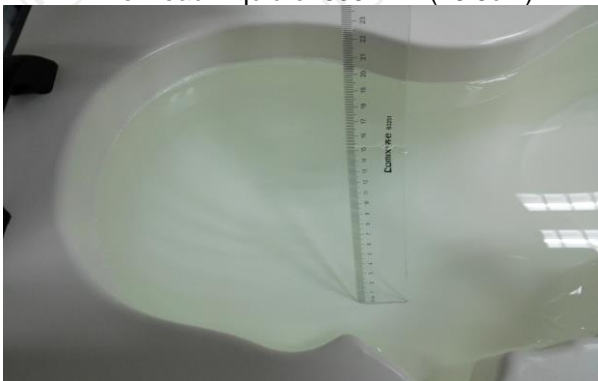

The Head Liquid of 2600MHz (15.1cm)

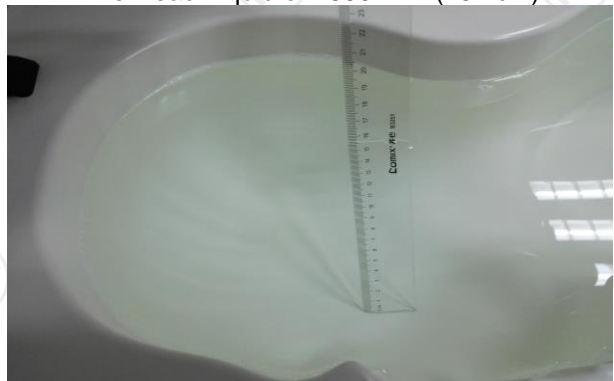

The Body Liquid of 5000-6000MHz (15.8cm)

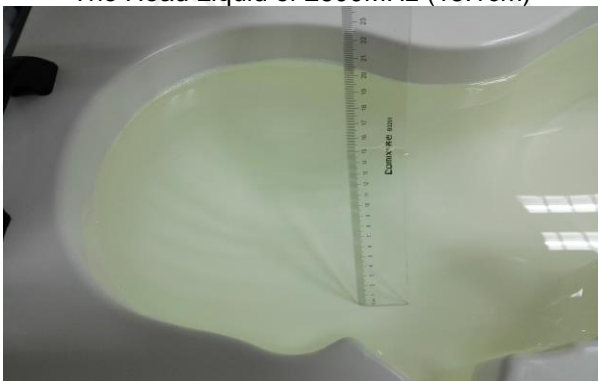

The Head Liquid of 750MHz (15.4cm)

Appendix B: Test Setup Photos



Body worn – Front (0mm)



Body worn – Back (0mm)



Body worn – Top (0mm)



Hotspo Front (0mm)



Hotspo Back (0mm)



Hotspot Top (0mm)

Appendix C: Probe Calibration Certificate

COMOSAR E-FIELD Probe



COMOSAR E-Field Probe Calibration Report

Ref : ACR.180.7.22.BES.B

SHENZHEN TONGCE TESTING LAB
2101 & 2201, ZHENCHANG FACTORY RENSHAN INDUSTRIAL
ZONE, FUHAI SUBDISTRICT, BAO'AN DISTRICT SHENZHEN,
GUANGDONG, 518103, PEOPLE'S REPUBLIC OF CHINA
MVG COMOSAR DOSIMETRIC E-FIELD PROBE
SERIAL NO.: SN 25/22 EPGO375

Calibrated at MVG
Z.I. de la pointe du diable
Technopôle Brest Iroise – 295 avenue Alexis de Rochon
29280 PLOUZANE - FRANCE

Calibration date: 06/29/2023



Accreditations #2-6789
Scope available on www.cofrac.fr

The use of the Cofrac brand and the accreditation references is prohibited from any reproduction.

Summary:

This document presents the method and results from an accredited COMOSAR Dosimetric E-Field Probe calibration performed at MVG, using the CALIPROBE test bench, for use with a MVG COMOSAR system only. The test results covered by accreditation are traceable to the International System of Units (SI).



COMOSAR E-FIELD PROBE CALIBRATION REPORT

Ref: ACR.180.7.22.BES.B

| | <i>Name</i> | <i>Function</i> | <i>Date</i> | <i>Signature</i> |
|-----------------------------------|----------------|-------------------------|-------------|------------------|
| <i>Prepared by :</i> | Jérôme Le Gall | Measurement Responsible | 6/30/2023 | |
| <i>Checked & approved by:</i> | Jérôme Luc | Technical Manager | 6/30/2023 | |
| <i>Authorized by:</i> | Yann Toutain | Laboratory Director | 7/05/2023 | |

| | <i>Customer Name</i> |
|-----------------------|-----------------------------|
| <i>Distribution :</i> | Shenzhen Tongce Testing Lab |

| <i>Issue</i> | <i>Name</i> | <i>Date</i> | <i>Modifications</i> |
|--------------|----------------|-------------|----------------------|
| A | Jérôme Le Gall | 6/30/2023 | Initial release |
| | | | |
| | | | |



TABLE OF CONTENTS

| | | |
|-----|---------------------------------------|----|
| 1 | Device Under Test | 4 |
| 2 | Product Description | 4 |
| 2.1 | General Information | 4 |
| 3 | Measurement Method | 4 |
| 3.1 | Linearity | 4 |
| 3.2 | Sensitivity | 4 |
| 3.3 | Lower Detection Limit | 5 |
| 3.4 | Isotropy | 5 |
| 3.1 | Boundary Effect | 5 |
| 4 | Measurement Uncertainty | 6 |
| 5 | Calibration Measurement Results | 6 |
| 5.1 | Sensitivity in air | 6 |
| 5.2 | Linearity | 7 |
| 5.3 | Sensitivity in liquid | 8 |
| 5.4 | Isotropy | 9 |
| 6 | List of Equipment | 10 |



1 DEVICE UNDER TEST

| Device Under Test | |
|------------------------------------------|-------------------------------------------------------------------------|
| Device Type | COMOSAR DOSIMETRIC E FIELD PROBE |
| Manufacturer | MVG |
| Model | SSE2 |
| Serial Number | SN 25/22 EPGO375 |
| Product Condition (new / used) | New |
| Frequency Range of Probe | 0.15 GHz-6GHz |
| Resistance of Three Dipoles at Connector | Dipole 1: R1=0.197 MΩ Dipole 2: R2=0.230 MΩ Dipole 3: R3=0.208 MΩ |

2 PRODUCT DESCRIPTION

2.1 GENERAL INFORMATION

MVG’s COMOSAR E field Probes are built in accordance to the IEC/IEEE 62209-1528 and FCC KDB865664 D01 standards.



Figure 1 – MVG COMOSAR Dosimetric E field Probe

| | |
|--------------------------------------------|--------|
| Probe Length | 330 mm |
| Length of Individual Dipoles | 2 mm |
| Maximum external diameter | 8 mm |
| Probe Tip External Diameter | 2.5 mm |
| Distance between dipoles / probe extremity | 1 mm |

3 MEASUREMENT METHOD

The IEC/IEEE 62209-1528 and FCC KDB865664 D01 standards provide recommended practices for the probe calibrations, including the performance characteristics of interest and methods by which to assess their affect. All calibrations / measurements performed meet the fore mentioned standards.

3.1 LINEARITY

The evaluation of the linearity was done in free space using the waveguide, performing a power sweep to cover the SAR range 0.01W/kg to 100W/kg.

3.2 SENSITIVITY

The sensitivity factors of the three dipoles were determined using a two step calibration method (air and tissue simulating liquid) using waveguides as outlined in the standards.

Page: 4/11

Template_ACR.DDD.N.YY.MVGB.ISSUE_COMOSAR Probe vK

This document shall not be reproduced, except in full or in part, without the written approval of MVG. The information contained herein is to be used only for the purpose for which it is submitted and is not to be released in whole or part without written approval of MVG.



3.3 LOWER DETECTION LIMIT

The lower detection limit was assessed using the same measurement set up as used for the linearity measurement. The required lower detection limit is 10 mW/kg.

3.4 ISOTROPY

The axial isotropy was evaluated by exposing the probe to a reference wave from a standard dipole with the dipole mounted under the flat phantom in the test configuration suggested for system validations and checks. The probe was rotated along its main axis from 0 to 360 degrees in 15-degree steps. The hemispherical isotropy is determined by inserting the probe in a thin plastic box filled with tissue-equivalent liquid, with the plastic box illuminated with the fields from a half wave dipole. The dipole is rotated about its axis (0°–180°) in 15° increments. At each step the probe is rotated about its axis (0°–360°).

3.1 BOUNDARY EFFECT

The boundary effect is defined as the deviation between the SAR measured data and the expected exponential decay in the liquid when the probe is oriented normal to the interface. To evaluate this effect, the liquid filled flat phantom is exposed to fields from either a reference dipole or waveguide. With the probe normal to the phantom surface, the peak spatial average SAR is measured and compared to the analytical value at the surface.

The boundary effect uncertainty can be estimated according to the following uncertainty approximation formula based on linear and exponential extrapolations between the surface and $d_{be} + d_{step}$ along lines that are approximately normal to the surface:

$$SAR_{uncertainty} [\%] = \Delta SAR_{be} \frac{(d_{be} + d_{step})^2}{2d_{step}} \frac{(e^{-d_{be}/(\delta/2)})}{\delta/2} \text{ for } (d_{be} + d_{step}) < 10 \text{ mm}$$

where

- $SAR_{uncertainty}$ is the uncertainty in percent of the probe boundary effect
- d_{be} is the distance between the surface and the closest *zoom-scan* measurement point, in millimetre
- Δ_{step} is the separation distance between the first and second measurement points that are closest to the phantom surface, in millimetre, assuming the boundary effect at the second location is negligible
- δ is the minimum penetration depth in millimetres of the head tissue-equivalent liquids defined in this standard, i.e., $\delta \approx 14$ mm at 3 GHz;
- ΔSAR_{be} in percent of SAR is the deviation between the measured SAR value, at the distance d_{be} from the boundary, and the analytical SAR value.

The measured worst case boundary effect SAR uncertainty[%] for scanning distances larger than 4mm is 1.0% Limit ,2%).



4 MEASUREMENT UNCERTAINTY

The guidelines outlined in the IEC/IEEE 62209-1528 and FCC KDB865664 D01 standards were followed to generate the measurement uncertainty associated with an E-field probe calibration using the waveguide technique. All uncertainties listed below represent an expanded uncertainty expressed at approximately the 95% confidence level using a coverage factor of k=2, traceable to the Internationally Accepted Guides to Measurement Uncertainty.

| Uncertainty analysis of the probe calibration in waveguide | | | | | |
|------------------------------------------------------------|-----------------------|--------------------------|---------|----|--------------------------|
| ERROR SOURCES | Uncertainty value (%) | Probability Distribution | Divisor | ci | Standard Uncertainty (%) |
| Expanded uncertainty 95 % confidence level k = 2 | | | | | 14 % |

5 CALIBRATION MEASUREMENT RESULTS

| Calibration Parameters | |
|------------------------|-------------|
| Liquid Temperature | 20 +/- 1 °C |
| Lab Temperature | 20 +/- 1 °C |
| Lab Humidity | 30-70 % |

5.1 SENSITIVITY IN AIR

| Normx dipole 1 (µV/(V/m) ²) | Normy dipole 2 (µV/(V/m) ²) | Normz dipole 3 (µV/(V/m) ²) |
|--------------------------------------------|--------------------------------------------|--------------------------------------------|
| 0.64 | 0.53 | 0.44 |

| DCP dipole 1 (mV) | DCP dipole 2 (mV) | DCP dipole 3 (mV) |
|----------------------|----------------------|----------------------|
| 106 | 108 | 109 |

Calibration curves $e_i=f(V)$ (i=1,2,3) allow to obtain E-field value using the formula:

$$E = \sqrt{E_1^2 + E_2^2 + E_3^2}$$



COMOSAR E-FIELD PROBE CALIBRATION REPORT

Ref: ACR.180.7.22.BES.B

Calibration curves

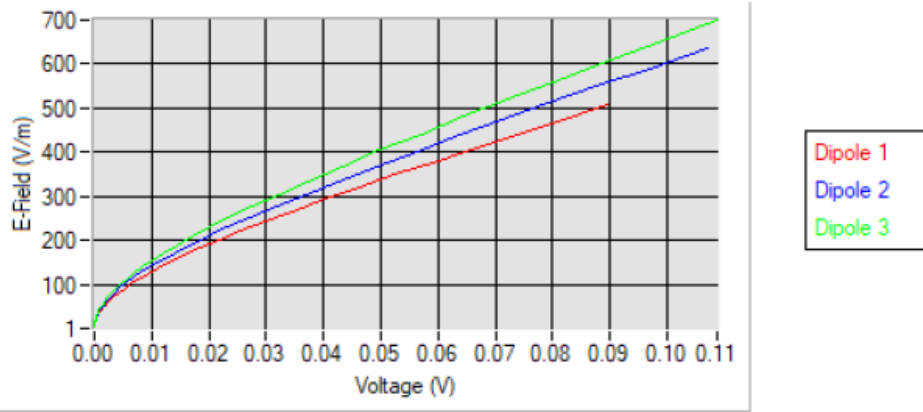

5.2 LINEARITY

Linearity

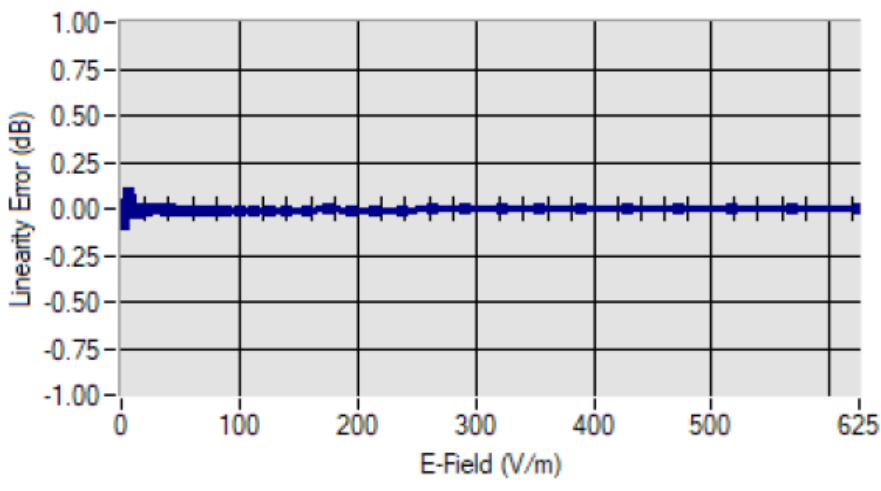

Linearity: +/-1.94% (+/-0.09dB)



COMOSAR E-FIELD PROBE CALIBRATION REPORT

Ref: ACR.180.722.BES.B

5.3 SENSITIVITY IN LIQUID

| <u>Liquid</u> | <u>Frequency (MHz +/- 100MHz)</u> | <u>ConvF</u> |
|---------------|-------------------------------------------|--------------|
| HL750 | 750 | 1.71 |
| BL750 | 750 | 1.78 |
| HL900 | 900 | 1.91 |
| BL900 | 900 | 1.96 |
| HL1800 | 1800 | 2.08 |
| BL1800 | 1800 | 2.16 |
| HL2000 | 2000 | 2.03 |
| BL2000 | 2000 | 2.10 |
| HL2450 | 2450 | 2.31 |
| BL2450 | 2450 | 2.37 |
| HL2600 | 2600 | 2.16 |
| BL2600 | 2600 | 2.23 |
| HL3500 | 3500 | 2.21 |
| BL3500 | 3500 | 2.28 |
| HL3700 | 3700 | 3.45 |
| BL3700 | 3700 | 3.15 |
| HL4600 | 4600 | 3.30 |
| BL4600 | 4600 | 3.70 |
| HL5200 | 5200 | 2.01 |
| BL5200 | 5200 | 2.08 |
| HL5600 | 5600 | 2.07 |
| BL5600 | 5600 | 2.12 |
| HL5800 | 5800 | 2.06 |
| BL5800 | 5800 | 2.13 |

LOWER DETECTION LIMIT: 7mW/kg



5.4 ISOTROPY

HL1800 MHz

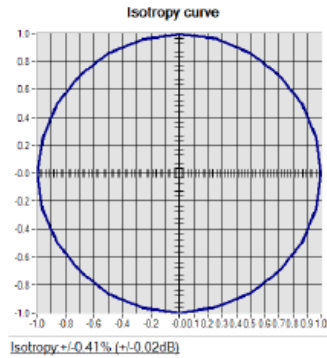



6 LIST OF EQUIPMENT

| Equipment Summary Sheet | | | | |
|------------------------------------|----------------------|-------------------------|-----------------------------------------------|-----------------------------------------------|
| Equipment Description | Manufacturer / Model | Identification No. | Current Calibration Date | Next Calibration Date |
| CALIPROBE Test Bench | Version 2 | NA | Validated. No cal required. | Validated. No cal required. |
| Network Analyzer | Rohde & Schwarz ZVM | 100203 | 08/2021 | 08/2024 |
| Network Analyzer | Agilent 8753ES | MY40003210 | 10/2023 | 10/2026 |
| Network Analyzer – Calibration kit | HP 85033D | 3423A08186 | 06/2021 | 06/2027 |
| Multimeter | Keithley 2000 | 1160271 | 02/2023 | 02/2026 |
| Signal Generator | Rohde & Schwarz SMB | 106589 | 03/2022 | 03/2025 |
| Amplifier | MVG | MODU-023-C-0002 | Characterized prior to test. No cal required. | Characterized prior to test. No cal required. |
| Power Meter | NI-USB 5680 | 170100013 | 06/2021 | 06/2024 |
| Power Meter | Rohde & Schwarz NRVD | 832839-056 | 11/2023 | 11/2026 |
| Directional Coupler | Krytar 158020 | 131467 | Characterized prior to test. No cal required. | Characterized prior to test. No cal required. |
| Waveguide | MVG | SN 32/16 WG4_1 | Validated. No cal required. | Validated. No cal required. |
| Liquid transition | MVG | SN 32/16 WGLIQ_0G900_1 | Validated. No cal required. | Validated. No cal required. |
| Waveguide | MVG | SN 32/16 WG6_1 | Validated. No cal required. | Validated. No cal required. |
| Liquid transition | MVG | SN 32/16 WGLIQ_1G500_1 | Validated. No cal required. | Validated. No cal required. |
| Waveguide | MVG | SN 32/16 WG8_1 | Validated. No cal required. | Validated. No cal required. |
| Liquid transition | MVG | SN 32/16 WGLIQ_1G800B_1 | Validated. No cal required. | Validated. No cal required. |
| Liquid transition | MVG | SN 32/16 WGLIQ_1G800H_1 | Validated. No cal required. | Validated. No cal required. |
| Waveguide | MVG | SN 32/16 WG10_1 | Validated. No cal required. | Validated. No cal required. |
| Liquid transition | MVG | SN 32/16 WGLIQ_3G500_1 | Validated. No cal required. | Validated. No cal required. |
| Waveguide | MVG | SN 32/16 WG12_1 | Validated. No cal required. | Validated. No cal required. |

Page: 10/11

Template_ACR.DDD.N.YY.MVGB.ISSUE_COMOSAR Probe vK

This document shall not be reproduced, except in full or in part, without the written approval of MVG. The information contained herein is to be used only for the purpose for which it is submitted and is not to be released in whole or part without written approval of MVG.



COMOSAR E-FIELD PROBE CALIBRATION REPORT

Ref: ACR.180.7.22.BES.B

| | | | | |
|----------------------------------|--------------|---------------------------|--------------------------------|--------------------------------|
| Liquid transition | MVG | SN 32/16 WGLIQ_5G000_1 | Validated. No cal required. | Validated. No cal required. |
| Temperature / Humidity Sensor | Testo 184 H1 | 44225320 | 06/2021 | 06/2024 |



Dielectric Probe Calibration Report

Ref: ACR.138.4.33.SATU.A

SHENZHEN TONGCE TESTING LAB
2101&2201, ZHENCHANG FACTORY, RENSHAN
INDUSTRIAL ZONE, FUHAI SUBDISTRICT, BAOAN
DISTRICT, SHENZHEN, GUANGDONG, 518103,
PEOPLES REPUBLIC OF CHINA
MVG COMOSAR DOSIMETRIC E-FIELD PROBE
FREQUENCY: 0.3-6 GHZ
SERIAL NO.: SN 19/15 OCPG 71

Calibrated at MVG US
2105 Barrett Park Dr. - Kennesaw, GA 30144



Calibration Date: 06/05/2021

Summary:

This document presents the method and results from an accredited Dielectric Probe calibration performed in MVG USA using the LIMESAR test bench. All calibration results are traceable to national metrology institutions.



SAR DIELECTRIC PROBE CALIBRATION REPORT

Ref. ACR.138.4.33..SATUA

| | Name | Function | Date | Signature |
|---------------|---------------|-----------------|------------|----------------------|
| Prepared by : | Jérôme LUC | Product Manager | 06/05/2021 | <i>JS</i> |
| Checked by : | Jérôme LUC | Product Manager | 06/05/2021 | <i>JS</i> |
| Approved by : | Kim RUTKOWSKI | Quality Manager | 06/05/2021 | <i>Kim Rutkowski</i> |

| | Customer Name |
|----------------|-----------------------------|
| Distribution : | SHENZHEN TONGCE TESTING LAB |

| Issue | Date | Modifications |
|-------|------------|-----------------|
| A | 06/05/2021 | Initial release |
| | | |
| | | |



TABLE OF CONTENTS

| | | |
|-----|-------------------------------------------|---|
| 1 | Introduction..... | 4 |
| 2 | Device Under Test | 4 |
| 3 | Product Description | 4 |
| 3.1 | General Information | 4 |
| 4 | Measurement Method | 5 |
| 4.1 | Liquid Permittivity Measurements | 5 |
| 5 | Measurement Uncertainty | 5 |
| 5.1 | Dielectric Permittivity Measurement | 5 |
| 6 | Calibration Measurement Results | 6 |
| 6.1 | Liquid Permittivity Measurement | 6 |
| 7 | List of Equipment | 7 |

Page: 3/7

*This document shall not be reproduced, except in full or in part, without the written approval of MVG.
The information contained herein is to be used only for the purpose for which it is submitted and is not to be released in whole or part without written approval of MVG.*



1 INTRODUCTION

This document contains a summary of the suggested methods and requirements set forth by the IEEE 1528 and CEI/IEC 62209 standards for liquid permittivity measurements and the measurements that were performed to verify that the product complies with the fore mentioned standards.

2 DEVICE UNDER TEST

| Device Under Test | |
|--------------------------------|--------------------------|
| Device Type | LIMESAR DIELECTRIC PROBE |
| Manufacturer | MVG |
| Model | SCLMP |
| Serial Number | SN 19/15 OCPG 71 |
| Product Condition (new / used) | Used |

A yearly calibration interval is recommended.

3 PRODUCT DESCRIPTION

3.1 GENERAL INFORMATION

MVG's Dielectric Probes are built in accordance to the IEEE 1528 and CEI/IEC 62209 standards. The product is designed for use with the LIMESAR test bench only.



Figure 1 – MVG LIMESAR Dielectric Probe



4 MEASUREMENT METHOD

The IEEE 1528, OET 65 Bulletin C and CEI/IEC 62209-1 & 2 standards outline techniques for dielectric property measurements. The LIMESAR test bench employs one of the methods outlined in the standards, using a contact probe or open-ended coaxial transmission-line probe and vector network analyzer. The standards recommend the measurement of two reference materials that have well established and stable dielectric properties to validate the system, one for the calibration and one for checking the calibration. The LIMESAR test bench uses De-ionized water as the reference for the calibration and either DMS or Methanol as the reference for checking the calibration. The following measurements were performed to verify that the product complies with the fore mentioned standards.

4.1 LIQUID PERMITTIVITY MEASUREMENTS

The permittivity of a liquid with well established dielectric properties was measured and the measurement results compared to the values provided in the fore mentioned standards.

5 MEASUREMENT UNCERTAINTY

All uncertainties listed below represent an expanded uncertainty expressed at approximately the 95% confidence level using a coverage factor of k=2, traceable to the Internationally Accepted Guides to Measurement Uncertainty.

5.1 DIELECTRIC PERMITTIVITY MEASUREMENT

The following uncertainties apply to the Dielectric Permittivity measurement:

| Uncertainty analysis of Permittivity Measurement | | | | | |
|--------------------------------------------------------------|--------------------------|--------------------------|---------|----|-----------------------------|
| ERROR SOURCES | Uncertainty value (+/-%) | Probability Distribution | Divisor | ci | Standard Uncertainty (+/-%) |
| Repeatability (n repeats, mid-band) | 4.00% | N | 1 | 1 | 4.000% |
| Deviation from reference liquid | 5.00% | R | √3 | 1 | 2.887% |
| Network analyser-drift, linearity | 2.00% | R | √3 | 1 | 1.155% |
| Test-port cable variations | 0.00% | U | √2 | 1 | 0.000% |
| Combined standard uncertainty | | | | | 5.066% |
| Expanded uncertainty (confidence level of 95%, k = 2) | | | | | 10.0% |

| Uncertainty analysis of Conductivity Measurement | | | | | |
|--------------------------------------------------------------|--------------------------|--------------------------|---------|----|-----------------------------|
| ERROR SOURCES | Uncertainty value (+/-%) | Probability Distribution | Divisor | ci | Standard Uncertainty (+/-%) |
| Repeatability (n repeats, mid-band) | 3.50% | N | 1 | 1 | 3.500% |
| Deviation from reference liquid | 3.00% | R | √3 | 1 | 1.732% |
| Network analyser-drift, linearity | 2.00% | R | √3 | 1 | 1.155% |
| Test-port cable variations | 0.00% | U | √2 | 1 | 0.000% |
| Combined standard uncertainty | | | | | 4.072% |
| Expanded uncertainty (confidence level of 95%, k = 2) | | | | | 8.1% |



SAR DIELECTRIC PROBE CALIBRATION REPORT

Ref. ACR.138.4.33..SATU.A

6 CALIBRATION MEASUREMENT RESULTS

Measurement Condition

| | |
|--------------------|---------|
| Software | LIMESAR |
| Liquid Temperature | 21°C |
| Lab Temperature | 21°C |
| Lab Humidity | 44% |

6.1 LIQUID PERMITTIVITY MEASUREMENT

A liquid of known characteristics (methanol at 20°C) is measured with the probe and the results (complex permittivity $\epsilon' + j\epsilon''$) are compared with the well-known theoretical values for this liquid.

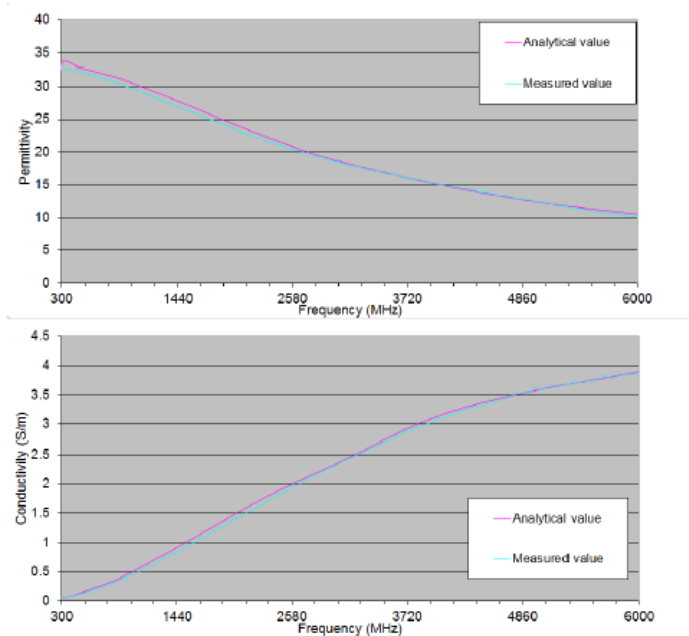



7 LIST OF EQUIPMENT

| Equipment Summary Sheet | | | | |
|---------------------------------|----------------------|--------------------|-----------------------------|-----------------------------|
| Equipment Description | Manufacturer / Model | Identification No. | Current Calibration Date | Next Calibration Date |
| LIMESAR Test Bench | Version 3 | NA | Validated. No cal required. | Validated. No cal required. |
| Network Analyzer | Rhode & Schwarz ZVA | SN100132 | 02/2021 | 02/2024 |
| Methanol CAS 67-56-1 | Alpha Aesar | Lot D13W011 | Validated. No cal required. | Validated. No cal required. |
| Temperature and Humidity Sensor | Control Company | 11-661-9 | 09/2022 | 09/2023 |

Appendix D: Dipole Calibration Report

SID750



SAR Reference Dipole Calibration Report

Ref : ACR.156.3.15.SATU.A

SHENZHEN TONGCE TESTING LAB
2101&2201, ZHENCHANG FACTORY, RENSHAN
INDUSTRIAL ZONE, FUHAI SUBDISTRICT, BAOAN
DISTRICT, SHENZHEN, GUANGDONG, 518103,
PEOPLES REPUBLIC OF CHINA

COMOSAR REFERENCE DIPOLE
FREQUENCY: 750 MHZ
SERIAL NO.: SN 16/15 DIP 0G750-368

Calibrated at MVG US
2105 Barrett Park Dr. - Kennesaw, GA 30144



Calibration Date: 06/05/2021

Summary:

This document presents the method and results from an accredited SAR reference dipole calibration performed in MVG USA using the COMOSAR test bench. All calibration results are traceable to national metrology institutions.



SAR REFERENCE DIPOLE CALIBRATION REPORT

Ref: ACR.156.3.15.SATU.A

| | <i>Name</i> | <i>Function</i> | <i>Date</i> | <i>Signature</i> |
|----------------------|---------------|-----------------|-------------|----------------------|
| <i>Prepared by :</i> | Jérôme LUC | Product Manager | 06/05/2021 | <i>JL</i> |
| <i>Checked by :</i> | Jérôme LUC | Product Manager | 06/05/2021 | <i>JL</i> |
| <i>Approved by :</i> | Kim RUTKOWSKI | Quality Manager | 06/05/2021 | <i>Kim Rutkowski</i> |

| | <i>Customer Name</i> |
|-----------------------|-----------------------------|
| <i>Distribution :</i> | SHENZHEN TONGCE TESTING LAB |

| <i>Issue</i> | <i>Date</i> | <i>Modifications</i> |
|--------------|-------------|----------------------|
| A | 06/05/2021 | Initial release |
| | | |
| | | |



TABLE OF CONTENTS

| | | |
|-----|-----------------------------------------------|----|
| 1 | Introduction..... | 4 |
| 2 | Device Under Test..... | 4 |
| 3 | Product Description..... | 4 |
| 3.1 | General Information..... | 4 |
| 4 | Measurement Method..... | 5 |
| 4.1 | Return Loss Requirements..... | 5 |
| 4.2 | Mechanical Requirements..... | 5 |
| 5 | Measurement Uncertainty..... | 5 |
| 5.1 | Return Loss..... | 5 |
| 5.2 | Dimension Measurement..... | 5 |
| 5.3 | Validation Measurement..... | 5 |
| 6 | Calibration Measurement Results..... | 6 |
| 6.1 | Return Loss and Impedance In Head Liquid..... | 6 |
| 6.2 | Return Loss and Impedance In Body Liquid..... | 6 |
| 6.3 | Mechanical Dimensions..... | 6 |
| 7 | Validation measurement..... | 7 |
| 7.1 | Head Liquid Measurement..... | 7 |
| 7.2 | SAR Measurement Result With Head Liquid..... | 8 |
| 7.3 | Body Liquid Measurement..... | 9 |
| 7.4 | SAR Measurement Result With Body Liquid..... | 10 |
| 8 | List of Equipment..... | 11 |



1 INTRODUCTION

This document contains a summary of the requirements set forth by the IEEE 1528, FCC KDBs and CEI/IEC 62209 standards for reference dipoles used for SAR measurement system validations and the measurements that were performed to verify that the product complies with the fore mentioned standards.

2 DEVICE UNDER TEST

| Device Under Test | |
|--------------------------------|----------------------------------|
| Device Type | COMOSAR 750 MHz REFERENCE DIPOLE |
| Manufacturer | MVG |
| Model | SID750 |
| Serial Number | SN 16/15 DIP 0G750-368 |
| Product Condition (new / used) | Used |

A yearly calibration interval is recommended.

3 PRODUCT DESCRIPTION

3.1 GENERAL INFORMATION

MVG's COMOSAR Validation Dipoles are built in accordance to the IEEE 1528, FCC KDBs and CEI/IEC 62209 standards. The product is designed for use with the COMOSAR test bench only.



Figure 1 – MVG COMOSAR Validation Dipole