

TEST REPORT



Report No.: TW2305186-04E
Applicant: JAEWONCNC Co.,Ltd
Product: Wireless USB Adapter
Model No.: WD-4512BT
Trademark: IROAD
Test Standards: FCC Part 15 Subpart E, Paragraph 15.407

Test Result: It is herewith confirmed and found to comply with the requirements set up by ANSI C63.10, FCC Part 15 Subpart C, Paragraph 15.247 for the evaluation of electromagnetic compatibility

Approved By

A handwritten signature in black ink that reads 'Terry Tang'.

Terry Tang

Manager

Dated: May 30, 2023

Results appearing herein relate only to the sample tested
The technical reports is issued errors and omissions exempt and is subject to withdrawal at

SHENZHEN TIMEWAY TESTING LABORATORIES

Zone C, 1st Floor, Block B, Jun Xiang Da Building, Zhongshan Park Road West, Tong Le Village, Nanshan District, Shenzhen, China
Tel (755) 83448688, Fax (755) 83442996, E-Mail:info@timeway-lab.com



Special Statement:

The testing quality ability of our laboratory meet with “Quality Law of People’s Republic of China” Clause 19.

The testing quality system of our laboratory meet with ISO/IEC-17025 requirements, which is approved by CNAL. This approval result is accepted by MRA of APLAC.

Our test facility is recognized, certified, or accredited by the following organizations:

CNAS-LAB Code: L2292

The EMC Laboratory has been assessed and in compliance with CNAS-CL01 accreditation criteria for testing Laboratories (identical to ISO/IEC 17025:2017 General Requirements) for the Competence of testing Laboratories.

FCC-Registration No.: 744189

The EMC Laboratory has been registered and fully described in a report filed with the (FCC) Federal Communications commission. The acceptance letter from the FCC is maintained in our files. Registration No.: 744189.

Industry Canada (IC) —Registration No.:5205A

The EMC Laboratory has been registered by Certification and Engineering Bureau of Industry Canada for radio equipment testing with Registration No.: 5205A.

A2LA (Certification Number:5013.01)

The EMC Laboratory has been accredited by the American Association for Laboratory Accreditation (A2LA). Certification Number:5013.01

CAB identifier: CN0033



Test Report Conclusion
Content

1.0	General Details	4
1.1	Test Lab Details.....	4
1.2	Applicant Details.....	4
1.3	Description of EUT	4
1.4	Submitted Sample.....	5
1.5	Test Duration.....	5
1.6	Test Uncertainty.....	5
1.7	Test By.....	5
2.0	List of Measurement Equipment	6
3.0	Technical Details	7
3.1	Summary of Test Results.....	7
3.2	Test Standards.....	7
4.0	EUT Modification	7
5.0	Power Line Conducted Emission Test	8
5.1	Schematics of the Test.....	8
5.2	Test Method and Test Procedure.....	8
5.3	Configuration of the EUT.....	8
5.4	EUT Operating Condition.....	9
5.5	Conducted Emission Limit.....	9
5.6	Test Result.....	9
6.0	Undesirable Emission and Restrict band	12
7.0	Bandwidth Measurement	26
8.0	Peak Transmit Power Measurement	43
9.0	Peak Power Spectral Density Measurement	52
10.0	Frequency Stability	61
11.0	Antenna Requirement	63
12.0	FCC ID Label	64
13.0	Photo of Test Setup and EUT View	65

The report refers only to the sample tested and does not apply to the bulk.
This report is issued in confidence to the client and it will be strictly treated as such by the SHENZHEN TIMEWAY TESTING LABORATORIES. It may not be reproduced rather in its entirety or in part and it may not be used for adverting. The client to whom the report is issued may, however, show or send it . or a certified copy there of prepared by the SHENZHEN TIMEWAY TESTING LABORATORIES. to his customer. Supplier or others persons directly concerned. SHENZHEN TIMEWAY TESTING LABORATORIES. will not, without the consent of the client enter into any discussion of correspondence with any third party concerning the contents of the report.
In the event of the improper use of the report. The SHENZHEN TIMEWAY TESTING LABORATORIES. reserves the rights to withdraw it and to adopt any other remedies which may be appropriate.



1.0 General Details

1.1 Test Lab Details

Name: SHENZHEN TIMEWAY TESTING LABORATORIES.
Address: Zone C, 1st Floor, Block B, Jun Xiang Da Building, Zhongshan Park Road West, Tong Le Village, Nanshan District, Shenzhen, China
Telephone: (755) 83448688
Fax: (755) 83442996
Site Listed with Federal Communications commission (FCC)
Registration Number: 744189
For 3m Anechoic Chamber
Site Listed with Industry Canada of Ottawa, Canada
Registration Number: IC: 5205A-02
For 3m Anechoic Chamber

1.2 Applicant Details

Applicant: JAEWONCNC Co.,Ltd
Address: A-501~510, 517, H-Businesspark, 25, Beobwon-ro 11-gil, Songpa-gu, Seoul, Republic of Korea
Telephone: --
Fax: --

1.3 Description of EUT

Product: Wireless USB Adapter
Manufacturer: JAEWONCNC Co.,Ltd
Address: A-501~510, 517, H-Businesspark, 25, Beobwon-ro 11-gil, Songpa-gu, Seoul, Republic of Korea
Trademark: IROAD
Additional Trademark: N/A
Model Number: WD-4512BT
Additional Model Number: N/A
Type of Modulation: IEEE 802.11a/n (HT20/HT40): OFDM (64QAM, 16QAM, QPSK, BPSK);
IEEE 802.11ac: BPSK, QPSK, 16-QAM, 64-QAM, 256-QAM
Frequency: Band 4: 5745MHz-5825MHz
Air Data Rate: IEEE 802.11a: 54, 48,36, 24, 18, 12, 9, 6 Mbps
IEEE 802.11n/HT20: mcs0-mcs15
IEEE 802.11n/HT40: mcs0-mcs15
IEEE 802.11ac: NSS1 mcs0-mcs9
Antenna: Integral with gain -0.8dBi for Band 4 (Get from the antenna specification)
Test Mode: During testing, EUT was set to 100% duty cycle. 6Mbps air data rate was the worst case for 802.11a mode; mcs0 air data rate was the worst case for 802.11n mode;

The report refers only to the sample tested and does not apply to the bulk.

This report is issued in confidence to the client and it will be strictly treated as such by the SHENZHEN TIMEWAY TESTING LABORATORIES. It may not be reproduced rather in its entirety or in part and it may not be used for advertising. The client to whom the report is issued may, however, show or send it or a certified copy thereof prepared by the SHENZHEN TIMEWAY TESTING LABORATORIES to his customer. Supplier or others persons directly concerned. SHENZHEN TIMEWAY TESTING LABORATORIES will not, without the consent of the client enter into any discussion of correspondence with any third party concerning the contents of the report.

In the event of the improper use of the report. The SHENZHEN TIMEWAY TESTING LABORATORIES reserves the rights to withdraw it and to adopt any other remedies which may be appropriate.



Frequency Selection By software
 Rating: DC5V, 500mA, 2.5W

Each Channel Operation Frequency

Band 4					
802.11a / 11n HT20 / 802.11ac VHT20		802.11n HT40 / 802.11acVHT40		802.11ac VHT80	
Channel	Frequency	Channel	Frequency	Channel	Frequency
149	5745 MHz	151	5755 MHz	155	5775 MHz
153	5765 MHz	159	5795 MHz		
157	5785 MHz				
161	5825 MHz				

The selected test channels as follows:

Band 4					
802.11a / 11n HT20		802.11n HT40		802.11ac VHT80	
Channel	Frequency	Channel	Frequency	Channel	Frequency
149	5745 MHz	151	5755 MHz	155	5775 MHz
153	5765 MHz	159	5795 MHz		
161	5825 MHz				

Note: 802.11ac VHT20/VHT40 is similar with 802.11n HT20/HT40.

1.4 Submitted Sample: 1 Sample

1.5 Test Duration
 2023-05-16 to 2023-05-30

1.6 Test Uncertainty
 Conducted Emissions Uncertainty =3.6dB
 Radiated Emissions Uncertainty =4.7dB

1.7 Test Engineer *Andy Xing*
 The sample tested by _____

Print Name: Andy Xing

The report refers only to the sample tested and does not apply to the bulk.
 This report is issued in confidence to the client and it will be strictly treated as such by the SHENZHEN TIMEWAY TESTING LABORATORIES. It may not be reproduced rather in its entirety or in part and it may not be used for advertising. The client to whom the report is issued may, however, show or send it . or a certified copy there of prepared by the SHENZHEN TIMEWAY TESTING LABORATORIES. to his customer. Supplier or others persons directly concerned. SHENZHEN TIMEWAY TESTING LABORATORIES. will not, without the consent of the client enter into any discussion of correspondence with any third party concerning the contents of the report.
 In the event of the improper use of the report. The SHENZHEN TIMEWAY TESTING LABORATORIES. reserves the rights to withdraw it and to adopt any other remedies which may be appropriate.



2.0 Test Equipment					
Instrument Type	Manufacturer	Model	Serial No.	Date of Cal.	Due Date
ESPI Test Receiver	R&S	ESPI 3	100379	2022-07-15	2023-07-14
LISN	R&S	EZH3-Z5	100294	2022-07-18	2023-07-17
LISN	R&S	EZH3-Z5	100253	2022-07-18	2023-07-17
Impuls-Begrenzer	R&S	ESH3-Z2	100281	2022-07-18	2023-07-17
Loop Antenna	EMCO	6507	00078608	2022-07-18	2025-07-17
Spectrum	R&S	FSIQ26	100292	2022-07-15	2023-07-14
Horn Antenna	A-INFO	LB-180400-KF	J211060660	2022-07-18	2025-07-17
Horn Antenna	R&S	BBHA 9120D	9120D-631	2022-07-18	2024-07-17
Power meter	Anritsu	ML2487A	6K00003613	2022-07-18	2023-07-17
Power sensor	Anritsu	MA2491A	32263	2022-07-18	2023-07-17
Bilog Antenna	Schwarebeck	VULB9163	9163/340	2022-07-18	2025-07-17
9*6*6 Anechoic	--	--	N/A	2022-07-26	2025-07-25
EMI Test Receiver	RS	ESVB	826156/011	2022-07-15	2023-07-14
EMI Test Receiver	RS	ESCS 30	834115/006	2022-07-15	2023-07-14
Spectrum	HP/Agilent	E4407B	MY50441392	2022-07-15	2023-07-14
Spectrum	RS	FSP	1164.4391.38	2022-07-15	2023-07-14
RF Cable	Zhengdi	ZT26-NJ-NJ-8 M/FA	--	2022-07-15	2023-07-14
RF Cable	Zhengdi	7m	--	2022-07-15	2023-07-14
Pre-Amplifier	Schwarebeck	BBV9743	#218	2022-07-15	2023-07-14
Pre-Amplifier	HP/Agilent	8449B	3008A00160	2022-07-15	2023-07-14
LISN	SCHAFFNER	NNB42	00012	2022-08-18	2023-07-17
ESPI Test Receiver	R&S	ESPI 3	100379	2022-07-15	2023-07-14
LISN	R&S	EZH3-Z5	100294	2022-07-18	2023-07-17

2.2 Automation Test Software

For Conducted Emission Test

Name	Version
EZ-EMC	Ver.EMC-CON 3A1.1

For Radiated Emissions

Name	Version
EMI Test Software BL410-EV18.91	V18.905
EMI Test Software BL410-EV18.806 High Frequency	V18.06

The report refers only to the sample tested and does not apply to the bulk.

This report is issued in confidence to the client and it will be strictly treated as such by the SHENZHEN TIMEWAY TESTING LABORATORIES. It may not be reproduced rather in its entirety or in part and it may not be used for advertising. The client to whom the report is issued may, however, show or send it, or a certified copy thereof prepared by the SHENZHEN TIMEWAY TESTING LABORATORIES, to his customer. Supplier or others persons directly concerned. SHENZHEN TIMEWAY TESTING LABORATORIES, will not, without the consent of the client enter into any discussion of correspondence with any third party concerning the contents of the report.

In the event of the improper use of the report. The SHENZHEN TIMEWAY TESTING LABORATORIES, reserves the rights to withdraw it and to adopt any other remedies which may be appropriate.



3.0 Technical Details

3.1 Summary of test results

The EUT has been tested according to the following specifications:			
Standard	Test Type	Result	Notes
FCC Part 15, Paragraph 15.107 & 15.407	Conducted Emission Test	Pass	Complies
FCC Part 15 Subpart E Paragraph 15.407 (b1/4/5/6/7), Part 15.205 and Part 15.209	Undesirable Emission and Restrict band	Pass	Complies
FCC Part 15, Paragraph 15.407 (a1/2/3)	Peak Transmit Power	Pass	Complies
FCC Part 15, Paragraph 15.407 (a)(6)	Peak Power Excursion	Pass	Complies
FCC Part 15, Paragraph 15.407 (a1/2/3)	Peak Power Spectral Density	Pass	Complies
FCC Part 15, Paragraph 15.407(g)	Frequency Stability	Pass	Complies

3.2 Test Standards

FCC Part 15 Subpart & Subpart C, Paragraph 15.247, ANSI C63.10 :2013, ANSI C63.4 :2014 789033 D02 General UNII Test Procedures New Rules v01r04

4.0 EUT Modification

No modification by SHENZHEN TIMEWAY TESTING LABORATORIES.

The report refers only to the sample tested and does not apply to the bulk.
 This report is issued in confidence to the client and it will be strictly treated as such by the SHENZHEN TIMEWAY TESTING LABORATORIES. It may not be reproduced rather in its entirety or in part and it may not be used for adverting. The client to whom the report is issued may, however, show or send it . or a certified copy there of prepared by the SHENZHEN TIMEWAY TESTING LABORATORIES. to his customer. Supplier or others persons directly concerned. SHENZHEN TIMEWAY TESTING LABORATORIES. will not, without the consent of the client enter into any discussion of correspondence with any third party concerning the contents of the report.
 In the event of the improper use of the report. The SHENZHEN TIMEWAY TESTING LABORATORIES. reserves the rights to withdraw it and to adopt any other remedies which may be appropriate.



5. Power Line Conducted Emission Test

5.1 Schematics of the test

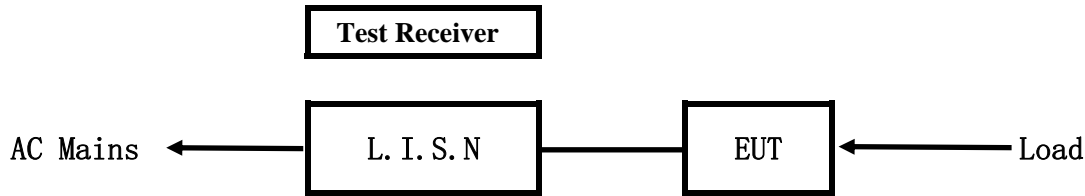

EUT: Equipment Under Test

5.2 Test Method and test Procedure

The EUT was tested according to ANSI C63.10-2013. The Frequency spectrum from 0.15MHz to 30MHz was investigated. The LISN used was 50ohm/50uH as specified by section 5.1 of ANSI C63.10-2013.

Test Voltage: 120V~, 60Hz

Block diagram of Test setup

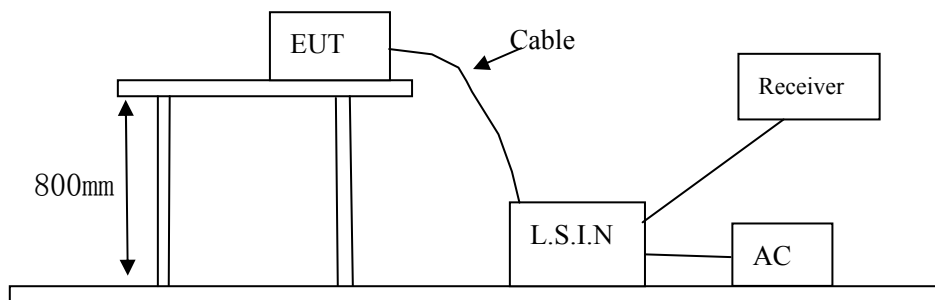

5.3 Configuration of The EUT

The EUT was configured according to ANSI C63.10-2013. All interface ports were connected to the appropriate peripherals. All peripherals and cables are listed below.

A. EUT

Device	Manufacturer	Model	FCC ID
Wireless USB Adapter	JAEWONCNC Co.,Ltd	WD-4512BT	2BA5E-WD4512BT

The report refers only to the sample tested and does not apply to the bulk.

This report is issued in confidence to the client and it will be strictly treated as such by the SHENZHEN TIMEWAY TESTING LABORATORIES. It may not be reproduced rather in its entirety or in part and it may not be used for advertizing. The client to whom the report is issued may, however, show or send it . or a certified copy there of prepared by the SHENZHEN TIMEWAY TESTING LABORATORIES. to his customer. Supplier or others persons directly concerned. SHENZHEN TIMEWAY TESTING LABORATORIES. will not, without the consent of the client enter into any discussion of correspondence with any third party concerning the contents of the report.

In the event of the improper use of the report. The SHENZHEN TIMEWAY TESTING LABORATORIES. reserves the rights to withdraw it and to adopt any other remedies which may be appropriate.



B. Internal Device

Device	Manufacturer	Model	Rating

C. Peripherals

Device	Manufacturer	Model	Rating
PC	Dell	P54G	DC19V, 3.3A

5.4 EUT Operating Condition

Operating condition is according to ANSI C63.10 -2013.

A Setup the EUT and simulators as shown on follow

B Enable AF signal and confirm EUT active to normal condition

5.5 Power line conducted Emission Limit according to Paragraph 15.207

Frequency (MHz)	Limits (dB μ V)	
	Quasi-peak Level	Average Level
0.15 ~ 0.50	66.0~56.0*	56.0~46.0*
0.50 ~ 5.00	56.0	46.0
5.00 ~ 30.00	60.0	50.0

- Notes: 1. *Decreasing linearly with logarithm of frequency.
 2. The tighter limit shall apply at the transition frequencies

5.6 Test Results

The frequency spectrum from 0.15MHz to 30MHz was investigated. All reading are quasi-peak values with a resolution bandwidth of 9kHz.

The report refers only to the sample tested and does not apply to the bulk.
 This report is issued in confidence to the client and it will be strictly treated as such by the SHENZHEN TIMEWAY TESTING LABORATORIES. It may not be reproduced rather in its entirety or in part and it may not be used for adverting. The client to whom the report is issued may, however, show or send it . or a certified copy there of prepared by the SHENZHEN TIMEWAY TESTING LABORATORIES. to his customer. Supplier or others persons directly concerned. SHENZHEN TIMEWAY TESTING LABORATORIES. will not, without the consent of the client enter into any discussion of correspondence with any third party concerning the contents of the report.
 In the event of the improper use of the report. The SHENZHEN TIMEWAY TESTING LABORATORIES. reserves the rights to withdraw it and to adopt any other remedies which may be appropriate.



A: Conducted Emission on Live Terminal (150kHz to 30MHz)

EUT Operating Environment

Temperature: 26°C Humidity: 65%RH Atmospheric Pressure: 101 kPa

EUT set Condition: Keeping WIFI Transmitting

Results: Pass

Please refer to following diagram for individual

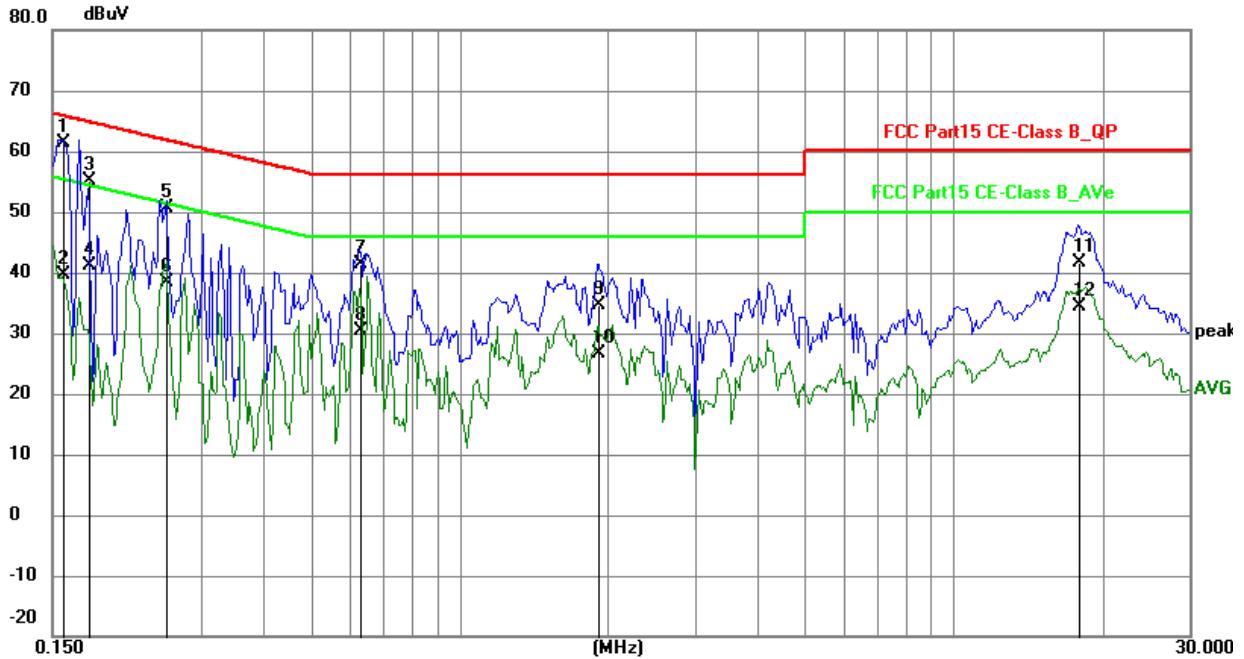

No.	Frequency (MHz)	Reading (dBuV)	Factor (dB)	Level (dBuV)	Limit (dBuV)	Margin (dB)	Detector	P/F
1	0.1578	51.65	9.78	61.43	65.58	-4.15	QP	P
2	0.1578	29.95	9.78	39.73	55.58	-15.85	AVG	P
3	0.1773	45.47	9.77	55.24	64.61	-9.37	QP	P
4	0.1773	31.36	9.77	41.13	54.61	-13.48	AVG	P
5	0.2553	40.92	9.75	50.67	61.58	-10.91	QP	P
6	0.2553	28.75	9.75	38.50	51.58	-13.08	AVG	P
7	0.6297	31.58	9.78	41.36	56.00	-14.64	QP	P
8	0.6297	20.52	9.78	30.30	46.00	-15.70	AVG	P
9	1.9050	24.77	9.80	34.57	56.00	-21.43	QP	P
10	1.9050	16.76	9.80	26.56	46.00	-19.44	AVG	P
11	17.8980	31.18	10.55	41.73	60.00	-18.27	QP	P
12	17.8980	23.85	10.55	34.40	50.00	-15.60	AVG	P

The report refers only to the sample tested and does not apply to the bulk.

This report is issued in confidence to the client and it will be strictly treated as such by the SHENZHEN TIMEWAY TESTING LABORATORIES. It may not be reproduced rather in its entirety or in part and it may not be used for advertising. The client to whom the report is issued may, however, show or send it, or a certified copy thereof prepared by the SHENZHEN TIMEWAY TESTING LABORATORIES, to his customer. Supplier or others persons directly concerned. SHENZHEN TIMEWAY TESTING LABORATORIES, will not, without the consent of the client enter into any discussion of correspondence with any third party concerning the contents of the report.

In the event of the improper use of the report. The SHENZHEN TIMEWAY TESTING LABORATORIES, reserves the rights to withdraw it and to adopt any other remedies which may be appropriate.



B: Conducted Emission on Neutral Terminal (150kHz to 30MHz)

EUT Operating Environment

Temperature: 26°C Humidity: 65%RH Atmospheric Pressure: 101 kPa

EUT set Condition: Keeping WIFI Transmitting

Results: Pass

Please refer to following diagram for individual

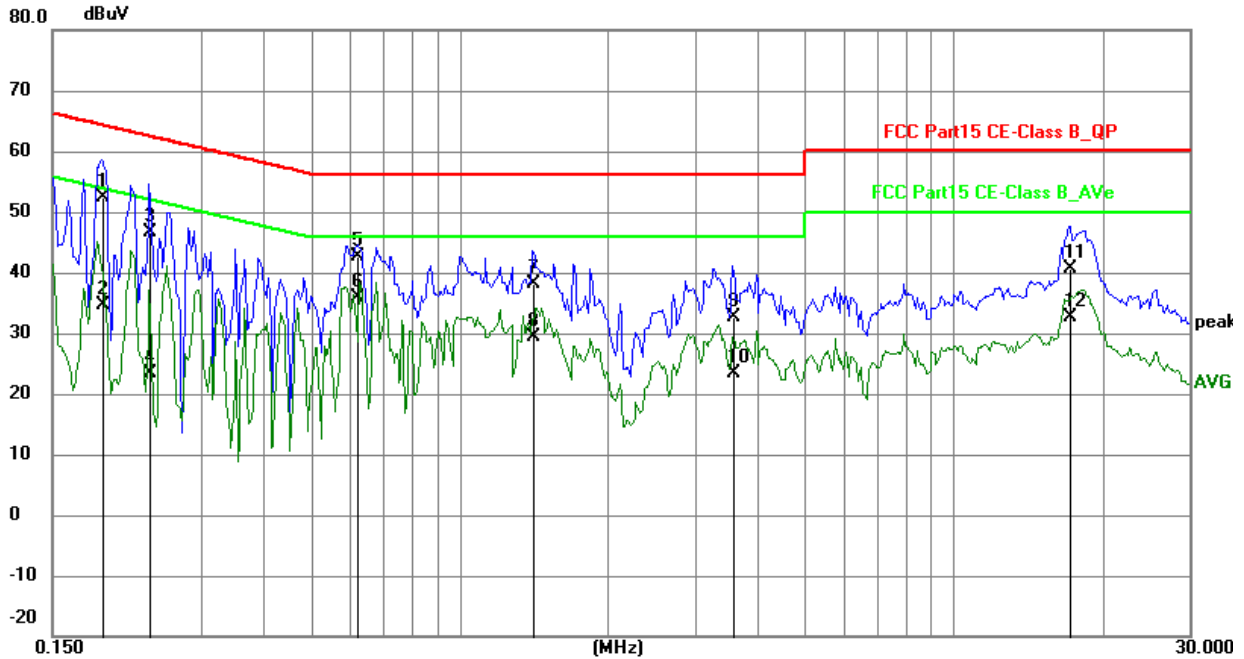

No.	Frequency (MHz)	Reading (dBuV)	Factor (dB)	Level (dBuV)	Limit (dBuV)	Margin (dB)	Detector	P/F
1	0.1890	42.56	9.76	52.32	64.08	-11.76	QP	P
2	0.1890	24.78	9.76	34.54	54.08	-19.54	AVG	P
3	0.2358	37.00	9.75	46.75	62.24	-15.49	QP	P
4	0.2358	13.75	9.75	23.50	52.24	-28.74	AVG	P
5	0.6219	32.93	9.78	42.71	56.00	-13.29	QP	P
6	0.6219	26.10	9.78	35.88	46.00	-10.12	AVG	P
7	1.4097	28.33	9.79	38.12	56.00	-17.88	QP	P
8	1.4097	19.61	9.79	29.40	46.00	-16.60	AVG	P
9	3.5694	22.87	9.87	32.74	56.00	-23.26	QP	P
10	3.5694	13.50	9.87	23.37	46.00	-22.63	AVG	P
11	17.1843	30.09	10.51	40.60	60.00	-19.40	QP	P
12	17.1843	22.09	10.51	32.60	50.00	-17.40	AVG	P

The report refers only to the sample tested and does not apply to the bulk.

This report is issued in confidence to the client and it will be strictly treated as such by the SHENZHEN TIMEWAY TESTING LABORATORIES. It may not be reproduced rather in its entirety or in part and it may not be used for advertising. The client to whom the report is issued may, however, show or send it or a certified copy thereof prepared by the SHENZHEN TIMEWAY TESTING LABORATORIES to his customer. Supplier or others persons directly concerned. SHENZHEN TIMEWAY TESTING LABORATORIES will not, without the consent of the client enter into any discussion of correspondence with any third party concerning the contents of the report.

In the event of the improper use of the report. The SHENZHEN TIMEWAY TESTING LABORATORIES reserves the rights to withdraw it and to adopt any other remedies which may be appropriate.

6 Undesirable Emission and Restrict band

6.1 Test Method and test Procedure:

- (1) The EUT was tested according to ANSI C63.10-2013. The radiated test was performed at Timeway EMC Laboratory. This site is on file with the FCC laboratory division, Registration No. 744189
- (2) The EUT, peripherals were put on the turntable which table size is 1m x 1.5 m, table high 0.8 m. All set up is according to ANSI C63.10-2013.
- (3) The frequency spectrum from 30 MHz to 40 GHz was investigated. All readings from 30 MHz to 1 GHz are Quasi-peak values with a resolution bandwidth of 120 kHz. For measurement above 1GHz, peak values with RBW=1MHz, VBW=3MHz and PK detector. Measurements were made at 3 meters.
- (4) The antenna high is varied from 1 m to 4 m high to find the maximum emission for each frequency.
- (5) Maximizing procedure was performed on the six (6) highest emissions to ensure EUT compliance is with all installation combinations. All data was recorded in the peak detection mode. Quasi-peak readings was performed only when an emission was found to be marginal (within -4 dB of specification limit), and are distinguished with a “QP” in the data table.
- (6) The antenna polarization: Vertical polarization and Horizontal polarization.

Block diagram of Test setup

For radiated emissions from 9kHz to 30MHz

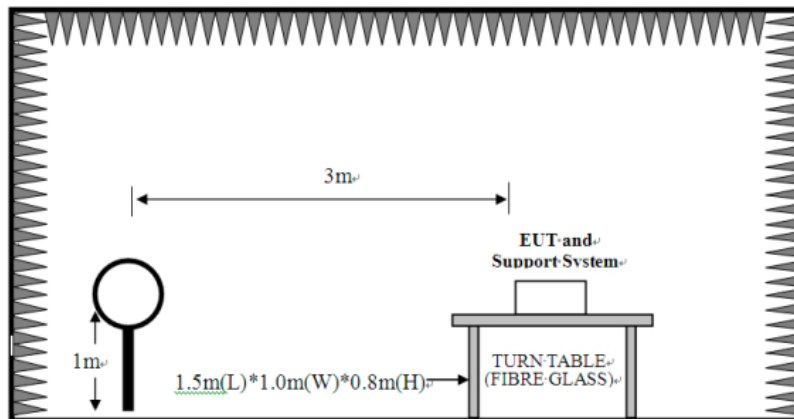

The report refers only to the sample tested and does not apply to the bulk.

This report is issued in confidence to the client and it will be strictly treated as such by the SHENZHEN TIMEWAY TESTING LABORATORIES. It may not be reproduced rather in its entirety or in part and it may not be used for advertising. The client to whom the report is issued may, however, show or send it, or a certified copy thereof prepared by the SHENZHEN TIMEWAY TESTING LABORATORIES, to his customer. Supplier or others persons directly concerned. SHENZHEN TIMEWAY TESTING LABORATORIES, will not, without the consent of the client enter into any discussion of correspondence with any third party concerning the contents of the report.

In the event of the improper use of the report. The SHENZHEN TIMEWAY TESTING LABORATORIES, reserves the rights to withdraw it and to adopt any other remedies which may be appropriate.



For radiated emissions from 30MHz to1GHz

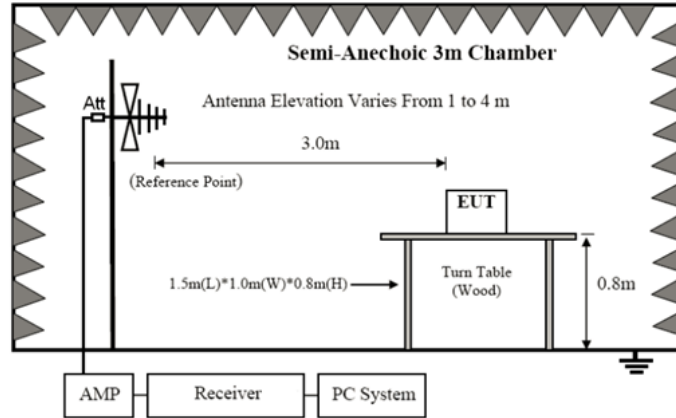

For radiated emissions above 1GHz

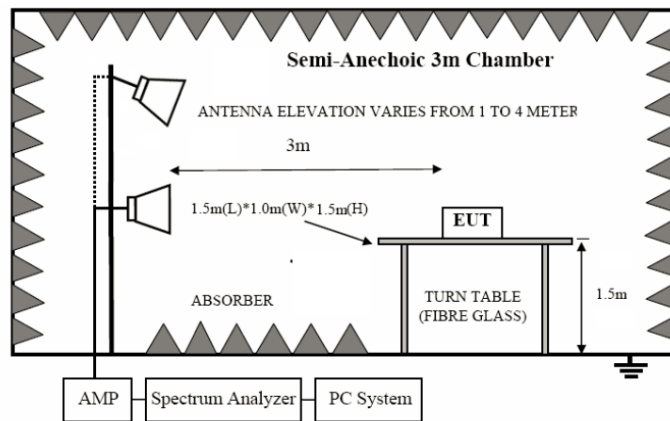

6.2 Configuration of the EUT

Same as section 5.3 of this report

6.3 EUT Operating Condition

Same as section 5.4 of this report.

6.4 Radiated Emission Limit

All emission from a digital device, including any network of conductors and apparatus connected thereto, shall not exceed the level of field strength specified below:

The report refers only to the sample tested and does not apply to the bulk.

This report is issued in confidence to the client and it will be strictly treated as such by the SHENZHEN TIMEWAY TESTING LABORATORIES. It may not be reproduced rather in its entirety or in part and it may not be used for advertising. The client to whom the report is issued may, however, show or send it, or a certified copy thereof, to the SHENZHEN TIMEWAY TESTING LABORATORIES, to his customer, Supplier or others persons directly concerned. SHENZHEN TIMEWAY TESTING LABORATORIES, will not, without the consent of the client enter into any discussion of correspondence with any third party concerning the contents of the report.

In the event of the improper use of the report, The SHENZHEN TIMEWAY TESTING LABORATORIES, reserves the rights to withdraw it and to adopt any other remedies which may be appropriate.



Frequencies in restricted band are complied to limit on Paragraph 15.209

Frequency Range (MHz)	Distance (m)	Field strength (dB μ V/m)
30-88	3	40.0
88-216	3	43.5
216-960	3	46.0
Above 960	3	54.0

- (1) For transmitters operating in the 5.15-5.25 GHz band: all emissions outside of the 5.15-5.35 GHz band shall not exceed an EIRP of -27dBm/MHz
- (2) For transmitters operating in the 5.725-5.825 GHz band: all emissions within the frequency range from the band edge to 10 MHz above or below the band edge shall not exceed an EIRP of -17dBm/MHz; for frequencies 10 MHz or greater above or below the band edge, emissions shall not exceed an EIRP of -27dBm/MHz.

- Note:
1. RF Voltage (dBuV) = 20 log RF Voltage (uV)
 2. In the Above Table, the higher limit applies at the band edges.
 3. Distance refers to the distance in meters between the measuring instrument antenna and the EUT

The report refers only to the sample tested and does not apply to the bulk.
This report is issued in confidence to the client and it will be strictly treated as such by the SHENZHEN TIMEWAY TESTING LABORATORIES. It may not be reproduced rather in its entirety or in part and it may not be used for advertising. The client to whom the report is issued may, however, show or send it or a certified copy thereof prepared by the SHENZHEN TIMEWAY TESTING LABORATORIES to his customer. Supplier or others persons directly concerned. SHENZHEN TIMEWAY TESTING LABORATORIES will not, without the consent of the client enter into any discussion of correspondence with any third party concerning the contents of the report.
In the event of the improper use of the report. The SHENZHEN TIMEWAY TESTING LABORATORIES reserves the rights to withdraw it and to adopt any other remedies which may be appropriate.



Test result

General Radiated Emission Data and Harmonics Radiated Emission Data

Radiated Emission In Horizontal (30MHz----1000MHz)

EUT set Condition: Keeping WIFI Transmitting

Results: Pass

The report refers only to the sample tested and does not apply to the bulk.

This report is issued in confidence to the client and it will be strictly treated as such by the SHENZHEN TIMEWAY TESTING LABORATORIES. It may not be reproduced rather in its entirety or in part and it may not be used for advertising. The client to whom the report is issued may, however, show or send it or a certified copy thereof prepared by the SHENZHEN TIMEWAY TESTING LABORATORIES to his customer. Supplier or others persons directly concerned. SHENZHEN TIMEWAY TESTING LABORATORIES will not, without the consent of the client enter into any discussion of correspondence with any third party concerning the contents of the report.

In the event of the improper use of the report. The SHENZHEN TIMEWAY TESTING LABORATORIES reserves the rights to withdraw it and to adopt any other remedies which may be appropriate.



Test Figure

FCC_FCC Part 15B Class B 30MHz-1GHz

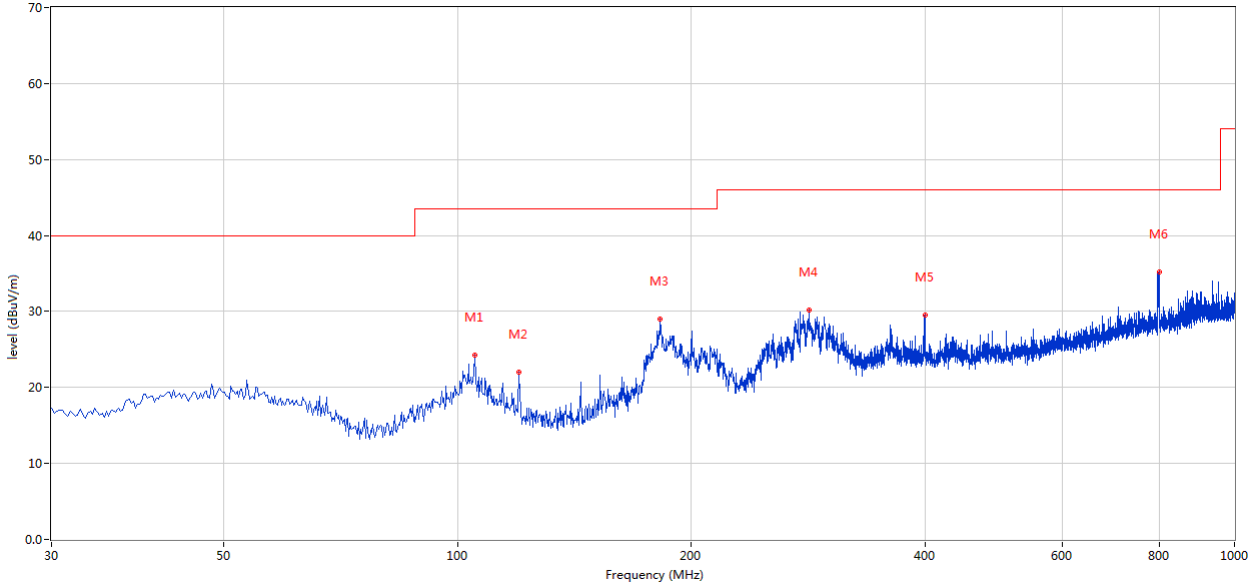

No.	Frequency (MHz)	Results (dBuV/m)	Factor (dB)	Limit (dBuV/m)	Over Limit (dB)	Detector	Table (o)	Height (cm)	ANT	Verdict
1	105.156	24.28	-13.23	43.5	-19.22	Peak	280.00	100	Horizontal	Pass
2	119.945	22.04	-15.32	43.5	-21.46	Peak	270.00	100	Horizontal	Pass
3	182.252	29.04	-15.00	43.5	-14.46	Peak	204.00	100	Horizontal	Pass
4	283.592	30.25	-11.37	46.0	-15.75	Peak	46.00	100	Horizontal	Pass
5	399.478	29.57	-8.58	46.0	-16.43	Peak	25.00	100	Horizontal	Pass
6	799.745	35.17	-2.97	46.0	-10.83	Peak	280.00	100	Horizontal	Pass

The report refers only to the sample tested and does not apply to the bulk.

This report is issued in confidence to the client and it will be strictly treated as such by the SHENZHEN TIMEWAY TESTING LABORATORIES. It may not be reproduced rather in its entirety or in part and it may not be used for advertising. The client to whom the report is issued may, however, show or send it . or a certified copy there of prepared by the SHENZHEN TIMEWAY TESTING LABORATORIES. to his customer. Supplier or others persons directly concerned. SHENZHEN TIMEWAY TESTING LABORATORIES. will not, without the consent of the client enter into any discussion of correspondence with any third party concerning the contents of the report.

In the event of the improper use of the report. The SHENZHEN TIMEWAY TESTING LABORATORIES. reserves the rights to withdraw it and to adopt any other remedies which may be appropriate.



Test Figure

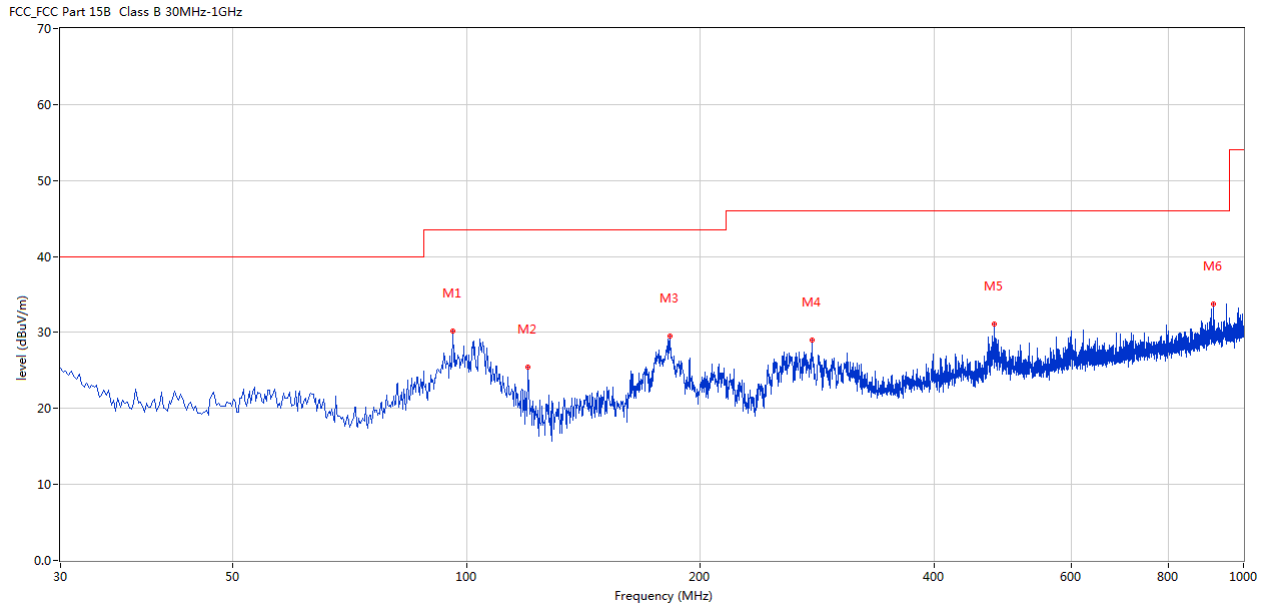

No.	Frequency (MHz)	Results (dBuV/m)	Factor (dB)	Limit (dBuV/m)	Over Limit (dB)	Detector	Table (o)	Height (cm)	ANT	Verdict
1	95.944	30.16	-14.16	43.5	-13.34	Peak	182.00	100	Vertical	Pass
2	119.945	25.46	-15.32	43.5	-18.04	Peak	134.00	100	Vertical	Pass
3	182.494	29.55	-14.98	43.5	-13.95	Peak	243.00	100	Vertical	Pass
4	278.500	28.96	-11.56	46.0	-17.04	Peak	50.00	100	Vertical	Pass
5	477.301	31.06	-7.44	46.0	-14.94	Peak	269.00	100	Vertical	Pass
6	914.176	33.72	-1.75	46.0	-12.28	Peak	8.00	100	Vertical	Pass

The report refers only to the sample tested and does not apply to the bulk.

This report is issued in confidence to the client and it will be strictly treated as such by the SHENZHEN TIMEWAY TESTING LABORATORIES. It may not be reproduced rather in its entirety or in part and it may not be used for advertising. The client to whom the report is issued may, however, show or send it . or a certified copy there of prepared by the SHENZHEN TIMEWAY TESTING LABORATORIES. to his customer. Supplier or others persons directly concerned. SHENZHEN TIMEWAY TESTING LABORATORIES. will not, without the consent of the client enter into any discussion of correspondence with any third party concerning the contents of the report.

In the event of the improper use of the report. The SHENZHEN TIMEWAY TESTING LABORATORIES. reserves the rights to withdraw it and to adopt any other remedies which may be appropriate.



Operation Mode: Keeping Transmitting under CH149 for 11g at 6Mbps

Frequency (MHz)	Level@3m (dB μ V/m)	Antenna Polarity	Limit@3m (dB μ V/m)
5745.00	91.29 (PK)	H	Fundamental Frequency
5745.00	86.51 (PK)	V	
11490	--	H/V	74(Peak)/ 54(AV)
17235	--	H/V	74(Peak)/ 54(AV)
22980	--	H/V	74(Peak)/ 54(AV)
28725	--	H/V	74(Peak)/ 54(AV)
34470	--	H/V	74(Peak)/ 54(AV)

- Note: 1. Level = Reading + AF + Cable - Preamp + Filter - Dist, Margin = Level - Limit
 2. Remark "---" means that the emissions level is too low to be measured
 3. For 802.11a mode 6Mbps

Operation Mode: Keeping Transmitting under CH157 for 11g at 6Mbps

Frequency (MHz)	Level@3m (dB μ V/m)	Antenna Polarity	Limit@3m (dB μ V/m)
5785.00	90.32 (PK)	H	Fundamental Frequency
5785.00	85.73 (PK)	V	
11570	--	H/V	74(Peak)/ 54(AV)
17355	--	H/V	74(Peak)/ 54(AV)
23140	--	H/V	74(Peak)/ 54(AV)
28925	--	H/V	74(Peak)/ 54(AV)
34710	--	H/V	74(Peak)/ 54(AV)

- Note: 1. Level = Reading + AF + Cable - Preamp + Filter - Dist, Margin = Level - Limit
 2. Remark "---" means that the emissions level is too low to be measured
 3. For 802.11a mode 6Mbps

The report refers only to the sample tested and does not apply to the bulk.
 This report is issued in confidence to the client and it will be strictly treated as such by the SHENZHEN TIMEWAY TESTING LABORATORIES. It may not be reproduced rather in its entirety or in part and it may not be used for advertising. The client to whom the report is issued may, however, show or send it, or a certified copy thereof prepared by the SHENZHEN TIMEWAY TESTING LABORATORIES, to his customer. Supplier or others persons directly concerned. SHENZHEN TIMEWAY TESTING LABORATORIES, will not, without the consent of the client enter into any discussion of correspondence with any third party concerning the contents of the report.
 In the event of the improper use of the report. The SHENZHEN TIMEWAY TESTING LABORATORIES, reserves the rights to withdraw it and to adopt any other remedies which may be appropriate.



Operation Mode: Keeping Transmitting under CH161 for 11g at 6Mbps

Frequency (MHz)	Level@3m (dB μ V/m)	Antenna Polarity	Limit@3m (dB μ V/m)
5825.00	91.43 (PK)	H	Fundamental Frequency
5825.00	86.67 (PK)	V	
11650	--	H/V	74(Peak)/ 54(AV)
17475	--	H/V	74(Peak)/ 54(AV)
23300	--	H/V	74(Peak)/ 54(AV)
29125	--	H/V	74(Peak)/ 54(AV)
34950	--	H/V	74(Peak)/ 54(AV)

- Note: 1. Level = Reading + AF + Cable - Preamp + Filter - Dist, Margin = Level - Limit
 2. Remark “---” means that the emissions level is too low to be measured
 3. For 802.11a mode 6Mbps

The report refers only to the sample tested and does not apply to the bulk.
 This report is issued in confidence to the client and it will be strictly treated as such by the SHENZHEN TIMEWAY TESTING LABORATORIES. It may not be reproduced rather in its entirety or in part and it may not be used for advertizing. The client to whom the report is issued may, however, show or send it . or a certified copy there of prepared by the SHENZHEN TIMEWAY TESTING LABORATORIES. to his customer. Supplier or others persons directly concerned. SHENZHEN TIMEWAY TESTING LABORATORIES. will not, without the consent of the client enter into any discussion of correspondence with any third party concerning the contents of the report.
 In the event of the improper use of the report. The SHENZHEN TIMEWAY TESTING LABORATORIES. reserves the rights to withdraw it and to adopt any other remedies which may be appropriate.



Restricted band Measurement			
EUT	Wireless USB Adapter		Test Mode: Channel 149 (5745MHz)-11a
Mode	Keeping Transmitting		Input Voltage DC5.0V
Temperature	24 deg. C,		Humidity 56% RH
Test Result:	Pass		Detector PK
5725	PK (dBμV/m)	53.5 (PK)	Limit -17dBm/MHz
	EIRP (dBm)	-41.7	
Polarity	Horizontal		--

Remark: 1. According to KDB 789033 D02 General UNII Test Procedures New Rules v01 section G) d) (ii), for measurement above 1000MHz@3m distance, the limit of EIRP is calculated as follows:

$$EIRP[dBm] = E[dB\mu V/m] - 95.2$$

For Example, if $E[dB\mu V/m] = 53.5 dB\mu V/m$,

$$EIRP[dBm] = E[dB\mu V/m] - 95.2 = 53.5 - 95.2 = -41.7 dBm$$

2. RBW=1MHz, VBW=3MHz

Restricted band Measurement			
EUT	Wireless USB Adapter		Test Mode: Channel 149 (5745MHz)-11a
Mode	Keeping Transmitting		Input Voltage DC5.0V
Temperature	24 deg. C,		Humidity 56% RH
Test Result:	Pass		Detector PK
5725	PK (dBμV/m)	47.2(PK)	Limit -17dBm/MHz
	EIRP (dBm)	-48.0	
Polarity	Vertical		--

Remark: 1. According to KDB 789033 D02 General UNII Test Procedures New Rules v01 section G) d) (ii), for measurement above 1000MHz@3m distance, the limit of EIRP is calculated as follows:

$$EIRP[dBm] = E[dB\mu V/m] - 95.2$$

For Example, if $E[dB\mu V/m] = 47.2 dB\mu V/m$,

$$EIRP[dBm] = E[dB\mu V/m] - 95.2 = 47.2 - 95.2 = -48.0 dBm$$

2. RBW=1MHz, VBW=3MHz

The report refers only to the sample tested and does not apply to the bulk.

This report is issued in confidence to the client and it will be strictly treated as such by the SHENZHEN TIMEWAY TESTING LABORATORIES. It may not be reproduced rather in its entirety or in part and it may not be used for advertising. The client to whom the report is issued may, however, show or send it . or a certified copy there of prepared by the SHENZHEN TIMEWAY TESTING LABORATORIES. to his customer. Supplier or others persons directly concerned. SHENZHEN TIMEWAY TESTING LABORATORIES. will not, without the consent of the client enter into any discussion of correspondence with any third party concerning the contents of the report.

In the event of the improper use of the report. The SHENZHEN TIMEWAY TESTING LABORATORIES. reserves the rights to withdraw it and to adopt any other remedies which may be appropriate.



Restricted band Measurement			
EUT	Wireless USB Adapter		Test Mode: Channel 161 (5825MHz)-11a
Mode	Keeping Transmitting		Input Voltage DC5.0V
Temperature	24 deg. C,		Humidity 56% RH
Test Result:	Pass		Detector PK
5850	PK (dBμV/m)	55.7(PK)	Limit -17dBm/MHz
	EIRP (dBm)	-39.5	
Polarity	Horizontal		--

Remark: 1. According to KDB 789033 D02 General UNII Test Procedures New Rules v01 section G) d) (ii), for measurement above 1000MHz@3m distance, the limit of EIRP is calculated as follows:

$$EIRP[dBm] = E[dB\mu V/m] - 95.2$$

For Example, if $E[dB\mu V/m] = 55.7dB\mu V/m$,

$$EIRP[dBm] = E[dB\mu V/m] - 95.2 = 55.7 - 95.2 = -39.5dBm$$

2. RBW=1MHz, VBW=3MHz

Restricted band Measurement			
EUT	Wireless USB Adapter		Test Mode: Channel 161 (5825MHz)-11a
Mode	Keeping Transmitting		Input Voltage DC5.0V
Temperature	24 deg. C,		Humidity 56% RH
Test Result:	Pass		Detector PK
5850	PK (dBμV/m)	50.9 (PK)	Limit -17dBm/MHz
	EIRP (dBm)	-44.3	
Polarity	Vertical		--

Remark: 1. According to KDB 789033 D02 General UNII Test Procedures New Rules v01 section G) d) (ii), for measurement above 1000MHz@3m distance, the limit of EIRP is calculated as follows:

$$EIRP[dBm] = E[dB\mu V/m] - 95.2$$

For Example, if $E[dB\mu V/m] = 50.9 dB\mu V/m$,

$$EIRP[dBm] = E[dB\mu V/m] - 95.2 = 50.9 - 95.2 = -44.3dBm$$

2. RBW=1MHz, VBW=3MHz

The report refers only to the sample tested and does not apply to the bulk.

This report is issued in confidence to the client and it will be strictly treated as such by the SHENZHEN TIMEWAY TESTING LABORATORIES. It may not be reproduced rather in its entirety or in part and it may not be used for advertising. The client to whom the report is issued may, however, show or send it . or a certified copy there of prepared by the SHENZHEN TIMEWAY TESTING LABORATORIES. to his customer. Supplier or others persons directly concerned. SHENZHEN TIMEWAY TESTING LABORATORIES. will not, without the consent of the client enter into any discussion of correspondence with any third party concerning the contents of the report.

In the event of the improper use of the report. The SHENZHEN TIMEWAY TESTING LABORATORIES. reserves the rights to withdraw it and to adopt any other remedies which may be appropriate.



Restricted band Measurement			
EUT	Wireless USB Adapter		Test Mode: Channel 149 (5745MHz)-11n/HT20
Mode	Keeping Transmitting		Input Voltage DC5.0V
Temperature	24 deg. C,		Humidity 56% RH
Test Result:	Pass		Detector PK
5725	PK (dBμV/m)	50.6 (PK)	Limit -17dBm/MHz
	EIRP (dBm)	-44.6	
Polarity	Horizontal		--

Remark: 1. According to KDB 789033 D02 General UNII Test Procedures New Rules v01 section G) d) (ii), for measurement above 1000MHz@3m distance, the limit of EIRP is calculated as follows:

$$EIRP[dBm] = E[dB\mu V/m] - 95.2$$

For Example, if $E[dB\mu V/m] = 50.6dB\mu V/m$,

$$EIRP[dBm] = E[dB\mu V/m] - 95.2 = 50.6 - 95.2 = -44.6dBm$$

2. RBW=1MHz, VBW=3MHz

Restricted band Measurement			
EUT	Wireless USB Adapter		Test Mode: Channel 149 (5745MHz)-11n/HT20
Mode	Keeping Transmitting		Input Voltage DC5.0V
Temperature	24 deg. C,		Humidity 56% RH
Test Result:	Pass		Detector PK
5725	PK (dBμV/m)	46.7(PK)	Limit -17dBm/MHz
	EIRP (dBm)	-48.5	
Polarity	Vertical		--

Remark: 1. According to KDB 789033 D02 General UNII Test Procedures New Rules v01 section G) d) (ii), for measurement above 1000MHz@3m distance, the limit of EIRP is calculated as follows:

$$EIRP[dBm] = E[dB\mu V/m] - 95.2$$

For Example, if $E[dB\mu V/m] = 46.7dB\mu V/m$,

$$EIRP[dBm] = E[dB\mu V/m] - 95.2 = 46.7 - 95.2 = -48.5dBm$$

2. RBW=1MHz, VBW=3MHz

The report refers only to the sample tested and does not apply to the bulk.

This report is issued in confidence to the client and it will be strictly treated as such by the SHENZHEN TIMEWAY TESTING LABORATORIES. It may not be reproduced rather in its entirety or in part and it may not be used for advertising. The client to whom the report is issued may, however, show or send it . or a certified copy there of prepared by the SHENZHEN TIMEWAY TESTING LABORATORIES. to his customer. Supplier or others persons directly concerned. SHENZHEN TIMEWAY TESTING LABORATORIES. will not, without the consent of the client enter into any discussion of correspondence with any third party concerning the contents of the report.

In the event of the improper use of the report. The SHENZHEN TIMEWAY TESTING LABORATORIES. reserves the rights to withdraw it and to adopt any other remedies which may be appropriate.



Restricted band Measurement			
EUT	Wireless USB Adapter		Test Mode: Channel 161 (5825MHz)-11n/HT20
Mode	Keeping Transmitting		Input Voltage DC5.0V
Temperature	24 deg. C,		Humidity 56% RH
Test Result:	Pass		Detector PK
5850	PK (dBμV/m)	50.1 (PK)	Limit -17dBm/MHz
	EIRP (dBm)	-45.1	
Polarity	Horizontal		--

Remark: 1. According to KDB 789033 D02 General UNII Test Procedures New Rules v01 section G) d) (ii), for measurement above 1000MHz@3m distance, the limit of EIRP is calculated as follows:

$$EIRP[dBm] = E[dB\mu V/m] - 95.2$$

For Example, if $E[dB\mu V/m] = 50.1dB\mu V/m$,

$$EIRP[dBm] = E[dB\mu V/m] - 95.2 = 50.1 - 95.2 = -45.1dBm$$

2. RBW=1MHz, VBW=3MHz

Restricted band Measurement			
EUT	Wireless USB Adapter		Test Mode: Channel 161 (5825MHz)-11n/HT20
Mode	Keeping Transmitting		Input Voltage DC5.0V
Temperature	24 deg. C,		Humidity 56% RH
Test Result:	Pass		Detector PK
5850	PK (dBμV/m)	46.6 (PK)	Limit -17dBm/MHz
	EIRP (dBm)	-48.6	
Polarity	Vertical		--

Remark: 1. According to KDB 789033 D02 General UNII Test Procedures New Rules v01 section G) d) (ii), for measurement above 1000MHz@3m distance, the limit of EIRP is calculated as follows:

$$EIRP[dBm] = E[dB\mu V/m] - 95.2$$

For Example, if $E[dB\mu V/m] = 46.6dB\mu V/m$,

$$EIRP[dBm] = E[dB\mu V/m] - 95.2 = 46.6 - 95.2 = -48.6dBm$$

2. RBW=1MHz, VBW=3MHz

The report refers only to the sample tested and does not apply to the bulk.

This report is issued in confidence to the client and it will be strictly treated as such by the SHENZHEN TIMEWAY TESTING LABORATORIES. It may not be reproduced rather in its entirety or in part and it may not be used for advertising. The client to whom the report is issued may, however, show or send it . or a certified copy there of prepared by the SHENZHEN TIMEWAY TESTING LABORATORIES. to his customer. Supplier or others persons directly concerned. SHENZHEN TIMEWAY TESTING LABORATORIES. will not, without the consent of the client enter into any discussion of correspondence with any third party concerning the contents of the report.

In the event of the improper use of the report. The SHENZHEN TIMEWAY TESTING LABORATORIES. reserves the rights to withdraw it and to adopt any other remedies which may be appropriate.



Restricted band Measurement			
EUT	Wireless USB Adapter		Test Mode: Channel 151 (5755MHz)-11n/HT40
Mode	Keeping Transmitting		Input Voltage DC5.0V
Temperature	24 deg. C,		Humidity 56% RH
Test Result:	Pass		Detector PK
5725	PK (dBμV/m)	51.4(PK)	Limit -17dBm/MHz
	EIRP (dBm)	-43.8	
Polarity	Horizontal		--

Remark: 1. According to KDB 789033 D02 General UNII Test Procedures New Rules v01 section G) d) (ii), for measurement above 1000MHz@3m distance, the limit of EIRP is calculated as follows:

$$EIRP[dBm] = E[dB\mu V/m] - 95.2$$

For Example, if $E[dB\mu V/m] = 51.4 dB\mu V/m$,

$$EIRP[dBm] = E[dB\mu V/m] - 95.2 = 51.4 - 95.2 = -43.8dBm$$

2. RBW=1MHz, VBW=3MHz

Restricted band Measurement			
EUT	Wireless USB Adapter		Test Mode: Channel 151 (5755MHz)-11n/HT40
Mode	Keeping Transmitting		Input Voltage DC5.0V
Temperature	24 deg. C,		Humidity 56% RH
Test Result:	Pass		Detector PK
5725	PK (dBμV/m)	48.5(PK)	Limit -17dBm/MHz
	EIRP (dBm)	-46.7	
Polarity	Vertical		--

Remark: 1. According to KDB 789033 D02 General UNII Test Procedures New Rules v01 section G) d) (ii), for measurement above 1000MHz@3m distance, the limit of EIRP is calculated as follows:

$$EIRP[dBm] = E[dB\mu V/m] - 95.2$$

For Example, if $E[dB\mu V/m] = 46.9dB\mu V/m$,

$$EIRP[dBm] = E[dB\mu V/m] - 95.2 = 46.9 - 95.2 = -48.3dBm$$

2. RBW=1MHz, VBW=3MHz

The report refers only to the sample tested and does not apply to the bulk.

This report is issued in confidence to the client and it will be strictly treated as such by the SHENZHEN TIMEWAY TESTING LABORATORIES. It may not be reproduced rather in its entirety or in part and it may not be used for advertising. The client to whom the report is issued may, however, show or send it . or a certified copy there of prepared by the SHENZHEN TIMEWAY TESTING LABORATORIES. to his customer. Supplier or others persons directly concerned. SHENZHEN TIMEWAY TESTING LABORATORIES. will not, without the consent of the client enter into any discussion of correspondence with any third party concerning the contents of the report.

In the event of the improper use of the report. The SHENZHEN TIMEWAY TESTING LABORATORIES. reserves the rights to withdraw it and to adopt any other remedies which may be appropriate.



Restricted band Measurement			
EUT	Wireless USB Adapter		Test Mode: Channel 159 (5795MHz)-11n/HT40
Mode	Keeping Transmitting		Input Voltage DC5.0V
Temperature	24 deg. C,		Humidity 56% RH
Test Result:	Pass		Detector PK
5850	PK (dBμV/m)	53.9 (PK)	Limit -17dBm/MHz
	EIRP (dBm)	-41.3	
Polarity	Horizontal		--

Remark: 1. According to KDB 789033 D02 General UNII Test Procedures New Rules v01 section G) d) (ii), for measurement above 1000MHz@3m distance, the limit of EIRP is calculated as follows:

$$EIRP[dBm] = E[dB\mu V/m] - 95.2$$

For Example, if $E[dB\mu V/m] = 53.9dB\mu V/m$,

$$EIRP[dBm] = E[dB\mu V/m] - 95.2 = 53.9 - 95.2 = -41.3dBm$$

2. RBW=1MHz, VBW=3MHz

Restricted band Measurement			
EUT	Wireless USB Adapter		Test Mode: Channel 159 (5795MHz)-11n/HT40
Mode	Keeping Transmitting		Input Voltage DC5.0V
Temperature	24 deg. C,		Humidity 56% RH
Test Result:	Pass		Detector PK
5850	PK (dBμV/m)	49.8(PK)	Limit -17dBm/MHz
	EIRP (dBm)	-45.4	
Polarity	Vertical		--

Remark: 1. According to KDB 789033 D02 General UNII Test Procedures New Rules v01 section G) d) (ii), for measurement above 1000MHz@3m distance, the limit of EIRP is calculated as follows:

$$EIRP[dBm] = E[dB\mu V/m] - 95.2$$

For Example, if $E[dB\mu V/m] = 49.8 dB\mu V/m$,

$$EIRP[dBm] = E[dB\mu V/m] - 95.2 = 49.8 - 95.2 = -45.4 dBm$$

2. RBW=1MHz, VBW=3MHz

The report refers only to the sample tested and does not apply to the bulk.

This report is issued in confidence to the client and it will be strictly treated as such by the SHENZHEN TIMEWAY TESTING LABORATORIES. It may not be reproduced rather in its entirety or in part and it may not be used for advertising. The client to whom the report is issued may, however, show or send it . or a certified copy there of prepared by the SHENZHEN TIMEWAY TESTING LABORATORIES. to his customer. Supplier or others persons directly concerned. SHENZHEN TIMEWAY TESTING LABORATORIES. will not, without the consent of the client enter into any discussion of correspondence with any third party concerning the contents of the report.

In the event of the improper use of the report. The SHENZHEN TIMEWAY TESTING LABORATORIES. reserves the rights to withdraw it and to adopt any other remedies which may be appropriate.



7.0 Emission Bandwidth

7.1 Test Setup

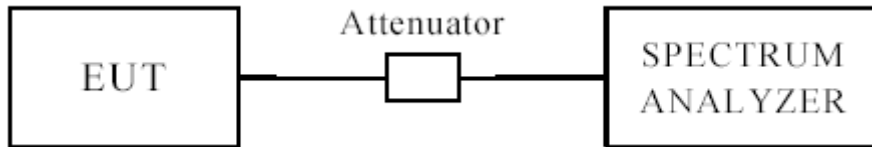

7.3 Test Procedure for Emission Bandwidth

1. Set RBW = approximately 1% of the emission bandwidth.
2. Set VBW > RBW
3. Detector = Peak.
4. Trace mode = max hold.
5. Sweep = auto couple.
6. Allow the trace to stabilize.
7. Measure the maximum width of the emission that is 26 dB down from the maximum of the emission. Compare this with the RBW setting of the analyzer. Readjust RBW and repeat measurement as needed until the RBW/EBW ratio is approximately 1%.

7.4 Test Procedure for Minimum Bandwidth for the Band 5725-5850MHz

1. Set RBW = 100 kHz.
2. Set $VBW \geq 3 \times RBW$.
3. Detector = Peak.
4. Trace mode = max hold.
5. Sweep = auto couple.
6. Allow the trace to stabilize.
7. Measure the maximum width of the emission that is constrained by the frequencies associated with the two outermost amplitude points (upper and lower frequencies) that are attenuated by 6 dB relative to the maximum level measured in the fundamental emission.

7.5 Test Procedure for 99% Bandwidth

1. Set center frequency to the nominal EUT channel center frequency
2. Set span = 1.5 times to 5.0 times OBW
3. Set RBW = 1% TO 5% of the OBW
4. Set $VBW \geq 3 \times RBW$
5. Video averaging is not permitted. Where practical, a sample detection and single sweep mode shall be used. Other, peak detection and max mode (until trace stabilizes) shall be used.
6. Use the 99% power bandwidth function of the instrument

The report refers only to the sample tested and does not apply to the bulk.

This report is issued in confidence to the client and it will be strictly treated as such by the SHENZHEN TIMEWAY TESTING LABORATORIES. It may not be reproduced rather in its entirety or in part and it may not be used for advertising. The client to whom the report is issued may, however, show or send it, or a certified copy thereof prepared by the SHENZHEN TIMEWAY TESTING LABORATORIES, to his customer. Supplier or others persons directly concerned. SHENZHEN TIMEWAY TESTING LABORATORIES, will not, without the consent of the client enter into any discussion of correspondence with any third party concerning the contents of the report.

In the event of the improper use of the report. The SHENZHEN TIMEWAY TESTING LABORATORIES, reserves the rights to withdraw it and to adopt any other remedies which may be appropriate.



7.6 Test Result

Mode	TX Type	Frequency (MHz)	ANT	99% Occupied Bandwidth (MHz)	Verdict
				Result	
802.11a	SISO	5745	1	19.746	Pass
		5785	1	19.770	Pass
		5825	1	18.886	Pass
802.11n (HT20)	SISO	5745	1	19.169	Pass
		5785	1	19.387	Pass
		5825	1	19.021	Pass
802.11n (HT40)	SISO	5755	1	38.629	Pass
		5795	1	38.390	Pass
802.11ac (VHT20)	SISO	5745	1	19.752	Pass
		5785	1	19.385	Pass
		5825	1	18.724	Pass
802.11ac (VHT40)	SISO	5755	1	37.845	Pass
		5795	1	37.834	Pass
802.11ac (VHT80)	SISO	5775	1	77.308	Pass

The report refers only to the sample tested and does not apply to the bulk.

This report is issued in confidence to the client and it will be strictly treated as such by the SHENZHEN TIMEWAY TESTING LABORATORIES. It may not be reproduced rather in its entirety or in part and it may not be used for advertising. The client to whom the report is issued may, however, show or send it or a certified copy thereof prepared by the SHENZHEN TIMEWAY TESTING LABORATORIES to his customer. Supplier or others persons directly concerned. SHENZHEN TIMEWAY TESTING LABORATORIES will not, without the consent of the client enter into any discussion of correspondence with any third party concerning the contents of the report.

In the event of the improper use of the report. The SHENZHEN TIMEWAY TESTING LABORATORIES reserves the rights to withdraw it and to adopt any other remedies which may be appropriate.

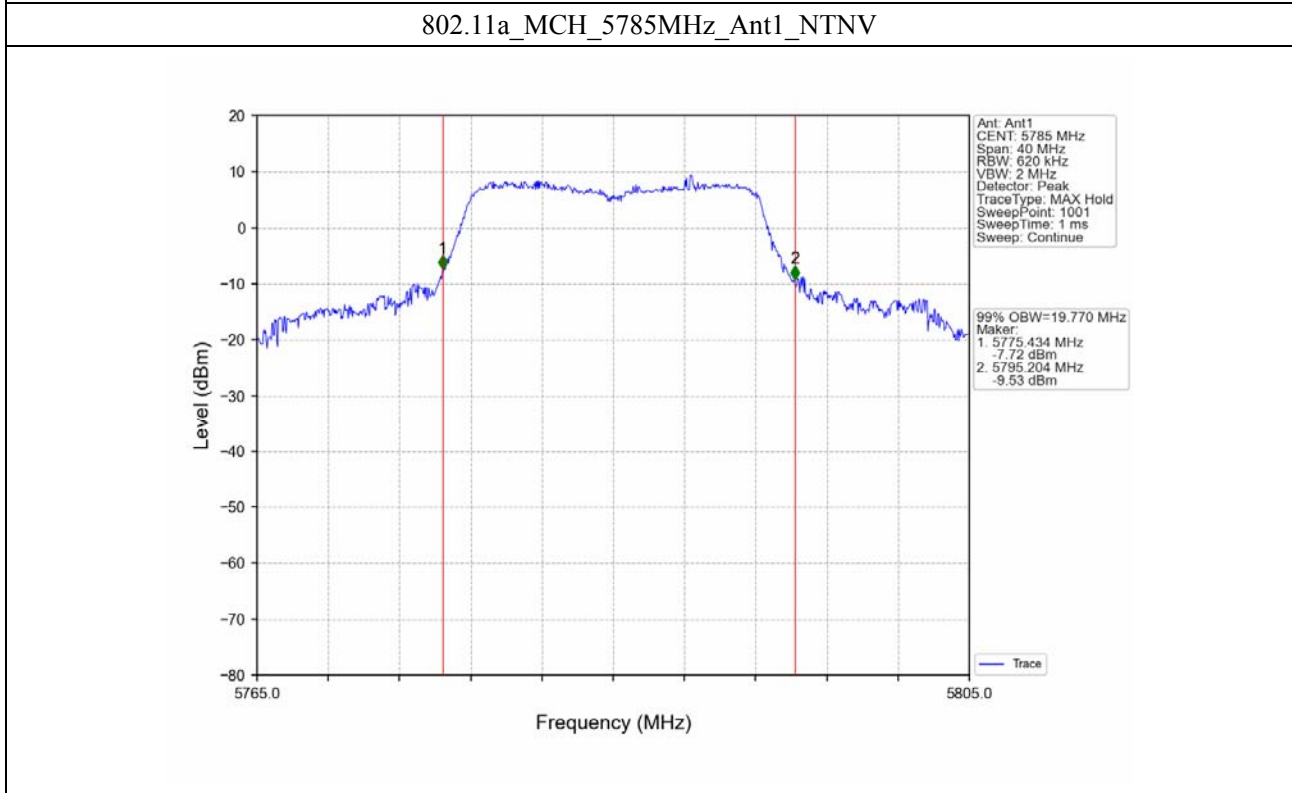
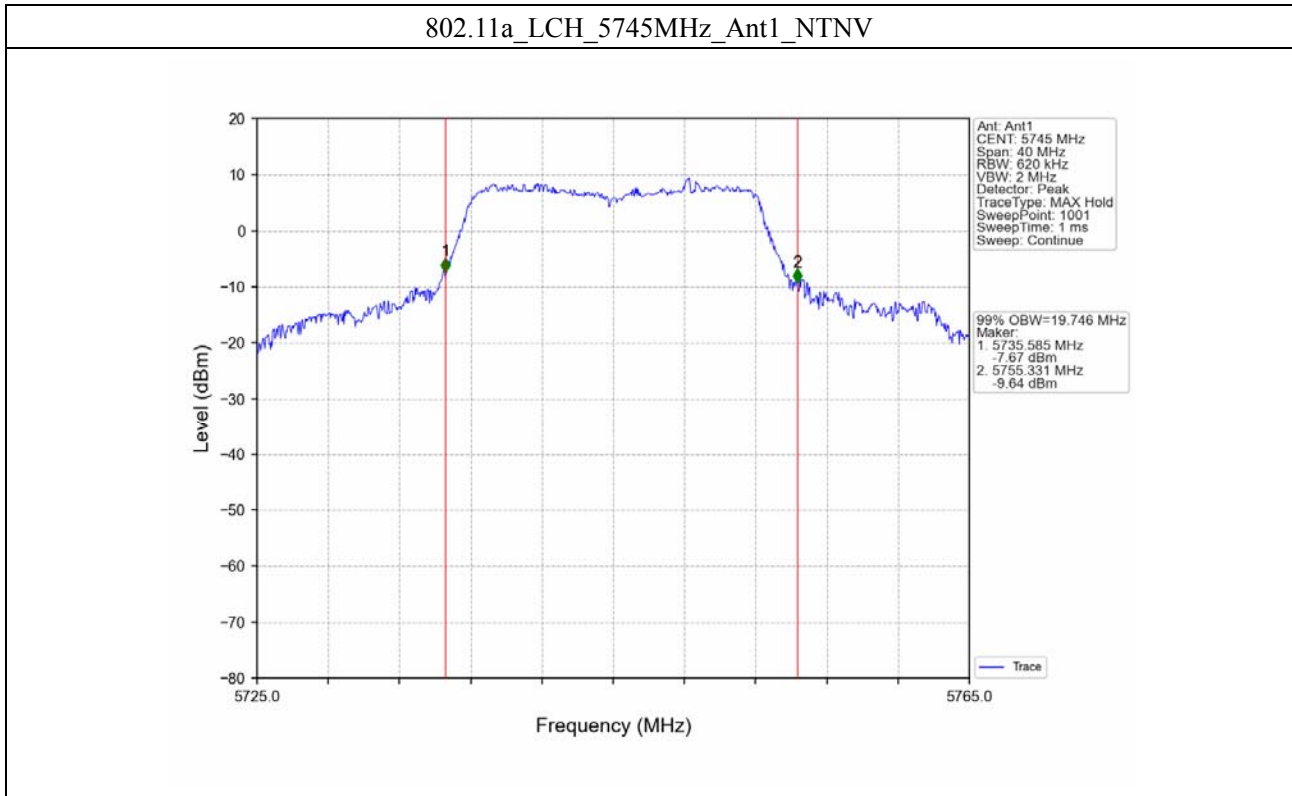

The report refers only to the sample tested and does not apply to the bulk.
 This report is issued in confidence to the client and it will be strictly treated as such by the SHENZHEN TIMEWAY TESTING LABORATORIES. It may not be reproduced rather in its entirety or in part and it may not be used for advertising. The client to whom the report is issued may, however, show or send it . or a certified copy there of prepared by the SHENZHEN TIMEWAY TESTING LABORATORIES. to his customer. Supplier or others persons directly concerned. SHENZHEN TIMEWAY TESTING LABORATORIES. will not, without the consent of the client enter into any discussion of correspondence with any third party concerning the contents of the report.
 In the event of the improper use of the report. The SHENZHEN TIMEWAY TESTING LABORATORIES. reserves the rights to withdraw it and to adopt any other remedies which may be appropriate.



802.11a_HCH_5825MHz_Ant1_NTNV

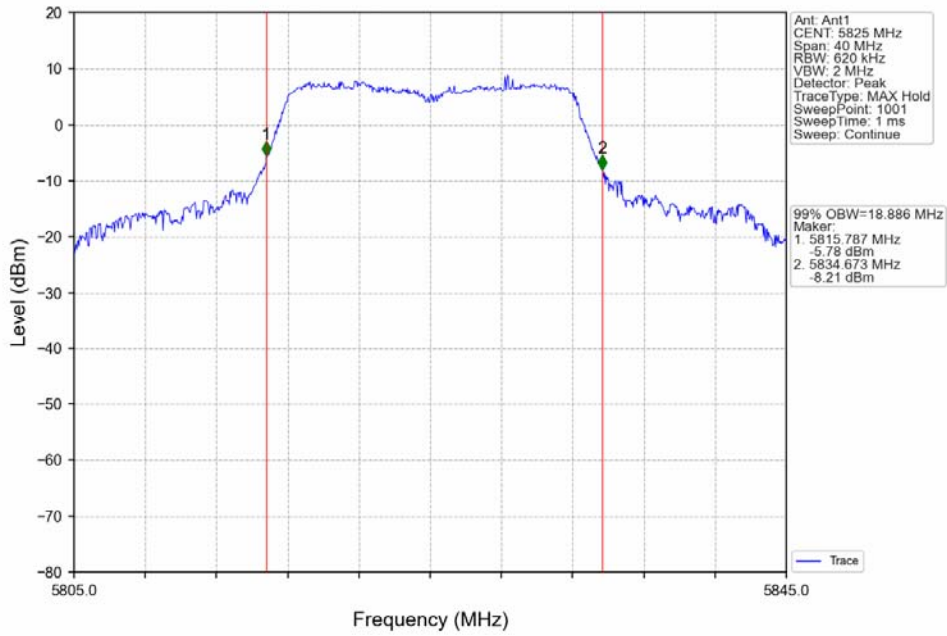

802.11n(HT20)_LCH_5745MHz_Ant1_NTNV

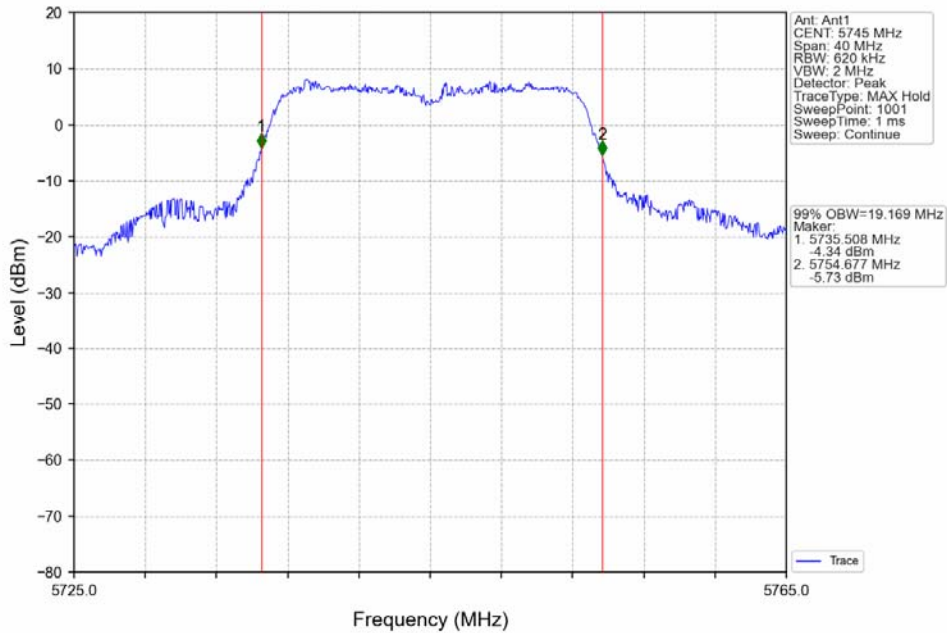

The report refers only to the sample tested and does not apply to the bulk.

This report is issued in confidence to the client and it will be strictly treated as such by the SHENZHEN TIMEWAY TESTING LABORATORIES. It may not be reproduced rather in its entirety or in part and it may not be used for advertising. The client to whom the report is issued may, however, show or send it . or a certified copy there of prepared by the SHENZHEN TIMEWAY TESTING LABORATORIES. to his customer. Supplier or others persons directly concerned. SHENZHEN TIMEWAY TESTING LABORATORIES. will not, without the consent of the client enter into any discussion of correspondence with any third party concerning the contents of the report.

In the event of the improper use of the report. The SHENZHEN TIMEWAY TESTING LABORATORIES. reserves the rights to withdraw it and to adopt any other remedies which may be appropriate.



802.11n(HT20)_MCH_5785MHz_Ant1_NTNV

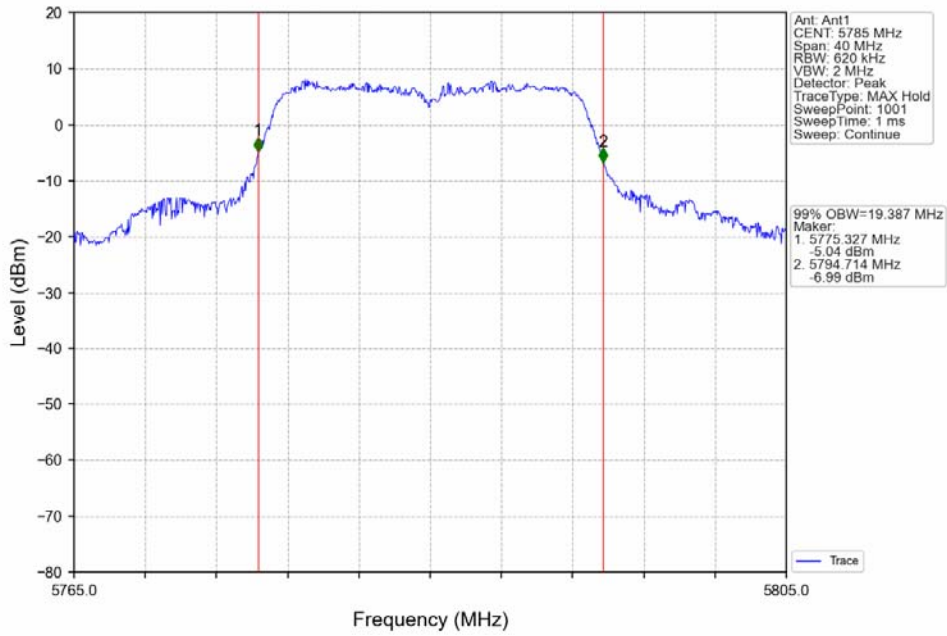

802.11n(HT20)_HCH_5825MHz_Ant1_NTNV

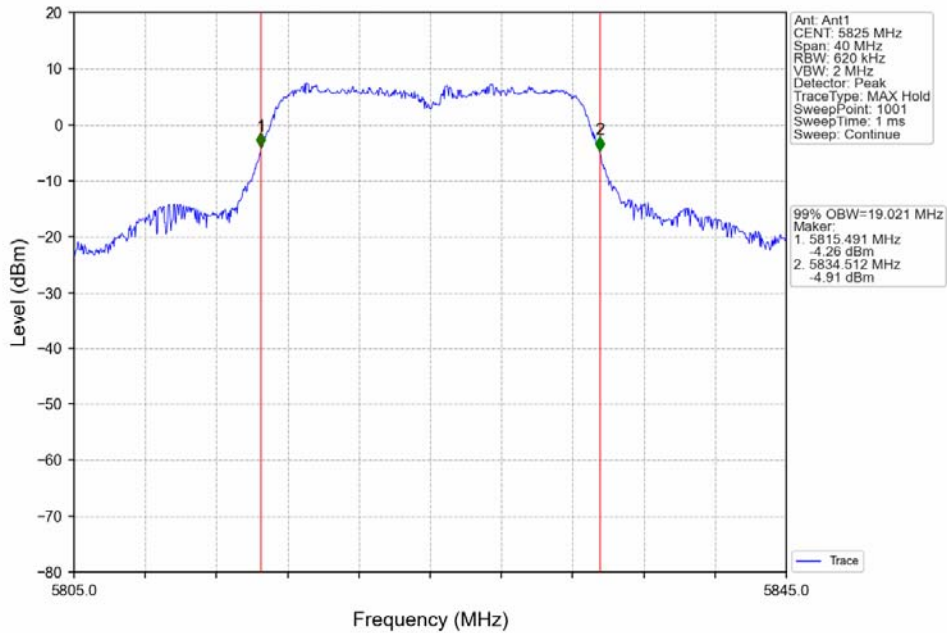

The report refers only to the sample tested and does not apply to the bulk.

This report is issued in confidence to the client and it will be strictly treated as such by the SHENZHEN TIMEWAY TESTING LABORATORIES. It may not be reproduced rather in its entirety or in part and it may not be used for advertising. The client to whom the report is issued may, however, show or send it . or a certified copy there of prepared by the SHENZHEN TIMEWAY TESTING LABORATORIES. to his customer. Supplier or others persons directly concerned. SHENZHEN TIMEWAY TESTING LABORATORIES. will not, without the consent of the client enter into any discussion of correspondence with any third party concerning the contents of the report.

In the event of the improper use of the report. The SHENZHEN TIMEWAY TESTING LABORATORIES. reserves the rights to withdraw it and to adopt any other remedies which may be appropriate.

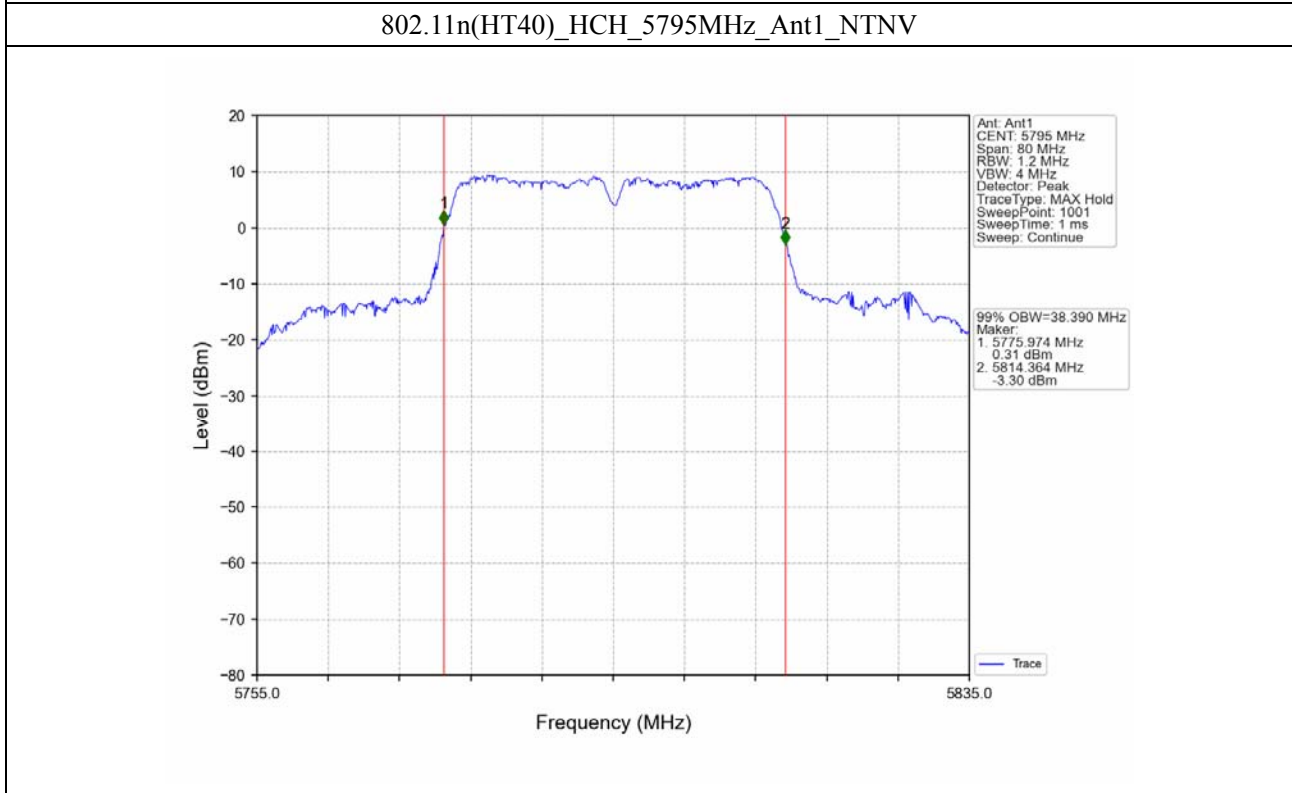
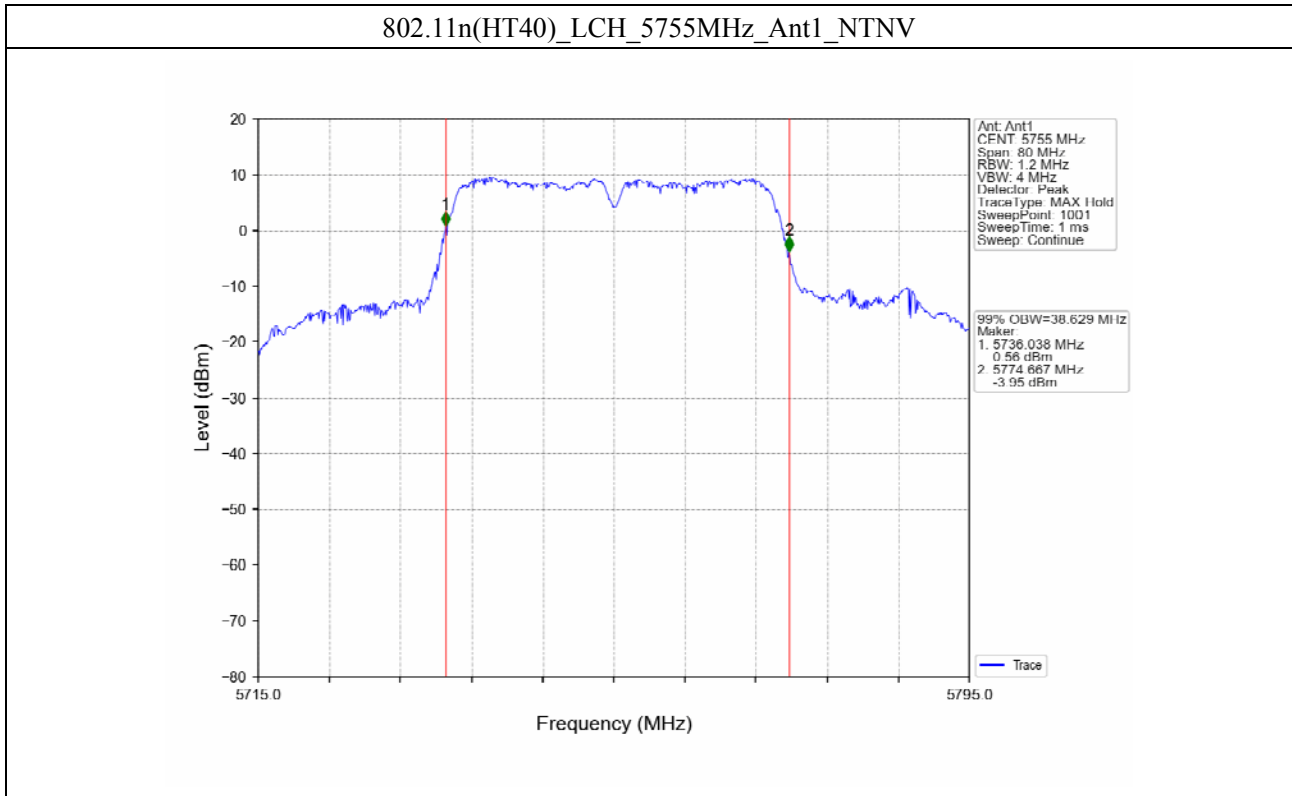

The report refers only to the sample tested and does not apply to the bulk.
 This report is issued in confidence to the client and it will be strictly treated as such by the SHENZHEN TIMEWAY TESTING LABORATORIES. It may not be reproduced rather in its entirety or in part and it may not be used for advertising. The client to whom the report is issued may, however, show or send it . or a certified copy there of prepared by the SHENZHEN TIMEWAY TESTING LABORATORIES. to his customer. Supplier or others persons directly concerned. SHENZHEN TIMEWAY TESTING LABORATORIES. will not, without the consent of the client enter into any discussion of correspondence with any third party concerning the contents of the report.
 In the event of the improper use of the report. The SHENZHEN TIMEWAY TESTING LABORATORIES. reserves the rights to withdraw it and to adopt any other remedies which may be appropriate.



802.11ac(VHT20)_LCH_5745MHz_Ant1_NTNV

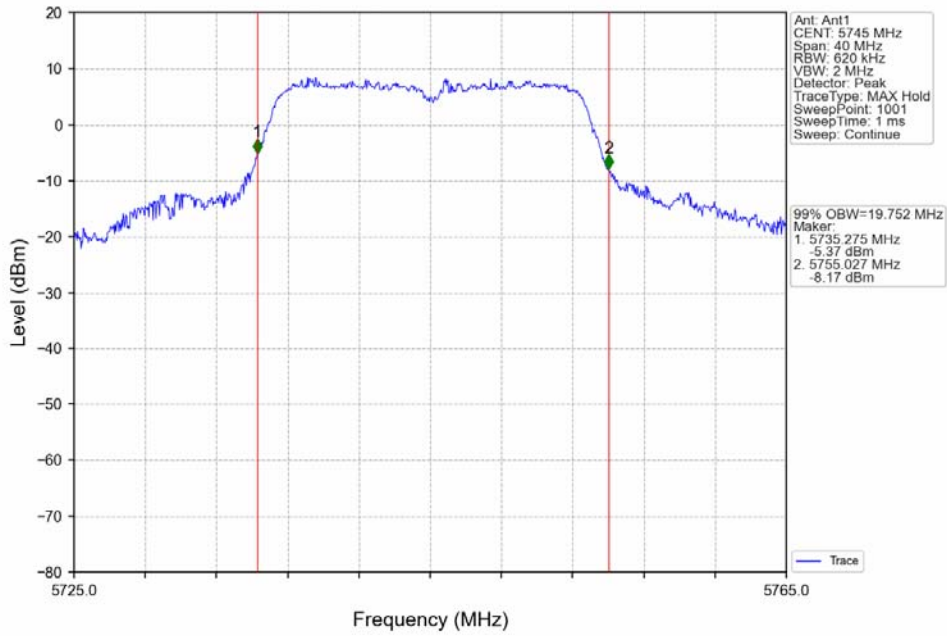

802.11ac(VHT20)_MCH_5785MHz_Ant1_NTNV

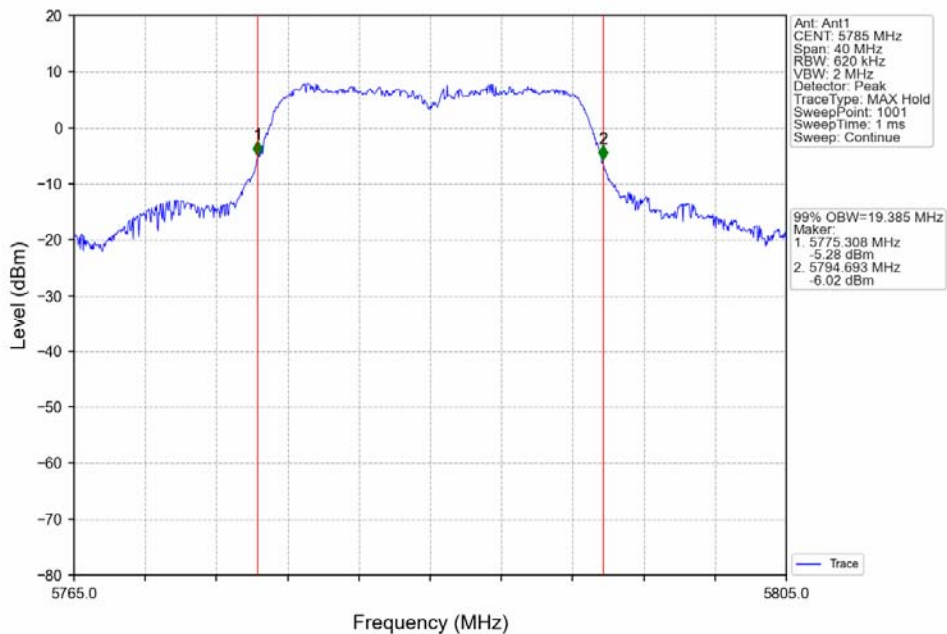

The report refers only to the sample tested and does not apply to the bulk.

This report is issued in confidence to the client and it will be strictly treated as such by the SHENZHEN TIMEWAY TESTING LABORATORIES. It may not be reproduced rather in its entirety or in part and it may not be used for advertising. The client to whom the report is issued may, however, show or send it . or a certified copy there of prepared by the SHENZHEN TIMEWAY TESTING LABORATORIES. to his customer. Supplier or others persons directly concerned. SHENZHEN TIMEWAY TESTING LABORATORIES. will not, without the consent of the client enter into any discussion of correspondence with any third party concerning the contents of the report.

In the event of the improper use of the report. The SHENZHEN TIMEWAY TESTING LABORATORIES. reserves the rights to withdraw it and to adopt any other remedies which may be appropriate.



802.11ac(VHT20)_HCH_5825MHz_Ant1_NTNV

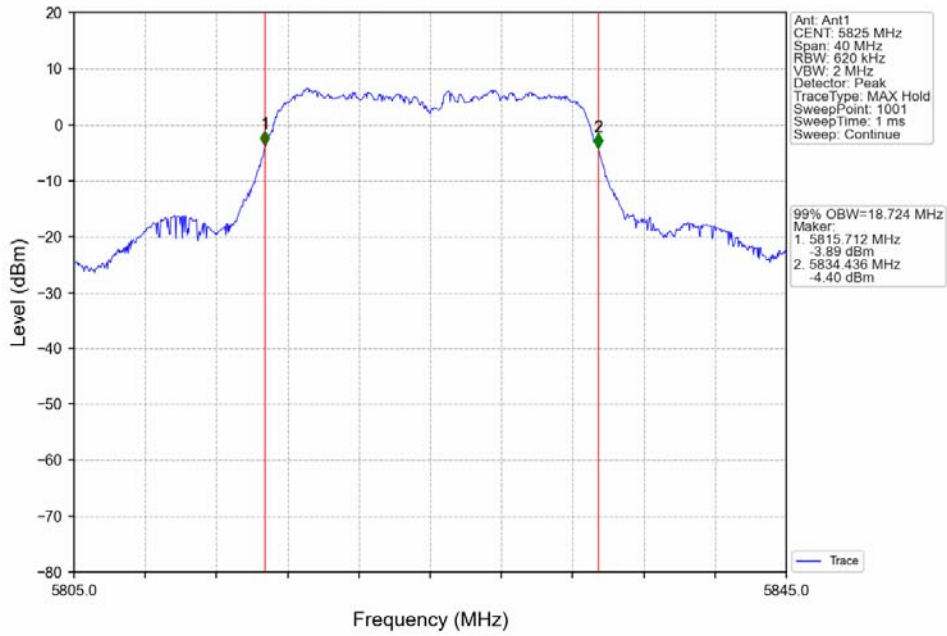

802.11ac(VHT40)_LCH_5755MHz_Ant1_NTNV

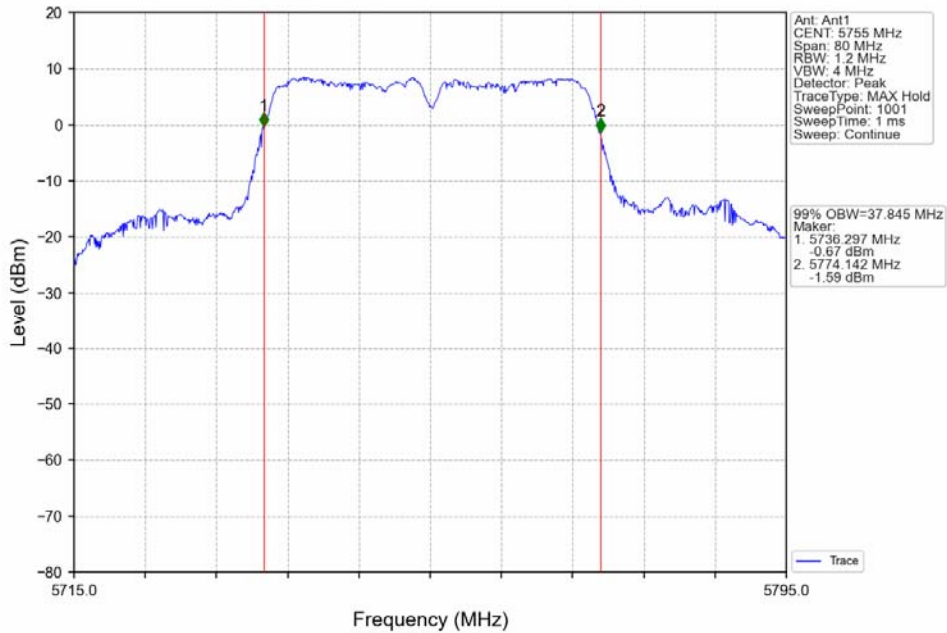

The report refers only to the sample tested and does not apply to the bulk.

This report is issued in confidence to the client and it will be strictly treated as such by the SHENZHEN TIMEWAY TESTING LABORATORIES. It may not be reproduced rather in its entirety or in part and it may not be used for advertising. The client to whom the report is issued may, however, show or send it . or a certified copy there of prepared by the SHENZHEN TIMEWAY TESTING LABORATORIES. to his customer. Supplier or others persons directly concerned. SHENZHEN TIMEWAY TESTING LABORATORIES. will not, without the consent of the client enter into any discussion of correspondence with any third party concerning the contents of the report.

In the event of the improper use of the report. The SHENZHEN TIMEWAY TESTING LABORATORIES. reserves the rights to withdraw it and to adopt any other remedies which may be appropriate.



802.11ac(VHT40)_HCH_5795MHz_Ant1_NTNV

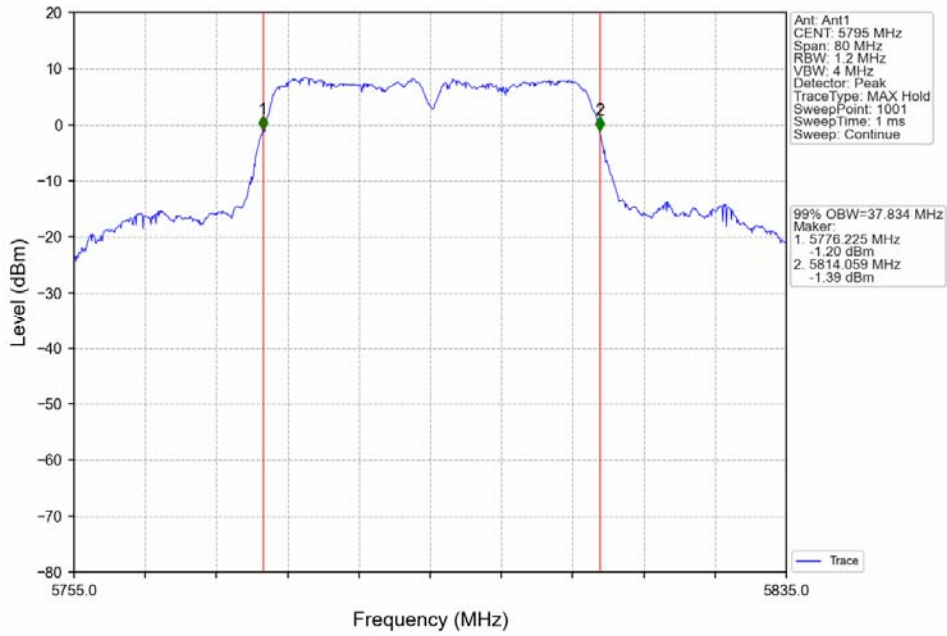

802.11ac(VHT80)_MCH_5775MHz_Ant1_NTNV

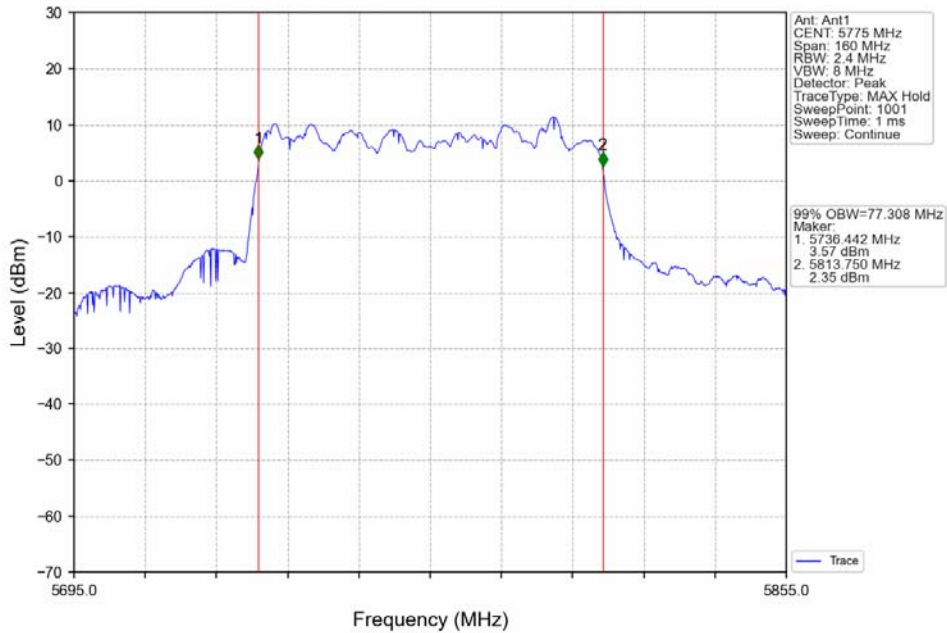

The report refers only to the sample tested and does not apply to the bulk.

This report is issued in confidence to the client and it will be strictly treated as such by the SHENZHEN TIMEWAY TESTING LABORATORIES. It may not be reproduced rather in its entirety or in part and it may not be used for advertising. The client to whom the report is issued may, however, show or send it . or a certified copy there of prepared by the SHENZHEN TIMEWAY TESTING LABORATORIES. to his customer. Supplier or others persons directly concerned. SHENZHEN TIMEWAY TESTING LABORATORIES. will not, without the consent of the client enter into any discussion of correspondence with any third party concerning the contents of the report.

In the event of the improper use of the report. The SHENZHEN TIMEWAY TESTING LABORATORIES. reserves the rights to withdraw it and to adopt any other remedies which may be appropriate.



Mode	TX Type	Frequency (MHz)	ANT	6dB Bandwidth (MHz)		Verdict
				Result	Limit	
802.11a	SISO	5745	1	16.383	≥ 0.5	Pass
		5785	1	16.363	≥ 0.5	Pass
		5825	1	16.364	≥ 0.5	Pass
802.11n (HT20)	SISO	5745	1	17.054	≥ 0.5	Pass
		5785	1	17.059	≥ 0.5	Pass
		5825	1	17.066	≥ 0.5	Pass
802.11n (HT40)	SISO	5755	1	35.795	≥ 0.5	Pass
		5795	1	35.543	≥ 0.5	Pass
802.11ac (VHT20)	SISO	5745	1	17.062	≥ 0.5	Pass
		5785	1	16.859	≥ 0.5	Pass
		5825	1	17.142	≥ 0.5	Pass
802.11ac (VHT40)	SISO	5755	1	35.815	≥ 0.5	Pass
		5795	1	35.679	≥ 0.5	Pass
802.11ac (VHT80)	SISO	5775	1	75.217	≥ 0.5	Pass

The report refers only to the sample tested and does not apply to the bulk.

This report is issued in confidence to the client and it will be strictly treated as such by the SHENZHEN TIMEWAY TESTING LABORATORIES. It may not be reproduced either in its entirety or in part and it may not be used for advertising. The client to whom the report is issued may, however, show or send it, or a certified copy thereof prepared by the SHENZHEN TIMEWAY TESTING LABORATORIES, to his customer, supplier or other persons directly concerned. SHENZHEN TIMEWAY TESTING LABORATORIES will not, without the consent of the client enter into any discussion of correspondence with any third party concerning the contents of the report.

In the event of the improper use of the report, the SHENZHEN TIMEWAY TESTING LABORATORIES reserves the rights to withdraw it and to adopt any other remedies which may be appropriate.

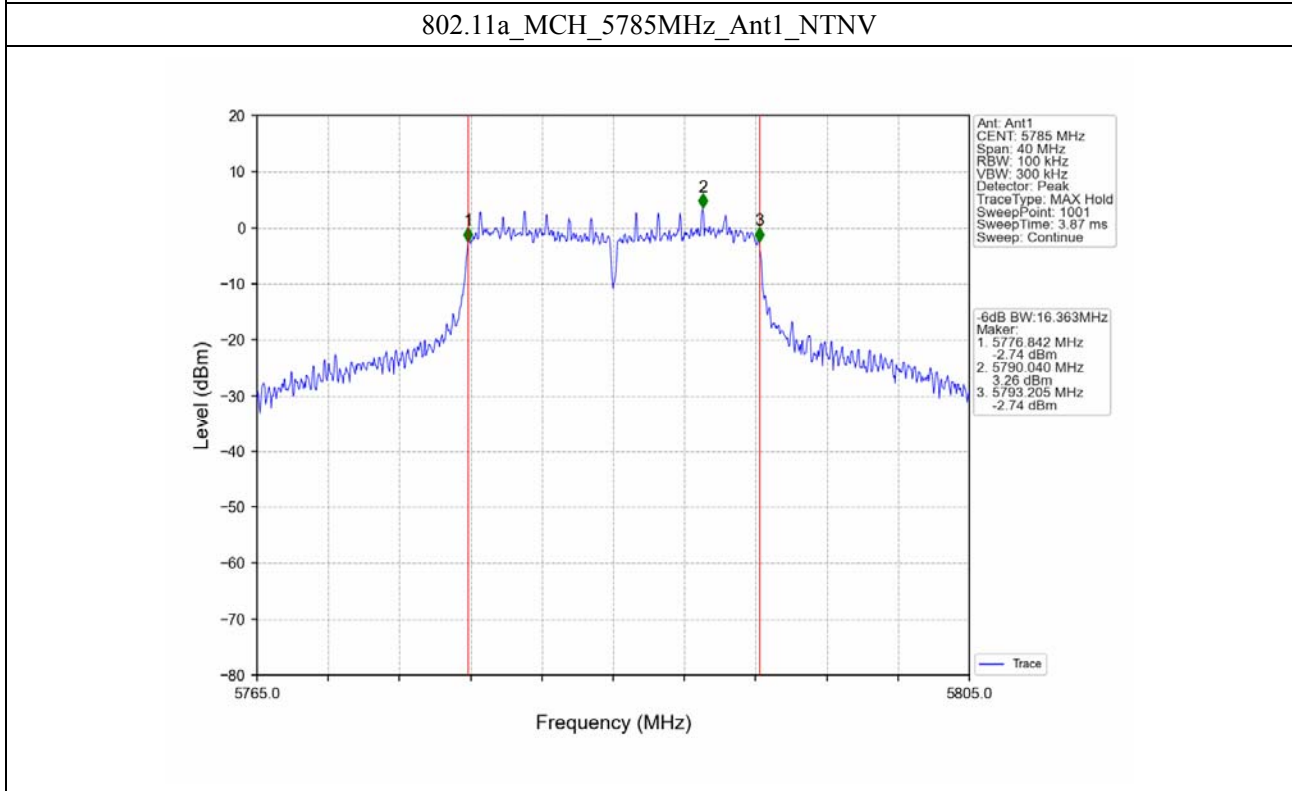
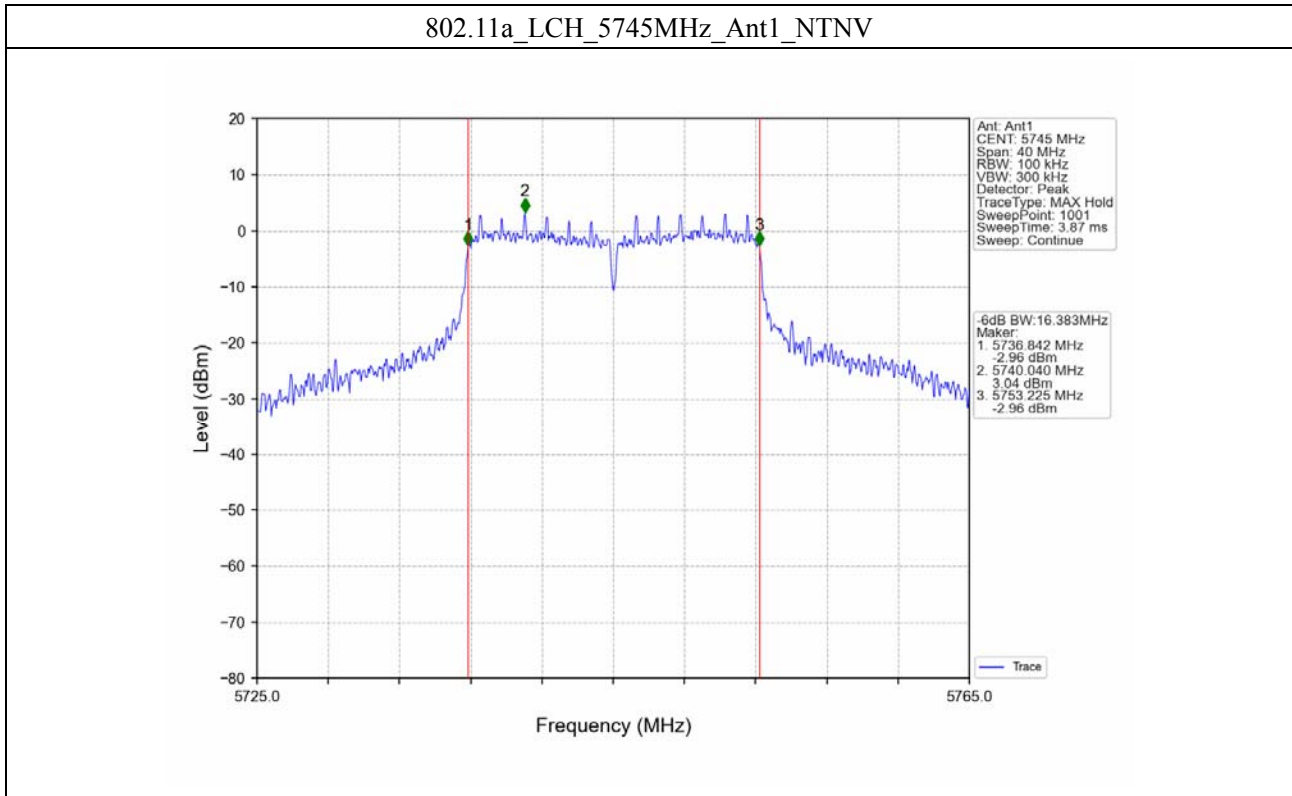

The report refers only to the sample tested and does not apply to the bulk.
 This report is issued in confidence to the client and it will be strictly treated as such by the SHENZHEN TIMEWAY TESTING LABORATORIES. It may not be reproduced rather in its entirety or in part and it may not be used for advertising. The client to whom the report is issued may, however, show or send it . or a certified copy there of prepared by the SHENZHEN TIMEWAY TESTING LABORATORIES. to his customer. Supplier or others persons directly concerned. SHENZHEN TIMEWAY TESTING LABORATORIES. will not, without the consent of the client enter into any discussion of correspondence with any third party concerning the contents of the report.
 In the event of the improper use of the report. The SHENZHEN TIMEWAY TESTING LABORATORIES. reserves the rights to withdraw it and to adopt any other remedies which may be appropriate.

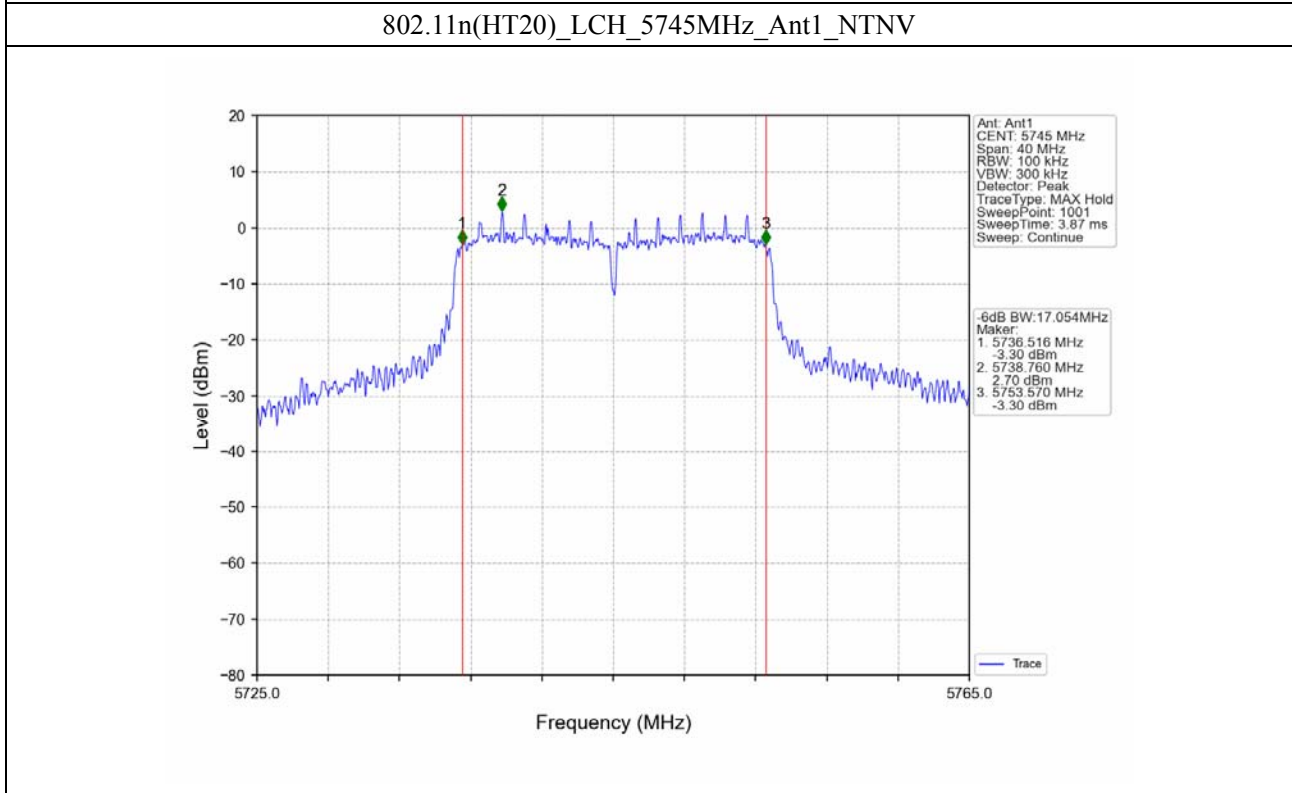
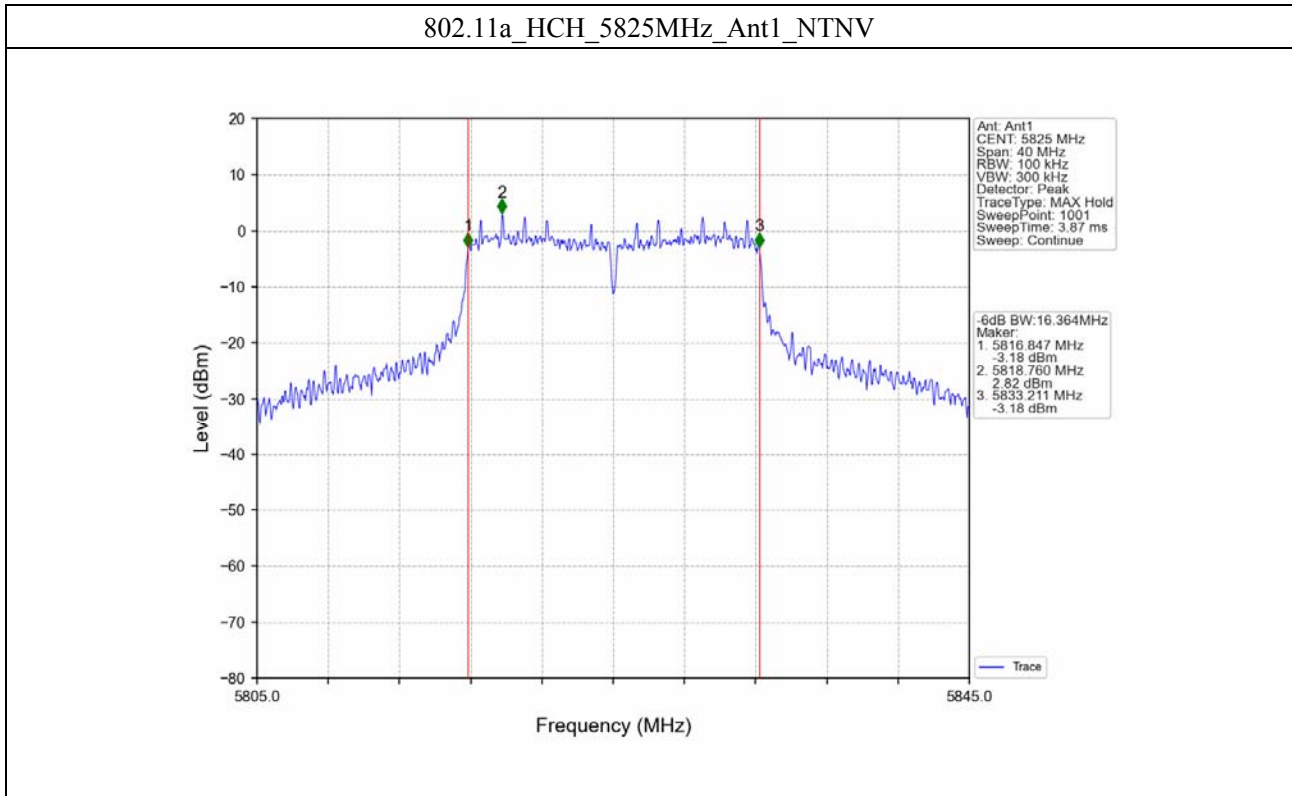

The report refers only to the sample tested and does not apply to the bulk.
 This report is issued in confidence to the client and it will be strictly treated as such by the SHENZHEN TIMEWAY TESTING LABORATORIES. It may not be reproduced rather in its entirety or in part and it may not be used for advertising. The client to whom the report is issued may, however, show or send it . or a certified copy there of prepared by the SHENZHEN TIMEWAY TESTING LABORATORIES. to his customer. Supplier or others persons directly concerned. SHENZHEN TIMEWAY TESTING LABORATORIES. will not, without the consent of the client enter into any discussion of correspondence with any third party concerning the contents of the report.
 In the event of the improper use of the report. The SHENZHEN TIMEWAY TESTING LABORATORIES. reserves the rights to withdraw it and to adopt any other remedies which may be appropriate.



802.11n(HT20)_MCH_5785MHz_Ant1_NTNV

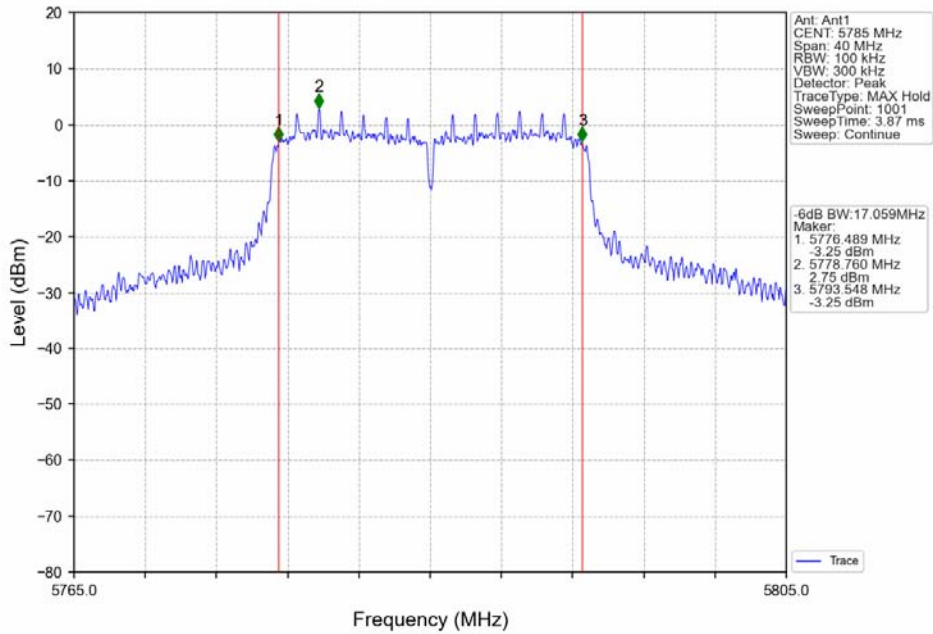

802.11n(HT20)_HCH_5825MHz_Ant1_NTNV

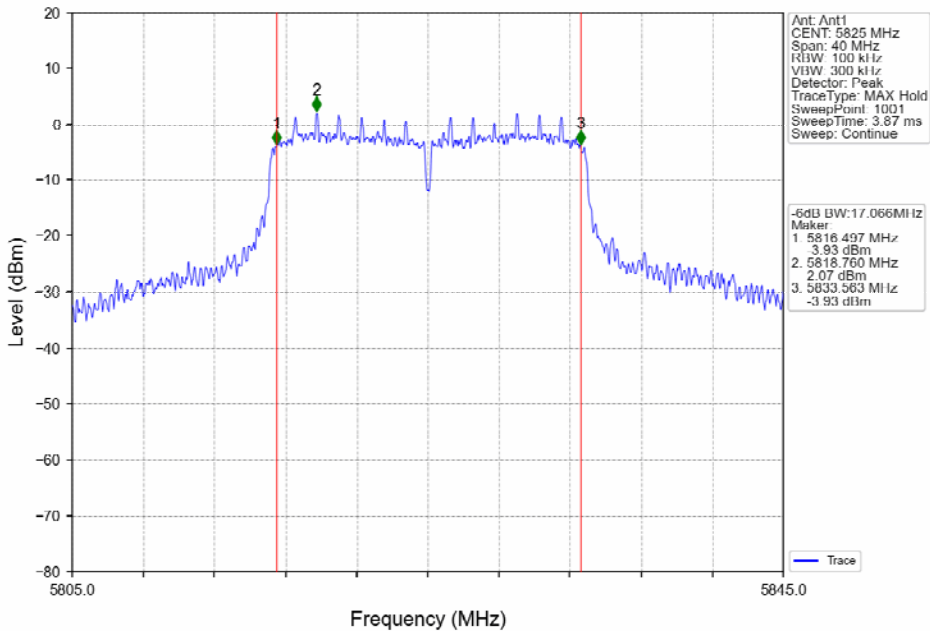

The report refers only to the sample tested and does not apply to the bulk.

This report is issued in confidence to the client and it will be strictly treated as such by the SHENZHEN TIMEWAY TESTING LABORATORIES. It may not be reproduced rather in its entirety or in part and it may not be used for advertising. The client to whom the report is issued may, however, show or send it or a certified copy thereof prepared by the SHENZHEN TIMEWAY TESTING LABORATORIES to his customer. Supplier or others persons directly concerned. SHENZHEN TIMEWAY TESTING LABORATORIES will not, without the consent of the client enter into any discussion of correspondence with any third party concerning the contents of the report.

In the event of the improper use of the report. The SHENZHEN TIMEWAY TESTING LABORATORIES reserves the rights to withdraw it and to adopt any other remedies which may be appropriate.



802.11n(HT40)_LCH_5755MHz_Ant1_NTNV

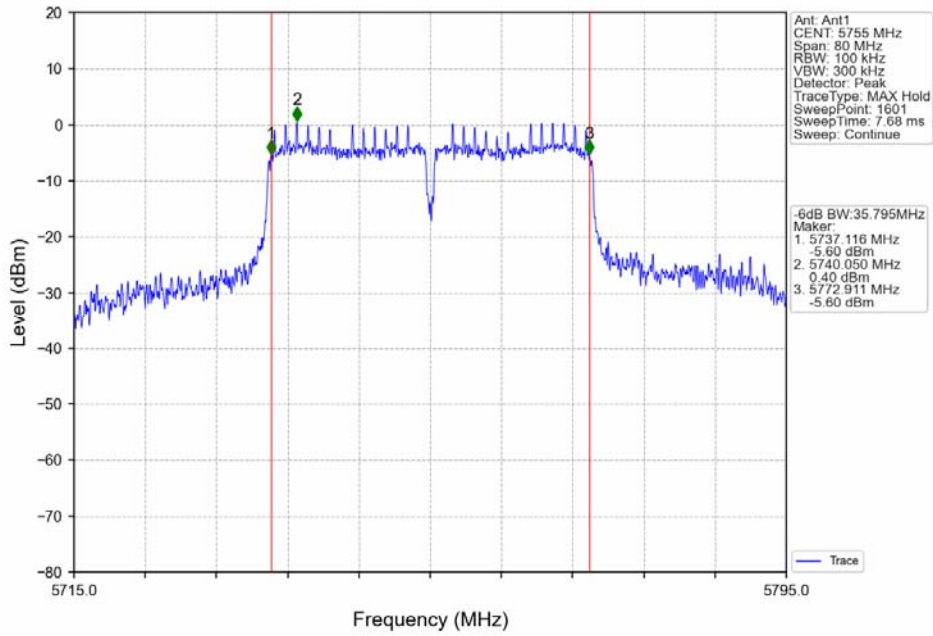

802.11n(HT40)_HCH_5795MHz_Ant1_NTNV

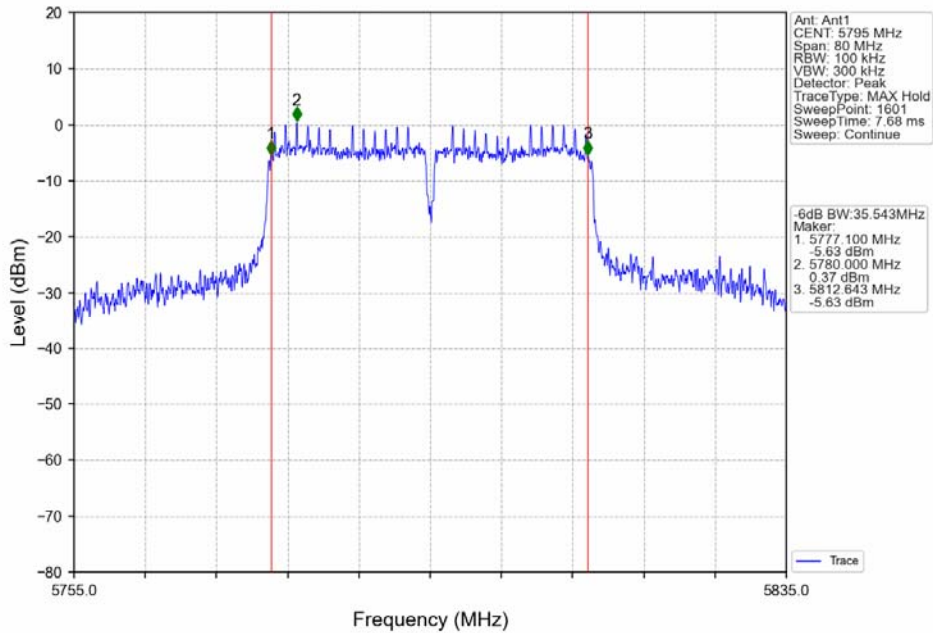

The report refers only to the sample tested and does not apply to the bulk.

This report is issued in confidence to the client and it will be strictly treated as such by the SHENZHEN TIMEWAY TESTING LABORATORIES. It may not be reproduced rather in its entirety or in part and it may not be used for advertising. The client to whom the report is issued may, however, show or send it . or a certified copy there of prepared by the SHENZHEN TIMEWAY TESTING LABORATORIES. to his customer. Supplier or others persons directly concerned. SHENZHEN TIMEWAY TESTING LABORATORIES. will not, without the consent of the client enter into any discussion of correspondence with any third party concerning the contents of the report.

In the event of the improper use of the report. The SHENZHEN TIMEWAY TESTING LABORATORIES. reserves the rights to withdraw it and to adopt any other remedies which may be appropriate.



802.11ac(VHT20)_LCH_5745MHz_Ant1_NTNV

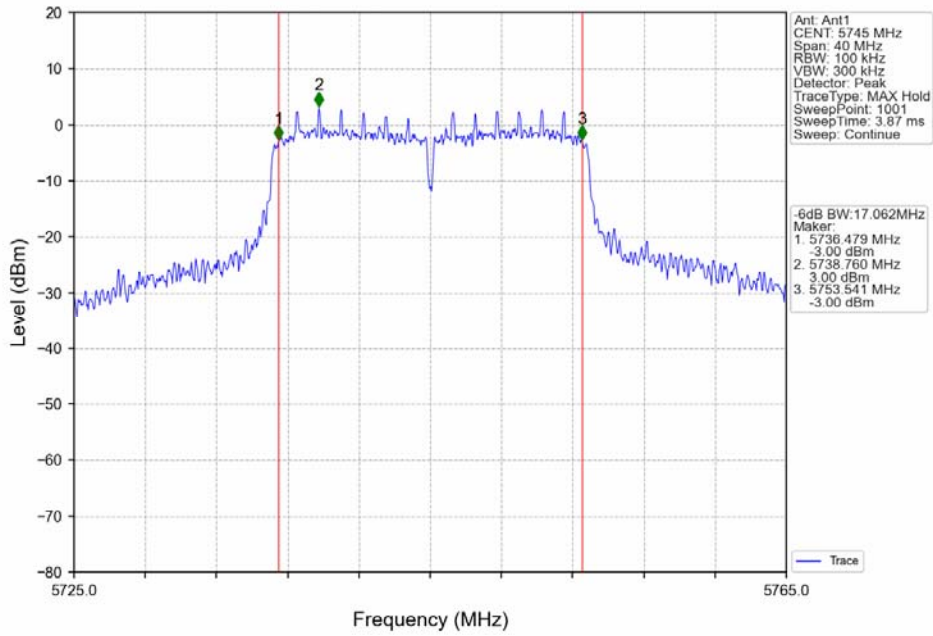

802.11ac(VHT20)_MCH_5785MHz_Ant1_NTNV

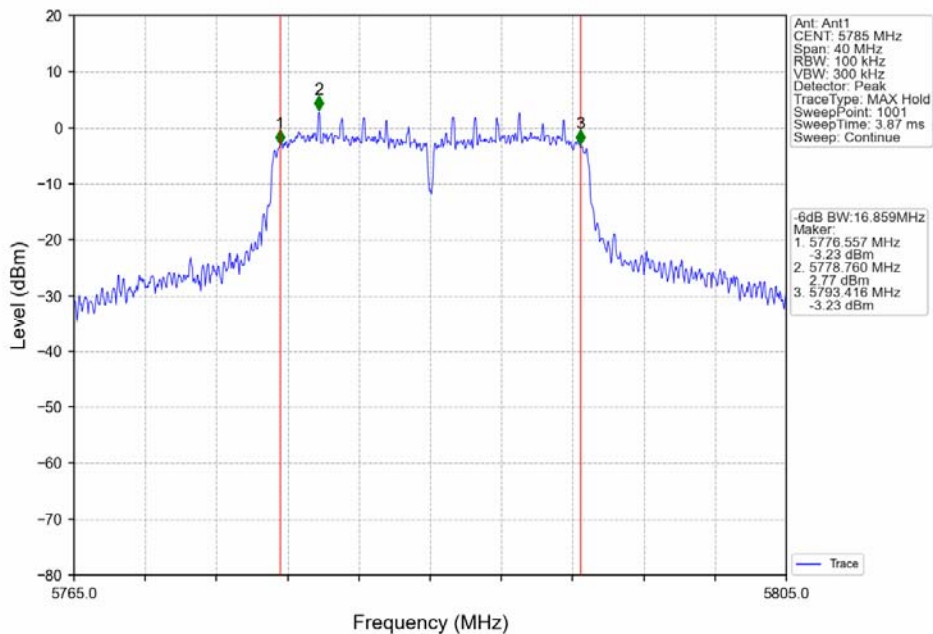

The report refers only to the sample tested and does not apply to the bulk.

This report is issued in confidence to the client and it will be strictly treated as such by the SHENZHEN TIMEWAY TESTING LABORATORIES. It may not be reproduced rather in its entirety or in part and it may not be used for advertising. The client to whom the report is issued may, however, show or send it . or a certified copy there of prepared by the SHENZHEN TIMEWAY TESTING LABORATORIES. to his customer. Supplier or others persons directly concerned. SHENZHEN TIMEWAY TESTING LABORATORIES. will not, without the consent of the client enter into any discussion of correspondence with any third party concerning the contents of the report.

In the event of the improper use of the report. The SHENZHEN TIMEWAY TESTING LABORATORIES. reserves the rights to withdraw it and to adopt any other remedies which may be appropriate.



802.11ac(VHT20)_HCH_5825MHz_Ant1_NTNV

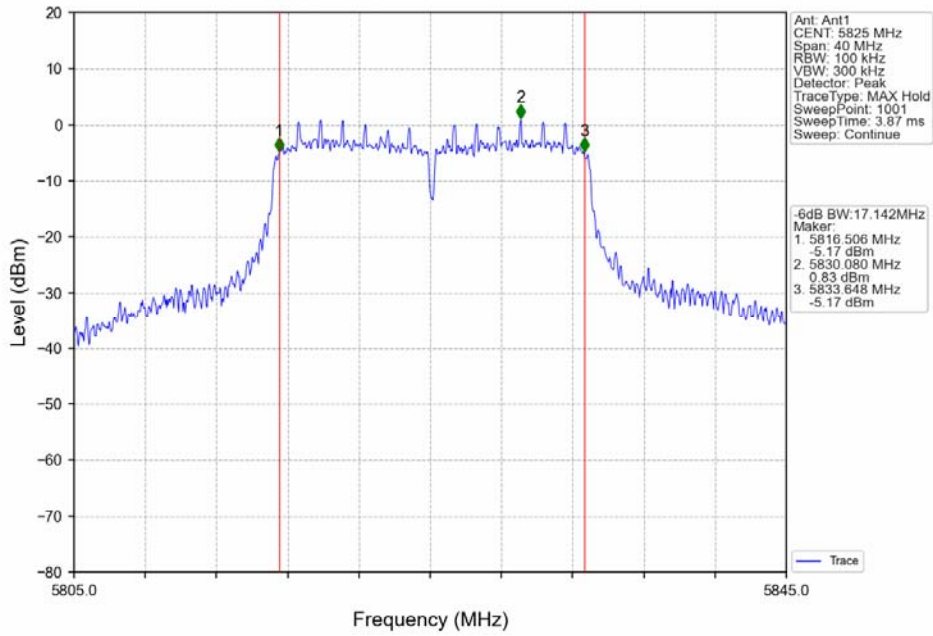

802.11ac(VHT40)_LCH_5755MHz_Ant1_NTNV

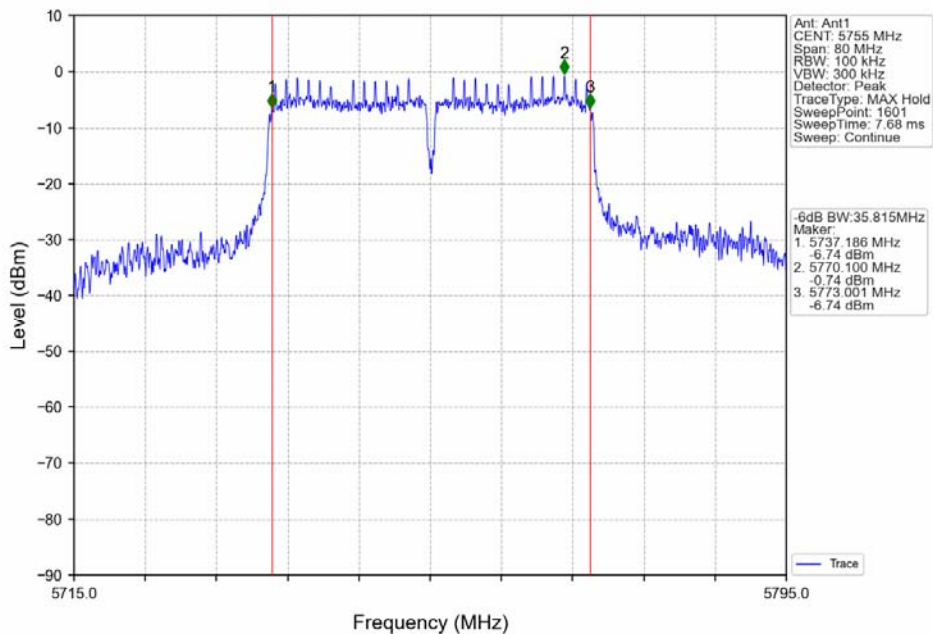

The report refers only to the sample tested and does not apply to the bulk.

This report is issued in confidence to the client and it will be strictly treated as such by the SHENZHEN TIMEWAY TESTING LABORATORIES. It may not be reproduced rather in its entirety or in part and it may not be used for advertising. The client to whom the report is issued may, however, show or send it . or a certified copy there of prepared by the SHENZHEN TIMEWAY TESTING LABORATORIES. to his customer. Supplier or others persons directly concerned. SHENZHEN TIMEWAY TESTING LABORATORIES. will not, without the consent of the client enter into any discussion of correspondence with any third party concerning the contents of the report.

In the event of the improper use of the report. The SHENZHEN TIMEWAY TESTING LABORATORIES. reserves the rights to withdraw it and to adopt any other remedies which may be appropriate.



802.11ac(VHT40)_HCH_5795MHz_Ant1_NTNV

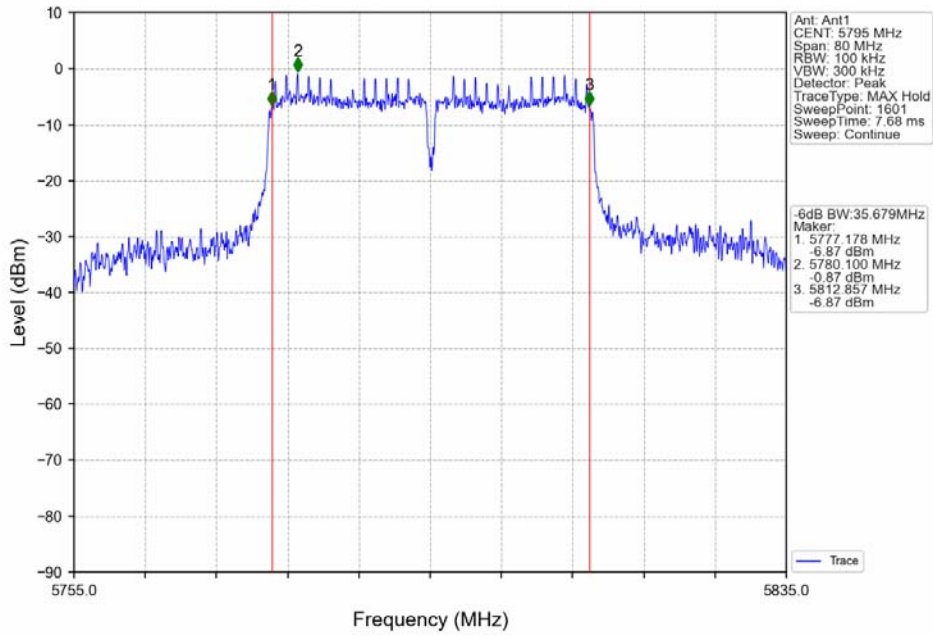

802.11ac(VHT80)_MCH_5775MHz_Ant1_NTNV

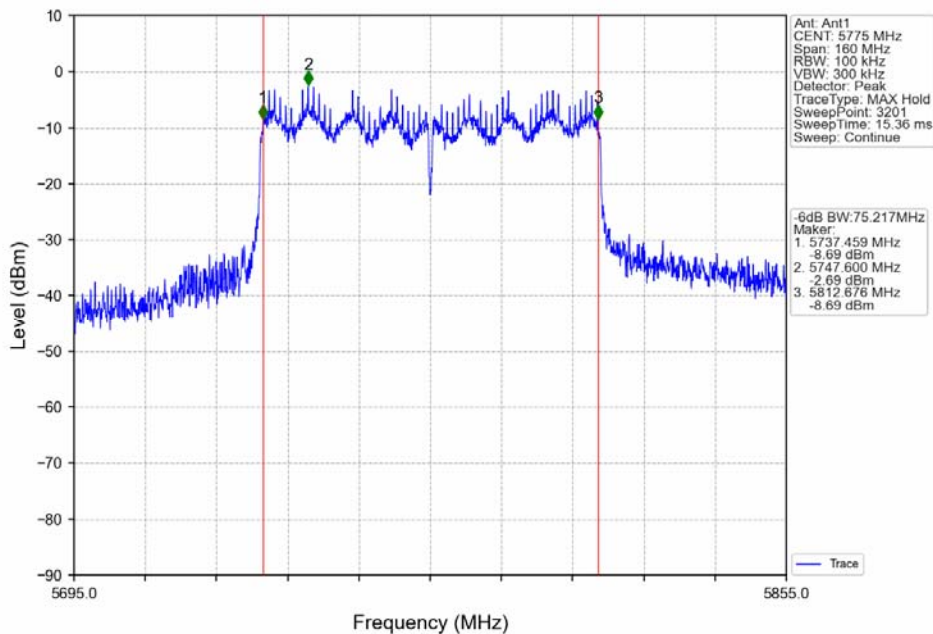

The report refers only to the sample tested and does not apply to the bulk.

This report is issued in confidence to the client and it will be strictly treated as such by the SHENZHEN TIMEWAY TESTING LABORATORIES. It may not be reproduced rather in its entirety or in part and it may not be used for advertising. The client to whom the report is issued may, however, show or send it . or a certified copy there of prepared by the SHENZHEN TIMEWAY TESTING LABORATORIES. to his customer. Supplier or others persons directly concerned. SHENZHEN TIMEWAY TESTING LABORATORIES. will not, without the consent of the client enter into any discussion of correspondence with any third party concerning the contents of the report.

In the event of the improper use of the report. The SHENZHEN TIMEWAY TESTING LABORATORIES. reserves the rights to withdraw it and to adopt any other remedies which may be appropriate.



8.0 Peak Transmit Power Measurement

8.1 Test Setup

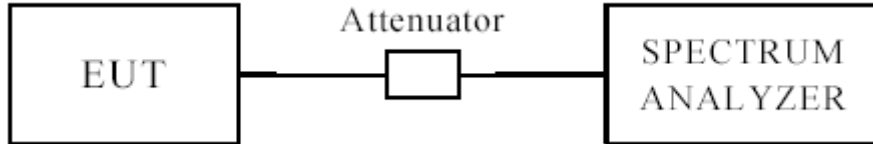

8.2 Limits of Peak Transmit Power Measurement

Operation Band	EUT Category		Limit
U-NII-1		Outdoor Access Point	1 Watt (30 dBm) \cong (Max. e.i.r.p 125mW (21 dBm) at any elevation angle above 30 degrees as measured from the horizon)
		Fixed point-to-point Access Point	1 Watt (30 dBm)
		Indoor Access Point	1 Watt (30 dBm)
	√	Client device	250mW (24 dBm)
U-NII-2A	--		250mW (24 dBm) or 11 dBm+10 log B*
U-NII-2C	--		250mW (24 dBm) or 11 dBm+10 log B*
U-NII-3	--		1 Watt (30 dBm)

Note: Where B is the 26dB emission bandwidth in MHz.

8.3 Test Procedure

The average power output was measured with a Spectrum analyzer connected to the RF Antenna connector (conducted measurement) while EUT was operating in transmit mode at the appropriate centre frequency.

Note: the average power was measured

The report refers only to the sample tested and does not apply to the bulk.

This report is issued in confidence to the client and it will be strictly treated as such by the SHENZHEN TIMEWAY TESTING LABORATORIES. It may not be reproduced rather in its entirety or in part and it may not be used for advertising. The client to whom the report is issued may, however, show or send it, or a certified copy thereof prepared by the SHENZHEN TIMEWAY TESTING LABORATORIES, to his customer. Supplier or others persons directly concerned. SHENZHEN TIMEWAY TESTING LABORATORIES, will not, without the consent of the client enter into any discussion of correspondence with any third party concerning the contents of the report.

In the event of the improper use of the report. The SHENZHEN TIMEWAY TESTING LABORATORIES, reserves the rights to withdraw it and to adopt any other remedies which may be appropriate.



8.4 Test Results

Mode	TX Type	Frequency (MHz)	Maximum Average Conducted Output Power (dBm)		Verdict
			ANT1	Limit	
802.11a	SISO	5745	14.24	<=30	Pass
		5785	14.12	<=30	Pass
		5825	13.59	<=30	Pass
802.11n (HT20)	SISO	5745	13.57	<=30	Pass
		5785	13.50	<=30	Pass
		5825	13.01	<=30	Pass
802.11n (HT40)	SISO	5755	14.48	<=30	Pass
		5795	14.28	<=30	Pass
802.11ac (VHT20)	SISO	5745	13.79	<=30	Pass
		5785	13.50	<=30	Pass
		5825	11.92	<=30	Pass
802.11ac (VHT40)	SISO	5755	13.36	<=30	Pass
		5795	13.17	<=30	Pass
802.11ac (VHT80)	SISO	5775	13.57	<=30	Pass

- Note: 1. At final test to get the worst-case emission at 6Mbps for CH149, CH157 and CH161
 2. The result basic equation calculation as follow:
 Average Power Output = AV Power Reading + Cable loss + Attenuator
 3. The worst cases were recorded

The report refers only to the sample tested and does not apply to the bulk.
 This report is issued in confidence to the client and it will be strictly treated as such by the SHENZHEN TIMEWAY TESTING LABORATORIES. It may not be reproduced rather in its entirety or in part and it may not be used for advertizing. The client to whom the report is issued may, however, show or send it . or a certified copy there of prepared by the SHENZHEN TIMEWAY TESTING LABORATORIES. to his customer. Supplier or others persons directly concerned. SHENZHEN TIMEWAY TESTING LABORATORIES. will not, without the consent of the client enter into any discussion of correspondence with any third party concerning the contents of the report.
 In the event of the improper use of the report. The SHENZHEN TIMEWAY TESTING LABORATORIES. reserves the rights to withdraw it and to adopt any other remedies which may be appropriate.

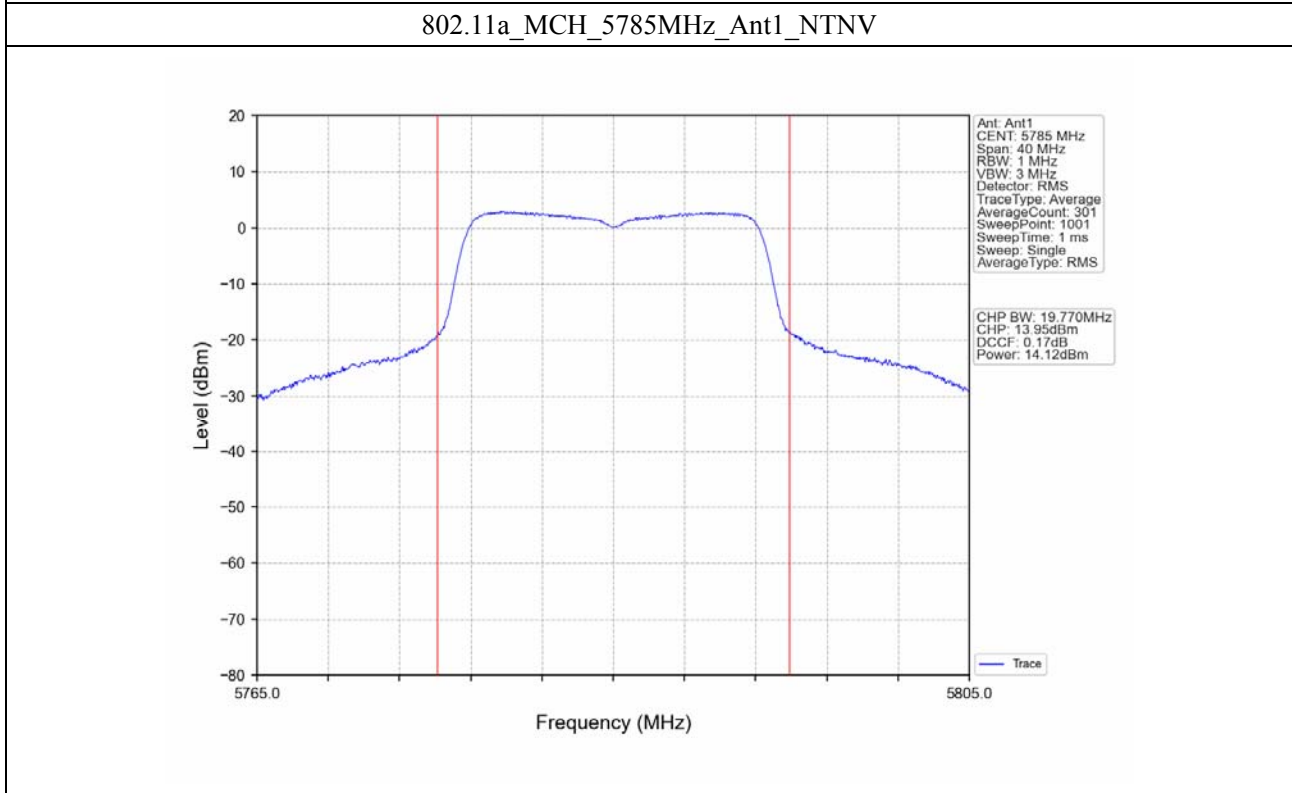
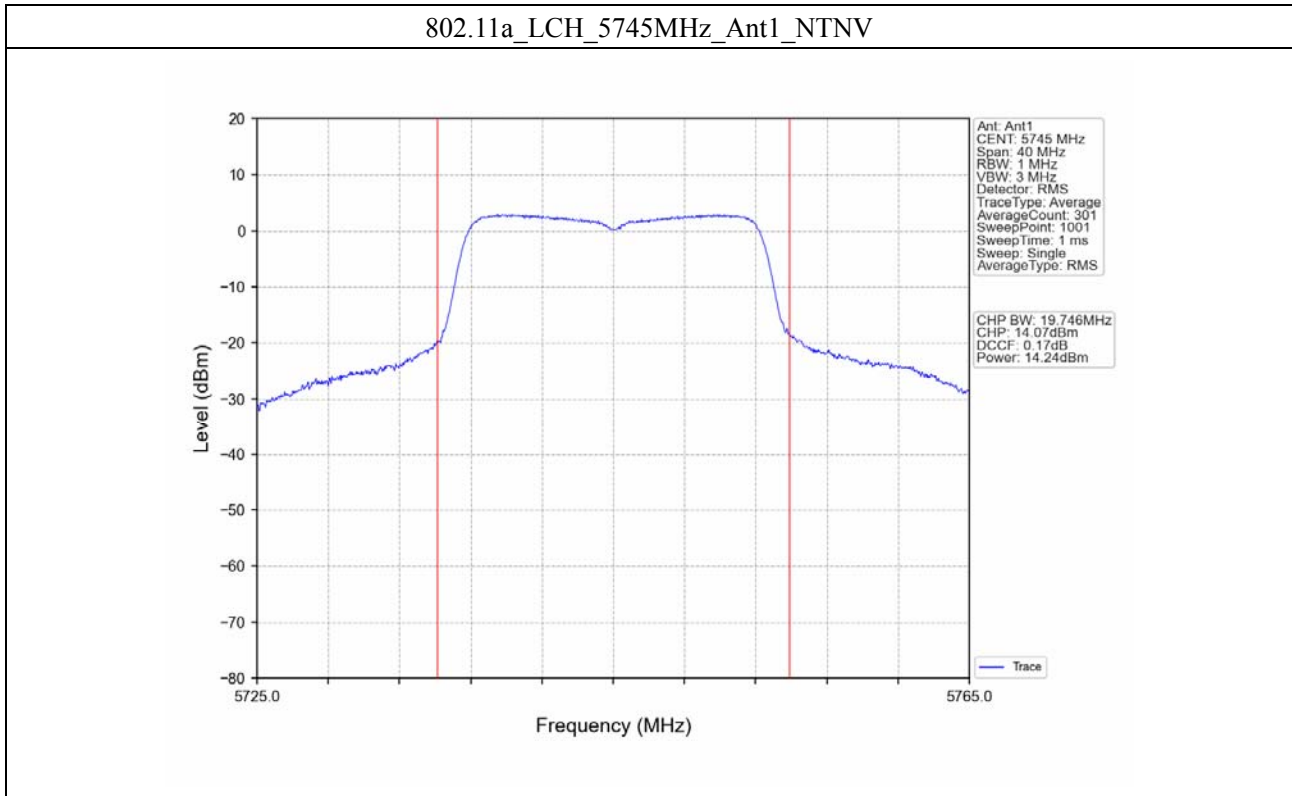

The report refers only to the sample tested and does not apply to the bulk.
 This report is issued in confidence to the client and it will be strictly treated as such by the SHENZHEN TIMEWAY TESTING LABORATORIES. It may not be reproduced rather in its entirety or in part and it may not be used for advertising. The client to whom the report is issued may, however, show or send it . or a certified copy there of prepared by the SHENZHEN TIMEWAY TESTING LABORATORIES. to his customer. Supplier or others persons directly concerned. SHENZHEN TIMEWAY TESTING LABORATORIES. will not, without the consent of the client enter into any discussion of correspondence with any third party concerning the contents of the report.
 In the event of the improper use of the report. The SHENZHEN TIMEWAY TESTING LABORATORIES. reserves the rights to withdraw it and to adopt any other remedies which may be appropriate.

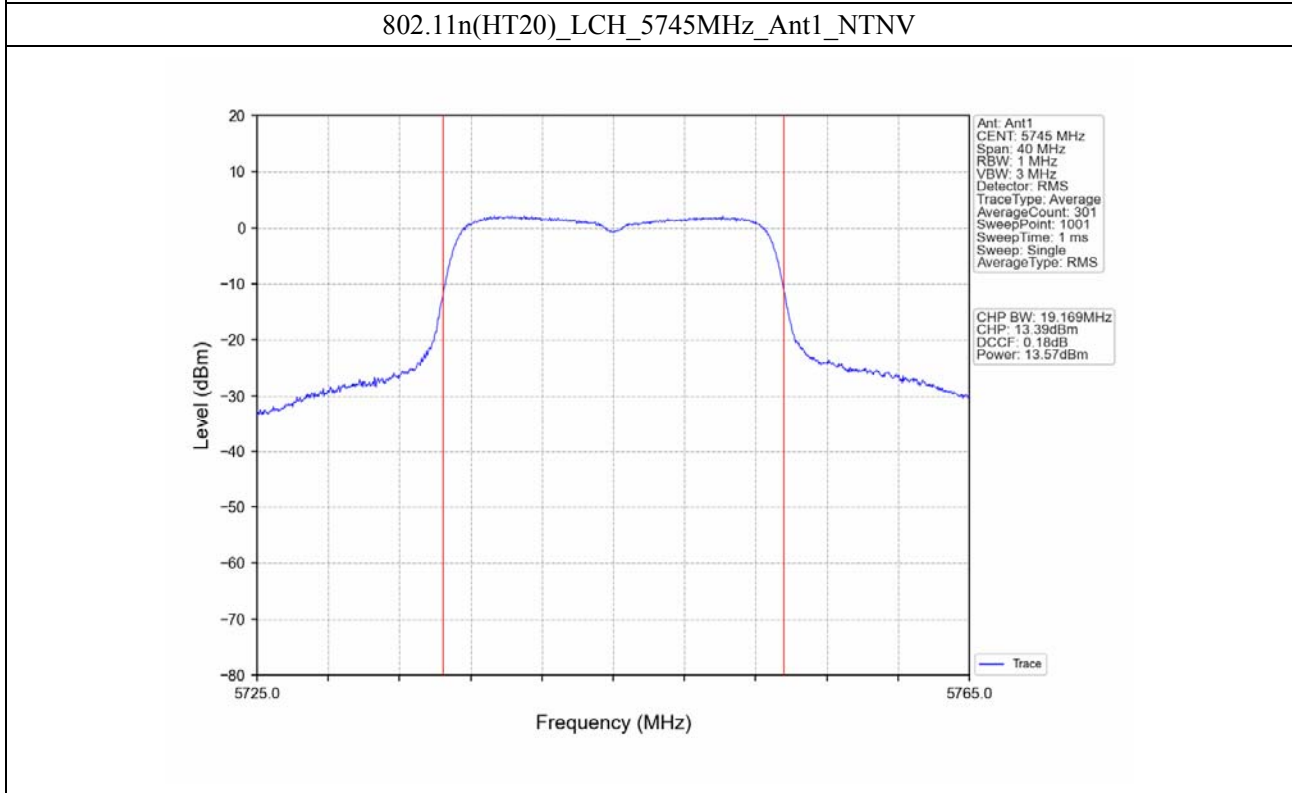

The report refers only to the sample tested and does not apply to the bulk.
This report is issued in confidence to the client and it will be strictly treated as such by the SHENZHEN TIMEWAY TESTING LABORATORIES. It may not be reproduced rather in its entirety or in part and it may not be used for advertising. The client to whom the report is issued may, however, show or send it . or a certified copy there of prepared by the SHENZHEN TIMEWAY TESTING LABORATORIES. to his customer. Supplier or others persons directly concerned. SHENZHEN TIMEWAY TESTING LABORATORIES. will not, without the consent of the client enter into any discussion of correspondence with any third party concerning the contents of the report.
In the event of the improper use of the report. The SHENZHEN TIMEWAY TESTING LABORATORIES. reserves the rights to withdraw it and to adopt any other remedies which may be appropriate.



802.11n(HT20)_MCH_5785MHz_Ant1_NTNV

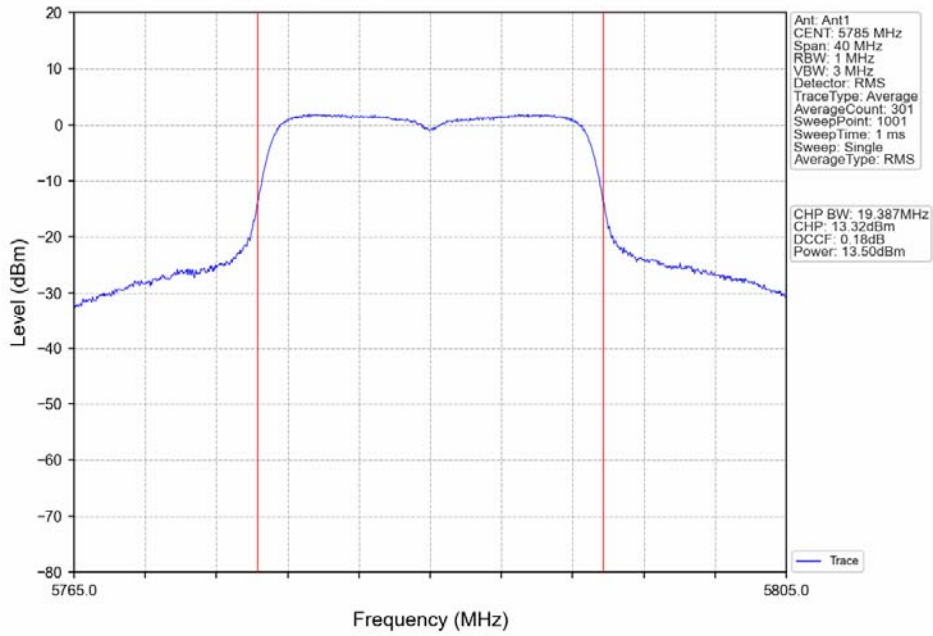

802.11n(HT20)_HCH_5825MHz_Ant1_NTNV

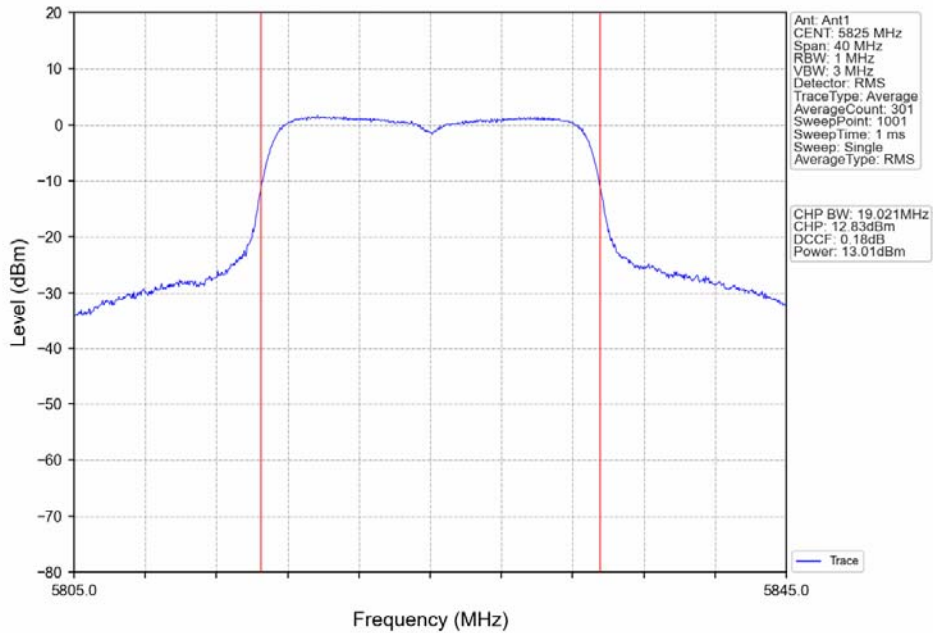

The report refers only to the sample tested and does not apply to the bulk.

This report is issued in confidence to the client and it will be strictly treated as such by the SHENZHEN TIMEWAY TESTING LABORATORIES. It may not be reproduced rather in its entirety or in part and it may not be used for advertising. The client to whom the report is issued may, however, show or send it . or a certified copy there of prepared by the SHENZHEN TIMEWAY TESTING LABORATORIES. to his customer. Supplier or others persons directly concerned. SHENZHEN TIMEWAY TESTING LABORATORIES. will not, without the consent of the client enter into any discussion of correspondence with any third party concerning the contents of the report.

In the event of the improper use of the report. The SHENZHEN TIMEWAY TESTING LABORATORIES. reserves the rights to withdraw it and to adopt any other remedies which may be appropriate.



802.11n(HT40)_LCH_5755MHz_Ant1_NTNV

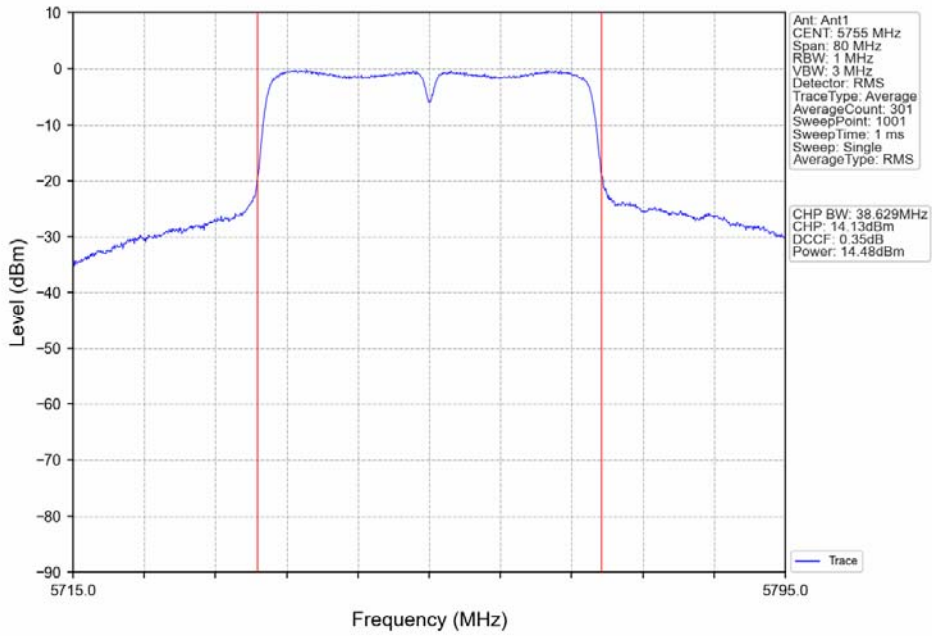

802.11n(HT40)_HCH_5795MHz_Ant1_NTNV

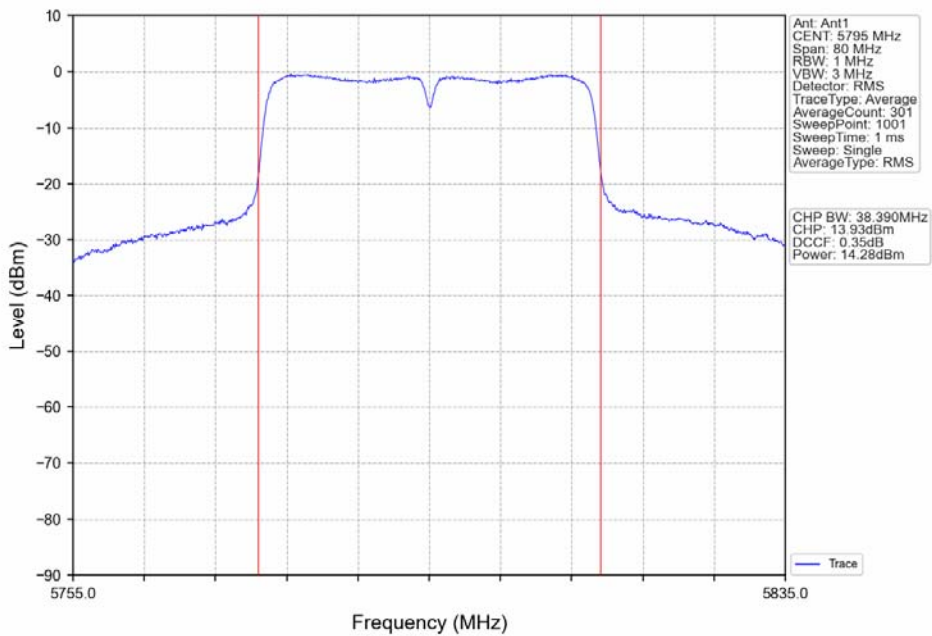

The report refers only to the sample tested and does not apply to the bulk.

This report is issued in confidence to the client and it will be strictly treated as such by the SHENZHEN TIMEWAY TESTING LABORATORIES. It may not be reproduced rather in its entirety or in part and it may not be used for advertising. The client to whom the report is issued may, however, show or send it . or a certified copy there of prepared by the SHENZHEN TIMEWAY TESTING LABORATORIES. to his customer. Supplier or others persons directly concerned. SHENZHEN TIMEWAY TESTING LABORATORIES. will not, without the consent of the client enter into any discussion of correspondence with any third party concerning the contents of the report.

In the event of the improper use of the report. The SHENZHEN TIMEWAY TESTING LABORATORIES. reserves the rights to withdraw it and to adopt any other remedies which may be appropriate.



802.11ac(VHT20)_LCH_5745MHz_Ant1_NTNV

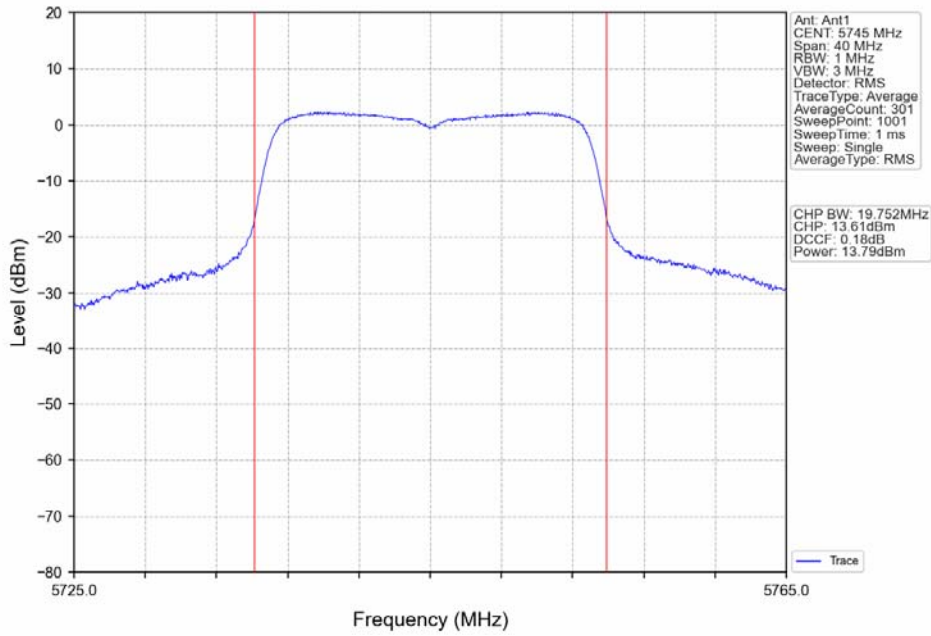

802.11ac(VHT20)_MCH_5785MHz_Ant1_NTNV

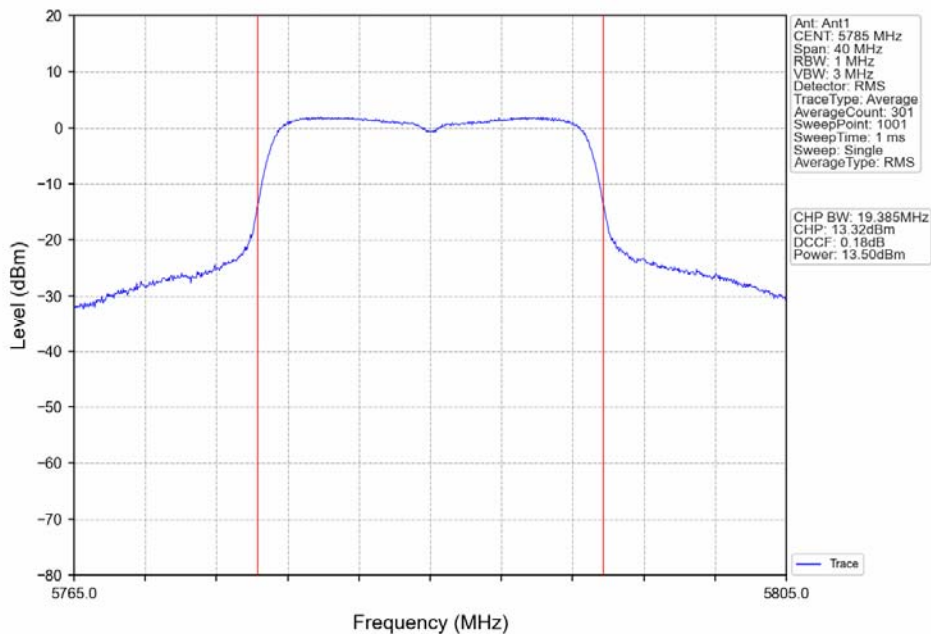

The report refers only to the sample tested and does not apply to the bulk.

This report is issued in confidence to the client and it will be strictly treated as such by the SHENZHEN TIMEWAY TESTING LABORATORIES. It may not be reproduced rather in its entirety or in part and it may not be used for advertising. The client to whom the report is issued may, however, show or send it . or a certified copy there of prepared by the SHENZHEN TIMEWAY TESTING LABORATORIES. to his customer. Supplier or others persons directly concerned. SHENZHEN TIMEWAY TESTING LABORATORIES. will not, without the consent of the client enter into any discussion of correspondence with any third party concerning the contents of the report.

In the event of the improper use of the report. The SHENZHEN TIMEWAY TESTING LABORATORIES. reserves the rights to withdraw it and to adopt any other remedies which may be appropriate.



802.11ac(VHT20)_HCH_5825MHz_Ant1_NTNV

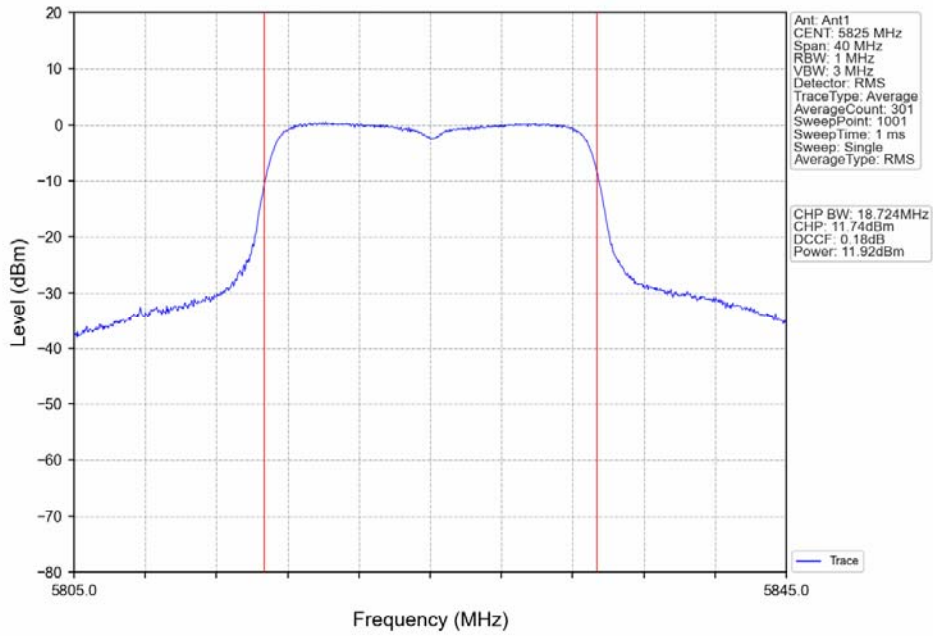

802.11ac(VHT40)_LCH_5755MHz_Ant1_NTNV

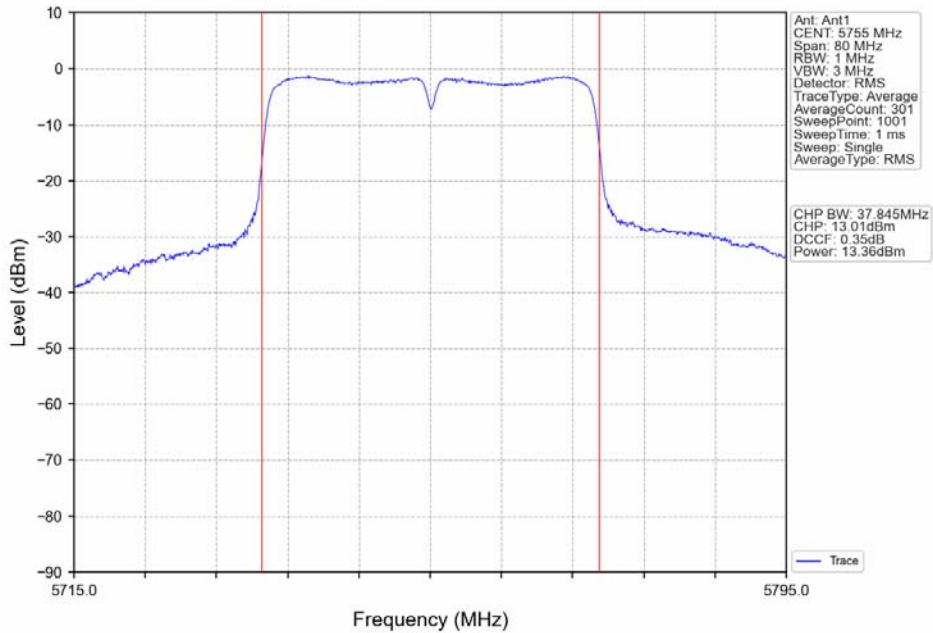

The report refers only to the sample tested and does not apply to the bulk.

This report is issued in confidence to the client and it will be strictly treated as such by the SHENZHEN TIMEWAY TESTING LABORATORIES. It may not be reproduced in its entirety or in part and it may not be used for advertising. The client to whom the report is issued may, however, show or send it, or a certified copy thereof prepared by the SHENZHEN TIMEWAY TESTING LABORATORIES, to his customer, Supplier or others persons directly concerned. SHENZHEN TIMEWAY TESTING LABORATORIES, will not, without the consent of the client enter into any discussion of correspondence with any third party concerning the contents of the report.

In the event of the improper use of the report, the SHENZHEN TIMEWAY TESTING LABORATORIES, reserves the rights to withdraw it and to adopt any other remedies which may be appropriate.



802.11ac(VHT40)_HCH_5795MHz_Ant1_NTNV

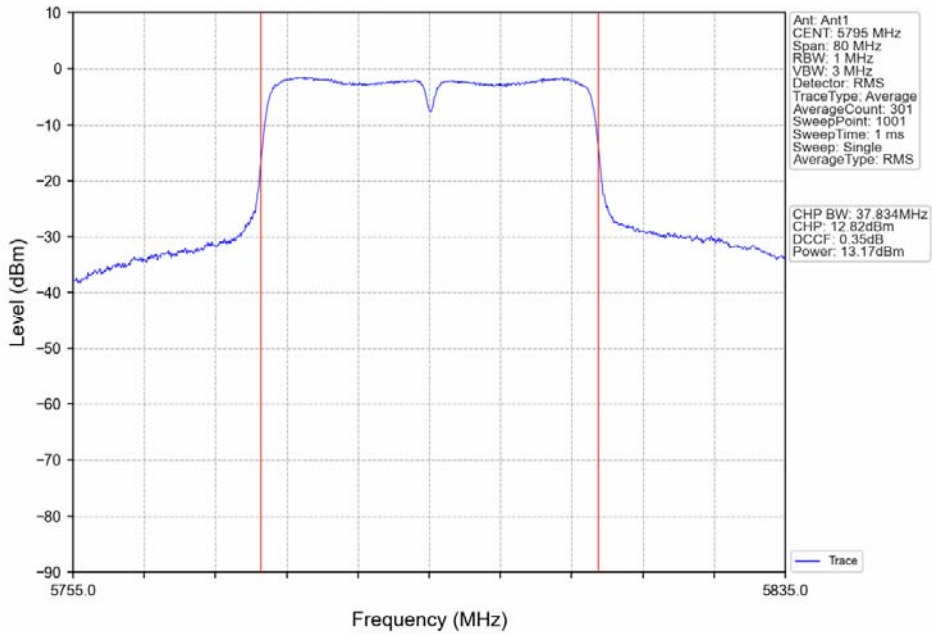

802.11ac(VHT80)_MCH_5775MHz_Ant1_NTNV

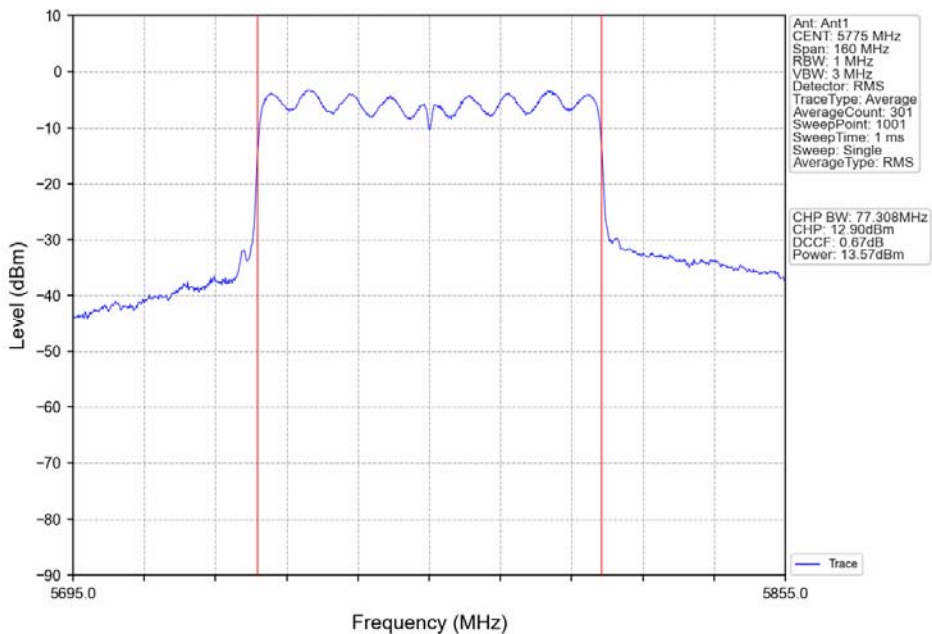

The report refers only to the sample tested and does not apply to the bulk.

This report is issued in confidence to the client and it will be strictly treated as such by the SHENZHEN TIMEWAY TESTING LABORATORIES. It may not be reproduced rather in its entirety or in part and it may not be used for advertising. The client to whom the report is issued may, however, show or send it or a certified copy thereof prepared by the SHENZHEN TIMEWAY TESTING LABORATORIES to his customer. Supplier or others persons directly concerned. SHENZHEN TIMEWAY TESTING LABORATORIES will not, without the consent of the client enter into any discussion of correspondence with any third party concerning the contents of the report.

In the event of the improper use of the report. The SHENZHEN TIMEWAY TESTING LABORATORIES reserves the rights to withdraw it and to adopt any other remedies which may be appropriate.



9. Power Spectral Density Measurement

9.1 Test Setup

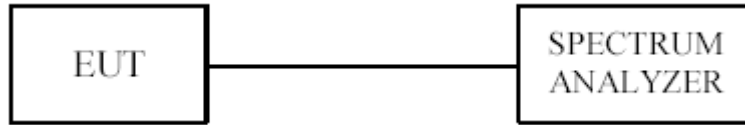

9.2 Limits of Power Spectral Density Measurement

Operation Band	EUT Category		Limit
U-NII-1		Outdoor Access Point	17dBm/MHz
		Fixed point-to-point Access Point	
		Indoor Access Point	
	√	Client device	11dBm/MHz
U-NII-2A	--		11dBm/MHz
U-NII-2C	--		11dBm/MHz
U-NII-3	--		30dBm/500kHz

9.3 Test Procedure

1. The EUT was directly connected to the spectrum analyzer
2. Set the RBW = 1MHz or 300kHz
3. Set the VBW = 3MHz or 1MHz
4. Set the span to encompass the entire emissions bandwidth (EBW) of the signal
5. Detector = RMS
6. Sweep time = auto couple.
7. Trace mode = max hold.
8. Allow trace to fully stabilize.
9. Use the peak marker function to determine the maximum amplitude level.

The report refers only to the sample tested and does not apply to the bulk.

This report is issued in confidence to the client and it will be strictly treated as such by the SHENZHEN TIMEWAY TESTING LABORATORIES. It may not be reproduced rather in its entirety or in part and it may not be used for advertising. The client to whom the report is issued may, however, show or send it, or a certified copy thereof prepared by the SHENZHEN TIMEWAY TESTING LABORATORIES, to his customer. Supplier or others persons directly concerned. SHENZHEN TIMEWAY TESTING LABORATORIES, will not, without the consent of the client enter into any discussion of correspondence with any third party concerning the contents of the report.

In the event of the improper use of the report. The SHENZHEN TIMEWAY TESTING LABORATORIES, reserves the rights to withdraw it and to adopt any other remedies which may be appropriate.



9.4 Test Result

Mode	TX Type	Frequency (MHz)	Maximum PSD (dBm/500kHz)		Verdict
			ANT1	Limit	
802.11a	SISO	5745	0.27	<=30	Pass
		5785	0.23	<=30	Pass
		5825	-0.34	<=30	Pass
802.11n (HT20)	SISO	5745	-0.66	<=30	Pass
		5785	-0.56	<=30	Pass
		5825	-1.07	<=30	Pass
802.11n (HT40)	SISO	5755	-2.74	<=30	Pass
		5795	-2.96	<=30	Pass
802.11ac (VHT20)	SISO	5745	-0.47	<=30	Pass
		5785	-0.51	<=30	Pass
		5825	-2.05	<=30	Pass
802.11ac (VHT40)	SISO	5755	-3.76	<=30	Pass
		5795	-4.08	<=30	Pass
802.11ac (VHT80)	SISO	5775	-5.90	<=30	Pass

The report refers only to the sample tested and does not apply to the bulk.
 This report is issued in confidence to the client and it will be strictly treated as such by the SHENZHEN TIMEWAY TESTING LABORATORIES. It may not be reproduced rather in its entirety or in part and it may not be used for advertising. The client to whom the report is issued may, however, show or send it or a certified copy thereof prepared by the SHENZHEN TIMEWAY TESTING LABORATORIES to his customer. Supplier or others persons directly concerned. SHENZHEN TIMEWAY TESTING LABORATORIES will not, without the consent of the client enter into any discussion of correspondence with any third party concerning the contents of the report.
 In the event of the improper use of the report. The SHENZHEN TIMEWAY TESTING LABORATORIES reserves the rights to withdraw it and to adopt any other remedies which may be appropriate.



802.11a_LCH_5745MHz_Ant1_NTNV

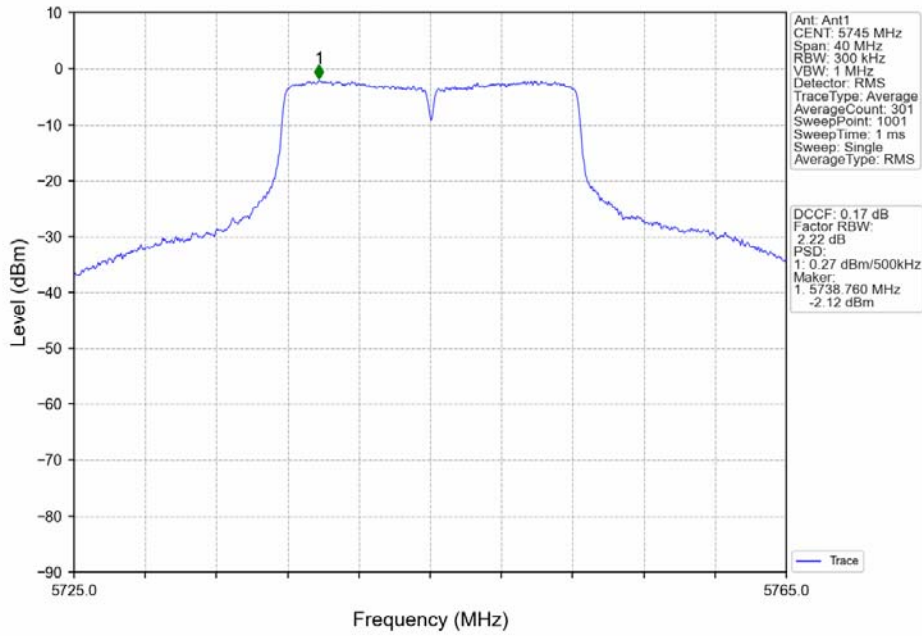

802.11a_MCH_5785MHz_Ant1_NTNV

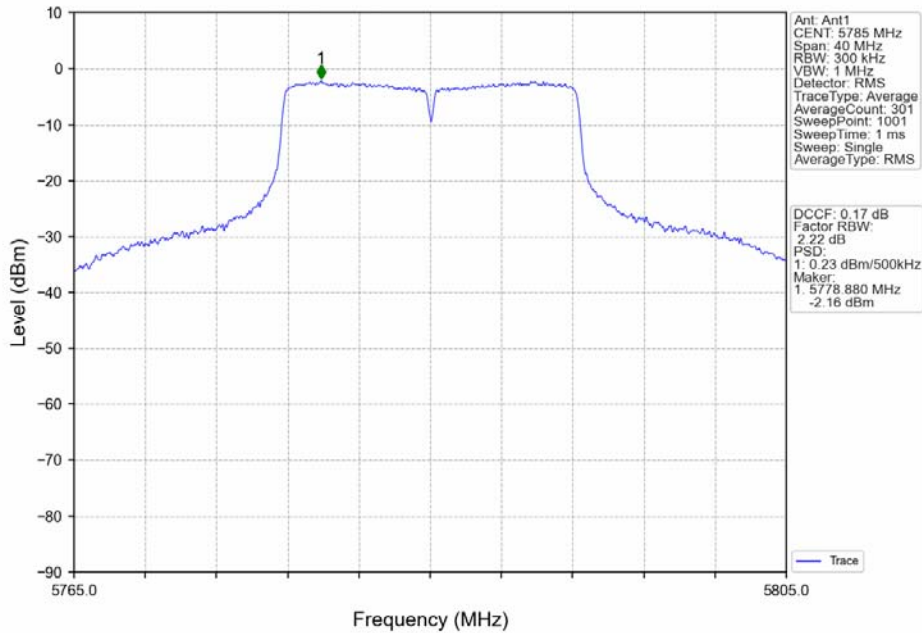

The report refers only to the sample tested and does not apply to the bulk.

This report is issued in confidence to the client and it will be strictly treated as such by the SHENZHEN TIMEWAY TESTING LABORATORIES. It may not be reproduced rather in its entirety or in part and it may not be used for advertising. The client to whom the report is issued may, however, show or send it . or a certified copy there of prepared by the SHENZHEN TIMEWAY TESTING LABORATORIES. to his customer. Supplier or others persons directly concerned. SHENZHEN TIMEWAY TESTING LABORATORIES. will not, without the consent of the client enter into any discussion of correspondence with any third party concerning the contents of the report.

In the event of the improper use of the report. The SHENZHEN TIMEWAY TESTING LABORATORIES. reserves the rights to withdraw it and to adopt any other remedies which may be appropriate.

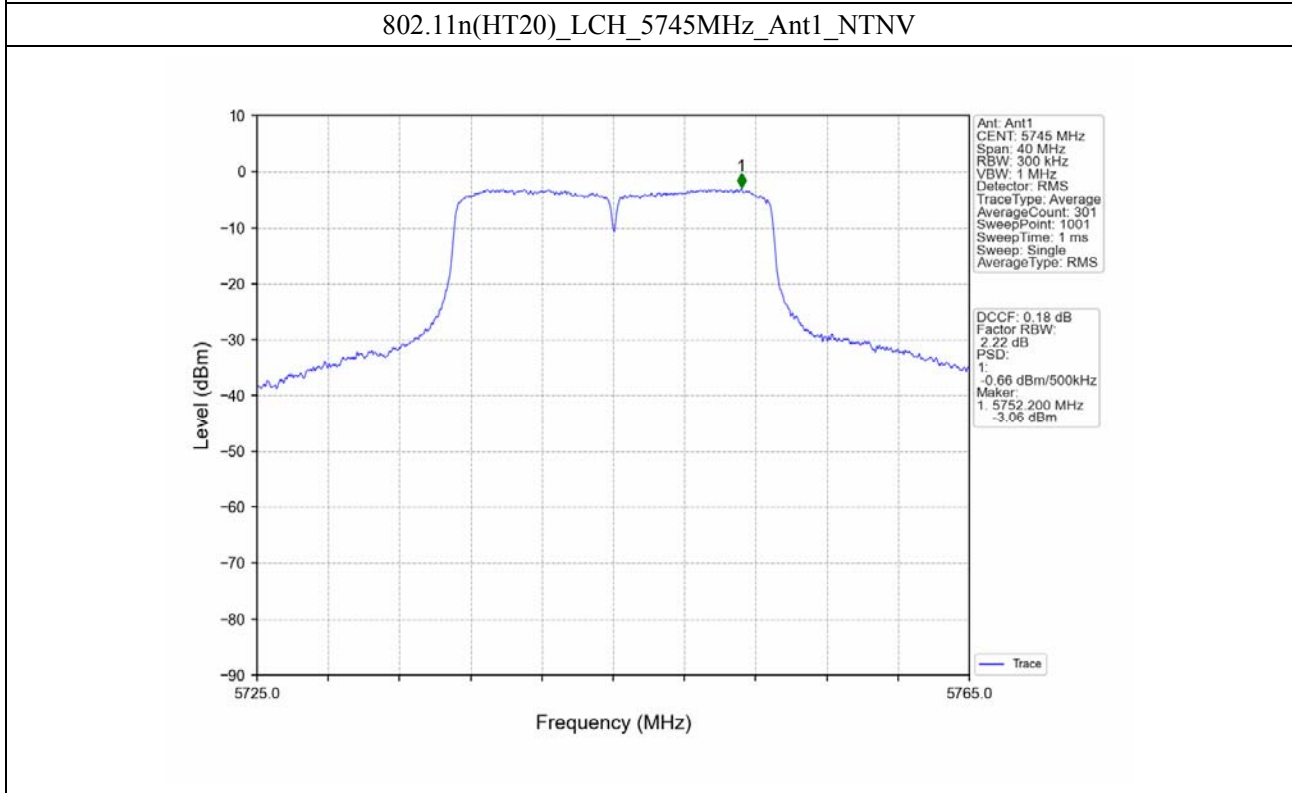
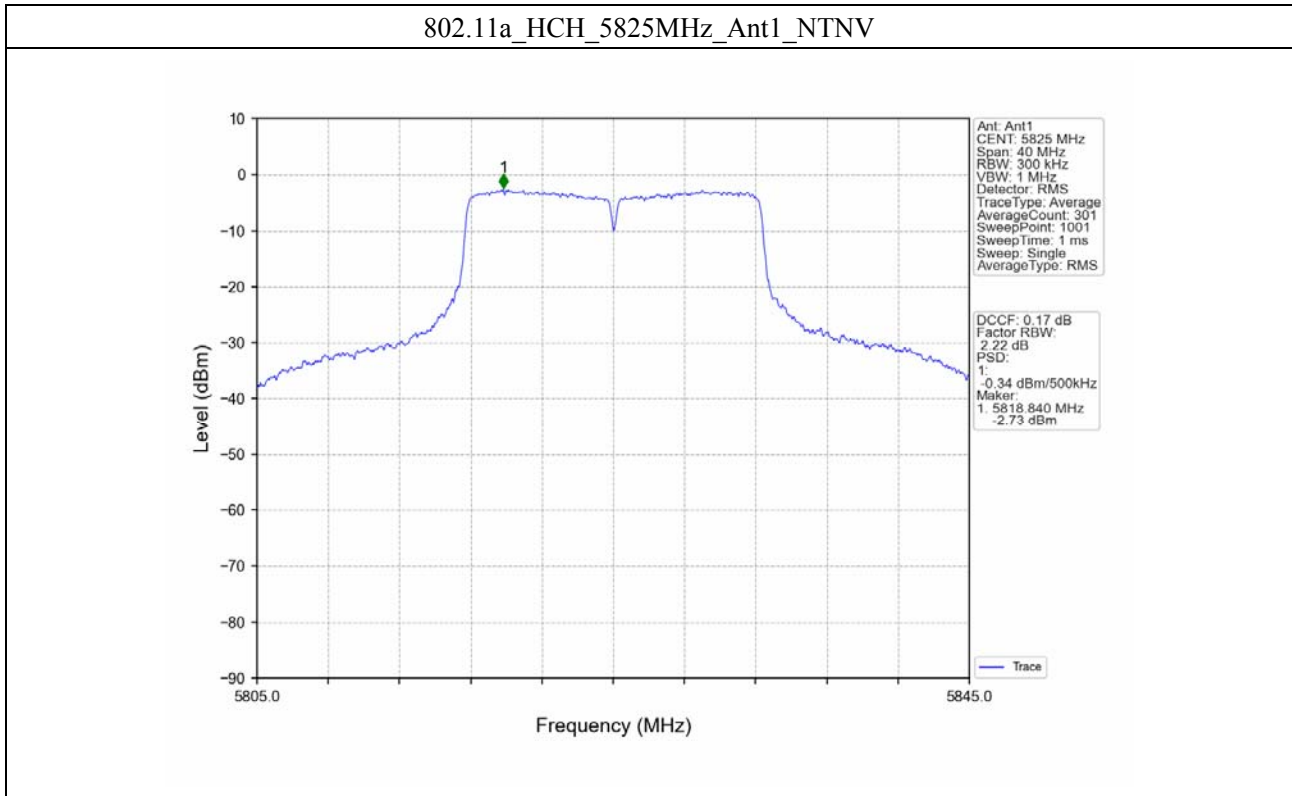

The report refers only to the sample tested and does not apply to the bulk.
This report is issued in confidence to the client and it will be strictly treated as such by the SHENZHEN TIMEWAY TESTING LABORATORIES. It may not be reproduced rather in its entirety or in part and it may not be used for advertising. The client to whom the report is issued may, however, show or send it . or a certified copy there of prepared by the SHENZHEN TIMEWAY TESTING LABORATORIES. to his customer. Supplier or others persons directly concerned. SHENZHEN TIMEWAY TESTING LABORATORIES. will not, without the consent of the client enter into any discussion of correspondence with any third party concerning the contents of the report.
In the event of the improper use of the report. The SHENZHEN TIMEWAY TESTING LABORATORIES. reserves the rights to withdraw it and to adopt any other remedies which may be appropriate.



802.11n(HT20)_MCH_5785MHz_Ant1_NTNV

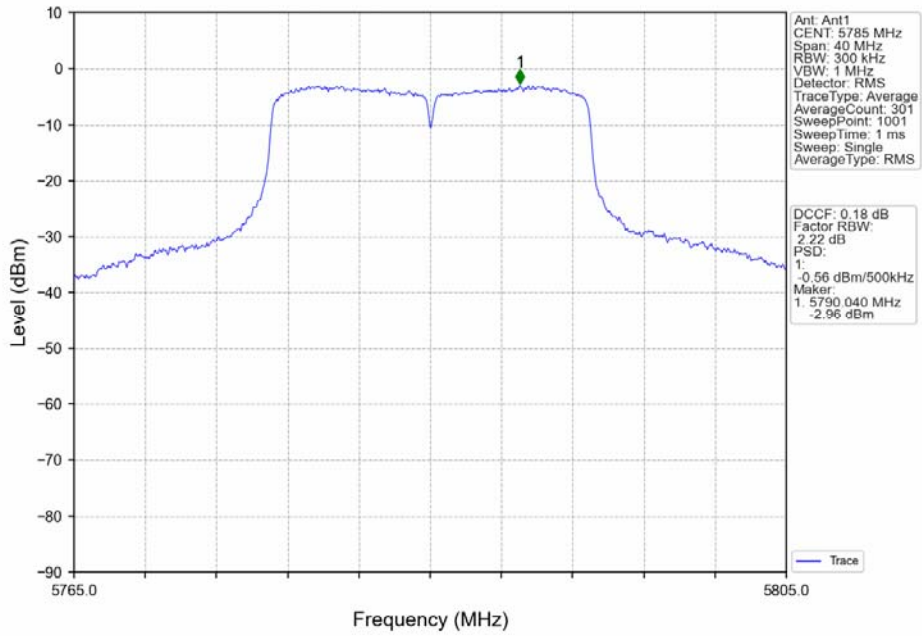

802.11n(HT20)_HCH_5825MHz_Ant1_NTNV

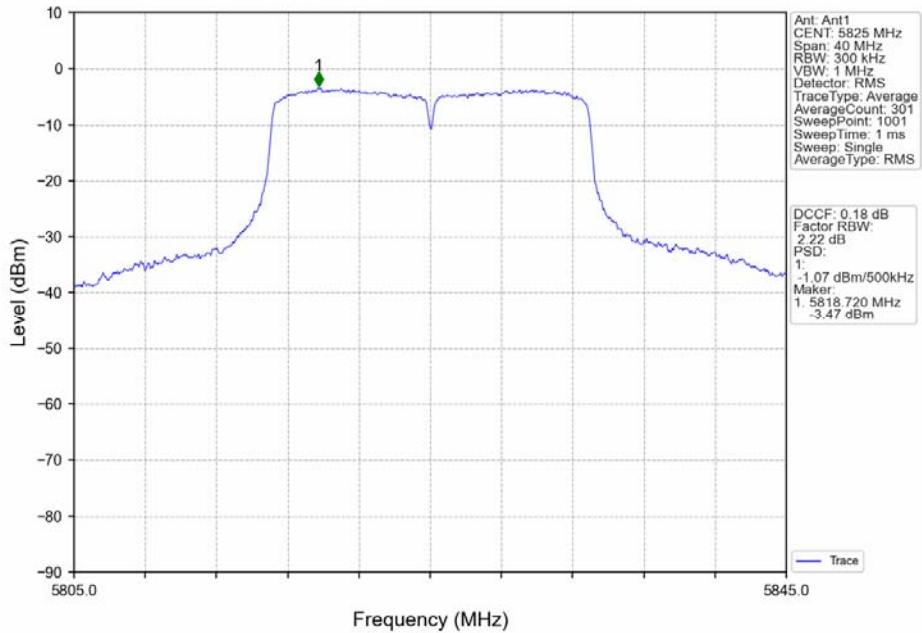

The report refers only to the sample tested and does not apply to the bulk.

This report is issued in confidence to the client and it will be strictly treated as such by the SHENZHEN TIMEWAY TESTING LABORATORIES. It may not be reproduced rather in its entirety or in part and it may not be used for advertising. The client to whom the report is issued may, however, show or send it . or a certified copy there of prepared by the SHENZHEN TIMEWAY TESTING LABORATORIES. to his customer. Supplier or others persons directly concerned. SHENZHEN TIMEWAY TESTING LABORATORIES. will not, without the consent of the client enter into any discussion of correspondence with any third party concerning the contents of the report.

In the event of the improper use of the report. The SHENZHEN TIMEWAY TESTING LABORATORIES. reserves the rights to withdraw it and to adopt any other remedies which may be appropriate.



802.11n(HT40)_LCH_5755MHz_Ant1_NTNV

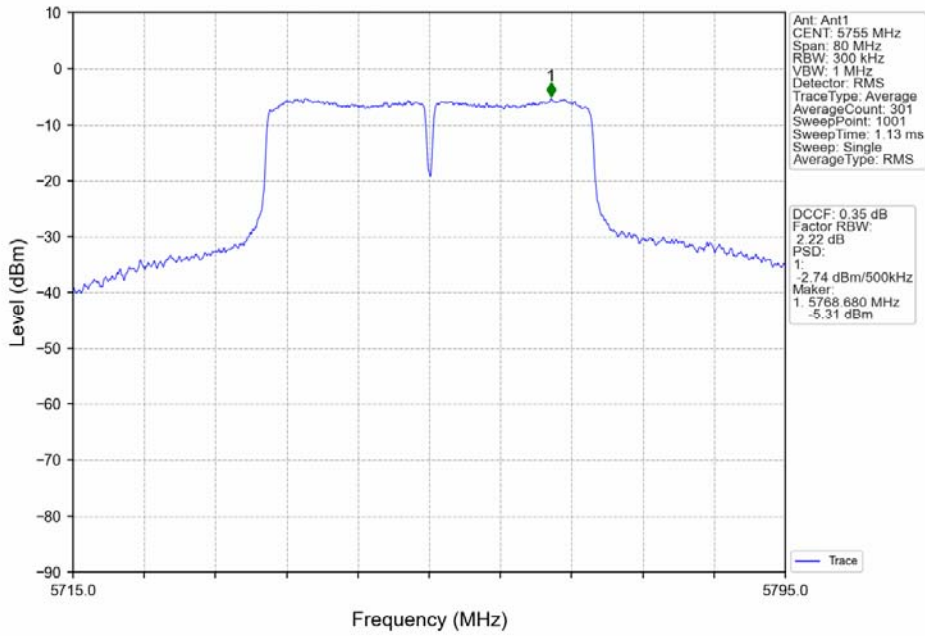

802.11n(HT40)_HCH_5795MHz_Ant1_NTNV

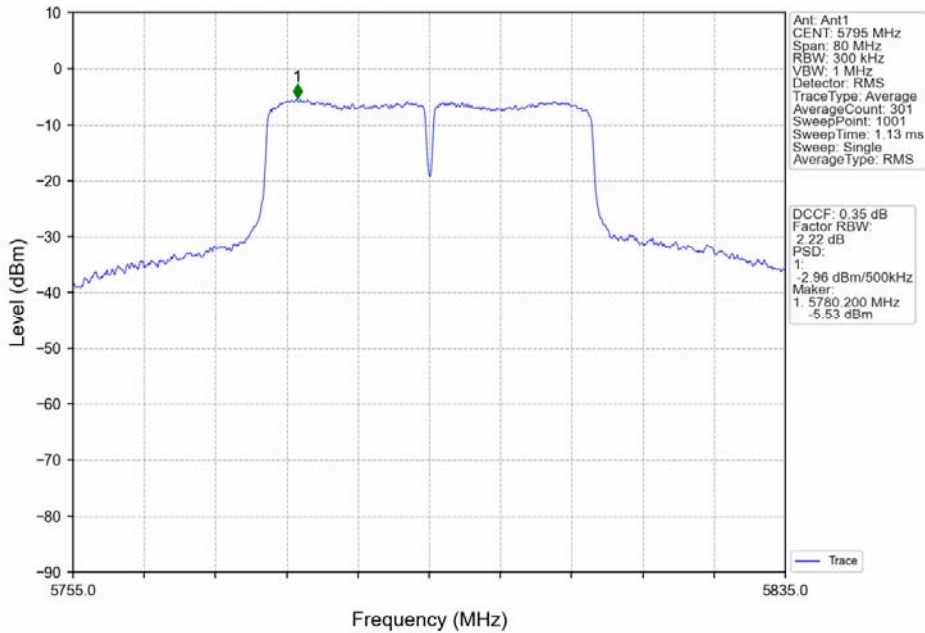

The report refers only to the sample tested and does not apply to the bulk.

This report is issued in confidence to the client and it will be strictly treated as such by the SHENZHEN TIMEWAY TESTING LABORATORIES. It may not be reproduced rather in its entirety or in part and it may not be used for advertising. The client to whom the report is issued may, however, show or send it . or a certified copy there of prepared by the SHENZHEN TIMEWAY TESTING LABORATORIES. to his customer. Supplier or others persons directly concerned. SHENZHEN TIMEWAY TESTING LABORATORIES. will not, without the consent of the client enter into any discussion of correspondence with any third party concerning the contents of the report.

In the event of the improper use of the report. The SHENZHEN TIMEWAY TESTING LABORATORIES. reserves the rights to withdraw it and to adopt any other remedies which may be appropriate.



802.11ac(VHT20)_LCH_5745MHz_Ant1_NTNV

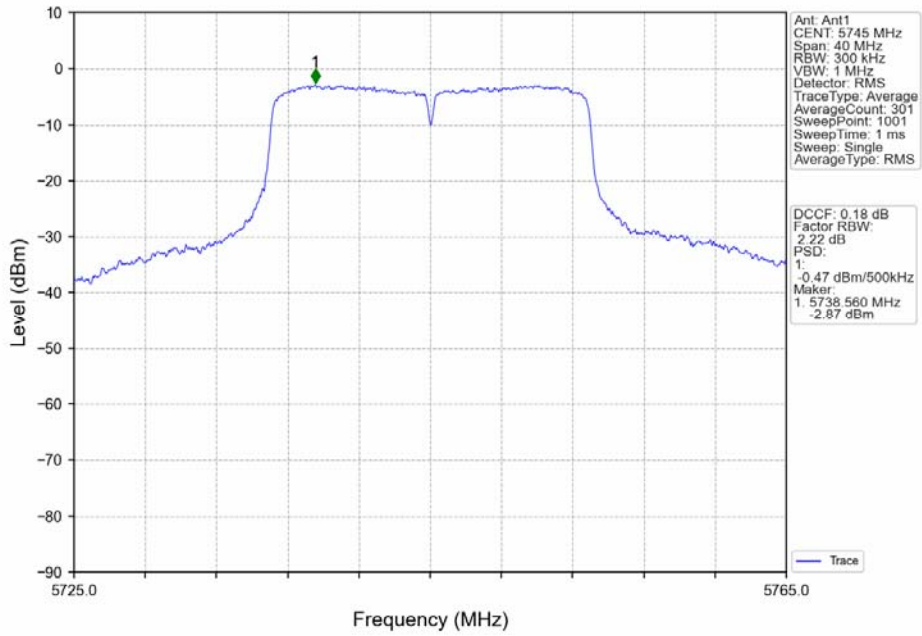

802.11ac(VHT20)_MCH_5785MHz_Ant1_NTNV

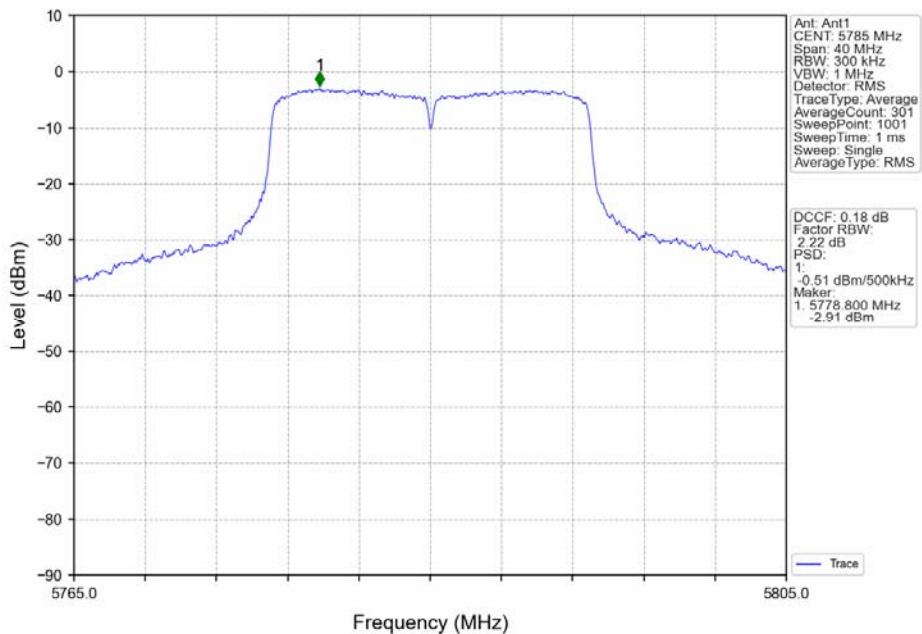

The report refers only to the sample tested and does not apply to the bulk.

This report is issued in confidence to the client and it will be strictly treated as such by the SHENZHEN TIMEWAY TESTING LABORATORIES. It may not be reproduced rather in its entirety or in part and it may not be used for advertising. The client to whom the report is issued may, however, show or send it . or a certified copy there of prepared by the SHENZHEN TIMEWAY TESTING LABORATORIES. to his customer. Supplier or others persons directly concerned. SHENZHEN TIMEWAY TESTING LABORATORIES. will not, without the consent of the client enter into any discussion of correspondence with any third party concerning the contents of the report.

In the event of the improper use of the report. The SHENZHEN TIMEWAY TESTING LABORATORIES. reserves the rights to withdraw it and to adopt any other remedies which may be appropriate.



802.11ac(VHT20)_HCH_5825MHz_Ant1_NTNV

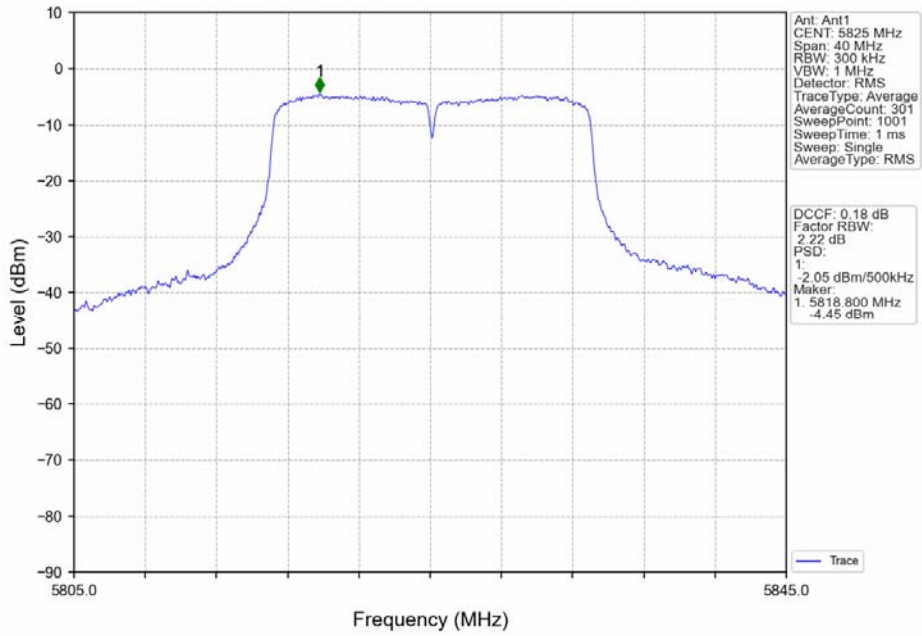

802.11ac(VHT40)_LCH_5755MHz_Ant1_NTNV

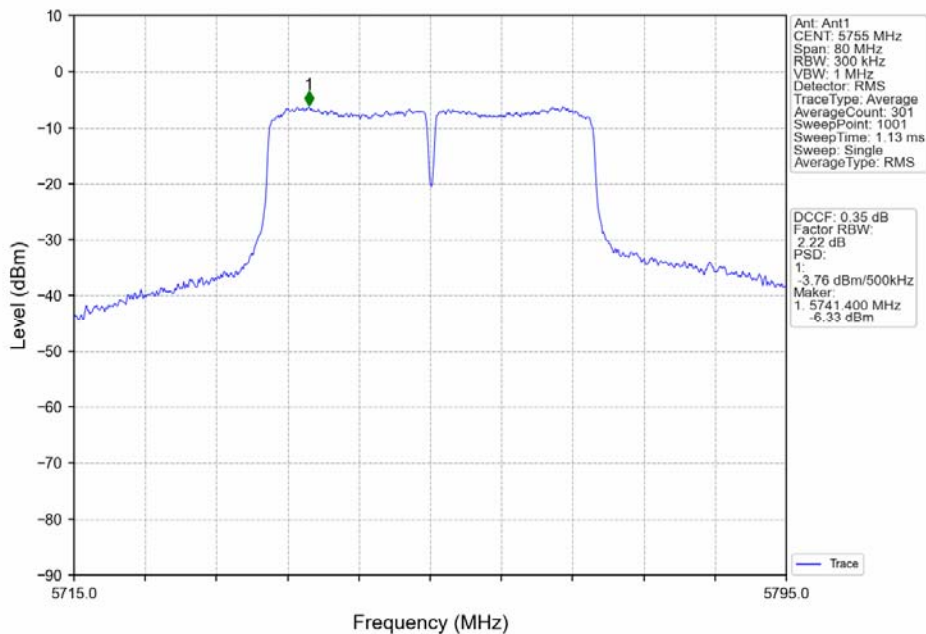

The report refers only to the sample tested and does not apply to the bulk.

This report is issued in confidence to the client and it will be strictly treated as such by the SHENZHEN TIMEWAY TESTING LABORATORIES. It may not be reproduced rather in its entirety or in part and it may not be used for advertising. The client to whom the report is issued may, however, show or send it . or a certified copy there of prepared by the SHENZHEN TIMEWAY TESTING LABORATORIES. to his customer. Supplier or others persons directly concerned. SHENZHEN TIMEWAY TESTING LABORATORIES. will not, without the consent of the client enter into any discussion of correspondence with any third party concerning the contents of the report.

In the event of the improper use of the report. The SHENZHEN TIMEWAY TESTING LABORATORIES. reserves the rights to withdraw it and to adopt any other remedies which may be appropriate.



802.11ac(VHT40)_HCH_5795MHz_Ant1_NTNV

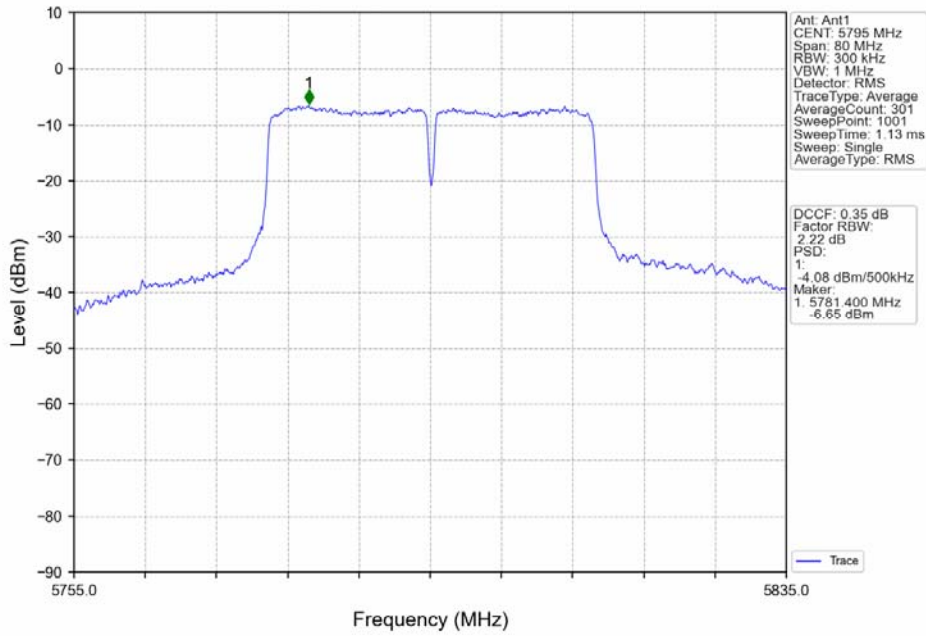

802.11ac(VHT80)_MCH_5775MHz_Ant1_NTNV

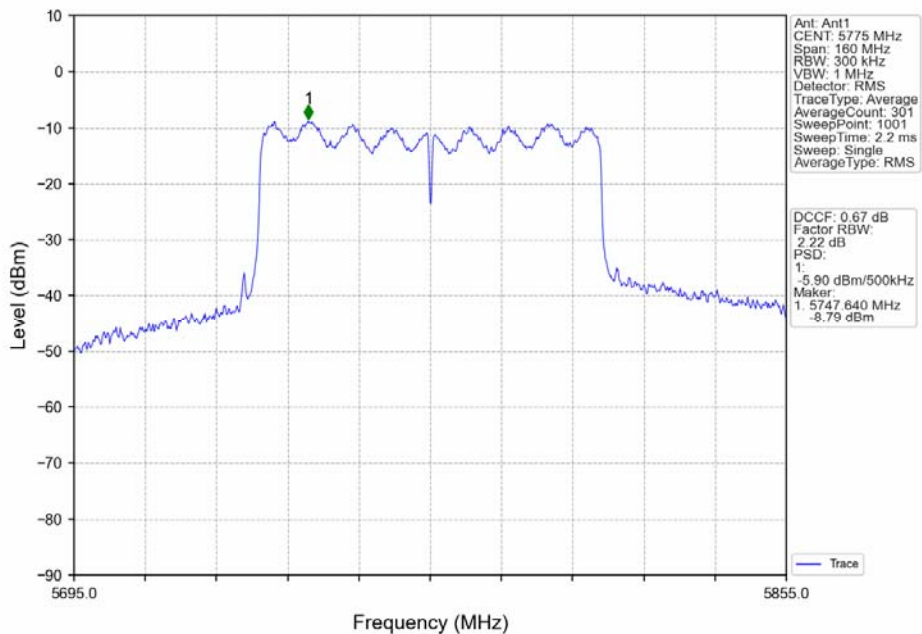

The report refers only to the sample tested and does not apply to the bulk.

This report is issued in confidence to the client and it will be strictly treated as such by the SHENZHEN TIMEWAY TESTING LABORATORIES. It may not be reproduced rather in its entirety or in part and it may not be used for advertising. The client to whom the report is issued may, however, show or send it . or a certified copy there of prepared by the SHENZHEN TIMEWAY TESTING LABORATORIES. to his customer. Supplier or others persons directly concerned. SHENZHEN TIMEWAY TESTING LABORATORIES. will not, without the consent of the client enter into any discussion of correspondence with any third party concerning the contents of the report.

In the event of the improper use of the report. The SHENZHEN TIMEWAY TESTING LABORATORIES. reserves the rights to withdraw it and to adopt any other remedies which may be appropriate.



10.0 Frequency Stability

10.1 Limits of Frequency Stability Measurement

The frequency tolerance of the carrier signal shall be maintained within +/- 0.02% of the operating frequency over a temperature variation of -30 degrees to 50 degrees C at normal supply voltage, and for a variation in the primary supply voltage from 85% to 115% of the rated supply voltage at a temperature of 20 degrees

10.2 Test Procedure

1. The EUT was placed inside the environmental test chamber and powered by nominal DC voltage.
2. Turn the EUT on and couple its output to a spectrum analyzer.
3. Turn the EUT off and set the chamber to the highest temperature specified.
4. Allow sufficient time (approximately 30 min) for the temperature of the chamber to stabilize, turn the EUT on and measure the operating frequency after 2, 5, and 10 minutes.
5. Repeat step 2 and 3 with the temperature chamber set to the lowest temperature.
6. The test chamber was allowed to stabilize at +20 degree C for a minimum of 30 minutes. The supply voltage was then adjusted on the EUT from 85% to 115% and the frequency record.

The report refers only to the sample tested and does not apply to the bulk.

This report is issued in confidence to the client and it will be strictly treated as such by the SHENZHEN TIMEWAY TESTING LABORATORIES. It may not be reproduced rather in its entirety or in part and it may not be used for advertising. The client to whom the report is issued may, however, show or send it or a certified copy thereof prepared by the SHENZHEN TIMEWAY TESTING LABORATORIES to his customer. Supplier or others persons directly concerned. SHENZHEN TIMEWAY TESTING LABORATORIES will not, without the consent of the client enter into any discussion of correspondence with any third party concerning the contents of the report.

In the event of the improper use of the report. The SHENZHEN TIMEWAY TESTING LABORATORIES reserves the rights to withdraw it and to adopt any other remedies which may be appropriate.



10.3 Test Result

Channel 149 (5745MHz)

Voltage vs. Frequency Stability

Voltage	Measurement Frequency (MHz)
5.0V	5745.0530
4.25V	5745.0529
5.75V	5745.0521
Max. Deviation (MHz)	0.0530
Max. Deviation (ppm)	9.23

Rated working voltage: DC5.0V

Temperature vs. Frequency Stability

Temperature (°C)	Measurement Frequency (MHz)
-30	5745.0536
-20	5745.0541
-10	5745.0528
0	5745.0537
10	5745.0543
20	5745.0526
30	5745.0520
40	5745.0535
50	5745.0537
Max. Deviation (MHz)	0.0543
Max. Deviation (ppm)	9.45

The report refers only to the sample tested and does not apply to the bulk.

This report is issued in confidence to the client and it will be strictly treated as such by the SHENZHEN TIMEWAY TESTING LABORATORIES. It may not be reproduced rather in its entirety or in part and it may not be used for advertising. The client to whom the report is issued may, however, show or send it or a certified copy thereof prepared by the SHENZHEN TIMEWAY TESTING LABORATORIES to his customer. Supplier or others persons directly concerned. SHENZHEN TIMEWAY TESTING LABORATORIES will not, without the consent of the client enter into any discussion of correspondence with any third party concerning the contents of the report.

In the event of the improper use of the report. The SHENZHEN TIMEWAY TESTING LABORATORIES reserves the rights to withdraw it and to adopt any other remedies which may be appropriate.



11.0 Antenna Requirement

11.1 Standard Applicable

For intentional device, according to FCC 47 CFR Section 15.203, an intentional radiator shall be designed to ensure that no antenna other than that furnished by the responsible party shall be used with the device.

And according to FCC 47 CFR Section 15.247 (b), if transmitter antennas of directional gain greater than 6 dBi are used, the power shall be reduced by the amount in dB that the directional gain of the antenna exceeds 6 dBi.

11.2 Antenna Connected construction

Integral antenna with gain -0.8dBi for Band 4 (Get from the antenna specification)

The report refers only to the sample tested and does not apply to the bulk.

This report is issued in confidence to the client and it will be strictly treated as such by the SHENZHEN TIMEWAY TESTING LABORATORIES. It may not be reproduced either in its entirety or in part and it may not be used for advertising. The client to whom the report is issued may, however, show or send it or a certified copy thereof prepared by the SHENZHEN TIMEWAY TESTING LABORATORIES to his customer. Supplier or other persons directly concerned. SHENZHEN TIMEWAY TESTING LABORATORIES will not, without the consent of the client enter into any discussion of correspondence with any third party concerning the contents of the report.

In the event of the improper use of the report. The SHENZHEN TIMEWAY TESTING LABORATORIES reserves the rights to withdraw it and to adopt any other remedies which may be appropriate.



12.0 FCC Label

FCC ID: 2BA5E-WD4512BT

The label must not be a stick-on paper label. The label on these products must be permanently affixed to the product and readily visible at the time of purchase and must last the expected lifetime of the equipment not be readily detachable.

Mark Location:

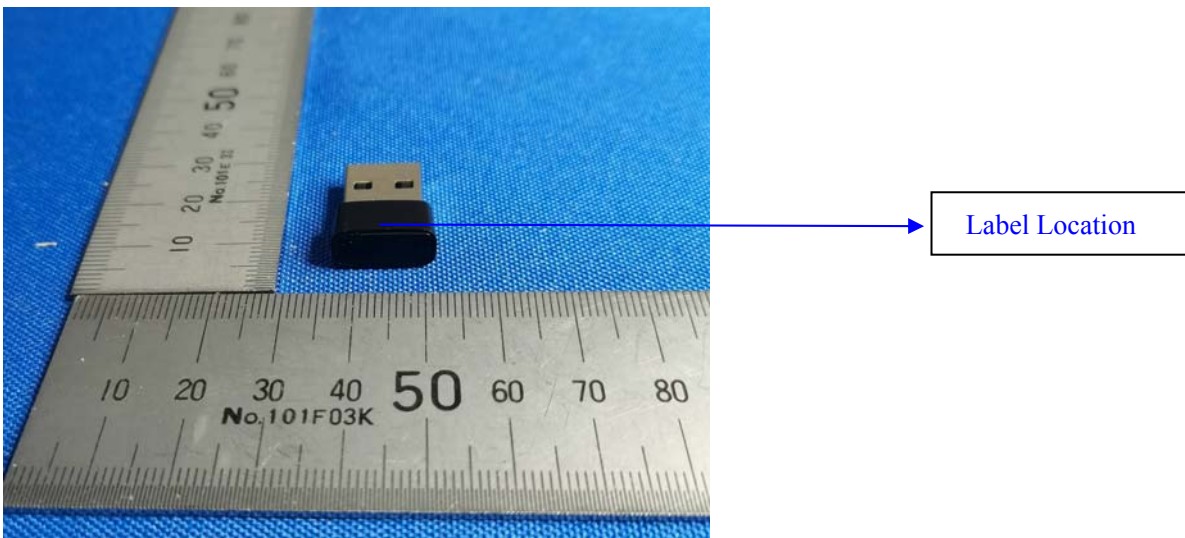

The report refers only to the sample tested and does not apply to the bulk.

This report is issued in confidence to the client and it will be strictly treated as such by the SHENZHEN TIMEWAY TESTING LABORATORIES. It may not be reproduced rather in its entirety or in part and it may not be used for advertising. The client to whom the report is issued may, however, show or send it or a certified copy thereof prepared by the SHENZHEN TIMEWAY TESTING LABORATORIES to his customer. Supplier or others persons directly concerned. SHENZHEN TIMEWAY TESTING LABORATORIES will not, without the consent of the client enter into any discussion of correspondence with any third party concerning the contents of the report.

In the event of the improper use of the report. The SHENZHEN TIMEWAY TESTING LABORATORIES reserves the rights to withdraw it and to adopt any other remedies which may be appropriate.



13.0 Photo of testing

Conducted Emission Test Setup:



The report refers only to the sample tested and does not apply to the bulk.

This report is issued in confidence to the client and it will be strictly treated as such by the SHENZHEN TIMEWAY TESTING LABORATORIES. It may not be reproduced rather in its entirety or in part and it may not be used for advertising. The client to whom the report is issued may, however, show or send it or a certified copy thereof prepared by the SHENZHEN TIMEWAY TESTING LABORATORIES to his customer. Supplier or others persons directly concerned. SHENZHEN TIMEWAY TESTING LABORATORIES will not, without the consent of the client enter into any discussion of correspondence with any third party concerning the contents of the report.

In the event of the improper use of the report. The SHENZHEN TIMEWAY TESTING LABORATORIES reserves the rights to withdraw it and to adopt any other remedies which may be appropriate.



Radiated Emission Test Setup:

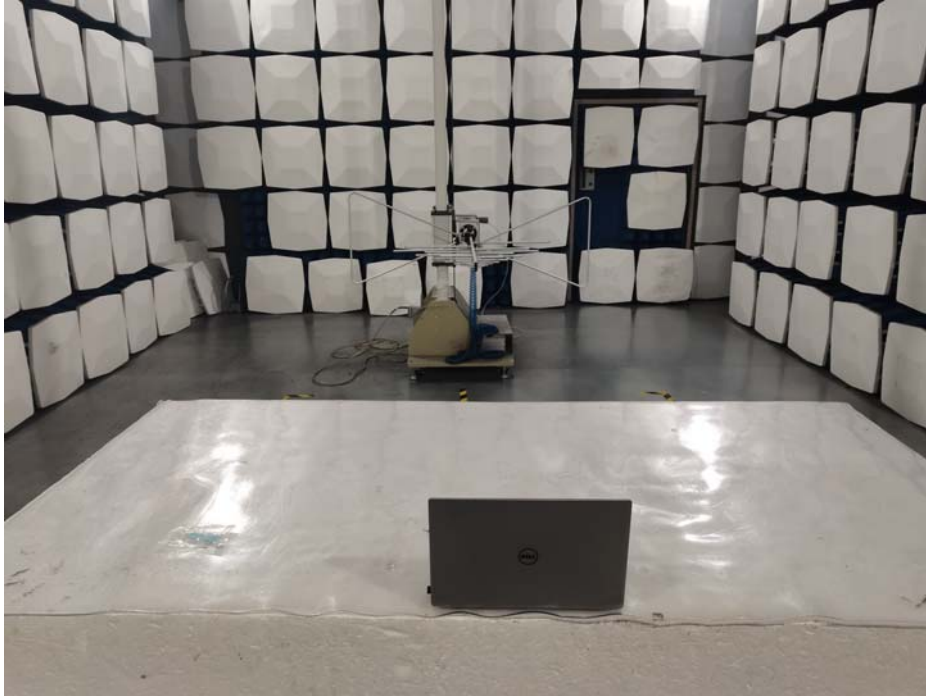

Photos of EUT

Please see test report TW2305186-01E

--End of the report--

The report refers only to the sample tested and does not apply to the bulk.

This report is issued in confidence to the client and it will be strictly treated as such by the SHENZHEN TIMEWAY TESTING LABORATORIES. It may not be reproduced rather in its entirety or in part and it may not be used for advertising. The client to whom the report is issued may, however, show or send it or a certified copy thereof prepared by the SHENZHEN TIMEWAY TESTING LABORATORIES to his customer. Supplier or others persons directly concerned. SHENZHEN TIMEWAY TESTING LABORATORIES will not, without the consent of the client enter into any discussion of correspondence with any third party concerning the contents of the report.

In the event of the improper use of the report. The SHENZHEN TIMEWAY TESTING LABORATORIES reserves the rights to withdraw it and to adopt any other remedies which may be appropriate.