



3D Printer User Manual

V1.0

To Our Dear Users

Thank you for choosing Creality. For your convenience, please read through this User Manual before you start and follow the instructions provided carefully.

Creality is always ready to provide you with high-quality services. If you encounter any issues or have any questions when using our products, please use the contact information at the end of this manual to contact us. To further improve your user experience, you can find more about our devices via the following methods:

User manual: You can find instructions and videos in the USB flash disk provided with the printer.

You can also visit our official website (<https://www.creality.com>) to find information regarding software, hardware, contact information, device instructions, device warranty information, and more.

Firmware Upgrade

1. You can upgrade the firmware directly through the device screen;
2. You can upgrade the firmware via the Creality Cloud OTA;
3. Please visit the official website <https://www.creality.com>, click on Service Center → Firmware/Software Download → Download the required firmware, install and use it.

Videos showing the operation of the products and after-sales service

1. Please visit <https://www.crealitycloud.com/product>, click “Products” and select the right model, and then click “Related” to view the tutorials on after-sales service;
 2. Or contact our after-sales service center at +86 755 3396 5666, or send e-mail to cs@creality.com.
-

NOTES

1. Do not use the printer in any way other than described herein in order to avoid personal injury or property damage;
2. Do not place the printer near any heat source or flammable or explosive objects. We suggest placing it in a well-ventilated, cool and dustless environment;
3. Do not expose the printer to a violent vibration or any other unstable environment, as this may cause poor print quality;
4. Please use recommended filaments to avoid clogging of the extrusion head and causing damage to the machine;
5. Do not use the power cable of other products during installation. Always use a grounded three-prong power outlet, which accompanies the printer;
6. Do not touch the nozzle and the heated bed during operation to avoid burns or personal injury;
7. Do not wear gloves or wraps while operating the machine to prevent entrapment of movable parts that could cause crushing and cutting injuries to bodily parts;
8. Use the provided tools to clean the filament from the extruder in time taking advantage of the residual temperature after printing. Do not touch the extruder directly when cleaning, otherwise it may cause burns;
9. Clean the printer frequently. Clean the printer body with a dry cloth regularly after powering off the printer, wipe away dust, bonded print filament and foreign objects on the guide rails;
10. Children under 10 years old should not use the printer without supervision, otherwise it may cause personal injury;
11. Users should comply with the laws and regulations of the corresponding countries and regions where the equipment is located (used), abide by professional ethics, pay attention to safety obligations, and strictly prohibit the use of our products or equipment for any illegal purposes; Creality will not be responsible for any violators' legal liability under any circumstance;
12. Tip: Do not plug in or unplug wires on a charged basis.

Contents



1. About the Printer	01-01
2. Parts List	02-02
3. Assembly Procedure	03-06
3.1 Material Rack Assembly Installation	03-03
3.2 Gantry Frame Assembly Installation	04-04
3.3 Pull rod installation	05-05
3.4 Touch screen Installation	06-16
3.5 Equipment Wiring	07-07
4. About the Power-on Guide and User Interface	08-12
4.1 Power-on guide	08-09
4.2 About the User Interface	10-12
5. First Printing	13-17
5.1 Filament Loading	13-13
5.2 LAN Printing	14-16
5.3 USB flash disk Printing	17-17
6. Functional Specification	18-20
6.1 Filament Retreat	18-19
6.2 Auto extrude	20-20
7. Equipment Maintenance	21-21
7.1 Platform plate removal and maintenance	21-21
7.2 Optical axis maintenance	21-21
8. Equipment Parameters	22-22
9. Circuit Wiring	23-23

1.About the Printer

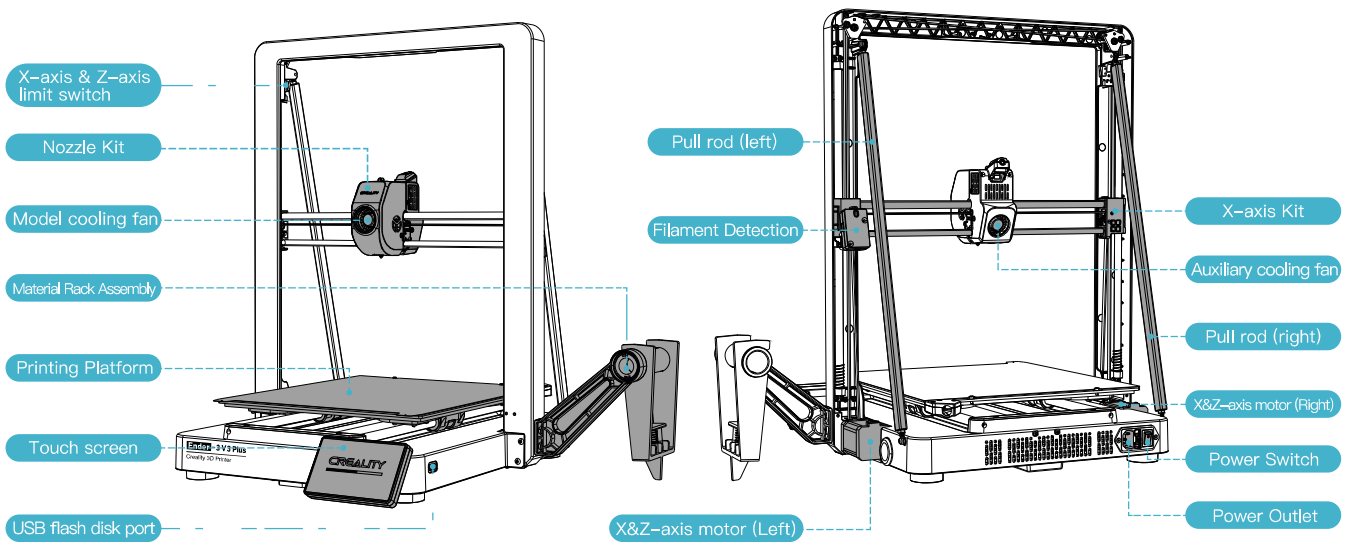

2.Parts List

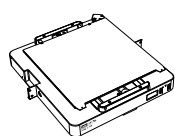

1 Base component

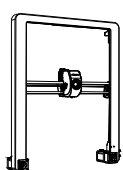

2 Gantry Frame Assembly



3 Touch screen

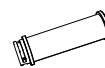

4 Filament tube



5 Material Rack

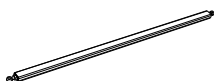

6 Pull rod x2



7 Power cable

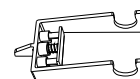

8 Anti-tangle material rack

Accessory kit



9 Hexagon Flat Round Head Screw M4*8 x8



13 Teflon tube



17 Wire Clip x3



21 Quick Installation Guide



10 Hexagon Flat Round Head Screw M4x10 x4



14 Filament

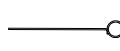

18 Nozzle cleaner



22 After-sales Services Card



11 Tool kit



15 Cutting plier



19 Extruder cable cover



12 Socket spanner



16 Black tie x5



20 USB flash disk

注意：以上配件仅供参考，请以实物为准。

3.Assembly Procedure

3.1 Material Rack Assembly Installation

- ① Install the material rack and material barrel according to the diagram;
- ② Align the installed material rack component holes with the locking positions to the immediate right of the gantry frame and secure them downwards smoothly.

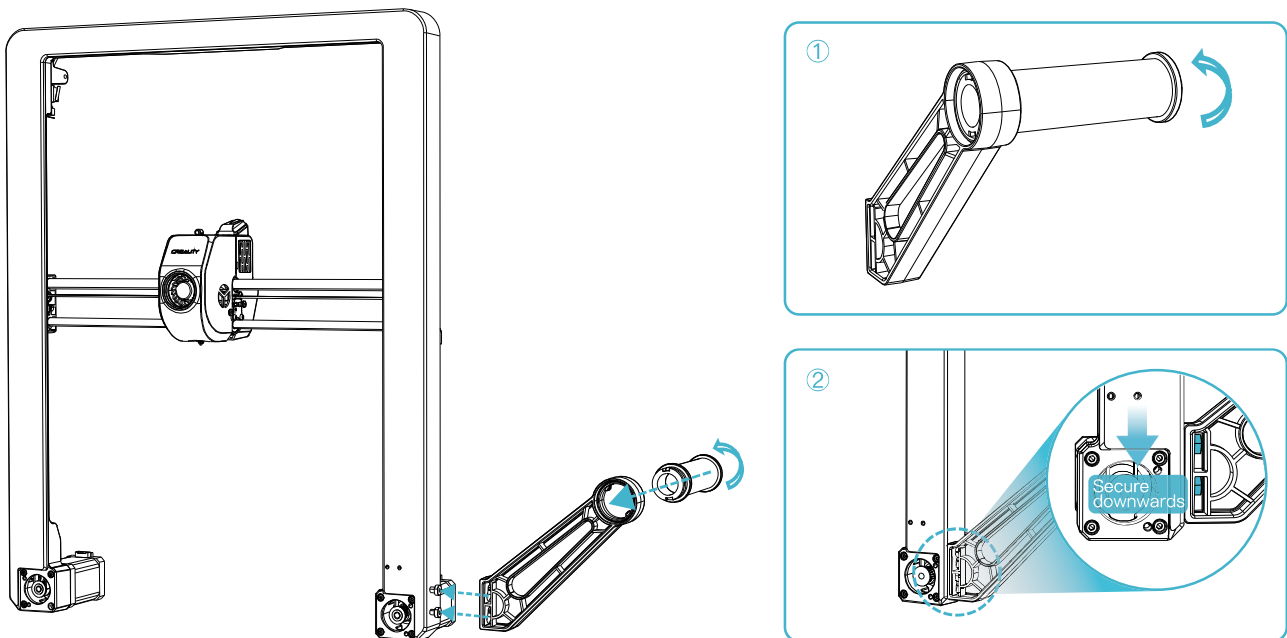

3.Assembly Procedure

3.2 Gantry Frame Assembly Installation

Place the gantry frame assembly into the slots on the base: A. First, use four M4×8 screws to align and secure the left and right screw holes on the base; B. Then, use four M4×8 screws to align and secure the screw holes on the bottom of the base.

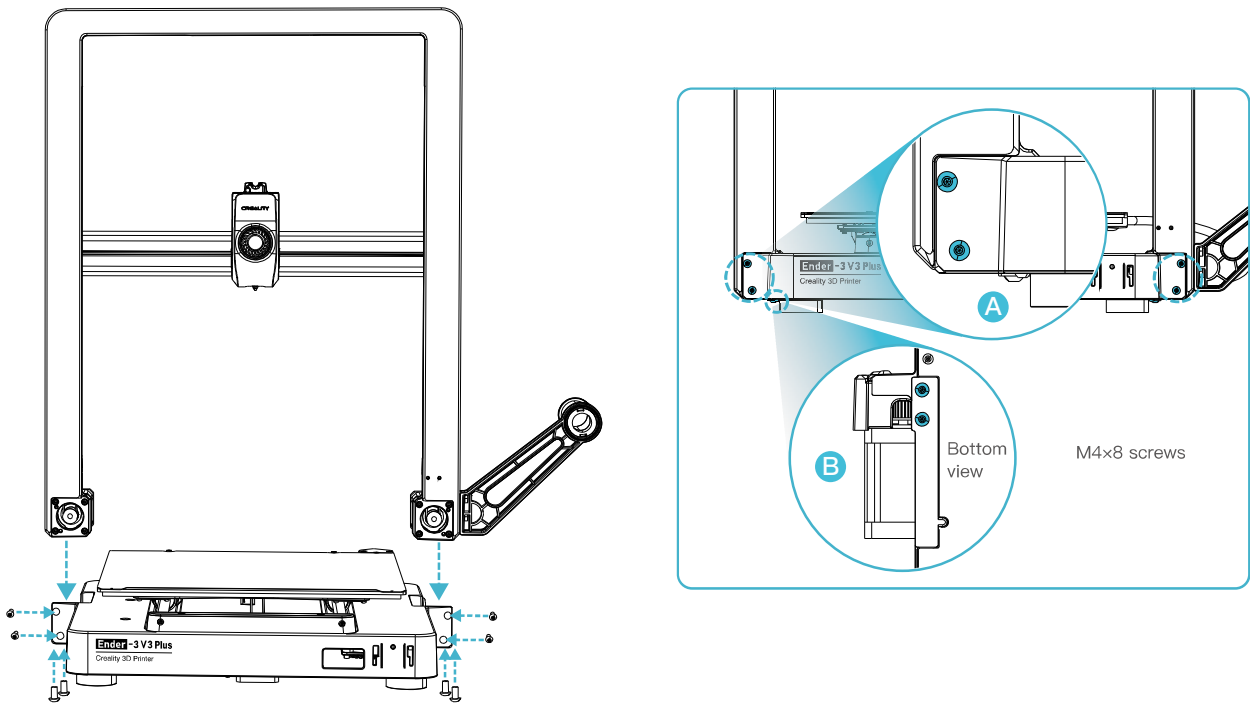

3.Assembly Procedure

3.3 Pull rod installation

- ① First, use two M4 × 10 screws to align the holes on top of the gantry and lock the screws;
- ② Then, use two M4 × 10 screws to align the holes on the base and lock them all.

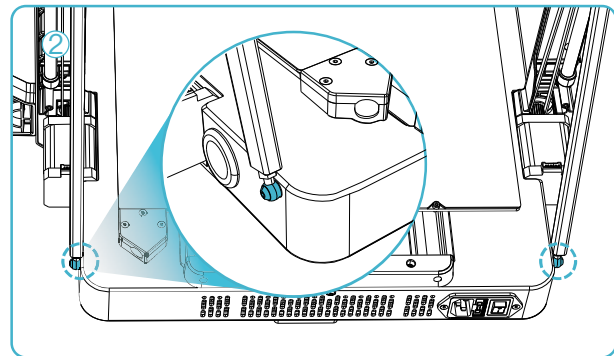
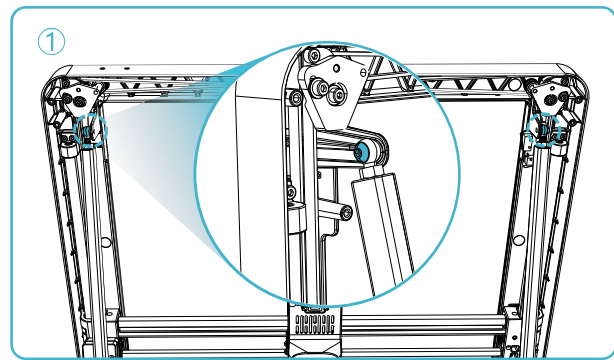
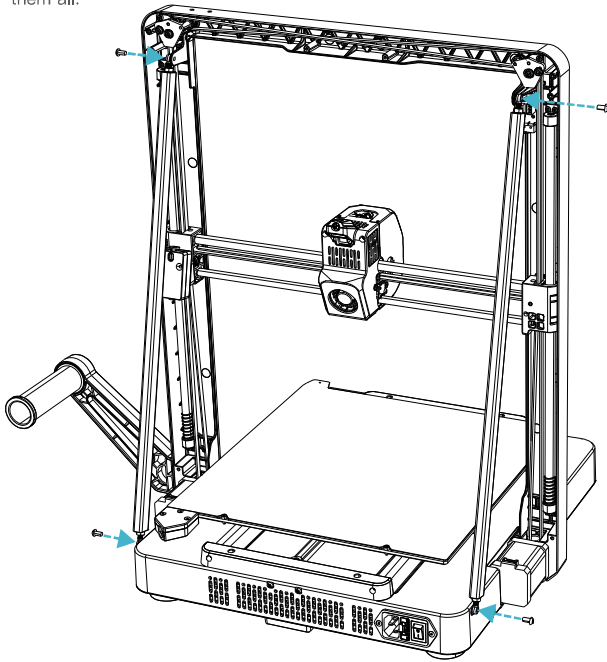

3.Assembly Procedure

3.3 Touch screen Installation

- ① Connect the touchscreen to the base screen using the flexible flat cable;
- ② Snap the buckle on the back of the touch screen into the slots on the base.

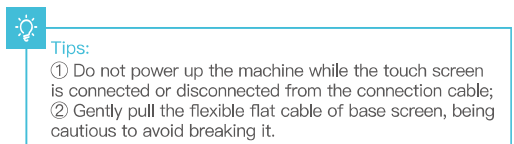
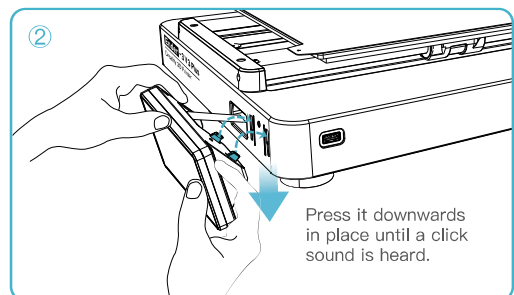
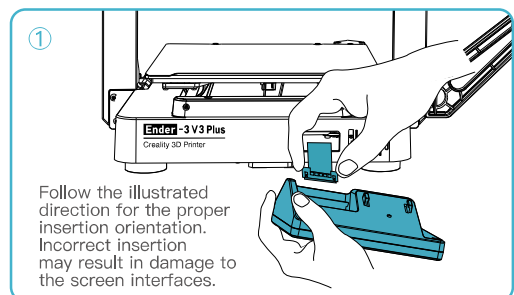
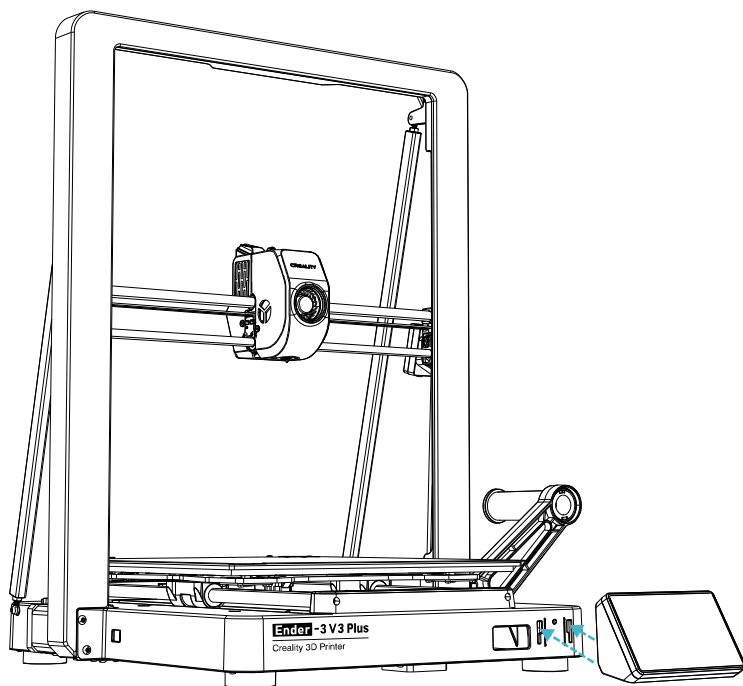

3.Assembly Procedure

3.4 Equipment Wiring

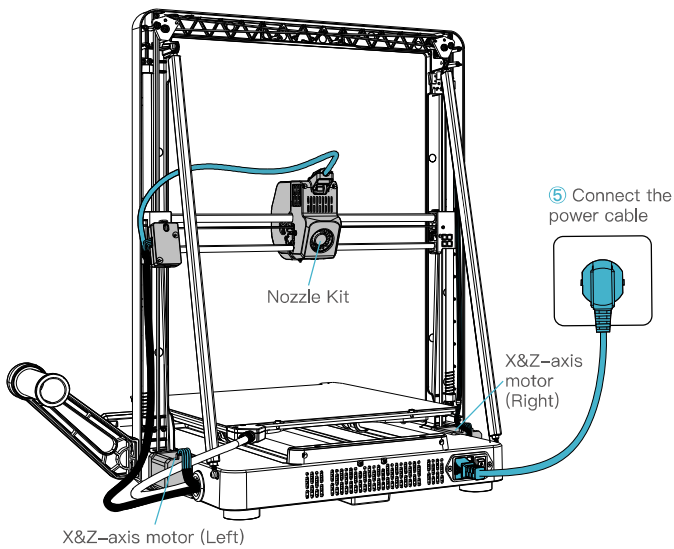

⑤ Connect the power cable

Caution

- Please ensure the correct position for the power supply switch and mains before supply connection, in order to avoid damage to the device.
- If the mains between 100V and 120V, please select the 115V for the power supply switch.
- If the mains between 200V and 240V, please select the 230V for the power supply switch (default is 230V).

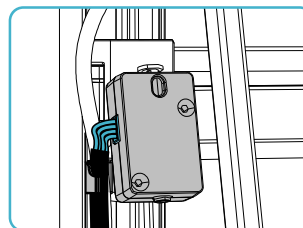

① First, clip the wire into the wire clip, and then connect the filament runout sensor line;

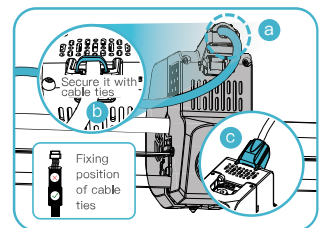

② a. Connect the extruder kit first; b. Fix the extruder cable with cable ties; c. Install the extruder cable cover;

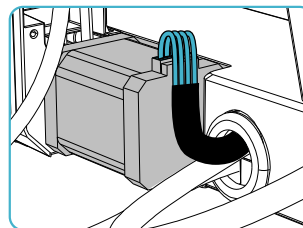

③ Connect the X&Z-axis motor (left);

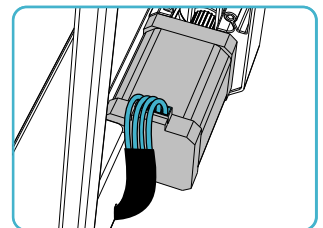

④ Connect the X&Z-axis motor (right);

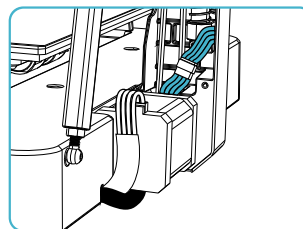

⑤ Connect the limit switch cable;

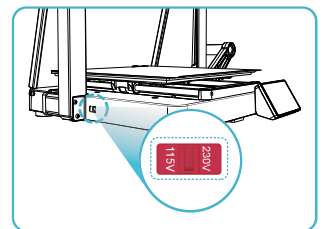

⑥ Select the correct voltage mode based on the local power grid voltage.

4.About the Power-on Guide and User Interface >>>

4.1 Power-on guide



The current interface is for reference only. Due to the continuous upgrading of functions, it shall be subject to the latest software/firmware UI published on the official website.

4.About the Power-on Guide and User Interface >>>

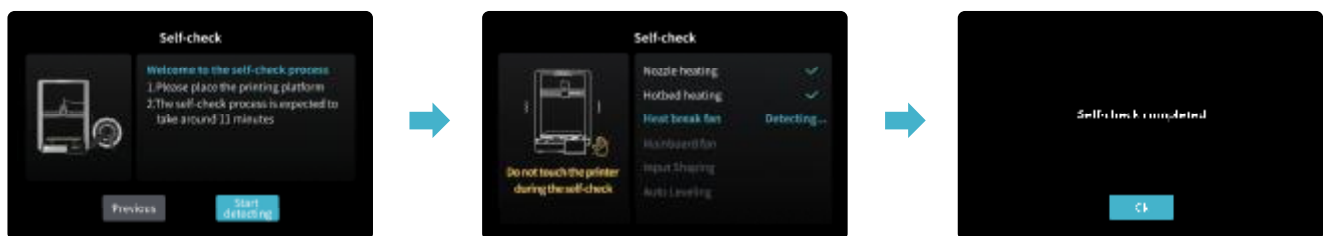

Tips:

If any abnormalities occur during the self-check process, please refer to the FAQ to check for possible machine malfunctions; Alternatively, scan the QR code for "fault reporting" to report the machine issue and seek assistance from the after-sales service for problem resolution.



The current interface is for reference only. Due to the continuous upgrading of functions, it shall be subject to the latest software/firmware UI published on the official website.

4.About the Power-on Guide and User Interface >>>

4.2 About the User Interface

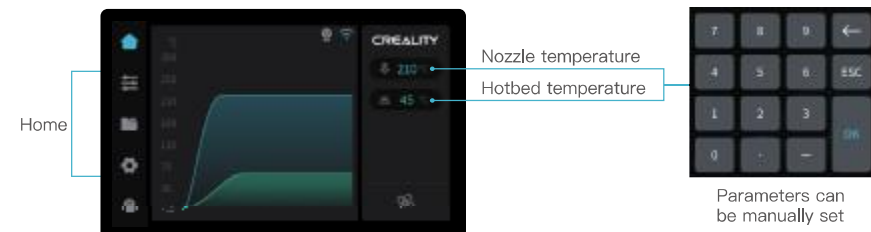

* You can configure functions such as extruder temperature and hotbed temperature through the homepage;



* You can configure functions such as axis movement/temperature control, extrude/retract, and fan cooling through the preparation interface.



The current interface is for reference only. Due to the continuous upgrading of functions, it shall be subject to the latest software/–firmware UI published on the official website.

4. About the Power-on Guide and User Interface



Print file preview

- * Press and hold on the model to select multiple models and copy them to a USB flash disk
- * Local and USB flash disk model files can be managed via the print file preview interface.



Print interface

- * Click on the model file to access its details
- * Checking "Calibration" can improve print quality

4.About the Power-on Guide and User Interface

The current interface is for reference only. Due to the continuous upgrading of functions, it shall be subject to the latest software/firmware UI published on the official website.

* You can configure functions such as system and network settings through the settings interface.

* You can view FAQs, manuals, error history and upload Log through the customer service interface .

5. First Printing

5.1 Filament Loading

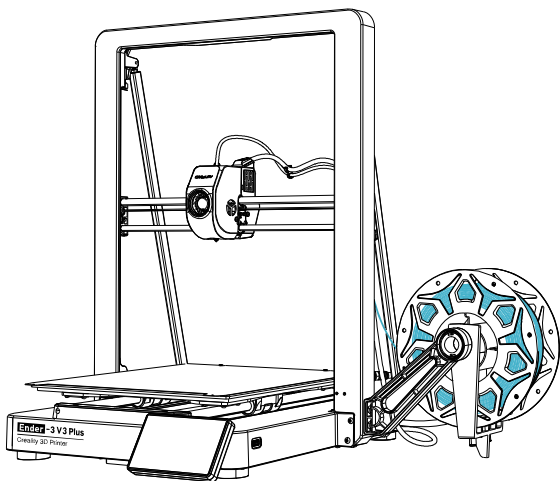

① Input the nozzle temperature on the screen and wait for it to heat up to the target temperature;

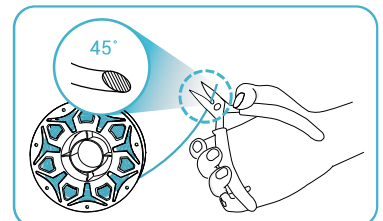

② Cut the front of the filament at 45° and break it off straight;

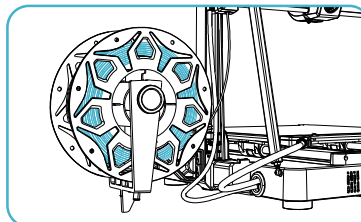

③ Arrange the filaments as shown in the picture, and then install the anti-tangle material rack;

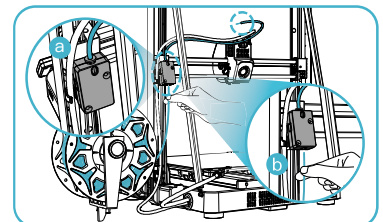

④ a. Connect the Teflon tube to filament runout sensor; b. And thread the filament into filament detection port until it passes through the Teflon tube;

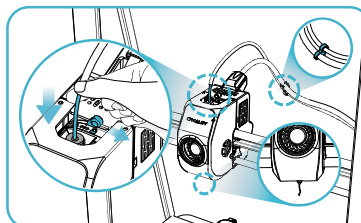

⑤ Fix the Teflon tube with extruder cable with cable clips, unlock the DIP switch and thread the filament into the extruder kit until the filament is extruded from the nozzle;

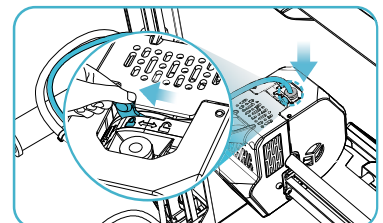

⑥ Lock the DIP switch, and insert the Teflon tube into the upper joint of the extruder kit.

5.First Printing

5.2 LAN printing

- ※ Install Crealty Print slicing software by opening the random data on the USB flash disk.
- ※ Log in to the official website to download for installation: <https://www.crealtycloud.com/software-firmware/software?type=7>

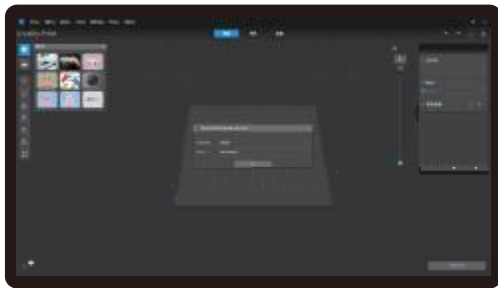

① Select "Language" and "Server"

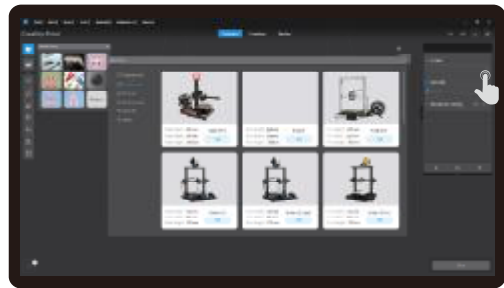

② Add the printer

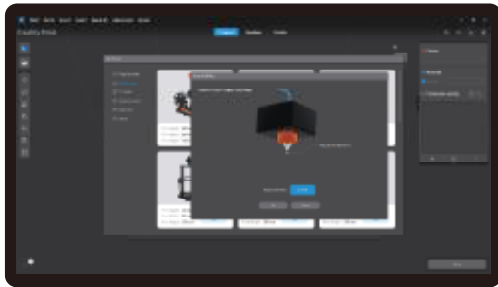

③ Confirm the nozzle diameter

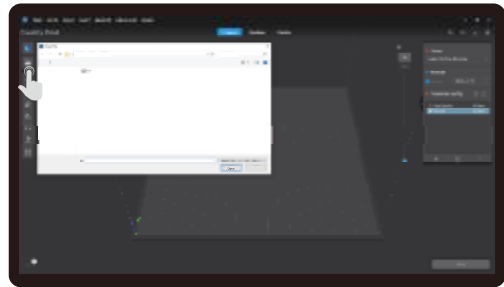

④ Import model files



The current interface is for reference only. Due to the continuous upgrading of functions, it shall be subject to the latest software/firmware UI published on the official website.

5.First Printing

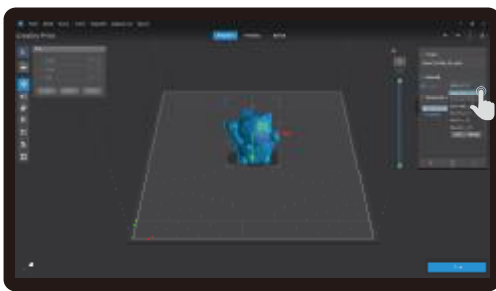

⑤ Set up material type

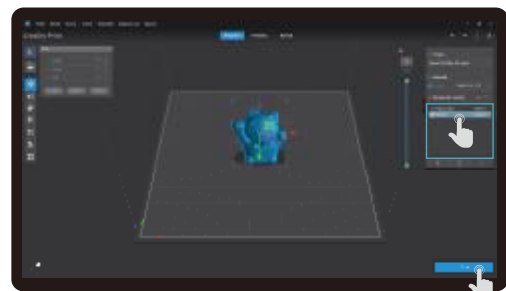

⑥ Set the print layer height and click on "Slice"

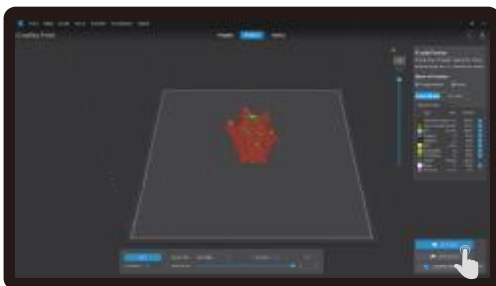

⑦ After slicing is done, click on "LAN printing"

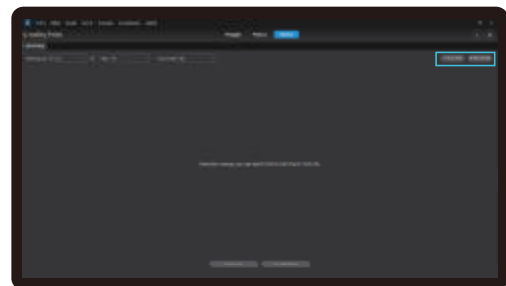

⑧ Add equipment: can be added either by "Scan Add" or "Manual Add".



The current interface is for reference only. Due to the continuous upgrading of functions, it shall be subject to the latest software/firmware UI published on the official website.

5.First Printing

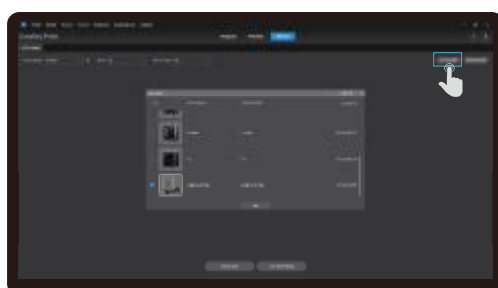

⑧ Add a device: a. Add by scanning → Select a device

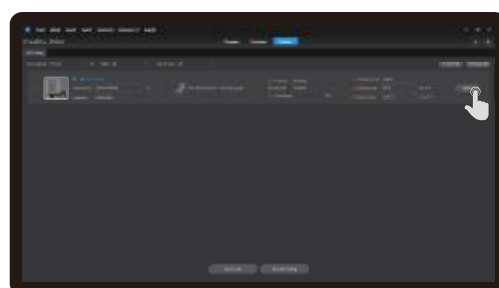

⑨ Device List



Click "Settings" →
"Network" to view
the IP address

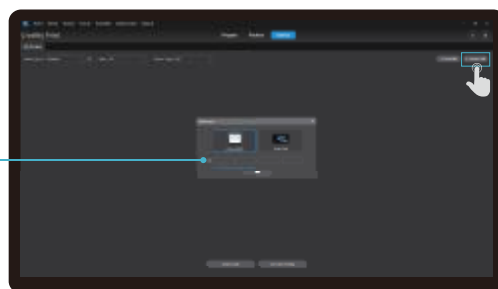

⑩ Add a device: b. Add a device by manually entering the IP address

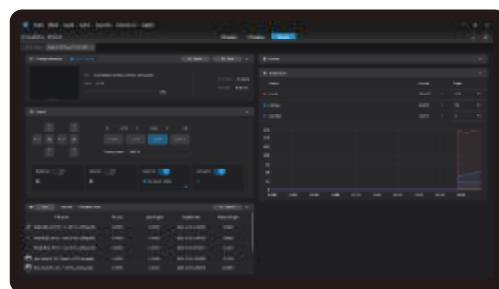

⑪ Equipment printing information details



The current interface is for reference only. Due to the continuous upgrading of functions, it shall be subject to the latest software/firmware UI published on the official website.