



CFS

User Manual

CFS Filament Management System

V 1.0_EN

To Our Dear Users

Thank you for choosing Creality. For your convenience, please read through this User Manual before you start and follow the instructions provided carefully.

Creality is always ready to provide you with high-quality services. If you encounter any issues or have any questions when using our products, please use the contact information at the end of this manual to contact us. To further improve your user experience, you can find more about our devices via the following methods:

User manual: You can find instructions and videos in the USB flash disk provided with the printer.

You can also visit our official website (<https://www.creality.com>) to find information regarding software, hardware, contact information, device instructions, device warranty information, and more.

Firmware Upgrade

1. You can upgrade the firmware directly through the device screen;
2. You can upgrade the firmware via the Creality Cloud OTA;
3. Please visit the official website <https://www.creality.com>, click on “Support → Download Center” , select the corresponding model to download the required firmware, (Or click on “Creality Cloud → Downloads → Firmware”) , after installation is complete, you can use it.

Product Operation and After-Sales Service Information

1. You can log in to the Creality Official Wiki (<https://wiki.creality.com>) to explore more detailed after-sales service tutorials.
2. Or contact our after-sales service center at +86 755 3396 5666, or send e-mail to cs@creality.com.



Creality Wiki

1. Do not use the printer in any way other than that described herein in order to avoid personal injury or property damage;
2. Do not place the printer near any heat source or flammable or explosive objects. We suggest placing it in a well-ventilated, cool and dustless environment;
3. We recommend the use of Creality Hyper plastic tray series filaments, which have been tested extensively;
4. Do not use the power cable of other products during installation. Always use the attached power cable and be sure that the power plug must be plugged into a grounded three-prong power outlet;
5. To avoid material blockage, do not use TPU or damp PVA or BVOH for printing;
6. Do not wear gloves or wraps while operating the machine to prevent entrapment of movable parts that could cause crushing and cutting injuries to bodily parts;
7. To prevent the tray from getting stuck, do not use cardboard trays with untreated edges or cardboard trays that are deformed as a whole;
8. Users should comply with the laws and regulations of the corresponding countries and regions where the equipment is located (used), abide by professional ethics, pay attention to safety obligations, and strictly prohibit the use of our products or equipment for any illegal purposes. Creality will not be responsible for any violators' legal liability under any circumstance.
9. Tip: Do not plug in or unplug wires on a charged basis.





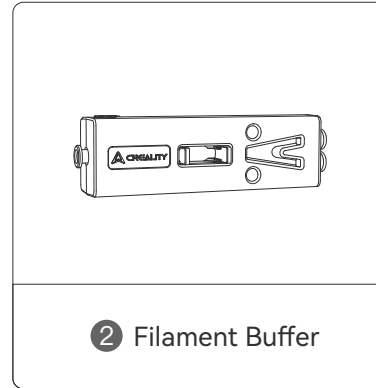
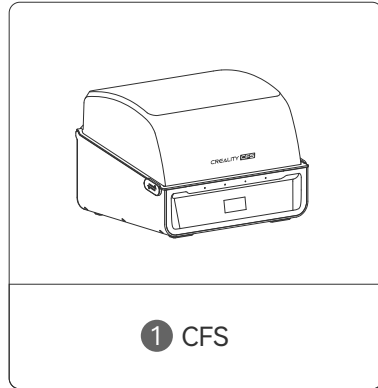

1. Equipment Information	01-04
1.1 Packing List	01-01
1.2 Introduction to Equipment	02-03
1.3 Equipment Parameters	03-03
1.4 Equipment Size and Recommended Installation Size	04-04
2. Unboxing	05-07
2.1 Connecting CFS to K2 Plus	05-07
3. CFS Usage	08-10
3.1 CFS Filament Editing/Reading	08-08
3.2 Connecting Multiple CFSs for Use	09-10

1. Equipment Information



1.1 Packing List



✂ Accessory kit			
 <p>① Hexagonal wrench</p>	 <p>② Filament Buffer cable</p>	 <p>③ Creality 485 cable</p>	 <p>④ PTFE Tube</p>
 <p>⑤ Quick Guide</p>	 <p>⑥ After-sales service card</p>	Tips: the above accessories are for reference only. Please refer to the physical accessories.	

1. Equipment Information

1.2 About the Equipment

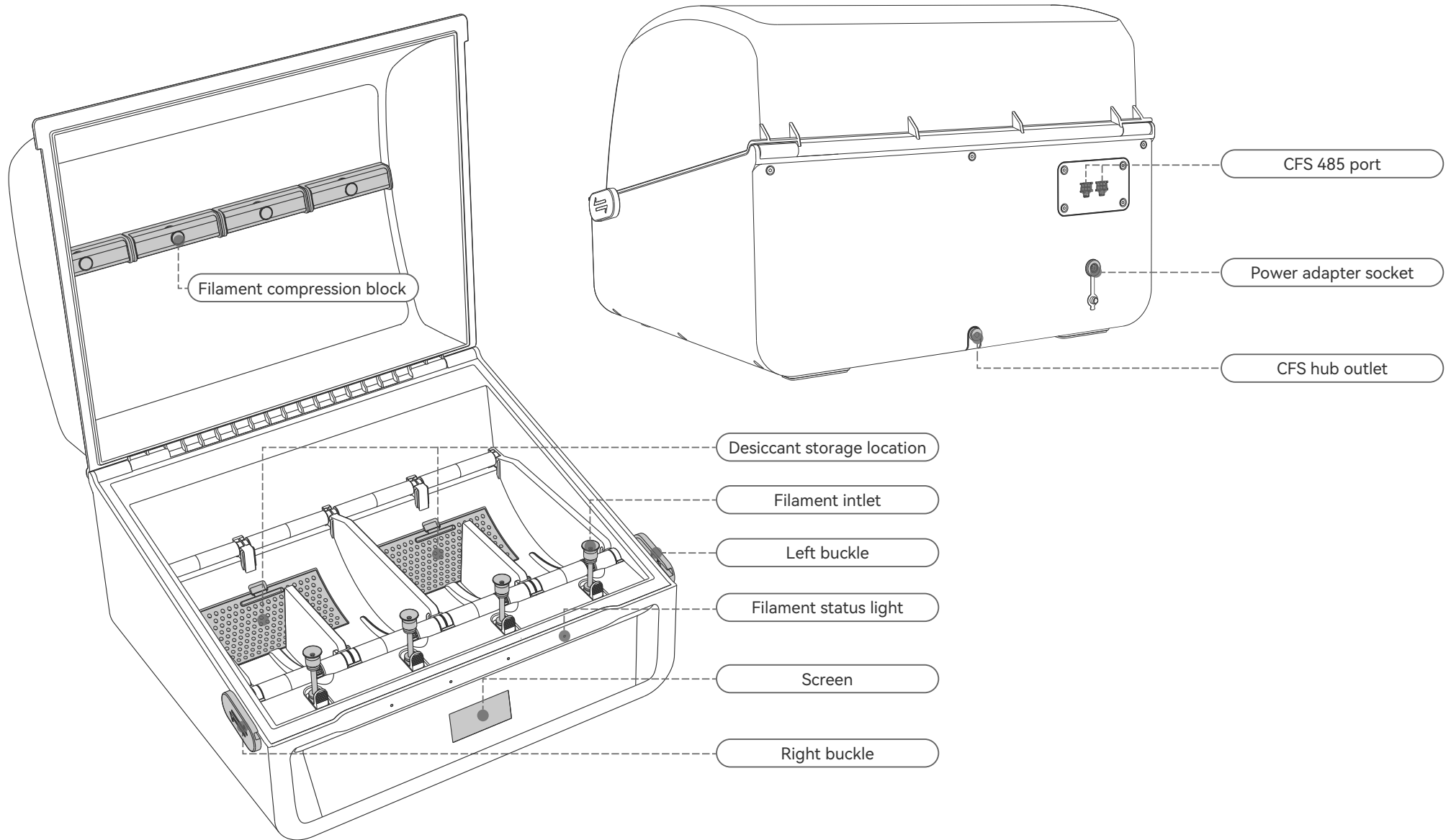

1. Equipment Information



1.3 Equipment Specifications

Basic Parameters	
Model	CFS
Number of silos	4
Rated Power	20W
Rated Voltage	DC 24V
Expandable number	≤4
Product size	379*314*276mm
Net weight	4.56kg
Filament status multi-function indicator light	Four [one for each channel]
Multi-color printing	Yes
Automatic refilling	Yes
RFID identification	Yes
Filament detection	Yes
Buffer	Yes
Drying	Desiccant method
Compatible filament types	PLA/ABS/PETG/ASA/PET/PA-CF/PLA-CF...(not compatible with damp water-soluble supports, not compatible with soft filaments with hardness of TPU95A and below)
Filament diameter	1.75±0.05mm
Filament roll compatibility	1kg料卷或料卷直径: 197-202mm料卷厚度: 42-68mm

1. Equipment Information

1.4 Equipment Size and Recommended Installation Size

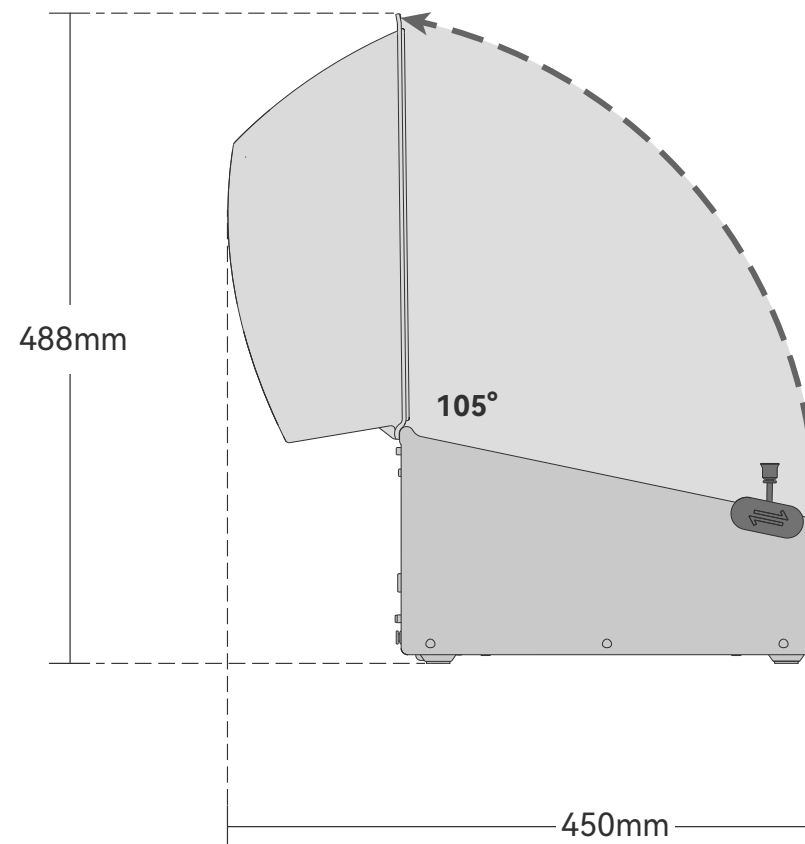
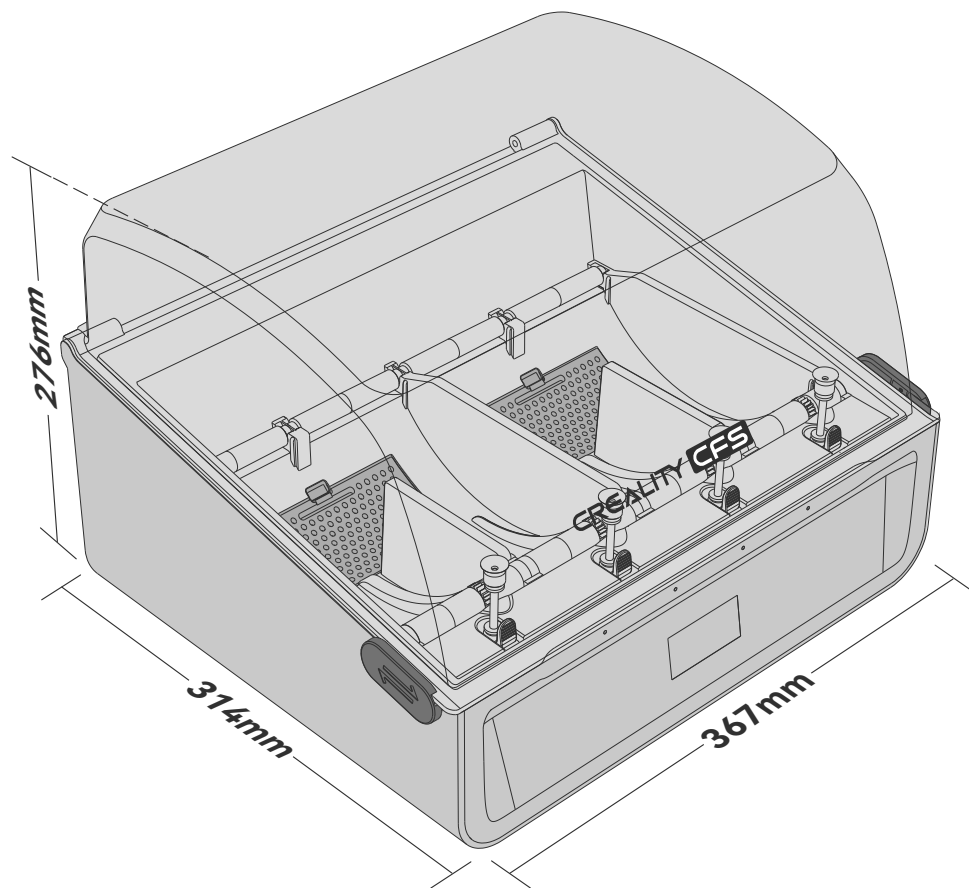

2. Unboxing

2.1 Connecting CFS to K2 Plus

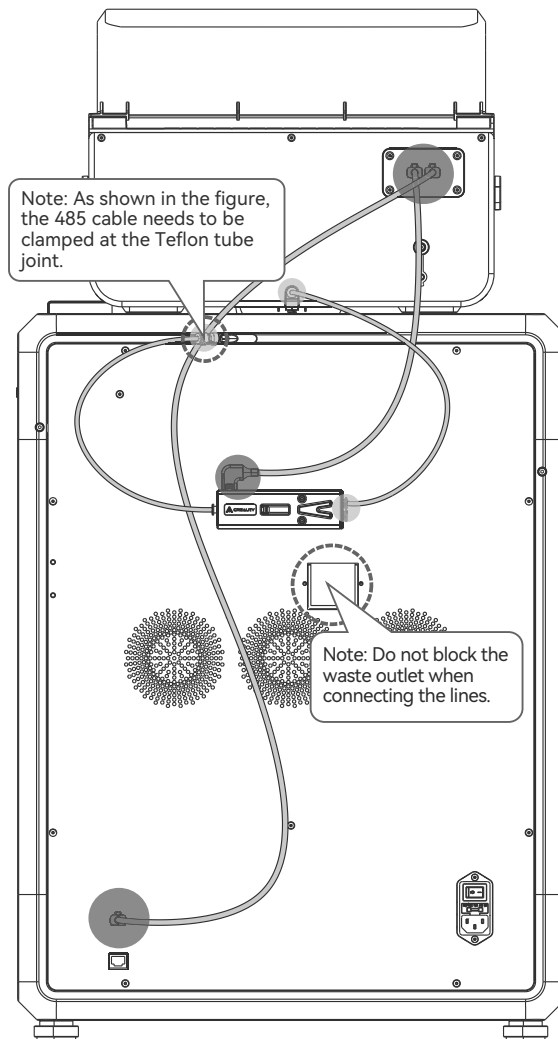

Note: As shown in the figure, the 485 cable needs to be clamped at the Teflon tube joint.

Note: Do not block the waste outlet when connecting the lines.

- The green circle is the connection point of the 485 cable;
- The yellow circle is the connection point of the PTFE tube.

2.1.1 Install the filament buffer

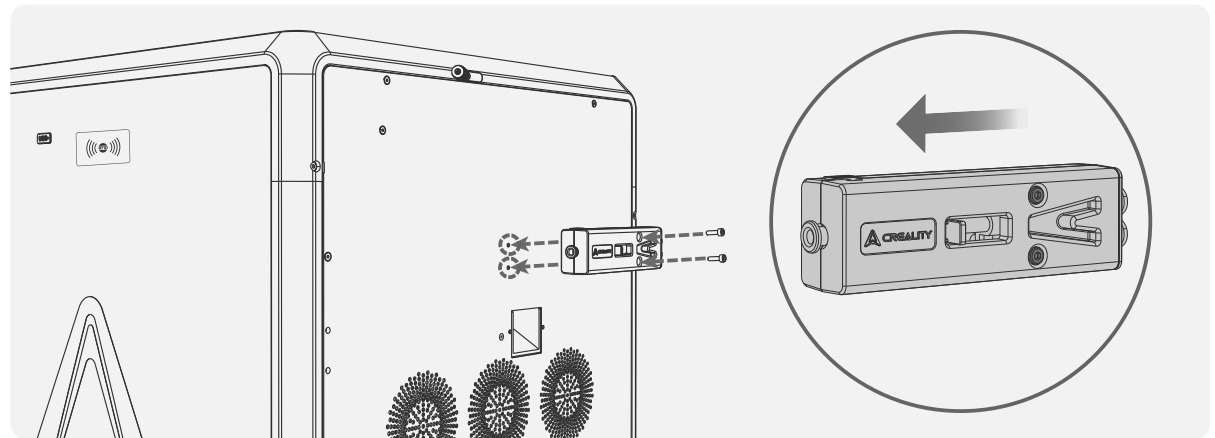

- 1 Install the filament buffer on the back of the machine and tighten it with two buffer screws; pay attention to the direction of the buffer, do not install it in a wrong direction;

2.1.2 Connect the Teflon tube and 485 communication line

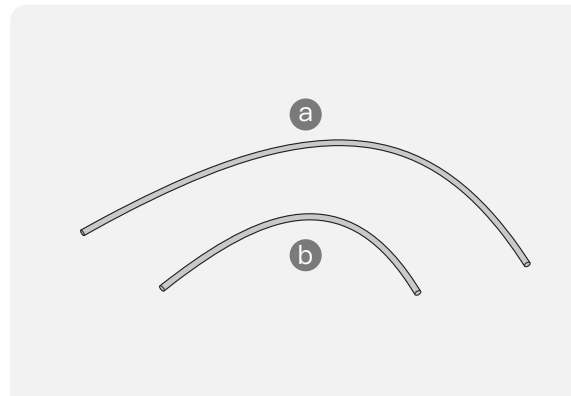

- The longer PTFE tube a is used to connect the CFS five-way joint and the buffer; The shorter PTFE tube b is used to connect the CFS buffer and the printer.

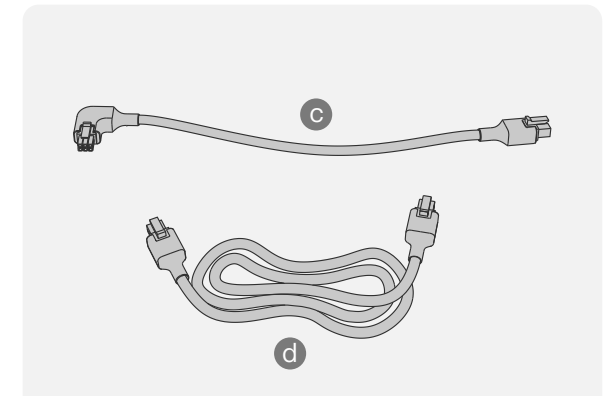

- The shorter 485 communication line c is used to connect the CFS and the buffer; The longer 485 communication line d is used to connect the CFS and the printer.

2. Unboxing

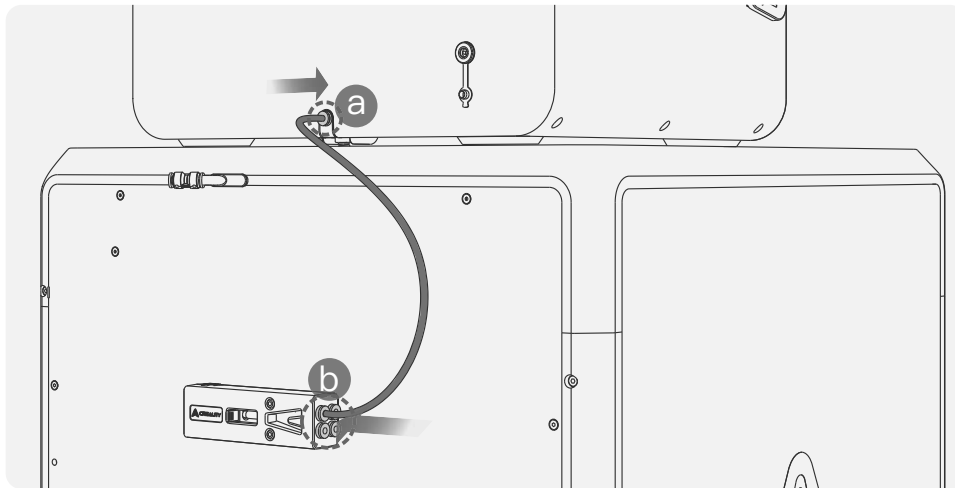

- 1 Connect CFS five-way joint and buffer: insert one end of the longer Teflon tube into the CFS hub outlet (position a); insert the other end into the buffer (position b, any of the four holes);

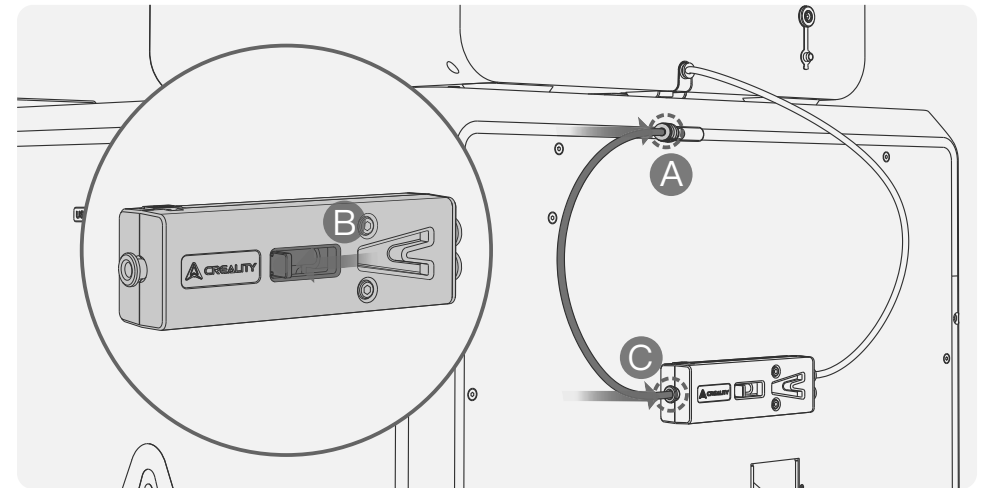

- 2 Connect the buffer and K2 Plus according to steps A, B, and C;

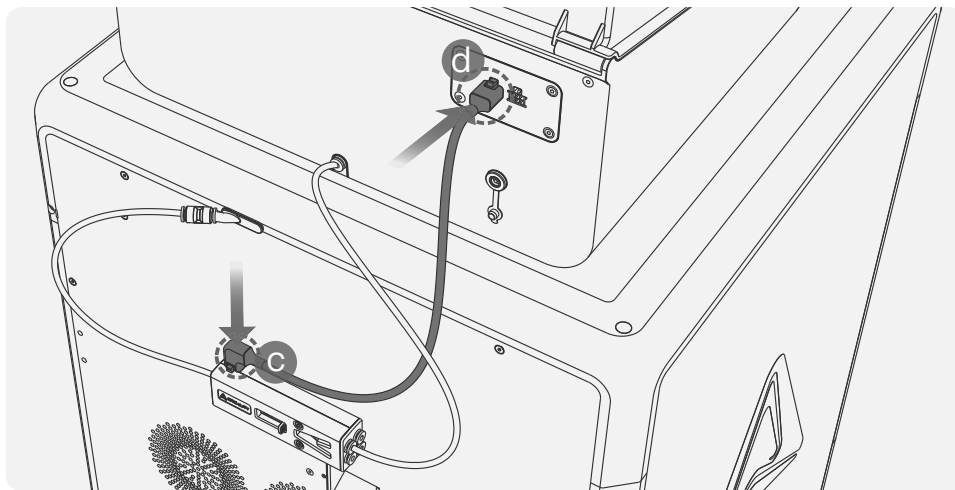

- 3 Connect CFS and buffer 485 communication line: Note that the elbow is inserted into the buffer position c, and the straight head is inserted into the CFS position d (either of the two 485 sockets of CFS);

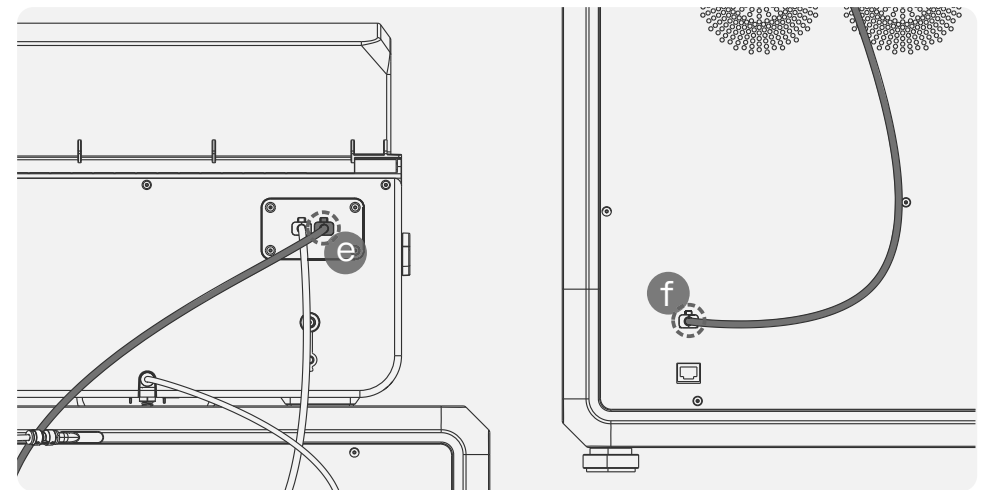

- 4 Connect CFS and K2 Plus 485 communication line: Both ends of this line are 6-pin straight heads, one end is inserted into the CFS position e, and the other end is inserted into the machine interface position f.

2. Unboxing

2.1.3 Unpack the desiccant and put it into CFS

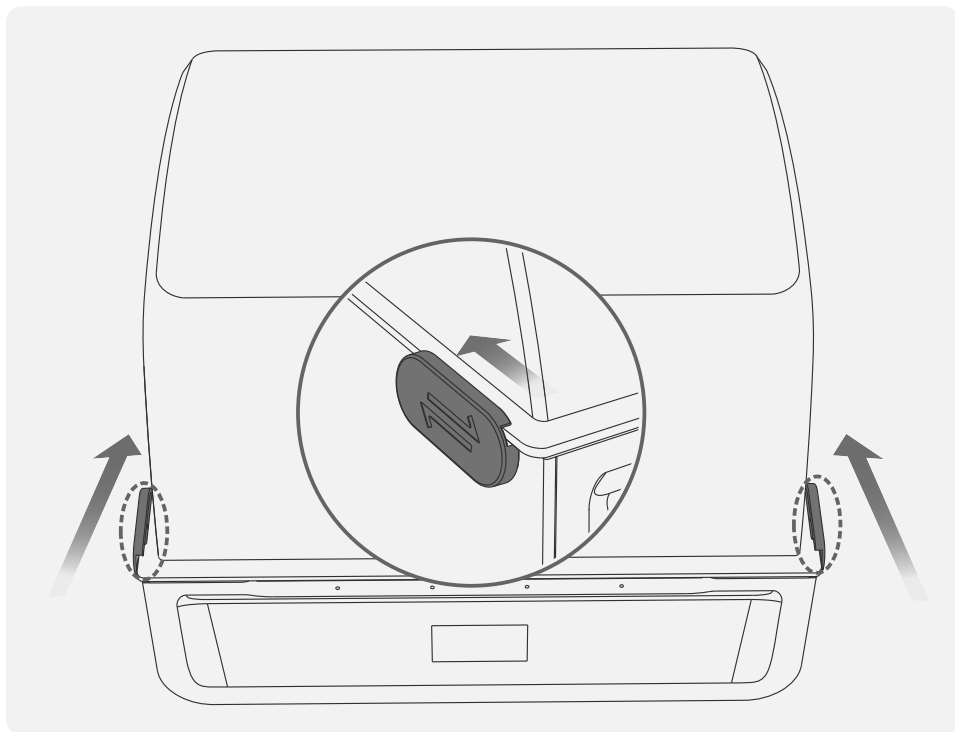

- 1 Open CFS: Push the locking buckles on both sides of CFS to the back to unlock and open the top cover;

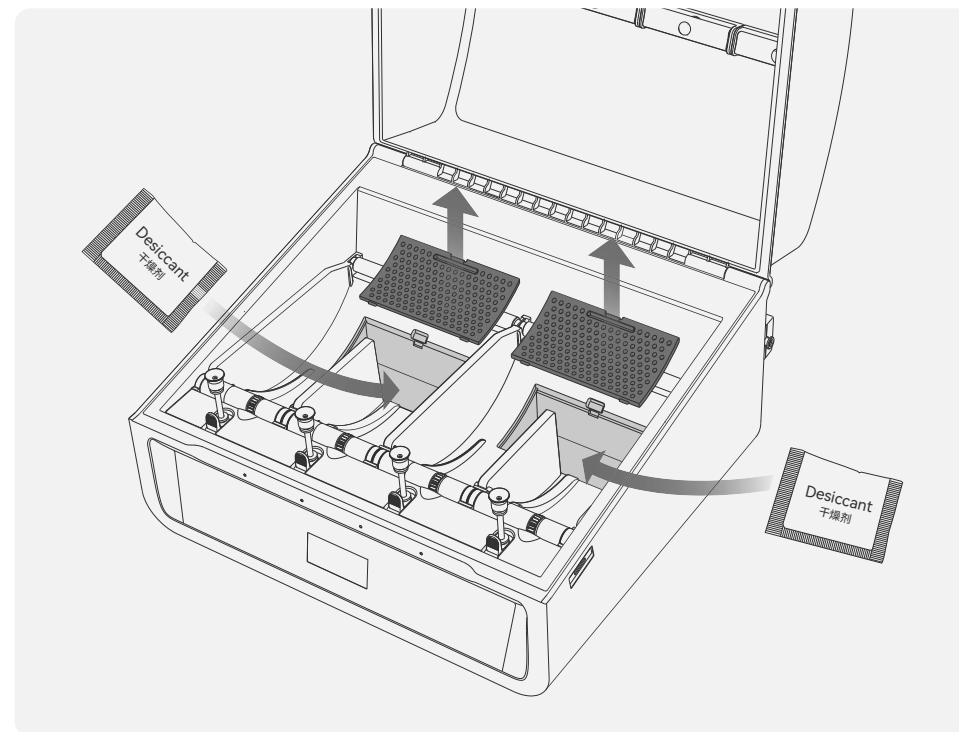

- 2 Find the desiccant storage location, open the top cover and put the desiccant in, and then put the top cover back.



Tear off the film on the surface of the desiccant first, and then put the desiccant into the CFS.

3. Product Usage

CFS cannot be used alone and needs to be connected to a printer:

3.1 CFS Filament Editing/Reading



To prevent the tray from getting stuck, do not use cardboard trays with untreated edges or cardboard trays that are deformed as a whole.



- a is the pre-loading button, which can be used to read filament. If the reading is successful, the remaining filament and filament color will be displayed. If the reading fails, the filament editing button will be displayed, and the filament will be displayed as "?";
- b is the empty silo state, displayed as "/", and editing is not supported;
- c means that the RFID filament is read, the eye icon is for viewing filament information, RFID filament only support viewing; if this is RFID and you want to use non-RFID next time, click the pre-loading button, wait for the reading to complete, and then click the filament editing button;
- d is ordinary filament, which support editing;
- e is the state where RFID is not read, the filament display "?". At this time, you need to click the edit button to manually edit the filament information;
- f is the CFS humidity status. Green means the humidity is appropriate, orange means the humidity is slightly higher, and red means the humidity is very high. The desiccant may need to be replaced.

- 1 Introduction to the filament management interface: The filament management page is divided into two parts: the external material rack [left] and the CFS [right]. The code above the filament in the CFS, such as 1A, indicates the silo number;

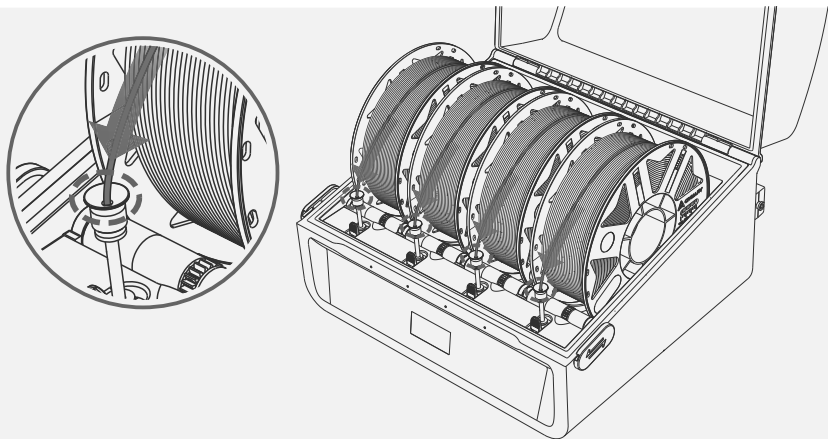

Loading filament: Put the filament into the CFS, align the filament head with the Teflon tube of corresponding silo, push it in gently, and let go after feeling the pulling force. The filament will be automatically loaded.

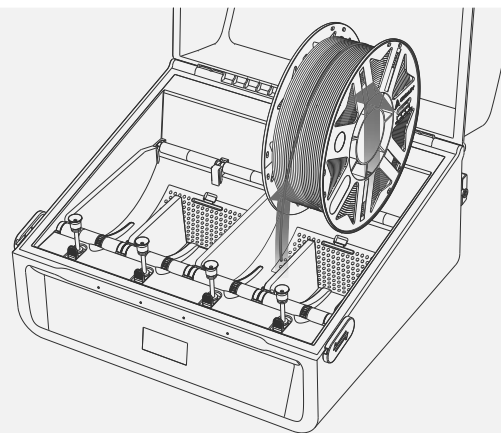

Unloading filament: First, make sure that the filament is not in the extruder, in this case, just pick up the filament and pull it out; if it is in the extruder, click the Retract button first, wait for the filament to return to the CFS, and then take out the filament.

- 2 Load/unload filament.

3. Product Usage

3.2 Product Usage

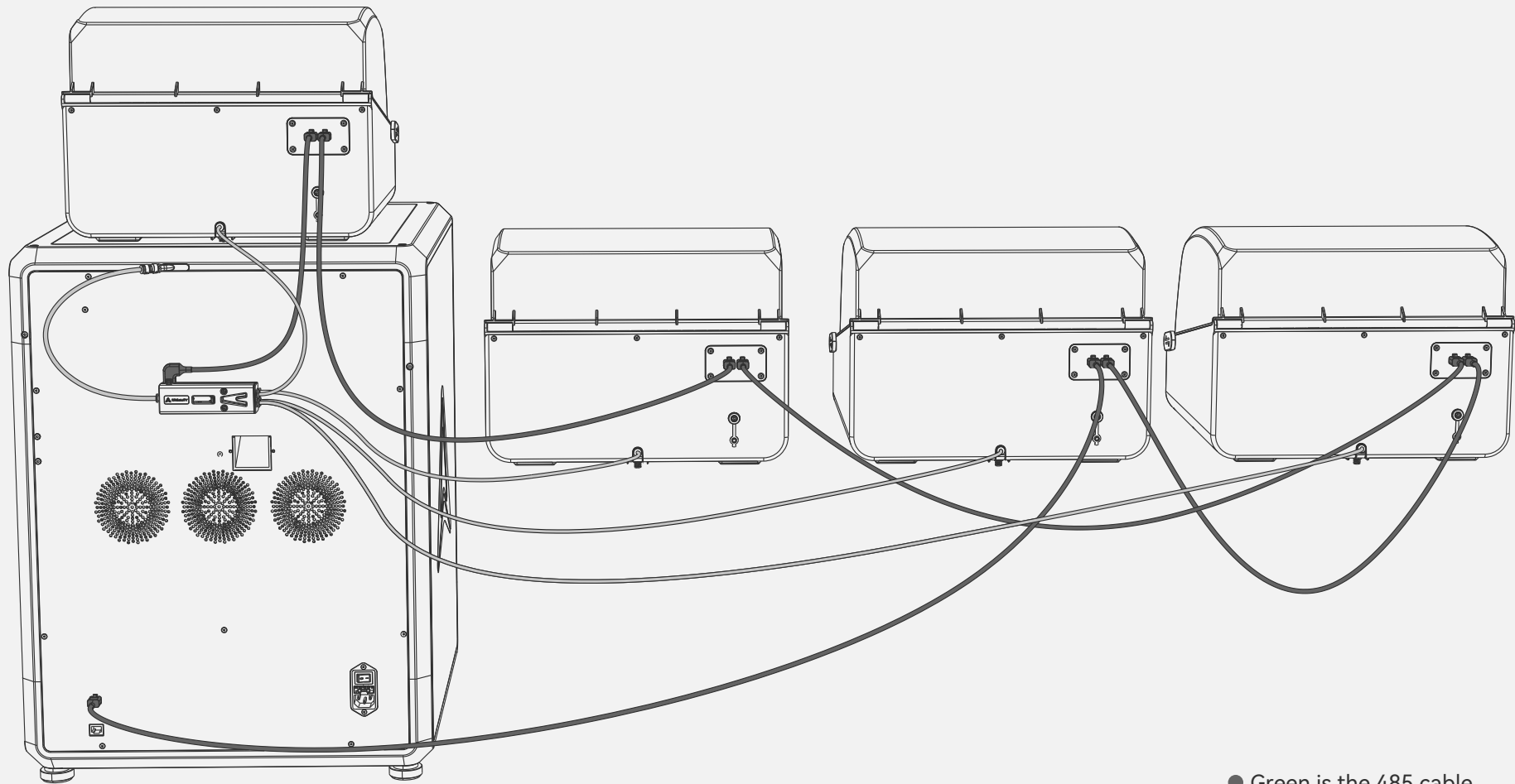

- Green is the 485 cable
- Yellow is the PTFE tube

3. Product Usage



One to one

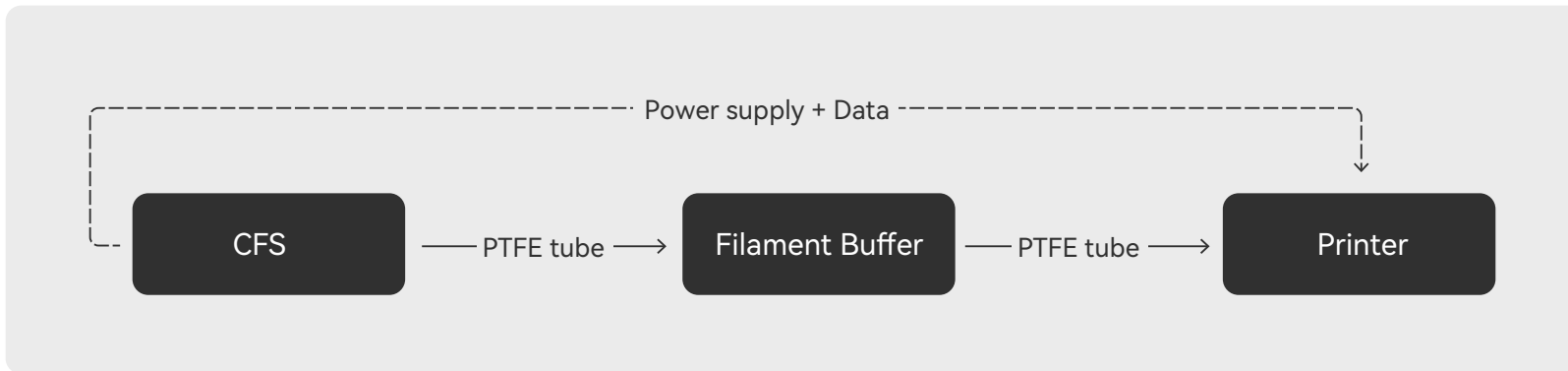

One to four

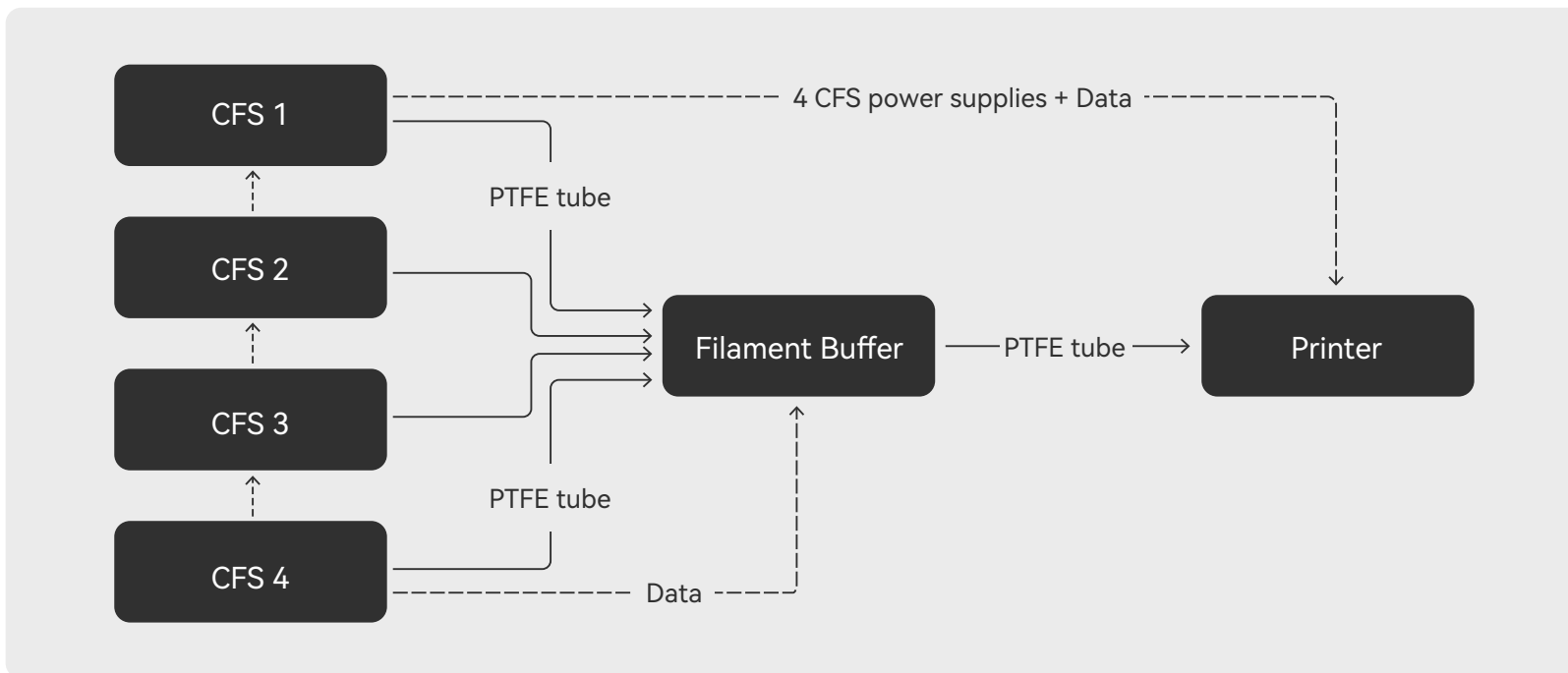

For pluggable equipment, the socket-outlet shall be easily accessible.

Do not use this apparatus near water.

Clean only with dry cloth.

Only use attachment/accessories specified by the manufacturer.

Unplug this apparatus during lightning storms or when unused for long periods of time.

Refer all servicing to qualified service personnel. Servicing is required when the apparatus has been damaged in any way, such as power-supply cord or plug is damaged, liquid has been spilled or objects have fallen into the apparatus, the apparatus has been exposed to rain or moisture, does not operate normally, or has been dropped.

Internal/External Voltage Selectors : Internal or external voltage selector switches, if any, should only be reset and re-equipped with a proper plug for alternative voltage by a qualified service technician. Do not attempt to alter this yourself. Protective earthing terminal : The apparatus should be connected to a mains socket outlet with a protective earthing connection.

When moving or not using the appliance, secure the power cord (e.g., wrap it with a cable tie). Be careful not to damage the power cord. Before using it again, make sure the power cord has not been damaged. If the power cord has been damaged at all, bring the unit and cord to a qualified service technician for repair or replacement as specified by the manufacturer.

Disconnect power cord before servicing.

Replace critical components. only with factory parts or recommended equivalents.

CAUTION: TO REDUCE THE RISK OF ELECTRIC SHOCK, DO NOT REMOVE ANY COVER. NO USER- SERVICEABLE PARTS INSIDE. REFER SERVICING TO QUALIFIED SERVICE PERSONNEL ONLY.

Pour les équipements enfichables, la prise de courant doit être facilement accessible.

N'utilisez pas cet appareil près de l'eau.

Nettoyez uniquement avec un chiffon sec.

N'utilisez que les fixations/accessoires spécifiés par le fabricant.

Débranchez cet appareil pendant les orages ou lorsqu'il n'est pas utilisé pendant de longues périodes.

Confiez toutes les réparations à un personnel qualifié. Un entretien est nécessaire lorsque l'appareil a été endommagé de quelque manière que ce soit, par exemple lorsque le cordon d'alimentation ou la fiche sont endommagés, lorsqu'un liquide a été renversé ou que des objets sont tombés dans l'appareil, lorsque l'appareil a été exposé à la pluie ou à l'humidité, lorsqu'il ne fonctionne pas normalement ou lorsqu'il est tombé.

Sélecteurs de tension internes/externes : Les sélecteurs de tension internes ou externes, le cas échéant, ne doivent être réinitialisés et rééquipés d'une fiche appropriée pour la tension alternative que par un technicien de service qualifié. N'essayez pas de le modifier vous-même. Borne de mise à la terre de protection : L'appareil doit être connecté à une prise de courant avec une connexion de mise à la terre de protection.

Lorsque vous déplacez l'appareil ou que vous ne l'utilisez pas, fixez le cordon d'alimentation (par exemple, enroulez-le avec un serre-câble). Veillez à ne pas endommager le cordon d'alimentation. Avant de l'utiliser à nouveau, vérifiez que le cordon d'alimentation n'a pas été endommagé. Si le cordon d'alimentation a été endommagé, apportez l'appareil et le cordon à un technicien de service qualifié pour qu'il le répare ou le remplace comme indiqué par le fabricant.

Débranchez le cordon d'alimentation avant de procéder à l'entretien.

Remplacez les composants critiques. uniquement avec des pièces d'usine ou des équivalents recommandés.

ATTENTION : POUR RÉDUIRE LE RISQUE DE CHOC ÉLECTRIQUE, NE RETIREZ AUCUN COUVERCLE. AUCUNE PIÈCE RÉPARABLE PAR L'UTILISATEUR À L'INTÉRIEUR. NE CONFIEZ L'ENTRETIEN QU'À UN PERSONNEL QUALIFIÉ.

FCC WARNING

This device complies with part 15 of the FCC Rules. Operation is subject to the following two conditions:

(1) this device may not cause harmful interference, and (2) this device must accept any interference received, including interference that may cause undesired operation.

Any changes or modifications not expressly approved by the party responsible for compliance could void the user's authority to operate the equipment.

NOTE: This equipment has been tested and found to comply with the limits for a Class B digital device, pursuant to Part 15 of the FCC Rules. These limits are designed to provide reasonable protection against harmful interference in a residential installation. This equipment generates, uses and can radiate radio frequency energy and, if not installed and used in accordance with the instructions, may cause harmful interference to radio communications.

However, there is no guarantee that interference will not occur in a particular installation.

If this equipment does cause harmful interference to radio or television reception, which can be determined by turning the equipment off and on, the user is encouraged to try to correct the interference by one or more of the following measures:

- Reorient or relocate the receiving antenna.
- Increase the separation between the equipment and receiver.
- Connect the equipment into an outlet on a circuit different from that to which the receiver is connected.
- Consult the dealer or an experienced radio/TV technician for help.

radiator your body: Use only the supplied antenna.

Due to the differences between different machine models, the actual objects and the images can differ. Please refer to the actual machine. The final explanation rights shall be reserved by Shenzhen Creality 3D Technology Co., Ltd.



SHENZHEN CREALITY 3D TECHNOLOGY CO., LTD.

18th Floor, JinXiuHongDu Building, Meilong Road, Xinniu Community,
Minzhi Street, Longhua District, Shenzhen City, China.

Official Website: www.creality.com

Tel: +86 755-8523 4565

E-mail: cs@creality.com

