

HELMET WIRELESS EARPHONE

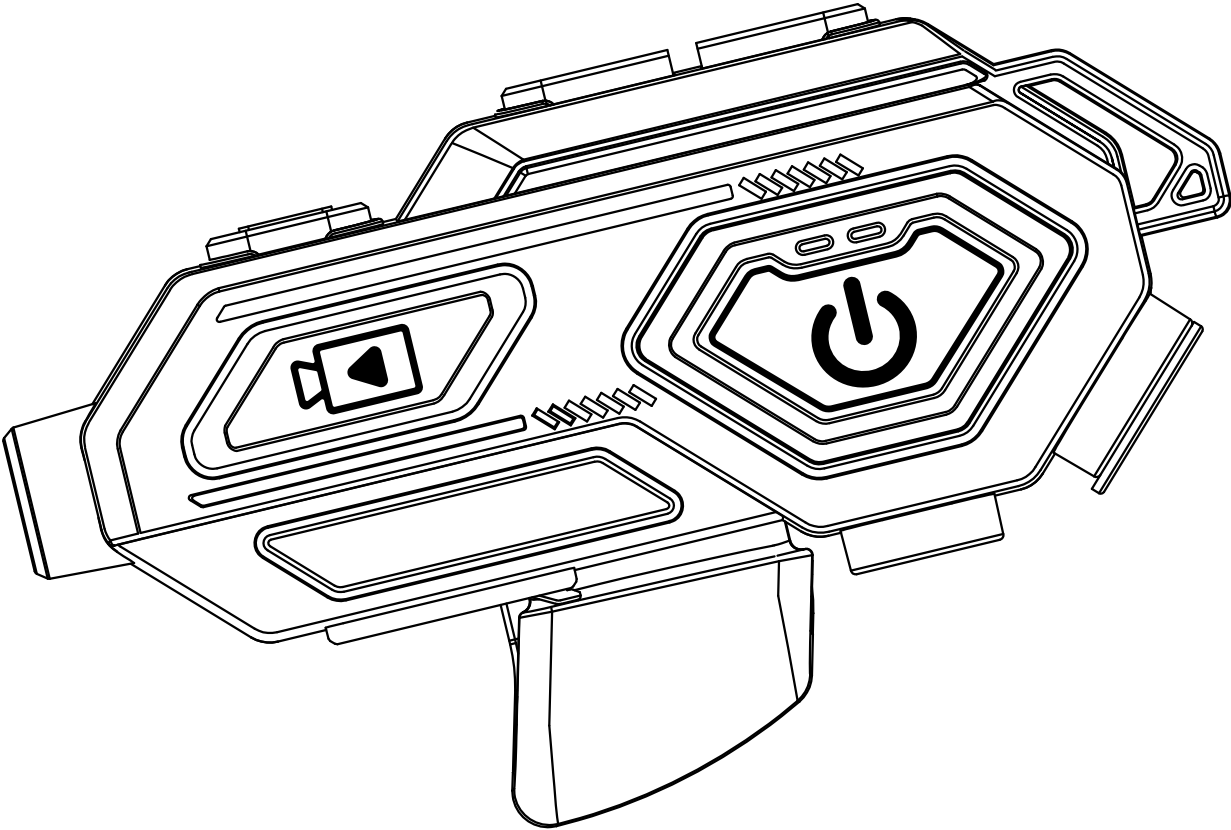

C8 Max

NOTE: This equipment has been tested and found to comply with the limits for a Class B digital device, pursuant to part 15 of the FCC Rules. These limits are designed to provide reasonable protection against harmful interference in a residential installation. This equipment generates, uses and can radiate radio frequency energy and, if not installed and used in accordance with the instructions, may cause harmful interference to radio communications. However, there is no guarantee that interference will not occur in a particular installation. If this equipment does cause harmful interference to radio or television reception, which can be determined by turning the equipment off and on, the user is encouraged to try to correct the interference by one or more of the following measures:

- Reorient or relocate the receiving antenna.
- Increase the separation between the equipment and receiver.
- Connect the equipment into an outlet on a circuit different from that to which the receiver is connected.
- Consult the dealer or an experienced radio/TV technician for help

Changes or modifications not expressly approved by the party responsible for compliance could void the user's authority to operate the equipment.

This device complies with Part 15 of the FCC Rules. Operation is subject to the following two conditions:

(1) this device may not cause harmful interference, and (2) this device must accept any interference received, including interference that may cause undesired operation.

FCC RF Exposure Warning Statement:

This equipment complies with FCC radiation exposure limits set forth for an uncontrolled environment. This equipment can be used in portable exposure conditions.

English **01–10**

French **11–20**

German **21–30**

Italian **31–40**

Spanish **41–50**

User Manual

Product Overview

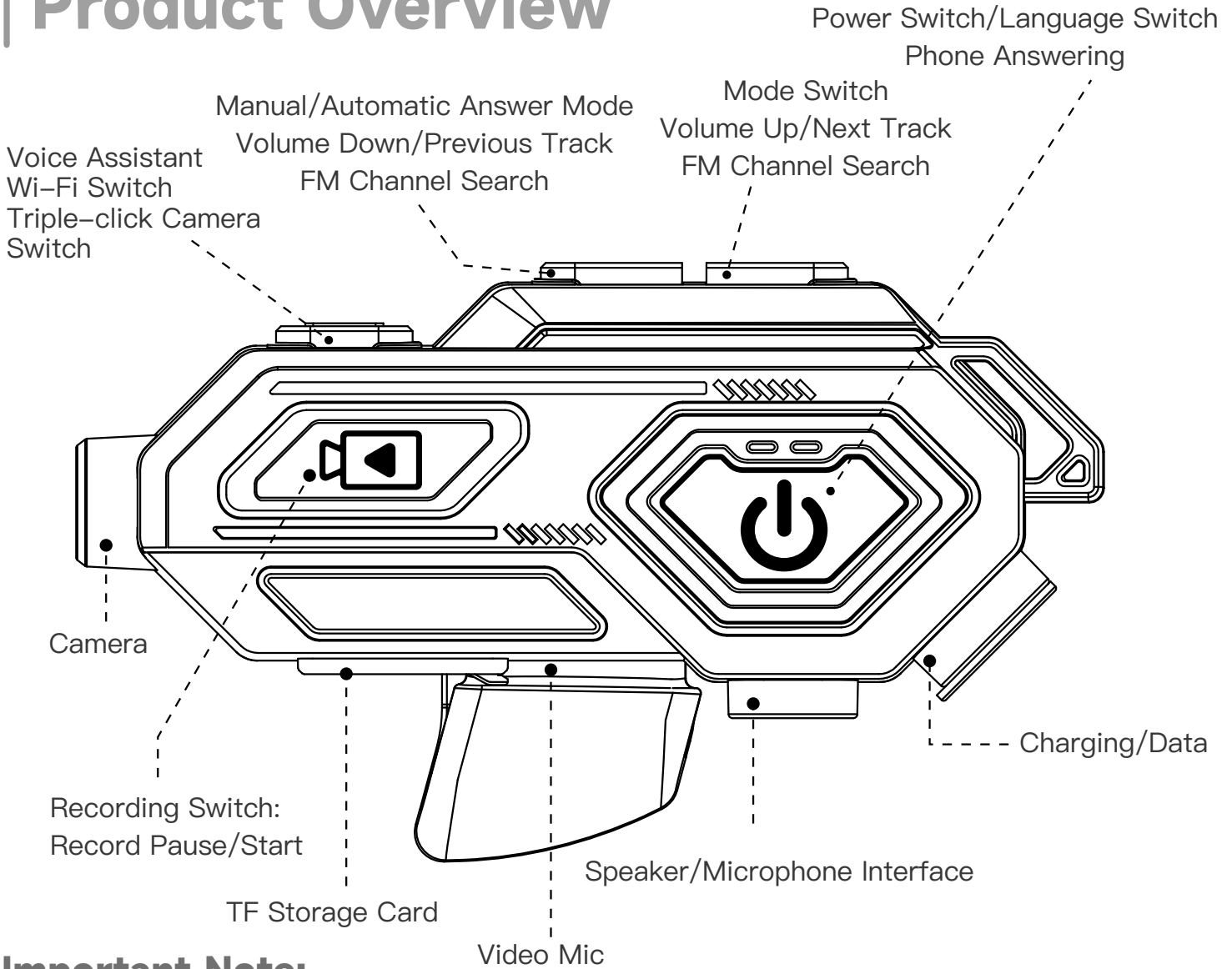

Important Note:

1. Connect to the phone to test volume and check TF card before installing headphones.
2. Adjust speaker position in helmet if volume differs after installation. Charge device if low battery warning occurs.
3. High power consumption is normal; Bluetooth function may be available after low battery shutdown.

• Phone Functions

Double-tap Volume (-)

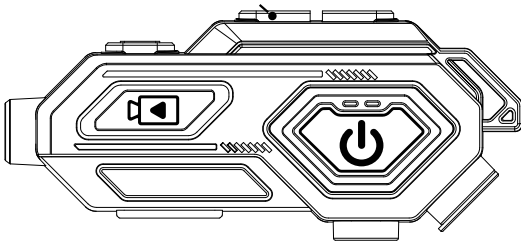

→
(When connected to Bluetooth)

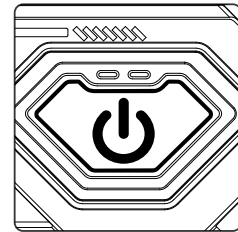

Switch between manual automatic answer mode

(mode switch when not connected to phone)

Automatic Mode (Auto answer after ⌚ 10 seconds)

During a call, double-tap power button to switch between phone and device answering



(Incoming Call)
(After ⌚ 10 seconds)

Automatic

Automatic Answer



(Incoming Call)

Manual Answer
for Incoming Call

Answer



(Incoming Call)

Hold for 2 seconds

Reject Call



(Currently on call)

"Short Press"
During Call

End Call



Double-tap

Redial Last Number



(While continuing
the call)

Short Press

Cancel Current Call

• Power On/Off

▶ Turn On/Off Power

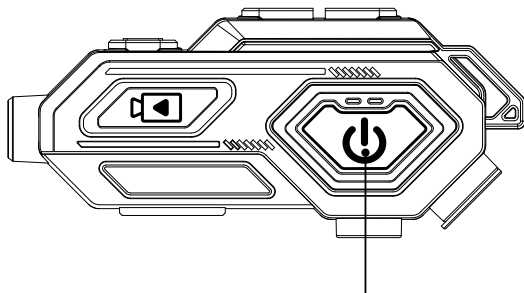

→
(Voice Prompt)

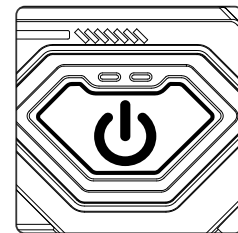

LED Light On

Long press for 3 seconds to turn on the device

• Pairing Phone and Headphones

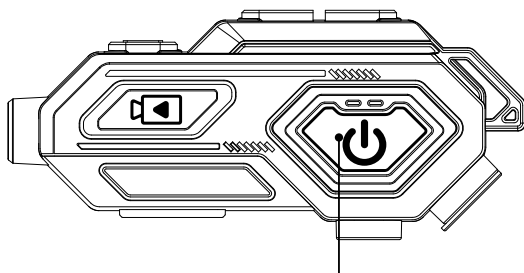

→
(Voice Prompt)

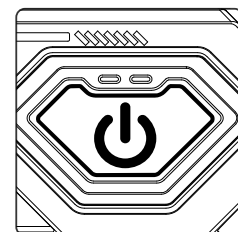

Bluetooth Not Connected,
LED Blinking

Bluetooth Connected, LED
Blinking Intermittently

• Charging Mode

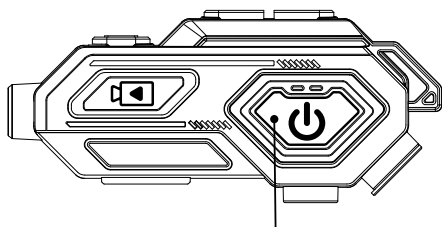

Indicator Light On
While Charging

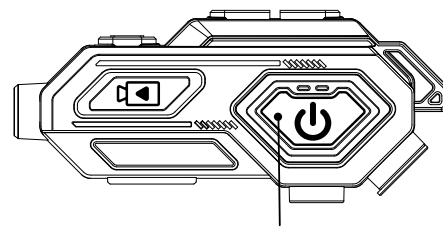

Indicator Light Turns Off
When Fully Charged

(When the device is on, plugging in the charger will automatically turn off the device)

• Music Function

▶ Pause/Play Music



→
(Music Stopped)



Paused

→
(Music Playing)



Playing

Short Press

Volume Down Button

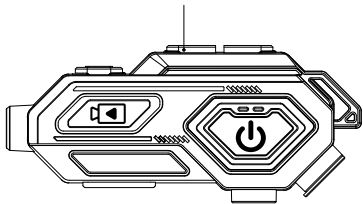

Short Press for
Previous Track

→
(Music Playing)

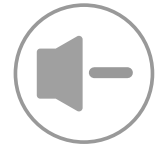

Long Press to
Decrease Volume

Volume Up Button

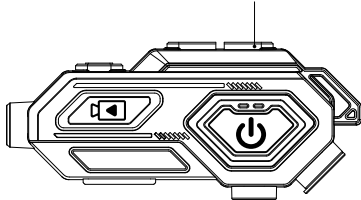

Short Press
for Next Track

→
(Music Playing)



Long Press to
Increase Volume

• Voice Assistant

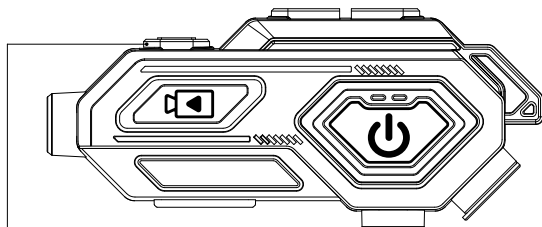

Voice Assistant Button

→
Short Press



Wake Up Voice Assistant

• Music Sharing Pairing

- Double-click the WiFi button on devices A/B, and devices A/B will enter music sharing pairing mode, with the power button's colored LED indicator flashing quickly.
- Once devices A/B are paired successfully, the power button's colored LED indicator will flash intermittently.

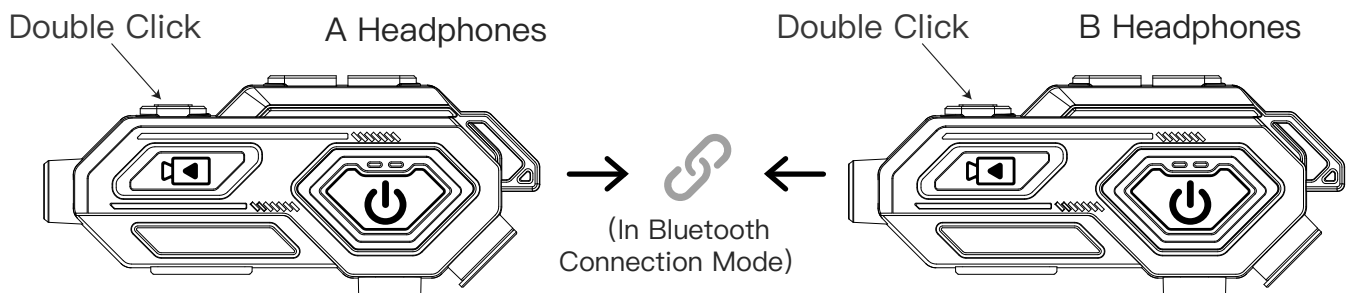

Note:

1. In music sharing mode, if devices A and B are disconnected, the power button's indicator light will flash quickly to alert.
2. In music sharing mode, the volume up/down and play buttons on devices A and B can control the phone.

• Talkie Pairing On/Off

- Double-click the volume "+" button on devices A/B, and devices A/B will enter talkie pairing mode, with the power button's green LED indicator flashing quickly.
- Once devices A/B are paired successfully, the power button's green LED indicator will flash intermittently.

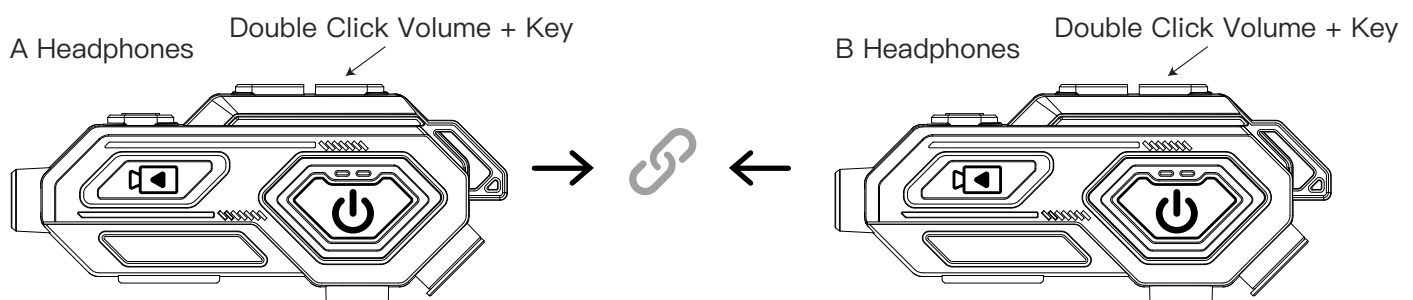

Note:

1. In talkie mode, if devices A and B are disconnected, the power button's green indicator light will flash quickly to alert.
2. If devices A and B experience lag or interruption, they will automatically reconnect when brought close.
3. When switching to talkie mode, the phone's Bluetooth connection will disconnect automatically; when switching back to Bluetooth mode, the headphones will reconnect to the phone automatically.

● FM Mode

- Double-click the “+” volume button to enter FM mode, the power button’s orange LED indicator blinks intermittently.
- Short press the volume up/down buttons, and the device will enter semi-automatic search mode, pausing the search when a clear radio signal is found, sequentially searching for stations (the speaker cable must be plugged in during the search).

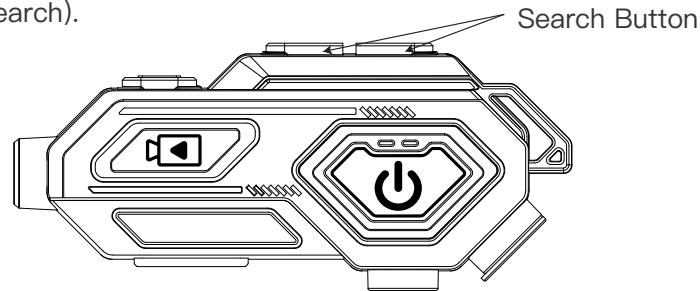

Note:

1. In FM mode, if you do not want to listen to the broadcast, you can press the power button to mute; pressing it again will return to the sound state.
2. Depending on the environment, there may sometimes be a “hissing” sound; please try to use it outdoors or in open areas

● Recording Function (Dashcam)

- Press and hold the recording switch for 5 seconds to turn on/off; it will start recording automatically after power on.
- Short press the recording button to pause/start while recording.

The green LED flashes when powered on, and flashes slowly during recording

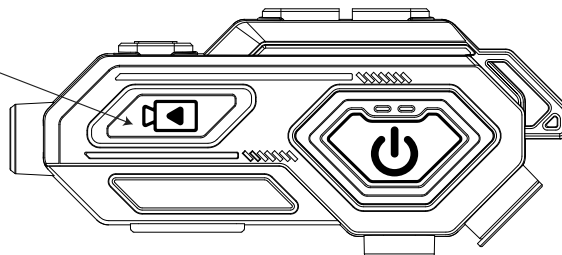

≤256G/C10

Note:

1. Video files on the TF storage card are stored in segments of 2 minutes (the time length can be set via the app).
2. The dashcam has high power consumption; when the battery is low, it will shut down immediately after being turned on. The Bluetooth function (which has low power consumption) can continue to be used after the automatic shutdown, which is normal.
3. Some TF cards with certain speeds may not be compatible with this device; it supports a maximum capacity of 256G with a write speed of C10; cards below C10 are not supported.
4. If the system detects that the TF card is not inserted after power on, the device will automatically shut down after 3 minutes.
5. The dashcam system has high power consumption; it may slightly heat up after long use. The device has a temperature detection feature, so please use it with confidence.

• Wifi Function (Hotspot)

- Press and hold the Wi-Fi switch for 5 seconds to turn it on/off. After turning on, the phone is not connected to the backup hotspot. It will automatically turn off after 5 minutes.

The orange LED will blink when turned on, and will blink slowly after connecting to the phone.

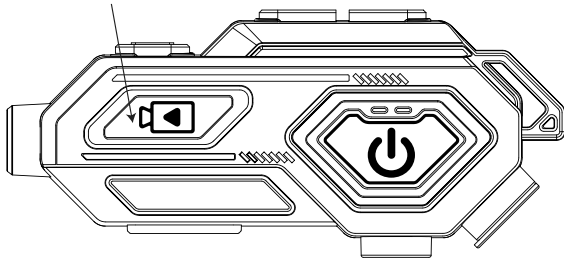

APP



APP

Note:

1. Open an Android or iOS device and search for the app name "Roadcam/GoPlus cam" in the app market or App Store to download and install, or scan the QR code in WeChat to download; and allow access to information services and camera.
2. The search paths may vary slightly depending on the device; please follow the prompts on the user's phone interface for installation.
3. During the connection process of the device APP to the phone, no other WiFi hotspots can be connected.
4. WiFi hotspot password: 12345678 (can be modified within the app).

• Wifi+APP Function (Hotspot) Installation and Usage

- Long press the WiFi key for 5 seconds to turn it on/off. After powering on, the orange LED blinks quickly. (The recording function must be enabled before turning on the Wi-Fi.)

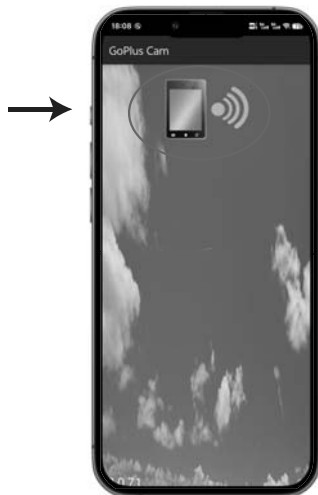
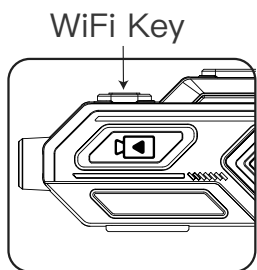

Click on the downloaded app to enter this page, click the connection icon, and it will automatically jump to the Wi-Fi interface.

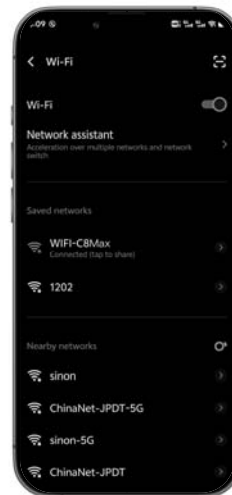

Enter this page, click on C8-Max and enter the initial password: 12345678 to connect successfully



Return to the app home page and click the icon to enter.

Note:

1. To return to the main operation interface of the APP, swipe up from the bottom right corner of the phone screen.
2. Contents in the storage card can be copied and deleted by connecting to a computer via a USB data cable.
3. Gsonser functionality and sensitivity can be toggled on or off in the APP.

Click the file icon in the upper left corner to view recorded videos and stored images.



Click the settings icon in the upper right corner to access various parameter settings.

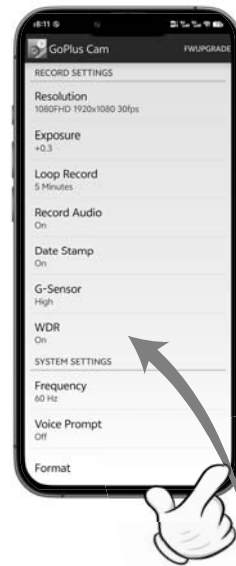

To return to the main operation interface of the APP, swipe up from the bottom right corner of the phone screen.

Camera Interface



Disconnect

Pause/Continue

Click the icon in the lower right corner to switch between video recording and photo-taking modes.

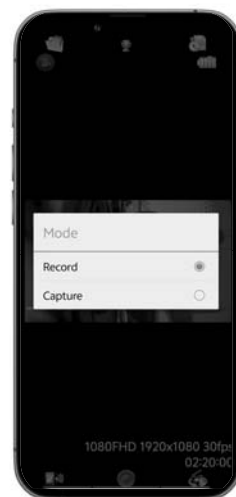

• USB Mode

- The product can be used to connect to a computer for copying and deleting videos and photos

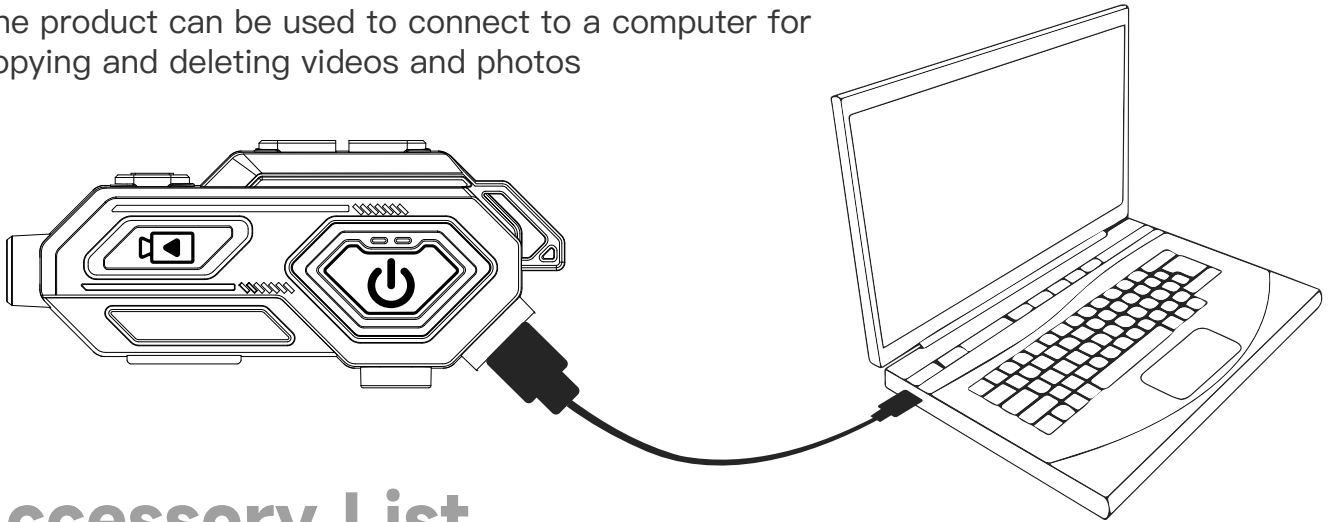

• Accessory List

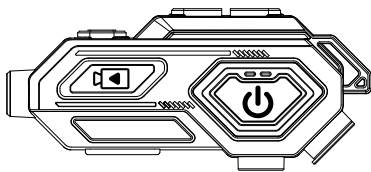

C8Max*1

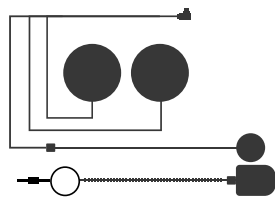

Headphone and
Microphone*1

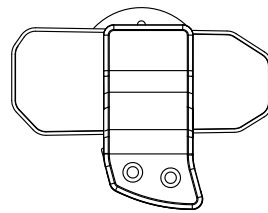

Clip*1

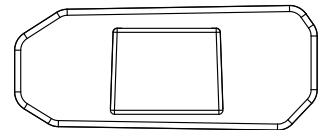

Double-Sided
Adhesive Clip*1

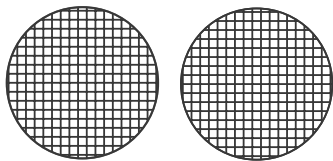

Speaker Self-Adhesive
Tape*2

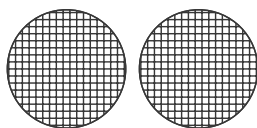

Microphone Self-
Adhesive Tape*2

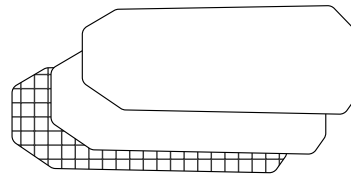

Clip Self-Adhesive
Tape*3

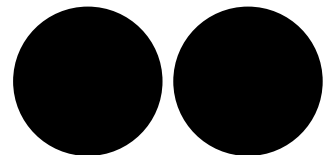

Heightening
Pad*2

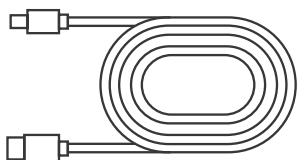

Data Cable*1



User Manual*1



TF Card*1

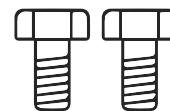

Screws*2

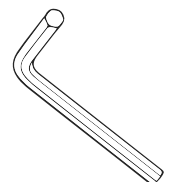

Installation Wrench*1

• Note

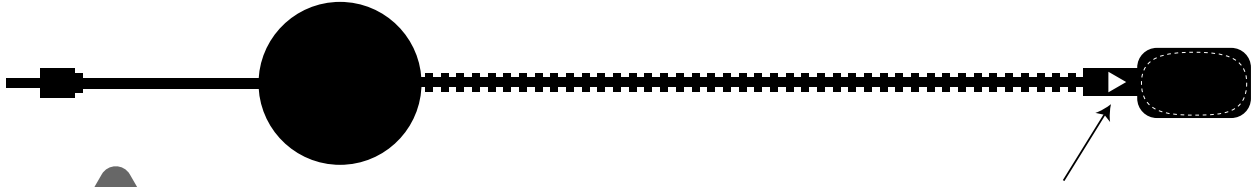

To experience high-quality call effects, after installing the hard microphone, please ensure that the < ▶ > symbol is aligned with the direction of your mouth; otherwise, there may be noise during the call.



Reset Operation: If you encounter issues such as unresponsive buttons, please press and hold the power button for 16 seconds. The red light will flash for 1 second to indicate shutdown. You can then turn it back on to eliminate any anomalies.



(APP Download)

Manuel d'Utilisation

Présentation du Produit

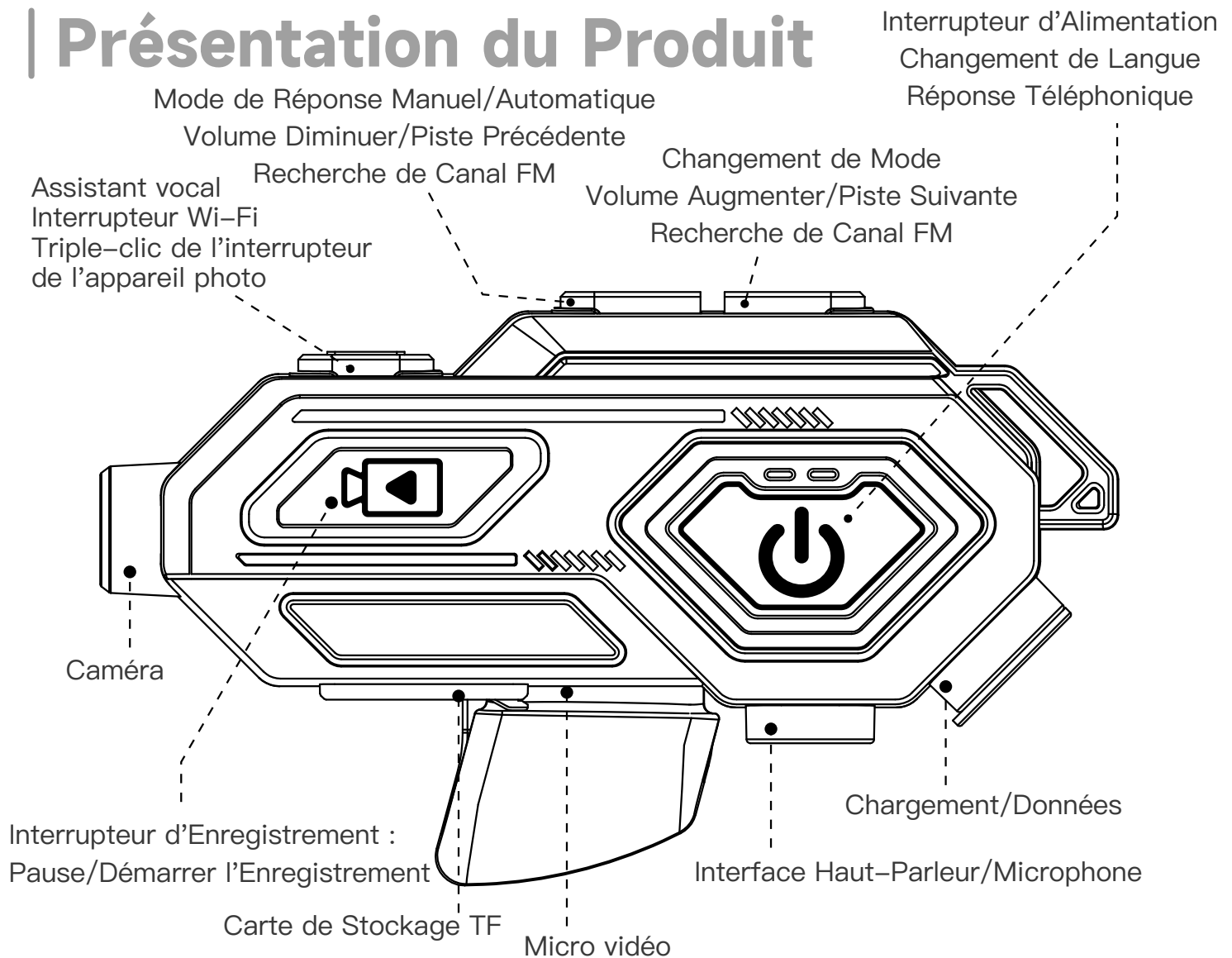

Remarque Importante ::

1. Testez le volume et vérifiez la carte TF avant d'installer les écouteurs.
2. Ajustez la position du haut-parleur si le volume diffère après installation.
Chargez si l'avertissement de batterie faible se déclenche.
3. La consommation d'énergie élevée est normale ; la fonction Bluetooth peut être disponible après l'arrêt pour batterie faible.

• Fonctions du Téléphone

Double-tapez Volume (-)

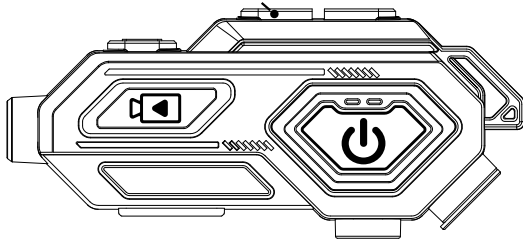

→
(Lors de la connexion Bluetooth)

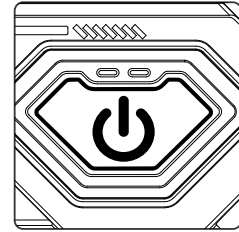

Changer en mode manuel/automatique

Changement de mode lorsque non connecté au téléphone

Mode Automatique (réponse automatique après 10 secondes)

Pendant un appel, double-tapez sur le bouton d'alimentation pour passer entre téléphone et appareil



(Appel Entrant)
(⊖ Après 10 secondes)



Automatique

Réponse
Automatique



(Appel Entrant)



Réponse Manuelle
pour Appel Entrant

Répondre



(Appel Entrant)



Maintenir 2
secondes

Rejeter l'Appel



(En cours d'appel)



"Appui court"
Pendant l'Appel

Terminer l'Appel



Double-tap

Rappel du Dernier
Numéro



(Pendant que
l'appel continue)



Appui court

Annuler l'Appel
en Cours

• Puissance On/Off

► Allumer/Éteindre l'alimentation

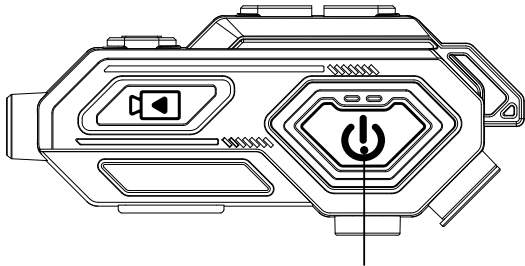

Appuyer longuement pendant
3 secondes pour allumer l'appareil

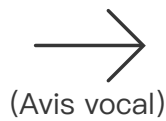

(Avis vocal)

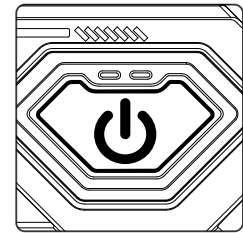

Lampe LED allumée

• Appairer le téléphone et les écouteurs

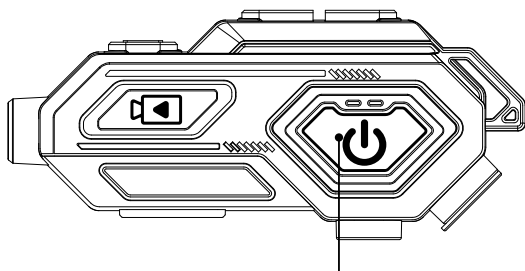

Bluetooth non connecté,
LED clignotante

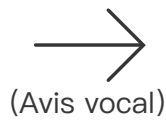

(Avis vocal)

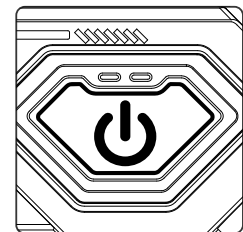

Bluetooth connecté, LED clignotante
par intermittence

• Mode de Chargement

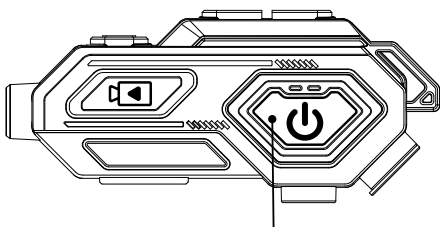

Lampe indicatrice allumée
pendant la charge

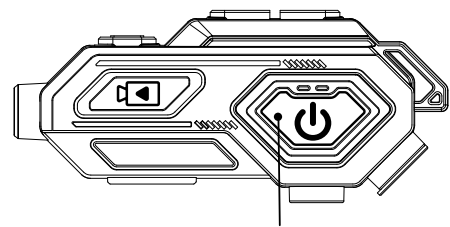

La lampe indicatrice s'éteint lorsque
la charge est complète

(Lorsque l'appareil est allumé, brancher le chargeur éteindra automatiquement l'appareil)

• Fonction Musique

► Pause/Reprendre la Musique



Appui Court

→
(Musique Arrêtée)



Paussée

→
(Musique en
Cours de Lecture)



Jouer

Bouton Volume Bas

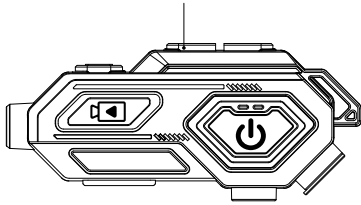

Appui Court pour
Piste Précédente

→
(Musique en
Cours de Lecture)



Appui Long pour
Diminuer le Volume

Bouton Volume Haut

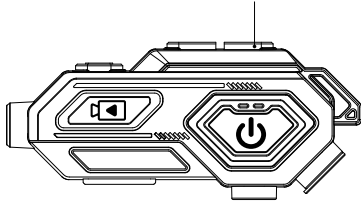

Appui Court pour
Piste Suivante

→
(Musique en
Cours de Lecture)



Appui Long pour
Augmenter le Volume

• Assistant Vocal

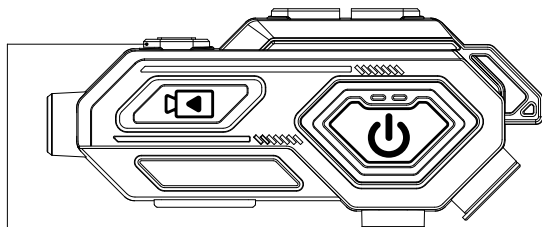

Bouton Assistant Vocal

→
Appui Court



Éveiller l'Assistant Vocal

● Pairage de partage de musique

- Double-cliquez sur le bouton WiFi des appareils A/B, et les appareils A/B entreront en mode de partage de musique, avec le voyant LED coloré du bouton d'alimentation clignotant rapidement
- Une fois les appareils A/B appariés avec succès, le voyant LED coloré du bouton d'alimentation clignotera par intermittence.

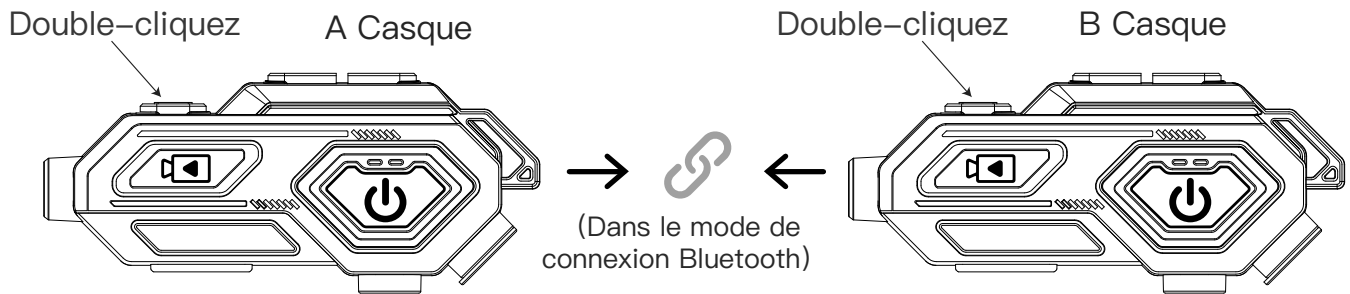

Remarque:

1. En mode de partage de musique, si les appareils A et B sont déconnectés, le voyant d'alimentation clignotera rapidement pour alerter
2. En mode de partage de musique, les boutons de volume +/-, et de lecture des appareils A et B peuvent contrôler le téléphone

● Pairage de talkie On/Off

- Double-cliquez sur le bouton de volume "+" des appareils A/B, et les appareils A/B entreront en mode de partage de talkie, avec le voyant LED vert du bouton d'alimentation clignotant rapidement
- Une fois les appareils A/B appariés avec succès, le voyant LED vert du bouton d'alimentation clignotera par intermittence.

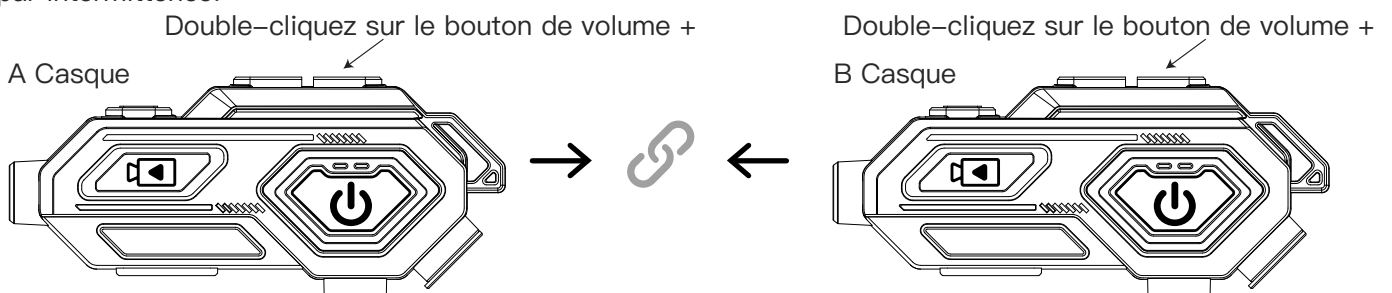

Remarque:

1. En mode talkie, si les appareils A et B sont déconnectés, le voyant d'alimentation vert clignotera rapidement pour alerter
2. Si les appareils A et B rencontrent des décalages ou des interruptions, ils se reconnecteront automatiquement lorsqu'ils seront rapprochés
3. Lors du passage au mode talkie, la connexion Bluetooth du téléphone sera automatiquement déconnectée; lors du retour en mode Bluetooth, les écouteurs se reconnecteront automatiquement au téléphone

● Mode FM

- Double-cliquez sur le bouton de volume “+” pour entrer en mode FM, le voyant LED orange du bouton d’alimentation clignote de manière intermittente.
- Appuyez brièvement sur les boutons de volume +/- pour que l’appareil entre en mode de recherche semi-automatique, en suspendant la recherche lorsqu’un signal radio clair est trouvé, effectuant une recherche séquentielle des stations (le câble du haut-parleur doit être branché pendant la recherche).

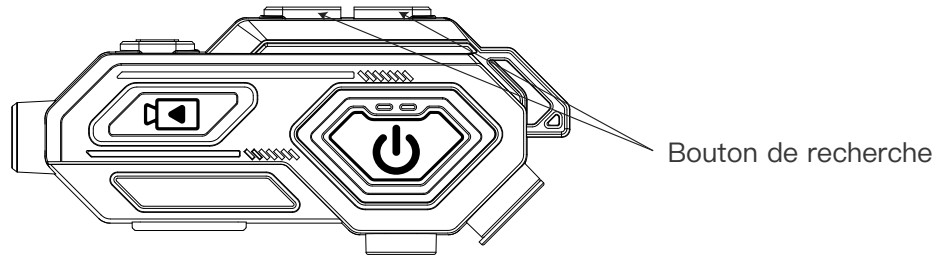

Remarque:

1. En mode FM, si vous ne souhaitez pas écouter la radio, vous pouvez appuyer sur le bouton d’alimentation pour activer le mode silencieux; appuyer à nouveau sur le bouton d’alimentation ramènera le son.
2. Selon l’environnement, il peut parfois y avoir un bruit de “fouillis”; veuillez essayer de l’utiliser à l’extérieur ou dans des zones dégagées.

● Fonction d'enregistrement (Dashcam)

- Appuyez longuement sur l’interrupteur d’enregistrement pendant 5 secondes pour allumer/éteindre; l’enregistrement commencera automatiquement après l’allumage.
- Appuyez brièvement sur le bouton d’enregistrement pour mettre en pause/démarrer l’enregistrement.

Le LED vert clignote à l’allumage, et clignote lentement pendant l’enregistrement.

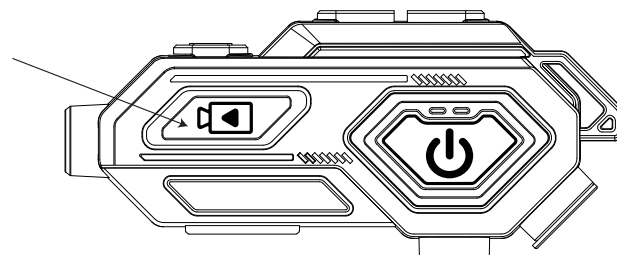

≤256G/C10

Remarque:

1. Les fichiers vidéo sur la carte de stockage TF sont stockés en segments de 2 minutes (la durée peut être réglée via l’application).
2. Le dashcam a une consommation électrique élevée; lorsque la batterie est faible, il s’éteindra immédiatement après l’allumage. La fonction Bluetooth (à faible consommation d’énergie) peut continuer à être utilisée après l’arrêt automatique, ce qui est normal.)
3. Certaines cartes TF avec certaines vitesses peuvent ne pas être compatibles avec cet appareil; il prend en charge une capacité maximale de 256G avec une vitesse d’écriture de C10; les cartes inférieures à C10 ne sont pas prises en charge.
4. Si le système détecte qu’aucune carte TF n’est insérée après l’allumage, l’appareil s’éteindra automatiquement après 3 minutes.
5. Le système du dashcam a une consommation électrique élevée; il peut légèrement chauffer après une longue utilisation. L’appareil dispose d’une fonction de détection de la température, donc utilisez-le en toute confiance.

• Fonction Wifi (Hotspot)

- Appuyez longuement sur l'interrupteur Wi-Fi pendant 5 secondes pour l'allumer/éteindre. Après l'allumage, le téléphone n'est pas connecté au point d'accès de secours. Il s'éteindra automatiquement après 5 minutes.

Le LED orange clignote à l'allumage et clignote lentement après connexion au téléphone.

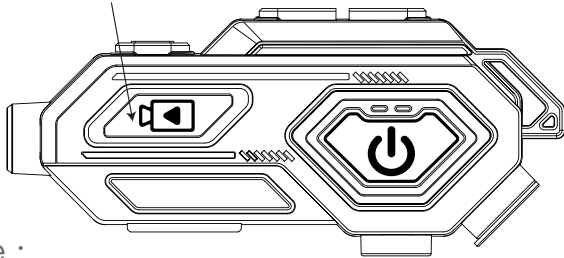

APP



APP

Note :

1. Ouvrez un appareil Android ou iOS et recherchez l'application "Roadcam/GoPlus cam" dans le marché des applications ou l'App Store pour télécharger et installer, ou scannez le code QR sur WeChat pour télécharger; et autorisez l'accès aux services d'information et à la caméra. 2. Les chemins de recherche peuvent varier légèrement selon le dispositif; veuillez suivre les instructions sur l'interface utilisateur du téléphone pour l'installation. 3. Pendant le processus de connexion de l'application du dispositif au téléphone, aucune autre connexion à des hotspots WiFi n'est possible. 4. Mot de passe du hotspot WiFi : 12345678 (modifiable dans l'application).

• Fonction Wifi+APP (Hotspot) Installation et Utilisation

- Maintenez la touche WiFi enfoncée pendant 5 secondes pour l'allumer/l'éteindre. Après la mise sous tension, le LED orange clignote rapidement. (La fonction d'enregistrement doit être activée avant d'activer le Wi-Fi.)

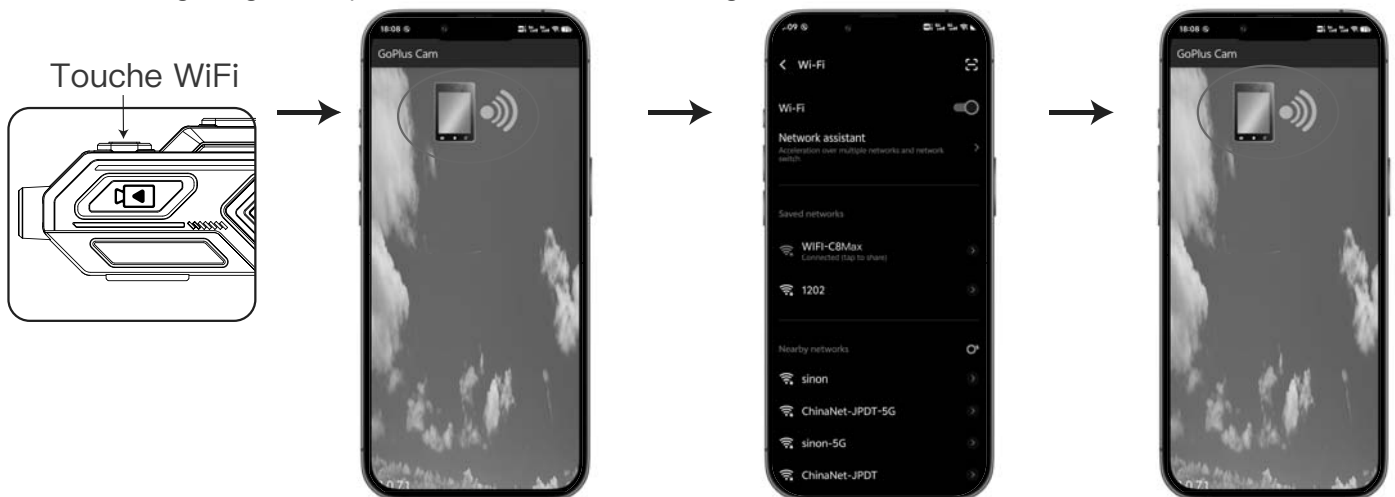

Cliquez sur l'application téléchargée pour accéder à cette page, cliquez sur l'icône de connexion et elle passera automatiquement à l'interface Wi-Fi.

Accédez à cette page, cliquez sur C8-Max et saisissez le mot de passe initial : 12345678 pour réussir la connexion.

Retournez à la page d'accueil de l'application et cliquez sur l'icône pour entrer.

Remarque:

1. Pour revenir à l'interface principale de l'APP, faites glisser vers le haut depuis le coin inférieur droit de l'écran du téléphone.
2. Le contenu de la carte de stockage peut être copié et supprimé en connectant à un ordinateur via un câble USB.
3. La fonctionnalité Gsonser et la sensibilité peuvent être activées ou désactivées dans l'APP.)

Cliquez sur l'icône de fichier en haut à gauche pour voir les vidéos enregistrées et les images stockées.

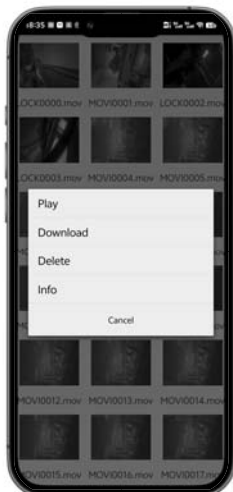

Cliquez sur l'icône des paramètres en haut à droite pour accéder à divers réglages.

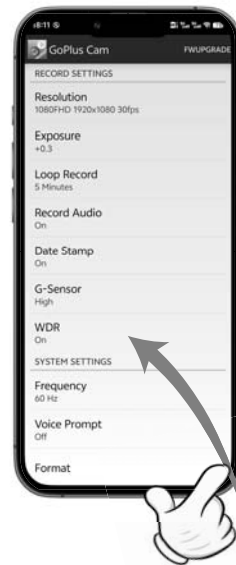

Pour revenir à l'interface principale de l'APP, faites glisser vers le haut depuis le coin inférieur droit de l'écran du téléphone.

Interface de caméra



Déconnexion

Pause/Continuer

Cliquez sur l'icône en bas à droite pour passer du mode d'enregistrement vidéo au mode photo.

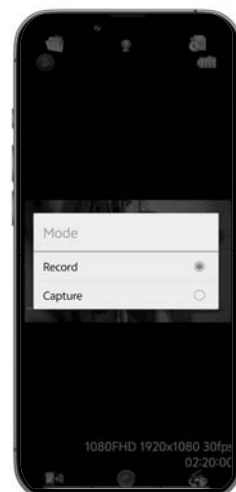

• USB Mode

- Le produit peut être utilisé pour se connecter à un ordinateur afin de copier et de supprimer des vidéos et des photos

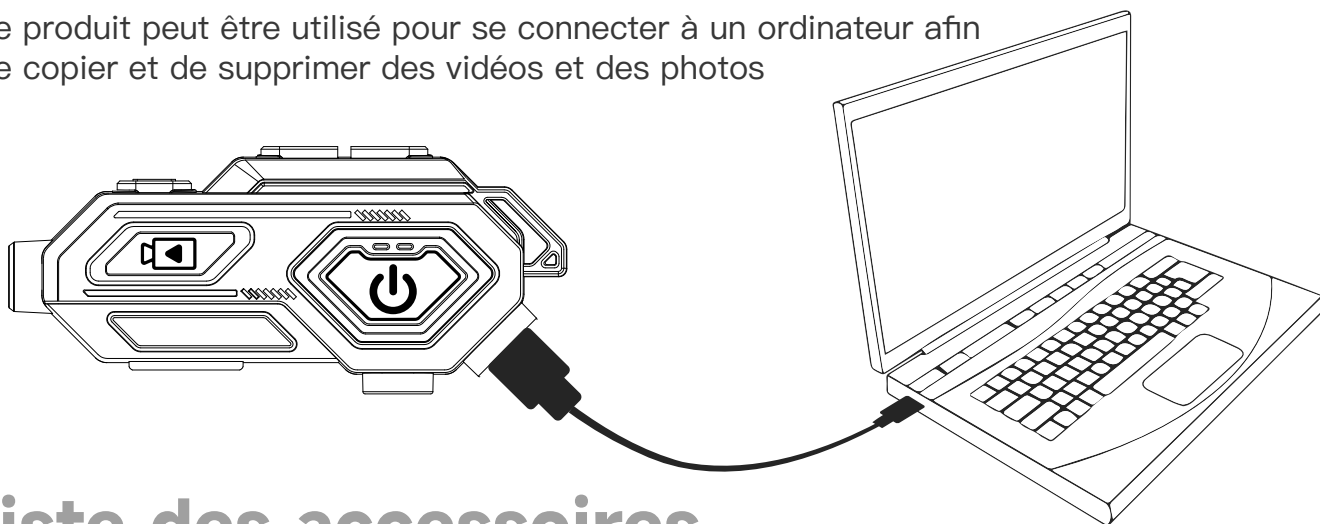

• Liste des accessoires

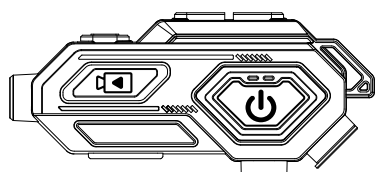

C8Max*1

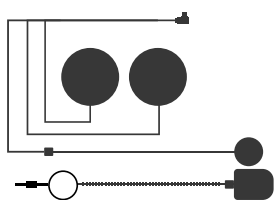

Casque et
Microphone*1

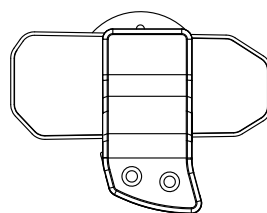

Clip*1

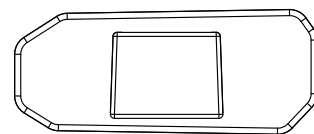

Clip adhésif double
face*1

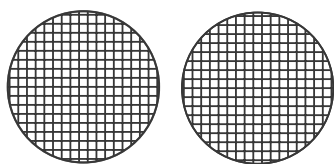

Ruban adhésif pour
haut-parleur*2

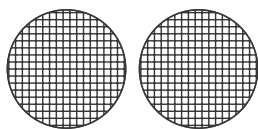

Ruban adhésif pour
microphone*2

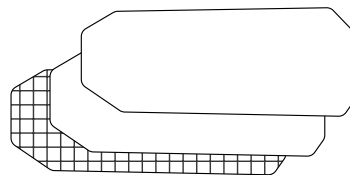

Ruban adhésif
pour clip*3

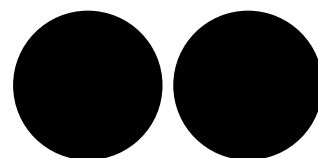

Coussin de
rehausse*2

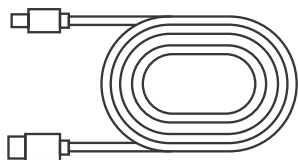

Câble de données*1

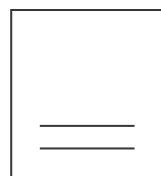

Manuel
d'utilisation*1



Carte TF*1

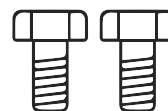

Vis*2

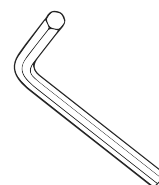

Clé d'installation*1

• Note

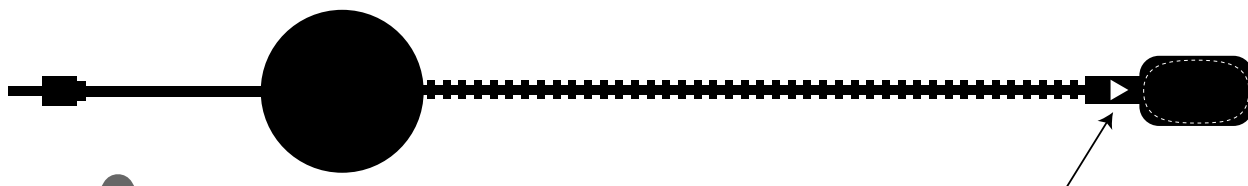

Pour bénéficier d'une qualité d'appel optimale, après l'installation du microphone dur, veuillez vous assurer que le symbole < ► > est orienté vers votre bouche ; sinon, il peut y avoir des bruits pendant l'appel.



Opération de réinitialisation : Si vous rencontrez des problèmes tels que des boutons non réactifs, veuillez appuyer et maintenir le bouton d'alimentation pendant 16 secondes. Le voyant rouge clignotera pendant 1 seconde pour indiquer l'arrêt. Vous pourrez ensuite le rallumer pour éliminer toute anomalie.



(Téléchargement de l'APP)

Benutzerhandbuch

Produktübersicht

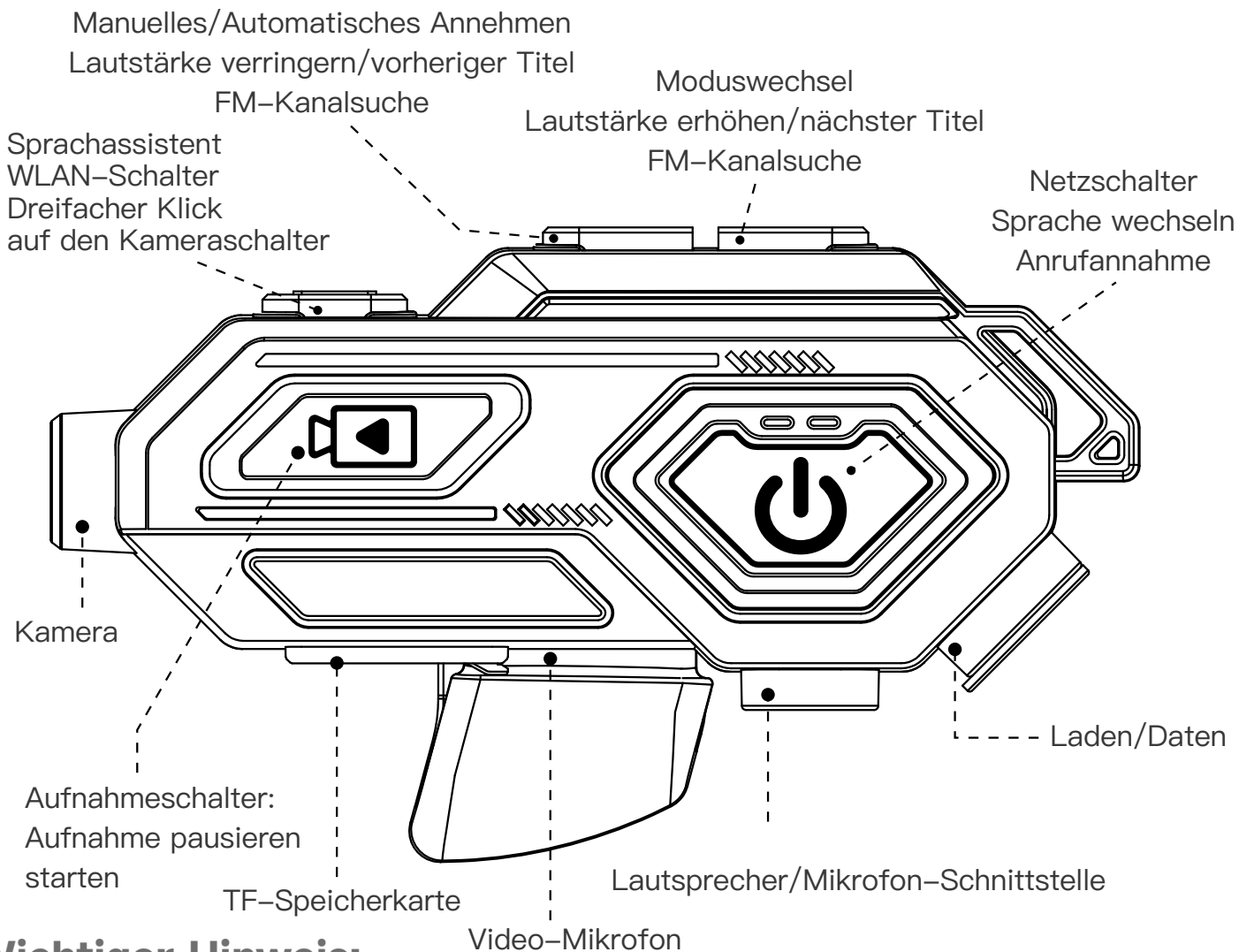

Wichtiger Hinweis:

1. Verbinden Sie das Telefon, um den Volume zu testen und die TF-Karte zu überprüfen.
2. Passen Sie die Lautsprecherposition an, wenn das Volumen unterschiedlich ist.
Laden Sie bei niedrigem Batteriestand.
3. Hoher Stromverbrauch ist normal; die Bluetooth-Funktion kann nach dem Herunterfahren verfügbar sein.

• Telefonfunktionen

Doppeltippen Volume (-)

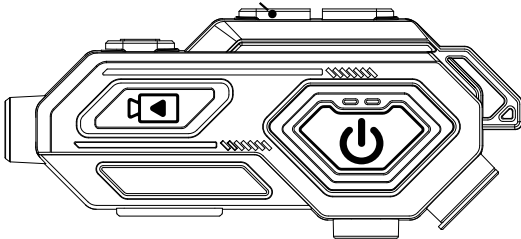

→
(Beim Verbinden mit Bluetooth)

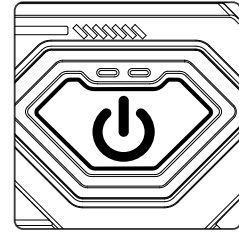

Umschalten auf manuellen automatischen Anrufmodus

Ändern des Modus, wenn nicht mit dem Telefon verbunden
Automatischer Modus (automatische Antwort nach 10 Sekunden)

Während eines Anrufs doppeltippen auf die
Einschalttaste, um zwischen Telefon und
Gerät zu wechseln



(Eingehender Anruf)
(Nach 10 Sekunden)

Automatisch

Automatische
Antwort



(Eingehender
Anruf)

Manuelle Antwort für
Eingehenden Anruf

Annehmen



(Eingehender
Anruf)

2 Sekunden
gedrückt halten

Anruf
Ablehnen



(Aktuell im
Anruf)

"Kurzer Druck"
Während des Anrufs

Anruf
Beenden



Doppeltippen

Letzte Nummer
Wahlwiederholung



(Während des
Anrufs fortsetzen)

Kurzer Druck

Aktuellen Anruf
abbrechen

• Strom ein-/auszuschalten

▶ Strom ein-/auszuschalten

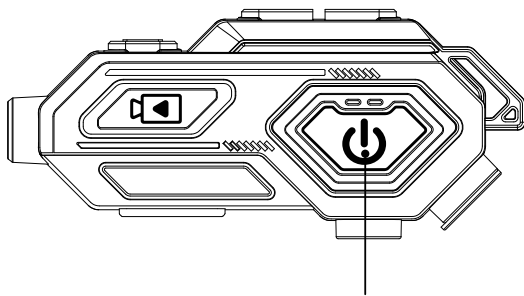

Lang drücken für 3 Sekunden,
um das Gerät einzuschalten

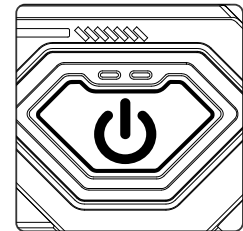

LED-Leuchte an

• Telefon und Kopfhörer koppeln

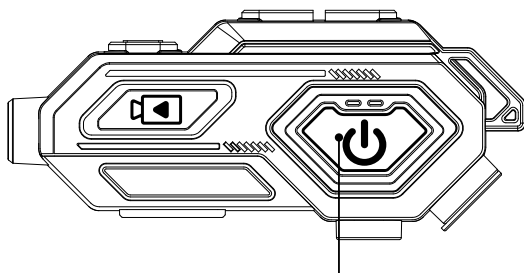

Bluetooth nicht
verbunden, LED blinkt

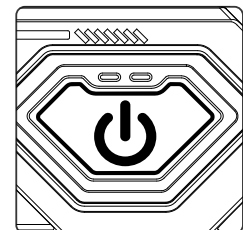

Bluetooth verbunden, LED
blinkt intermittierend

• Lademodus

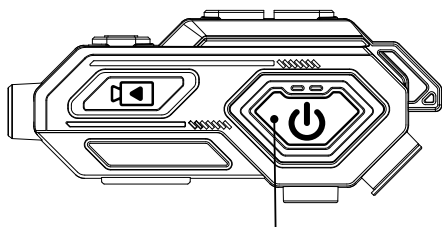

Anzeigeleuchte leuchtet
während des Ladevorgangs

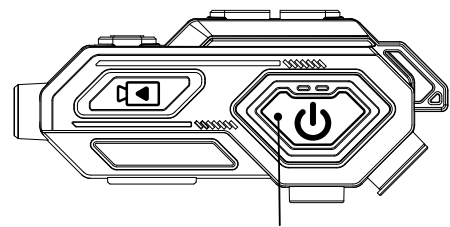

Anzeigeleuchte erlischt, wenn der
Akku vollständig geladen ist

(Wenn das Gerät eingeschaltet ist, schaltet das Einstecken des Ladegeräts das Gerät automatisch aus)

• Musikfunktion

▶ Musik pausieren/Abspielen



Kurzer Druck



Pause



Spielen

Lautstärke verringern Taste

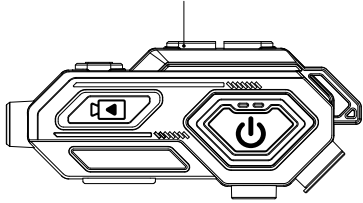

Kurzer Druck auf den vorherigen Titel

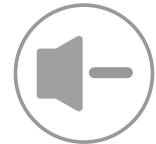

Langer Druck zur Lautstärkereduzierung

Lautstärke erhöhen Taste

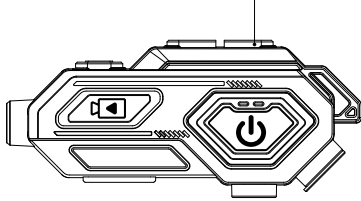

Kurzer Druck auf den nächsten Titel



Langer Druck zur Lautstärkeerhöhung

• Sprachassistent

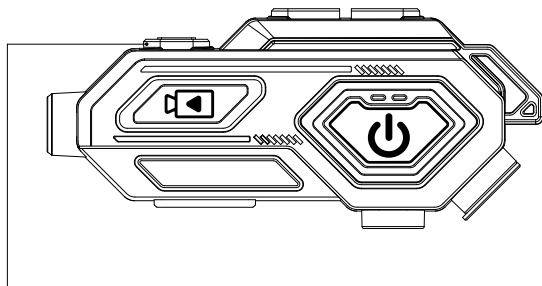

Taste für Sprachassistent

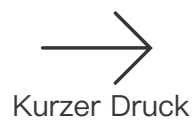

Sprachassistent aktivieren

• Musiksharing-Paarung

- Doppelklicken Sie auf die WiFi-Taste der Geräte A/B, um in den Musiksharing-Paarungsmodus zu gelangen; die farbige LED-Anzeige des Netzschalters blinkt schnell.
- Sobald die Geräte A/B erfolgreich gekoppelt sind, blinkt die farbige LED-Anzeige des Netzschalters intermittierend.

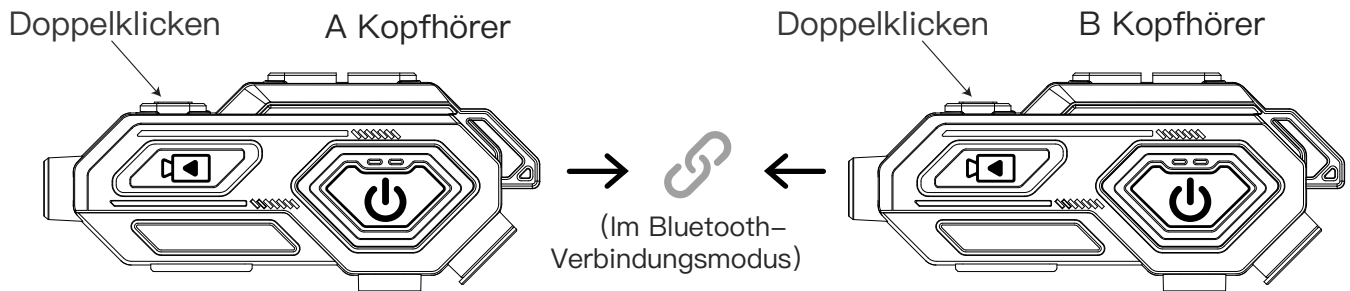

Hinweis:

1. Im Musiksharing-Modus blinkt die LED-Anzeige des Netzschalters schnell, um bei der Trennung der Geräte A und B zu warnen.
2. Im Musiksharing-Modus können die Lautstärketasten +/–, sowie die Wiedergabetaste der Geräte A und B das Telefon steuern.

• Gegensprechanlagen-Paarung Ein/Aus

- Doppelklicken Sie auf die Lautstärketaste "+" der Geräte A/B, um in den Gegensprechanlagen-Paarungsmodus zu gelangen; die grüne LED-Anzeige des Netzschalters blinkt schnell.
- Nach erfolgreicher Kopplung der Geräte A/B blinkt die grüne LED-Anzeige des Netzschalters intermittierend.

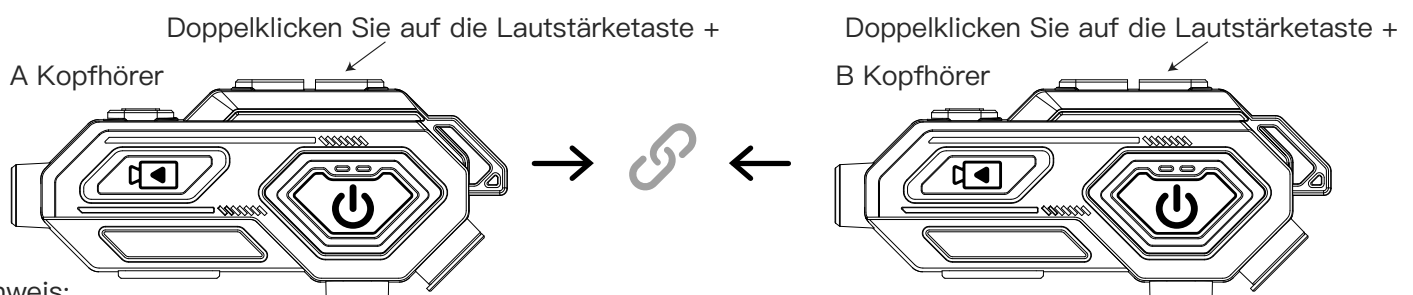

Hinweis:

1. Im Gegensprechanlagenmodus blinkt die grüne Anzeige des Netzschalters schnell, um bei der Trennung der Geräte A und B zu warnen.
2. Wenn die Geräte A und B Verzögerungen oder Unterbrechungen aufweisen, werden sie sich automatisch wieder verbinden, wenn sie näher gebracht werden.
3. Beim Wechsel in den Gegensprechanlagenmodus wird die Bluetooth-Verbindung des Telefons automatisch getrennt; beim Zurückwechseln in den Bluetooth-Modus stellen die Kopfhörer automatisch die Verbindung zum Telefon wieder her.

• FM-Modus

- Doppelklicken Sie auf die “+” Lautstärketaste, um in den FM-Modus zu wechseln, die orange LED-Anzeige des Netzschalters blinkt intermittierend.
- Drücken Sie kurz auf die Tasten zur Lautstärkeregelung, um in den halbautomatischen Suchmodus zu wechseln. Wenn ein klarer Radiosender gefunden wird, pausiert die Suche und es wird nacheinander nach Sendern gesucht (bitte stellen Sie sicher, dass das Lautsprecherkabel während der Suche angeschlossen ist).

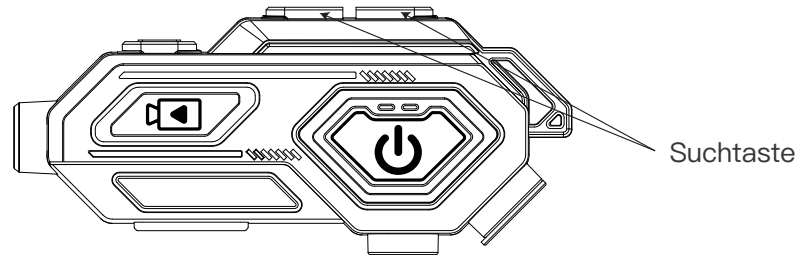

Hinweis:

1. Im FM-Modus können Sie die Einschalttaste drücken, um den Ton stummzuschalten, und durch einen weiteren Druck auf die Einschalttaste wird der Ton wiederhergestellt.
2. Je nach Umgebung kann es manchmal zu "Rauschgeräuschen" kommen; bitte versuchen Sie, das Gerät im Freien oder in offenen Bereichen zu verwenden.

• Aufzeichnungsfunktion (Dashcam)

- Halten Sie den Aufnahme-Schalter 5 Sekunden lang gedrückt, um ihn ein-/auszuschalten; nach dem Einschalten beginnt die Aufnahme automatisch.
- Kurz drücken Sie die Aufnahmetaste, um die Aufnahme zu pausieren/zu starten.

Die grüne LED blinkt beim Einschalten und blinkt langsam während der Aufnahme.

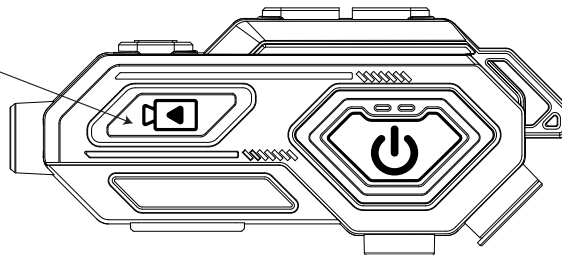

≤256G/C10

Hinweis:

1. Die Video-Dateien auf der TF-Speicherkarte werden in Segmenten von 2 Minuten gespeichert (die Länge kann über die App eingestellt werden).
2. Der Dashcam hat einen hohen Stromverbrauch; wenn der Akku niedrig ist, schaltet er sich sofort nach dem Einschalten aus. Die Bluetooth-Funktion (die einen niedrigen Stromverbrauch hat) kann nach der automatischen Abschaltung weiter verwendet werden, was normal ist.
3. Einige TF-Karten mit bestimmten Geschwindigkeiten sind möglicherweise nicht mit diesem Gerät kompatibel; die maximale unterstützte Kapazität beträgt 256G mit einer Schreibgeschwindigkeit von C10; Karten unter C10 werden nicht unterstützt.
4. Wenn das System nach dem Einschalten keine TF-Karte erkennt, schaltet sich das Gerät nach 3 Minuten automatisch aus.
5. Das System des Dashcams hat einen hohen Stromverbrauch; es kann nach längerer Benutzung leicht warm werden. Das Gerät verfügt über eine Temperaturüberwachungsfunktion, sodass Sie es mit Vertrauen verwenden können.

• Wifi-Funktion (Hotspot)

- Drücken und halten Sie den Wi-Fi-Schalter 5 Sekunden lang, um ihn ein-/auszuschalten. Nach dem Einschalten ist das Telefon nicht mit dem Backup-Hotspot verbunden. Es wird nach 5 Minuten automatisch ausgeschaltet.

Die orangefarbene LED blinkt beim Einschalten und blinkt langsam, wenn das Telefon verbunden ist.

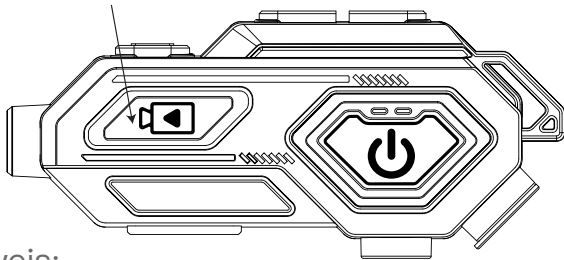

APP



APP

Hinweis:

1. Öffnen Sie ein Android- oder iOS-Gerät und suchen Sie im App Store nach der APP „Roadcam/GoPlus cam“ zum Herunterladen und Installieren, oder scannen Sie den QR-Code in WeChat, um herunterzuladen; erlauben Sie den Zugriff auf Informationsdienste und die Kamera.
2. Die Suchpfade können je nach Gerät leicht variieren; bitte folgen Sie den Anweisungen auf dem Benutzerhandy zur Installation.
3. Während der Verbindung des Handys mit der Geräte-App darf keine andere WiFi-Hotspot-Verbindung hergestellt werden.
4. WiFi-Hotspot-Passwort: 12345678 (kann in der App geändert werden).

• Wifi+APP-Funktion (Hotspot) Installation und Nutzung

- Halten Sie die WiFi-Taste 5 Sekunden lang gedrückt, um sie ein-/auszuschalten. Nach dem Einschalten blinkt die orangefarbene LED schnell. (Die Aufnahmefunktion muss aktiviert werden, bevor das WLAN eingeschaltet wird.)

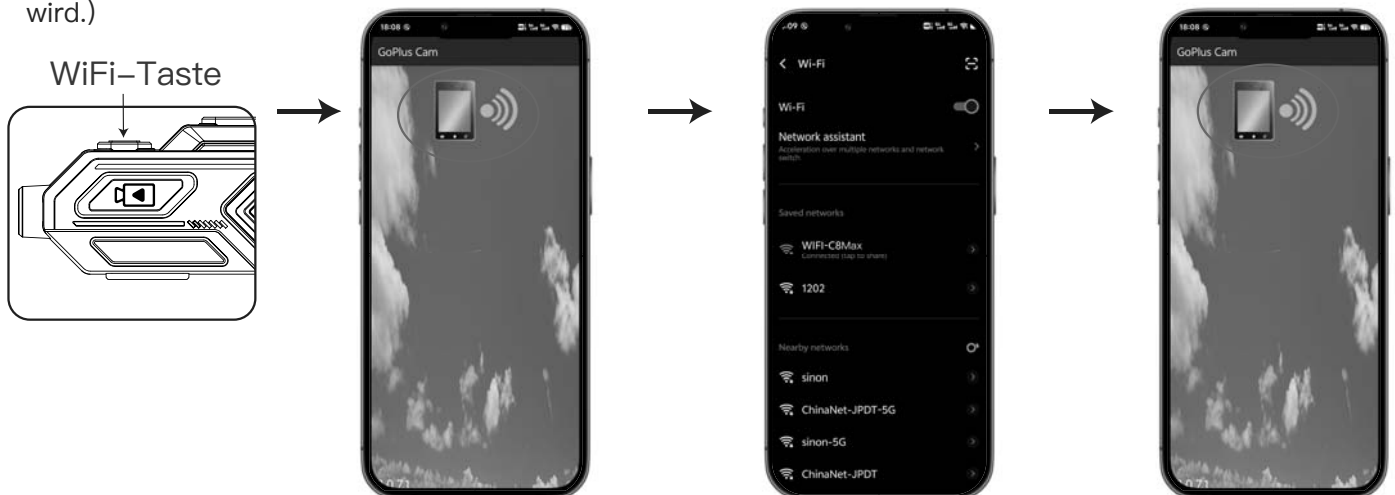

Klicken Sie auf die heruntergeladene APP, um diese Seite zu öffnen. Klicken Sie auf das Verbindungssymbol, um automatisch zur Wi-Fi-Oberfläche zu wechseln.

Betreten Sie diese Seite, klicken Sie auf C8-Max und geben Sie das anfängliche Passwort ein: 12345678, dann ist die Verbindung erfolgreich.

Gehen Sie zurück zur APP-Startseite und klicken Sie auf das Symbol, um fortzufahren.

Hinweis:

1. Um zum Hauptbedienungsbildschirm der APP zurückzukehren, wischen Sie von der unteren rechten Ecke des Telefonbildschirms nach oben.
2. Inhalte auf der Speicherkarte können durch Anschließen an einen Computer über ein USB-Datenkabel kopiert und gelöscht werden.
3. Die Gsonser-Funktionalität und die Empfindlichkeit können in der APP ein- oder ausgeschaltet werden.

Klicken Sie auf das Datei-Symbol in der oberen linken Ecke, um aufgezeichnete Videos und gespeicherte Bilder anzusehen.

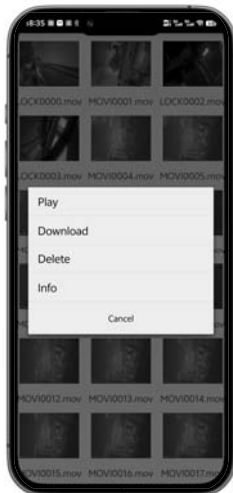

Klicken Sie auf das Einstellungssymbol in der oberen rechten Ecke, um auf verschiedene Regelungen zuzugreifen.

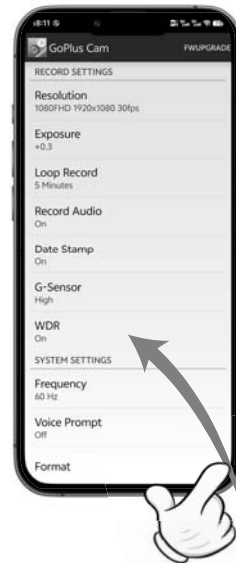

Um zum Hauptbedienungsbildschirm der APP zurückzukehren, wischen Sie von der unteren rechten Ecke des Telefonbildschirms nach oben.

Kameraoberfläche



Trennen

Pause/Fortsetzen

Klicken Sie auf das Symbol in der unteren rechten Ecke, um zwischen Videoaufnahme- und Fotomodus zu wechseln.

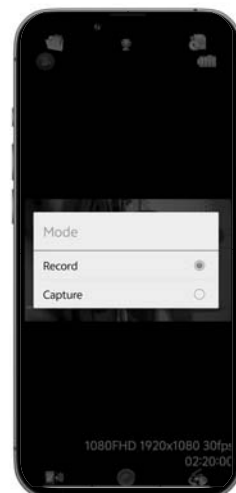

• USB-Modus

- Das Produkt kann verwendet werden, um sich mit einem Computer zu verbinden, um Videos und Fotos zu kopieren und zu löschen

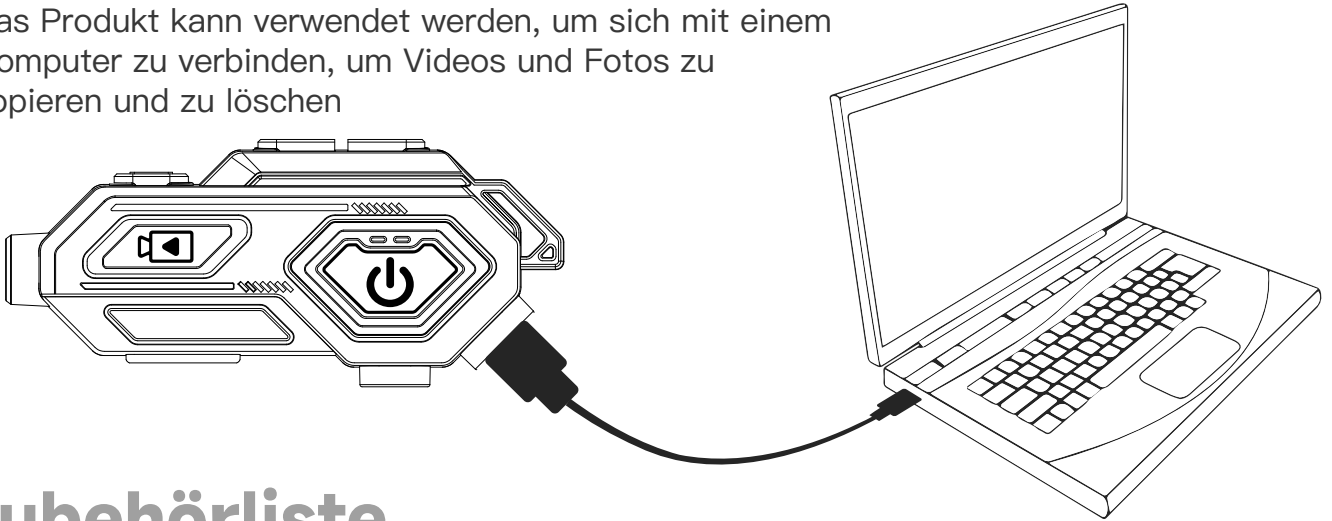

• Zubehörliste

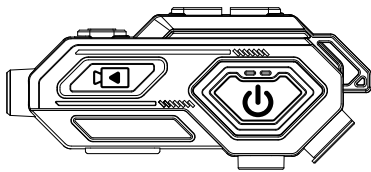

C8Max*1

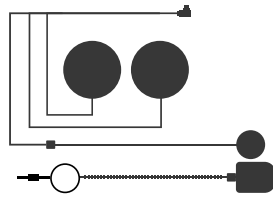

Kopfhörer und
Mikrofon*1

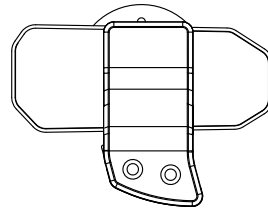

Clip*1

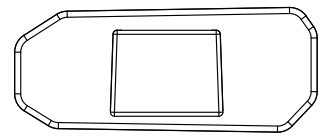

Doppelseitiger
Klebe-Clip*1

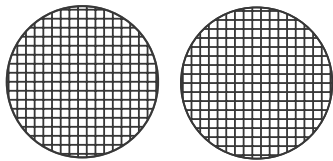

Lautsprecher
selbstklebendes Band*2

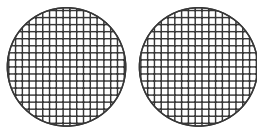

Mikrofon selbstklebendes
Band*2

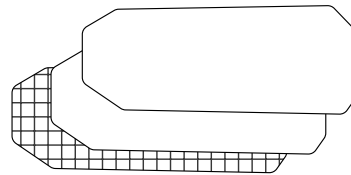

Clip selbstklebendes
Band*3

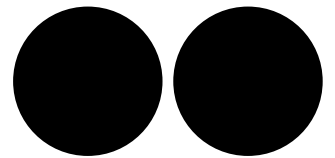

Erhöhungspolster*2

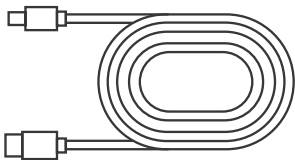

Datenkabel*1

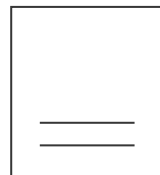

Benutzerhandbuch*1



TF-Karte*1

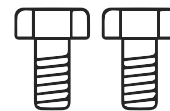

Schrauben*2

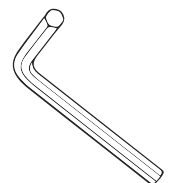

Installationsschlüssel*1

• Note

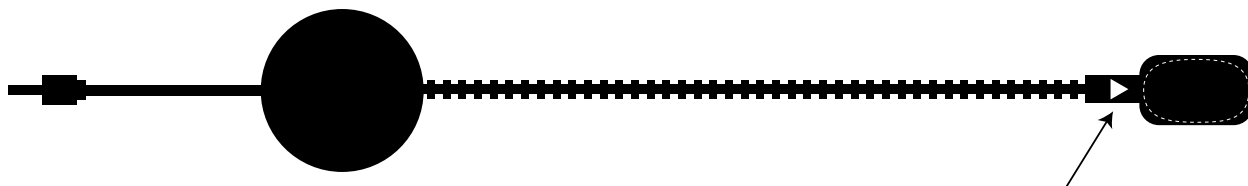

Um eine hochwertige Gesprächsqualität zu erleben, stellen Sie bitte sicher, dass das < ► > Symbol nach der Installation des harten Mikrofons in Richtung Ihres Mundes zeigt; andernfalls kann es während des Gesprächs zu Störgeräuschen kommen.



Reset-Vorgang: Wenn Sie Probleme wie nicht reagierende Tasten feststellen, halten Sie bitte die Einschalttaste 16 Sekunden lang gedrückt. Die rote Lampe blinkt 1 Sekunde lang, um das Ausschalten anzuzeigen. Sie können das Gerät dann wieder einschalten, um Anomalien zu beseitigen.



(APP-Download)

Manuale Utente

Panoramica del Prodotto

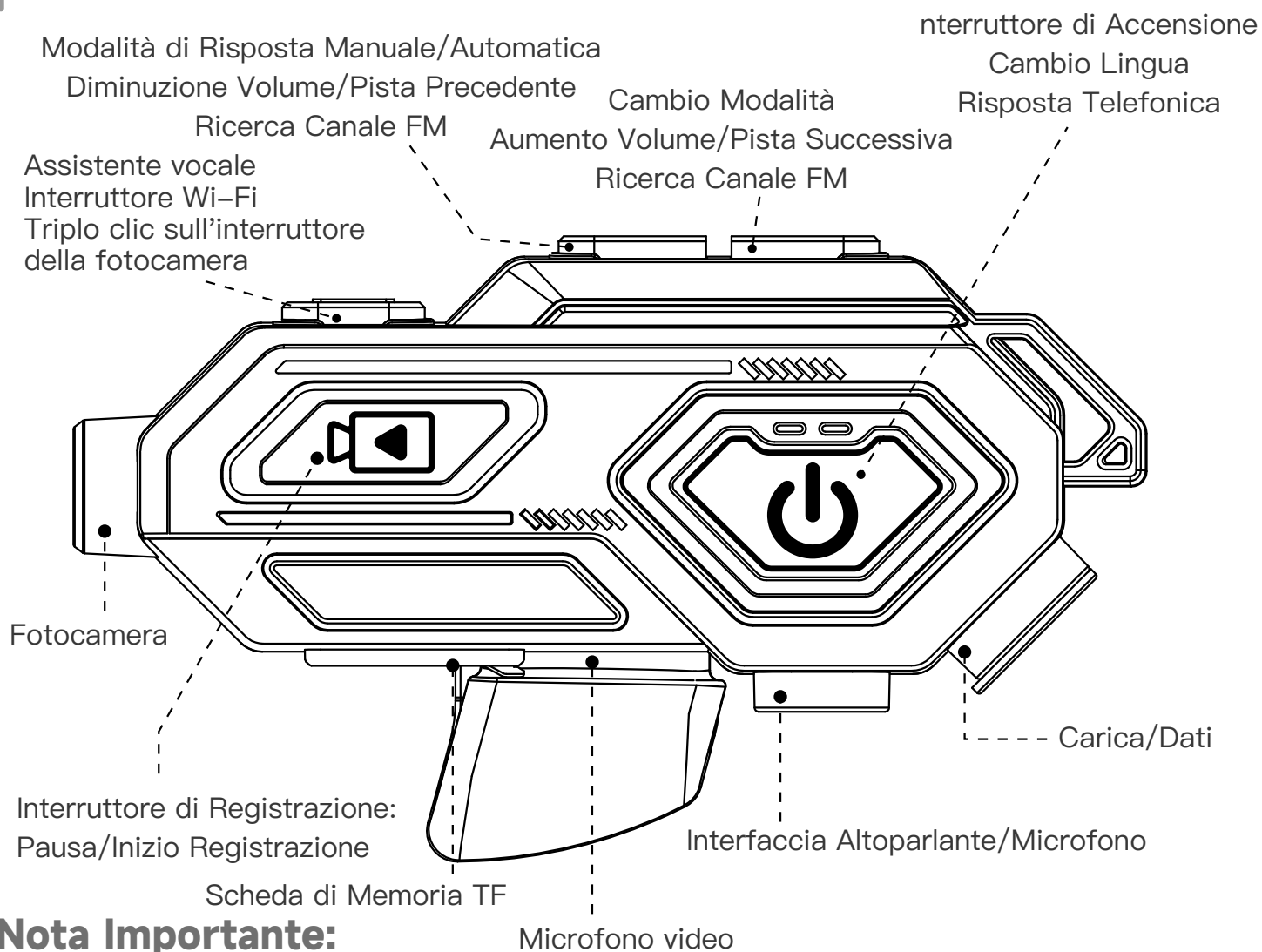

Nota Importante:

1. Collega il telefono per testare il volume e controllare la scheda TF prima di installare le cuffie.
2. Regola la posizione dell'altoparlante se il volume differisce dopo l'installazione.
 Carica il dispositivo se senti un avviso di batteria bassa.
3. Un alto consumo energetico è normale; la funzione Bluetooth può essere disponibile dopo lo spegnimento per batteria scarica.

• Funzioni del Telefono

Doppio tocco Volume (-)

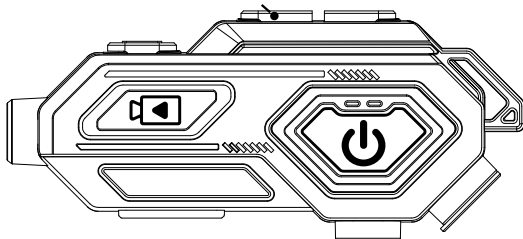

→
(Quando connesso a Bluetooth)

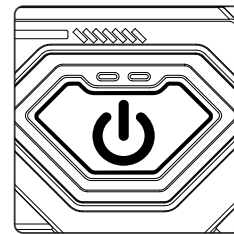

Passare a modalità manuale/automatica

Cambiare modalità quando non è connesso al telefono
Modalità Automatica (risposta automatica dopo 10 secondi)

Durante una chiamata, doppio tocco sul pulsante di accensione per passare tra telefono e dispositivo



(Chiamata in Arrivo)
(Dopo 10 secondi)



Automatico

Risposta Automatica



(Chiamata in Arrivo)



Risposta Manuale per Chiamata in Arrivo

Rispondere



(Chiamata in Arrivo)



Tenere premuto 2 secondi

Rifutare la Chiamata



(Attualmente in chiamata)



"Premere Brevemente" Durante la Chiamata

Terminare la Chiamata



Doppio tocco

Ricomponi Ultimo Numero



(Mentre la chiamata continua)



Premere Brevemente

Annulla Chiamata Corrente

• Accensione/Spegnimento

▶ Accendere/Spegnere l'alimentazione

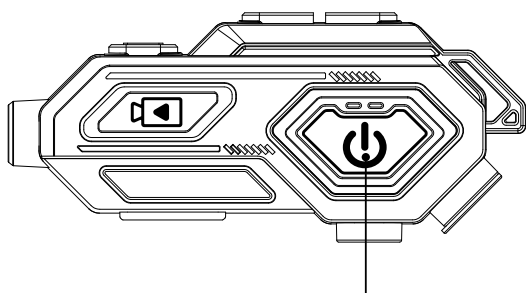

Tenere premuto per 3 secondi
per accendere il dispositivo

→
(Aviso vocale)

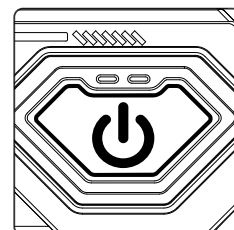

Luce LED accesa

• Appaiare il telefono e le cuffie

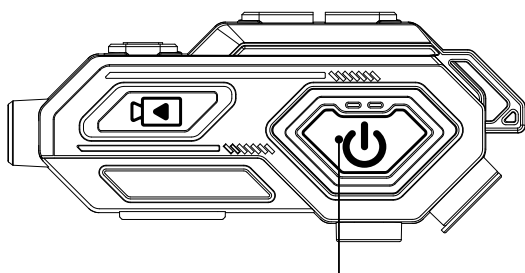

Bluetooth non connesso, LED lampeggiante

→
(Aviso vocale)

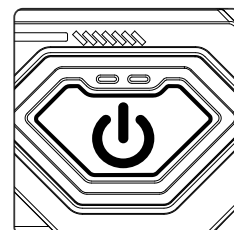

Bluetooth connesso, LED lampeggiante
a intermittenza

• Modalità di Ricarica

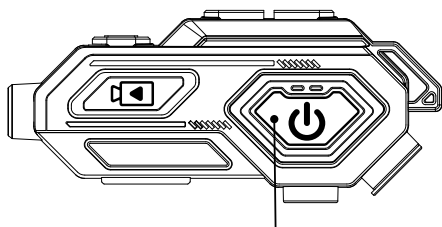

Luce indicatrice accesa
durante la ricarica

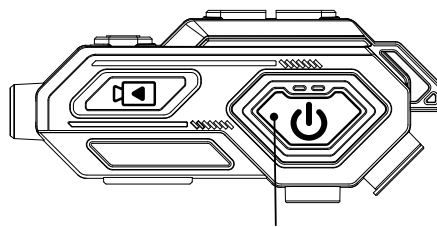

La luce indicatrice si spegne quando
è completamente carico

(Quando il dispositivo è acceso, collegare il caricatore spegnerà automaticamente il dispositivo)

• Funzione musicale

► Pausa/Play musica



(La musica si ferma)

Pressione breve



Pausa



(La musica suona)



Giocare

Tasto per abbassare il volume

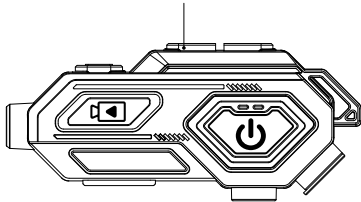

Pressione breve sulla traccia precedente



(La musica suona)



Pressione lunga per abbassare il volume

Tasto per alzare il volume

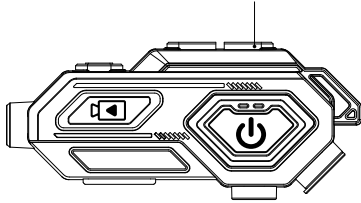

Pressione breve sulla traccia successiva



(La musica suona)



Pressione lunga per aumentare il volume

• Assistente vocale

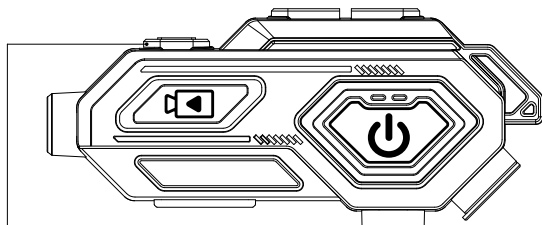

Tasto per assistente vocale



Pressione breve



Attivare l'assistente vocale

● Pairing di condivisione musicale

- Doppio clic sul pulsante WiFi dei dispositivi A/B, i dispositivi A/B entreranno in modalità di abbinamento per la condivisione musicale, con l'indicatore LED colorato del pulsante di accensione che lampeggia rapidamente.
- Una volta che i dispositivi A/B sono abbinati con successo, l'indicatore LED colorato del pulsante di accensione lampeggerà in modo intermittente.

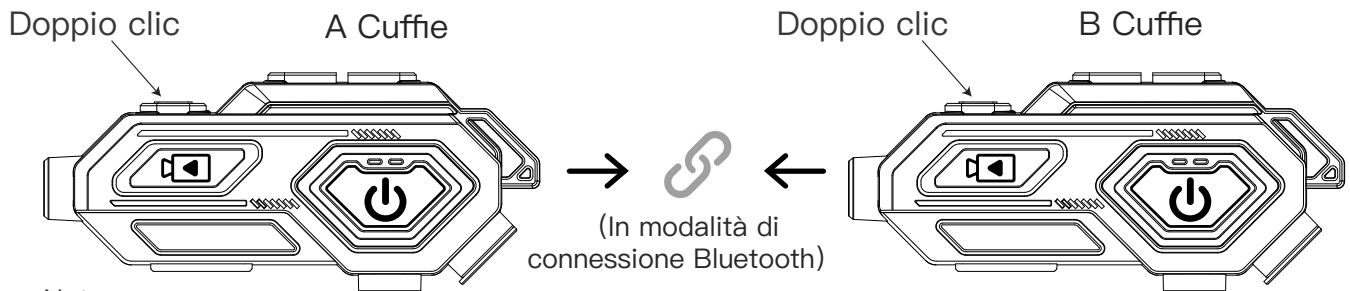

Nota:

1. In modalità di condivisione musicale, se i dispositivi A e B vengono disconnessi, l'indicatore del pulsante di accensione lampeggerà rapidamente per avvisare.
2. In modalità di condivisione musicale, i pulsanti di aumento/diminuzione del volume e di riproduzione sui dispositivi A e B possono controllare il telefono.

● Pairing intercom On/Off

- Doppio clic sul pulsante di volume "+" dei dispositivi A/B, i dispositivi A/B entreranno in modalità di abbinamento intercom, con l'indicatore LED verde del pulsante di accensione che lampeggia rapidamente.
- Una volta che i dispositivi A/B sono abbinati con successo, l'indicatore LED verde del pulsante di accensione lampeggerà in modo intermittente.

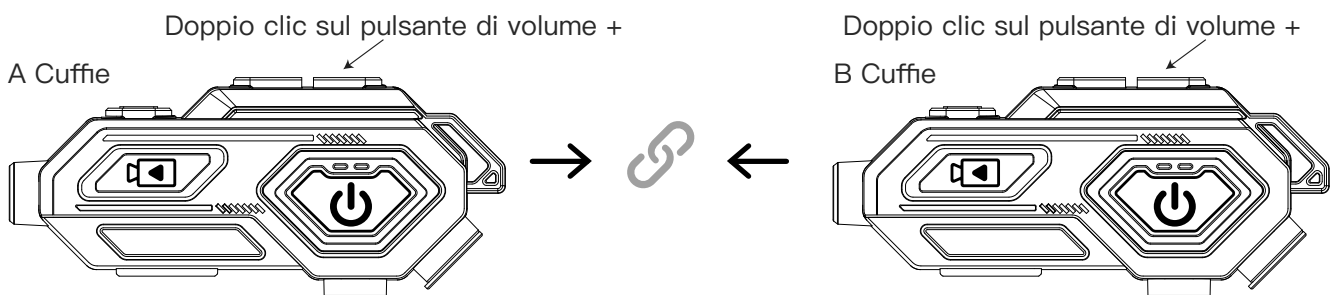

Nota:

1. In modalità intercom, se i dispositivi A e B vengono disconnessi, l'indicatore verde del pulsante di accensione lampeggerà rapidamente per avvisare.
2. Se i dispositivi A e B sperimentano ritardi o interruzioni, si riconnetteranno automaticamente quando avvicinati.
3. Quando si passa alla modalità intercom, la connessione Bluetooth del telefono verrà automaticamente disconnessa; tornando alla modalità Bluetooth, le cuffie si riconnetteranno automaticamente al telefono.

● Modalità FM

- Doppio clic sul pulsante del volume “+” per entrare in modalità FM, il LED arancione del pulsante di accensione lampeggia in modo intermittente.
- Premere brevemente i pulsanti di aumento/diminuzione del volume, e il dispositivo entrerà in modalità di ricerca semi-automatica, sospendendo la ricerca quando viene trovato un segnale radio chiaro, effettuando una ricerca sequenziale delle stazioni (il cavo dell’altoparlante deve essere collegato durante la ricerca)

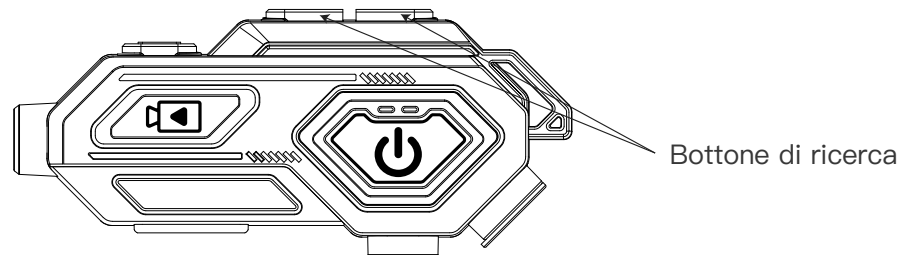

Nota:

1. In modalità FM, se non desideri ascoltare la radio, puoi premere il pulsante di accensione per silenziare; premendo di nuovo il pulsante di accensione tornerai allo stato audio.
2. A seconda dell’ambiente, potrebbe esserci a volte un suono di “fruscio”; ti preghiamo di provare a usarlo all’aperto o in aree aperte.

● Funzione di registrazione (Dashcam)

- Premere e tenere premuto l’interruttore di registrazione per 5 secondi per accendere/spegnere; inizierà automaticamente la registrazione dopo l’accensione.
- Premere brevemente il pulsante di registrazione per mettere in pausa/iniziare la registrazione.

L’indicatore LED verde lampeggia all’accensione e lampeggia lentamente durante la registrazione.

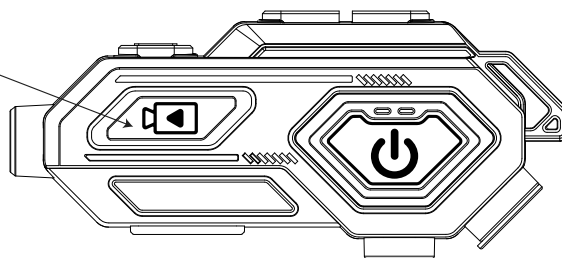

≤256G/C10

Nota:

1. I file video sulla scheda di memoria TF sono memorizzati in segmenti di 2 minuti (la lunghezza del tempo può essere impostata tramite l’app).
2. Il dashcam ha un alto consumo energetico; quando la batteria è bassa, si spegnerà immediatamente dopo l’accensione. La funzione Bluetooth (che ha un basso consumo energetico) può continuare a essere utilizzata dopo lo spegnimento automatico, il che è normale.
3. Alcune schede TF con determinate velocità potrebbero non essere compatibili con questo dispositivo; supporta una capacità massima di 256G con una velocità di scrittura di C10; le schede inferiori a C10 non sono supportate.
4. Se il sistema rileva che la scheda TF non è inserita dopo l’accensione, il dispositivo si spegnerà automaticamente dopo 3 minuti.
5. Il sistema del dashcam ha un alto consumo energetico; potrebbe riscaldarsi leggermente dopo un lungo utilizzo. L’apparecchio dispone di una funzione di rilevamento della temperatura, quindi usalo con fiducia.

● Funzione Wifi (Hotspot)

- Tieni premuto l'interruttore Wi-Fi per 5 secondi per accenderlo/spegnere. Dopo l'accensione, il telefono non è connesso al punto di accesso di backup. Si spegnerà automaticamente dopo 5 minuti.

L'indicatore LED arancione lampeggia all'accensione e lampeggia lentamente durante la connessione al telefono.

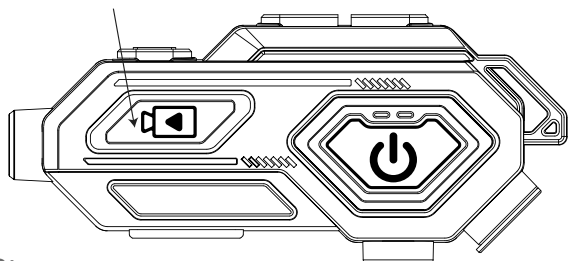

APP



APP

Nota:

1. Aprire un dispositivo Android o iOS e cercare l'app "Roadcam/GoPlus cam" nel market delle app o nell'App Store per scaricarla e installarla, oppure scansionare il codice QR su WeChat per scaricare; consentire l'accesso ai servizi informativi e alla fotocamera.
2. I percorsi di ricerca possono variare leggermente a seconda del dispositivo; seguire le istruzioni sull'interfaccia utente del telefono per l'installazione.
3. Durante la connessione dell'app del dispositivo al telefono, non è possibile connettersi ad altri hotspot WiFi.
4. Password dell'hotspot WiFi: 12345678 (può essere modificata nell'app).

● Funzione Wifi+APP (Hotspot) Installazione e utilizzo

- Tenere premuto il pulsante WiFi per 5 secondi per accenderlo/spegnere. Dopo l'accensione, l'indicatore LED arancione lampeggia rapidamente. La funzione di registrazione deve essere attivata prima di accendere il Wi-Fi

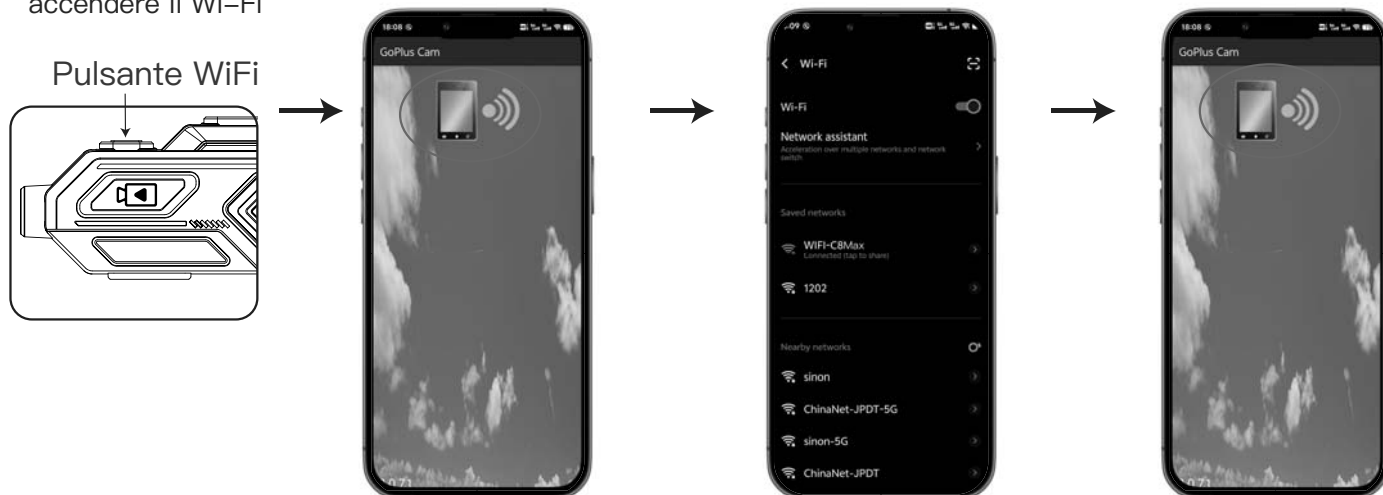

Fare clic sull'app scaricata per accedere a questa pagina, fare clic sull'icona di connessione e verrà automaticamente reindirizzato all'interfaccia Wi-Fi.

Accedere a questa pagina, fare clic su C8-Max e inserire la password iniziale: 12345678 per connettersi con successo.

RTornare alla pagina principale dell'app e fare clic sull'icona per continuare.

Nota:

1. Per tornare all'interfaccia principale dell'APP, scorri verso l'alto dall'angolo in basso a destra dello schermo del telefono.
2. I contenuti nella scheda di memoria possono essere copiati ed eliminati collegandosi a un computer tramite un cavo USB.
3. La funzionalità Gsonser e la sensibilità possono essere attivate o disattivate nell'APP.

Fare clic sull'icona dei file nell'angolo in alto a sinistra per visualizzare i video registrati e le immagini memorizzate.

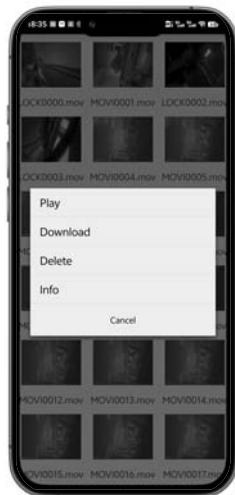

Interfaccia della fotocamera



Disconnettere

Pausa/Continua

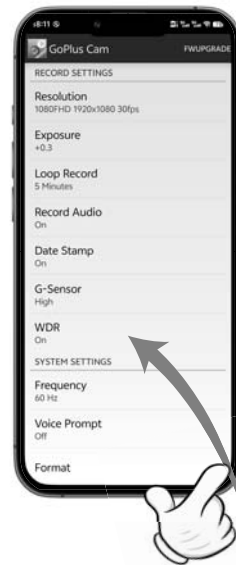

Fare clic sull'icona delle impostazioni nell'angolo in alto a destra per accedere a vari parametri.

Um zum Hauptbedienungs-bildschirm der APP zurückzukehren, wischen Sie von der unteren rechten Ecke des Telefonbildschirms nach oben.

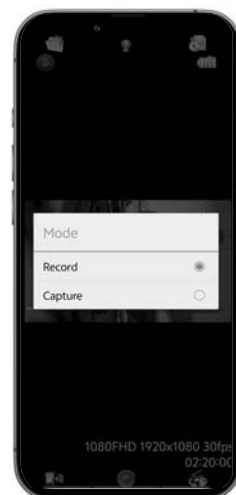

Per tornare all'interfaccia principale dell'APP, scorri verso l'alto dall'angolo in basso a destra dello schermo del telefono.

• Modalità USB

- Il prodotto può essere utilizzato per collegarsi a un computer per copiare ed eliminare video e foto

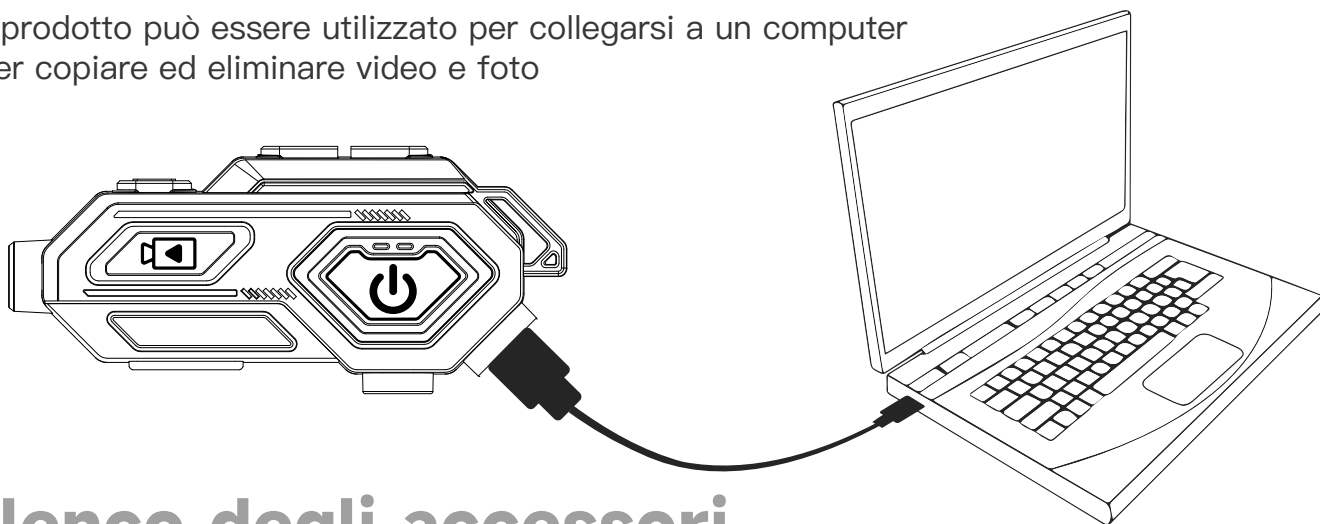

• Elenco degli accessori

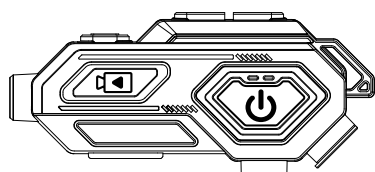

C8Max*1

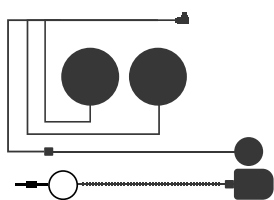

Cuffie e Microfono*1

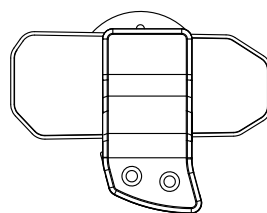

Clip*1

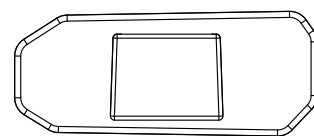

Clip adesivo
biadesivo*1

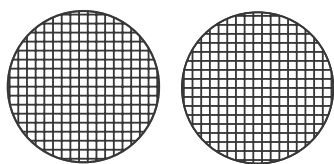

Nastro adesivo
per altoparlante*2

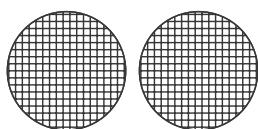

Nastro adesivo per
microfono*2

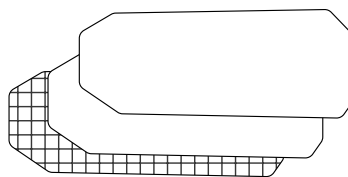

Nastro adesivo
per clip*3

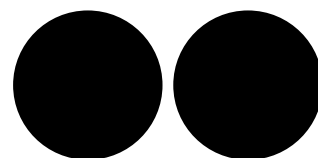

Cuscinetto rialzato*2

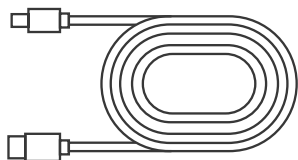

Cavo dati*1

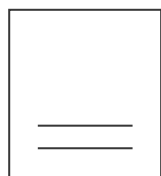

Manuale utente*1



Scheda TF*1

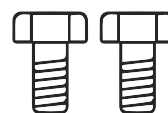

Viti*2

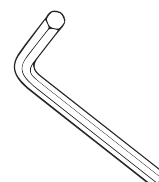

Chiave di installazione*1

• Note

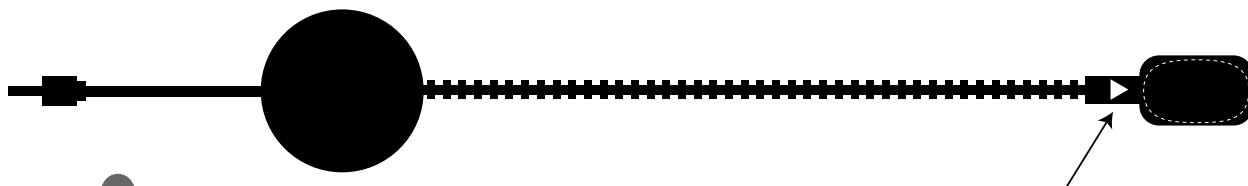

Per vivere un'esperienza di chiamata di alta qualità, dopo aver installato il microfono rigido, assicurati che il simbolo < > sia allineato con la direzione della tua bocca; altrimenti, potrebbero esserci rumori durante la chiamata.



Operazione di reset: Se si verificano problemi come pulsanti non reattivi, tieni premuto il pulsante di accensione per 16 secondi. La luce rossa lampeggerà per 1 secondo per indicare lo spegnimento. Puoi quindi riaccenderlo per eliminare eventuali anomalie.



(Download dell'APP)

Manual del Usuario

Descripción del Producto

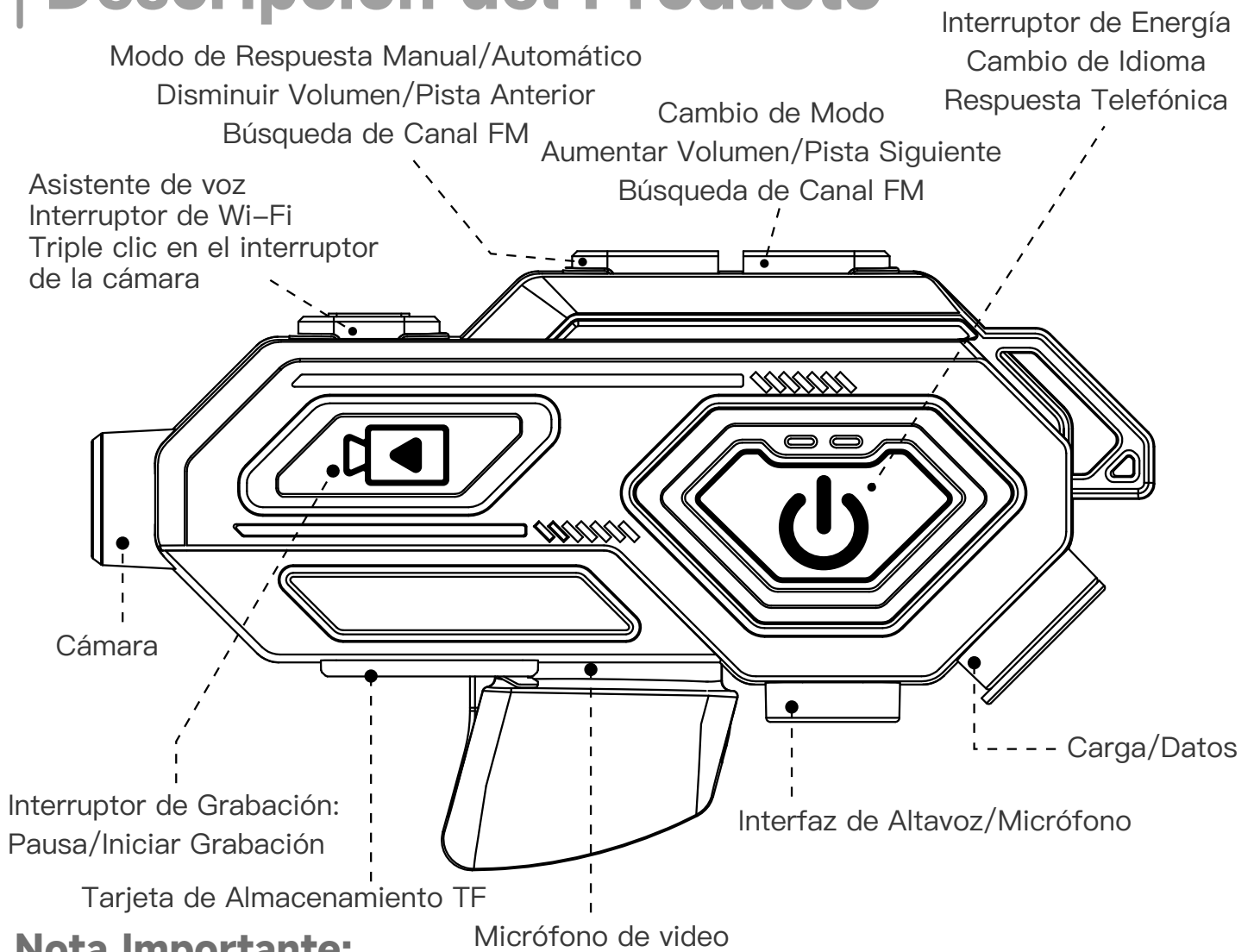

Nota Importante:

1. Conecta el teléfono para probar el volumen y verificar la tarjeta TF antes de instalar los auriculares.
2. Ajusta la posición del altavoz si hay diferencia de volumen tras la instalación.
Carga si aparece aviso de batería baja.
3. El alto consumo de energía es normal; la función Bluetooth puede estar disponible tras un apagado por batería baja.

• Funciones del Teléfono

Doble toque Volumen (-)

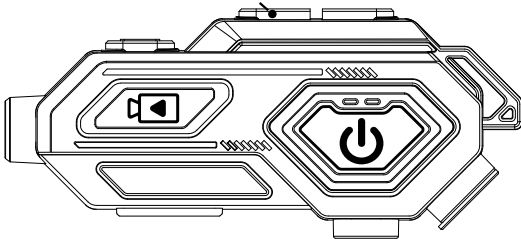

→
(Al conectar Bluetooth)

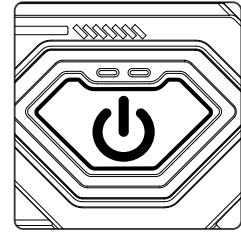

Cambiar a modo manual/automático

Cambiar de modo cuando no está conectado al teléfono

Modo Automático (respuesta automática después de 10 segundos)

Durante una llamada, doble toque en el botón de encendido para alternar entre teléfono y dispositivo



((Llamada Entrante)
(Después de 10 segundos)

Automático

Respuesta Automática



(Llamada Entrante)

Respuesta Manual para Llamada Entrante

Responder



(Llamada Entrante)

Mantener 2 segundos

Rechazar Llamada



(Actualmente en llamada)

"Pulsación Corta" Durante la Llamada

Terminar Llamada



Doble toque

Redireccionar Último Número

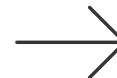

(Mientras continúa la llamada)

Pulsación Corta

Cancelar Llamada Actual

• Poder Encendido/Apagado

▶ Encender/Apagar la alimentación

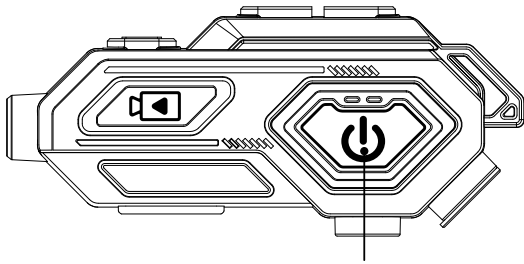

Mantener presionado durante 3 segundos para encender el dispositivo

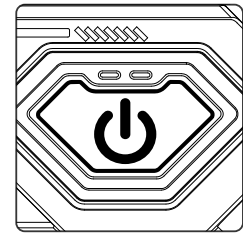

Luz LED encendida

• Parear teléfono y auriculares

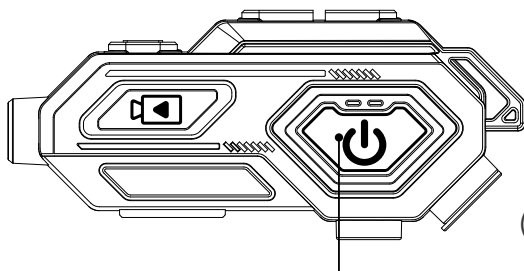

Bluetooth no conectado
LED parpadeando

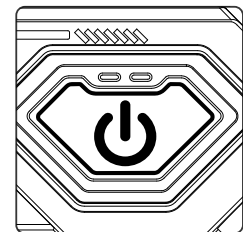

Bluetooth conectado,
LED parpadeando intermitentemente

• Modo de Carga

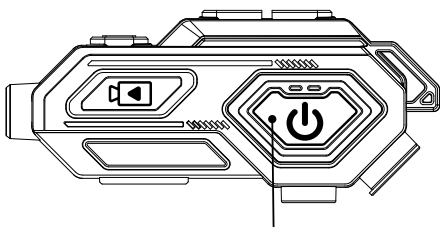

Luz indicadora encendida
mientras se carga

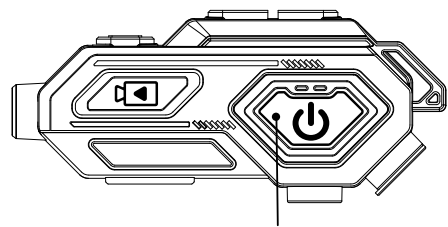

La luz indicadora se apaga cuando
está completamente cargado

(Cuando el dispositivo está encendido, conectar el cargador apagará automáticamente el dispositivo)

• Función de música

▶ Pausar/Reproducir música



Pulsar corto

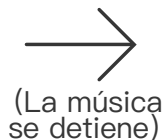

(La música se detiene)



Pausa



(La música suena)



Reproducir

Tecla de bajar volumen

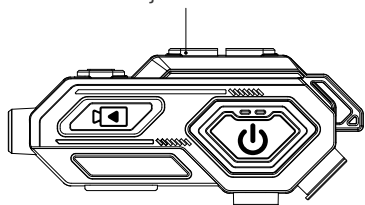

Pulsar corto pista anterior



(La música suena)

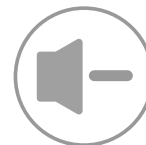

Pulsar largo para bajar volumen

Tecla de subir volumen

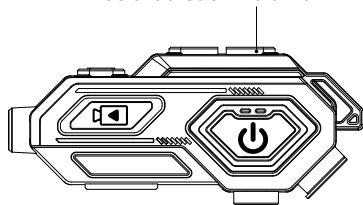

Pulsar corto pista siguiente



(La música suena)



Pulsar largo para subir volumen

• Asistente de voz

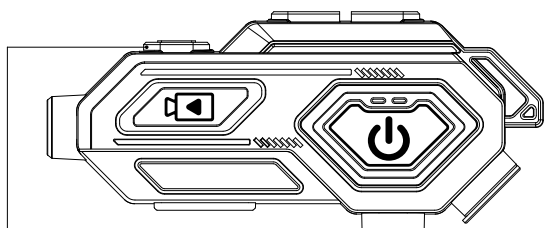

Tecla de asistente de voz



Pulsar corto



Despertar al asistente de voz

• Pareado de compartir música

- Doble clic en el botón WiFi de los dispositivos A/B, y los dispositivos A/B entrarán en modo de pareado de compartir música, con el indicador LED de colores del botón de encendido parpadeando rápidamente.
- Una vez que los dispositivos A/B estén emparejados con éxito, el indicador LED de colores del botón de encendido parpadeará intermitentemente.v

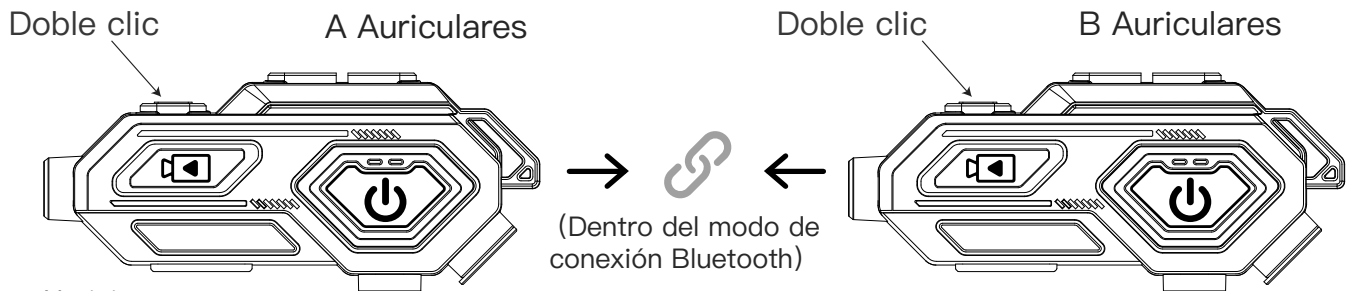

Noticia:

1. En modo de compartir música, si los dispositivos A y B se desconectan, el indicador del botón de encendido parpadeará rápidamente para alertar.
2. En modo de compartir música, los botones de subir/bajar el volumen y de reproducción en los dispositivos A y B pueden controlar el teléfono.

• Pareado de intercomunicador Encendido/Apagado

- Doble clic en el botón de volumen "+" de los dispositivos A/B, y los dispositivos A/B entrarán en modo de pareado de intercomunicador, con el indicador LED verde del botón de encendido parpadeando rápidamente.
- Una vez que los dispositivos A/B estén emparejados con éxito, el indicador LED verde del botón de encendido parpadeará intermitentemente.

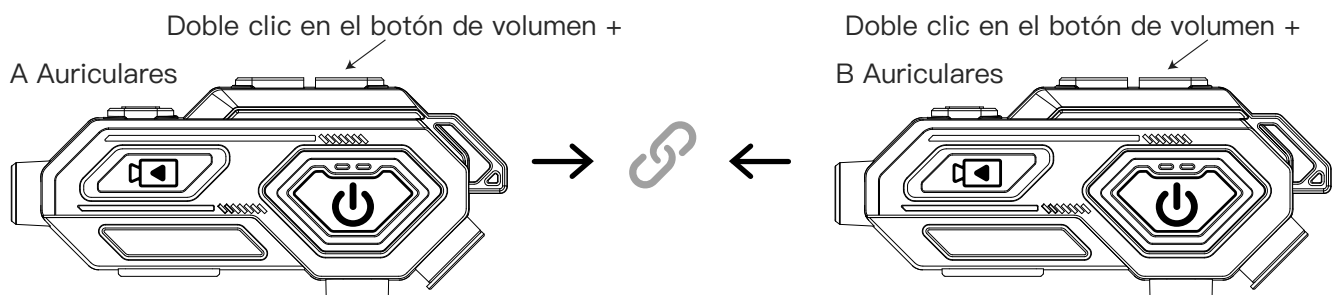

Noticia:

1. En modo de intercomunicador, si los dispositivos A y B se desconectan, el indicador verde del botón de encendido parpadeará rápidamente para alertar.
2. Si los dispositivos A y B experimentan retrasos o interrupciones, se volverán a conectar automáticamente cuando estén cerca.
3. Al cambiar al modo de intercomunicador, la conexión Bluetooth del teléfono se desconectará automáticamente; al volver al modo Bluetooth, los auriculares se volverán a conectar automáticamente al teléfono.

• Modo FM

- Doble clic en el botón de volumen “+” para entrar en modo FM, el LED naranja del botón de encendido parpadea de forma intermitente.
- Presione brevemente los botones de volumen +/-, y el dispositivo entrará en modo de búsqueda semiautomático, pausando la búsqueda cuando se encuentre una señal de radio clara, buscando las estaciones de manera secuencial (asegúrese de que el cable del altavoz esté conectado durante la búsqueda).

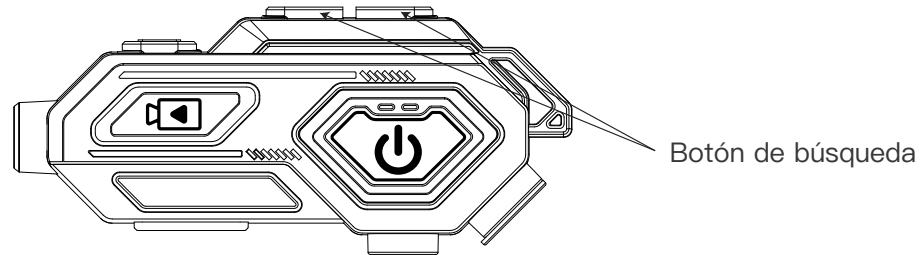

Noticia:

1. En modo FM, si no deseas escuchar la radio, puedes presionar el botón de encendido para silenciar; presionando nuevamente el botón de encendido volverás al estado de sonido.
2. Dependiendo del entorno, a veces puede haber un sonido de "susurro"; intenta usarlo al aire libre o en áreas abiertas.

• Función de grabación (Dashcam)

- Mantenga presionado el interruptor de grabación durante 5 segundos para encender/apagar; comenzará a grabar automáticamente después de encender.
- Presione brevemente el botón de grabación para pausar/iniciar la grabación.

El LED verde parpadea al encenderse y parpadea lentamente durante la grabación.

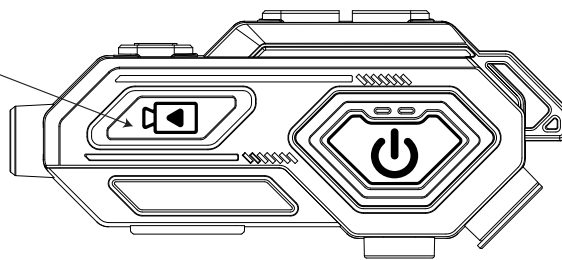

≤256G/C10

Nota:

1. Los archivos de video en la tarjeta de almacenamiento TF se almacenan en segmentos de 2 minutos (la longitud del tiempo se puede configurar a través de la aplicación).
2. La dashcam tiene un alto consumo de energía; cuando la batería está baja, se apagará inmediatamente después de encenderse. La función Bluetooth (que tiene un bajo consumo de energía) puede seguir usándose después del apagado automático, lo cual es normal.
3. Algunas tarjetas TF con ciertas velocidades pueden no ser compatibles con este dispositivo; admite una capacidad máxima de 256G con una velocidad de escritura de C10; las tarjetas inferiores a C10 no son compatibles.
4. Si el sistema detecta que no hay tarjeta TF insertada después de encender, el dispositivo se apagará automáticamente después de 3 minutos.
5. El sistema de la dashcam tiene un alto consumo de energía; puede calentarse ligeramente después de un uso prolongado. El dispositivo tiene una función de detección de temperatura, así que úselo con confianza.

• Función Wifi (Hotspot)

- Mantén presionado el interruptor de Wi-Fi durante 5 segundos para encenderlo/apagarlo. Después de encenderlo, el teléfono no está conectado al punto de acceso de respaldo. Se apagará automáticamente después de 5 minutos.

El LED naranja parpadea al encenderse y parpadea lentamente cuando se conecta al teléfono.

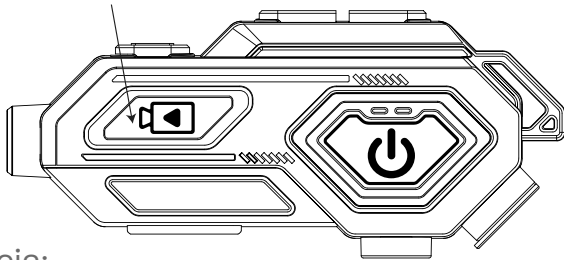

APP



APP

Noticia:

1. Abra un dispositivo Android o iOS y busque la APP "Roadcam/GoPlus cam" en el mercado de aplicaciones o en el App Store para descargarla e instalarla, o escanee el código QR en WeChat para descargar; y permita el acceso a los servicios de información y a la cámara.
2. Los caminos de búsqueda pueden variar ligeramente según el dispositivo; siga las instrucciones en la interfaz de uso del teléfono del usuario para instalar.
3. No se puede conectar a otros hotspots WiFi durante el proceso de conexión de la APP del dispositivo al teléfono.
4. Contraseña del hotspot WiFi: 12345678 (se puede modificar en la APP).

• Función Wifi+APP (Hotspot) Instalación y uso

- Mantenga presionado el botón de WiFi durante 5 segundos para encenderlo/apagarlo. Después de encenderse, el LED naranja parpadea rápidamente. (La función de grabación debe estar activada antes de encender el Wi-Fi)

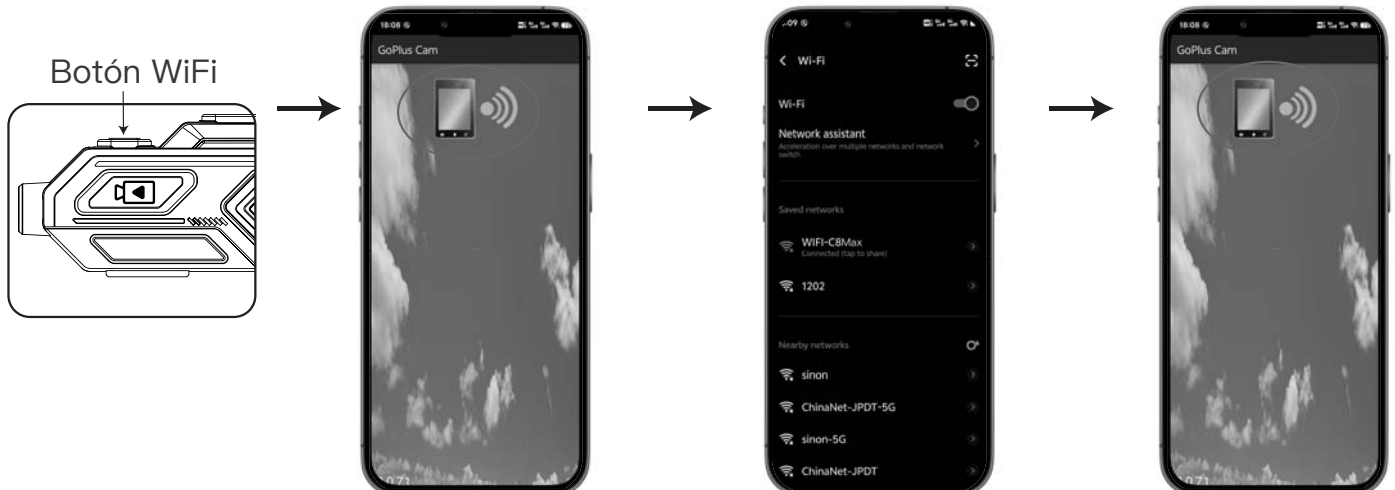

Haga clic en la APP descargada para acceder a esta página, haga clic en el ícono de conexión y se redirigirá automáticamente a la interfaz de Wi-Fi.

Ingrese a esta página, haga clic en C8-Max e ingrese la contraseña inicial: 12345678 para conectar con éxito.

Vuelva a la página principal de la APP y haga clic en el ícono para continuar.

Nota:

1. Para regresar a la interfaz principal de la APP, deslice hacia arriba desde la esquina inferior derecha de la pantalla del teléfono.
2. El contenido en la tarjeta de almacenamiento se puede copiar y eliminar conectando a una computadora a través de un cable de datos USB.
3. La funcionalidad Gsonser y la sensibilidad se pueden activar o desactivar en la APP.

Haga clic en el ícono de archivo en la esquina superior izquierda para ver los videos grabados y las imágenes almacenadas.



Interfaz de cámara



Desconectar

Pausa/Continuar



Haga clic en el ícono de configuración en la esquina superior derecha para acceder a varios ajustes de parámetros.

Para regresar a la interfaz principal de la APP, deslice hacia arriba desde la esquina inferior derecha de la pantalla del teléfono.

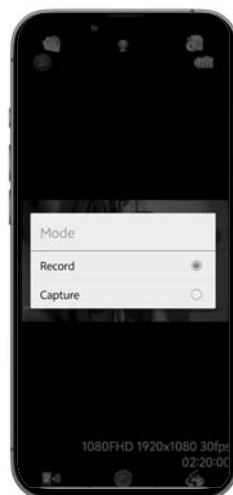

Haga clic en el ícono en la esquina inferior derecha para cambiar entre el modo de grabación de video y el modo de fotografía.

• Modo USB

- El producto se puede usar para conectarse a una computadora para copiar y eliminar videos y fotos

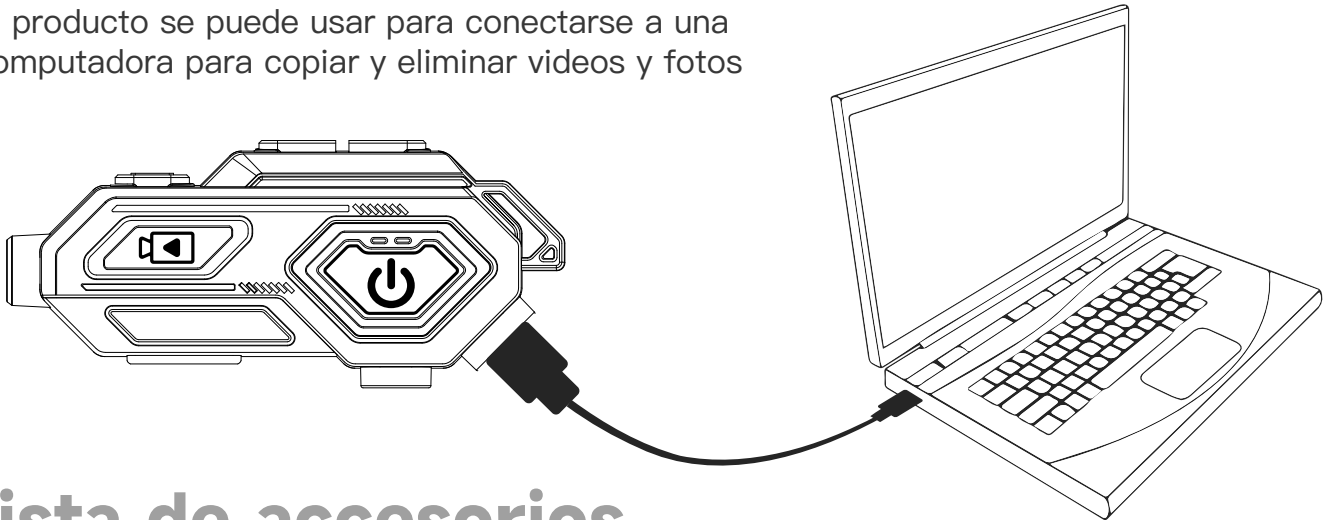

• Lista de accesorios

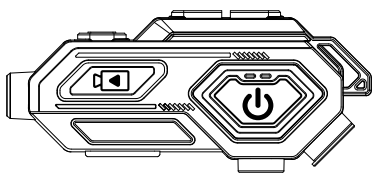

C8Max*1

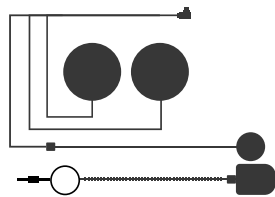

Auriculares y
Micrófono*1

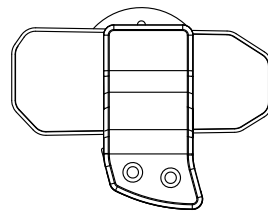

Clip*1

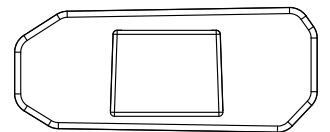

Clip adhesivo de
doble cara*1

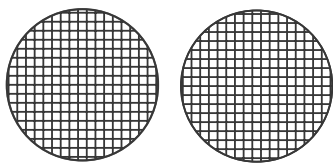

Cinta adhesiva
para altavoz*2

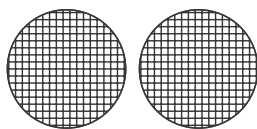

Cinta adhesiva para
micrófono*2

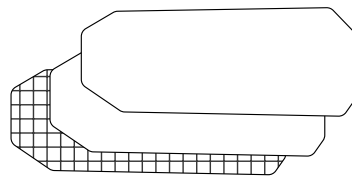

Cinta adhesiva
para clip*3

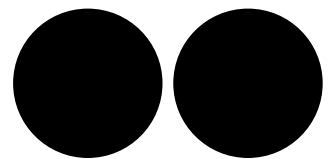

Almohadilla
elevadora*2

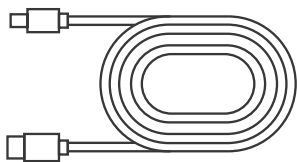

Cable de datos*1

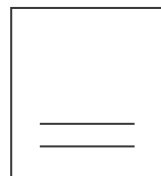

Manual del
usuario*1



Tarjeta TF*1

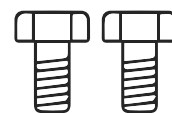

Tornillos*2

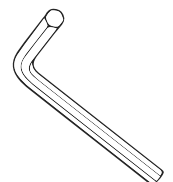

Llave de
instalación*1

• Note

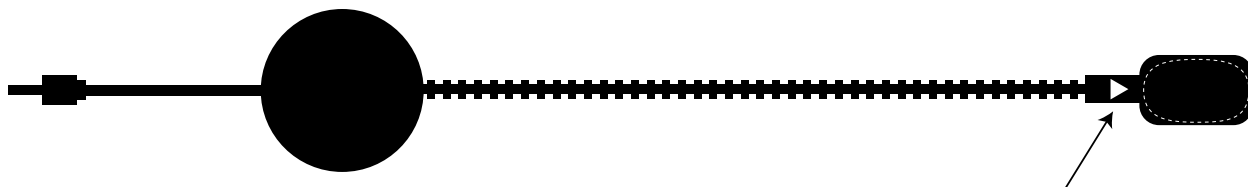

Para experimentar una alta calidad en las llamadas, después de instalar el micrófono duro, asegúrate de que el símbolo < > esté alineado con la dirección de tu boca; de lo contrario, puede haber ruido durante la llamada.



Operación de reinicio: Si encuentras problemas como botones sin respuesta, mantén presionado el botón de encendido durante 16 segundos. La luz roja parpadeará durante 1 segundo para indicar que se apaga. Luego puedes volver a encenderlo para eliminar cualquier anomalía.



(Descarga de la APP)



(APP Download)