

HELMET WIRELESS EARPHONE

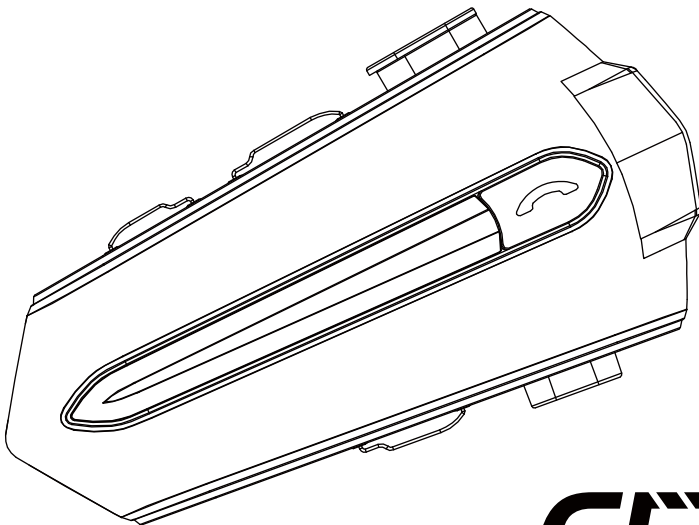

This device complies with Part 15 of the FCC Rules. Operation is subject to the following two conditions:

- (1) This device may not cause harmful interference.
- (2) This device must accept any interference received, including interference that may cause undesired operation.

English	01–06
French	07–12
German	13–18
Italian	19–24
Spanish	25–30
Japanese.....	31–36
Chinese	37–42

USER MANUAL

Product overview

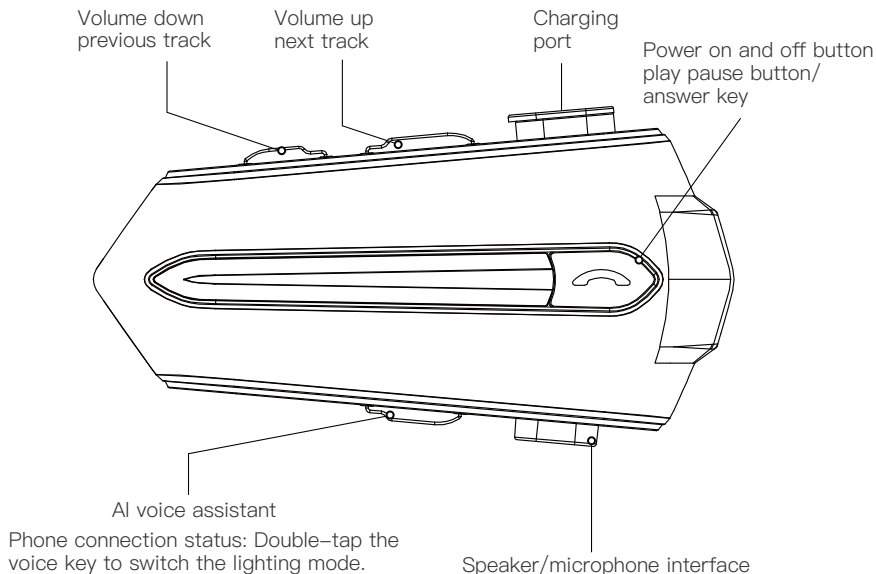

Important Notice:

Before installation the headphones, please connect them to your phone and test the volume level. If you notice a significant difference in volume after installing them into the helmet, adjust the speakers to the appropriate position inside the helmet.

When the battery is low, you'll hear a voice saying "Low Battery". Please charge the device promptly.

•Phone features

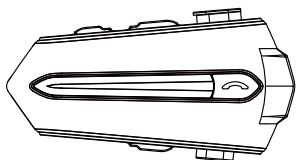

Switch to answer

Automatic mode (⊖ wait 10 seconds and then answer automatically!)

→
(When Bluetooth is not connected)

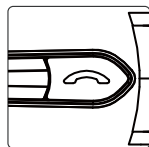

Double click on/off button to switch between manual answer and automatic answer

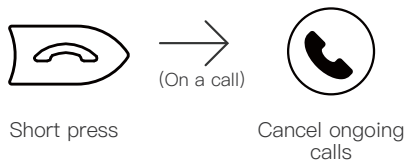
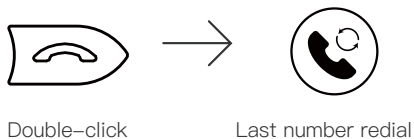
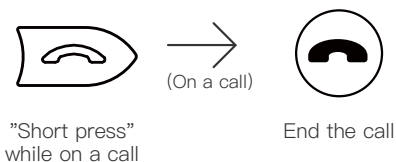
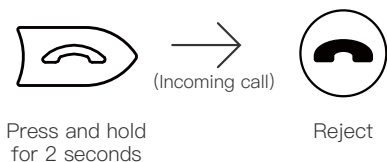
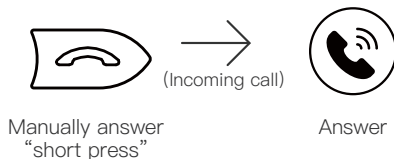
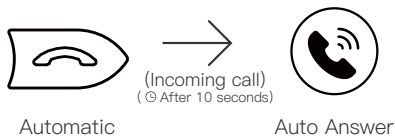

• Power on/off

▶ Power on/off

"Triple click to switch between Chinese and English voice
(Bluetooth disconnected)."

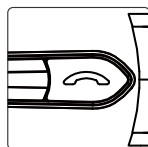
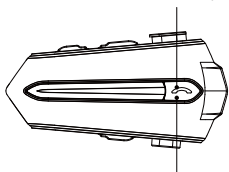

LED Lights on

Press and hold for 3 seconds to
turn on the device

• Paring

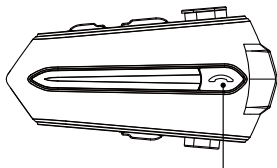

Bluetooth not connected
LED flash

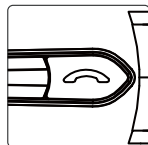

Bluetooth not connected
LED Flash

• Lights on and off

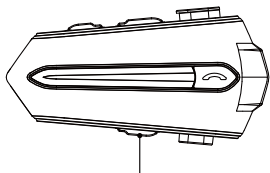

Phone connection status: Double-tap
the voice key to switch the lighting mode.

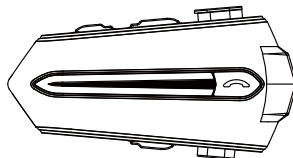

Lights

• Music features

▶ Pause/Play music

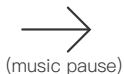

(music pause)

Short Press



Play



(music playing)



Pause

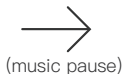
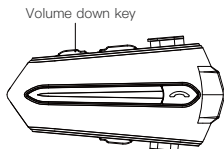

(music pause)

Short press for previous track



(music playing)

Long press to volume down

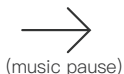
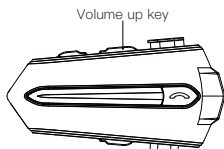

(music pause)

Short press for next track



(music playing)

Long press to volume up



• Voice assistant

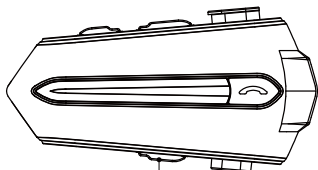

Voice Assistant Key



Short Press



Wake up the voice assistant

●Charging mode

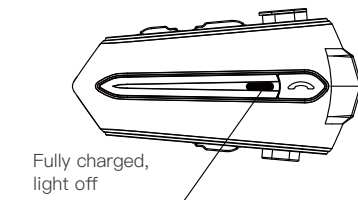
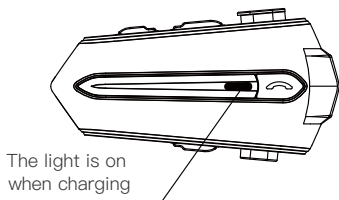

(When the device is on, plug in the Charger and the device will shut down automatically)

●Accessories

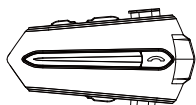

C5S*1

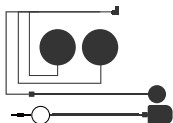

Headphones and
Microphone*1

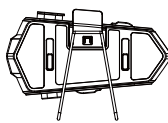

Clamping base*1

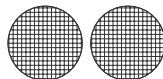

Microphone Velcro
tape*2

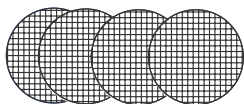

Speaker Velcro
tape*4

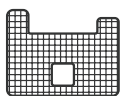

Velcro
tape*1



thick double
sided tape*1



Stand Velcro
tape*1

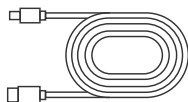

charging cable*1



User manual*1

•Note

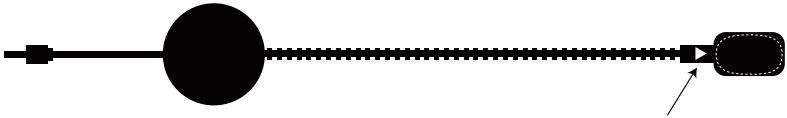

After installation the hard microphone, please ensure that the < ► > symbol is aligned with the direction of your mouth; otherwise, there may be noise during the call.

NOTE: This equipment has been tested and found to comply with the limits for a Class B digital device, pursuant to part 15 of the FCC Rules. These limits are designed to provide reasonable protection against harmful interference in a residential installation. This equipment generates, uses and can radiate radio frequency energy and, if not installed and used in accordance with the instructions, may cause harmful interference to radio communications. However, there is no guarantee that interference will not occur in a particular installation. If this equipment does cause harmful interference to radio or television reception, which can be determined by turning the equipment off and on, the user is encouraged to try to correct the interference by one or more of the following measures:

- Reorient or relocate the receiving antenna.
- Increase the separation between the equipment and receiver.
- Connect the equipment into an outlet on a circuit different from that to which the receiver is connected.
- Consult the dealer or an experienced radio/TV technician for help

Changes or modifications not expressly approved by the party responsible for compliance could void the user's authority to operate the equipment.

This device complies with Part 15 of the FCC Rules. Operation is subject to the following two conditions: (1) this device may not cause harmful interference, and (2) this device must accept any interference received, including interference that may cause undesired operation.

Manuel de l'utilisateur

| Aperçu du produit

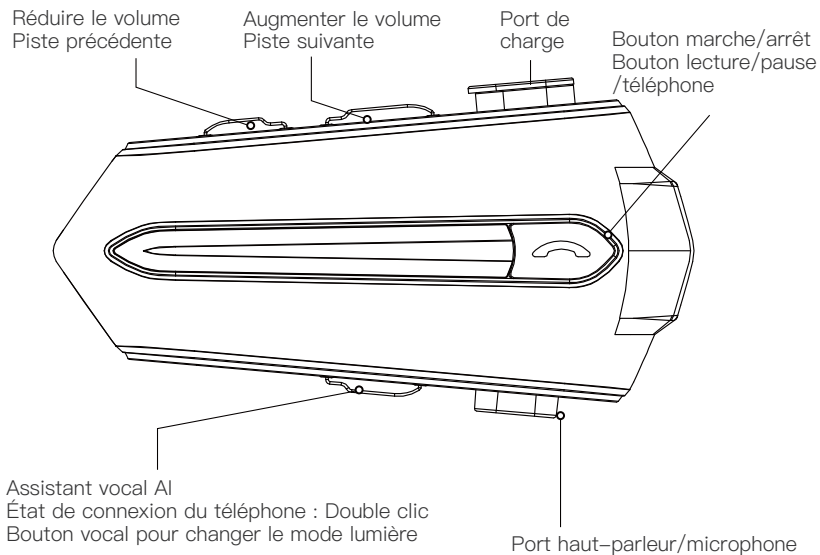

Conseils importants :

Avant de connecter les écouteurs, veuillez tester le volume en connectant votre téléphone.

Si vous remarquez une grande différence de volume après l'installation du casque, veuillez ajuster la position appropriée des haut-parleurs à l'intérieur du casque.

Si vous entendez un signal sonore indiquant une faible batterie, veuillez recharger l'appareil rapidement.

• Fonctionnalités du téléphone

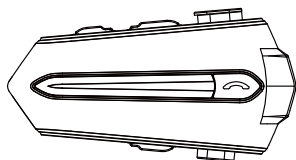

Passer en mode réception

Mode automatique (Ⓞ attendre 10 secondes puis répondre automatiquement)

→
(Pas de connexion Bluetooth)

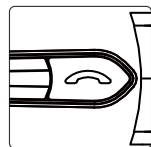

Double-cliquez sur le bouton d'alimentation pour basculer entre la réponse manuelle et automatique

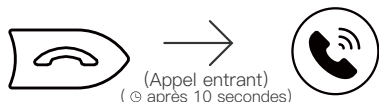

Automatique

Réponse automatique

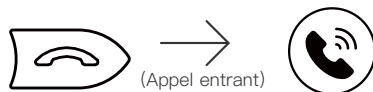

Appel entrant
Répondre manuellement

Répondre

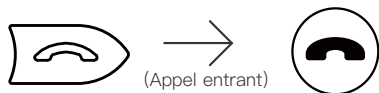

Maintenez enfoncé pendant 2 secondes

Refuser l'appel

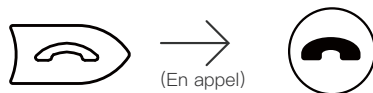

Appuyez brièvement
Pendant un appel

Terminer l'appel

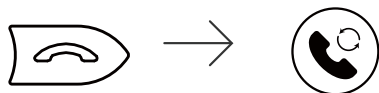

Double-cliquez

Rappeler le dernier numéro

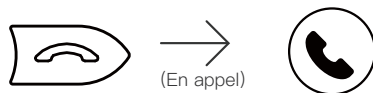

Appuyez brièvement

Annuler l'appel en cours

●Alimentation marche/arrêt

► Allumer/éteindre l'alimentation

Trois clics consécutifs pour basculer entre les annonces vocales en chinois et anglais (Bluetooth déconnecté)

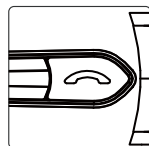
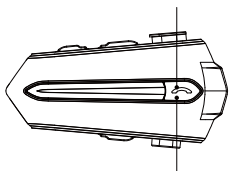

La LED s'allume

Maintenez enfoncé pendant 3 secondes pour allumer l'appareil

●Appariement

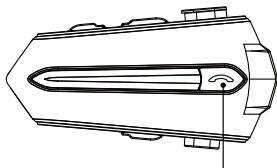

Bluetooth non connecté
La LED clignote

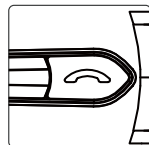

Bluetooth non connecté,
la LED clignote

●Allumé et éteint

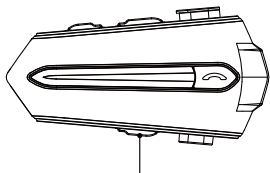

État de connexion du téléphone : Double clic
Bouton vocal pour changer le mode lumière

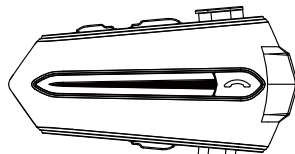

La lumière est allumée

• Fonctionnalités musicales

► Pause/Lecture de la musique



(Arrêt de la musique)

Appui court



Lecture



(Lecture de la musique)



Pause

Bouton de diminution du volume

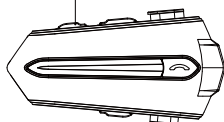

(Arrêt de la musique)

Appui court pour la piste précédente



(Lecture de la musique)



Maintien long pour
diminuer le volume

Bouton d'augmentation du volume

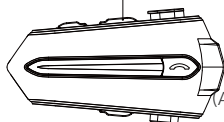

(Arrêt de la musique)

Appui court pour la piste suivante



(Lecture de la musique)



Maintien long pour
augmenter le volume

• Assistant vocal

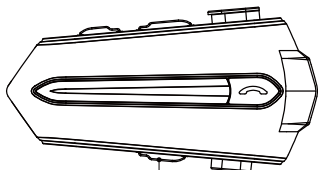

Touche de l'assistant vocal



Appui court



Réveil de l'assistant
vocal

• Mode de charge

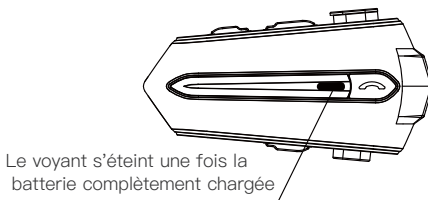
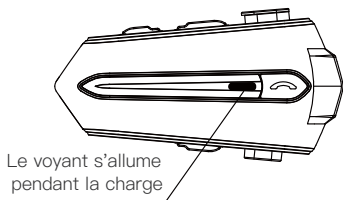

(Lorsque l'appareil est allumé, insérez le chargeur et l'appareil s'éteindra automatiquement)

• Liste des accessoires

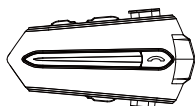

C5S*1

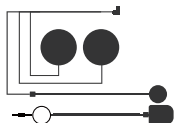

Écouteurs et microphone *1

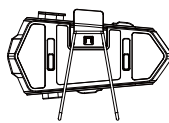

Station d'accueil à pince *1

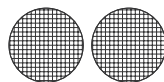

Autocollants magiques pour microphone *2

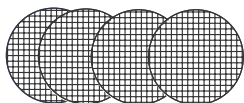

Autocollants magiques pour haut-parleurs *4

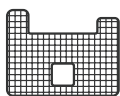

Autocollant magique pour support *1



Ruban adhésif double face épais *1



Autocollant magique pour support *1

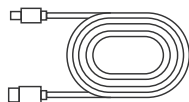

Câble de charge *1

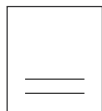

Manuel d'utilisation *1

•Note

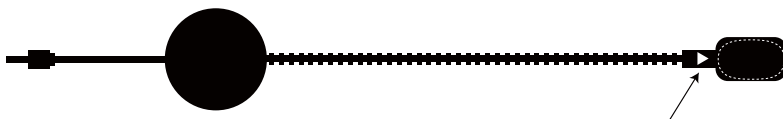

Pour une expérience d'appel de haute qualité, une fois le microphone rigide installé. Assurez-vous que les symboles ◀ ▶ > sont alignés avec la direction de la bouche, sinon il peut y avoir des bruits parasites lors des appels.

Benutzerhandbuch

Produktübersicht

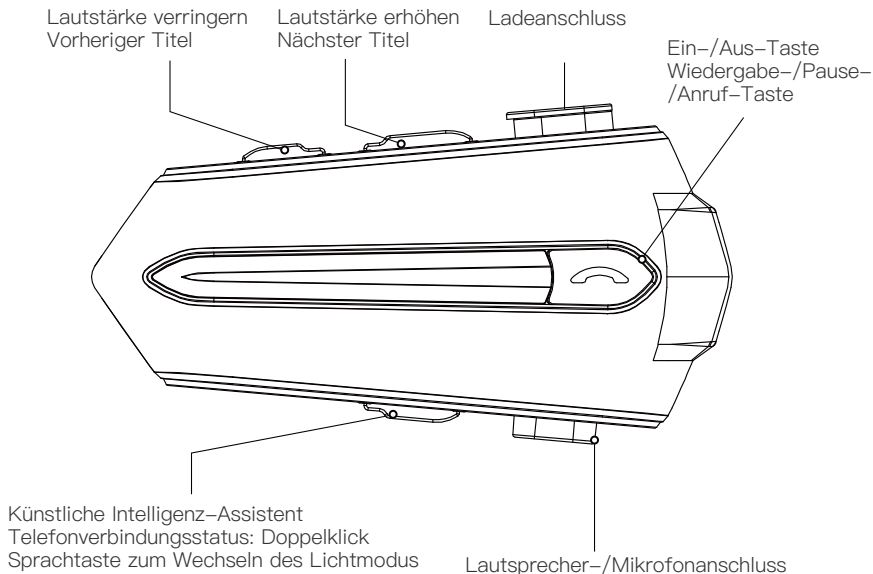

Wichtige Hinweise:

Bevor Sie die Kopfhörer anschließen, testen Sie bitte die Lautstärke, indem Sie Ihr Telefon anschließen.

Wenn Sie einen großen Unterschied in der Lautstärke nach der Installation des Helms feststellen, stellen Sie bitte die richtige Position der Lautsprecher im Helm ein.

Wenn Sie einen Signalton hören, der eine niedrige Batterie anzeigt, laden Sie das Gerät bitte rechtzeitig auf.

•Telefonfunktionen

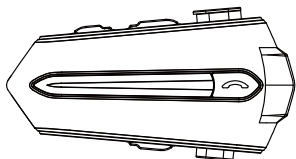

→
(Keine Bluetooth-Verbindung)

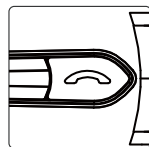

Zum Empfangsmodus wechseln

Automatischer Modus (☹️warten Sie 10 Sekunden und dann automatisch antworten!)

Doppelklicken Sie auf die Ein-/Aus-Taste, um zwischen manueller und automatischer Antwort und zwischen automatischer Antwort zu wechseln

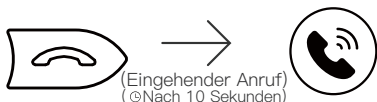

(Eingehender Anruf)
(☹️Nach 10 Sekunden)

Automatisch

Automatische Antwort Eingehender Anruf
Manuell antworten



(Eingehender Anruf)

Anruf annehmen



(Eingehender Anruf)

Drücken und halten Sie
2 Sekunden lang

Ablehnen

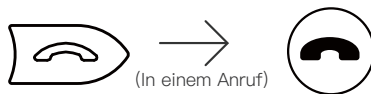

(In einem Anruf)

"Kurzer Druck"
Während eines Anrufs

Anruf beenden



Doppelklick

Letzte Nummer wählen

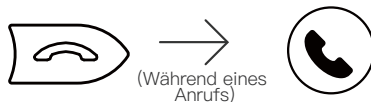

(Während eines Anrufs)

Kurzer Druck

Laufenden Anruf
abbrechen

•Stromversorgung ein-/ausschalten

▶ Stromversorgung ein-/ausschalten

Dreimaliges Tippen zum Wechsel zwischen chinesischer und englischer Sprachansage
(Bluetooth ist getrennt)

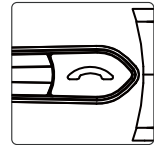
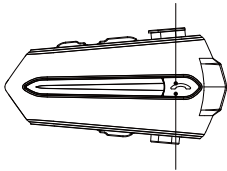

Die LED leuchtet

Drei Sekunden lang gedrückt halten,
um das Gerät einzuschalten

•Paarung

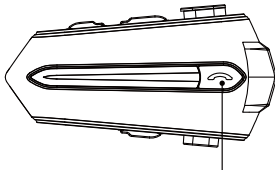

Bluetooth nicht verbunden
Die LED blinkt

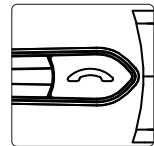

Bluetooth nicht verbunden,
die LED blinkt

•Ein- und Ausschalten

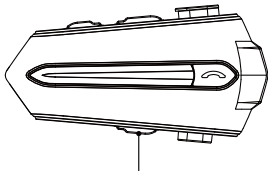

Verbindungsstatus des Telefons: Doppelklick
Sprachtaste zum Ändern des Lichtmodus

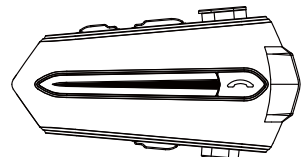

Das Licht ist an

• Musikfunktionen

▶ Musik pausieren/wiedergeben



→
(Musik stoppen)



→
(Wiedergabe von Musik)



Kurz drücken

Wiedergabe

Pause

Lautstärke verringern

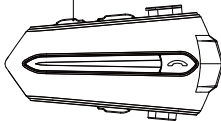

→
(Musik stoppen)



→
(Wiedergabe von Musik)



Kurz drücken für vorherigen Titel

Lange drücken zum Verringern der Lautstärke

Lautstärke erhöhen

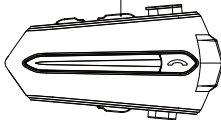

→
(Musik stoppen)



→
(Wiedergabe von Musik)



Kurz drücken für nächsten Titel

Lange drücken zum Erhöhen der Lautstärke

• Sprachassistent

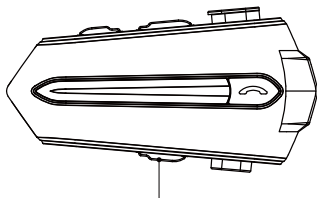

Taste für den Sprachassistenten

→
Kurz drücken



Aktivierung des Sprachassistenten

•Lademodus

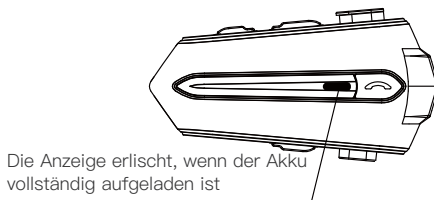
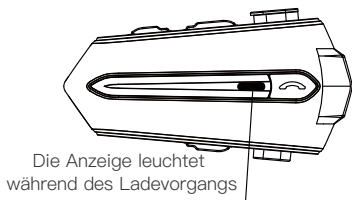

(Wenn das Gerät eingeschaltet ist, schließen Sie das Ladegerät an und das Gerät wird automatisch heruntergefahren)

•Liste der Zubehörteile

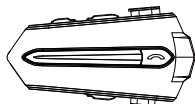

C5S*1

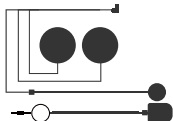

Kopfhörer und
Mikrofon *1



Klemmbare
Dockingstation *1

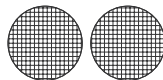

Magische Klebebänder
für Mikrofone *2

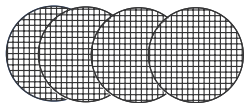

Magische Klebebänder
für Lautsprecher *4

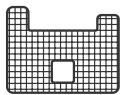

Magisches Klebeband
für Ständer *1



Doppelseitiges Klebeband
in dicker Ausführung *1



Magisches Klebeband
für Ständer *1

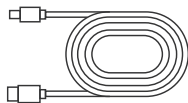

Ladekabel *1



Bedienungsanleitung *1

•Note

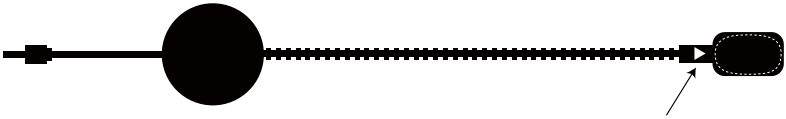

Für eine qualitativ hochwertige Anruf-Erfahrung, stellen Sie sicher, dass das harte Mikrofon richtig installiert ist. Achten Sie darauf, dass die Symbole <▶> in Richtung des Mundes ausgerichtet sind, da sonst Störgeräusche während des Anrufs auftreten können.

Manuale utente

| Panoramica del prodotto

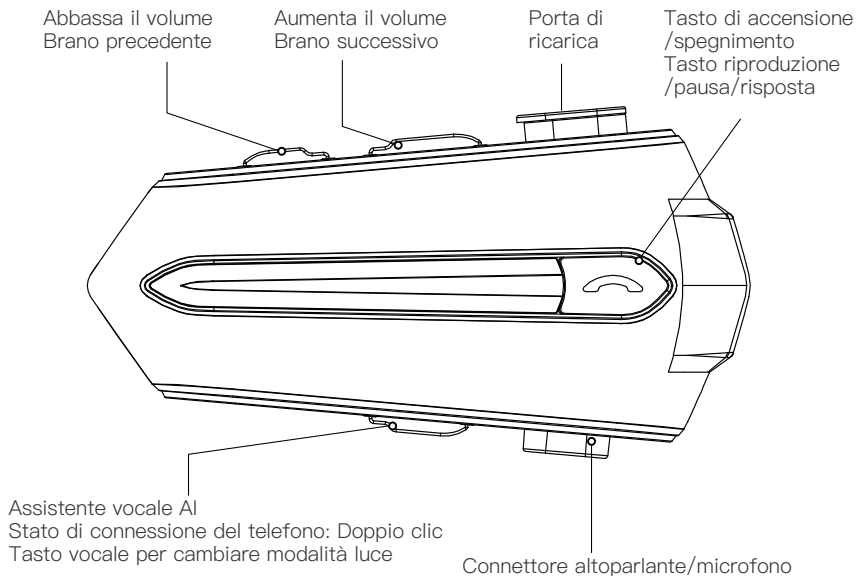

Avvertenze importanti:

Prima di collegare le cuffie, ti preghiamo di testare il volume collegando il tuo telefono.

Se noti una grande differenza di volume dopo l'installazione del casco, ti preghiamo di regolare la posizione appropriata degli altoparlanti all'interno del casco.

Se senti un segnale acustico che indica una batteria scarica, ti preghiamo di caricare il dispositivo tempestivamente.

•Funzioni del telefono

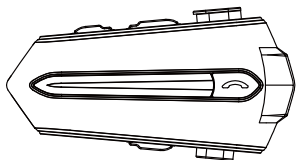

(Nessuna connessione Bluetooth)

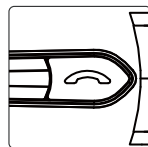

Passa alla modalità di ricezione

Modalità automatica (Ⓢattendi 10 secondi e poi rispondi automaticamente!)

Doppio clic sul pulsante di accensione per passare tra risposta manuale e automatica e tra risposta automatica

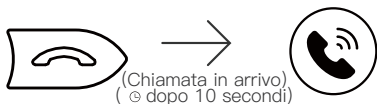

Automatico

Risposta automatica



Chiamata in arrivo
Rispondi manualmente

Rispondi

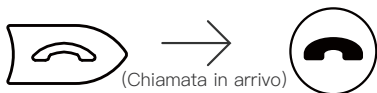

Tenere premuto
per 2 secondi

Rifuta

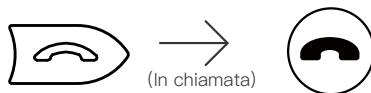

"Pressione breve"
Durante una chiamata

Termina la
chiamata

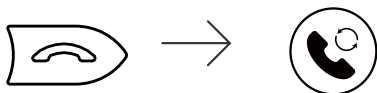

Doppio clic

Richiama l'ultimo numero

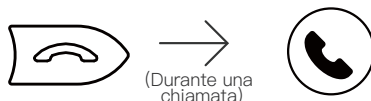

Pressione breve

Annulla la chiamata
in corso

● Accensione/spegnimento

► Accendere/spegnere l'alimentazione

Tre tocchi consecutivi per passare tra annunci vocali in cinese e inglese (Bluetooth disconnesso)

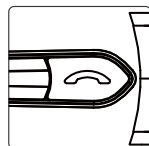
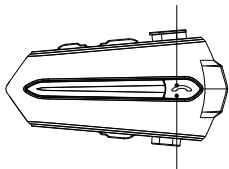

Il LED si accende

Tenere premuto per 3 secondi per accendere il dispositivo

● Accoppiamento

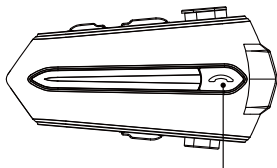

Bluetooth non connesso
Il LED lampeggia

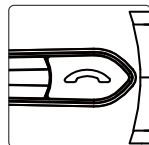

Bluetooth non connesso,
il LED lampeggia

● Acceso e spento

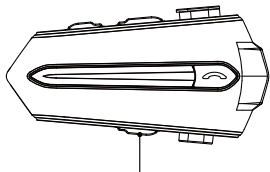

Stato di connessione del telefono: Doppio clic
Tasto vocale per cambiare modalità luce

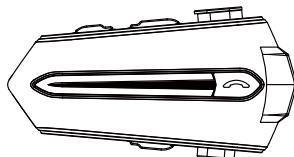

La luce è accesa

• Funzioni musicali

► Pausa/Riproduzione musica



(Stop della musica)

Premere brevemente



(Riproduzione della musica)

Riproduzione



Pausa

Tasto di diminuzione del volume

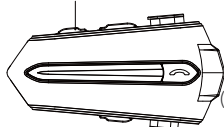

(Stop della musica)

Premere brevemente per la traccia precedente



(Riproduzione della musica)

Mantenere premuto per diminuire il volume



Tasto di aumento del volume

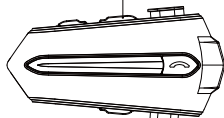

(Stop della musica)

Premere brevemente per la traccia successiva



(music playing)

Mantenere premuto per aumentare il volume



• Assistente vocale

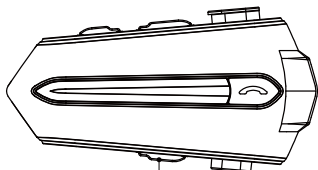

Tasto dell'assistente vocale

Premere brevemente



Attivazione dell'assistente vocale

• Modalità di carica

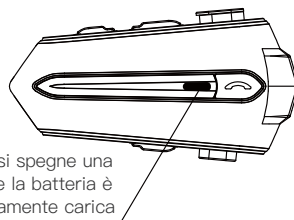
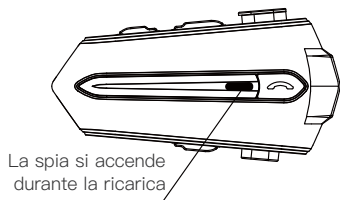

(Quando l'apparecchio è acceso, collegare il caricatore e l'apparecchio si spegnerà automaticamente)

• Elenco degli accessori

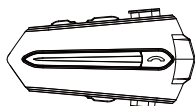

C5S*1

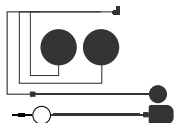

Cuffie e
microfono *1

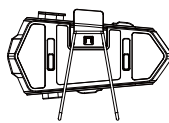

Base a
clip *1

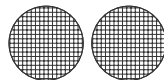

Nastro adesivo magico
per microfono *2

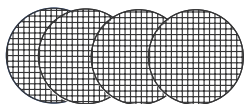

Nastro adesivo magico per
altoparlanti *4

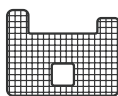

Nastro adesivo magico
per supporto *1



Nastro adesivo in doppia
faccia spesso *1



Nastro adesivo magico
per supporto *1

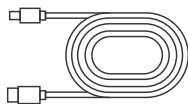

Cavo di ricarica *1



Manuale d'istruzioni *1

•Note

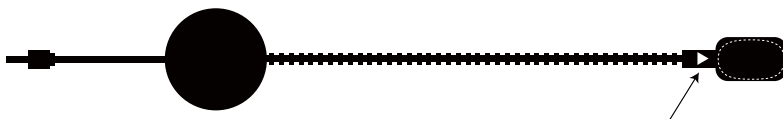

Per un'esperienza di chiamata di alta qualità, una volta installato il microfono rigido. Assicurati che i simboli < ► > siano allineati con la direzione della bocca, altrimenti potrebbero verificarsi rumori durante la chiamata.

Manual del usuario

| Visión general del producto

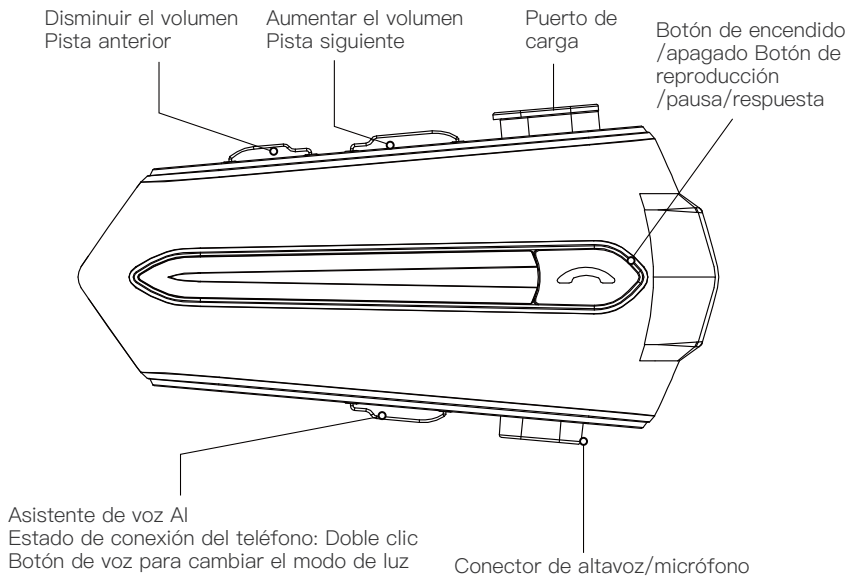

Consejos importantes:

Antes de conectar los auriculares, por favor, pruebe el volumen conectando su teléfono.

Si nota una gran diferencia de volumen después de instalar el casco, por favor, ajuste la posición adecuada de los altavoces dentro del casco.

Si escucha un tono de advertencia de batería baja, por favor, cargue el dispositivo rápidamente.

•Funciones del teléfono

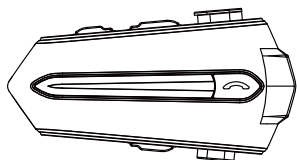

→
(Sin conexión Bluetooth)

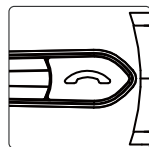

Cambiar al modo de recepción

Modo automático (☹ esperar 10 segundos y ¡luego responder automáticamente!)

Doble clic en el botón de encendido para cambiar entre respuesta manual y automática y entre respuesta automática

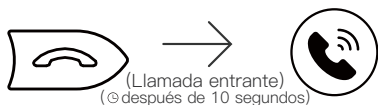

Automático

Respuesta automática



Llamada entrante
Responder manualmente

Responder



Mantén presionado durante 2 segundos

Rechazar

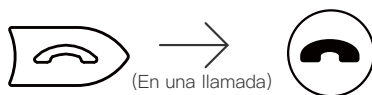

"Pulsación corta"
Durante una llamada

Finalizar llamada

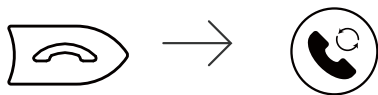

Doble clic

Volver a marcar el último número



Pulsación corta

Cancelar la llamada actual

● Encendido/apagado

▶ Encender/apagar el dispositivo

Tres toques consecutivos para cambiar entre anuncios de voz en chino e inglés (Bluetooth desconectado)

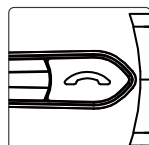
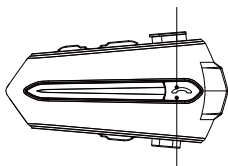

El LED se enciende

Mantén pulsado durante 3 segundos para encender el dispositivo

● Emparejamiento

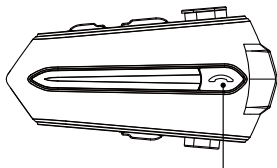

Bluetooth no conectado
El LED parpadea

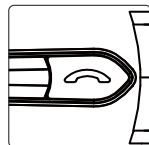

Bluetooth no conectado,
el LED parpadea

● Encendido y apagado

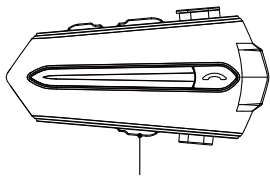

Estado de conexión del teléfono: Doble clic Botón vocal para cambiar el modo de luz

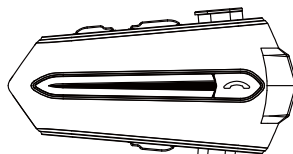

La luz está encendida

• Funciones de música

▶ Pausa/Reproducción de música



(Detener la música)

Pulsación corta



(Reproducción de música)

Reproducción



Pausa

Botón de disminución de volumen

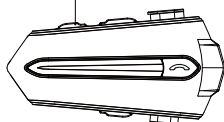

(Detener la música)



Pulsación corta para la canción anterior

(Reproducción de música)



Mantener pulsado para disminuir el volumen

Botón de aumento de volumen

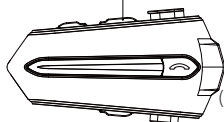

(Detener la música)

Pulsación corta para la próxima canción



(Reproducción de música)



Mantener pulsado para aumentar el volumen

• Asistente de voz

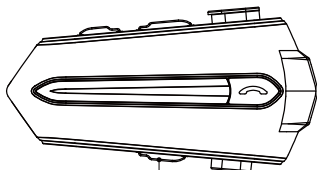

Botón del asistente de voz

→
Pulsación corta



Activación del asistente de voz

• Modo de carga

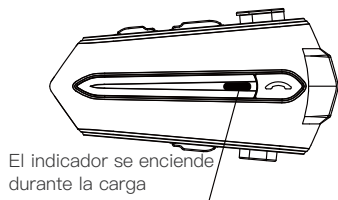

(Cuando el dispositivo está encendido, conecte el cargador y el dispositivo se apagará automáticamente)

• Lista de accesorios

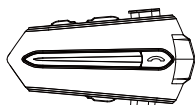

C5S*1

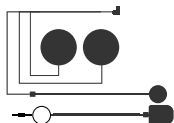

Auriculares y micrófono *1

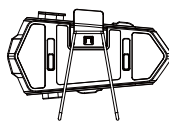

Base de pinza *1

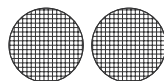

Cintas adhesivas mágicas para micrófono *2

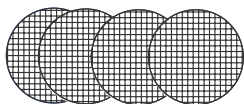

Cintas adhesivas mágicas para altavoces *4

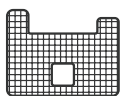

Cinta adhesiva mágica para soporte *1



Cinta adhesiva de doble cara gruesa *1



Cinta adhesiva mágica para soporte *1

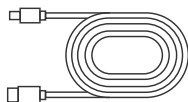

Cable de carga *1

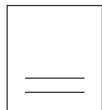

Manual de instrucciones *1

•Note

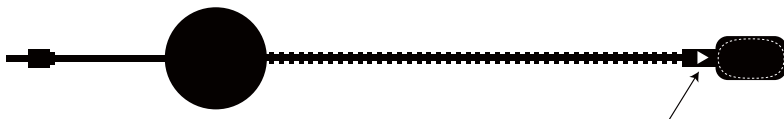

Para una experiencia de llamada de alta calidad, una vez instalado el micrófono rígido. Asegúrese de que los símbolos < ► > estén alineados con la dirección de la boca, de lo contrario puede haber ruidos durante la llamada.

ユーザーマニュアル

製品概要

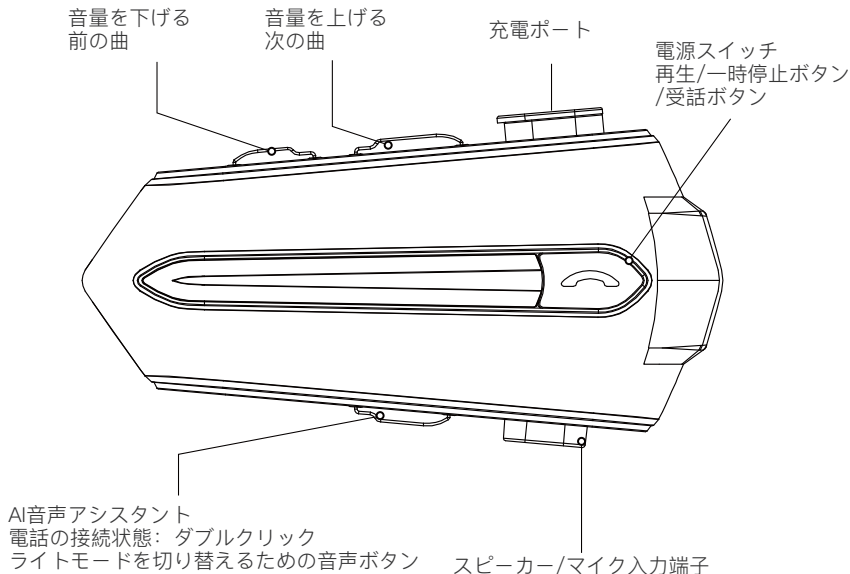

重要なお知らせ:

イヤホンを接続する前に、電話を接続して音量をテストしてください。

ヘルメットを取り付けた後、大きな音量の違いを感じた場合は、ヘルメット内のスピーカーの適切な位置を調整してください。

低電量の警告音が聞こえた場合は、すぐにデバイスを充電してください。

●電話機能

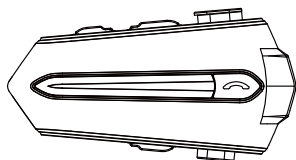

受信モードに切り替える

自動モード (Ⓞ10秒待ってその後、自動的に応答する!)

→
(Bluetoothが接続されていない)

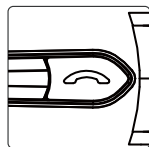

手動応答と自動応答
および自動応答の切り替えのために、
電源ボタンを2回クリックします



自動



(着信)
(Ⓞ10秒後)



自動応答



着信
手動で応答



(着信)



応答する



2秒間押し続ける



(着信)



拒否する



「短押し」
通話中



(通話中)



通話を終了する



ダブルクリック



最後の番号をリダイヤルする



短押し



(通話中)



現在の通話をキャン
セルする

●電源オン/オフ

▶電源を入れる/切る

3回の連続クリックで中国語と英語の
音声アナウンスを切り替える（
Bluetooth未接続）

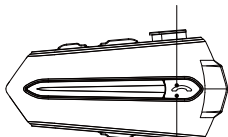

デバイスを3秒間長押ししてオンにする

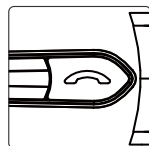

LEDが点灯します

●ペアリング

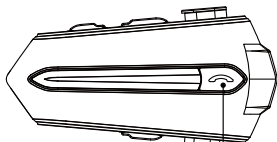

Bluetooth未接続
LEDが点滅します

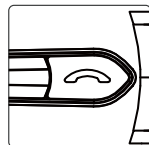

Bluetooth未接続、
LEDが点滅します

●オンとオフ

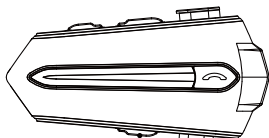

電話の接続状態：ダブルクリック
ライトモードを切り替えるための音声ボタン

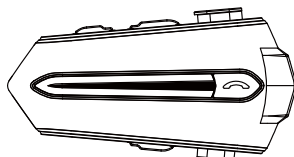

ライトが点灯します

●音楽機能

▶音楽の一時停止/再生



短押し



(音楽停止)



再生



(音楽再生)



一時停止

音量を下げるボタン

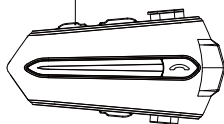

(音楽停止)



短押しで前の曲に戻る



(音楽再生)



音量を下げる
ために長押し

音量を上げるボタン

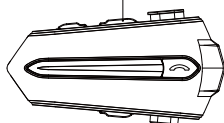

(音楽停止)



短押しで次の曲に進む



(音楽再生)



音量を上げるために長押し

●音声アシスタント

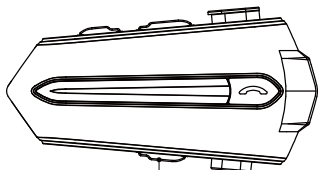

音声アシスタントボタン



短押し



音声アシスタントを起動

●充電モード

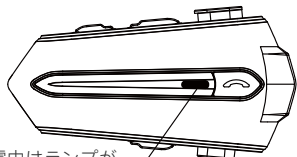

充電中はランプが点灯します

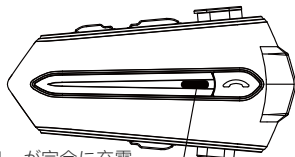

バッテリーが完全に充電されると、ランプが消えます

(デバイスがオンの場合、充電器を差し込むと、デバイスが自動的にシャットダウンします)

●アクセサリリスト

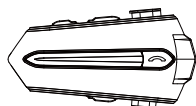

C5S*1

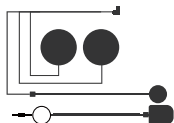

イヤホンとマイク*1

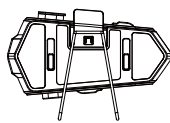

クリップ式ドッキングステーション*1

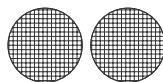

マイク用マジックテープ*2

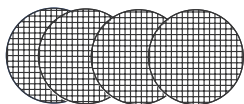

スピーカー用マジックテープ*4

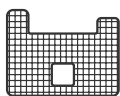

スタンド用マジックテープ*1



厚手の両面テープ*1



スタンド用マジックテープ*1

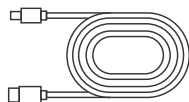

充電ケーブル*1



取扱説明書*1

●Note

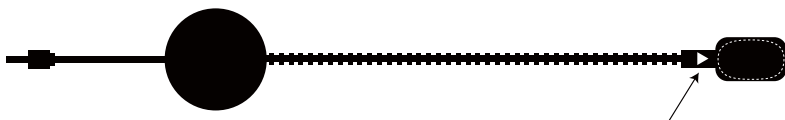

高品質な通話体験をお楽しみいただくために、ハードマイクをインストールした後は、<▶>記号が口の方向に揃っていることを確認してください。そうでないと、通話中にノイズが発生する可能性があります。

用户手册

产品概览

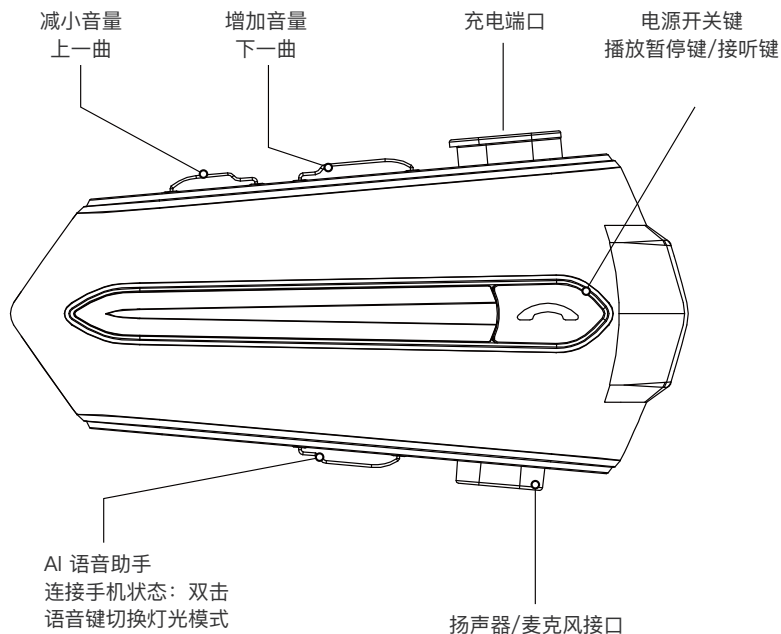

重要提示:

在安装耳机前, 请链接手机试听音量大小。

如安装到头盔后, 音量有较大差异, 请调整喇叭在头盔内部的合适位置。

但听到低电量提示音, 请及时给设备充电。

•手机功能

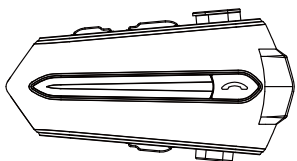

→
(未连接蓝牙时)

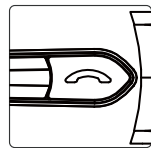

切换到接收模式

自动模式 (⊖ 等待 10 秒后自动接听)

双击电源按钮,在手动接听和自动接听之间切换和自动接听之间切换



自动



(来电)
(⊖ 10 秒后)



自动应答



来电
手动接听



(来电)



接听



按住2 秒钟



(来电)



拒绝接听



“短按”
通话中



(正在通话)



结束通话



双击



未号重播



短按



(通话继续时)



取消当前通话

●电源开启/关闭

▶ 打开/关闭电源

连续三击可切换中英文语音广播（断开蓝牙）

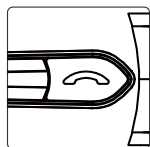
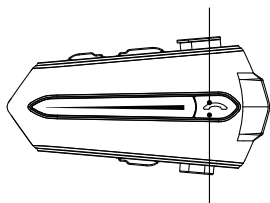

LED 灯亮

长按 3 秒打开设备

●配对

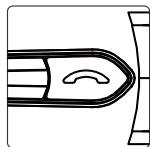
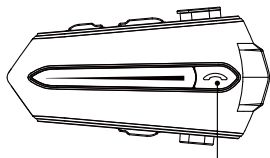

蓝牙未连接
LED 闪烁

蓝牙未连接 LED 闪烁

●亮起和熄灭

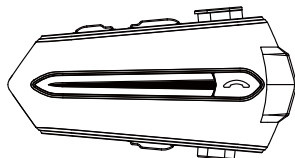
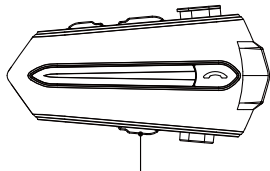

连接手机状态：双击
语音键切换灯光模式

灯亮

• 音乐功能

▶ 暂停/播放音乐



(音乐停止)

短按



播放



(音乐播放)



暂停

音量减小键

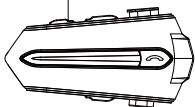

(音乐停止)



短按上一曲



(音乐播放)



长按调小音量

音量增大键

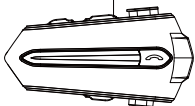

(音乐停止)



短按换下一曲



(音乐播放)



长按加大音量

• 语音助手

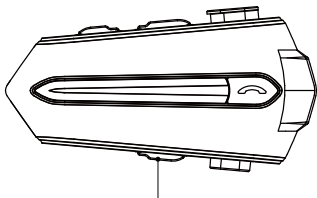

语音助手键



短按



唤醒语音助手

● 充电模式

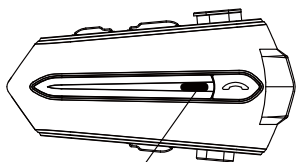

充电时指示灯亮起

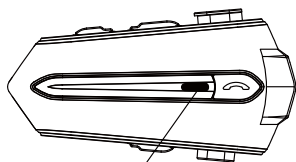

充满电后指示灯熄灭

(机器开启时，插入充电器，机器将自动关机)

● 配件列表

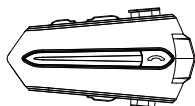

C5S*1

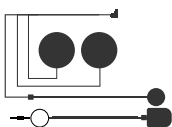

耳机和麦克风*1

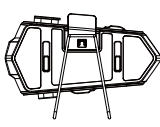

夹式底座*1

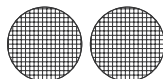

麦克风魔术贴*2

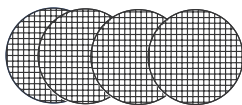

扬声器魔术贴*4

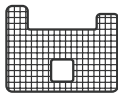

支架魔术贴*1



加厚双面胶*1



支架魔术贴*1

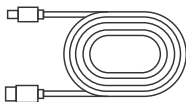

充电线*1

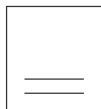

说明书*1

•Note

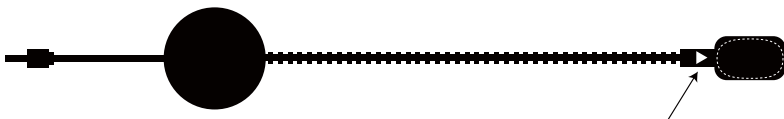

为体验高质量的通话效果，硬麦克风安装完成后。请确保< ▶ > 符号是否对准嘴巴方向，否则通话会有杂音

