

Test Report

Report No. : MTi250717026-0106E1

Date of issue : 2025-08-11

Applicant : Shenzhen Xiangdangwen Technology Co.,Ltd.

Product : W116 Magnetic Wireless Charger

Model(s) : 2E7179

FCC ID : 2AW73-2E7179

Shenzhen Microtest Co., Ltd.

TEST REPORT

Report No.: MTi250717026-0106E1

Table of contents

1	General Description	4
1.1	Description of the EUT	4
1.2	Description of test modes	4
1.3	Environmental Conditions	5
1.4	Description of support units	5
1.5	Measurement uncertainty	5
2	Summary of Test Result	6
3	Test Facilities and accreditations	7
3.1	Test laboratory	7
4	List of test equipment	8
5	Evaluation Results (Evaluation)	9
5.1	Antenna requirement	9
6	Radio Spectrum Matter Test Results (RF)	10
6.1	Conducted Emission at AC power line	10
6.2	20dB Occupied Bandwidth	13
6.3	Emissions in frequency bands (below 30MHz)	17
6.4	Emissions in frequency bands (30MHz - 1GHz)	22
	Photographs of the test setup	26
	Photographs of the EUT	27

TEST REPORT

Report No.: MTi250717026-0106E1

Test Result Certification		
Applicant	Shenzhen Xiangdangwen Technology Co.,Ltd.	
Applicant Address	10E-03, Building 1#, Shenzhen International South China Digital Valley, Minxin Community, Minzhi Street, Longhua District, Shenzhen City, Guangdong Province, China	
Manufacturer	Shenzhen Xiangdangwen Technology Co.,Ltd.	
Manufacturer Address	10E-03, Building 1#, Shenzhen International South China Digital Valley, Minxin Community, Minzhi Street, Longhua District, Shenzhen City, Guangdong Province, China	
Product description		
Product name	W116 Magnetic Wireless Charger	
Trademark	LISEN, AINOPE, VEICO	
Model name	2E7179	
Series Model(s)	N/A	
Standards	47 CFR Part 15C	
Test Method	ANSI C63.10-2013	
Testing Information		
Date of test	2025-07-18 to 2025-08-06	
Test result	Pass	
Prepared by:	Yanice.Xie	<i>Yanice Xie</i>
Reviewed by:	David Lee	<i>David. Lee</i>
Approved by:	Lewis Lian	<i>Lewis Lian</i>

TEST REPORT

Report No.: MTi250717026-0106E1

1 General Description

1.1 Description of the EUT

Product name:	W116 Magnetic Wireless Charger
Model name:	2E7179
Series Model(s):	N/A
Model difference:	N/A
Electrical rating:	Input:5V=3A, 9V=3A, 12V=3A, 15V=3A Output:5W/7.5W/10W/15W/25W
Accessories:	Cable: USB-C toUSB-C 1m
Hardware version:	V1
Software version:	V1
Test sample(s) number:	MTi250717026-01-R001
RF specification	
Operating frequency range:	115-205kHz(5W-10W)&360kHz(MPP 15W-25W)
Modulation type:	ASK
Antenna(s) type:	Coil

1.2 Description of test modes

No.	Emission test modes
Mode1	Wireless outout(5W)
Mode2	Wireless outout(7.5W)
Mode3	Wireless outout(10W)
Mode4	Wireless outout(MPP15W)
Mode5	Wireless outout(25W)
Mode6	Standby

TEST REPORT

Report No.: MTi250717026-0106E1

1.3 Environmental Conditions

During the measurement the environmental conditions were within the listed ranges:

Temperature:	15°C ~ 35°C
Humidity:	20% RH ~ 75% RH
Atmospheric pressure:	98 kPa ~ 101 kPa

1.4 Description of support units

The EUT has been tested as an independent unit together with other necessary accessories or support units. The following support units or accessories were used to form a representative test configuration during the tests.

Support equipment list

Description	Model	Serial No.	Manufacturer
wireless charging load	YBZ3.0	/	YBZ
wireless charging load	YBZ2.1	/	YBZ
HUAWEI QUICK CHARGE(65W)	HW-200325CP1	FL8606P8500764	HUAWEI

Support cable list

Description	Length (m)	From	To
/	/	/	/

1.5 Measurement uncertainty

Measurement	Uncertainty
Conducted emissions (AMN 150kHz~30MHz)	±3.1dB
Occupied channel bandwidth	±3 %
Radiated spurious emissions (9kHz~30MHz)	±4.3dB
Radiated spurious emissions (30MHz~1GHz)	±4.7dB
Temperature	±1 °C
Humidity	± 5 %

This uncertainty represents an expanded uncertainty expressed at approximately the 95% confidence level using a coverage factor of k=2.

TEST REPORT

Report No.: MTi250717026-0106E1

2 Summary of Test Result

No.	Item	Standard	Requirement	Result
1	Antenna requirement	47 CFR Part 15C	47 CFR Part 15.203	Pass
2	Conducted Emission at AC power line	47 CFR Part 15C	47 CFR Part 15.207(a)	Pass
3	20dB Occupied Bandwidth	47 CFR Part 15C	47 CFR Part 15.215(c)	Pass
4	Emissions in frequency bands (below 30MHz)	47 CFR Part 15C	47 CFR Part 15.209	Pass
5	Emissions in frequency bands (30MHz - 1GHz)	47 CFR Part 15C	47 CFR Part 15.209	Pass

TEST REPORT

Report No.: MTi250717026-0106E1

3 Test Facilities and accreditations

3.1 Test laboratory

Test laboratory:	Shenzhen Microtest Co., Ltd.
Test site location:	101, No.7, Zone 2, Xinxing Industrial Park, Fuhai Avenue, Xinhe Community, Fuhai Street, Bao'an District, Shenzhen, Guangdong, China
Telephone:	(86-755)88850135
Fax:	(86-755)88850136
CNAS Registration No.:	CNAS L5868
FCC Registration No.:	448573
IC Registration No.:	21760
CABID:	CN0093

TEST REPORT

Report No.: MTi250717026-0106E1

4 List of test equipment

No.	Equipment	Manufacturer	Model	Serial No.	Cal. date	Cal. Due
Conducted Emission at AC power line						
1	EMI Test Receiver	Rohde&schwarz	ESCI3	101368	2025-03-14	2026-03-13
2	Artificial mains network	Schwarzbeck	NSLK 8127	183	2025-03-18	2026-03-17
3	Artificial Mains Network	Rohde & Schwarz	ESH2-Z5	100263	2025-03-18	2026-03-17
20dB Occupied Bandwidth						
1	Wideband Radio Communication Tester	Rohde&schwarz	CMW500	149155	2025-03-18	2026-03-17
2	ESG Series Analog Ssignal Generator	Agilent	E4421B	GB40051240	2025-03-14	2026-03-13
3	PXA Signal Analyzer	Agilent	N9030A	MY51350296	2025-03-14	2026-03-13
4	Synthesized Sweeper	Agilent	83752A	3610A01957	2025-03-14	2026-03-13
5	MXA Signal Analyzer	Agilent	N9020A	MY50143483	2025-03-14	2026-03-13
6	RF Control Unit	Tonscend	JS0806-1	19D8060152	2025-03-18	2026-03-17
7	Band Reject Filter Group	Tonscend	JS0806-F	19D8060160	2025-03-14	2026-03-13
8	ESG Vector Signal Generator	Agilent	N5182A	MY50143762	2025-03-14	2026-03-13
9	DC Power Supply	Agilent	E3632A	MY40027695	2025-03-18	2026-03-17
Emissions in frequency bands (below 30MHz)						
1	EMI Test Receiver	Rohde&schwarz	ESCI7	101166	2025-03-14	2026-03-13
2	Active Loop Antenna	Schwarzbeck	FMZB 1519 B	00066	2024-03-23	2026-03-22
3	Amplifier	Hewlett-Packard	8447F	3113A06184	2025-03-18	2026-03-17
Emissions in frequency bands (30MHz - 1GHz)						
1	EMI Test Receiver	Rohde&schwarz	ESCI7	101166	2025-03-14	2026-03-13
2	TRILOG Broadband Antenna	schwarabeck	VULB 9163	9163-1338	2025-05-23	2027-05-22
3	Active Loop Antenna	Schwarzbeck	FMZB 1519 B	00066	2024-03-23	2026-03-22
4	Amplifier	Hewlett-Packard	8447F	3113A06184	2025-03-18	2026-03-17

TEST REPORT

Report No.: MTi250717026-0106E1

5 Evaluation Results (Evaluation)

5.1 Antenna requirement

Test Requirement:	Refer to 47 CFR Part 15.203, an intentional radiator shall be designed to ensure that no antenna other than that furnished by the responsible party shall be used with the device. The use of a permanently attached antenna or of an antenna that uses a unique coupling to the intentional radiator shall be considered sufficient to comply with the provisions of this section.
-------------------	---

5.1.1 Conclusion:

The antenna of the EUT is permanently attached.
The EUT complies with the requirement of FCC PART 15.203.

TEST REPORT

Report No.: MTi250717026-0106E1

6 Radio Spectrum Matter Test Results (RF)

6.1 Conducted Emission at AC power line

Test Requirement:	Except as shown in paragraphs (b) and (c) of this section, for an intentional radiator that is designed to be connected to the public utility (AC) power line, the radio frequency voltage that is conducted back onto the AC power line on any frequency or frequencies, within the band 150 kHz to 30 MHz, shall not exceed the limits in the following table, as measured using a 50 μ H/50 ohms line impedance stabilization network (LISN).		
Test Limit:	Frequency of emission (MHz)	Conducted limit (dB μ V)	
		Quasi-peak	Average
	0.15-0.5	66 to 56*	56 to 46*
	0.5-5	56	46
	5-30	60	50
	*Decreases with the logarithm of the frequency.		
Test Method:	ANSI C63.10-2013 section 6.2		
Procedure:	Refer to ANSI C63.10-2013 section 6.2, standard test method for ac power-line conducted emissions from unlicensed wireless devices		

6.1.1 E.U.T. Operation:

Operating Environment:			
Temperature:	26 °C	Humidity:	66 %
		Atmospheric Pressure:	100 kPa
Pre test mode:	Mode1, Mode2, Mode3, Mode4, Mode5, Mode6		
Final test mode:	All of the listed pre-test mode were tested, only the data of the worst mode (Mode4) is recorded in the report		

6.1.2 Test Setup Diagram:

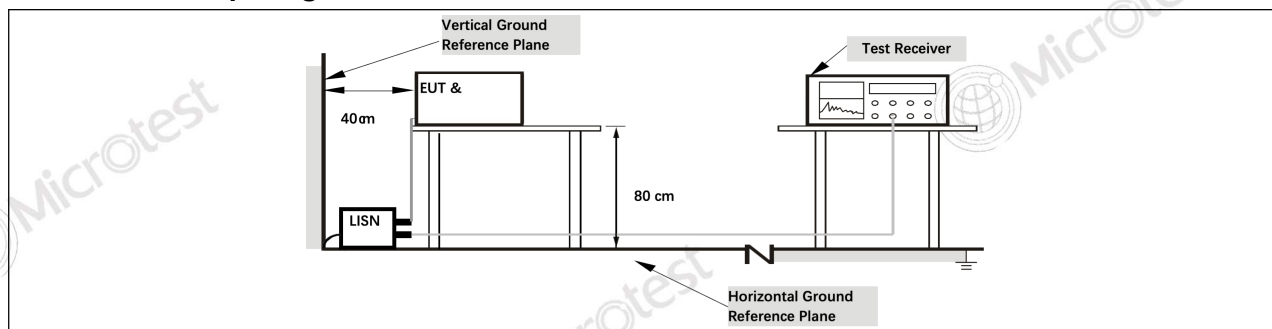

TEST REPORT

Report No.: MTi250717026-0106E1

6.1.3 Test Data:

Mode4 / Line: Line

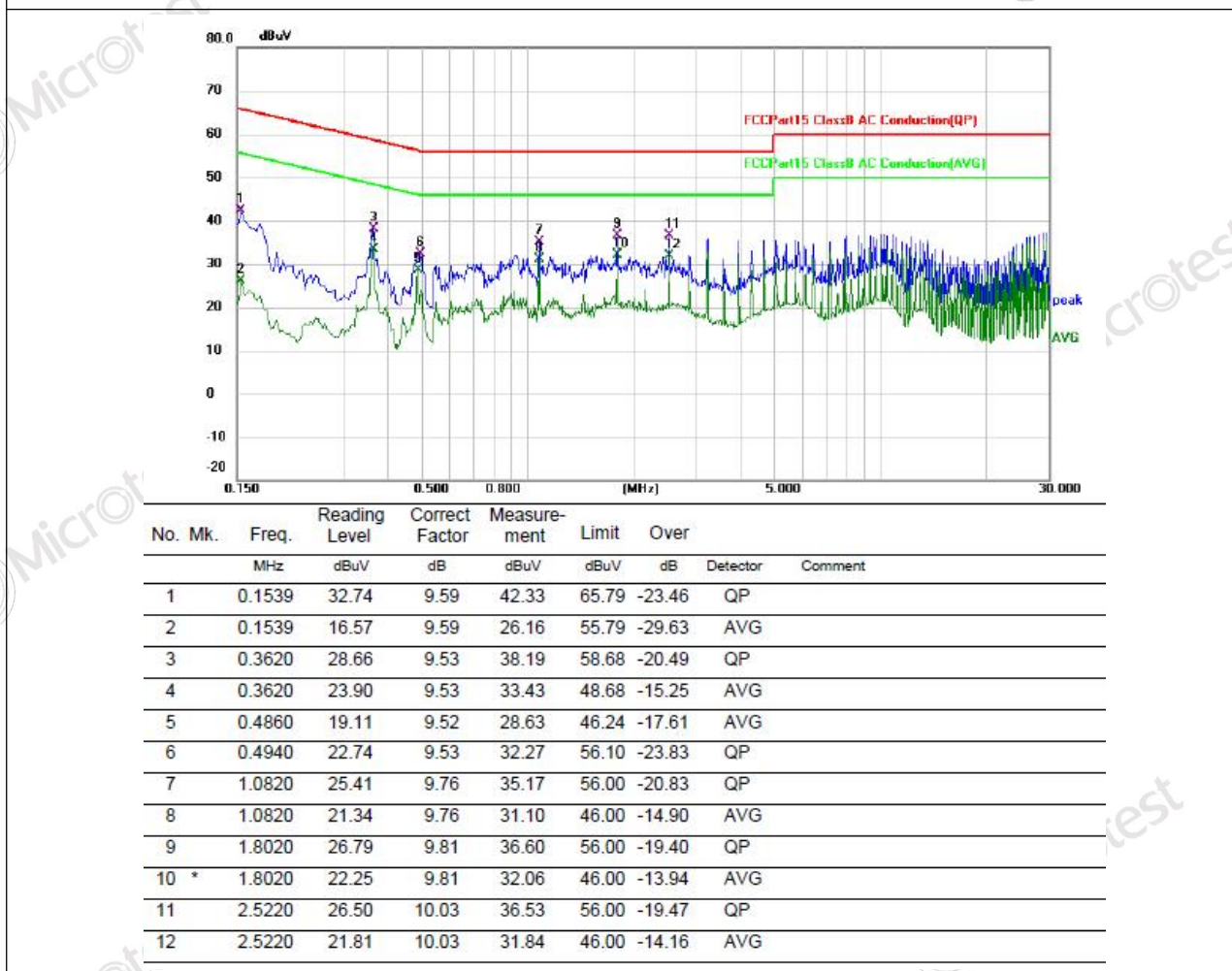

TEST REPORT

Report No.: MTi250717026-0106E1

Mode4 / Line: Neutral

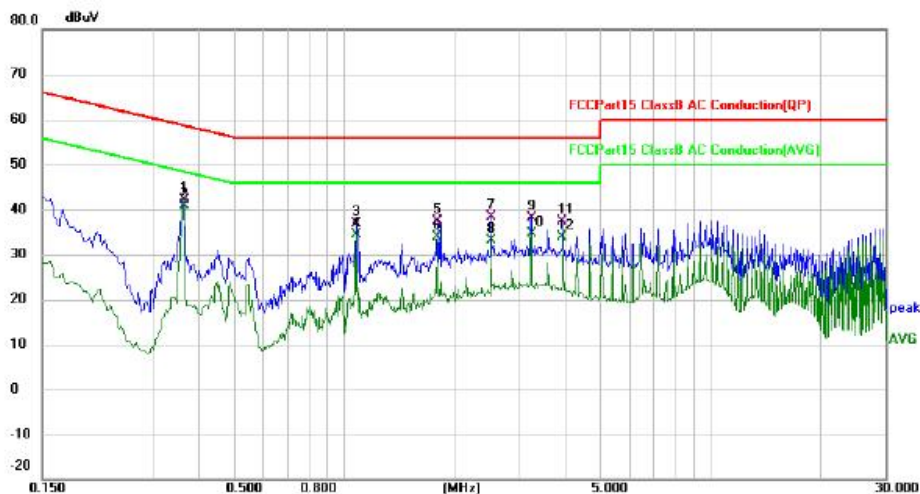

No.	Mk.	Freq. MHz	Reading Level dBuV	Correct Factor dB	Measure- ment dBuV	Limit dBuV	Over dB	Detector	Comment
1		0.3620	32.37	9.74	42.11	58.68	-16.57	QP	
2	*	0.3620	31.26	9.74	41.00	48.68	-7.68	AVG	
3		1.0820	27.20	9.79	36.99	56.00	-19.01	QP	
4		1.0820	24.71	9.79	34.50	46.00	-11.50	AVG	
5		1.8020	27.61	9.80	37.41	56.00	-18.59	QP	
6		1.8020	24.10	9.80	33.90	46.00	-12.10	AVG	
7		2.5220	28.61	9.84	38.45	56.00	-17.55	QP	
8		2.5220	23.39	9.84	33.23	46.00	-12.77	AVG	
9		3.2420	28.25	9.87	38.12	56.00	-17.88	QP	
10		3.2420	24.72	9.87	34.59	46.00	-11.41	AVG	
11		3.9620	27.23	10.03	37.26	56.00	-18.74	QP	
12		3.9620	23.88	10.03	33.91	46.00	-12.09	AVG	

TEST REPORT

Report No.: MTi250717026-0106E1

6.2 20dB Occupied Bandwidth

Test Requirement:	47 CFR Part 15.215(c)
Test Limit:	Refer to 47 CFR 15.215(c), intentional radiators operating under the alternative provisions to the general emission limits, as contained in §§ 15.217 through 15.257 and in subpart E of this part, must be designed to ensure that the 20 dB bandwidth of the emission, or whatever bandwidth may otherwise be specified in the specific rule section under which the equipment operates, is contained within the frequency band designated in the rule section under which the equipment is operated.
Test Method:	ANSI C63.10-2013, section 6.9.2
Procedure:	<p>a) The spectrum analyzer center frequency is set to the nominal EUT channel center frequency. The span range for the EMI receiver or spectrum analyzer shall be between two times and five times the OBW.</p> <p>b) The nominal IF filter bandwidth (3 dB RBW) shall be in the range of 1% to 5% of the OBW and video bandwidth (VBW) shall be approximately three times RBW, unless otherwise specified by the applicable requirement.</p> <p>c) Set the reference level of the instrument as required, keeping the signal from exceeding the maximum input mixer level for linear operation. In general, the peak of the spectral envelope shall be more than $[10 \log (OBW/RBW)]$ below the reference level. Specific guidance is given in 4.1.5.2.</p> <p>d) Steps a) through c) might require iteration to adjust within the specified tolerances.</p> <p>e) The dynamic range of the instrument at the selected RBW shall be more than 10 dB below the target “-xx dB down” requirement; that is, if the requirement calls for measuring the -20 dB OBW, the instrument noise floor at the selected RBW shall be at least 30 dB below the reference value.</p> <p>f) Set detection mode to peak and trace mode to max hold.</p> <p>g) Determine the reference value: Set the EUT to transmit an unmodulated carrier or modulated signal, as applicable. Allow the trace to stabilize. Set the spectrum analyzer marker to the highest level of the displayed trace (this is the reference value).</p> <p>h) Determine the “-xx dB down amplitude” using $[(\text{reference value}) - xx]$. Alternatively, this calculation may be made by using the marker-delta function of the instrument.</p> <p>i) If the reference value is determined by an unmodulated carrier, then turn the EUT modulation ON, and either clear the existing trace or start a new trace on the spectrum analyzer and allow the new trace to stabilize. Otherwise, the trace from step g) shall be used for step j).</p> <p>j) Place two markers, one at the lowest frequency and the other at the highest frequency of the envelope of the spectral display, such that each marker is at or slightly below the “-xx dB down amplitude” determined in step h). If a marker is below this “-xx dB down amplitude” value, then it shall be as close as possible to this value. The occupied bandwidth is the frequency difference between the two markers. Alternatively, set a marker at the lowest frequency of the envelope of the spectral display, such that the marker is at or slightly below the “-xx dB down amplitude” determined in step h). Reset the marker-delta function and move the marker to the other side of the emission until the delta marker amplitude is at the same level as the reference marker amplitude. The marker-delta frequency reading at this point is the specified emission bandwidth.</p> <p>k) The occupied bandwidth shall be reported by providing plot(s) of the</p>

TEST REPORT

Report No.: MTi250717026-0106E1

	measuring instrument display; the plot axes and the scale units per division shall be clearly labeled. Tabular data may be reported in addition to the plot(s).
--	---

6.2.1 E.U.T. Operation:

Operating Environment:					
Temperature:	25.6 °C	Humidity:	61 %	Atmospheric Pressure:	101 kPa
Pre test mode:	Mode1, Mode2, Mode3, Mode4, Mode5, Mode6				
Final test mode:	All of the listed pre-test mode were tested, only the data of the worst mode (Mode3, Mode6) is recorded in the report				

6.2.2 Test Setup Diagram:

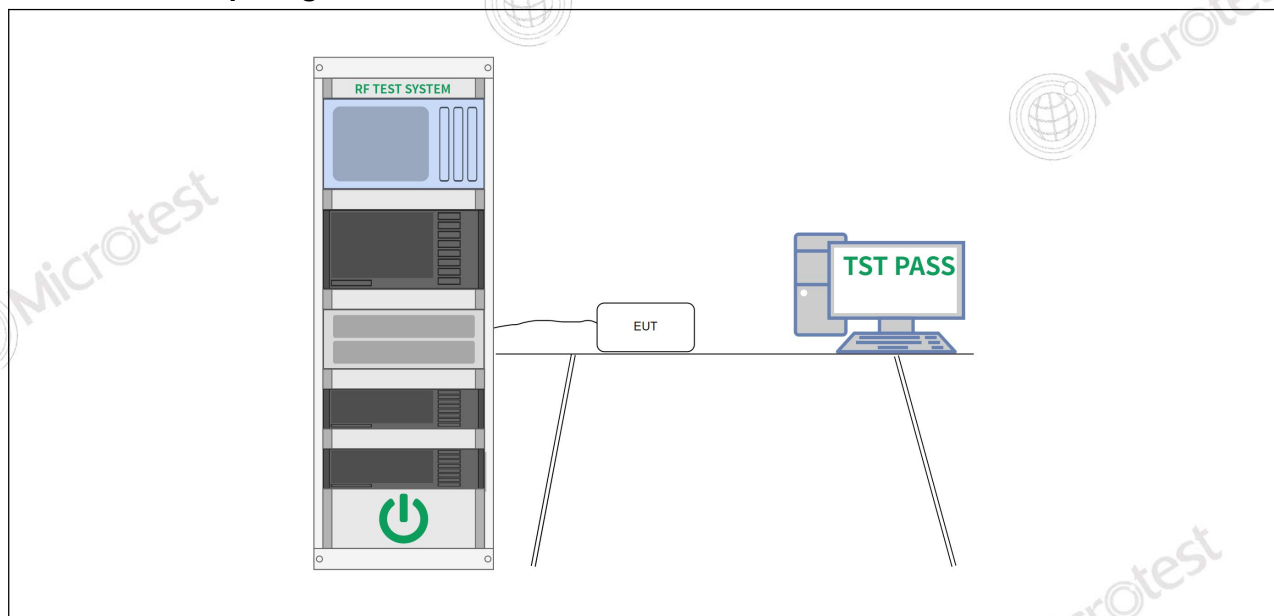

TEST REPORT

Report No.: MTi250717026-0106E1

6.2.3 Test Data:

Note: Because the measured signal is CW-like, adjusting the RBW per C63.10 would not be practical since measurement bandwidth will always follow the RBW. The RBW is set to 300 Hz to perform the occupied bandwidth test.

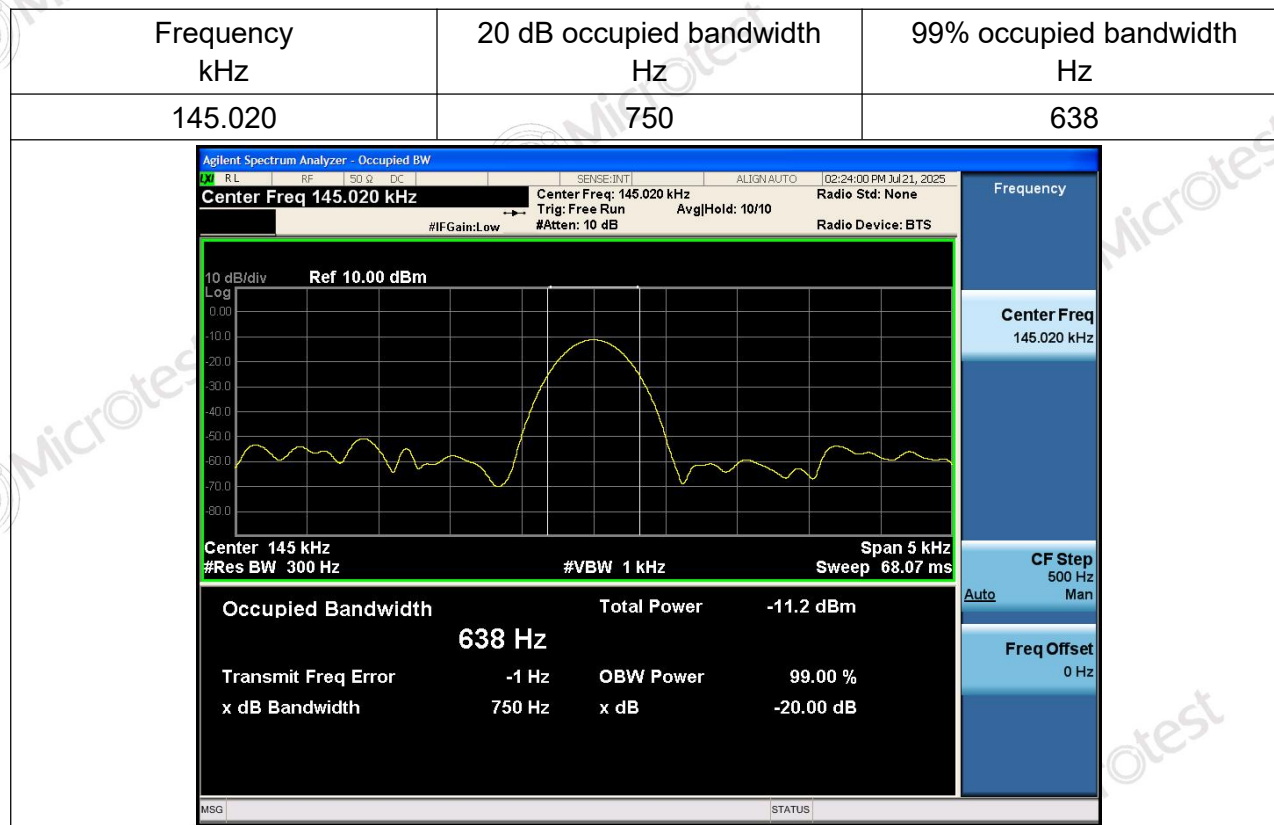

TEST REPORT

Report No.: MTi250717026-0106E1

Note: Because the measured signal is CW-like, adjusting the RBW per C63.10 would not be practical since measurement bandwidth will always follow the RBW. The RBW is set to 300 Hz to perform the occupied bandwidth test.

Frequency kHz	20 dB occupied bandwidth Hz	99% occupied bandwidth Hz
360	764	694

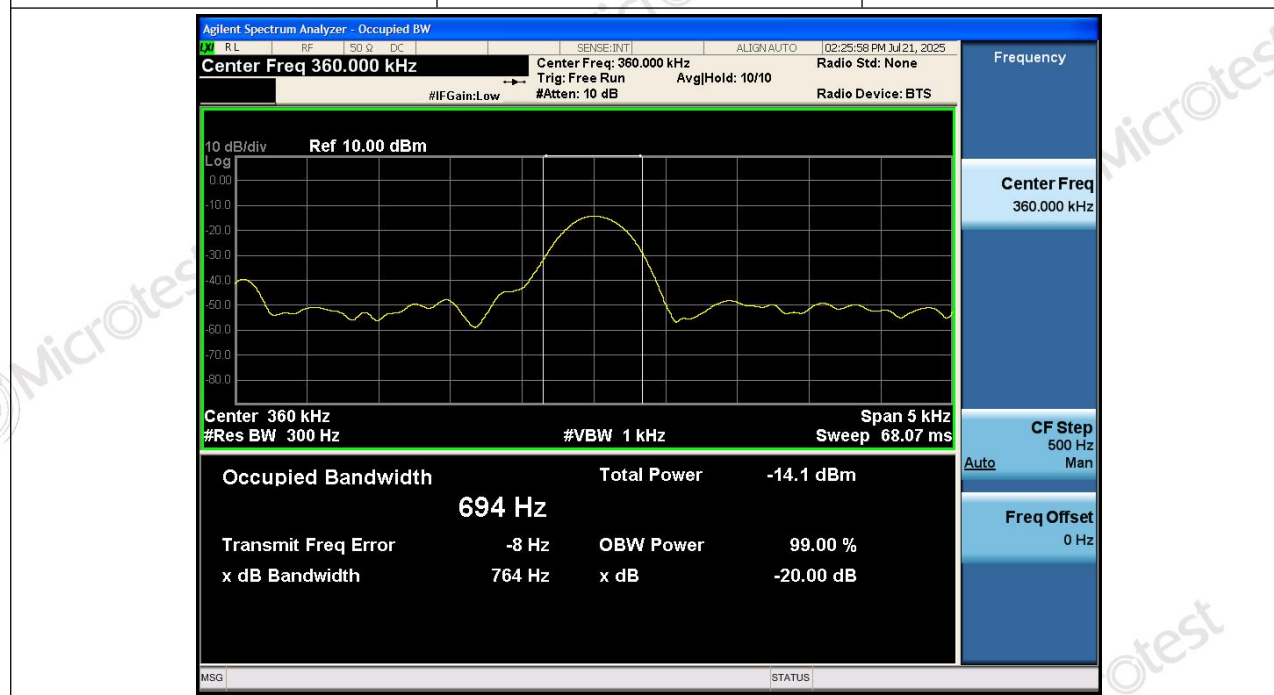

TEST REPORT

Report No.: MTi250717026-0106E1

6.3 Emissions in frequency bands (below 30MHz)

Test Requirement:	47 CFR Part 15.209		
Test Limit:	Frequency (MHz)	Field strength (microvolts/meter)	Measurement distance (meters)
	0.009-0.490	2400/F(kHz)	300
	0.490-1.705	24000/F(kHz)	30
	1.705-30.0	30	30
	30-88	100 **	3
	88-216	150 **	3
	216-960	200 **	3
	Above 960	500	3
<p>** Except as provided in paragraph (g), fundamental emissions from intentional radiators operating under this section shall not be located in the frequency bands 54-72 MHz, 76-88 MHz, 174-216 MHz or 470-806 MHz. However, operation within these frequency bands is permitted under other sections of this part, e.g., §§ 15.231 and 15.241.</p> <p>In the emission table above, the tighter limit applies at the band edges.</p> <p>The emission limits shown in the above table are based on measurements employing a CISPR quasi-peak detector except for the frequency bands 9–90 kHz, 110–490 kHz and above 1000 MHz. Radiated emission limits in these three bands are based on measurements employing an average detector.</p> <p>As shown in § 15.35(b), for frequencies above 1000 MHz, the field strength limits in paragraphs (a) and (b) of this section are based on average limits. However, the peak field strength of any emission shall not exceed the maximum permitted average limits specified above by more than 20 dB under any condition of modulation. For point-to-point operation under paragraph (b) of this section, the peak field strength shall not exceed 2500 millivolts/meter at 3 meters along the antenna azimuth.</p>			
Test Method:	ANSI C63.10-2013 section 6.4		
Procedure:	ANSI C63.10-2013 section 6.4		

6.3.1 E.U.T. Operation:

Operating Environment:					
Temperature:	21 °C	Humidity:	53 %	Atmospheric Pressure:	101 kPa
Pre test mode:	Mode1, Mode2, Mode3, Mode4, Mode5, Mode6				
Final test mode:	All of the listed pre-test mode were tested, only the data of the worst mode (Mode3, Mode5) is recorded in the report				

6.3.2 Test Setup Diagram:

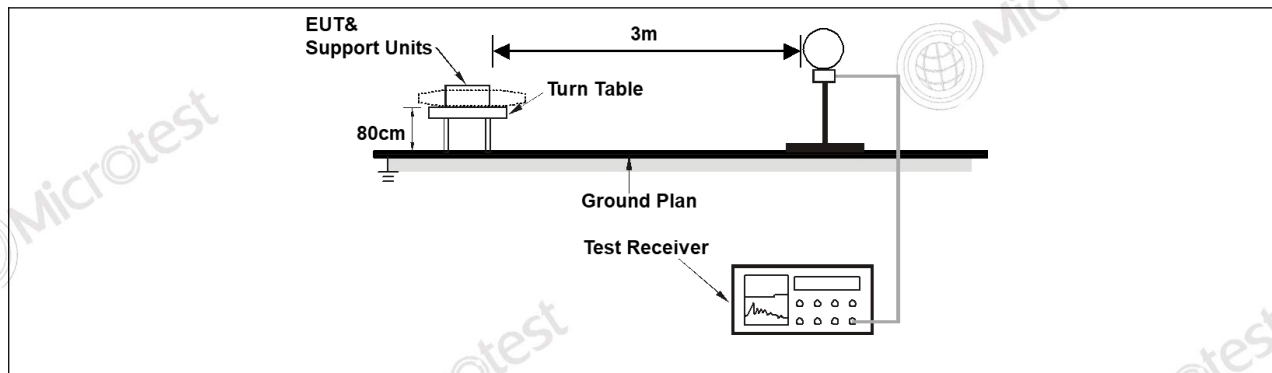

TEST REPORT

Report No.: MTi250717026-0106E1

6.3.3 Test Data:

Mode3 / EUT direction: X axis

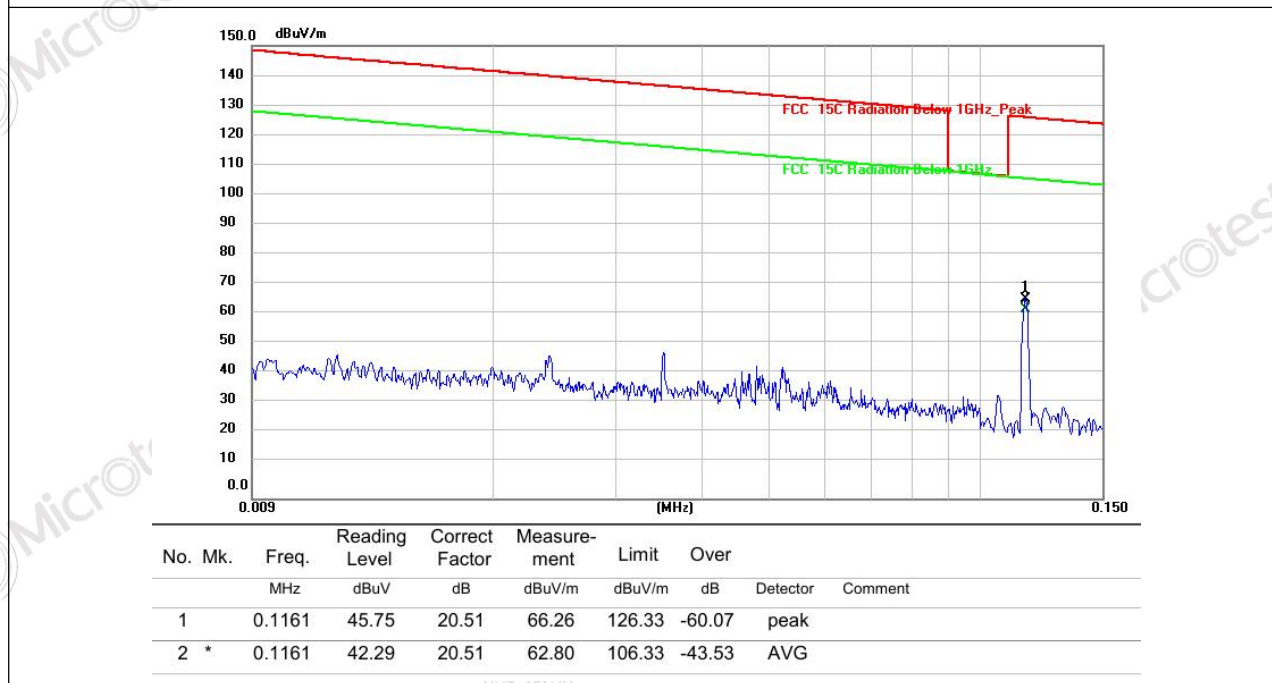

TEST REPORT

Report No.: MTi250717026-0106E1

Mode3 / EUT direction: X axis

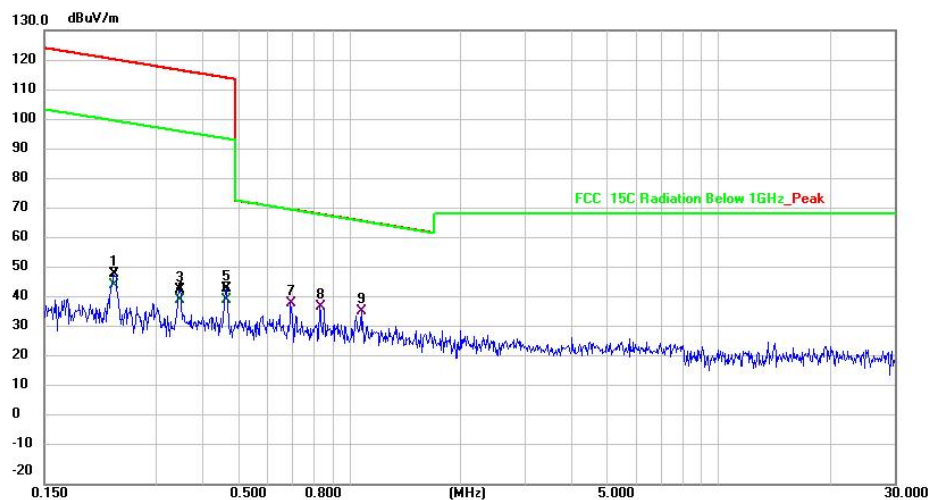

No.	Mk.	Freq. MHz	Reading Level dBuV	Correct Factor dB	Measure- ment dBuV/m	Limit dBuV/m	Over dB	Detector	Comment
1		0.2304	28.67	20.78	49.45	120.37	-70.92	peak	
2		0.2304	24.92	20.78	45.70	100.37	-54.67	AVG	
3		0.3465	23.22	21.06	44.28	116.82	-72.54	peak	
4		0.3465	19.94	21.06	41.00	96.82	-55.82	AVG	
5		0.4661	23.24	21.33	44.57	114.23	-69.66	peak	
6		0.4661	19.47	21.33	40.80	94.23	-53.43	AVG	
7		0.6936	18.02	21.86	39.88	70.79	-30.91	QP	
8		0.8305	16.36	22.19	38.55	69.23	-30.68	QP	
9	*	1.0766	14.51	22.76	37.27	66.98	-29.71	QP	

TEST REPORT

Report No.: MTi250717026-0106E1

Mode5 / EUT direction: X axis

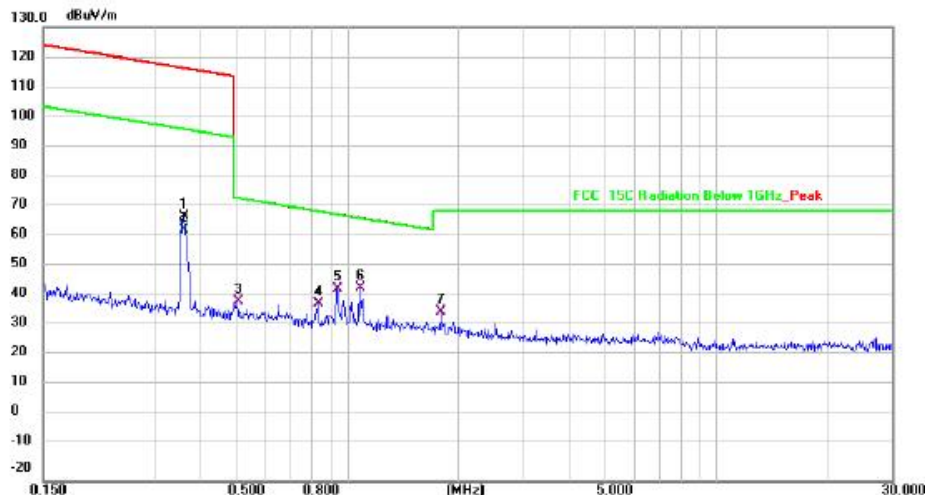

No.	Mk.	Freq. MHz	Reading Level dBuV	Correct Factor dB	Measure- ment dBuV/m	Limit dBuV/m	Over dB	Detector	Comment
1		0.3599	46.33	21.08	67.41	116.49	-49.08	peak	
2		0.3599	42.12	21.08	63.20	96.49	-33.29	AVG	
3		0.5047	17.97	21.40	39.37	73.54	-34.17	QP	
4		0.8305	16.52	22.19	38.71	69.23	-30.52	QP	
5		0.9381	21.01	22.46	43.47	68.17	-24.70	QP	
6	*	1.0824	21.00	22.76	43.76	66.94	-23.18	QP	
7		1.8000	11.99	24.24	36.23	69.50	-33.27	QP	

TEST REPORT

Report No.: MTi250717026-0106E1

Mode5 / EUT direction: X axis

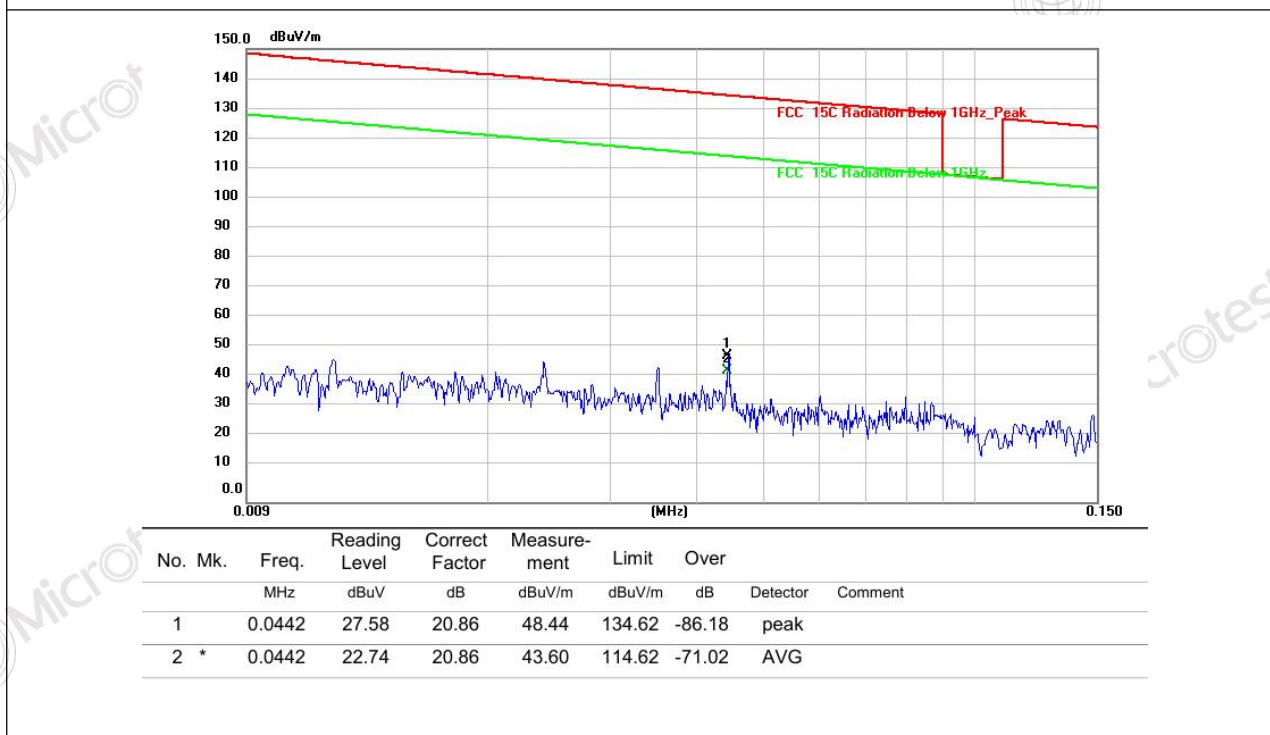

TEST REPORT

Report No.: MTi250717026-0106E1

6.4 Emissions in frequency bands (30MHz - 1GHz)

Test Requirement:	47 CFR Part 15.209		
Test Limit:	Frequency (MHz)	Field strength (microvolts/meter)	Measurement distance (meters)
	0.009-0.490	2400/F(kHz)	300
	0.490-1.705	24000/F(kHz)	30
	1.705-30.0	30	30
	30-88	100 **	3
	88-216	150 **	3
	216-960	200 **	3
	Above 960	500	3
<p>** Except as provided in paragraph (g), fundamental emissions from intentional radiators operating under this section shall not be located in the frequency bands 54-72 MHz, 76-88 MHz, 174-216 MHz or 470-806 MHz. However, operation within these frequency bands is permitted under other sections of this part, e.g., §§ 15.231 and 15.241.</p> <p>In the emission table above, the tighter limit applies at the band edges. The emission limits shown in the above table are based on measurements employing a CISPR quasi-peak detector except for the frequency bands 9–90 kHz, 110–490 kHz and above 1000 MHz. Radiated emission limits in these three bands are based on measurements employing an average detector. As shown in § 15.35(b), for frequencies above 1000 MHz, the field strength limits in paragraphs (a) and (b) of this section are based on average limits. However, the peak field strength of any emission shall not exceed the maximum permitted average limits specified above by more than 20 dB under any condition of modulation. For point-to-point operation under paragraph (b) of this section, the peak field strength shall not exceed 2500 millivolts/meter at 3 meters along the antenna azimuth.</p>			
Test Method:	ANSI C63.10-2013 section 6.5		
Procedure:	ANSI C63.10-2013 section 6.5		

6.4.1 E.U.T. Operation:

Operating Environment:					
Temperature:	21 °C	Humidity:	53 %	Atmospheric Pressure:	101 kPa
Pre test mode:	Mode1, Mode2, Mode3, Mode4, Mode5, Mode6				
Final test mode:	All of the listed pre-test mode were tested, only the data of the worst mode (Mode5) is recorded in the report				

6.4.2 Test Setup Diagram:

--

TEST REPORT

Report No.: MTi250717026-0106E1

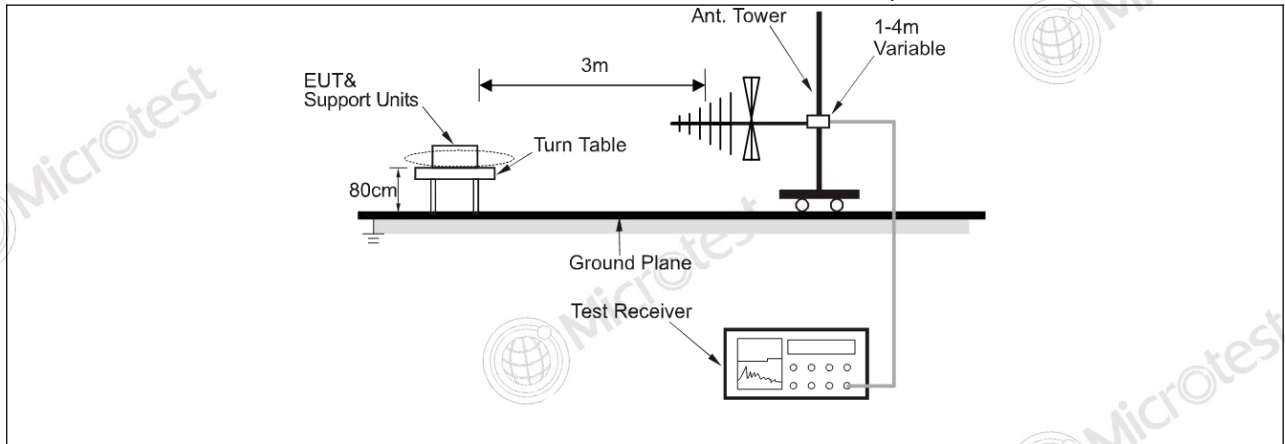

TEST REPORT

Report No.: MTi250717026-0106E1

6.4.3 Test Data:

Mode5 / Polarization: Horizontal

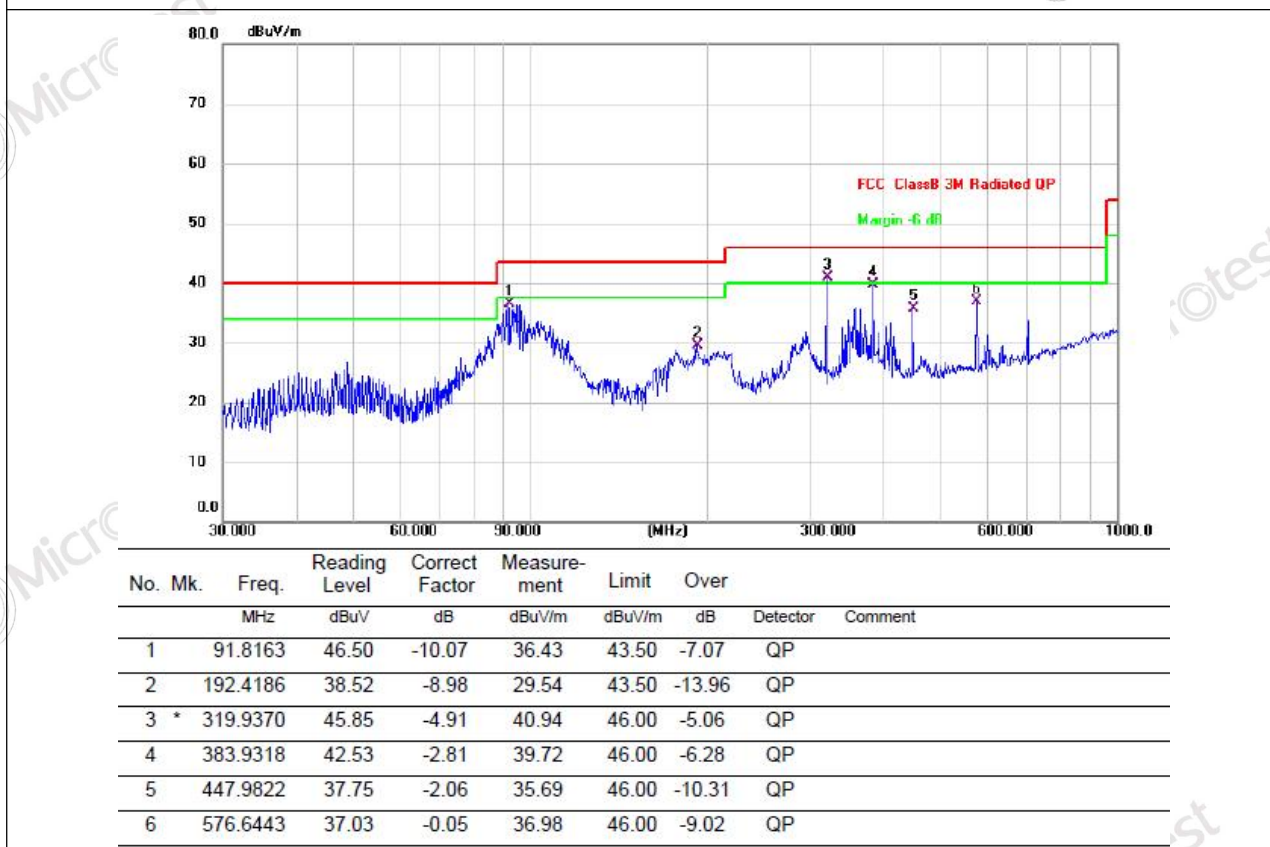

TEST REPORT

Report No.: MTi250717026-0106E1

Mode5 / Polarization: Vertical



No.	Mk.	Freq. MHz	Reading Level dBuV	Correct Factor dB	Measure- ment dBuV/m	Limit dBuV/m	Over dB	Detector	Comment
1	!	38.0783	44.30	-8.40	35.90	40.00	-4.10	QP	
2	*	51.1209	43.84	-7.38	36.46	40.00	-3.54	QP	
3		104.9033	43.51	-8.10	35.41	43.50	-8.09	QP	
4		208.5803	44.62	-8.42	36.20	43.50	-7.30	QP	
5	!	383.9318	44.24	-2.81	41.43	46.00	-4.57	QP	
6	!	576.6443	40.46	-0.05	40.41	46.00	-5.59	QP	

TEST REPORT

Report No.: MTi250717026-0106E1

Photographs of the test setup

Refer to Appendix - Test Setup Photos

TEST REPORT

Report No.: MTi250717026-0106E1

Photographs of the EUT

Refer to Appendix - EUT Photos

TEST REPORT

Report No.: MTi250717026-0106E1

Statement

1. This report is invalid without the seal and signature of the laboratory.
2. The test results of this report are only responsible for the samples submitted. Client shall be responsible for representativeness of the sample and authenticity of the material.
3. The report shall not be partially reproduced without the written consent of the Laboratory.
4. This report is invalid if transferred, altered or tampered with in any form without authorization.
5. The observations or tests with special mark fall outside the scope of accreditation, and are only used for purpose of commission, research, training, internal quality control etc.
6. Any objection to this report shall be submitted to the laboratory within 15 days from the date of receipt of the report.

***** END OF REPORT *****