





CZ-22(充电款) 说明书

成品尺寸: 65X90mmm 折叠方式: 关门折

材质及工艺: 105g 铜版纸

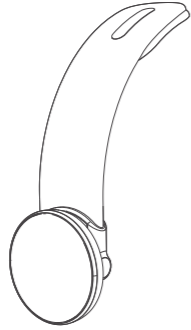
印刷颜色: 单色印刷 (白底黑字)

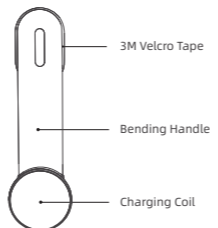
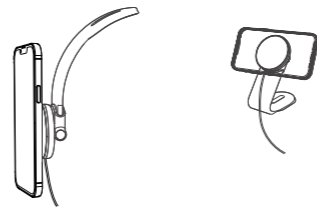
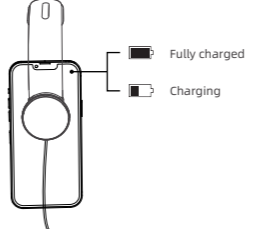
90mm
65mm

 <p>Car mounted magnetic suction wireless charging bracket Quick User Guide</p>	<p>Product Specification</p> <p>Product Name: Car mounted magnetic suction wireless charging bracket Product Model: CZ-22 Product Size: 214 x 60.5 x 20.9mm Product Material: Aluminum Alloy+TPU+Magnet Product Weight: 112g Input: 5V/3A; 9V/3A Output: 15W/10W/7.5W/5W Magnetic Pull: 15N (without protection case) / 18N (with metal ring plate) Compatible for dashboard, car monitor. Accessories: 1pc x extra 3M Velcro Tape, 1pc x Metal Ring, 1pc x Protective film, 1set x Wet and Dry-Cleaning Wipes, 1pc x Positioning Tool, 1pc x 1m USB-A to Type-C cable</p> <p>Package Content</p> <ul style="list-style-type: none"> <li style="width: 50%;">① Magnetic wireless car charger *1 <li style="width: 50%;">③ Charging Cable*1 <li style="width: 50%;">② Metal ring plate*1 <li style="width: 50%;">④ Positioning tool*1 <li style="width: 50%;">Wet Dry ⑤ Wet&dry-cleaning wipes*1 <li style="width: 50%;">⑥ Protective film*1 <li style="width: 50%;">⑦ Quick User Guide*1 <li style="width: 50%;">⑧ extra 3M Velcro Tape 	<p>How to Install</p> <ol style="list-style-type: none"> Please wipe the surface with the wet alcohol wipe and keep it dry before stick the 3M Velcro tape. Peel off the 3M tape and stick the Velcro tape to the center console/dashboard/behind of the car monitor, and wait for 24 hours. Bend the holder as you want, stick it on the 3M Velcro tape. 	<p>How to Use</p> <p>For iPhone 15/14/13/12 series with MagSafe</p> <ol style="list-style-type: none"> Connect the USB plug to car charger port and Type-C plug to your holder.  	<ol style="list-style-type: none"> Connect the mobile phone with the wireless charger to charge. Note that you can know the charging status by the battery display on the phone screen.  <p>Charging Status Display: P.S. Please kindly note the branding light is not indicator light.</p> 	<p>For Use With Non-MagSafe Phones:</p> <ol style="list-style-type: none"> Clean the back of your phone or case with the provided wet and dry wipes. Then determine the center with the positioning tool. NECESSARY: Stick the protective film on the center before installing the metal ring. Attach the metal ring to the center, on top of the protective film. <p>Attention:</p> <ol style="list-style-type: none"> Use with the phone case will affect the magnetic attraction, you can stick the metal ring plate to the phone cases. Make sure the surface is clean and dry before you stick the 3M Velcro tape on it. After you stick the 3M Velcro tape on your car, please wait for 24 hours. The handle part of holder can withstand 300 bends, please avoid bending too many times in a short period of time. Please avoid 180 degrees bending. <p>Made in China</p> 
--	--	---	---	--	---

FCC Requirement

Any changes or modifications not expressly approved by the party responsible for compliance could void the user's authority to operate the equipment.

This device complies with Part 15 of the FCC Rules. Operation is subject to the following two conditions:

- (1) this device may not cause harmful interference, and
- (2) this device must accept any interference received, including interference that may cause undesired operation.

Note: This equipment has been tested and found to comply with the limits for a Class B digital device, pursuant to Part 15 of the FCC Rules. These limits are designed to provide reasonable protection against harmful interference in a residential installation. This equipment generates, uses, and can radiate radio frequency energy, and if not installed and used in accordance with the instructions, may cause harmful interference to radio communications. However, there is no guarantee that interference will not occur in a particular installation. If this equipment does cause harmful interference to radio or television reception, which can be determined by turning the equipment off and on, the user is encouraged to try to correct the interference by one or more of the following measures:

- Reorient or relocate the receiving antenna.
- Increase the separation between the equipment and receiver.
- Connect the equipment into an outlet on a circuit different from that to which the receiver is connected.
- Consult the dealer or an experienced radio/TV technician for help.