

## Appendix A

### RF Test Data for BT V5.0 (BDR/EDR) (Conducted Measurement)

Product Name: DEMERBOX

Trade Mark: DEMERBOX

Test Model: DB1

#### Environmental Conditions

Temperature:	23.1 °C
Relative Humidity:	53.4%
ATM Pressure:	100.0 kPa
Test Engineer:	Kay Hu
Supervised by:	Tom.Liu

#### A.1 Maximum Conducted Peak Output Power

Mode	Channel.	Maximum Peak Output Power [dBm]	Limit [dBm]	Verdict
GFSK	LCH	3.661	21	PASS
	MCH	3.988	21	PASS
	HCH	3.483	21	PASS
$\pi/4$ DQPSK	LCH	-0.131	21	PASS
	MCH	0.519	21	PASS
	HCH	-0.336	21	PASS
8DPSK	LCH	0.704	21	PASS
	MCH	1.327	21	PASS
	HCH	0.591	21	PASS

Test Graphs

GFSK/LCH

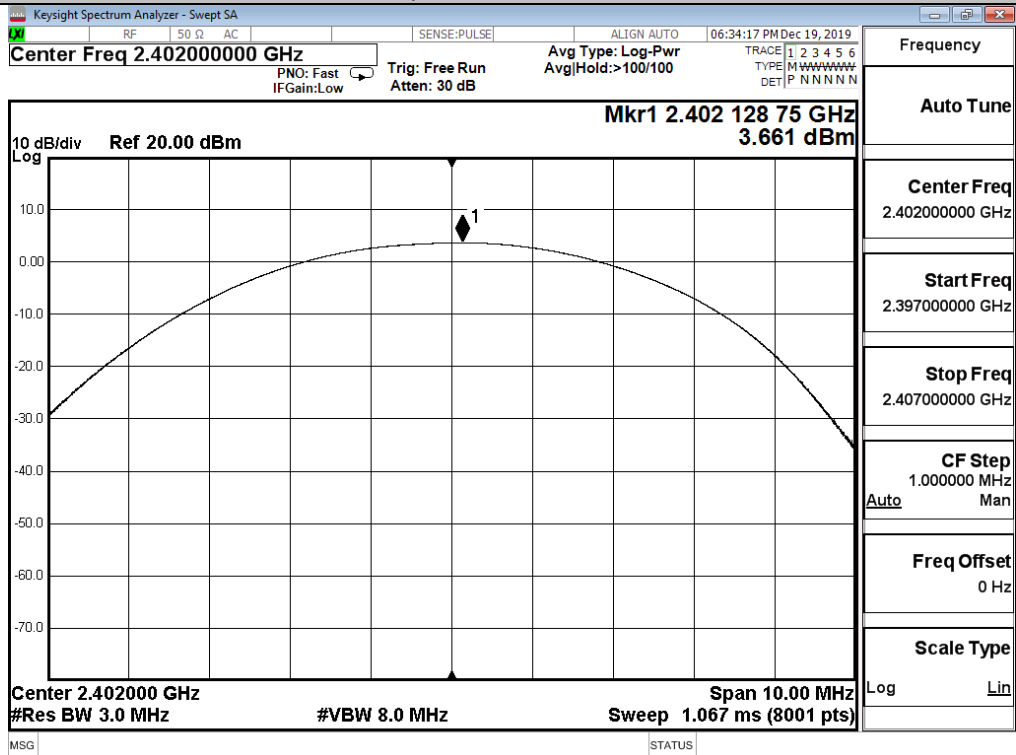

GFSK/MCH

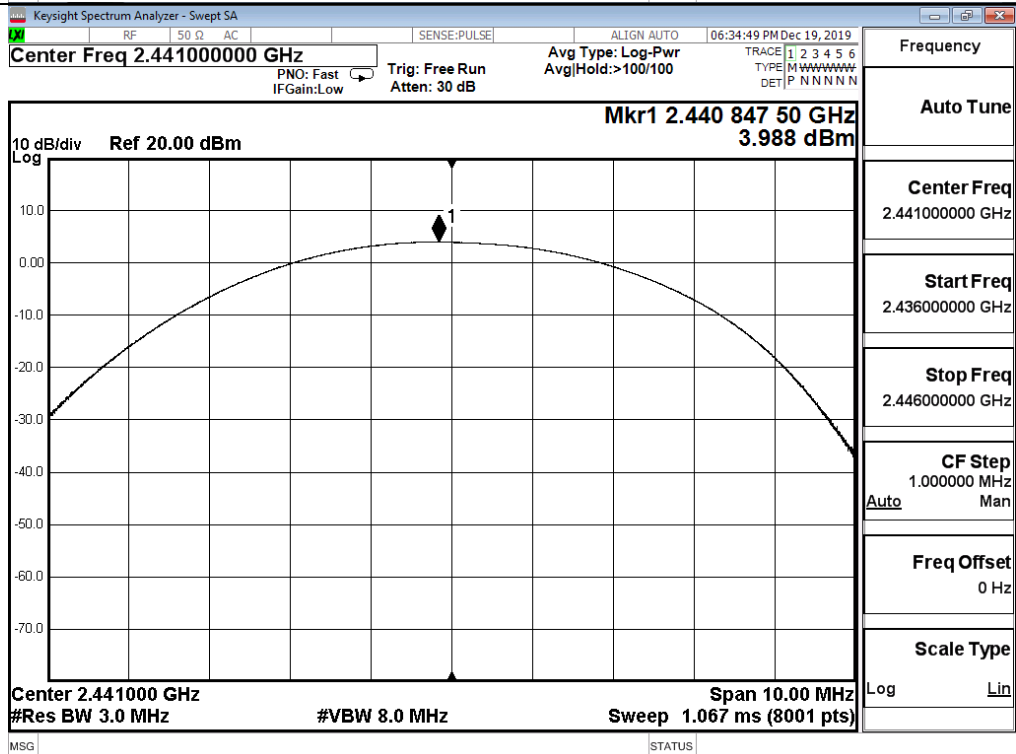

GFSK/HCH

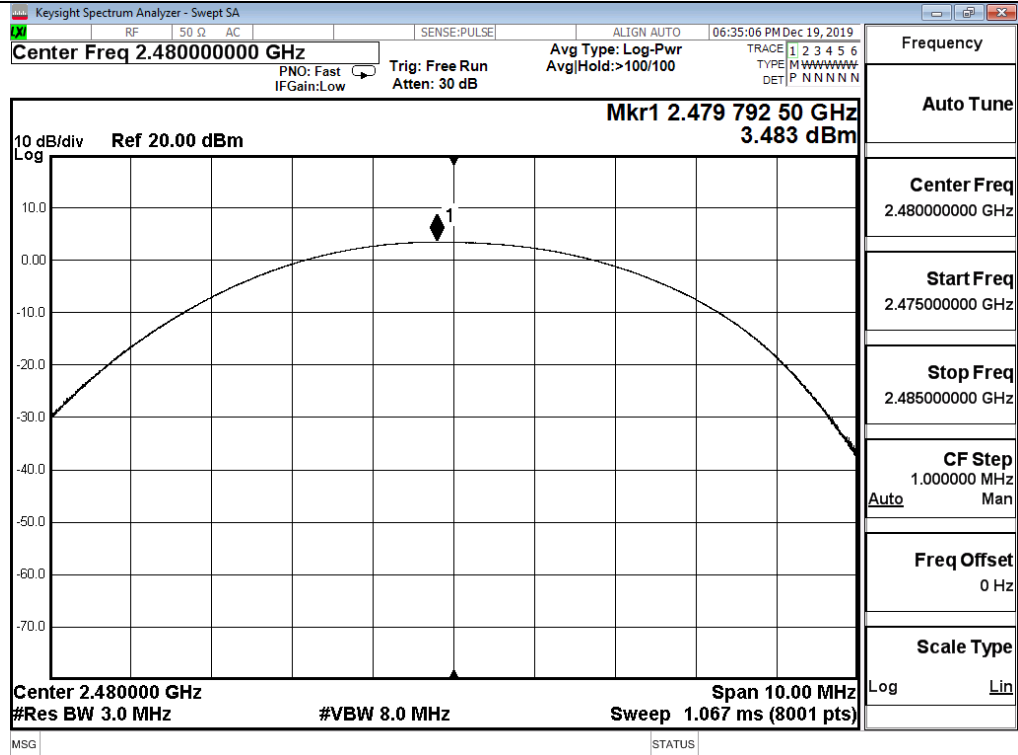

$\pi$ /4DQPSK/LCH

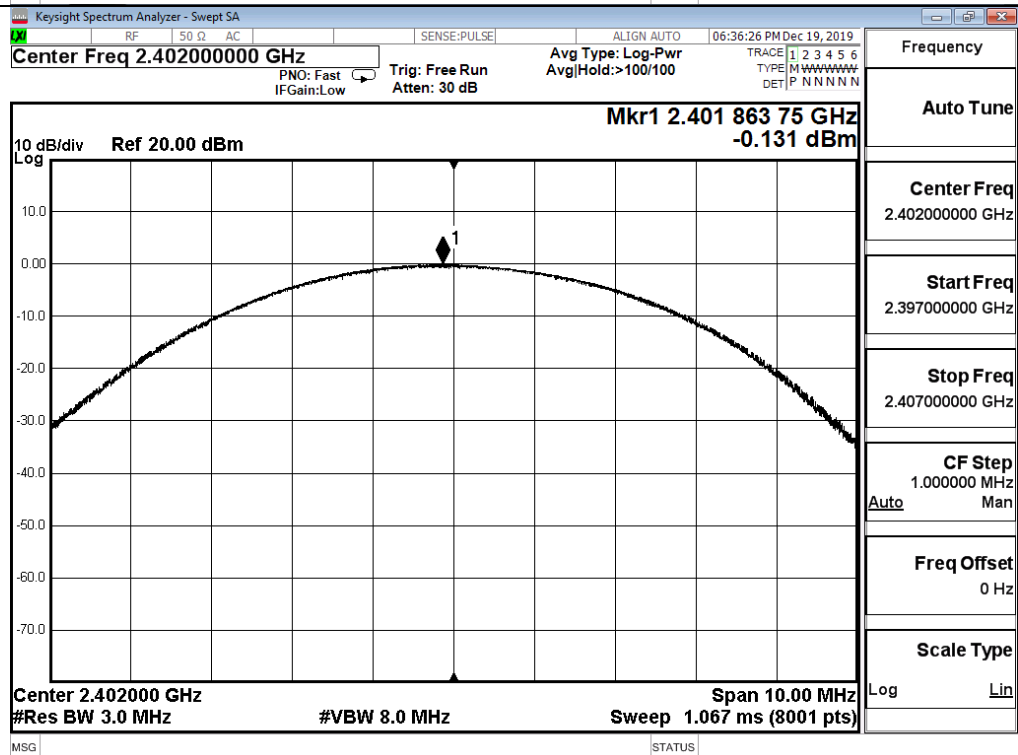

$\pi/4$ DQPSK/MCH

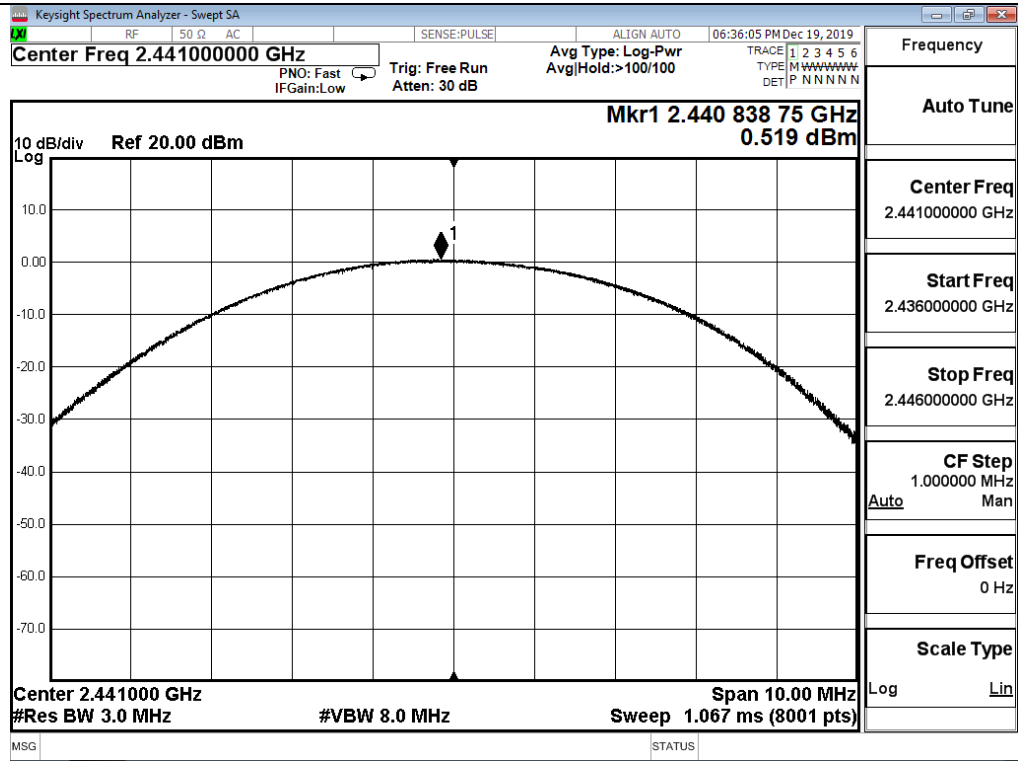

$\pi/4$ DQPSK/HCH

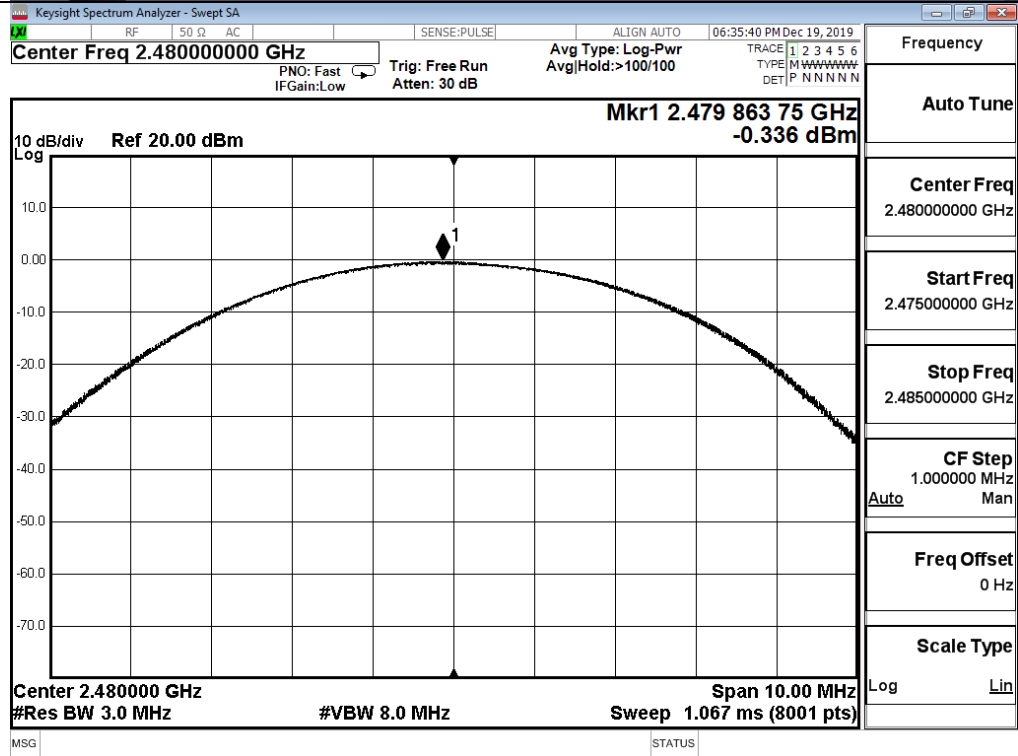

8DPSK/LCH

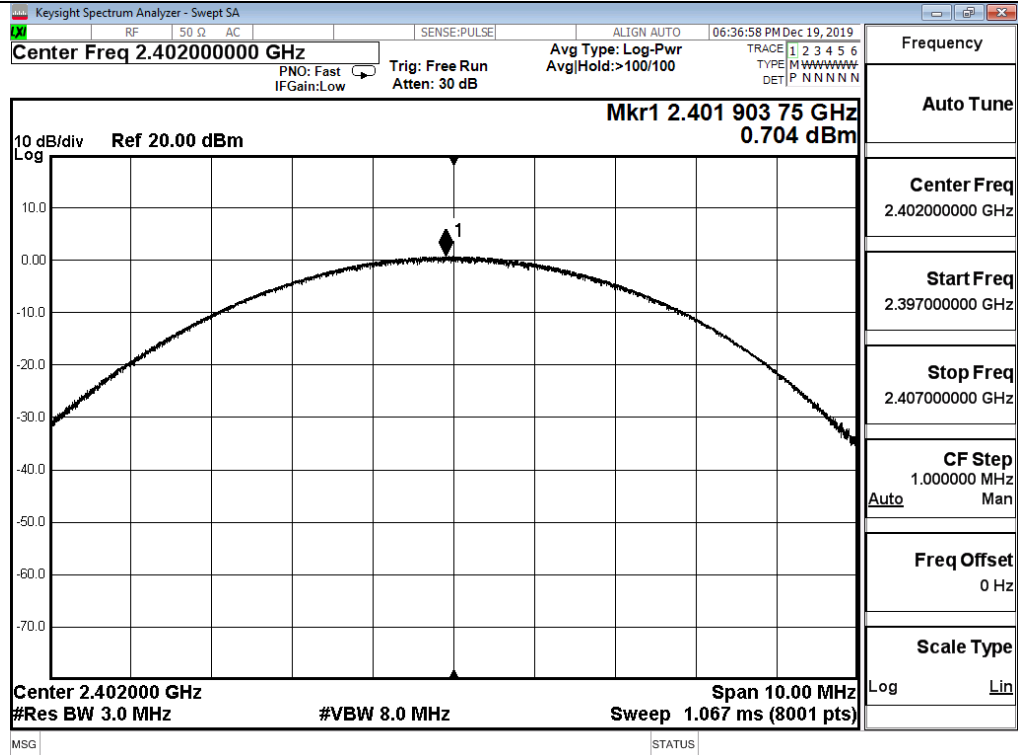

8DPSK/MCH

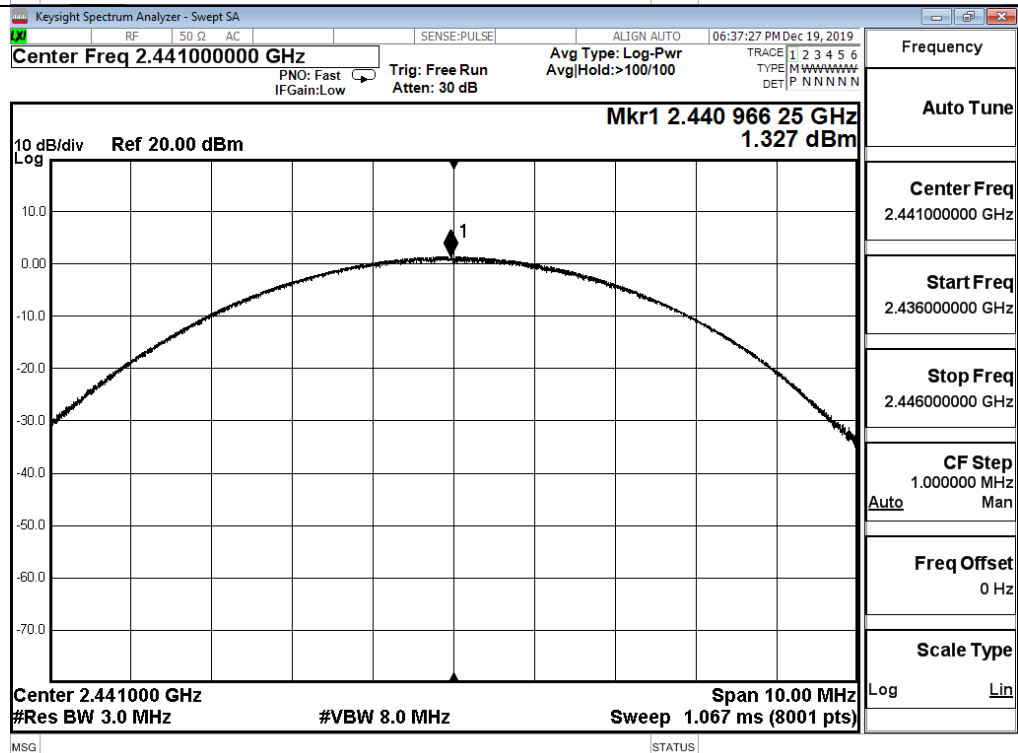

8DPSK/HCH

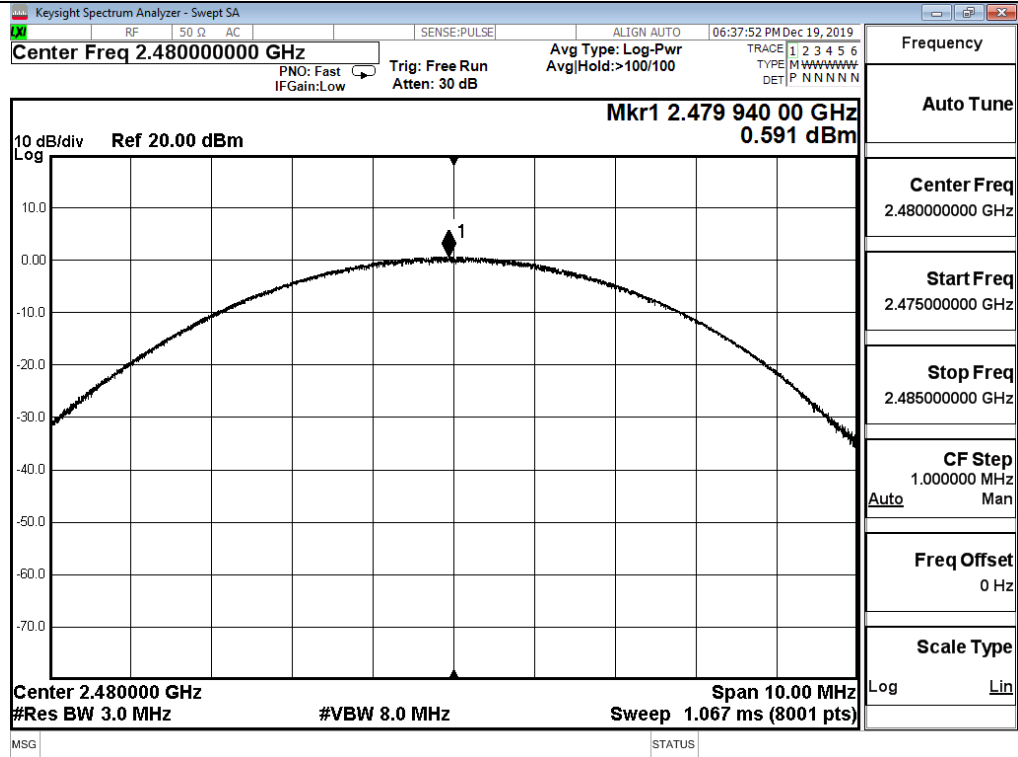

**A.2 99% and 20dB Bandwidth**

Mode	Channel.	99% Bandwidth [MHz]	20dB Bandwidth [MHz]	Limit [MHz]	Verdict
GFSK	LCH	0.83756	0.8672	Not Specified	PASS
	MCH	0.83804	0.8705	Not Specified	PASS
	HCH	0.83319	0.8683	Not Specified	PASS
π/4DQPSK	LCH	1.2027	1.209	Not Specified	PASS
	MCH	1.1959	1.208	Not Specified	PASS
	HCH	1.1990	1.209	Not Specified	PASS
8DPSK	LCH	1.1726	1.204	Not Specified	PASS
	MCH	1.1690	1.222	Not Specified	PASS
	HCH	1.1700	1.203	Not Specified	PASS

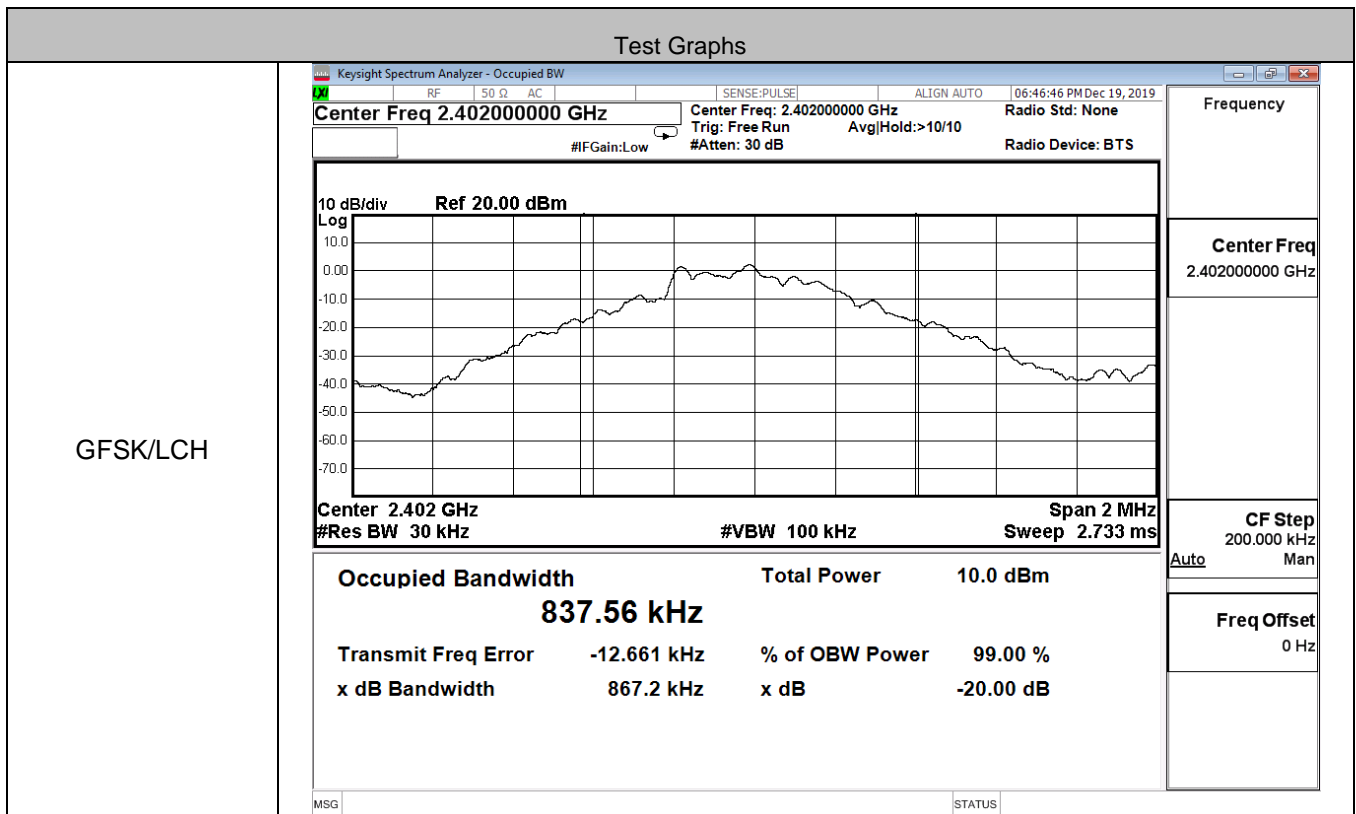

GFSK/MCH

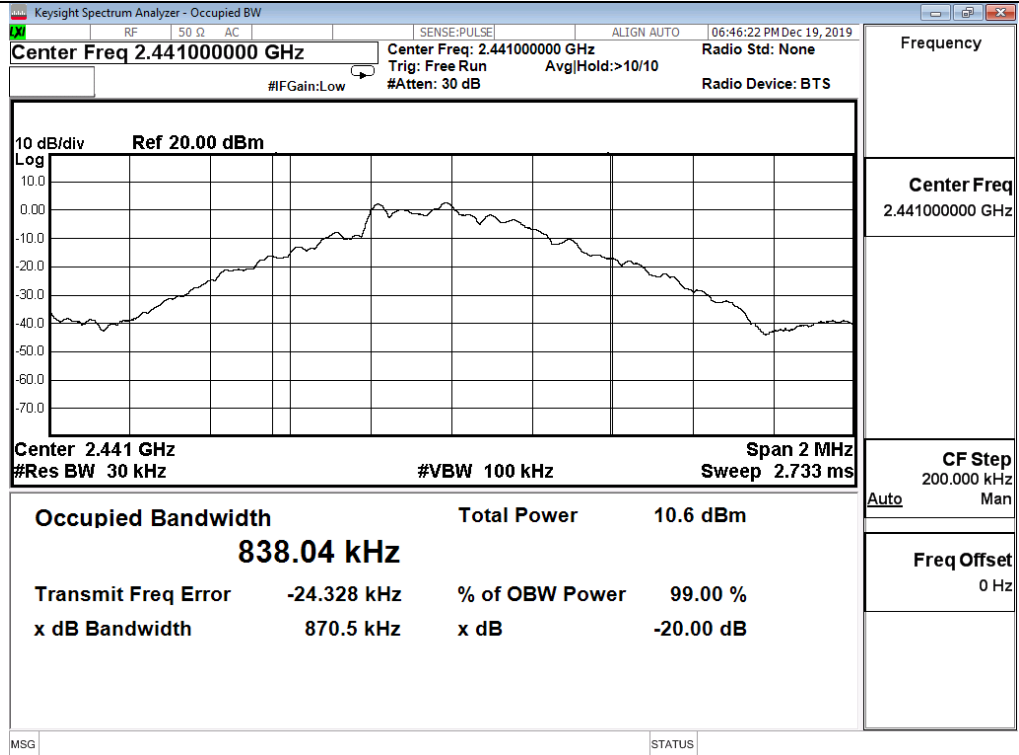

GFSK/HCH

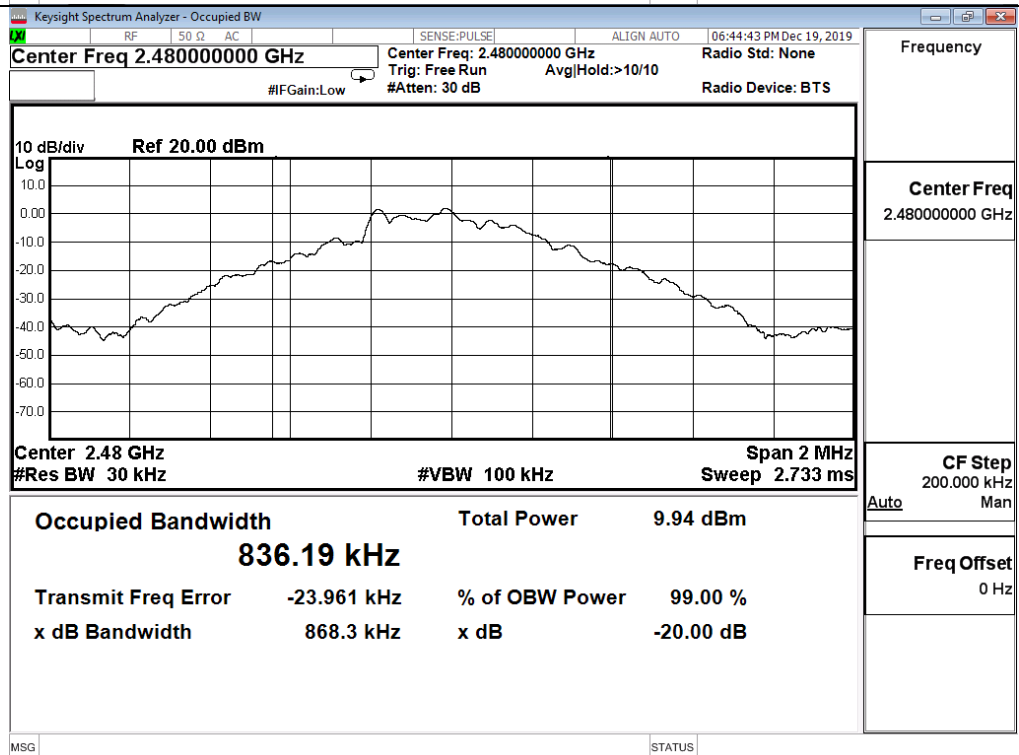



$\pi/4$ DQPSK/LCH

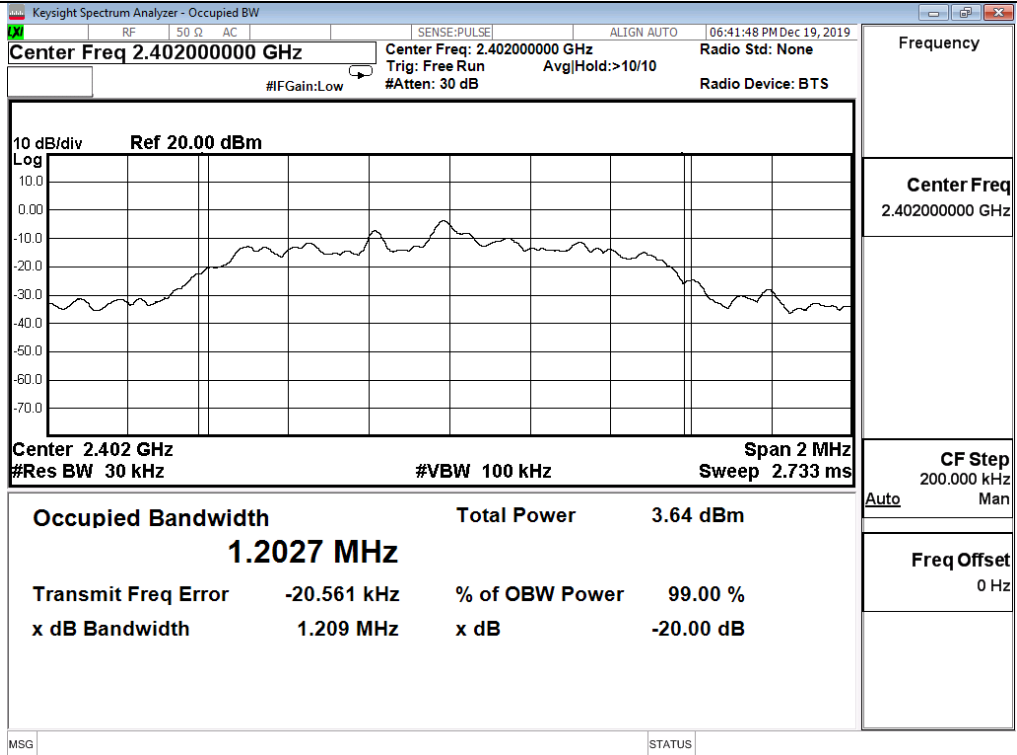

$\pi/4$ DQPSK/MCH

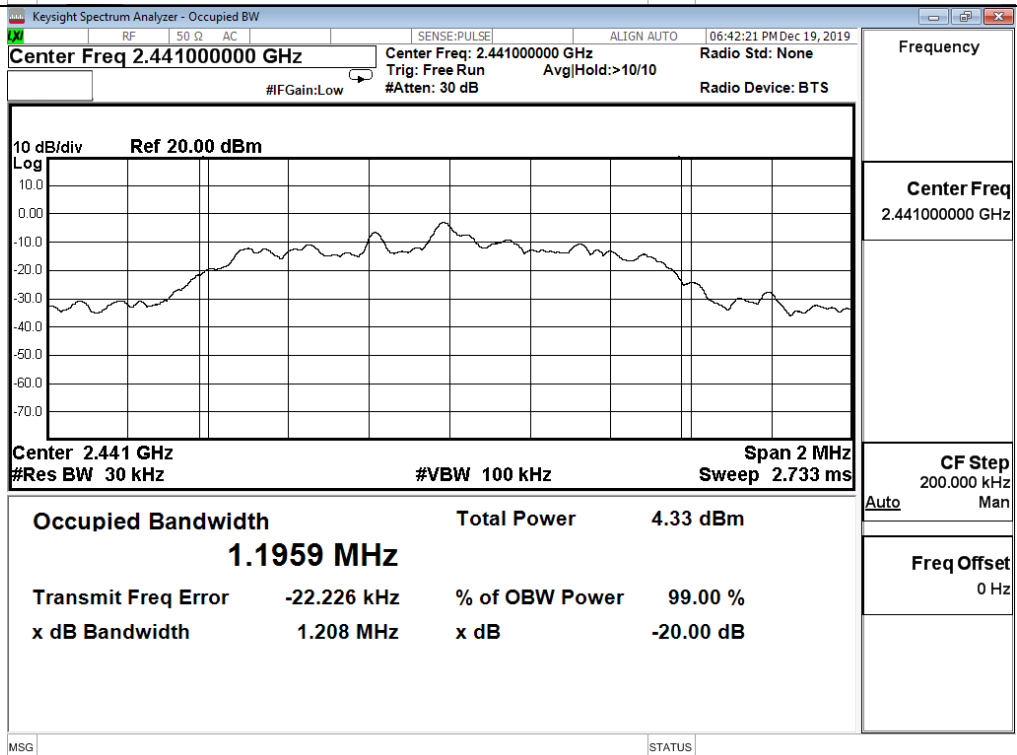

$\pi/4$ DQPSK/HCH

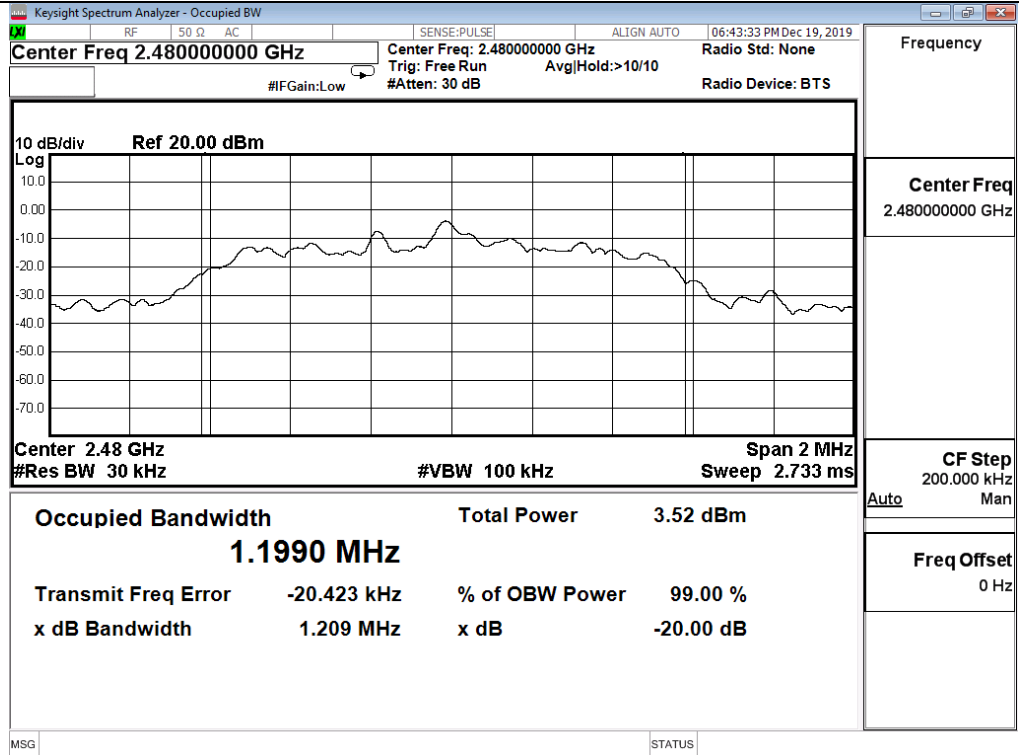

8DPSK/LCH

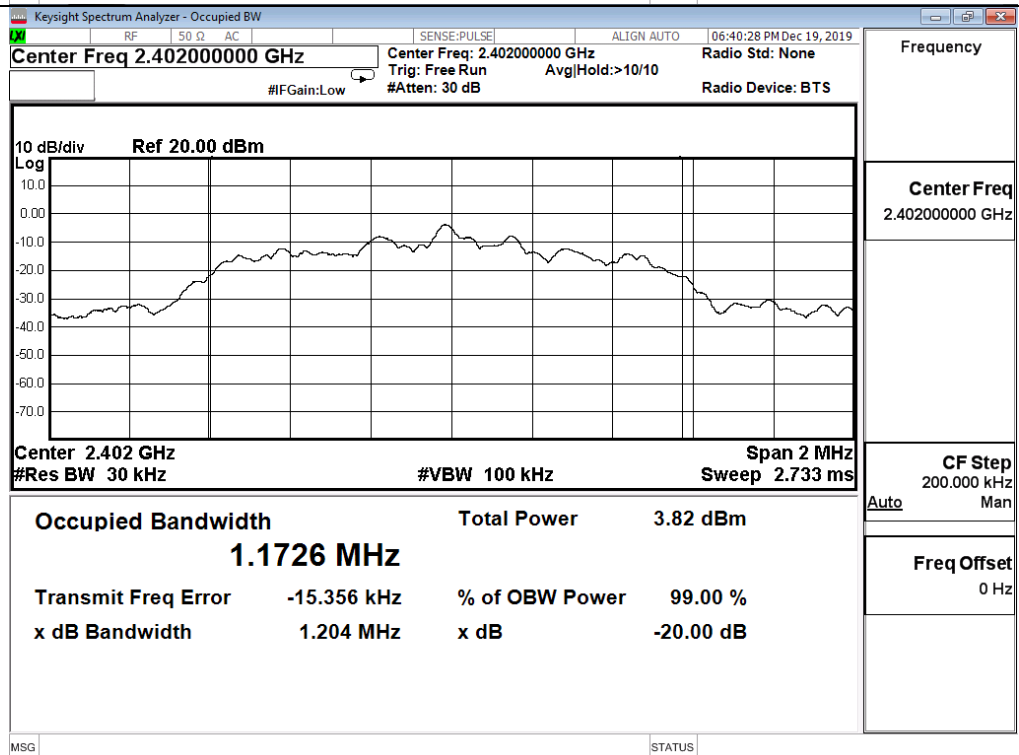

8DPSK/MCH

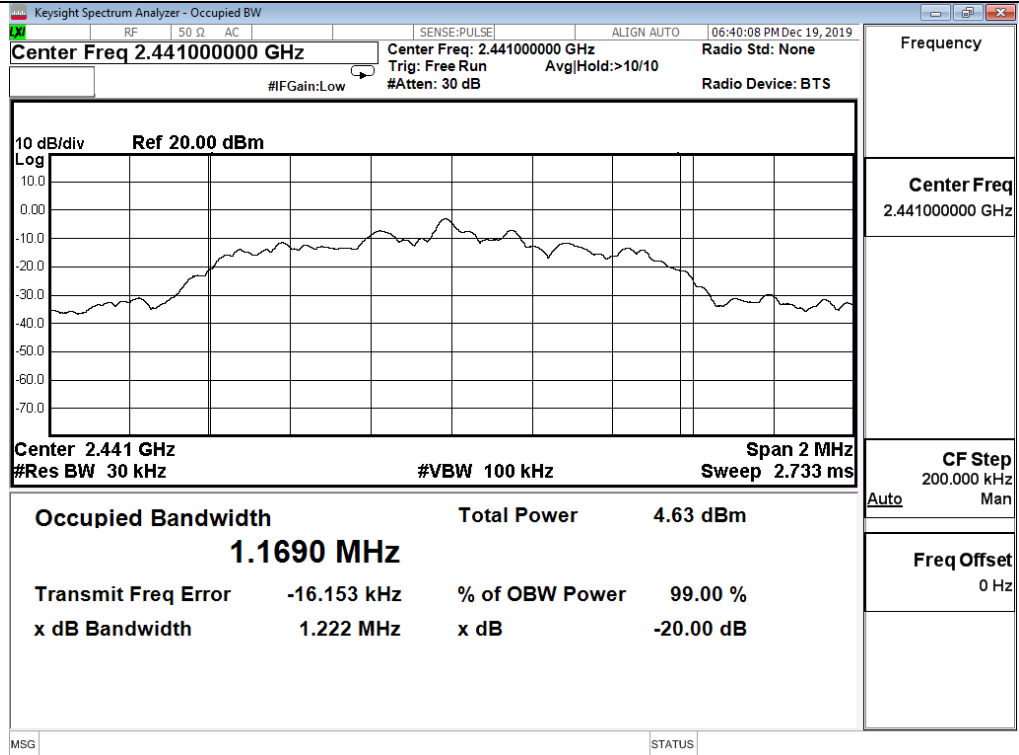

8DPSK/HCH

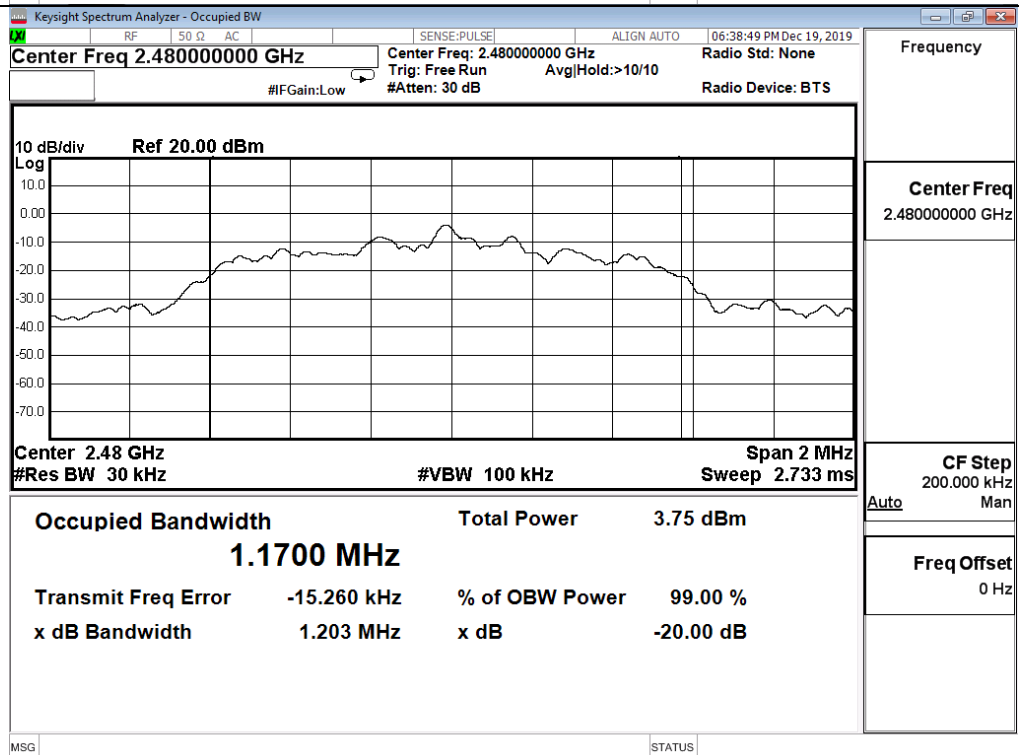

### A.3 Carrier Frequency Separation

Mode	Channel.	Carrier Frequency Separation [MHz]	Limit [MHz]	Verdict
GFSK	LCH	1.00150	0.58	PASS
	MCH	1.00050	0.58	PASS
	HCH	1.00075	0.58	PASS
π/4DQPSK	LCH	1.00425	0.81	PASS
	MCH	1.00000	0.81	PASS
	HCH	1.00225	0.81	PASS
8DPSK	LCH	0.99950	0.80	PASS
	MCH	1.00650	0.81	PASS
	HCH	1.00000	0.80	PASS

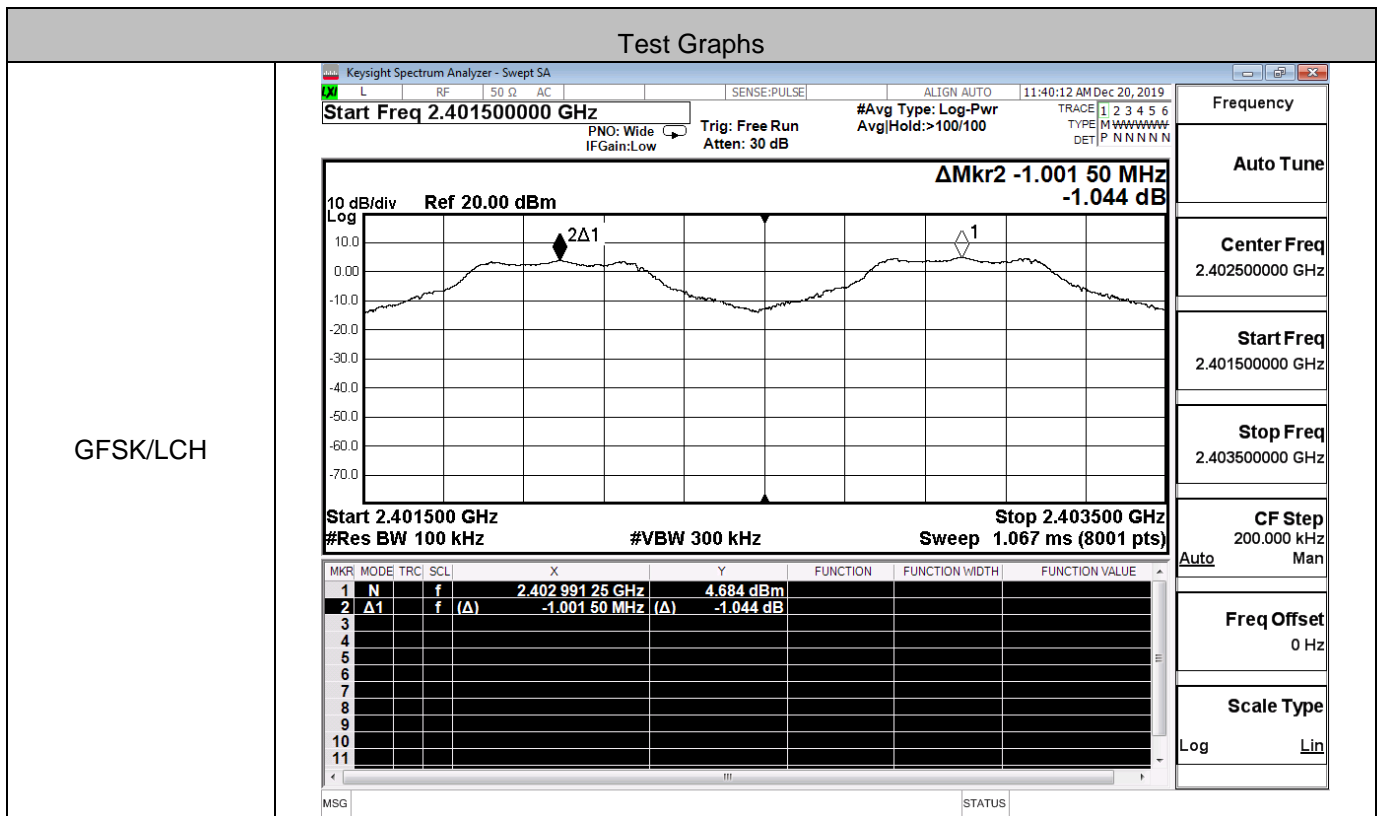

GFSK/MCH

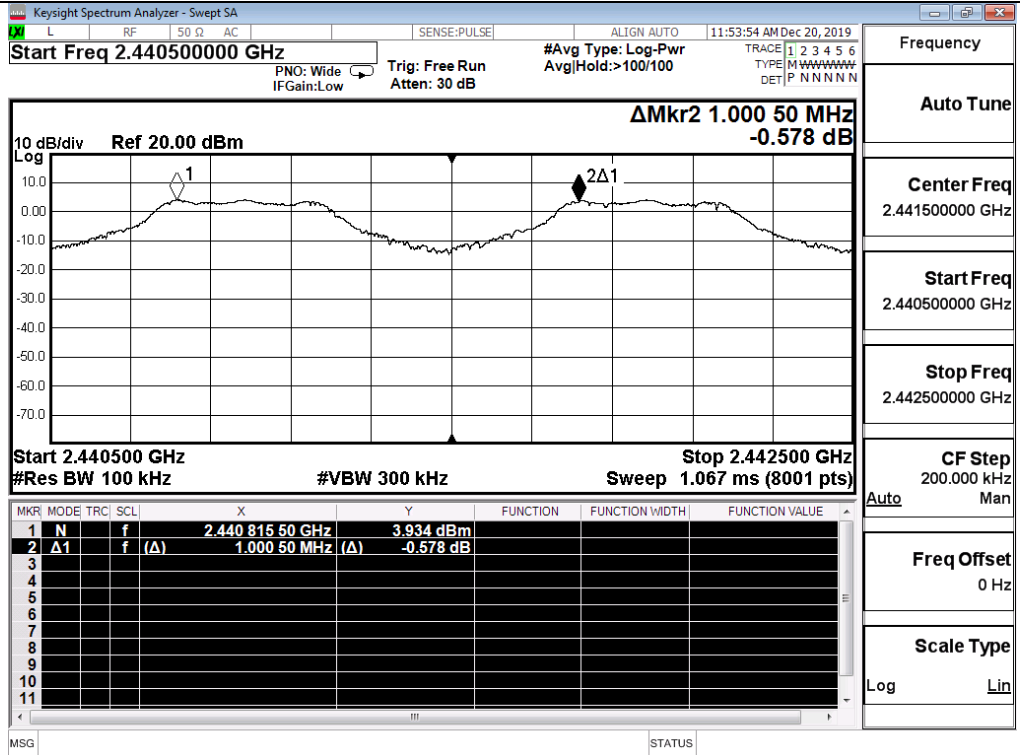

GFSK/HCH

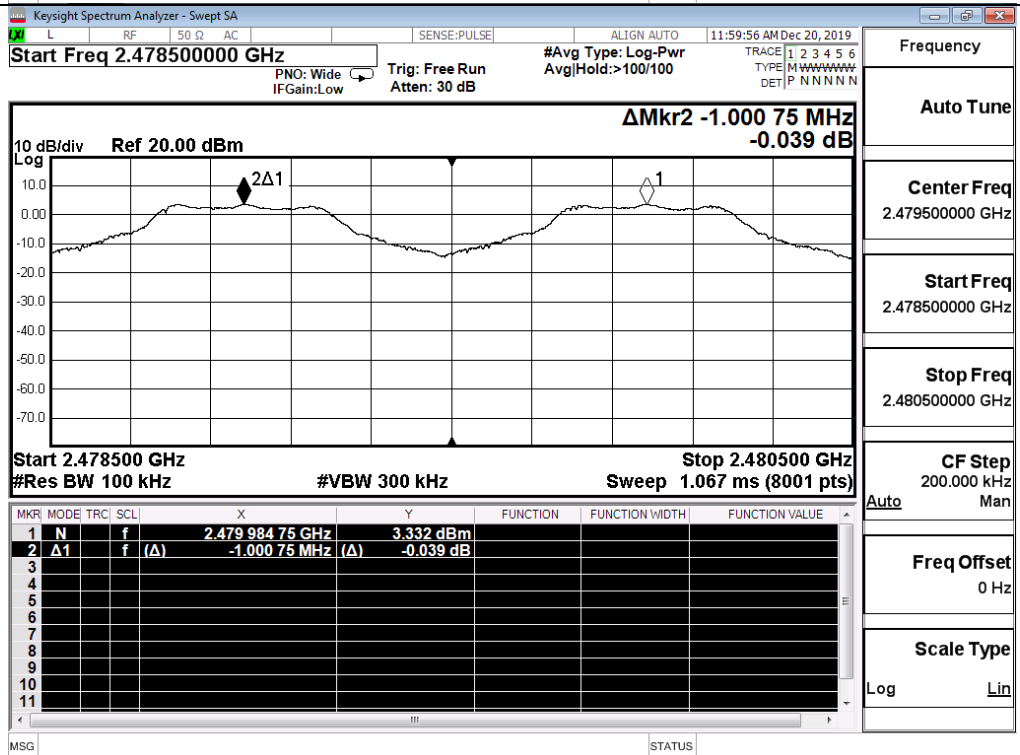

$\pi$ /4DQPSK/LCH

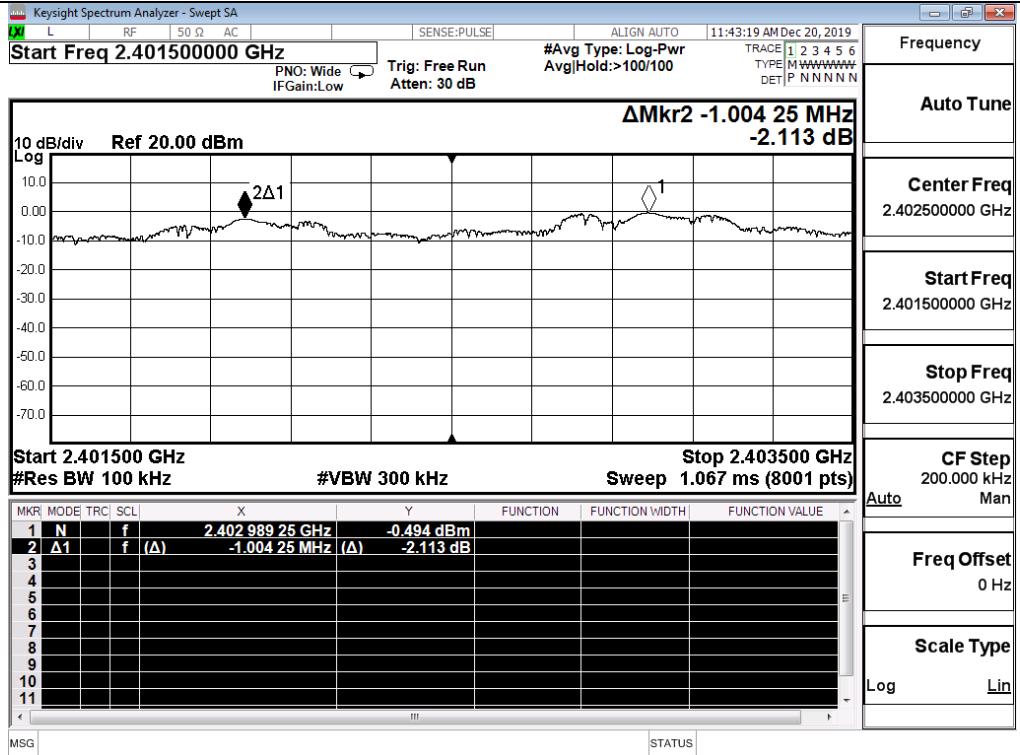

$\pi$ /4DQPSK/MCH

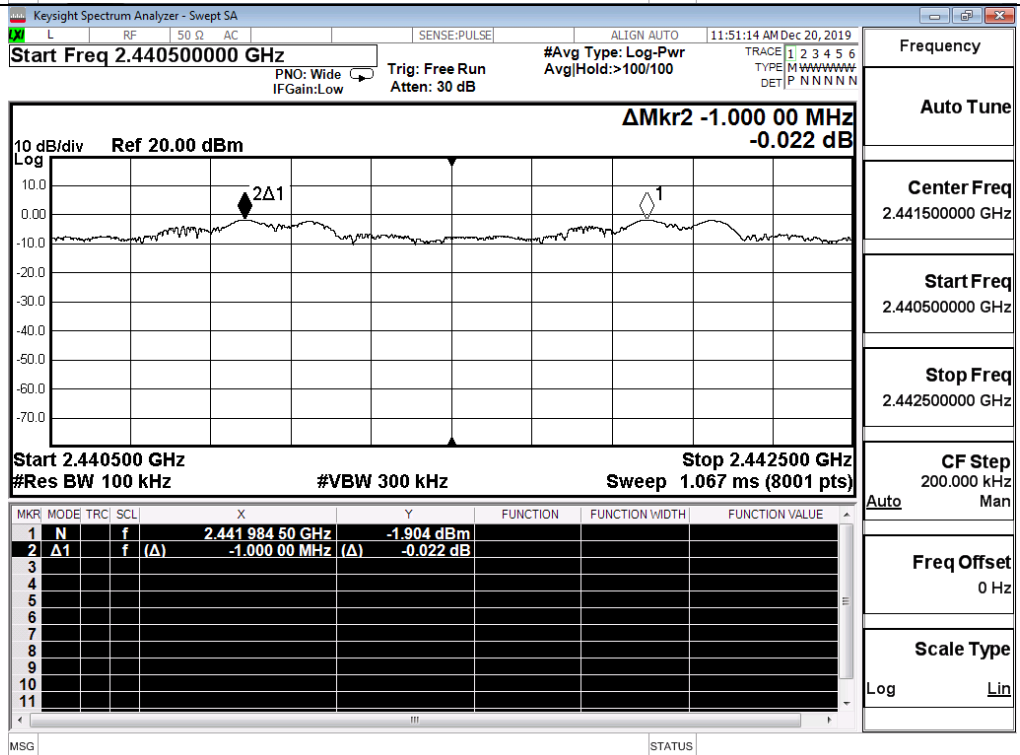

π/4DQPSK/HCH

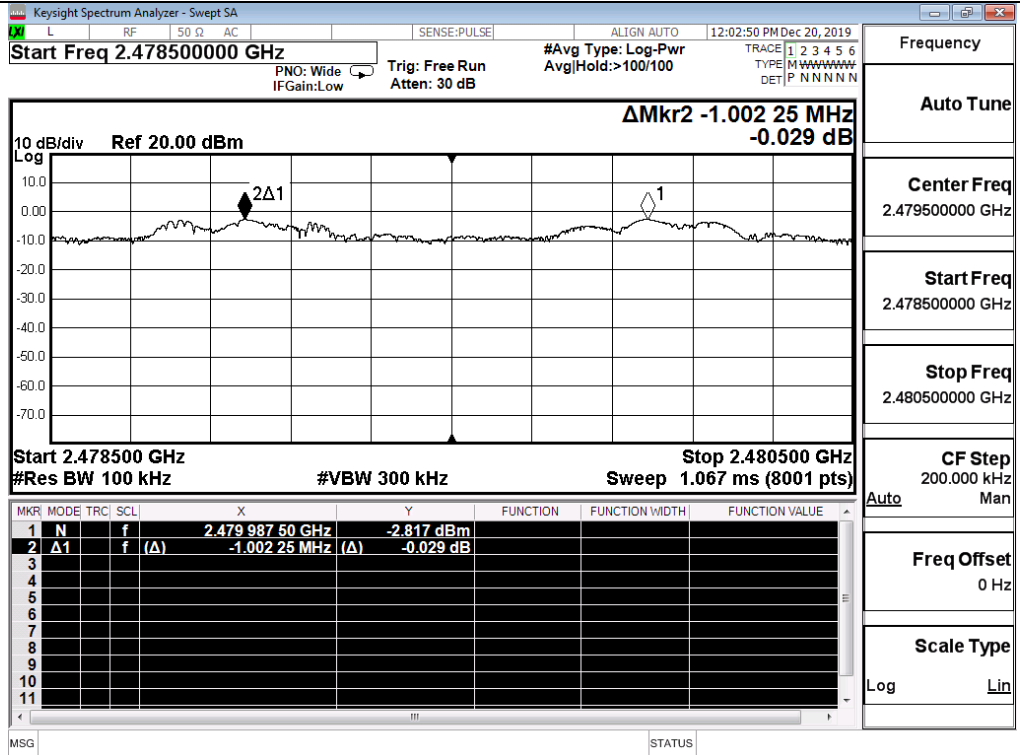

8DPSK/LCH

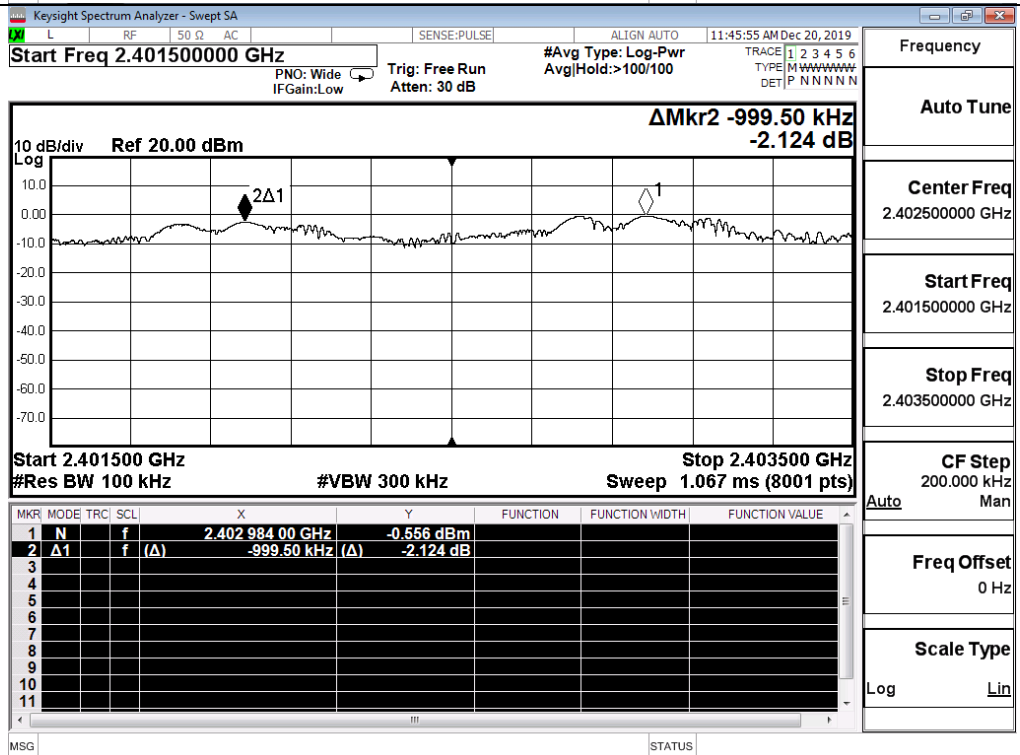

8DPSK/MCH

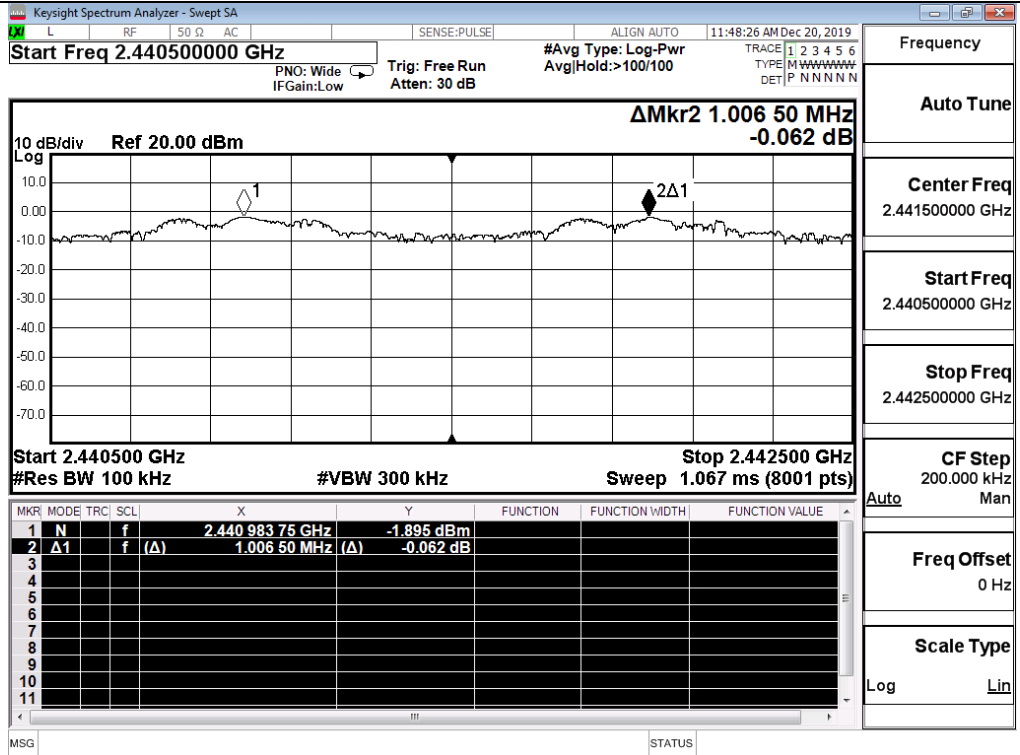

8DPSK/HCH

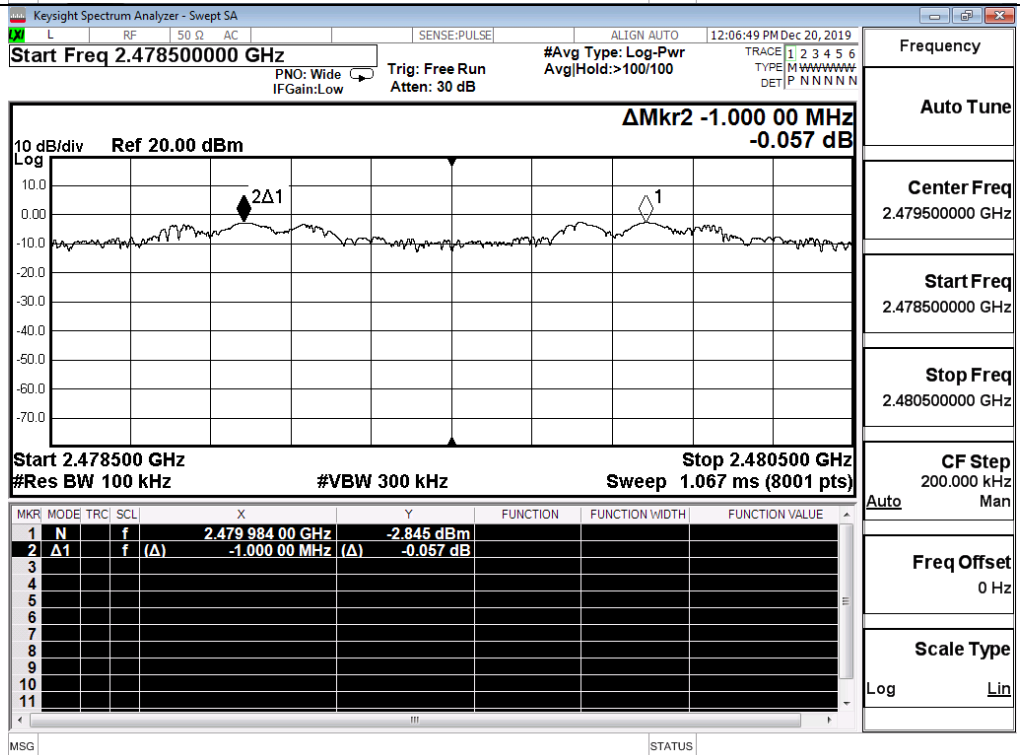



### A.4 Hopping Channel Number

Mode	Channel.	Number of Hopping Channel [N]	Limit [N]	Verdict
GFSK	Hop	79	>=15	PASS
$\pi/4$ DQPSK	Hop	79	>=15	PASS
8DPSK	Hop	79	>=15	PASS

Test Graphs

GFSK/Hop

MKR	MODE	TRC	SCL	X	Y	FUNCTION	FUNCTION WIDTH	FUNCTION VALUE
1	N	f		2.402 004 GHz	2.960 dBm			
2	$\Delta$ 1	f ( $\Delta$ )		78.003 MHz ( $\Delta$ )	-0.316 dB			

---

$\pi/4$ DQPSK/Hop

MKR	MODE	TRC	SCL	X	Y	FUNCTION	FUNCTION WIDTH	FUNCTION VALUE
1	N	f		2.401 983 GHz	-2.980 dBm			
2	$\Delta$ 1	f ( $\Delta$ )		78.013 MHz ( $\Delta$ )	-0.094 dB			

8DPSK/Hop

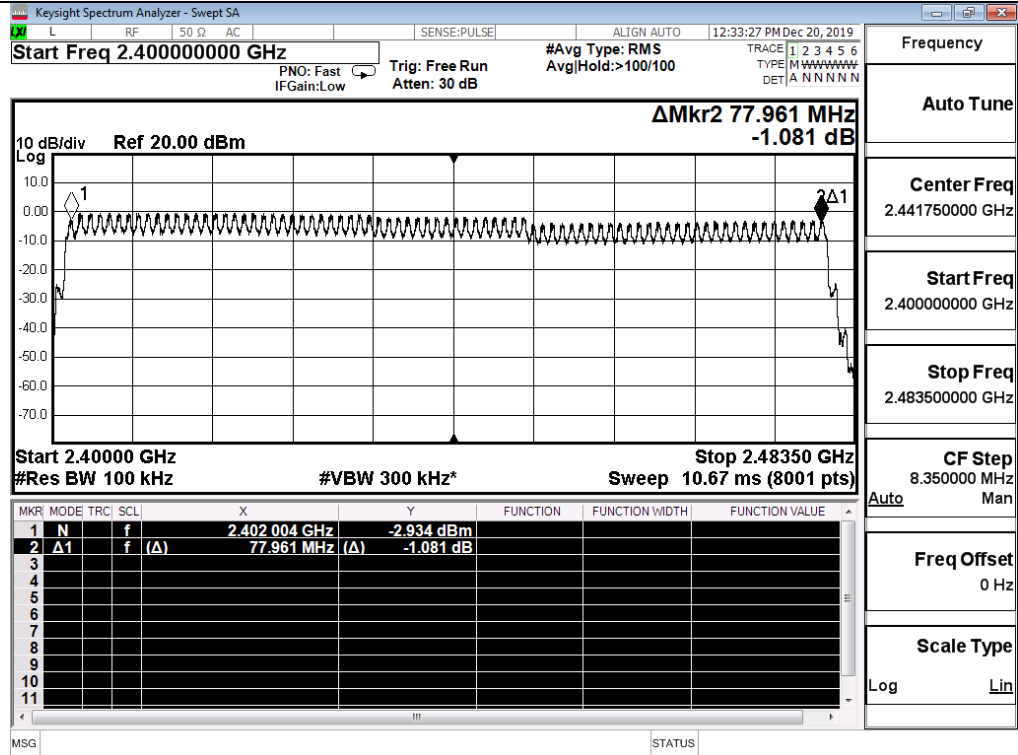

A.5 Dwell Time

Mode	Packet	Channel	Burst Width [ms/hop/ch]	Total Hops[hop*ch]	Dwell Time[s]	Limit [s]	Verdict
GFSK	DH5	LCH	2.889	106.7	0.31	0.4	PASS
	DH5	MCH	2.887	106.7	0.31	0.4	PASS
	DH5	HCH	2.893	106.7	0.31	0.4	PASS
π/4DQPSK	2DH5	LCH	2.892	106.7	0.31	0.4	PASS
	2DH5	MCH	2.894	106.7	0.31	0.4	PASS
	2DH5	HCH	2.899	106.7	0.31	0.4	PASS
8DPSK	3DH5	LCH	2.867	106.7	0.31	0.4	PASS
	3DH5	MCH	2.892	106.7	0.31	0.4	PASS
	3DH5	HCH	2.895	106.7	0.31	0.4	PASS

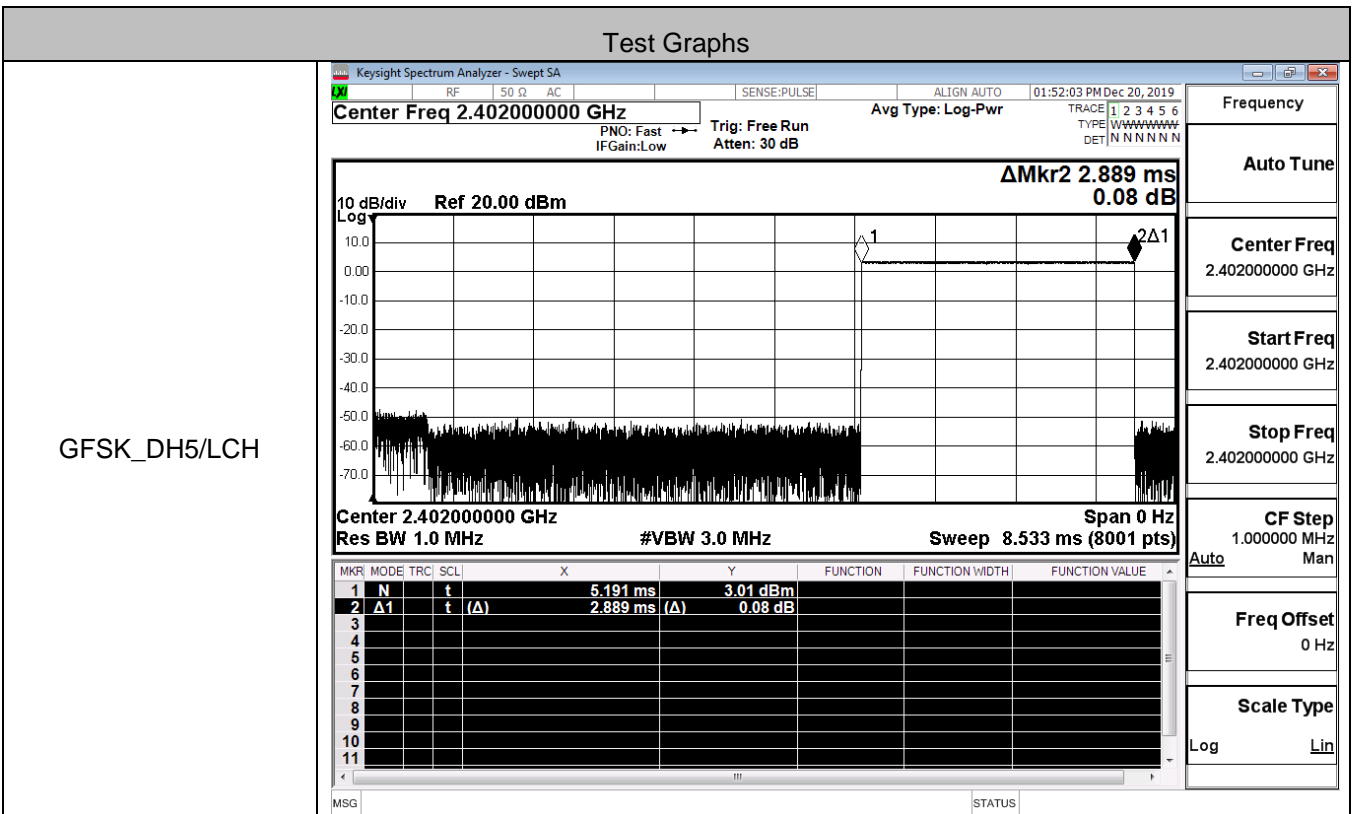

GFSK\_DH5/MCH

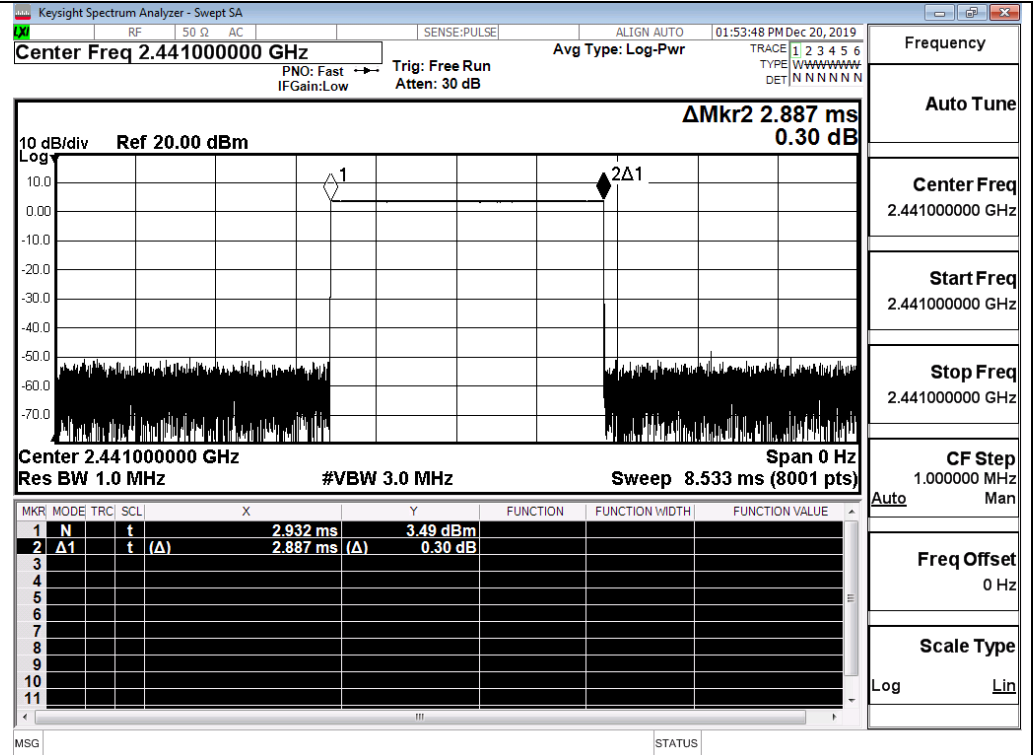

GFSK\_DH5/HCH

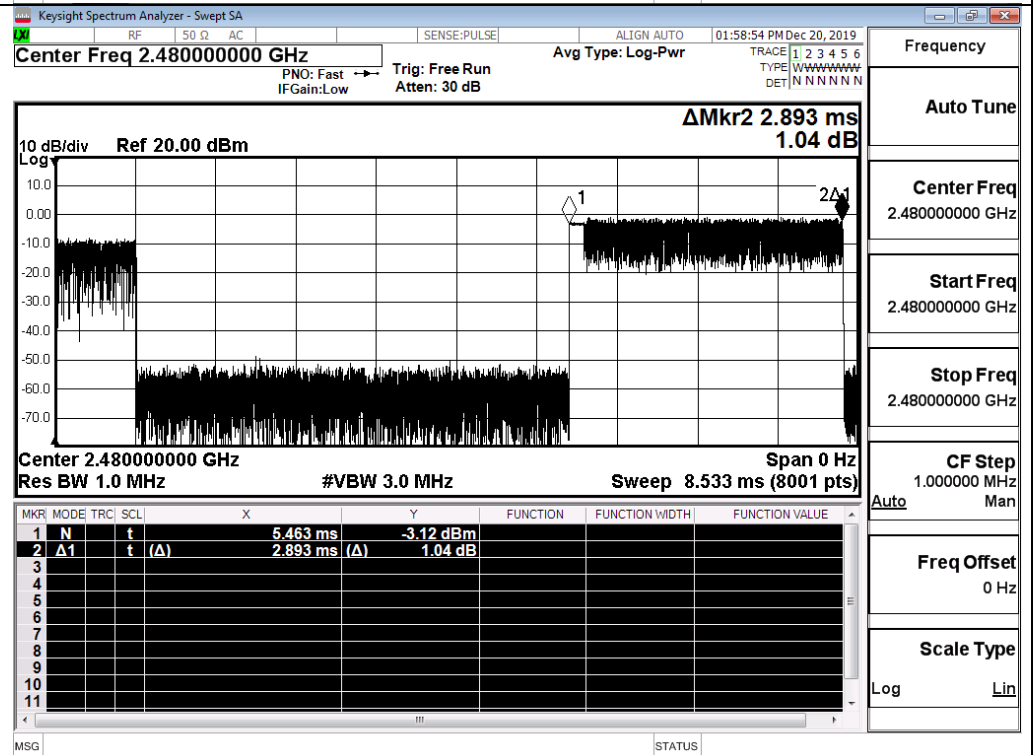

$\pi/4$ DQPSK  
\_2DH5/LCH

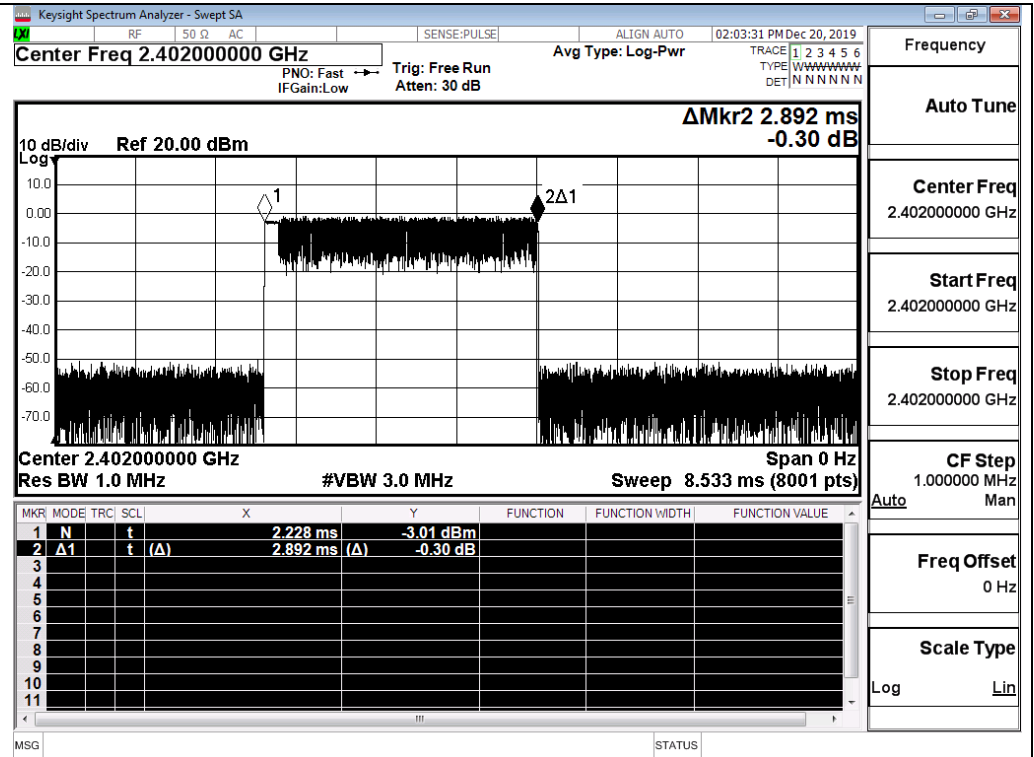

$\pi/4$ DQPSK  
\_2DH5/MCH

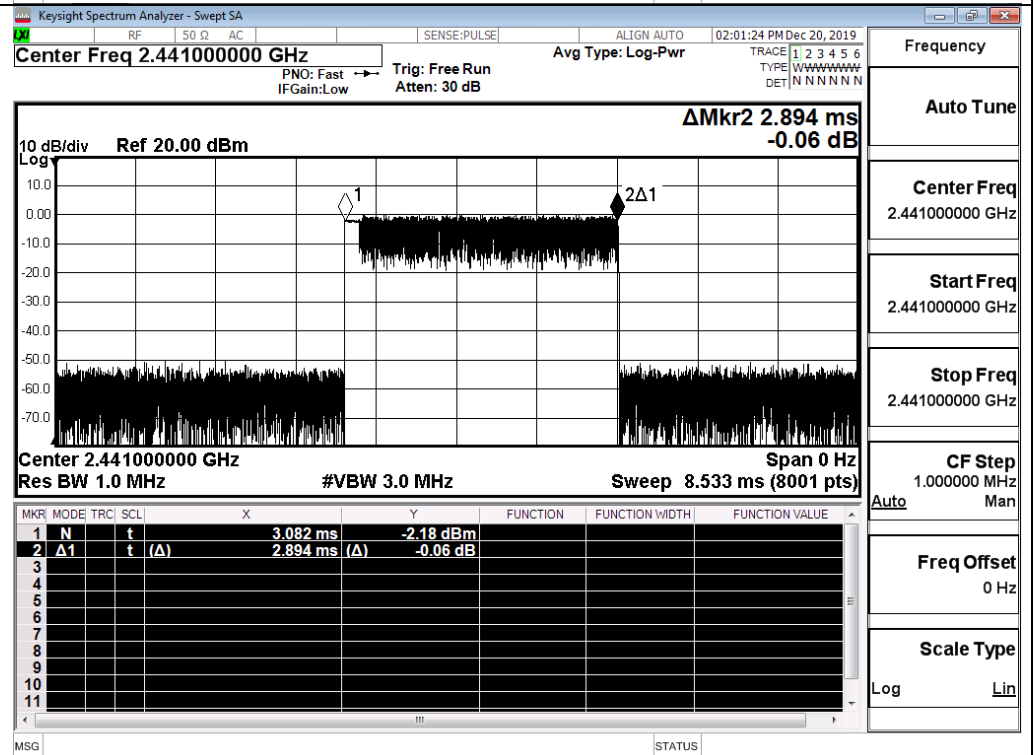

$\pi/4$ DQPSK  
\_2DH5/HCH

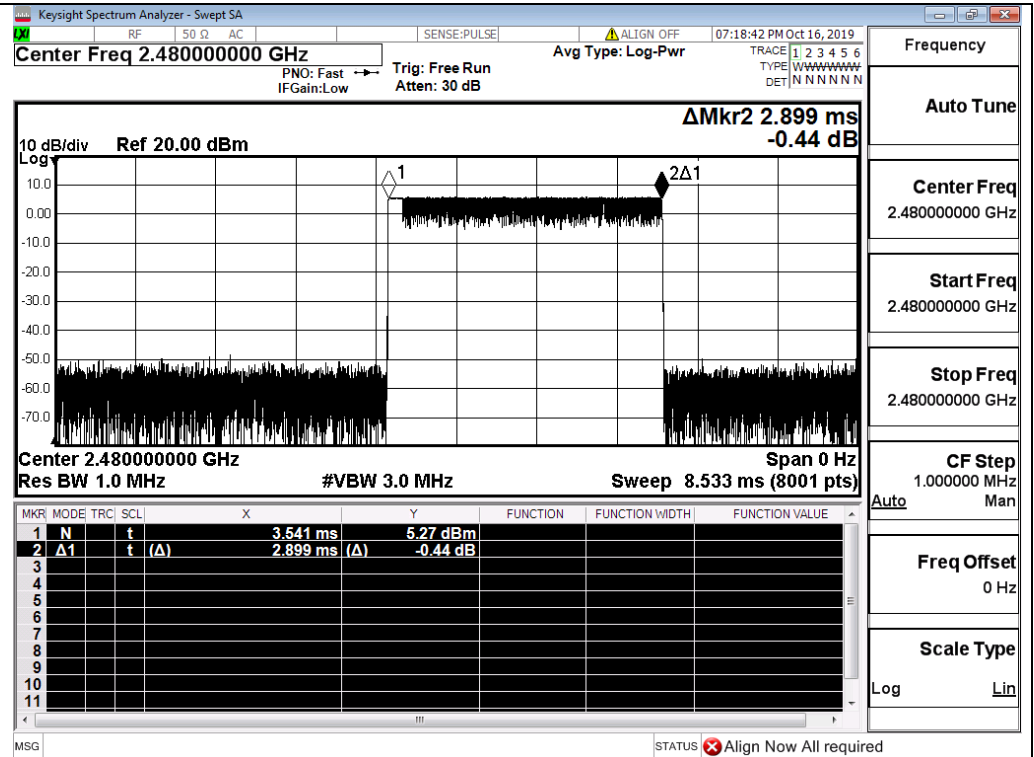

8DPSK\_3DH5/LCH

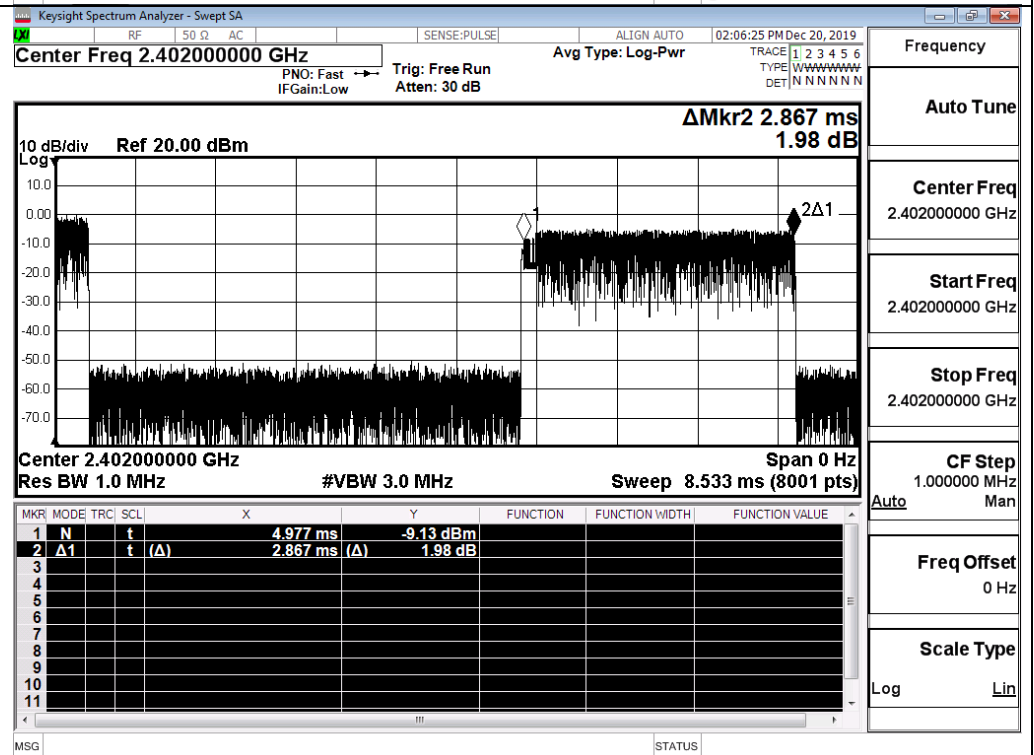

8DPSK\_3DH5/MCH

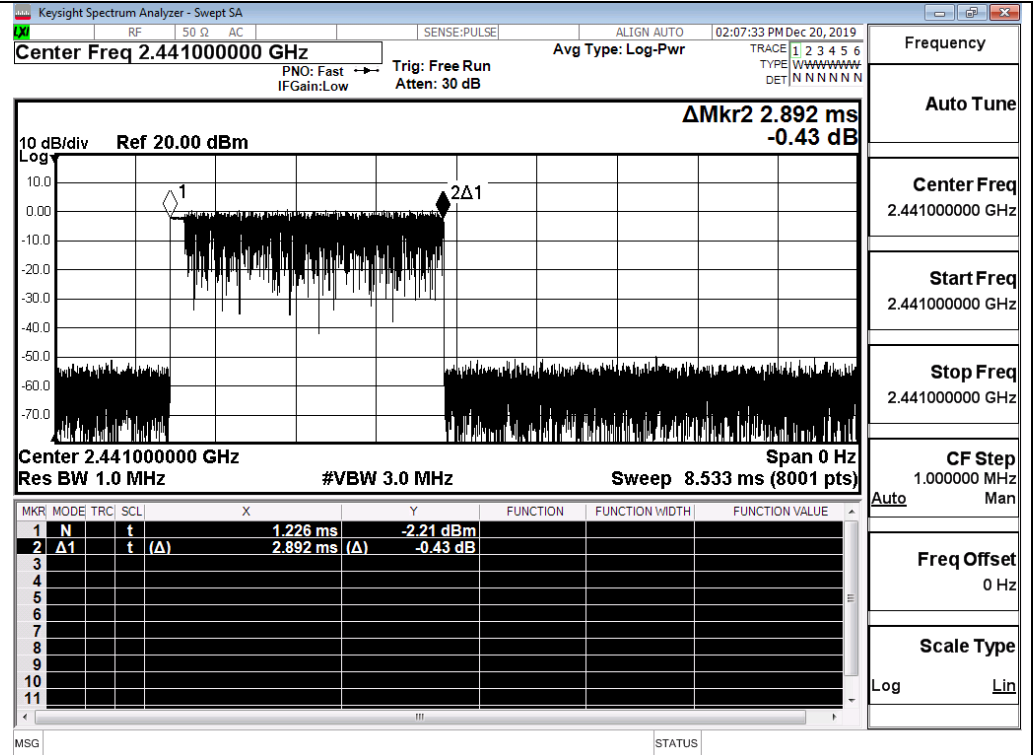

8DPSK\_3DH5/HCH

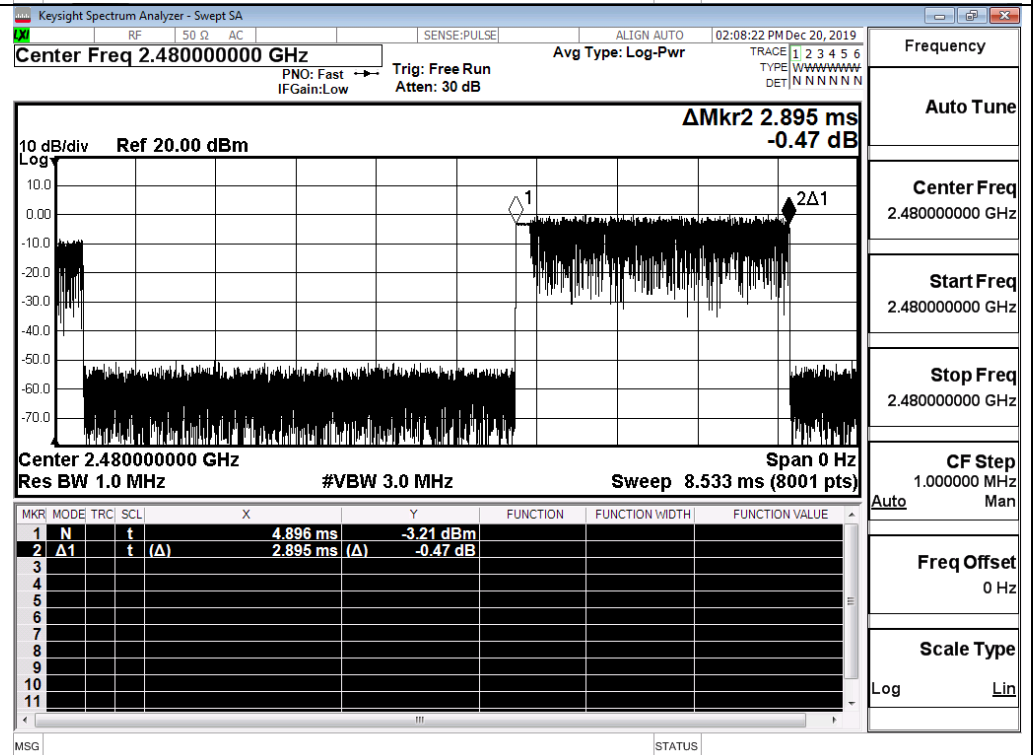

**A.6 RF Conducted Spurious Emissions**

Mode	Channel	Pref [dBm]	Max. Level [dBm]	Limit [dBm]	Verdict
GFSK	LCH	3.583	-48.674	-16.42	PASS
	MCH	-15.86	-48.559	-15.86	PASS
	HCH	3.395	-47.992	-16.60	PASS
$\pi/4$ DQPSK	LCH	-2.620	-48.169	-22.62	PASS
	MCH	-1.813	-48.239	-21.81	PASS
	HCH	-2.817	-49.283	-22.82	PASS
8DPSK	LCH	-2.570	-49.111	-22.57	PASS
	MCH	-1.706	-48.206	-21.71	PASS
	HCH	-2.725	-45.635	-22.73	PASS



GFSK\_LCH\_Graphs

Pref

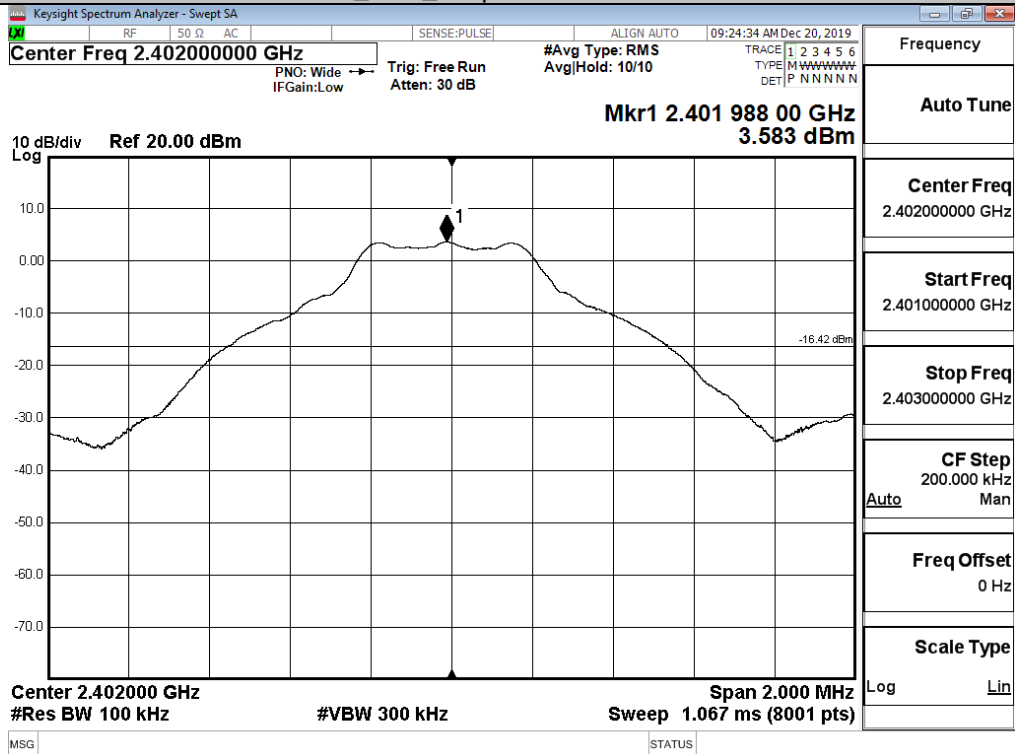

Puw

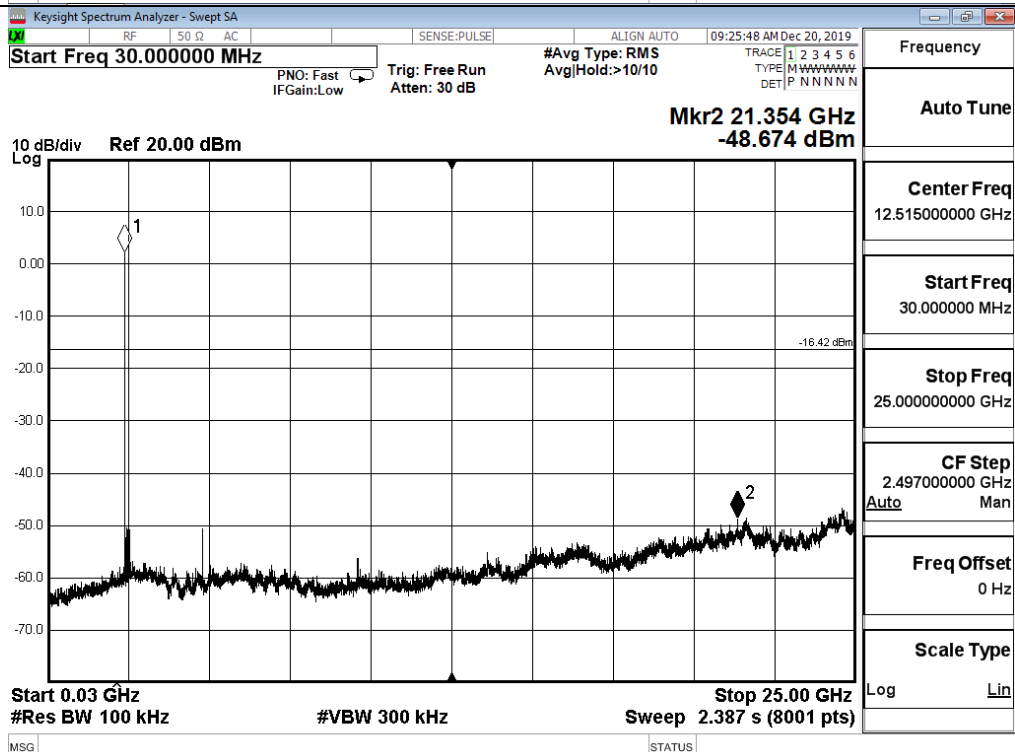

GFSK\_MCH\_Graphs

Pref

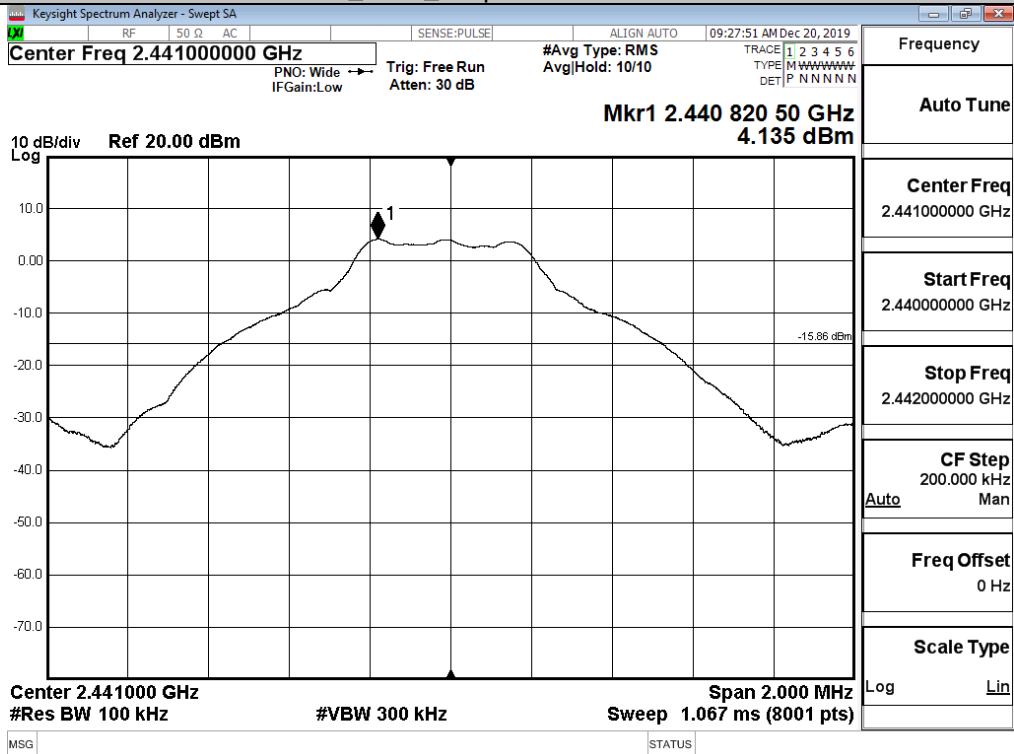

Puw

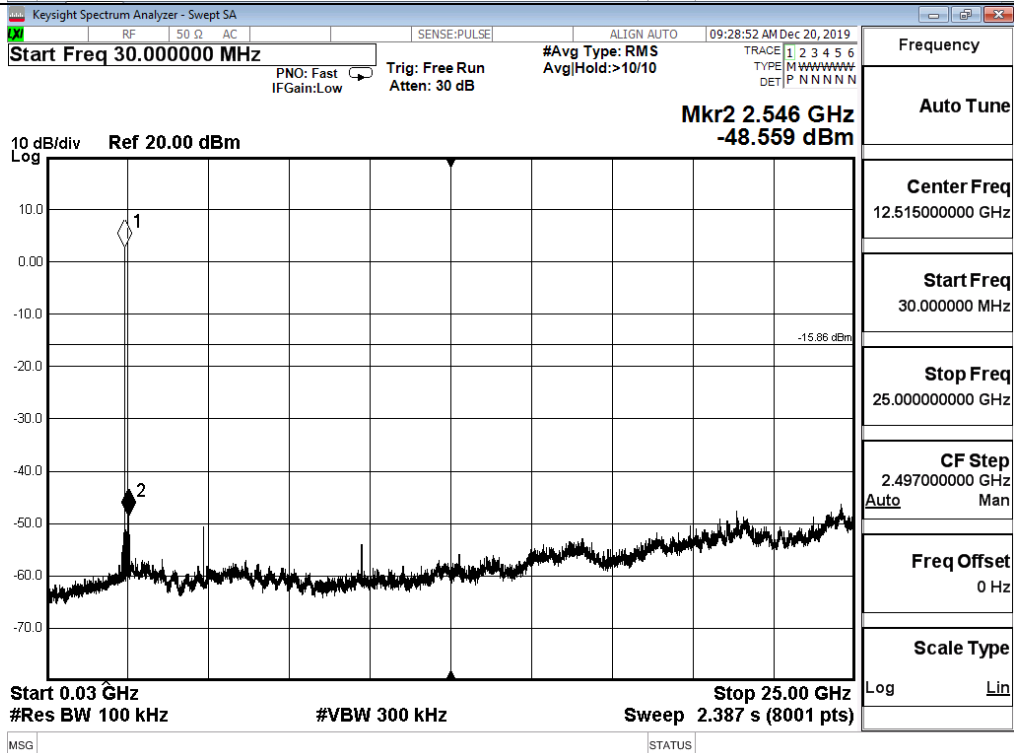

GFSK\_HCH\_Graphs

Pref

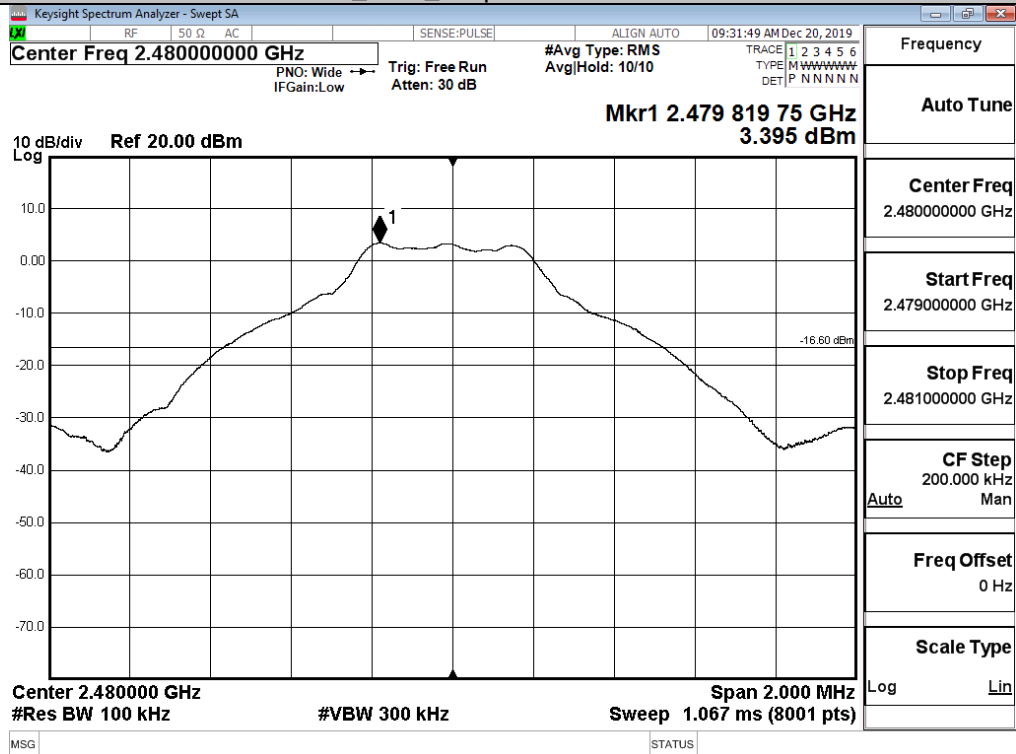

Puw

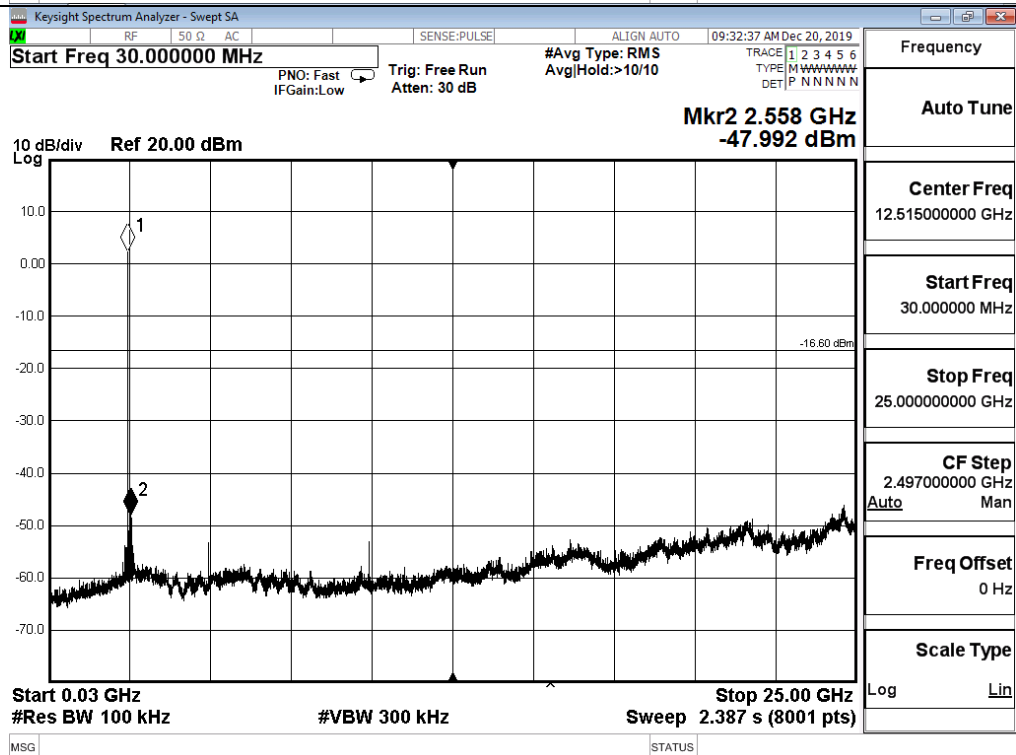

$\pi/4$ DQPSK\_LCH\_Graphs

Pref

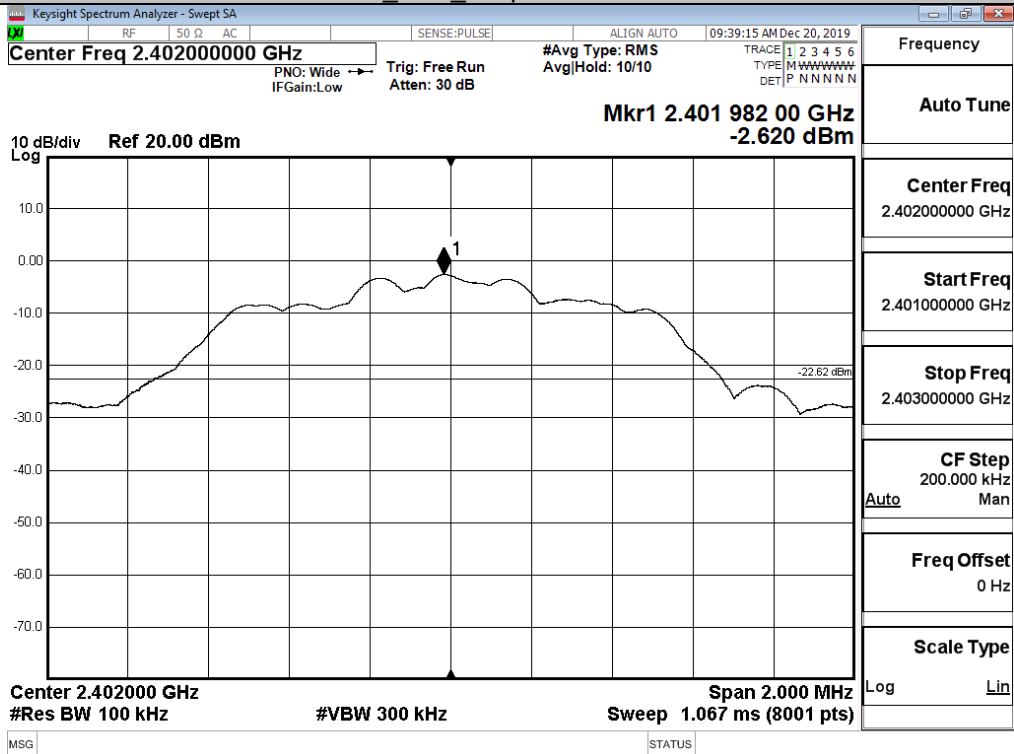

Puw

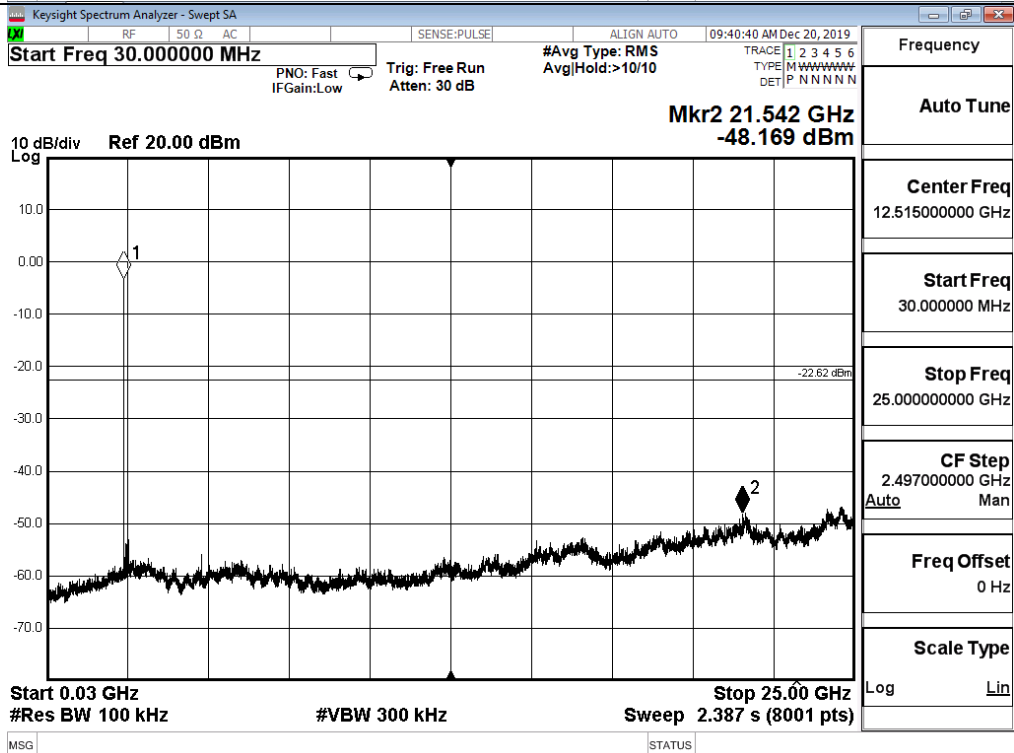

$\pi/4$ DQPSK\_MCH\_Graphs

Pref

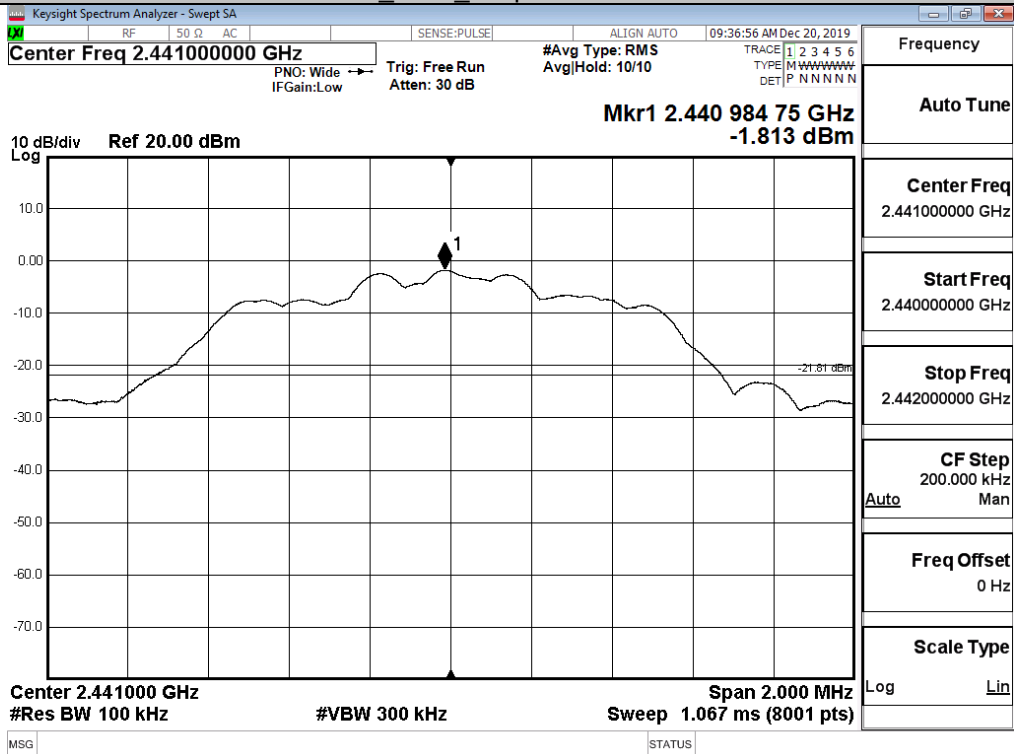

Puw

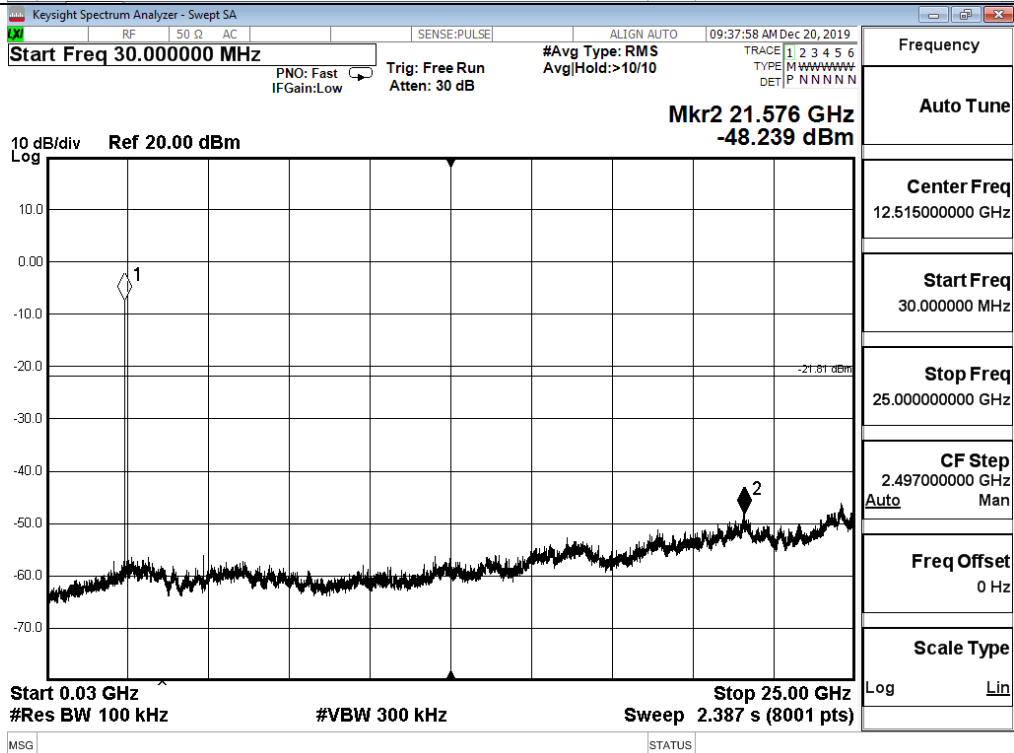

$\pi/4$ DQPSK\_HCH\_Graphs

Pref

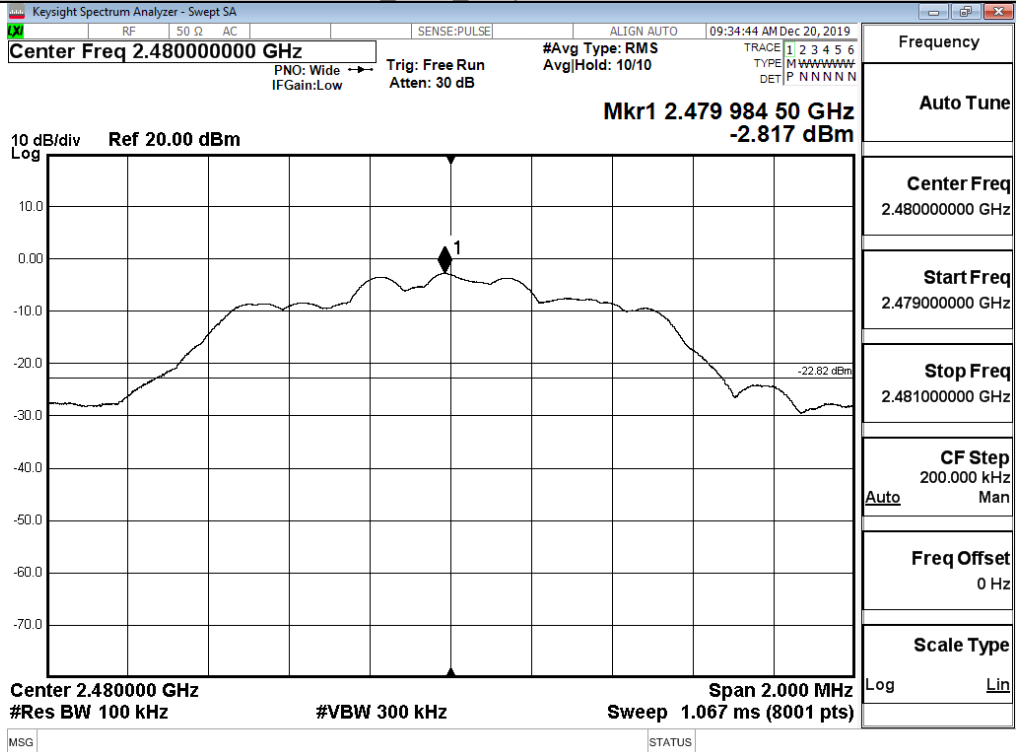

Puw

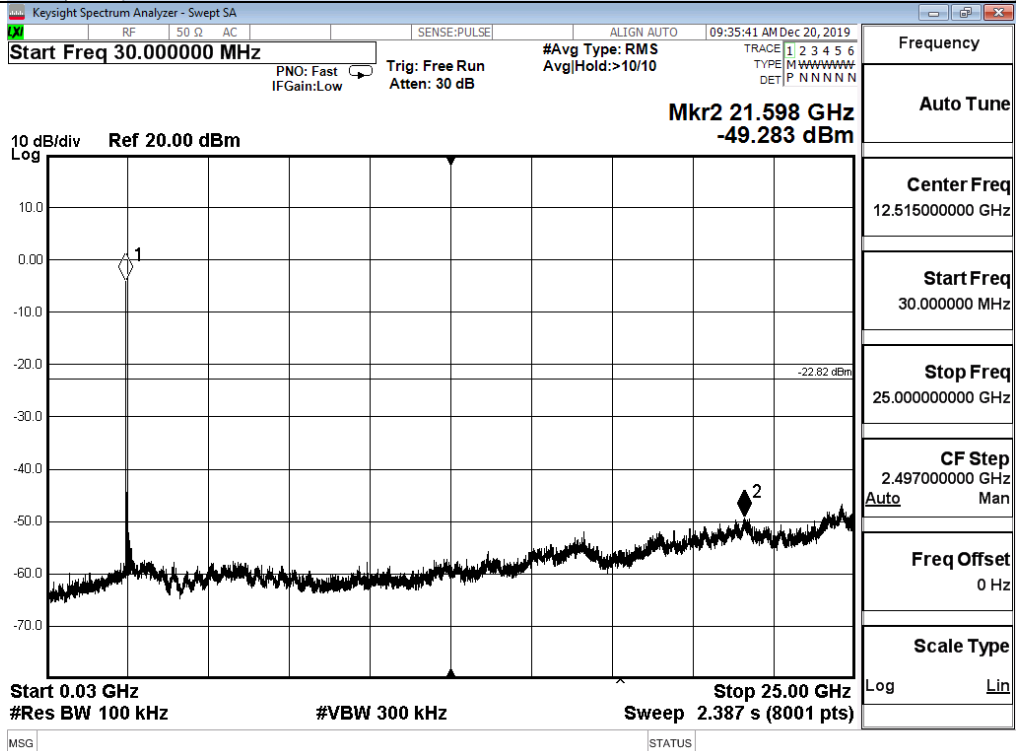

8DPSK\_LCH\_Graphs

Pref

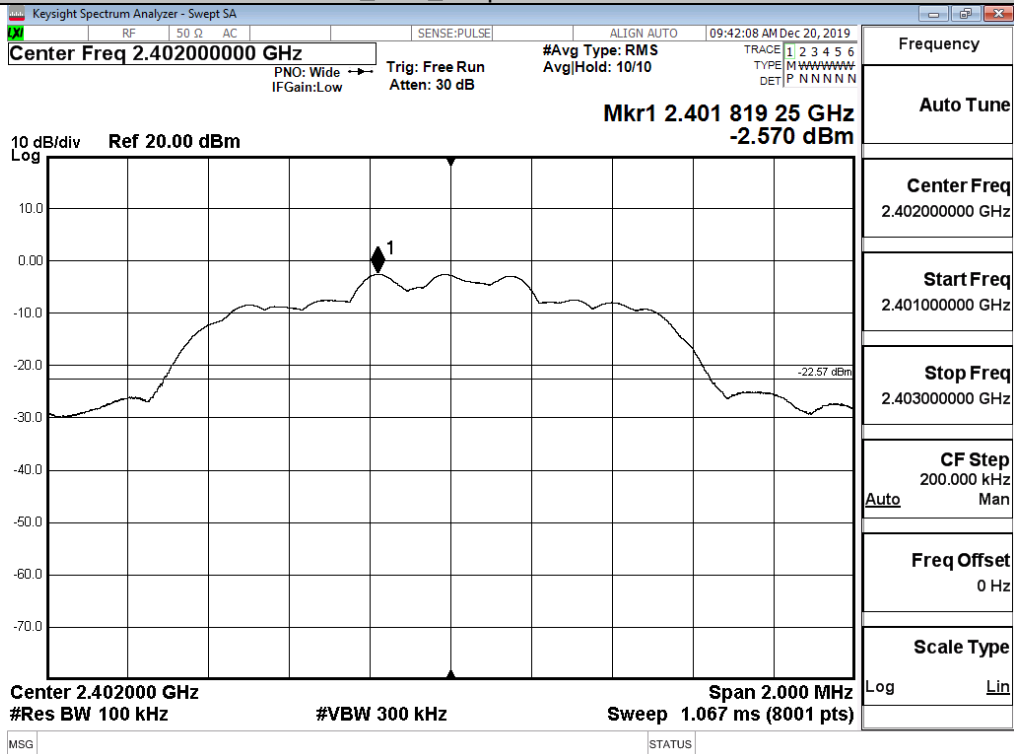

Puw

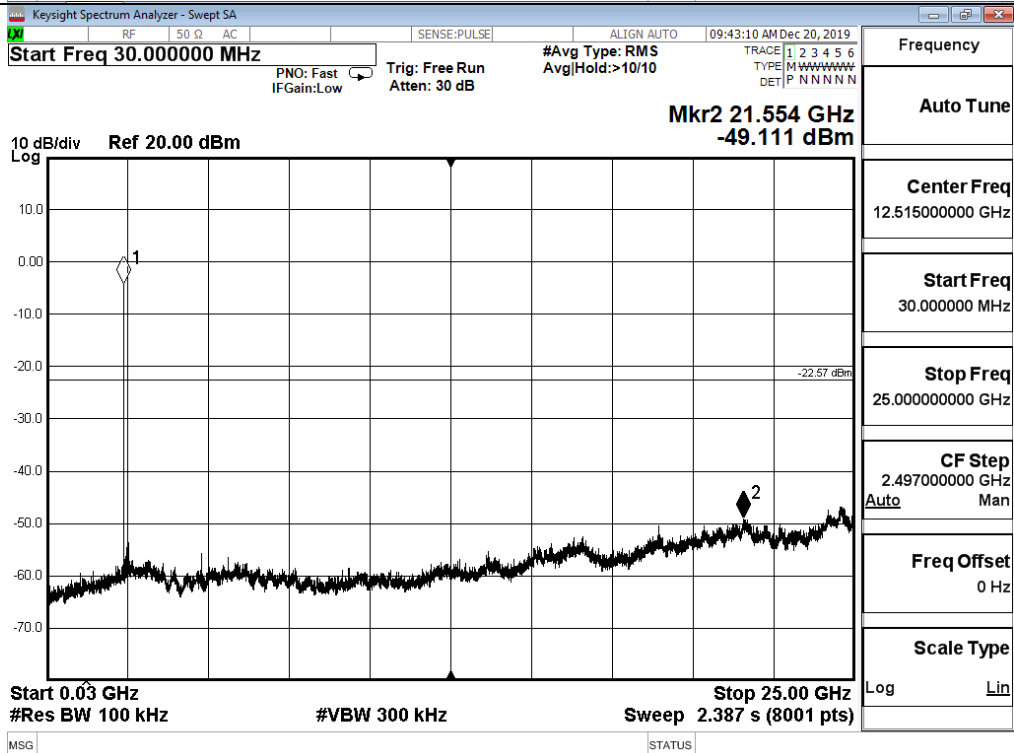

8DPSK\_MCH\_Graphs

Pref

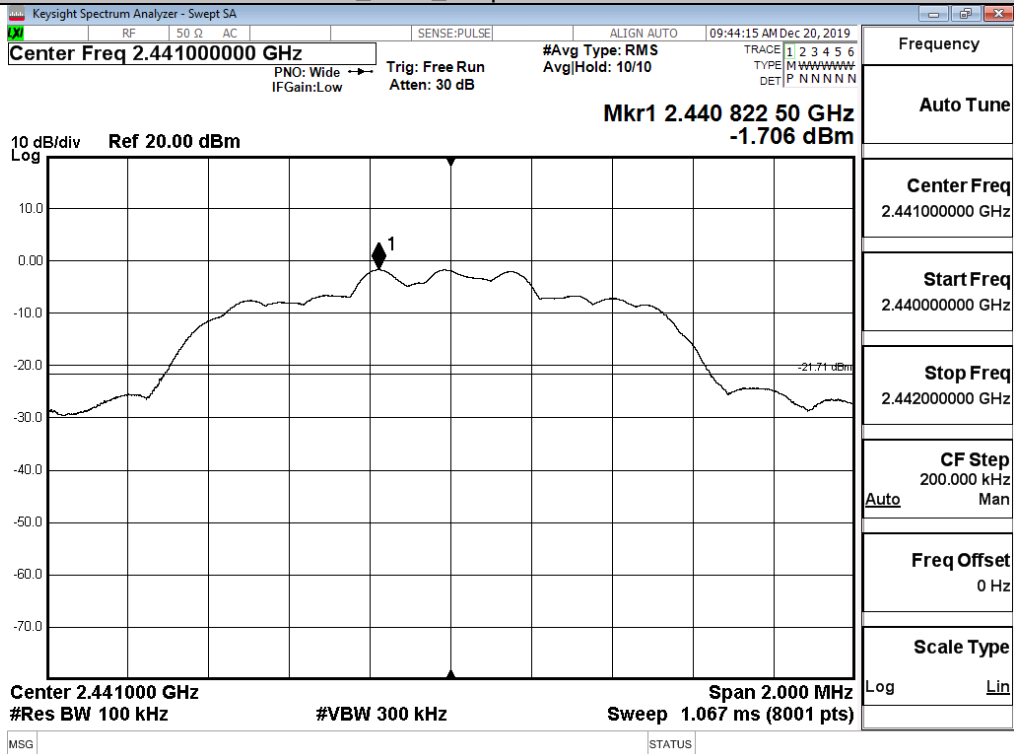

Puw

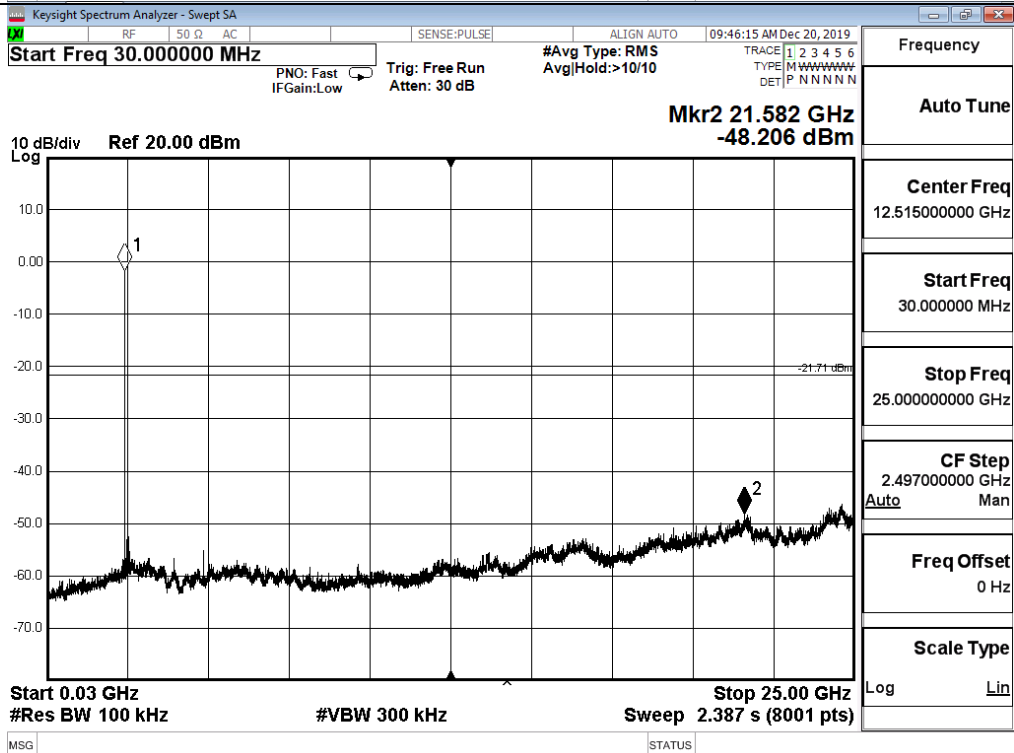



8DPSK\_HCH\_Graphs

Pref

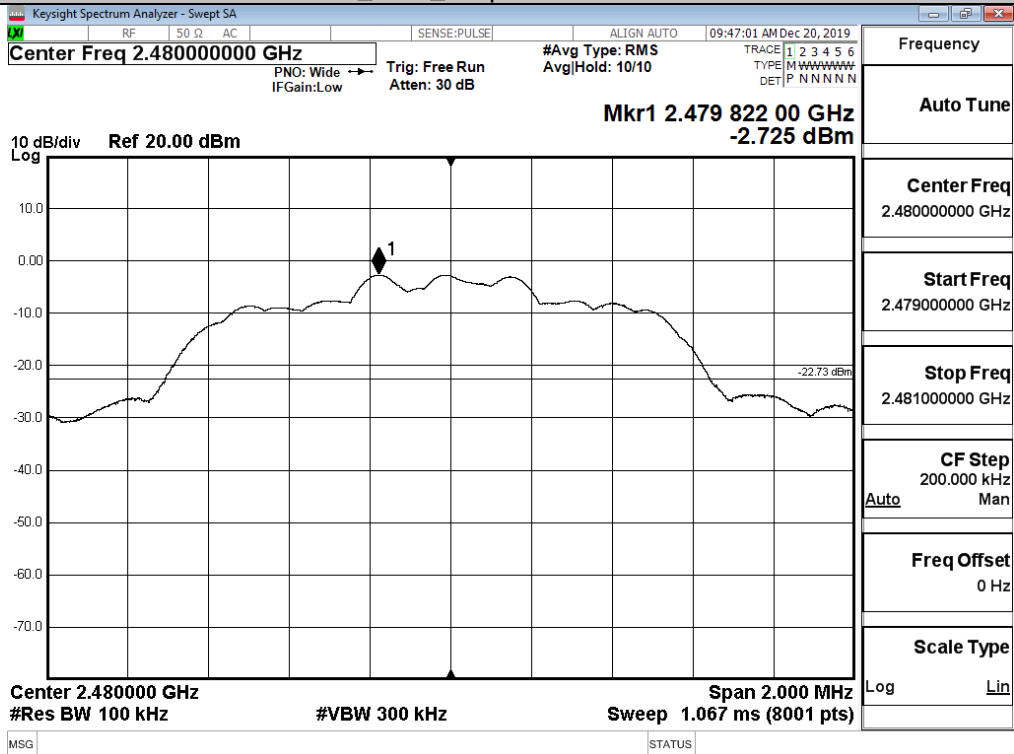

Puw

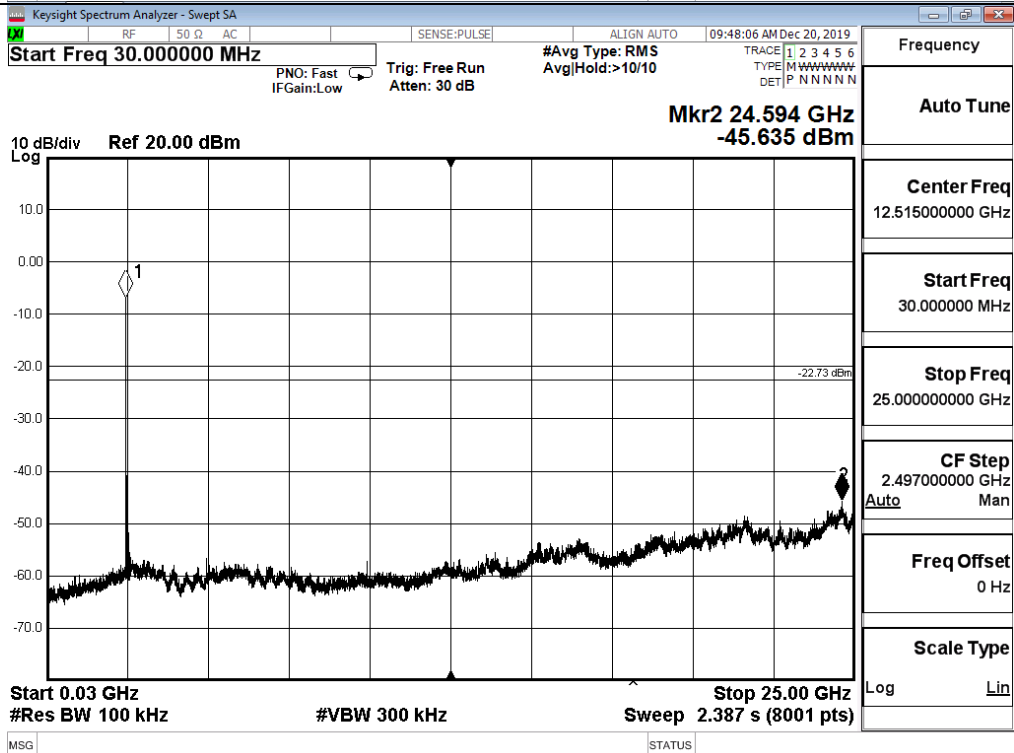

## A.7 Band-edge for RF Conducted Emissions

Mode	Channel	Carrier Frequency [MHz]	Carrier Power [dBm]	Frequency Hopping	Max Spurious Level [dBm]	Limit [dBm]	Verdict
GFSK	LCH	2402	3.630	Off	-54.693	-16.37	PASS
			3.586	On	-50.809	-16.41	PASS
	HCH	2480	3.445	Off	-57.621	-16.55	PASS
			3.254	On	-48.239	-16.75	PASS
$\pi/4$ DQPSK	LCH	2402	-2.437	Off	-57.736	-22.44	PASS
			-2.591	On	-55.775	-22.59	PASS
	HCH	2480	-2.735	Off	-57.700	-22.74	PASS
			-2.824	On	-51.902	-22.02	PASS
8DPSK	LCH	2402	-2.410	Off	-59.252	-22.41	PASS
			-2.556	On	-55.909	-22.59	PASS
	HCH	2480	-2.595	Off	-58.244	-22.60	PASS
			-2.683	On	-50.732	-22.68	PASS

Test Graphs

GFSK/LCH/No Hop

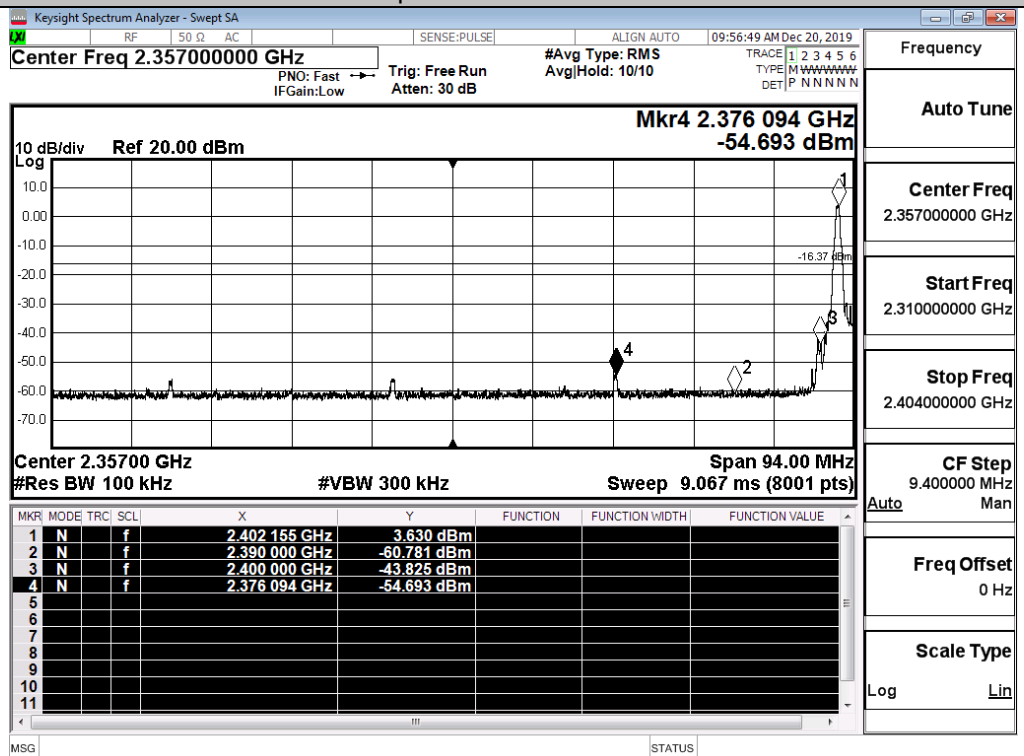

GFSK/LCH/Hop

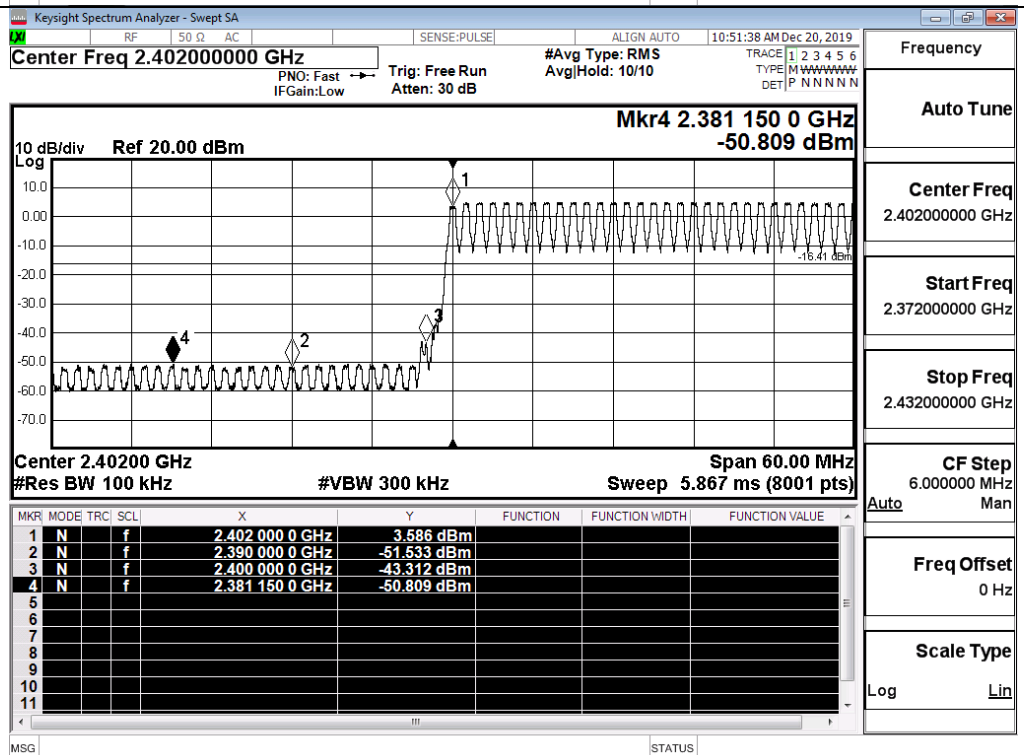

GFSK/HCH/No Hop

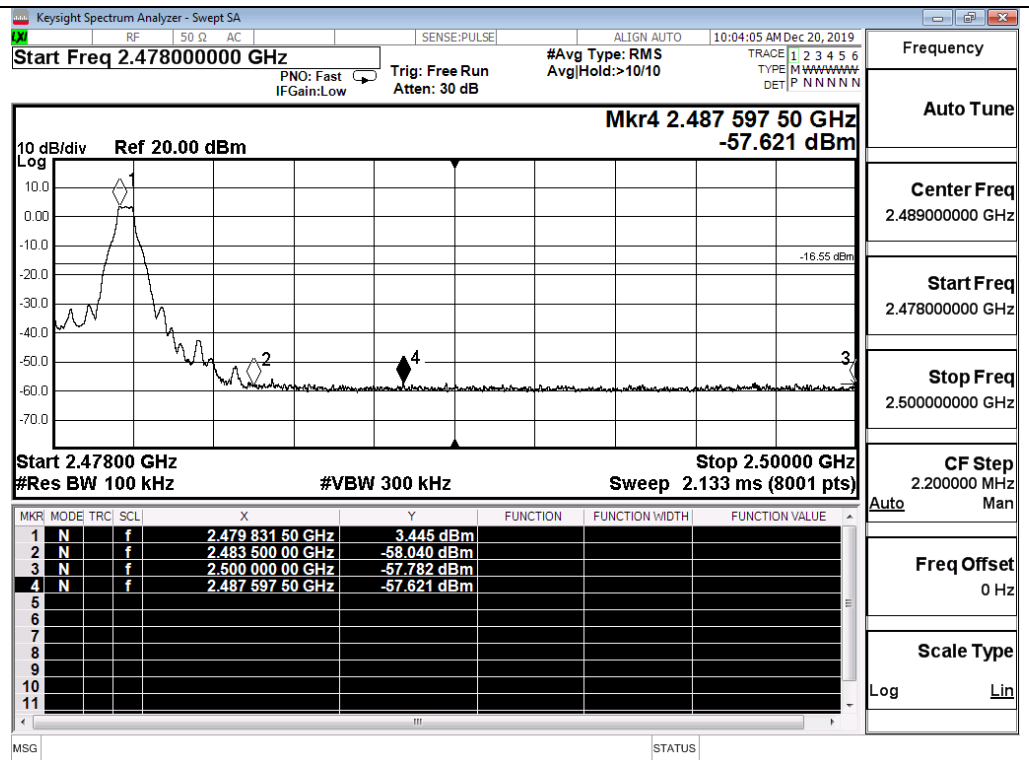

GFSK/HCH/Hop

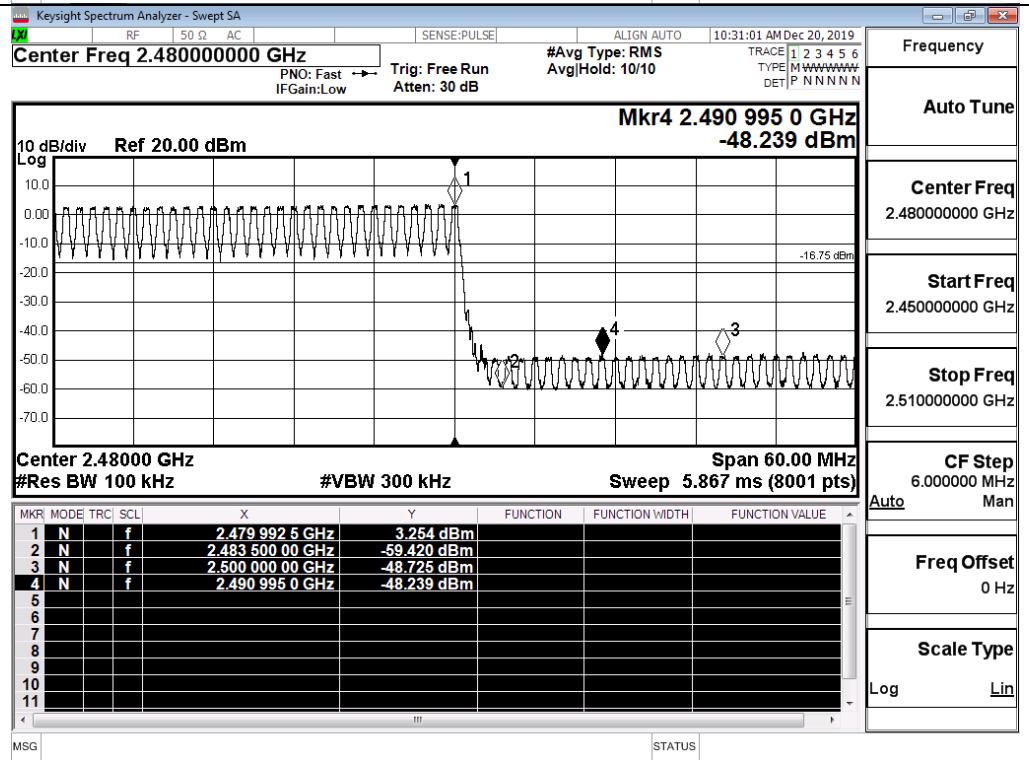

$\pi/4$ DQPSK/LCH/No  
Hop

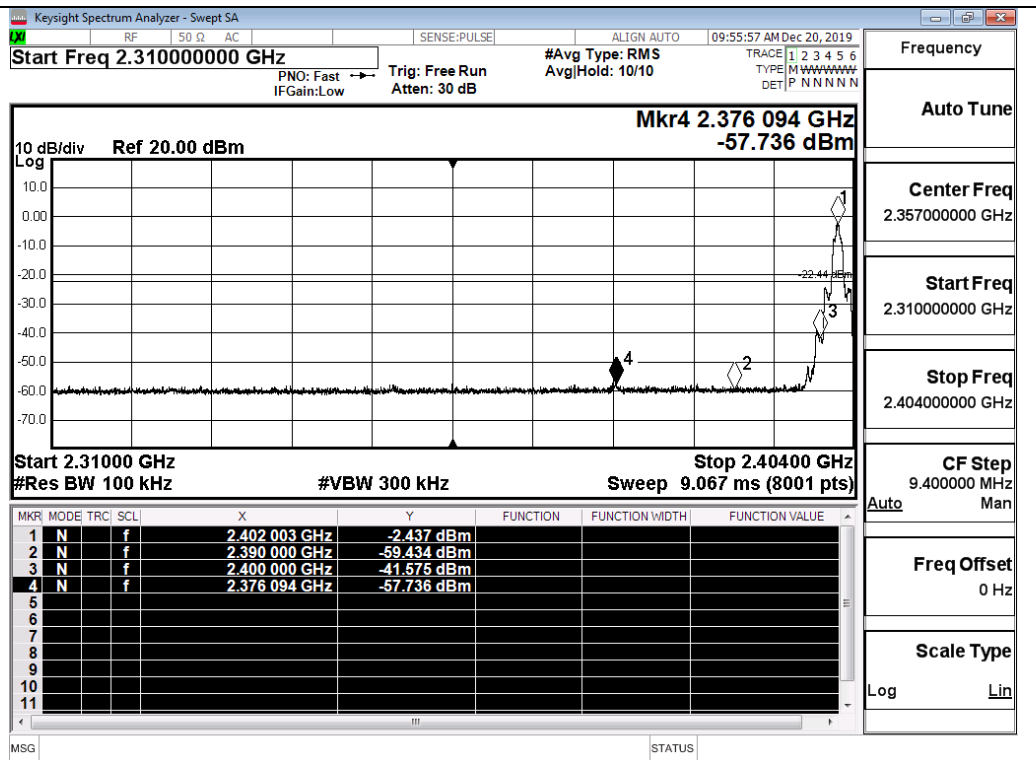

$\pi/4$ DQPSK/LCH/Hop

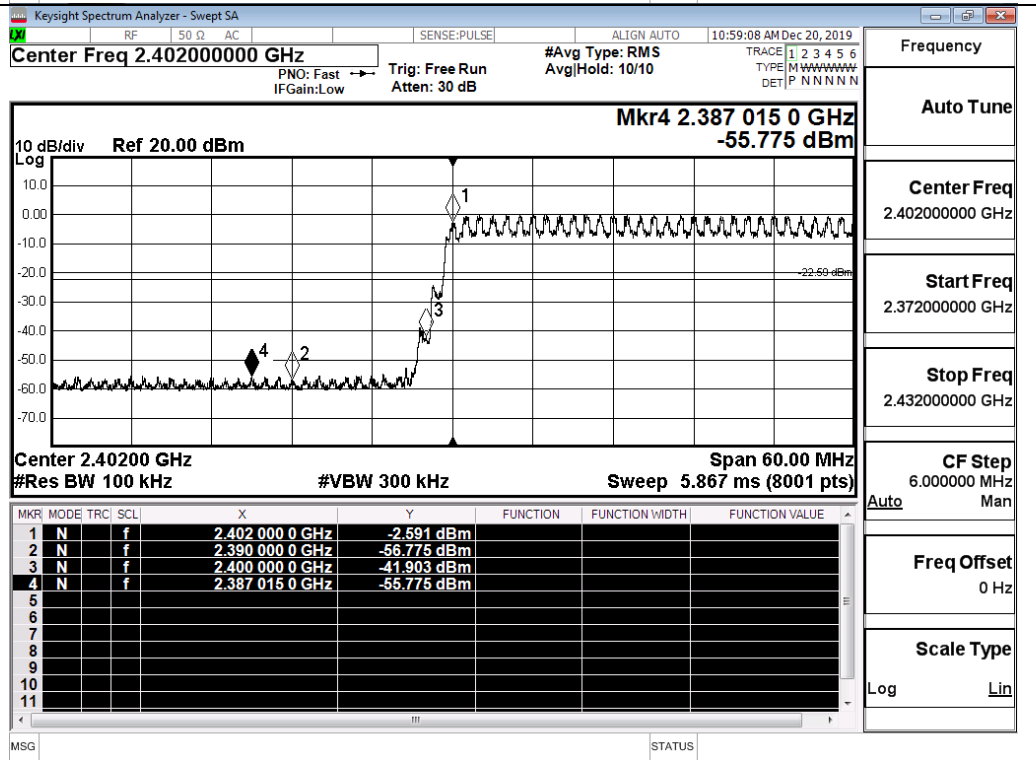

$\pi$ /4DQPSK/HCH/No  
Hop

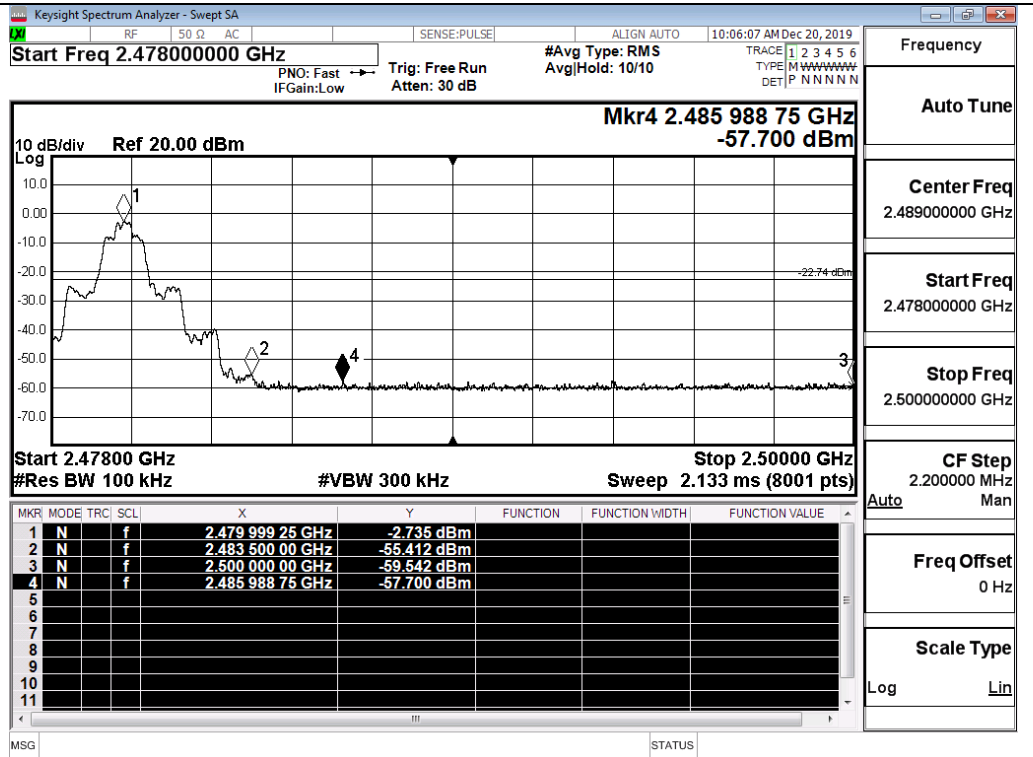

$\pi$ /4DQPSK/HCH/Hop

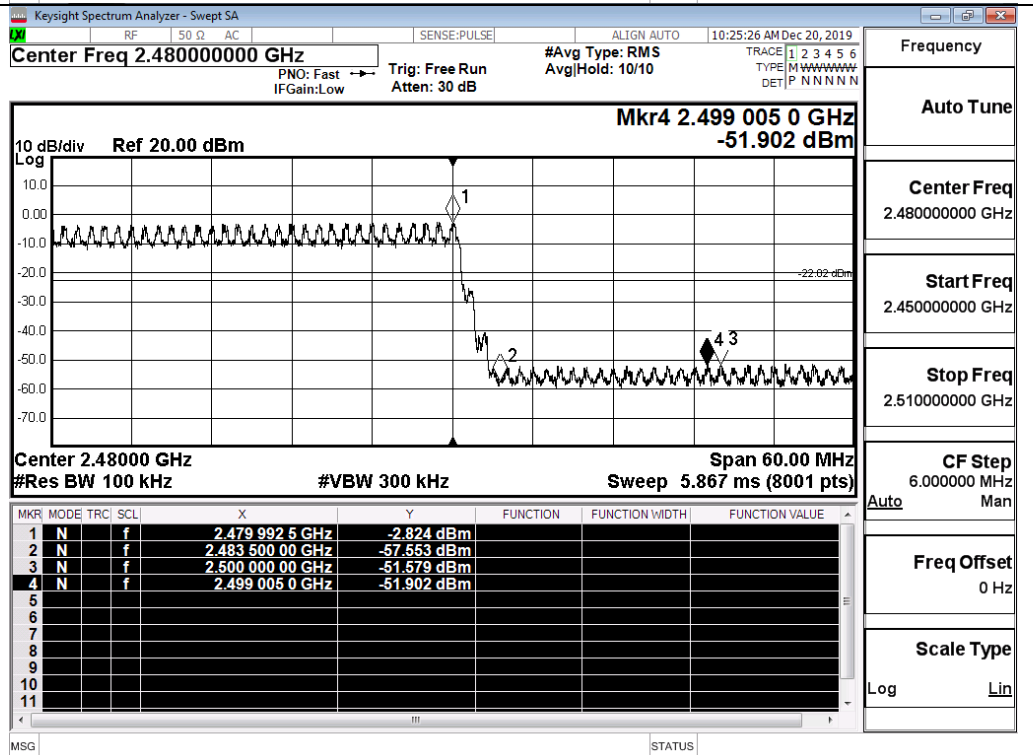

8DPSK/LCH/No Hop

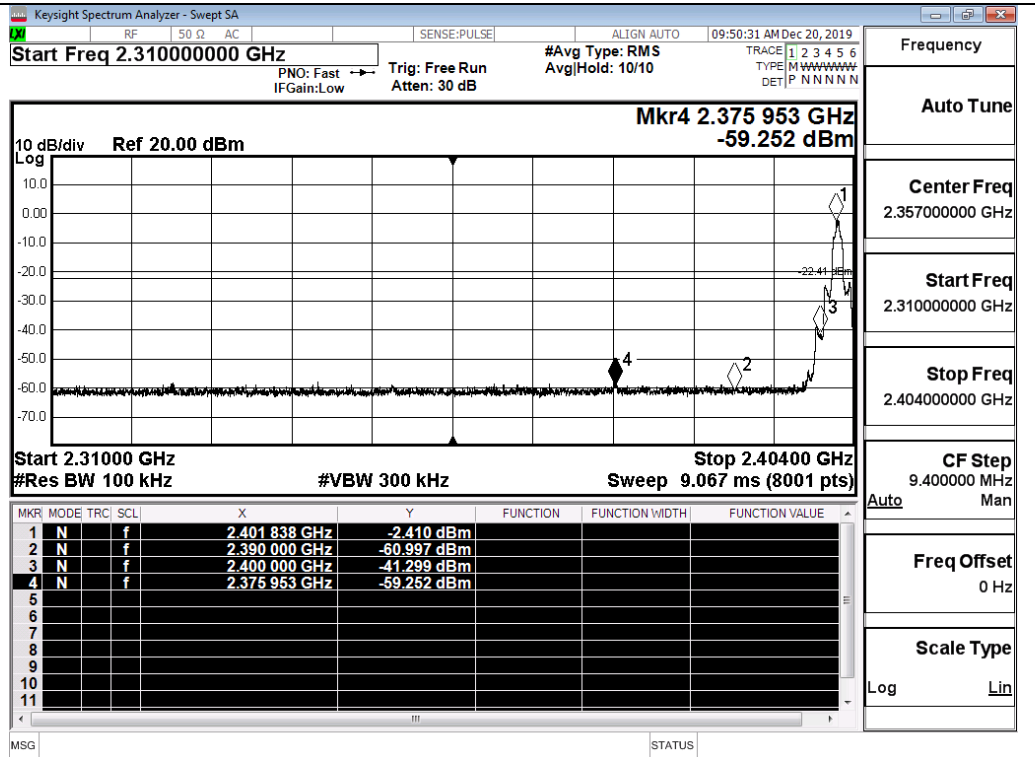

8DPSK/LCH/Hop

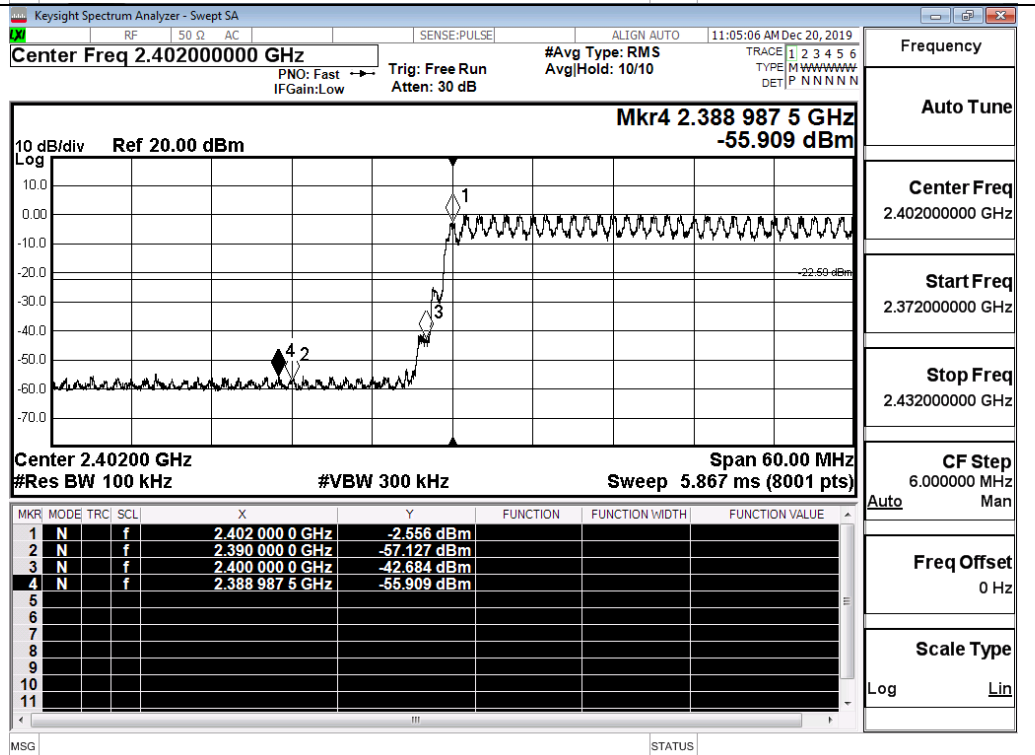

8DPSK/HCH/No Hop

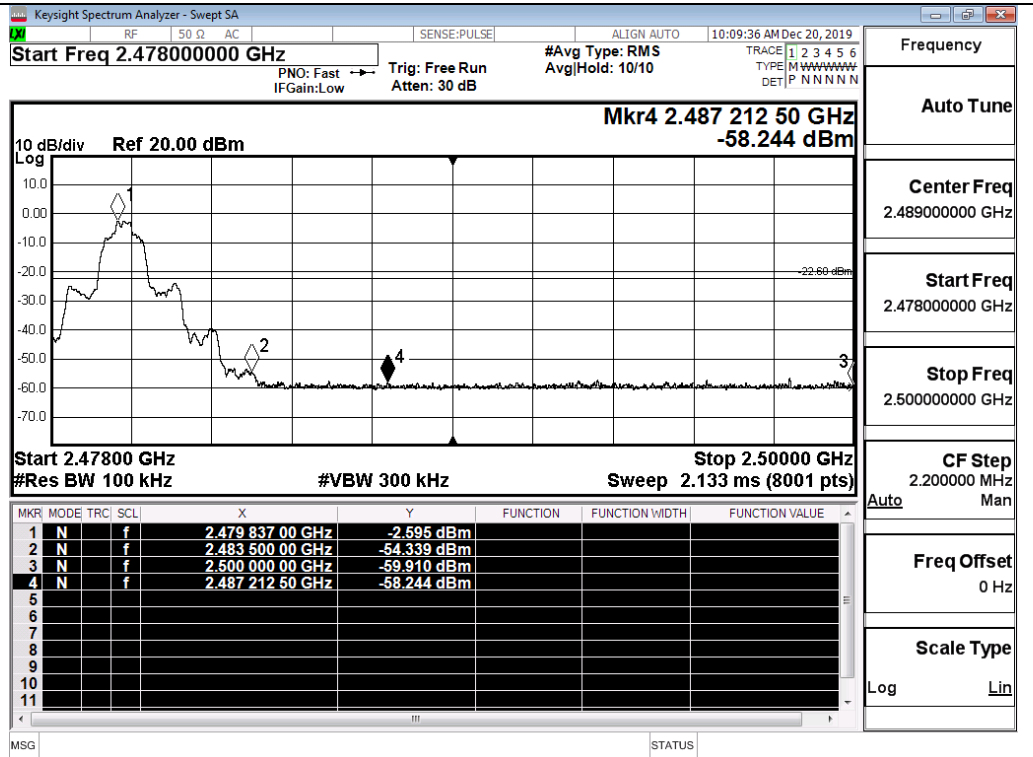

8DPSK/HCH/Hop

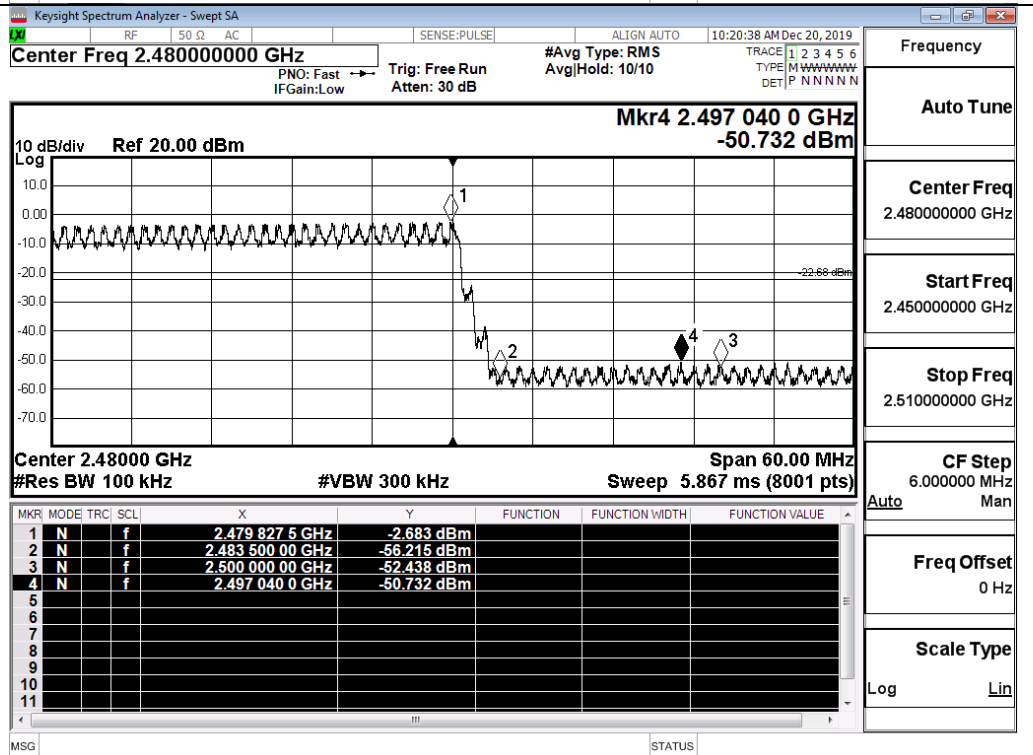



## A.8 Restrict-band band-edge measurements

Test Mode	Hopping	Freq.	Power [dBm]	Gain	Ground Factor	E [dBuV/m]	Detector	Limit [dBuV/m]	Verdict
GFSK	Off	2310.0	-50.147	2.0	0	47.11	PEAK	74	PASS
	Off	2310.0	-59.795	2.0	0	37.47	AV	54	PASS
	Off	2390.0	-51.754	2.0	0	45.51	PEAK	74	PASS
	Off	2390.0	-59.147	2.0	0	38.11	AV	54	PASS
	Off	2483.5	-49.723	2.0	0	47.54	PEAK	74	PASS
	Off	2483.5	-56.831	2.0	0	40.43	AV	54	PASS
	Off	2500.0	-50.607	2.0	0	46.65	PEAK	74	PASS
	Off	2500.0	-58.617	2.0	0	38.64	AV	54	PASS
$\pi/4$ DQPSK	Off	2310.0	-51.054	2.0	0	46.21	PEAK	74	PASS
	Off	2310.0	-59.898	2.0	0	37.36	AV	54	PASS
	Off	2390.0	-51.577	2.0	0	45.68	PEAK	74	PASS
	Off	2390.0	-59.361	2.0	0	37.90	AV	54	PASS
	Off	2483.5	-44.173	2.0	0	53.09	PEAK	74	PASS
	Off	2483.5	-54.816	2.0	0	42.44	AV	54	PASS
	Off	2500.0	-50.671	2.0	0	46.59	PEAK	74	PASS
	Off	2500.0	-58.899	2.0	0	38.36	AV	54	PASS
8DPSK	Off	2310.0	-52.504	2.0	0	44.76	PEAK	74	PASS
	Off	2310.0	-59.830	2.0	0	37.43	AV	54	PASS
	Off	2390.0	-51.219	2.0	0	46.04	PEAK	74	PASS
	Off	2390.0	-59.274	2.0	0	37.99	AV	54	PASS
	Off	2483.5	-44.222	2.0	0	53.04	PEAK	74	PASS
	Off	2483.5	-54.927	2.0	0	42.33	AV	54	PASS
	Off	2500.0	-50.245	2.0	0	47.02	PEAK	74	PASS
	Off	2500.0	-58.681	2.0	0	38.58	AV	54	PASS

Restrict-band band-edge measurements\_Hopping Off\_GFSK\_PEAK (Low Channel)

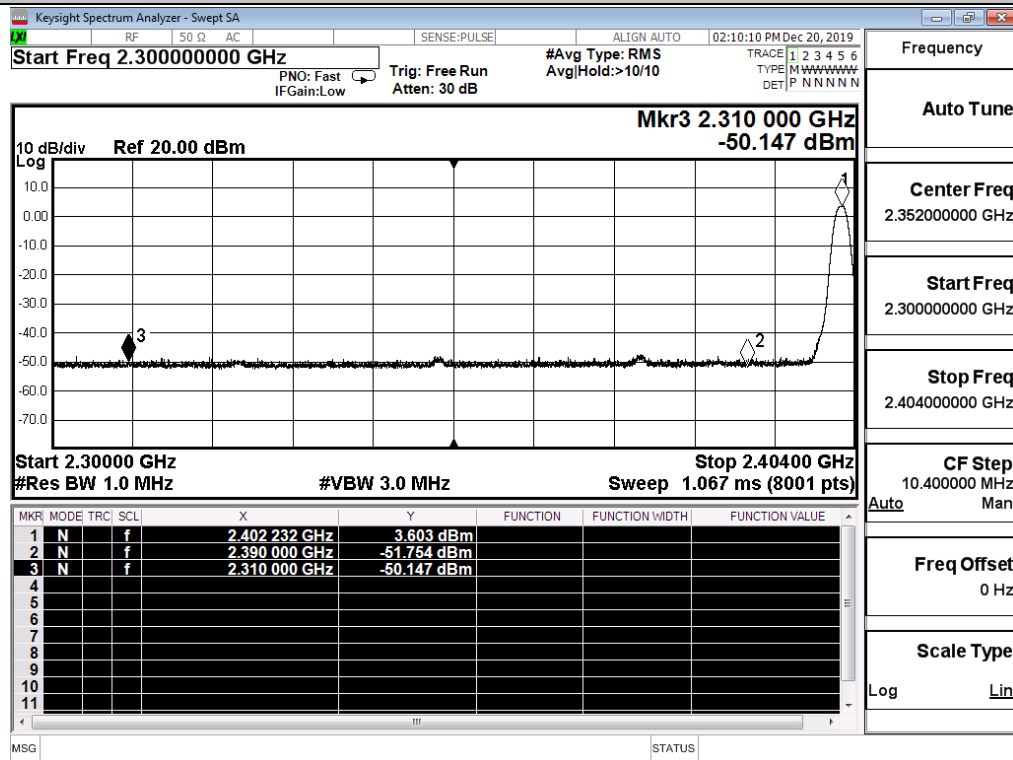

Restrict-band band-edge measurements\_Hopping Off\_GFSK\_Average (Low Channel)

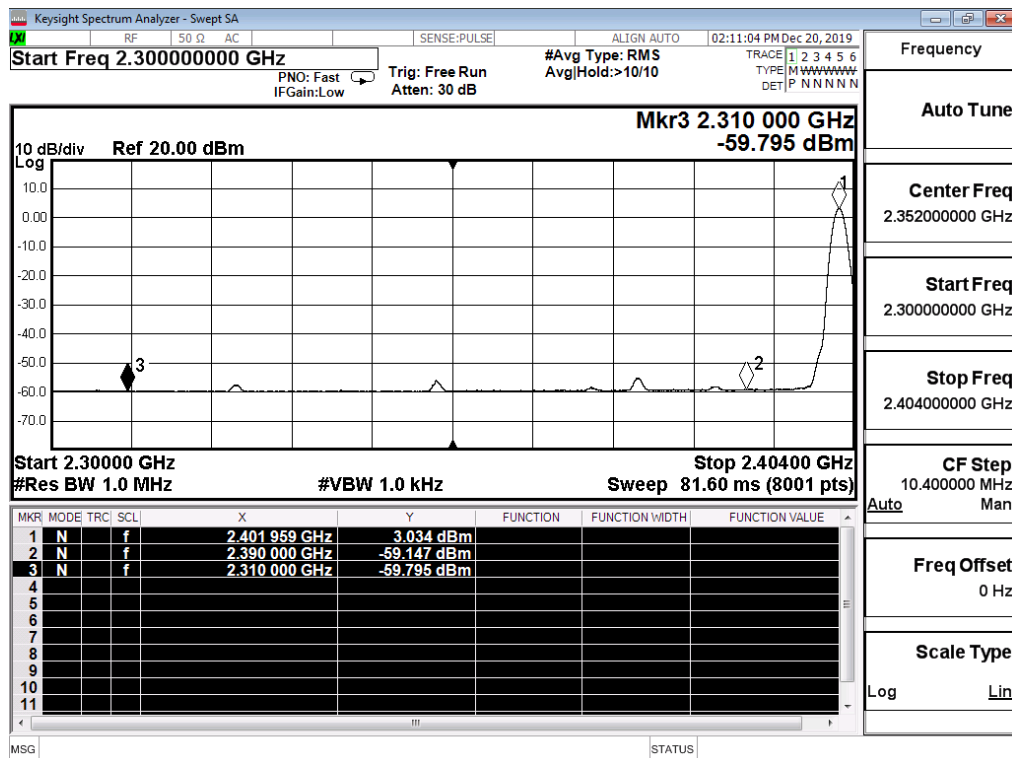

Restrict-band band-edge measurements\_Hopping Off\_GFSK\_PEAK (High Channel)

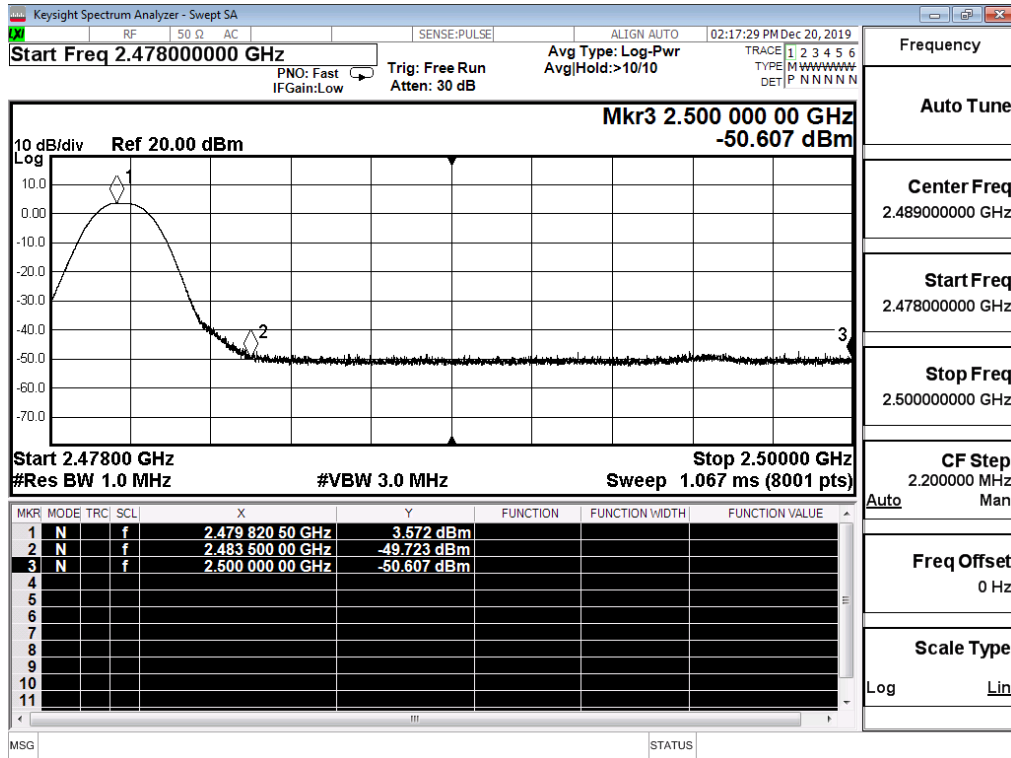

Restrict-band band-edge measurements\_Hopping Off\_GFSK\_Average (High Channel)

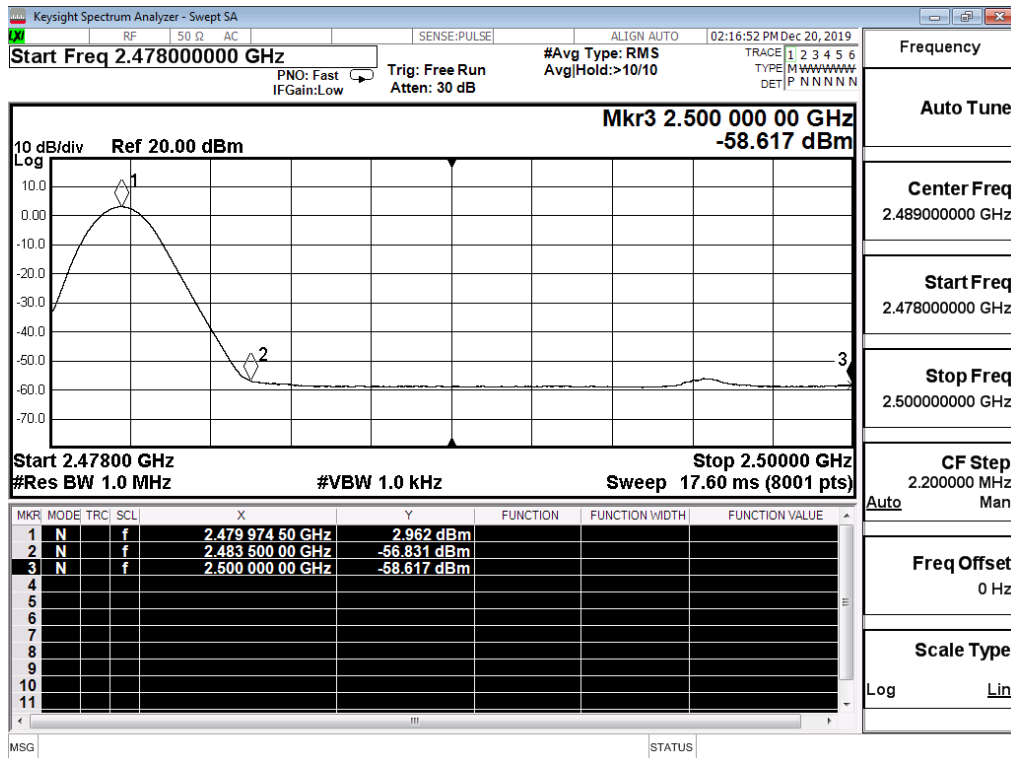

Restrict-band band-edge measurements\_Hopping Off  $\pi/4$ -DQPSK\_PEAK (Low Channel)

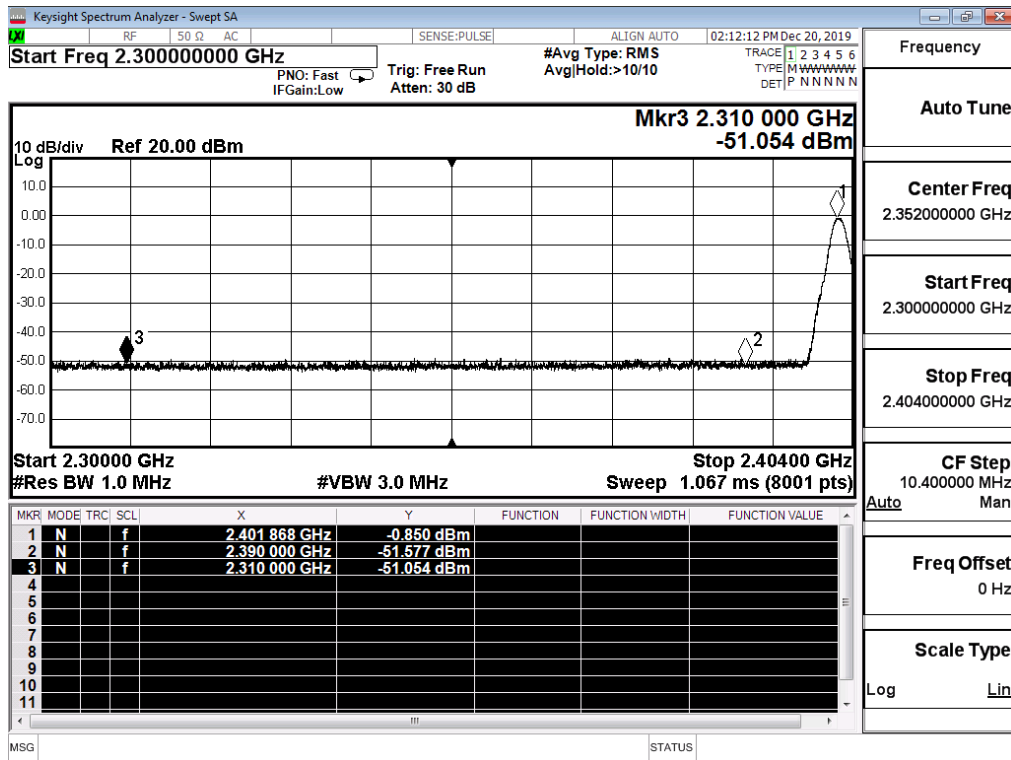

Restrict-band band-edge measurements\_Hopping Off  $\pi/4$ -DQPSK\_Average (Low Channel)

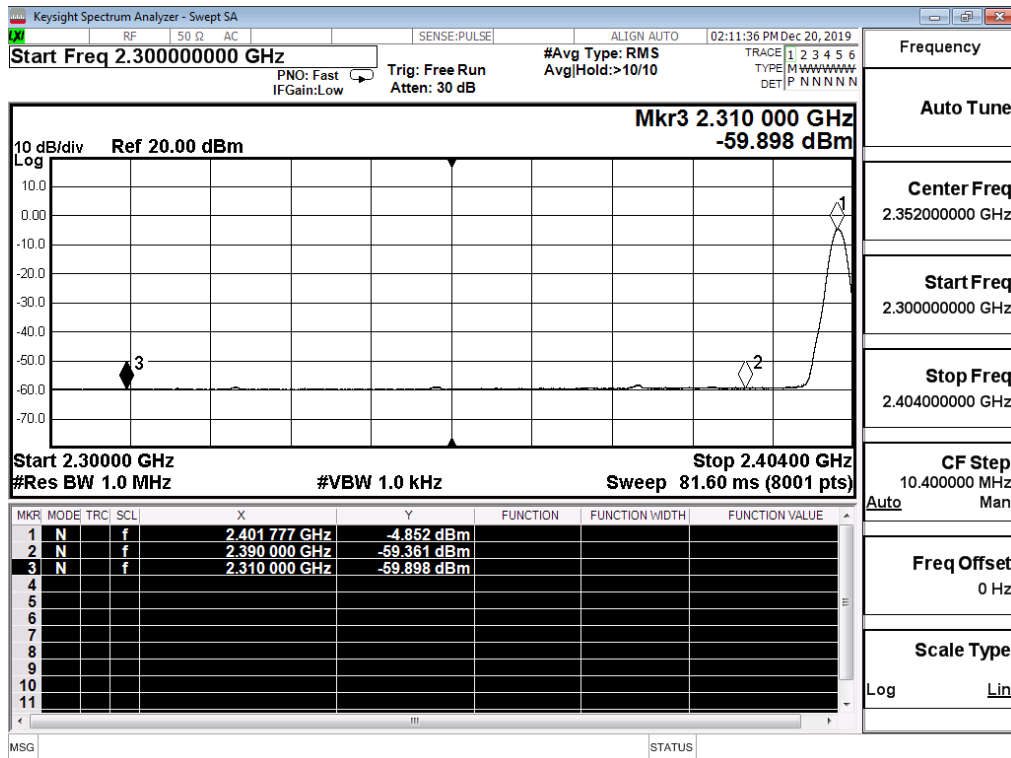

Restrict-band band-edge measurements\_Hopping Off  $\pi/4$ -DQPSK\_PEAK (High Channel)

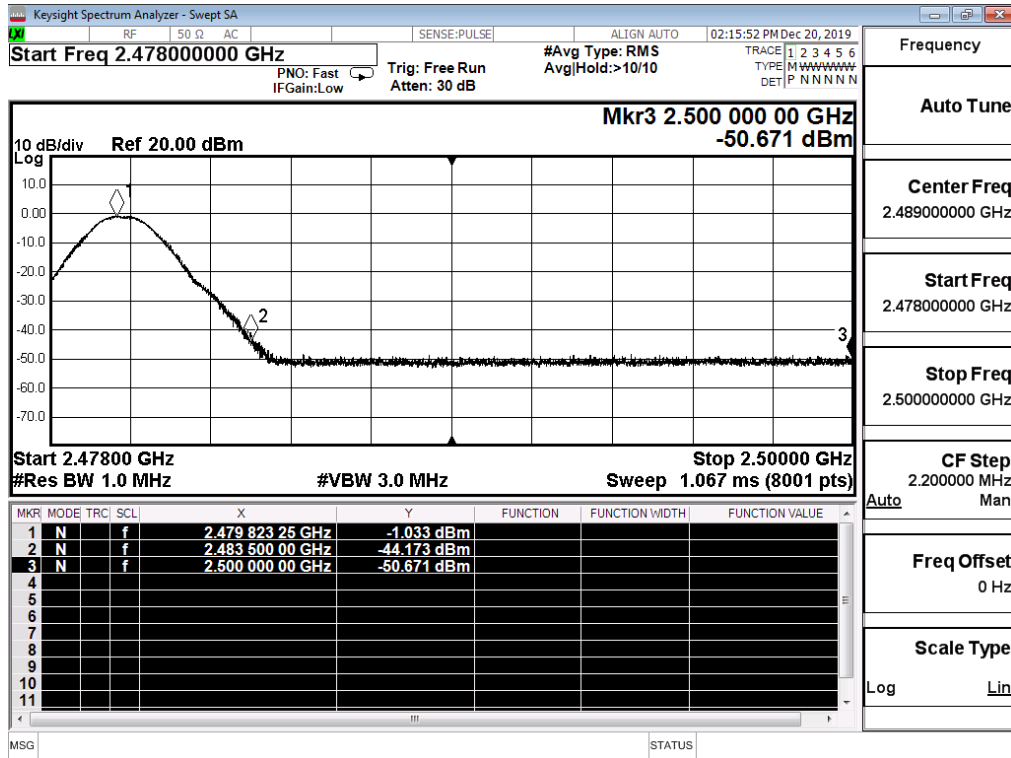

Restrict-band band-edge measurements\_Hopping Off  $\pi/4$ -DQPSK\_Average (High Channel)

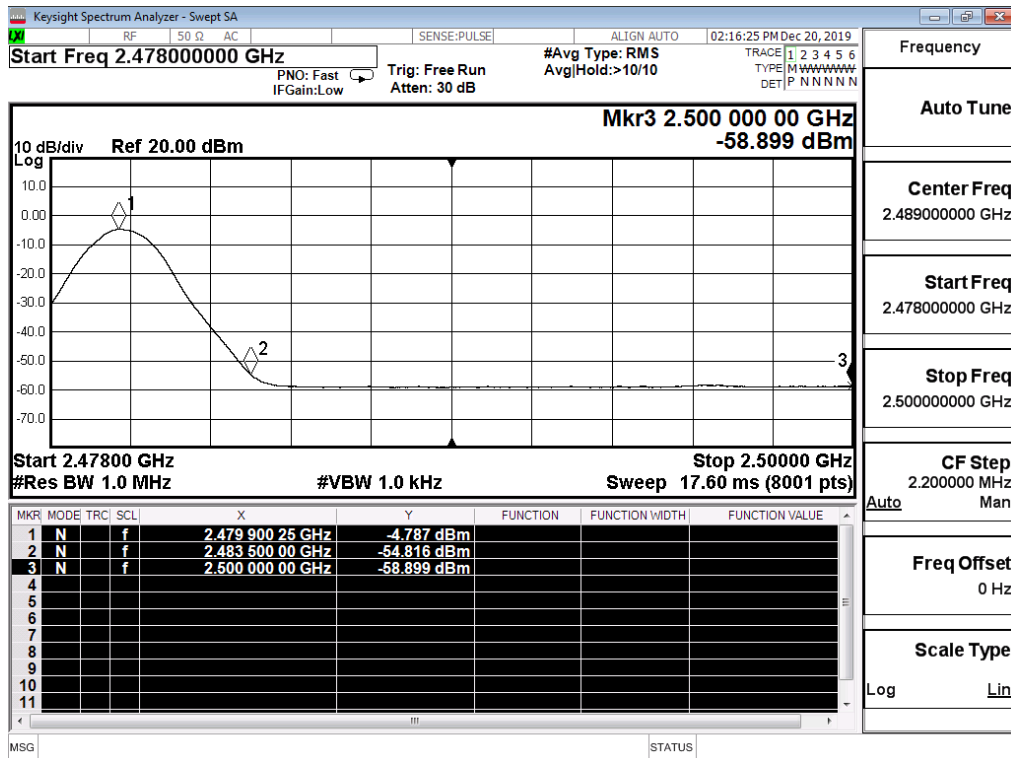

Restrict-band band-edge measurements\_Hopping Off\_8DPSK\_PEAK (Low Channel)

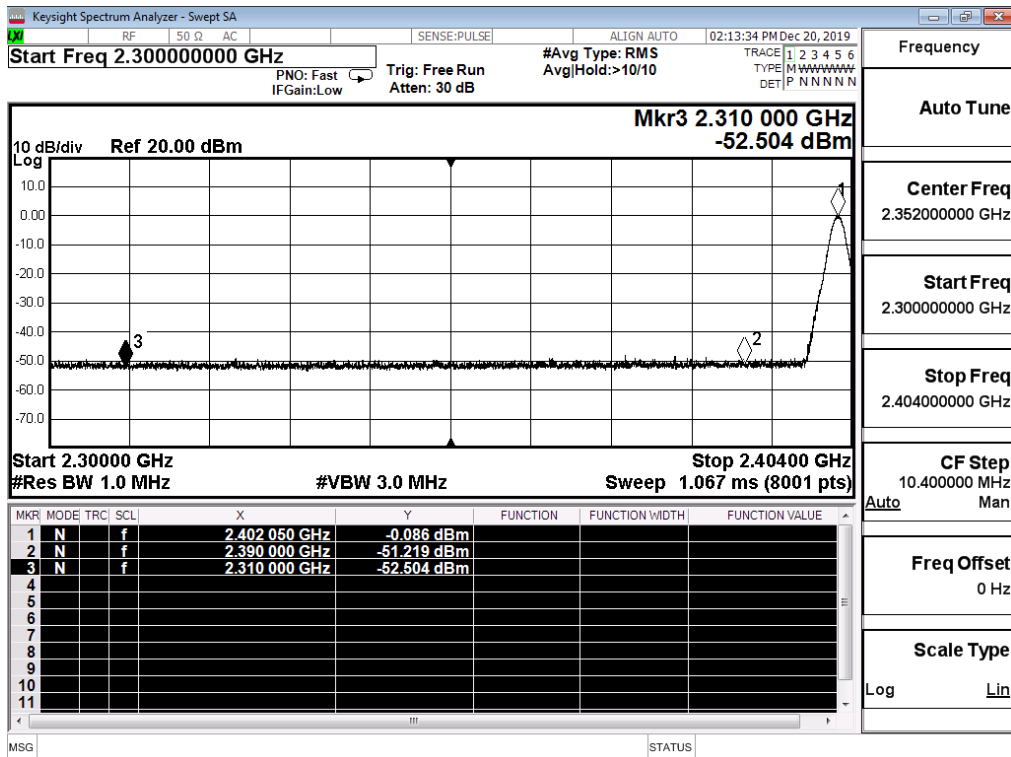

Restrict-band band-edge measurements\_Hopping Off\_8DPSK\_Average (Low Channel)

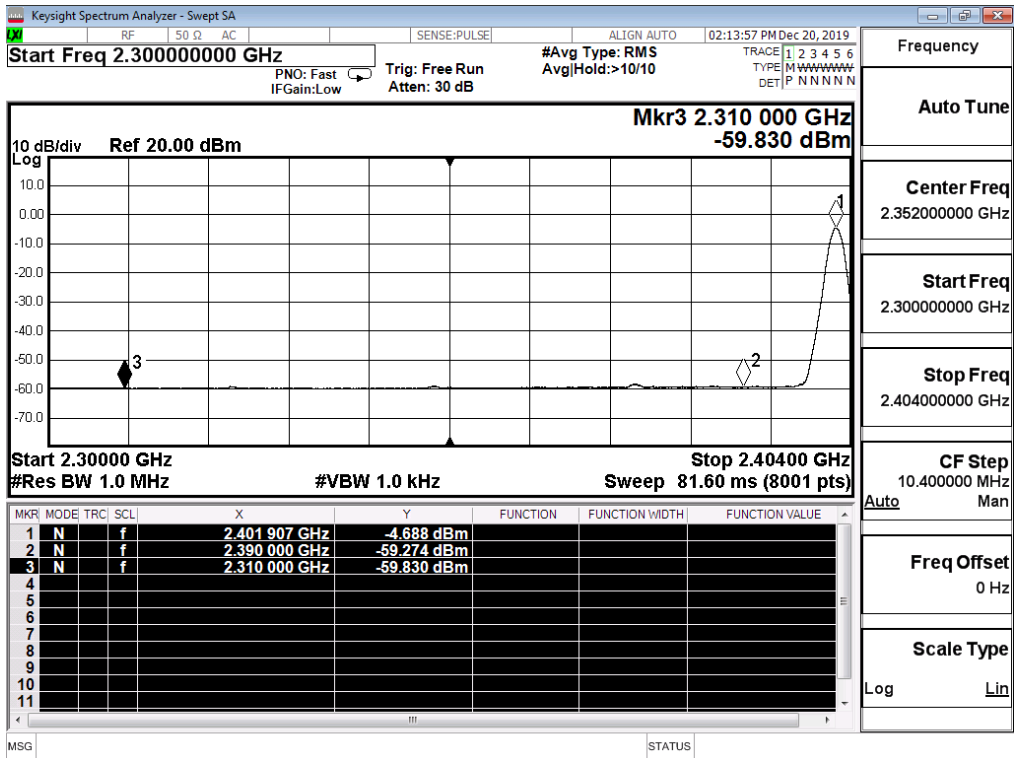

Restrict-band band-edge measurements\_Hopping Off\_8DPSK\_PEAK (High Channel)

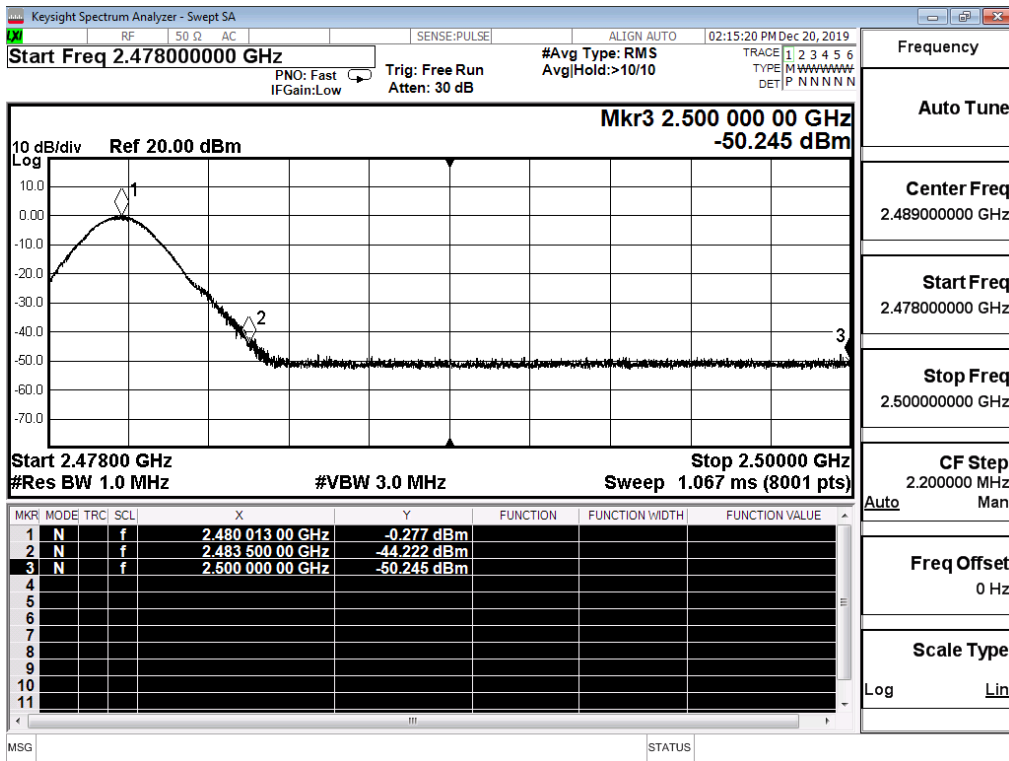

Restrict-band band-edge measurements\_Hopping Off\_8DPSK\_Average (High Channel)

