

Product Name: Computer	Report No: FCC022023-0289RF6
Product Model: IPASONS6-X7004457152	Security Classification: Open
Version: V1.0	Total Page: 73

TIRT Testing Report



Prepared By:	Checked By:	Approved By:	
Stone Tang	Randy Lv	Daniel Chen	
<i>Stone Tang</i>	<i>Randy Lv</i>	<i>Daniel chen</i>	

FCC Radio Test Report

FCC ID: 2ATY8-IPASONS6

This report concerns: Original Grant

Equipment : Computer
Brand Name : **IPASON**
Test Model : IPASONS6-X7004457152
Series Model : IPASONS6***** (* can be 0-9,a-z,A-Z or "-")
Applicant : Wuhan Ipson Technology Co., Ltd
Address : 5th Floor, Multifunctional Building, No. 1, Ipson Avenue, Shekou Street, Huangpi District, Wuhan City, Hubei Province, China
Manufacturer : Wuhan Ipson Technology Co., Ltd
Address : 5th Floor, Multifunctional Building, No. 1, Ipson Avenue, Shekou Street, Huangpi District, Wuhan City, Hubei Province, China
Date of Receipt : Feb. 04, 2023
Date of Test : Feb. 06, 2023~ Mar. 20, 2023
Issued Date : Mar. 21, 2023
Report Version : V1.0
Test Sample : Engineering Sample No.: 20221103019324
Standard(s) : FCC CFR Title 47, Part 15, Subpart C
FCC KDB 558074 D01 15.247 Meas Guidance v05r02
ANSI C63.10-2013

- The test result referred exclusively to the presented test model /sample.
- Without written approval of TIRT Inc. the test report shall not reproduced except in full.

Lab: Beijing TIRT Technology Service Co.,Ltd Shenzhen

Add: 101, 3 # Factory Building, Gongjin Electronics Shatin Community, Kengzi Street, Pingshan

District, Shenzhen, China

TEL: +86-0755-27087573

Table of Contents**Page**

REPORT ISSUED HISTORY	6
1 . SUMMARY OF TEST RESULTS	7
1.1 TEST FACILITY	8
1.2 MEASUREMENT UNCERTAINTY	8
1.3 TEST ENVIRONMENT CONDITIONS	8
2 . GENERAL INFORMATION	9
2.1 GENERAL DESCRIPTION OF EUT	9
2.2 DESCRIPTION OF TEST MODES	11
2.3 PARAMETERS OF TEST SOFTWARE	12
2.4 BLOCK DIAGRAM SHOWING THE CONFIGURATION OF SYSTEM TESTED	13
2.5 SUPPORT UNITS	13
3 . AC POWER LINE CONDUCTED EMISSIONS	14
3.1 LIMIT	14
3.2 TEST PROCEDURE	14
3.3 DEVIATION FROM TEST STANDARD	14
3.4 TEST SETUP	15
3.5 EUT OPERATING CONDITIONS	15
3.6 TEST RESULTS	15
4 . RADIATED EMISSIONS	16
4.1 LIMIT	16
4.2 TEST PROCEDURE	17
4.3 DEVIATION FROM TEST STANDARD	18
4.4 TEST SETUP	18
4.5 EUT OPERATING CONDITIONS	20
4.6 TEST RESULTS - 9 KHZ TO 30 MHZ	20
4.7 TEST RESULTS - 30 MHZ TO 1000 MHZ	20
4.8 TEST RESULTS - ABOVE 1000 MHZ	20
5 . NUMBER OF HOPPING FREQUENCY	21
5.1 LIMIT	21
5.2 TEST PROCEDURE	21
5.3 DEVIATION FROM STANDARD	21
5.4 TEST SETUP	21
5.5 EUT OPERATION CONDITIONS	21
5.6 TEST RESULTS	21

Table of Contents	Page
6 . AVERAGE TIME OF OCCUPANCY	22
6.1 LIMIT	22
6.2 TEST PROCEDURE	22
6.3 DEVIATION FROM STANDARD	22
6.4 TEST SETUP	22
6.5 EUT OPERATION CONDITIONS	22
6.6 TEST RESULTS	22
7 . HOPPING CHANNEL SEPARATION	23
7.1 LIMIT	23
7.2 TEST PROCEDURE	23
7.3 DEVIATION FROM STANDARD	23
7.4 TEST SETUP	23
7.5 EUT OPERATION CONDITIONS	23
7.6 TEST RESULTS	23
8 . BANDWIDTH	24
8.1 LIMIT	24
8.2 TEST PROCEDURE	24
8.3 DEVIATION FROM STANDARD	24
8.4 TEST SETUP	24
8.5 EUT OPERATION CONDITIONS	24
8.6 TEST RESULTS	24
9 . MAXIMUM OUTPUT POWER	25
9.1 LIMIT	25
9.2 TEST PROCEDURE	25
9.3 DEVIATION FROM STANDARD	25
9.4 TEST SETUP	25
9.5 EUT OPERATION CONDITIONS	25
9.6 TEST RESULTS	25
10 . CONDUCTED SPURIOUS EMISSION	26
10.1 LIMIT	26
10.2 TEST PROCEDURE	26
10.3 DEVIATION FROM STANDARD	26
10.4 TEST SETUP	26
10.5 EUT OPERATION CONDITIONS	26

Table of Contents**Page**

10.6 TEST RESULTS	26
11 . MEASUREMENT INSTRUMENTS LIST	27
12 . EUT TEST PHOTO	28
APPENDIX A - AC POWER LINE CONDUCTED EMISSIONS	31
APPENDIX B - RADIATED EMISSION - 9 KHZ TO 30 MHZ	33
APPENDIX C - RADIATED EMISSION - 30 MHZ TO 1000 MHZ	34
APPENDIX D - RADIATED EMISSION - ABOVE 1000 MHZ	36
APPENDIX E - NUMBER OF HOPPING FREQUENCY	45
APPENDIX F - AVERAGE TIME OF OCCUPANCY	47
APPENDIX G - HOPPING CHANNEL SEPARATION	51
APPENDIX H - BANDWIDTH	53
APPENDIX I - MAXIMUM OUTPUT POWER	61
APPENDIX J - CONDUCTED SPURIOUS EMISSION	65
APPENDIX K - DECLARATION FOR BLUETOOTH DEVICE	72

REPORT ISSUED HISTORY

Report No.	Version	Description	Issued Date	Note
FCC022023-0289RF6	V1.0	Original Report.	2023.03.21	Valid

1. SUMMARY OF TEST RESULTS

Test procedures according to the technical standard(s):

FCC CFR Title 47, Part 15, Subpart C				
Standard(s) Section	Test Item	Test Result	Judgment	Remark
15.207	AC Power Line Conducted Emissions	APPENDIX A	PASS	-----
15.247(d) 15.205(a) 15.209(a)	Radiated Emission	APPENDIX B APPENDIX C APPENDIX D	PASS	-----
15.247 (a)(1)(iii)	Number of Hopping Frequency	APPENDIX E	PASS	-----
15.247 (a)(1)(iii)	Average Time of Occupancy	APPENDIX F	PASS	-----
15.247(a)(1)	Hopping Channel Separation	APPENDIX G	PASS	-----
15.247(a)(1)	Bandwidth	APPENDIX H	PASS	-----
15.247(a)(1)	Maximum Output Power	APPENDIX I	PASS	-----
15.247(d)	Conducted Spurious Emission	APPENDIX J	PASS	-----
15.203	Antenna Requirement	-----	PASS	Note(2)

Note:

- (1) "N/A" denotes test is not applicable in this test report
- (2) The device what use a permanently attached antenna were considered sufficient to comply with the provisions of 15.203.

1.1 TEST FACILITY

Company:	Beijing TIRT Technology Service Co.,Ltd Shenzhen
Address:	101, 3 # Factory Building, Gongjin Electronics Shatin Community, Kengzi Street, Pingshan District, Shenzhen, China
CNAS Registration Number:	CNAS L14158
A2LA Registration Number:	6049.01
FCC Accredited Lab. Designation Number:	CN1309
FCC Test Firm Registration Number:	825524
Telephone:	+86-0755-27087573

1.2 MEASUREMENT UNCERTAINTY

ISO/IEC 17025 requires that an estimate of the measurement uncertainties associated with the emissions test results be included in the report. The measurement uncertainties given below are based on a 95% confidence level (based on a coverage factor (k=2))

The BTL measurement uncertainty as below table:

Parameter	Uncertainty
Occupied Channel Bandwidth	±142.12 KHz
RF power conducted	±0.74 dB
RF power radiated	±3.25dB
Spurious emissions, conducted	±1.78dB
Spurious emissions, radiated (30MHz~1GHz)	±4.6dB
Spurious emissions, radiated (1GHz ~ 18GHz)	±4.9dB
Conduction Emissions(150kHz~30MHz)	±3.1 dB
Humidity	±4.6%
Temperature	±0.7°C
Time	±1.25%

Note: Unless specifically mentioned, the uncertainty of measurement has not been taken into account to declare the compliance or non-compliance to the specification.

1.3 TEST ENVIRONMENT CONDITIONS

Test Item	Temperature	Humidity	Test Voltage	Tested By
AC Power Line Conducted Emissions	25°C	53%	AC 120V/60Hz	Stone Tang
Radiated Emissions-9 kHz to 30 MHz	24°C	51%	AC 120V/60Hz	Stone Tang
Radiated Emissions-30 MHz to 1000 MHz	24°C	51%	AC 120V/60Hz	Stone Tang
Radiated Emissions-Above 1000 MHz	24°C	51%	AC 120V/60Hz	Stone Tang
Bandwidth	24.5°C	52%	AC 120V/60Hz	Stone Tang
Maximum Output Power	24.5°C	52%	AC 120V/60Hz	Stone Tang
Conducted Spurious Emission	24.5°C	52%	AC 120V/60Hz	Stone Tang
Power Spectral Density	24.5°C	52%	AC 120V/60Hz	Stone Tang

2. GENERAL INFORMATION

2.1 GENERAL DESCRIPTION OF EUT

Equipment	Computer
Brand Name	IPASON
Test Model	IPASONS6-X7004457152
Series Model	IPASONS6***** (* can be 0-9,a-z,A-Z or "-")
Model Difference(s)	Models differ only from sales customers, markets, etc. RF and electromagnetic compatibility are not affected.
Software Version	V1.0
Hardware Version	V1.0
Power Source	Voltage supplied from AC
Power Rating	AC 100-240V~50/60Hz 10-6A
Operation Frequency	2402 MHz ~ 2480 MHz
Modulation Type	GFSK, $\pi/4$ -DQPSK, 8-DPSK
Bit Rate of Transmitter	1Mbps, 2Mbps, 3Mbps
Max. Output Power	3Mbps: 10.38 dBm (0.0109W)

Note:

1. For a more detailed features description, please refer to the manufacturer's specifications or the user's manual.

2. Channel List:

Channel	Frequency (MHz)	Channel	Frequency (MHz)	Channel	Frequency (MHz)
00	2402	27	2429	54	2456
01	2403	28	2430	55	2457
02	2404	29	2431	56	2458
03	2405	30	2432	57	2459
04	2406	31	2433	58	2460
05	2407	32	2434	59	2461
06	2408	33	2435	60	2462
07	2409	34	2436	61	2463
08	2410	35	2437	62	2464
09	2411	36	2438	63	2465
10	2412	37	2439	64	2466
11	2413	38	2440	65	2467
12	2414	39	2441	66	2468
13	2415	40	2442	67	2469
14	2416	41	2443	68	2470
15	2417	42	2444	69	2471
16	2418	43	2445	70	2472
17	2419	44	2446	71	2473
18	2420	45	2447	72	2474
19	2421	46	2448	73	2475
20	2422	47	2449	74	2476
21	2423	48	2450	75	2477
22	2424	49	2451	76	2478
23	2425	50	2452	77	2479
24	2426	51	2453	78	2480
25	2427	52	2454		
26	2428	53	2455		

3. Table for Filed Antenna:

Ant.	Brand	Model Name	Antenna Type	Connector	Gain (dBi)
1	N/A	N/A	Dipole	N/A	4.69

Note:

1. The antenna gain is provided by the manufacturer.
2. The antenna is for testing purposes only.

2.2 DESCRIPTION OF TEST MODES

The test system was pre-tested based on the consideration of all possible combinations of EUT operation mode.

Pretest Mode	Description
Mode 1	TX Mode_1Mbps Channel 00/39/78
Mode 2	TX Mode_2Mbps Channel 00/39/78
Mode 3	TX Mode_3Mbps Channel 00/39/78

Following mode(s) was (were) found to be the worst case(s) and selected for the final test.

AC power line conducted emissions test	
Final Test Mode	Description
Mode 3	TX Mode_3Mbps Channel 00

Radiated emissions test - Below 1GHz	
Final Test Mode	Description
Mode 3	TX Mode_3Mbps Channel 00

Radiated emissions test - Above 1GHz	
Final Test Mode	Description
Mode 1	TX Mode_1Mbps Channel 00/39/78
Mode 3	TX Mode_3Mbps Channel 00/39/78

Maximum Output Power	
Final Test Mode	Description
Mode 1	TX Mode_1Mbps Channel 00/39/78
Mode 2	TX Mode_2Mbps Channel 00/39/78
Mode 3	TX Mode_3Mbps Channel 00/39/78

Other Conducted test	
Final Test Mode	Description
Mode 1	TX Mode_1Mbps Channel 00/39/78
Mode 3	TX Mode_3Mbps Channel 00/39/78

Note:

- (1) The measurements for Output Power were tested with DH1/3/5 during 1Mbps, 2Mbps and 3Mbps, the worst case were 1Mbps (DH5) and 3Mbps (DH5), only worst case were documented for other test items except Average Time of Occupancy.
- (2) For radiated emission above 1 GHz test, the spurious points of 1GHz~18GHz and 18GHz~26.5GHz have been pre-tested and in this report only recorded the worst case. The remaining spurious points are all below the limit value of 20dB.
- (3) This product has the mode of BT AFH, which was considered during testing. 800/20/X(X = 2 of DH1, X = 4 of DH3 or X = 6 of DH5) with 20, 10 or 6.67 hops per second in a channel, and then multiply 0.4*20 (20 # of hopping). But this mode is not the worst case mode as duration of the packet is same, and this report only shows the worst case mode.
- (4) For AC power line conducted emissions and radiated spurious emissions below 1 GHz test, the 1Mbps Channel 78 are found to be the worst case and recorded.

2.3 PARAMETERS OF TEST SOFTWARE

During testing, channel & power controlling software provided by the customer was used to control the operating channel as well as the output power level.

Test Software Version	AuthenticTool_1.2.14.0		
Frequency (MHz)	2402	2441	2480
1Mbps	default	default	default
2Mbps	default	default	default
3Mbps	default	default	default

2.4 BLOCK DIAGRAM SHOWING THE CONFIGURATION OF SYSTEM TESTED**2.5 SUPPORT UNITS**

Support Equipment				
No.	Equipment	Brand Name	Model Name	Remarks
1	N/A	N/A	N/A	N/A

3. AC POWER LINE CONDUCTED EMISSIONS

3.1 LIMIT

Frequency of Emission (MHz)	Limit (dB μ V)	
	Quasi-peak	Average
0.15 - 0.5	66 to 56*	56 to 46*
0.5 - 5.0	56	46
5.0 - 30.0	60	50

Note:

- (1) The tighter limit applies at the band edges.
- (2) The limit of " * " marked band means the limitation decreases linearly with the logarithm of the frequency in the range.

3.2 TEST PROCEDURE

- a. The EUT was placed 0.8 meters from the horizontal ground plane with EUT being connected to the power mains through a line impedance stabilization network (LISN). All other support equipment powered from additional LISN(s). The LISN provide 50 Ohm/ 50uH of coupling impedance for the measuring instrument.
- b. Interconnecting cables that hang closer than 40 cm to the ground plane shall be folded back and forth in the center forming a bundle 30 to 40 cm long.
- c. I/O cables that are not connected to a peripheral shall be bundled in the center. The end of the cable may be terminated, if required, using the correct terminating impedance. The overall length shall not exceed 1 m.
- d. LISN at least 80 cm from nearest part of EUT chassis.
- e. For the actual test configuration, please refer to the related Item –EUT Test Photos.

The following table is the setting of the receiver:

Receiver Parameters	Setting
Start Frequency	0.15 MHz
Stop Frequency	30 MHz
IF Bandwidth	9 kHz

3.3 DEVIATION FROM TEST STANDARD

No deviation.

3.4 TEST SETUP

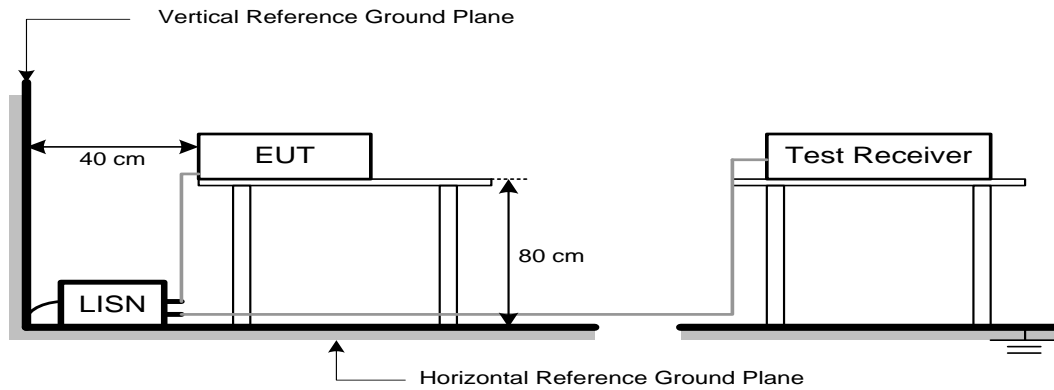

3.5 EUT OPERATING CONDITIONS

The EUT was configured for testing in a typical function (as a customer would normally use it), EUT was programmed to be in continuously transmitting data or hopping on mode.

3.6 TEST RESULTS

Please refer to the APPENDIX A.

Remark:

- (1) All readings are QP Mode value unless otherwise stated AVG in column of [Note] . If the QP Mode Measured value compliance with the QP Limits and lower than AVG Limits, the EUT shall be deemed to meet both QP & AVG Limits and then only QP Mode was measured, but AVG Mode didn't perform in this case, a "*" marked in AVG Mode column of Interference Voltage Measured.
- (2) Measuring frequency range from 150 kHz to 30 MHz.

4. RADIATED EMISSIONS

4.1 LIMIT

In case the emission fall within the restricted band specified on 15.205(a), then the 15.209(a) limit in the table below has to be followed.

LIMITS OF RADIATED EMISSION MEASUREMENT (9 kHz-1000 MHz)

Frequency (MHz)	Field Strength (microvolts/meter)	Measurement Distance (meters)
0.009-0.490	2400/F(kHz)	300
0.490-1.705	24000/F(kHz)	30
1.705-30.0	30	30
30-88	100	3
88-216	150	3
216-960	200	3
Above 960	500	3

LIMITS OF RADIATED EMISSION MEASUREMENT (Above 1000 MHz)

Frequency (MHz)	(dBuV/m at 3 m)	
	Peak	Average
Above 1000	74	54

Note:

- (1) The limit for radiated test was performed according to FCC CFR Title 47, Part 15, Subpart C.
- (2) The tighter limit applies at the band edges.
- (3) Emission level (dBuV/m)=20log Emission level (uV/m).

4.2 TEST PROCEDURE

- a. The measuring distance of 3 m shall be used for measurements. The EUT was placed on the top of a rotating table 0.8 meter above the ground at a 3 meter semi-anechoic chamber. The table was rotated 360 degrees to determine the position of the highest radiation.(below 1 GHz)
- b. The measuring distance of 3 m shall be used for measurements. The EUT was placed on the top of a rotating table 1.5 meter above the ground at a 3 meter semi-anechoic chamber. The table was rotated 360 degrees to determine the position of the highest radiation.(above 1 GHz)
- c. The height of the equipment or of the substitution antenna shall be 0.8m or 1.5m; the height of the test antenna shall vary between 1 m to 4 m. Both horizontal and vertical polarizations of the antenna are set to make the measurement.
- d. For each suspected emission, the EUT was arranged to its worst case and then the antenna was tuned to heights find the maximum reading (used Bore sight function).
- e. The receiver system was set to peak and average detect function and specified bandwidth with maximum hold mode when the test frequency is above 1 GHz.
- f. The initial step in collecting radiated emission data is a receiver peak detector mode pre-scanning the measurement frequency range. Significant peaks are then marked and then Quasi Peak detector mode re-measured.
- g. All readings are Peak unless otherwise stated QP in column of Note. Peak denotes that the Peak reading compliance with the QP Limits and then QP Mode measurement didn't perform.
(below 1 GHz)
- h. All readings are Peak Mode value unless otherwise stated AVG in column of Note. If the Peak Mode Measured value compliance with the Peak Limits and lower than AVG Limits, the EUT shall be deemed to meet both Peak & AVG Limits and then only Peak Mode was measured, but AVG Mode didn't perform. (above 1 GHz)
- i. For the actual test configuration, please refer to the related Item –EUT Test Photos.

The following table is the setting of the receiver:

Spectrum Parameters	Setting
Start ~ Stop Frequency	9 kHz~150 kHz for RBW 200 Hz
Start ~ Stop Frequency	0.15 MHz~30 MHz for RBW 9 kHz
Start ~ Stop Frequency	30 MHz~1000 MHz for RBW 100 kHz

Spectrum Parameters	Setting
Start Frequency	1000 MHz
Stop Frequency	10th carrier harmonic
RBW / VBW (Emission in restricted band)	1 MHz / 3 MHz for PK value 1 MHz / 1/T Hz for AVG value

Spectrum Parameters	Setting
Start ~ Stop Frequency	9 kHz~90 kHz for PK/AVG detector
Start ~ Stop Frequency	90 kHz~110 kHz for QP detector
Start ~ Stop Frequency	110 kHz~490 kHz for PK/AVG detector
Start ~ Stop Frequency	490 kHz~30 MHz for QP detector
Start ~ Stop Frequency	30 MHz~1000 MHz for QP detector
Start ~ Stop Frequency	1 GHz~26.5 GHz for PK/AVG detector

4.3 DEVIATION FROM TEST STANDARD

No deviation.

4.4 TEST SETUP

9 kHz to 30 MHz

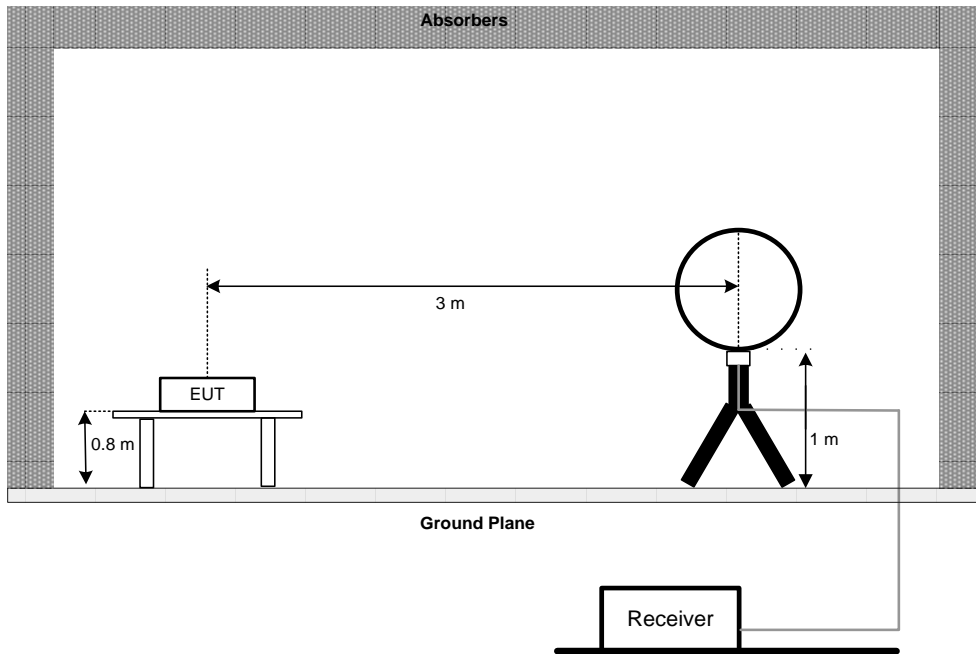

30 MHz to 1 GHz

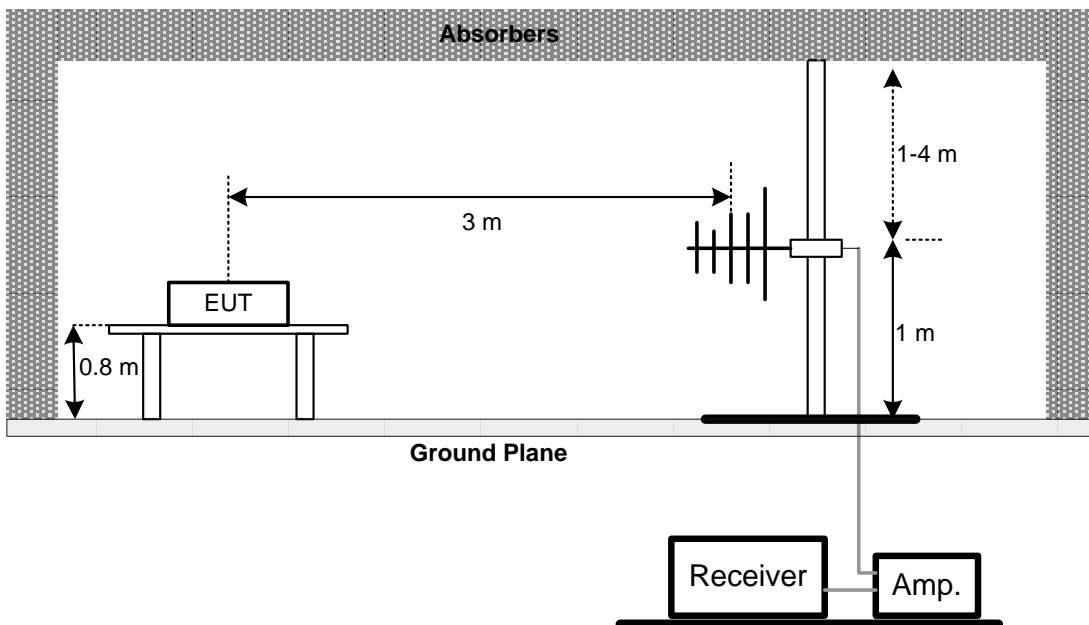

Above 1 GHz

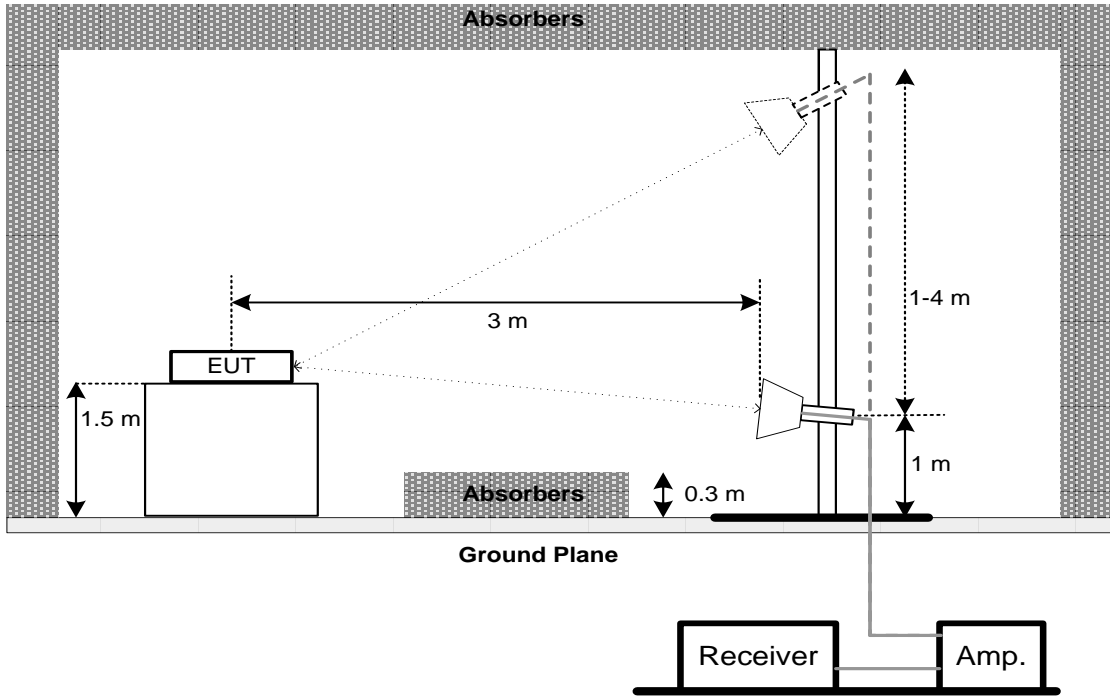

4.5 EUT OPERATING CONDITIONS

The EUT was programmed to be in continuously transmitting mode.

4.6 TEST RESULTS - 9 kHz TO 30 MHz

Please refer to the APPENDIX B.

Remark:

- (1) Distance extrapolation factor = $40 \log(\text{specific distance} / \text{test distance})$ (dB).
- (2) Limit line = specific limits (dBuV) + distance extrapolation factor.

4.7 TEST RESULTS - 30 MHz TO 1000 MHz

Please refer to the APPENDIX C.

4.8 TEST RESULTS - ABOVE 1000 MHz

Please refer to the APPENDIX D.

Remark:

- (1) No limit: This is fundamental signal, the judgment is not applicable.
For fundamental signal judgment was referred to Peak output test.

5. NUMBER OF HOPPING FREQUENCY

5.1 LIMIT

Section	Test Item	Limit
FCC 15.247(a)(1)(iii)	Number of Hopping Frequency	15

5.2 TEST PROCEDURE

- The EUT was directly connected to the tonscend test system and antenna output port as show in the block diagram below.
- The following table is the setting of the spectrum analyzer:

Spectrum Parameters	Setting
Span Frequency	> Operating Frequency Range
RBW	100 kHz
VBW	100 kHz
Detector	Peak
Trace	Max Hold
Sweep Time	Auto

5.3 DEVIATION FROM STANDARD

No deviation.

5.4 TEST SETUP

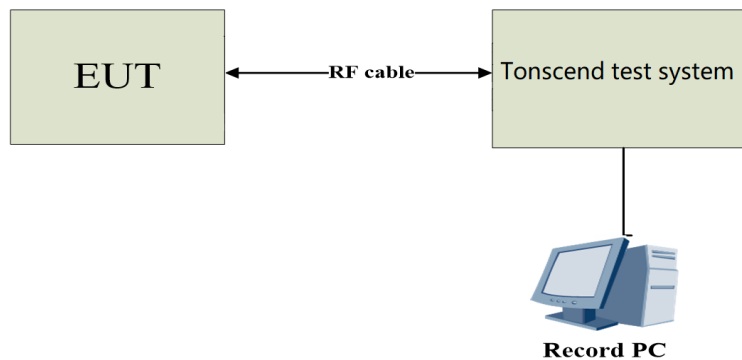

5.5 EUT OPERATION CONDITIONS

The EUT was programmed to be in continuously transmitting mode.

5.6 TEST RESULTS

Please refer to the APPENDIX E.

6. AVERAGE TIME OF OCCUPANCY

6.1 LIMIT

Section	Test Item	Limit
FCC 15.247(a)(1)(iii)	Average Time of Occupancy	0.4sec

6.2 TEST PROCEDURE

- Set the EUT for DH1, DH3 and DH5 packet transmitting.
- Measure the maximum time duration of one single pulse.
- DH1 Packet permit maximum $1600 / 79 / 2 = 10.12$ hops per second in each channel (1 time slot TX, 1 time slot RX). So, the dwell time is the time duration of the pulse times $10.12 \times 31.6 = 320$ within 31.6 seconds.
- DH3 Packet permit maximum $1600 / 79 / 4 = 5.06$ hops per second in each channel (3 time slots TX, 1 time slot RX). So, the dwell time is the time duration of the pulse times $5.06 \times 31.6 = 160$ within 31.6 seconds.
- DH5 Packet permit maximum $1600 / 79 / 6 = 3.37$ hops per second in each channel (5 time slots TX, 1 time slot RX). So, the dwell time is the time duration of the pulse times $3.37 \times 31.6 = 106.6$ within 31.6 seconds.
- The EUT was directly connected to the tonscend test system and antenna output port as show in the block diagram below.
- The following table is the setting of the spectrum analyzer:

Spectrum Parameters	Setting
Span Frequency	0 MHz
RBW	1 MHz
VBW	1 MHz
Detector	Peak
Trace	Max Hold
Sweep Time	As necessary to capture the entire dwell time per hopping channel

6.3 DEVIATION FROM STANDARD

No deviation.

6.4 TEST SETUP

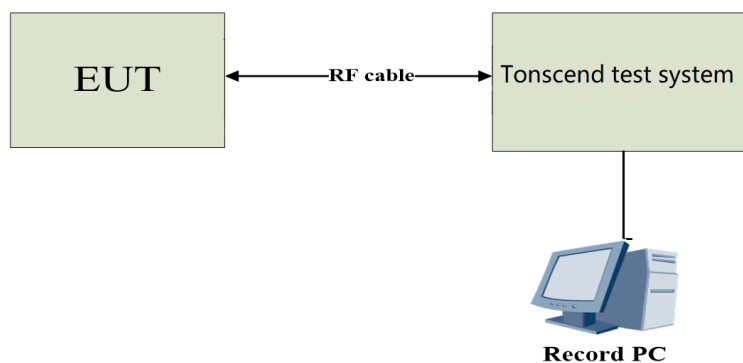

6.5 EUT OPERATION CONDITIONS

The EUT was programmed to be in continuously transmitting mode.

6.6 TEST RESULTS

Please refer to the APPENDIX F.

7. HOPPING CHANNEL SEPARATION

7.1 LIMIT

Frequency hopping systems operating in the 2400-2483.5 MHz band may have hopping channel carrier frequencies that are separated by 25 kHz or two-thirds of the 20 dB bandwidth of the hopping channel, whichever is greater, provided the systems operate with an output power no greater than 125 mW.

7.2 TEST PROCEDURE

- The EUT was directly connected to the tonscond test system and antenna output port as show in the block diagram below.
- The following table is the setting of the spectrum analyzer:

Spectrum Parameters	Setting
Span Frequency	Wide enough to capture the peaks of two adjacent channels
RBW	30 kHz
VBW	100 kHz
Detector	Peak
Trace	Max Hold
Sweep Time	Auto

7.3 DEVIATION FROM STANDARD

No deviation.

7.4 TEST SETUP

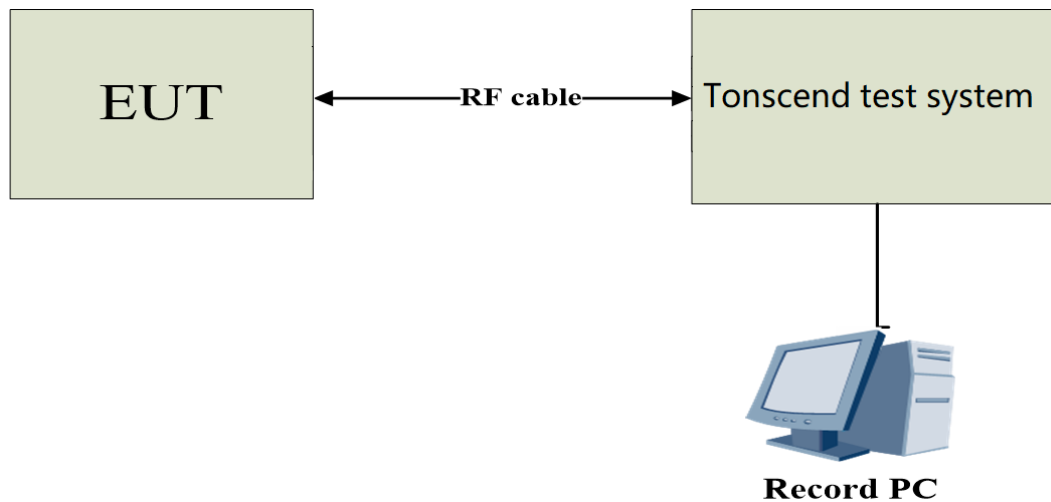

7.5 EUT OPERATION CONDITIONS

The EUT was programmed to be in continuously transmitting mode.

7.6 TEST RESULTS

Please refer to the APPENDIX G.

8. BANDWIDTH

8.1 LIMIT

Section	Test Item
FCC 15.247(a)(1)	Bandwidth

8.2 TEST PROCEDURE

- The EUT was directly connected to the tonscend test system and antenna output port as show in the block diagram below.
- The following table is the setting of the spectrum analyzer:

Spectrum Parameters	Setting
Span Frequency	> Measurement Bandwidth
RBW	30 kHz
VBW	100 kHz
Detector	Peak
Trace	Max Hold
Sweep Time	Auto

8.3 DEVIATION FROM STANDARD

No deviation.

8.4 TEST SETUP

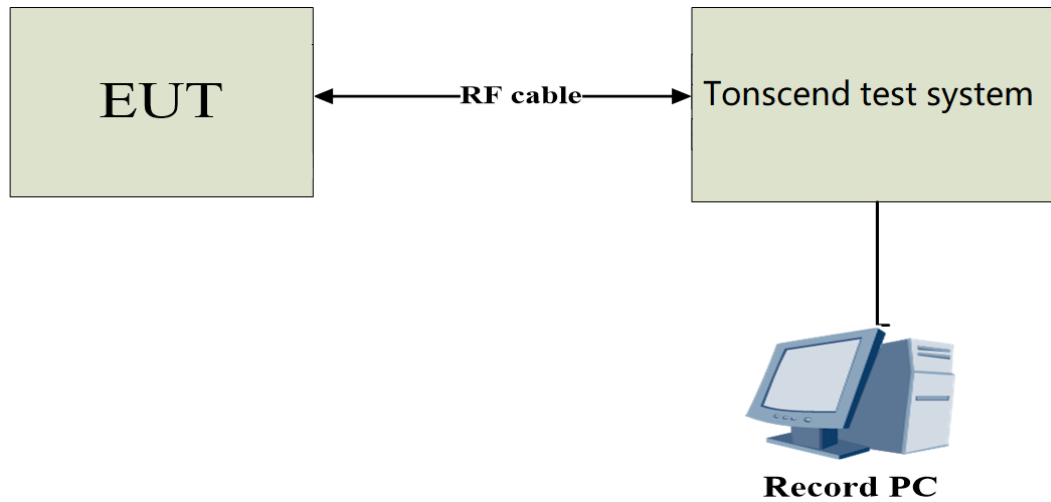

8.5 EUT OPERATION CONDITIONS

The EUT was programmed to be in continuously transmitting mode.

8.6 TEST RESULTS

Please refer to the APPENDIX H.

9. MAXIMUM OUTPUT POWER

9.1 LIMIT

Section	Test Item	Limit
FCC 15.247(a)(1)	Maximum Output Power	0.1250 Watt or 20.97 dBm

Note: Frequency hopping systems operating in the 2400-2483.5 MHz band may have hopping channel carrier frequencies that are separated by 25 kHz or two-thirds of the 20 dB bandwidth of the hopping channel, whichever is greater, provided the systems operate with an output power no greater than 125 mW.

9.2 TEST PROCEDURE

- The EUT was directly connected to the tonscend test system and antenna output port as show in the block diagram below.
- The following table is the setting of the spectrum analyzer:

Spectrum Parameters	Setting
Span Frequency	Approximately five times the 20 dB bandwidth, centered on a hopping channel.
RBW	3 MHz
VBW	3 MHz
Detector	Peak
Trace	Max Hold
Sweep Time	Auto

9.3 DEVIATION FROM STANDARD

No deviation.

9.4 TEST SETUP

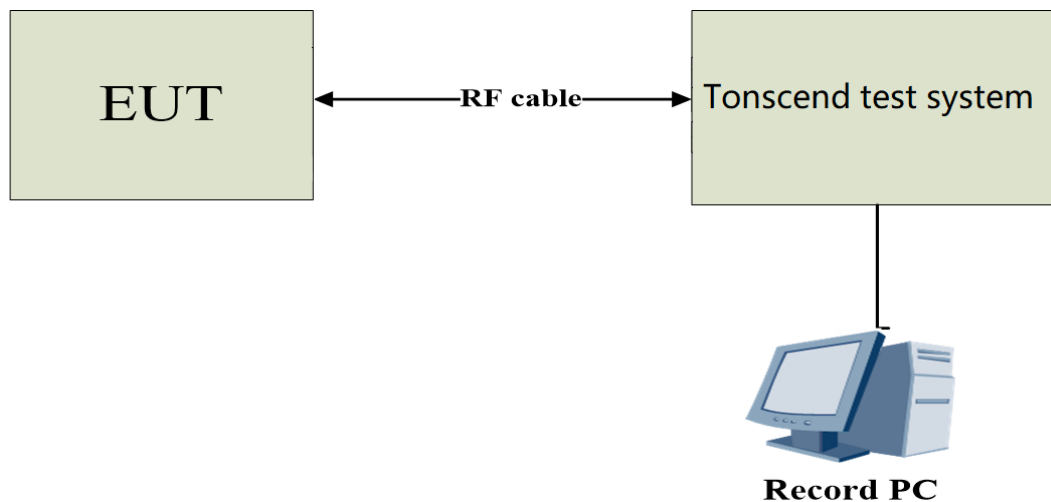

9.5 EUT OPERATION CONDITIONS

The EUT was programmed to be in continuously transmitting mode.

9.6 TEST RESULTS

Please refer to the APPENDIX I.

10. CONDUCTED SPURIOUS EMISSION

10.1 LIMIT

In any 100 kHz bandwidth outside the frequency band in which the spread spectrum or digitally modulated intentional radiator is operating, the radio frequency power that is produced by the intentional radiator shall be at least 20 dB below that in the 100 kHz bandwidth within the band that contains the highest level of the desired power, based on either an RF conducted or a radiated measurement, provided the transmitter demonstrates compliance with the peak Output Power limits. If the transmitter complies with the Output Power limits based on the use of RMS averaging over a time interval, as permitted under paragraph (b)(3) of this section, the attenuation required under this paragraph shall be 30 dB instead of 20 dB. Attenuation below the general limits specified in Section 15.209(a) is not required.

10.2 TEST PROCEDURE

- a. The EUT was directly connected to the tonscend test system and antenna output port as show in the block diagram below.
- b. The following table is the setting of the spectrum analyzer:

Spectrum Parameters	Setting
Start Frequency	30 MHz
Stop Frequency	26.5 GHz
RBW	100 kHz
VBW	100 kHz
Detector	Peak
Trace	Max Hold
Sweep Time	Auto

10.3 DEVIATION FROM STANDARD

No deviation.

10.4 TEST SETUP

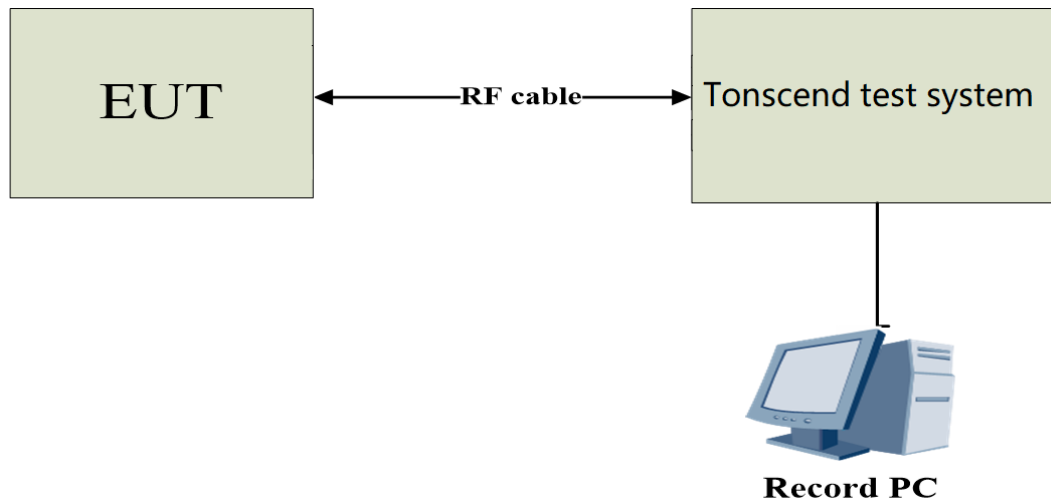

10.5 EUT OPERATION CONDITIONS

The EUT was programmed to be in continuously transmitting mode.

10.6 TEST RESULTS

Please refer to the APPENDIX J.

11. MEASUREMENT INSTRUMENTS LIST

No.	Equipment	Manufacturer	Type No.	Serial No.	Calibrated until
1	EMI Receiver	Rohde&Schwarz	ESCI	1166.5950.03	2023/10/14
2	AMN	Rohde&Schwarz	ENV216	3560.6550.05	2023/10/14
3	AMN	Schwarzbeck	NSLK8127	#829	2023/10/14
4	ECSI RF IN RF Cable	Rohde&Schwarz	RP-X1	\	2023/10/14
5	ECSI RF IN RF Cable	Rohde&Schwarz	Sapre sm	\	2023/10/14
6	EMI Receiver	Rohde&Schwarz	ESR7	102013	2023/10/14
7	Spectrum analyzer	Rohde&Schwarz	FSV30	103741	2023/10/17
8	EMI receiver	Rohde&Schwarz	ESU	100184	2023/07/20
9	Spectrum analyzer	KEYSIGHT	N9010A-44	MY51440158	2023/10/17
10	Loop Antenna*	Schwarzbeck	FMZB1519B	00029	2025/07/03
11	Integral Antenna	Schwarzbeck	VULB 9163	VULB 9163-361	2023/10/20
12	Integral Antenna	Schwarzbeck	BBHA 9120D	BBHA 9120D 1201	2023/10/15
13	Integral Antenna	Schwarzbeck	BBHA 9170	9170#685	2023/10/15
14	Preamplifier	CD Systems Inc	PAP-03036-30	85060000	2023/10/15
15	Preamplifier	Schwarzbeck	BBV9721	9721-019	2023/10/15
16	Preamplifier	emci	EMC012645 SE	980417	2023/10/16
17	ECSI RF IN RF Cable	Rohde&Schwarz	AP-X1	\	2023/10/16
18	Spectrum Analyzer	Agilent	N9010A	MY52221119	2023/10/17
19	Power Collection Unit	Tonscend	JS0806-2	188060134	2023/10/16
20	Tonscend Test System	Tonscend	2.6.77.0518	NA	NA
21	10dB Attenuator	Tonscend	10dB	NA	NA
22	Temp&Humidity Recorder	Anymetre	JR900	NA	2023/10/16
23	Temp&Humidity Chamber	ETOMA	NTH1100-30 A	16080628	2023/10/16
24	Filter	STI	STI15-9845	N/A	N/A
25	Filter	STI	5.1G	N/A	N/A
26	Filter	STI	STI15-9845	N/A	N/A
27	Testing Software	EZ-EMC	TW-03A2	N/A	N/A

Remark: "N/A" denotes no model name, serial no. or calibration specified.

"*" calibration period of equipment list is three year.

Except * item, all calibration period of equipment list is one year.

12. EUT TEST PHOTO

AC Power Line Conducted Emissions Test Photos



Radiated Emissions Test Photos

30 MHz to 1000 MHz



Radiated Emissions Test Photos

Above 1 GHz



Conducted Test Photos



APPENDIX A - AC POWER LINE CONDUCTED EMISSIONS

Test Mode	TX Mode_3Mbps Channel 00	Phase	Line
-----------	--------------------------	-------	------

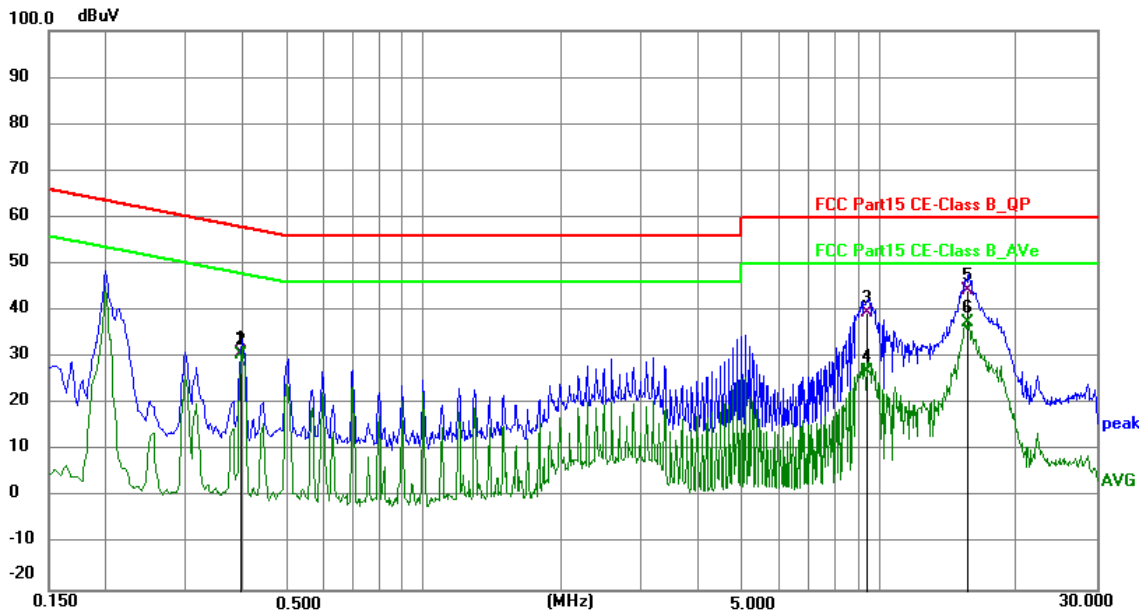

No.	Frequency (MHz)	Reading (dBuV)	Factor (dB)	Level (dBuV)	Limit (dBuV)	Margin (dB)	Detector	P/F
1	0.3972	21.30	9.63	30.93	57.91	-26.98	QP	P
2	0.3972	21.01	9.63	30.64	47.91	-17.27	AVG	P
3	9.4518	29.73	9.72	39.45	60.00	-20.55	QP	P
4	9.4518	17.38	9.72	27.10	50.00	-22.90	AVG	P
5	15.7330	34.72	9.75	44.47	60.00	-15.53	QP	P
6 *	15.7330	27.68	9.75	37.43	50.00	-12.57	AVG	P

REMARKS:

- (1) Measurement Value = Reading Level + Correct Factor.
- (2) Margin Level = Measurement Value - Limit Value.

Test Mode	TX Mode_3Mbps Channel 00	Phase	Neutral
-----------	--------------------------	-------	---------

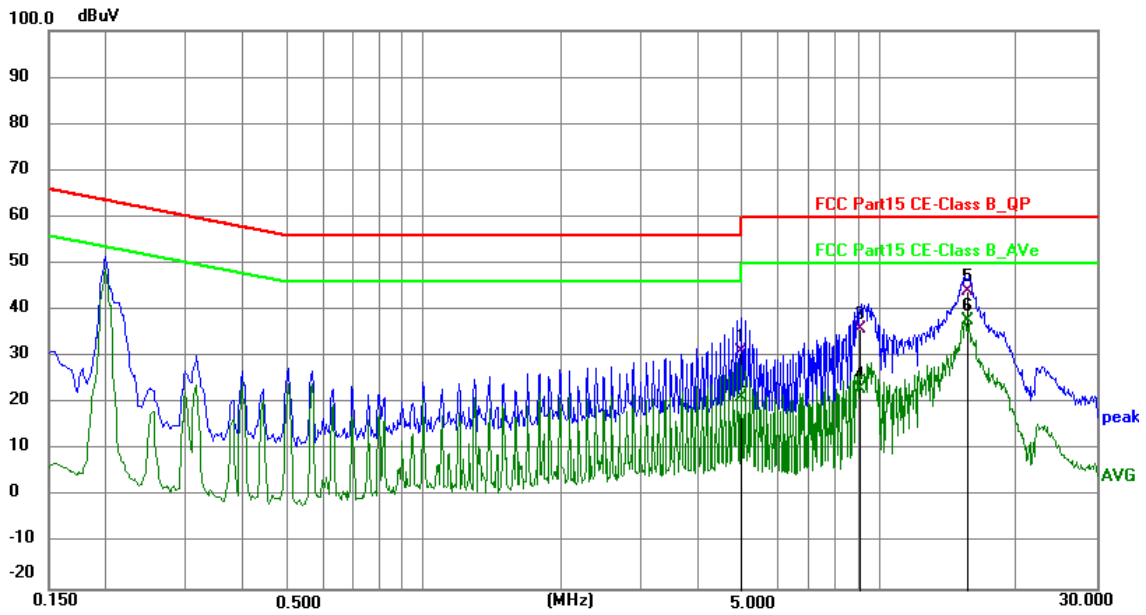

No.	Frequency (MHz)	Reading (dBuV)	Factor (dB)	Level (dBuV)	Limit (dBuV)	Margin (dB)	Detector	P/F
1	4.9809	21.57	9.68	31.25	56.00	-24.75	QP	P
2	4.9809	11.65	9.68	21.33	46.00	-24.67	AVG	P
3	9.1462	26.37	9.72	36.09	60.00	-23.91	QP	P
4	9.1462	13.21	9.72	22.93	50.00	-27.07	AVG	P
5	15.7260	34.25	9.77	44.02	60.00	-15.98	QP	P
6 *	15.7260	28.09	9.77	37.86	50.00	-12.14	AVG	P

REMARKS:

- (1) Measurement Value = Reading Level + Correct Factor.
- (2) Margin Level = Measurement Value - Limit Value.

APPENDIX B - RADIATED EMISSION - 9 KHZ TO 30 MHZ

The low frequency, which started from 9 kHz to 30MHz, was pre-scanned and the result which was 20dB lower than the limit line was not reported.

There is a comparison data of both open-field test site and semi-Anechoic chamber, and the result came out very similar.

APPENDIX C - RADIATED EMISSION - 30 MHZ TO 1000 MHZ

Test Mode	TX Mode_3Mbps Channel 00	Polarization	Vertical
-----------	--------------------------	--------------	----------

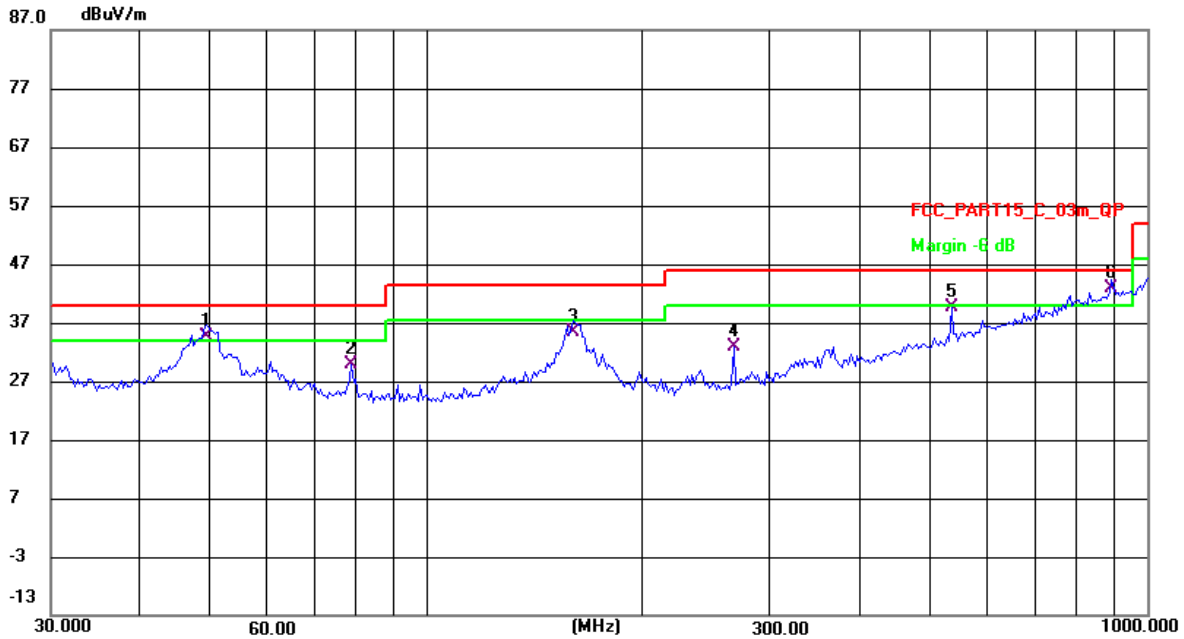

No.	Frequency (MHz)	Reading (dBuV)	Factor (dB/m)	Level (dBuV/m)	Limit (dBuV/m)	Margin (dB)	Detector	Height (cm)	Azimuth (deg.)	P/F
1 !	49.4087	21.30	13.31	34.61	40.00	-5.39	QP	100	158	P
2	78.5644	20.75	9.24	29.99	40.00	-10.01	QP	100	160	P
3	159.7586	21.90	13.38	35.28	43.50	-8.22	QP	100	130	P
4	266.8394	20.67	12.21	32.88	46.00	-13.12	QP	100	188	P
5	535.0375	20.83	18.77	39.60	46.00	-6.40	QP	100	270	P
6 *	893.6557	18.27	24.59	42.86	46.00	-3.14	QP	100	116	P

REMARKS:

- (1) Measurement Value = Reading Level + Correct Factor.
- (2) Margin Level = Measurement Value - Limit Value.

Test Mode	TX Mode_3Mbps Channel 00	Polarization	Horizontal
-----------	--------------------------	--------------	------------

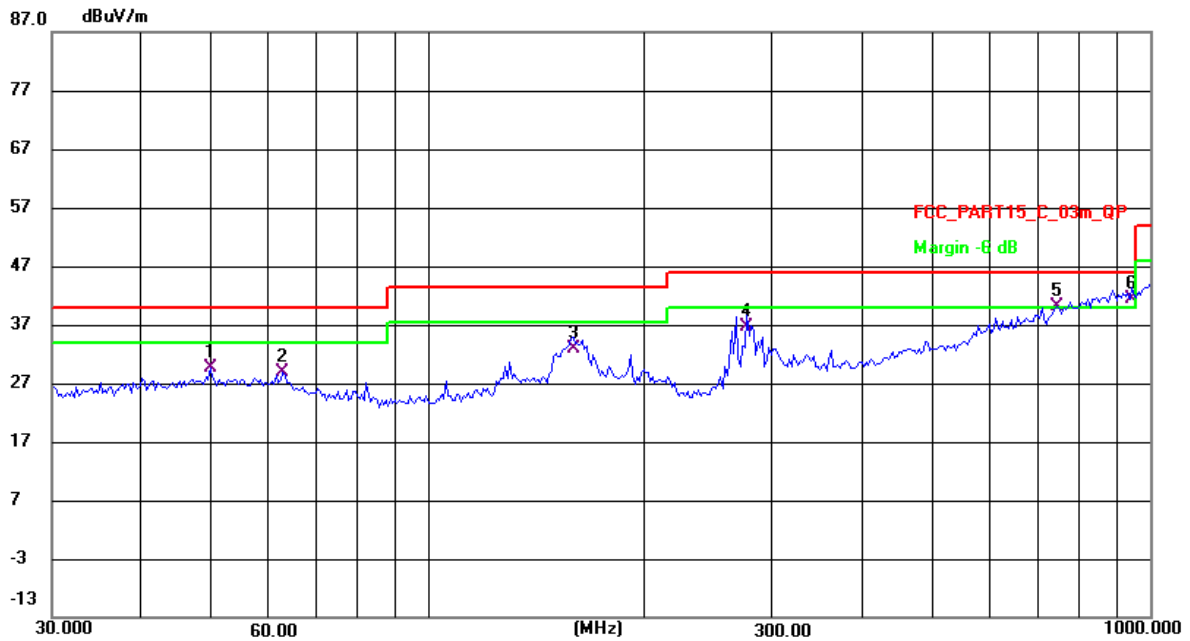

No.	Frequency (MHz)	Reading (dBuV)	Factor (dB/m)	Level (dBuV/m)	Limit (dBuV/m)	Margin (dB)	Detector	Height (cm)	Azimuth (deg.)	P/F
1	49.7571	16.24	13.32	29.56	40.00	-10.44	QP	100	68	P
2	62.7432	16.79	12.18	28.97	40.00	-11.03	QP	100	90	P
3	158.6399	19.42	13.39	32.81	43.50	-10.69	QP	100	100	P
4	276.3818	24.14	12.58	36.72	46.00	-9.28	QP	100	36	P
5 !	744.4265	17.06	22.96	40.02	46.00	-5.98	QP	100	180	P
6 *	945.3336	16.64	24.73	41.37	46.00	-4.63	QP	100	27	P

REMARKS:

- (1) Measurement Value = Reading Level + Correct Factor.
- (2) Margin Level = Measurement Value - Limit Value.

APPENDIX D - RADIATED EMISSION - ABOVE 1000 MHZ

Test Result of Radiated Spurious at Band edges

Test Mode	TX 2402 MHz _CH00_1Mbps	Polarization	Vertical
-----------	-------------------------	--------------	----------

Radiated Emission

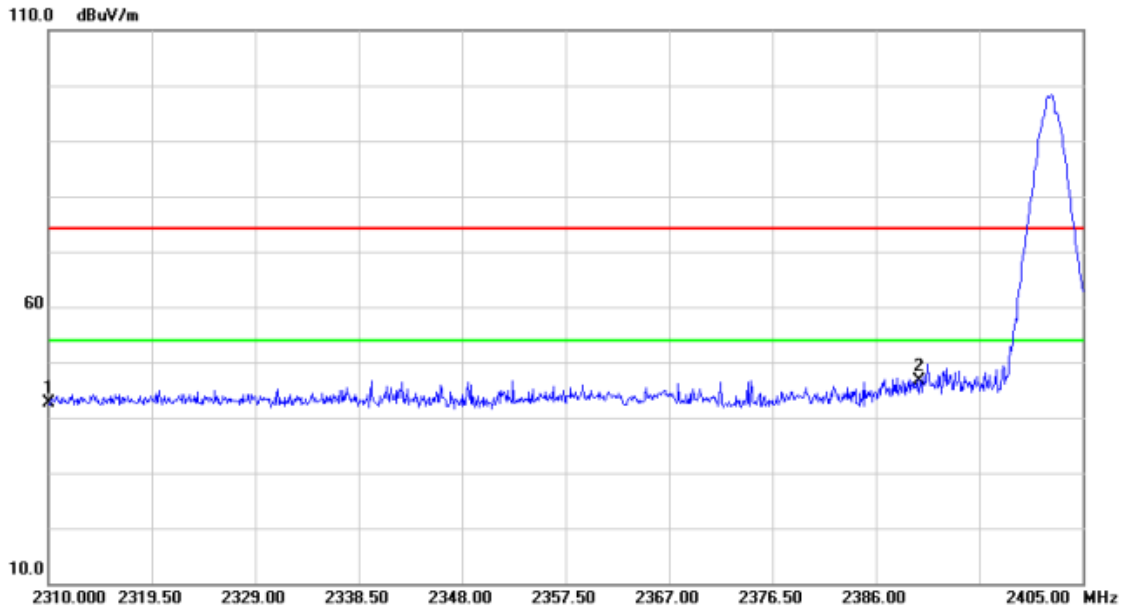

No.	Mk.	Freq.	Reading Level	Correct Factor	Measurement	Limit	Over	Antenna Height	Table Degree	
		MHz	dBuV	dB/m	dBuV/m	dBuV/m	dB	cm	degree	Comment
1		2310.000	54.47	-11.92	42.55	74.00	-31.45			peak
2	*	2390.000	58.19	-11.67	46.52	74.00	-27.48			peak

REMARKS:

- (1) Measurement Value = Reading Level + Correct Factor.
- (2) Margin Level = Measurement Value - Limit Value.

Test Result of Radiated Spurious at Band edges

Test Mode	TX 2402 MHz _CH00_1Mbps	Polarization	Horizontal
-----------	-------------------------	--------------	------------

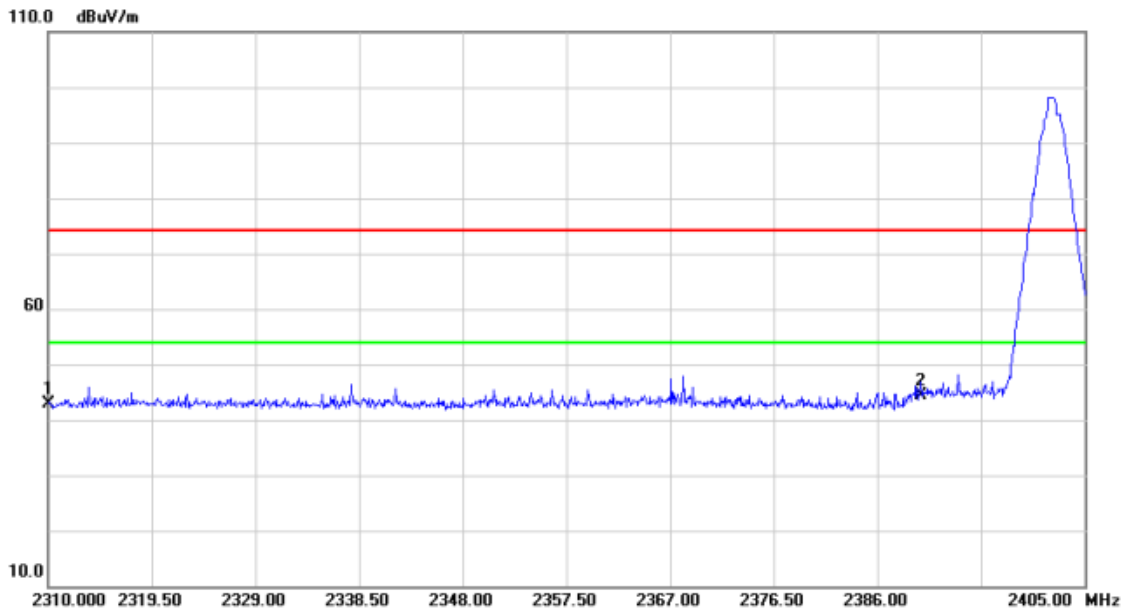
Radiated Emission

No.	Mk.	Freq.	Reading Level	Correct Factor	Measurement	Limit	Over	Antenna Height	Table Degree	
		MHz	dBuV	dB/m	dBuV/m	dBuV/m	dB	cm	degree	Comment
1		2310.000	54.84	-11.92	42.92	74.00	-31.08	peak		
2	*	2390.000	56.09	-11.67	44.42	74.00	-29.58	peak		

REMARKS:

- (1) Measurement Value = Reading Level + Correct Factor.
 (2) Margin Level = Measurement Value - Limit Value.

Test Result of Radiated Spurious at Band edges

Test Mode	TX 2480 MHz _CH78_1Mbps	Polarization	Vertical
-----------	-------------------------	--------------	----------

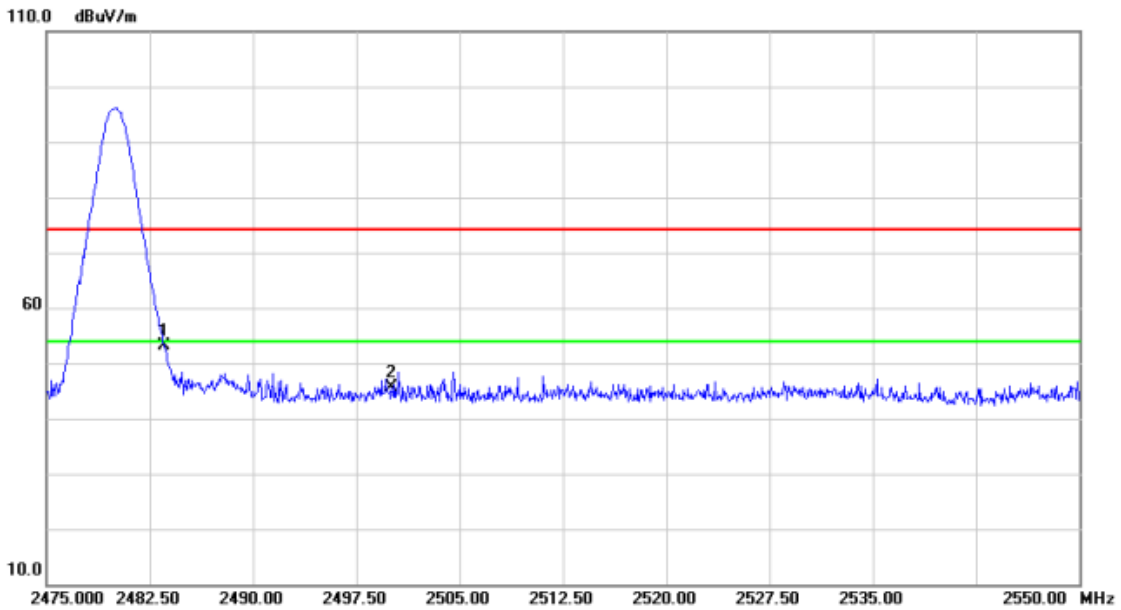
Radiated Emission

No.	Mk.	Freq.	Reading Level	Correct Factor	Measurement	Limit	Over	Antenna Height	Table Degree	
		MHz	dBuV	dB/m	dBuV/m	dBuV/m	dB	cm	degree	Comment
1	*	2483.500	64.41	-11.28	53.13	74.00	-20.87			peak
2		2500.000	56.87	-11.21	45.66	74.00	-28.34			peak

REMARKS:

- (1) Measurement Value = Reading Level + Correct Factor.
 (2) Margin Level = Measurement Value - Limit Value.

Test Result of Radiated Spurious at Band edges

Test Mode	TX 2480 MHz _CH78_1Mbps	Polarization	Horizontal
-----------	-------------------------	--------------	------------

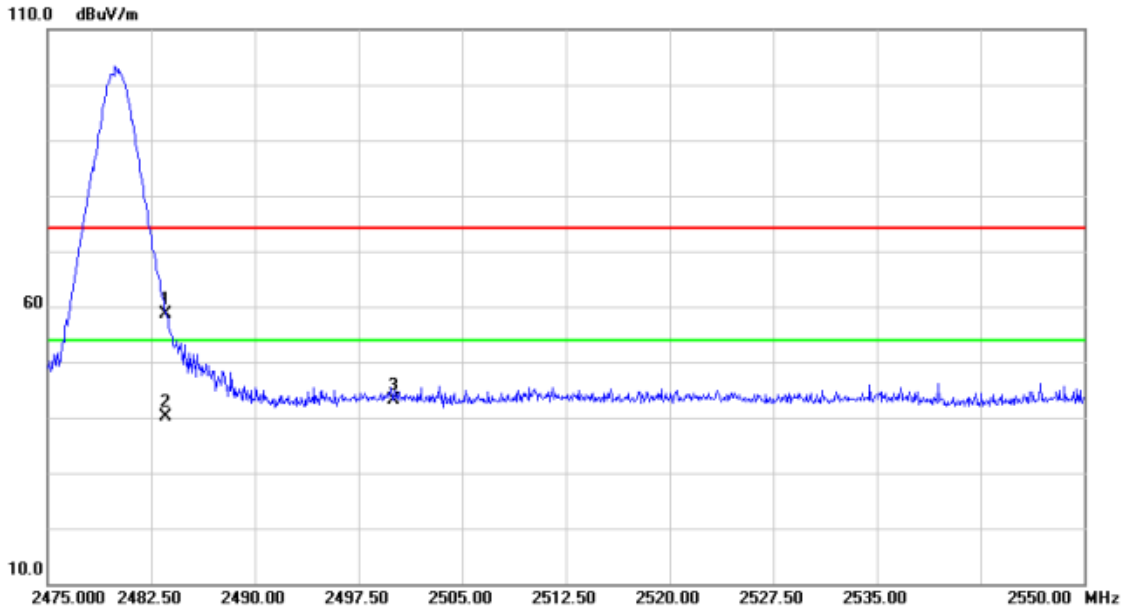
Radiated Emission

No.	Mk.	Freq.	Reading Level	Correct Factor	Measurement	Limit	Over	Antenna Height	Table Degree	
		MHz	dBuV	dB/m	dBuV/m	dBuV/m	dB	cm	degree	Comment
1		2483.500	69.85	-11.28	58.57	74.00	-15.43			peak
2	*	2483.500	51.41	-11.28	40.13	54.00	-13.87			AVG
3		2500.000	54.29	-11.21	43.08	74.00	-30.92			peak

REMARKS:

- (1) Measurement Value = Reading Level + Correct Factor.
 (2) Margin Level = Measurement Value - Limit Value.

Test Result of Radiated Spurious at Band edges

Test Mode	TX 2402 MHz _CH00_3Mbps	Polarization	Vertical
-----------	-------------------------	--------------	----------

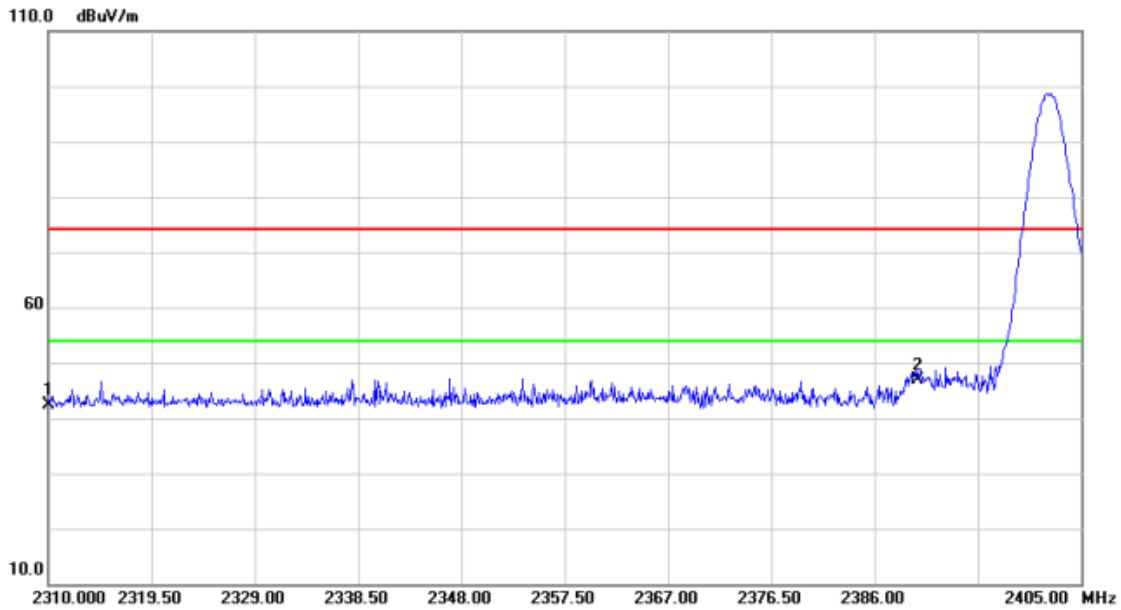
Radiated Emission

No.	Mk.	Freq.	Reading Level	Correct Factor	Measurement	Limit	Over	Antenna Height	Table Degree	
		MHz	dBuV	dB/m	dBuV/m	dBuV/m	dB	cm	degree	Comment
1		2310.000	54.39	-11.92	42.47	74.00	-31.53	peak		
2	*	2390.000	58.55	-11.67	46.88	74.00	-27.12	peak		

REMARKS:

- (1) Measurement Value = Reading Level + Correct Factor.
 (2) Margin Level = Measurement Value - Limit Value.

Test Result of Radiated Spurious at Band edges

Test Mode	TX 2402 MHz _CH00_3Mbps	Polarization	Horizontal
-----------	-------------------------	--------------	------------

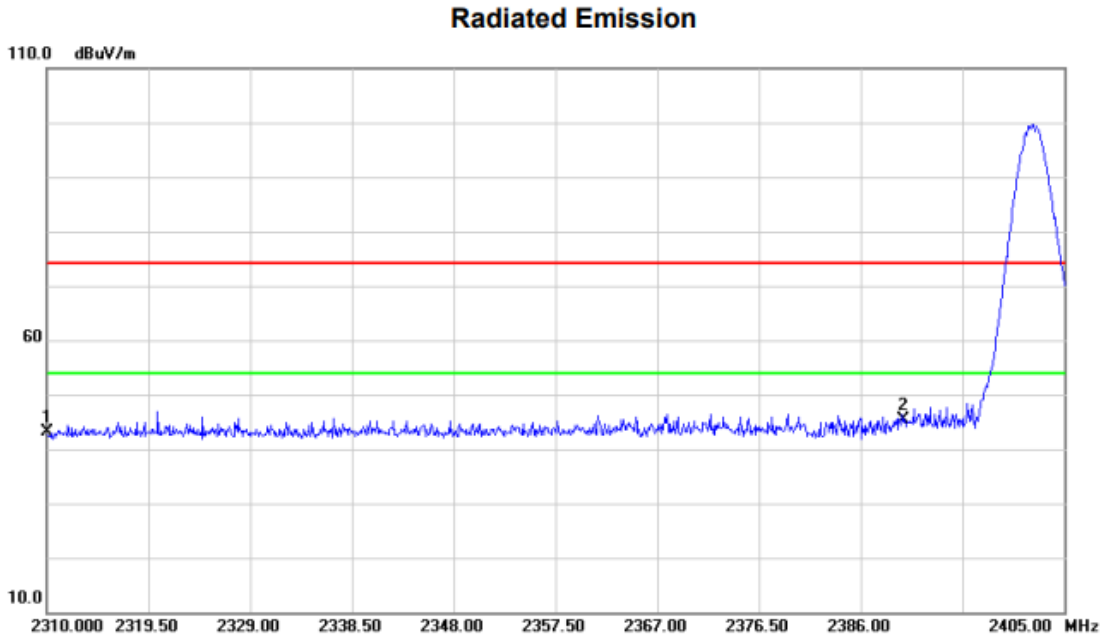

No.	Mk.	Freq.	Reading Level	Correct Factor	Measurement	Limit	Over	Antenna Height	Table Degree	
		MHz	dBuV	dB/m	dBuV/m	dBuV/m	dB	cm	degree	Comment
1		2310.000	55.08	-11.92	43.16	74.00	-30.84			peak
2 *		2390.000	57.15	-11.67	45.48	74.00	-28.52			peak

REMARKS:

- (1) Measurement Value = Reading Level + Correct Factor.
- (2) Margin Level = Measurement Value - Limit Value.

Test Result of Radiated Spurious at Band edges

Test Mode	TX 2480 MHz _CH78_3Mbps	Polarization	Vertical
-----------	-------------------------	--------------	----------

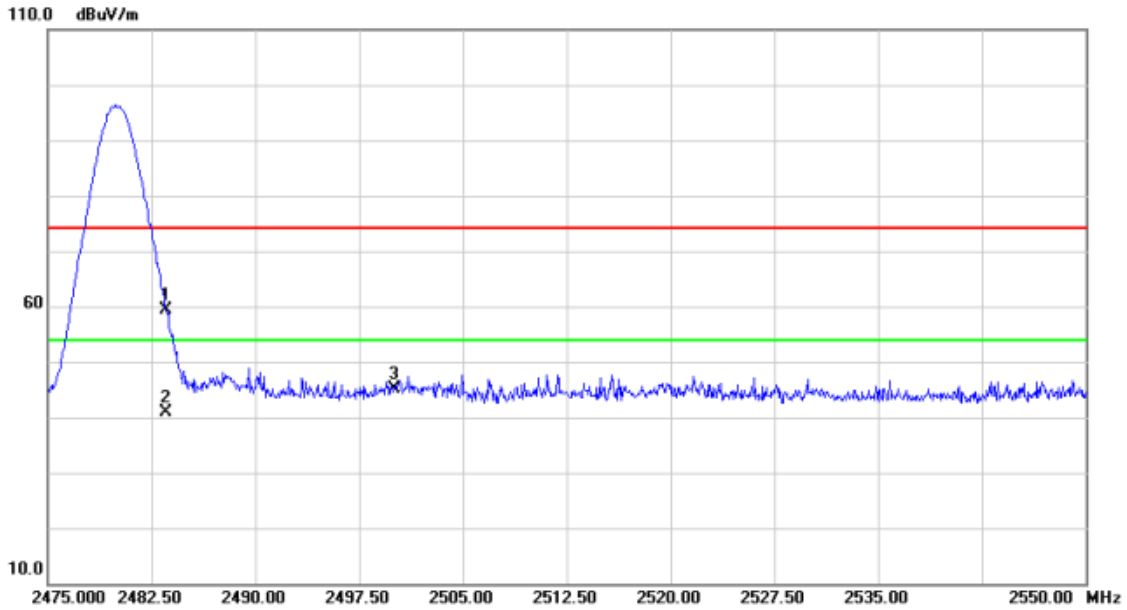
Radiated Emission

No.	Mk.	Freq.	Reading Level	Correct Factor	Measurement	Limit	Over	Antenna Height	Table Degree	
		MHz	dBuV	dB/m	dBuV/m	dBuV/m	dB	cm	degree	Comment
1		2483.500	70.68	-11.28	59.40	74.00	-14.60			peak
2	*	2483.500	52.12	-11.28	40.84	54.00	-13.16			AVG
3		2500.000	56.31	-11.21	45.10	74.00	-28.90			peak

REMARKS:

(1) Measurement Value = Reading Level + Correct Factor.

(2) Margin Level = Measurement Value - Limit Value.

Test Result of Radiated Spurious at Band edges

Test Mode	TX 2480 MHz _CH78_3Mbps	Polarization	Horizontal
-----------	-------------------------	--------------	------------

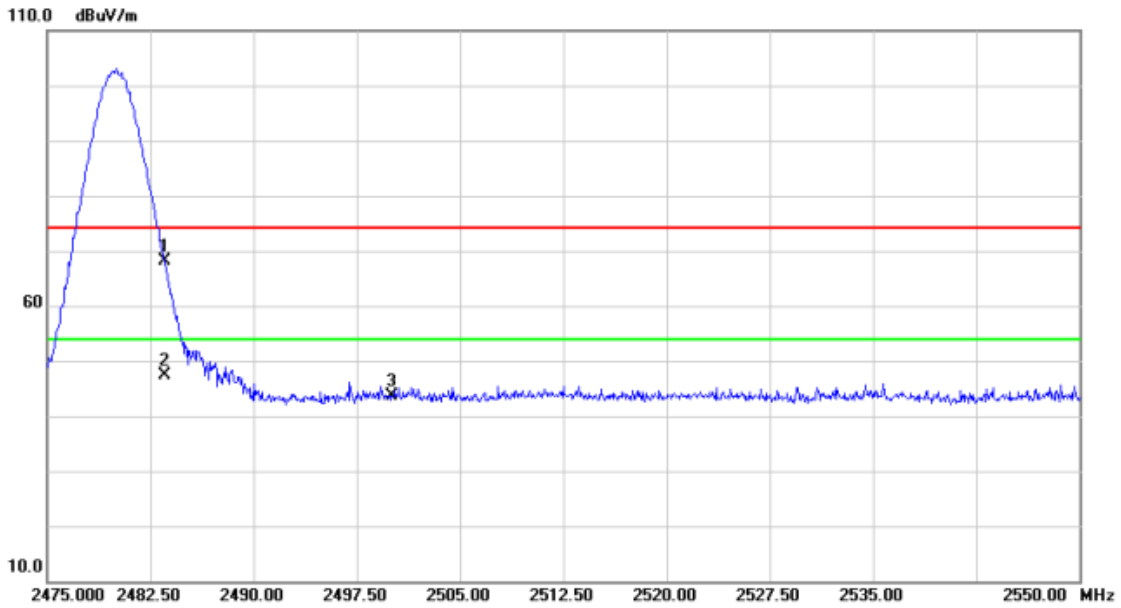
Radiated Emission

No.	Mk.	Freq. MHz	Reading Level dBuV	Correct Factor dB/m	Measure- ment dBuV/m	Limit dBuV/m	Over dB	Detector	Antenna Height cm	Table Degree	Comment
1	*	2483.500	79.35	-11.28	68.07	74.00	-5.93	peak			
2		2483.500	58.61	-11.28	47.33	54.00	-6.67	AVG			
3		2500.000	54.85	-11.21	43.64	74.00	-30.36	peak			

REMARKS:

- (1) Measurement Value = Reading Level + Correct Factor.
 (2) Margin Level = Measurement Value - Limit Value.

ABOVE 1000 MHz
 Modulation Type: DH5(GFSK)

Note: All the modes have been tested and recorded worst mode in the report.

Low channel:2402									
Frequency	Ant.Pol. H/V	Peak reading (dBuV)	AV reading (dBuV)	Correction Factor	Emission Level		Peak Limit (dBuV/m)	AV Limit (dBuV/m)	Margin (dB)
					Peak (dBuV/m)	AV (dBuV/m)			
4804.11	H	60.92	47.35	-1.99	58.93	45.36	74	54	-8.64
7206.00	H	40.60	---	7.14	47.74	---	74	54	-27.26
---	H	---	---	---	---	---	---	---	---
4804.11	V	56.96	42.82	-1.99	54.97	40.83	74	54	-13.17
7206.00	V	39.45	---	7.14	46.60	---	74	54	-27.40
---	V	---	---	---	---	---	---	---	---

Low channel:2441									
Frequency	Ant.Pol. H/V	Peak reading (dBuV)	AV reading (dBuV)	Correction Factor	Emission Level		Peak Limit (dBuV/m)	AV Limit (dBuV/m)	Margin (dB)
					Peak (dBuV/m)	AV (dBuV/m)			
4882.00	H	61.97	48.13	-1.55	60.42	46.58	74	54	-7.42
7323.00	H	42.57	---	8.83	51.40	---	74	54	-22.60
---	H	---	---	---	---	---	---	---	---
4882.00	V	56.87	43.09	-1.55	55.32	41.54	74	54	-12.46
7323.00	V	43.66	---	8.83	52.49	---	75	55	-22.51
---	V	---	---	---	---	---	---	---	---

Low channel:2480									
Frequency	Ant.Pol. H/V	Peak reading (dBuV)	AV reading (dBuV)	Correction Factor	Emission Level		Peak Limit (dBuV/m)	AV Limit (dBuV/m)	Margin (dB)
					Peak (dBuV/m)	AV (dBuV/m)			
4959.307	H	58.14	---	-1.11	57.03	44.52	74	54	-9.48
7440.00	H	42.69	---	9.11	51.8	---	75	55	-23.2
---	H	---	---	---	---	---	---	---	---
4959.307	V	53.44	---	-1.11	52.33	---	74	54	-21.67
7440.00	V	40.47	---	9.11	49.58	---	75	55	-25.42
---	V	---	---	---	---	---	---	---	---

Notes:

- 1). Radiated emissions measured in frequency range from 9 KHz~10th harmonic or 26.5GHz (which is less) were made with an instrument using Peak detector mode.
- 2). Data of measurement within this frequency range shown "----" in the table above means the reading of emissions are attenuated more than 20dB below the permissible limits or the field strength is too small to be measured.
- 3). Measured Level = Reading Level + Correction Factor, Margin = Measured Level – Limit
- 4). Worst case data at 1Mbps at DH5(GFSK).

APPENDIX E - NUMBER OF HOPPING FREQUENCY

Test Mode:	TX Mode_1Mbps
------------	---------------

Test Mode	Antenna	Channel	Result[Num]	Limit[Num]	Verdict
DH5	Ant1	Hop	79	≥15	PASS
2DH5	Ant1	Hop	79	≥15	PASS
3DH5	Ant1	Hop	79	≥15	PASS

Test Graphs

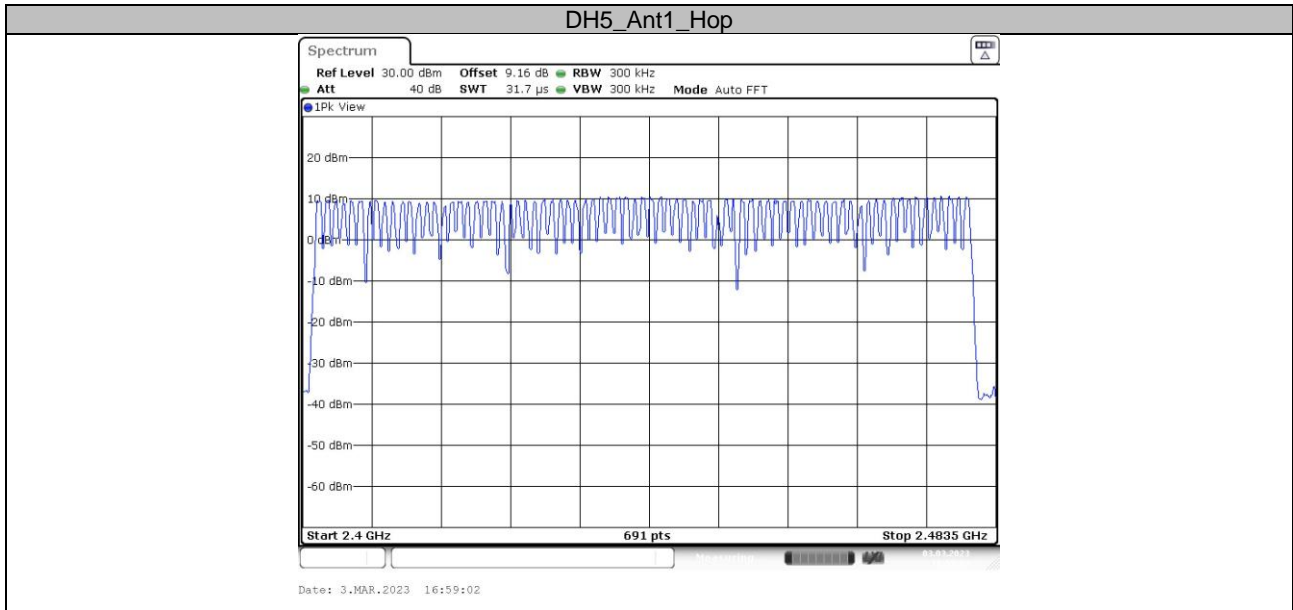

2DH5_Ant1_Hop

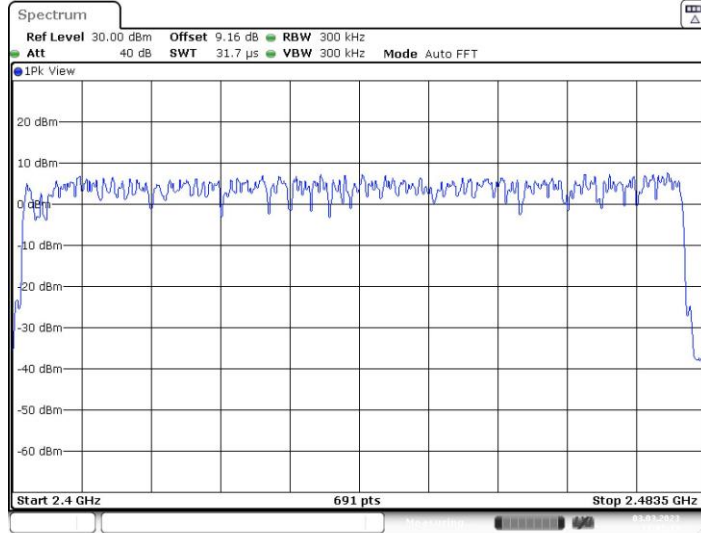

Date: 3.MAR.2023 17:01:13

3DH5_Ant1_Hop

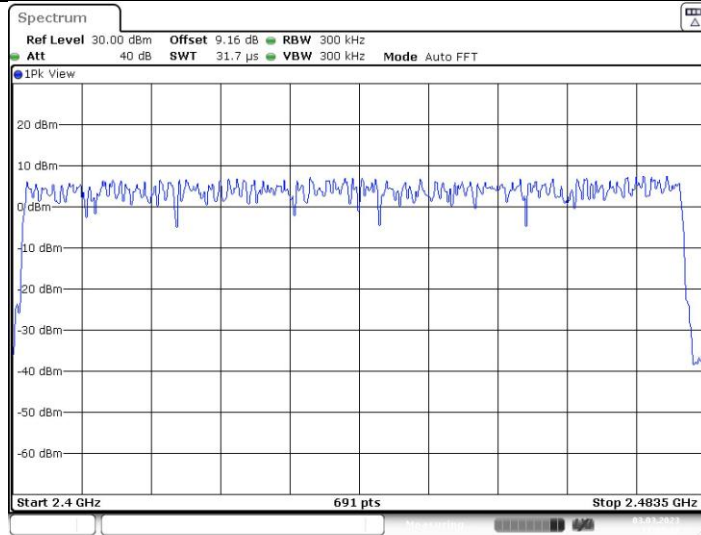

Date: 3.MAR.2023 17:03:32

APPENDIX F - AVERAGE TIME OF OCCUPANCY

Test Mode	Hopping Mode_1Mbps
-----------	--------------------

Test Mode	Antenna	Channel	BurstWidth [ms]	TotalHops [Num]	Result[s]	Limit[s]	Verdict
DH1	Ant1	Hop	0.378	320	0.121	≤0.4	PASS
DH3	Ant1	Hop	1.626	160	0.26	≤0.4	PASS
DH5	Ant1	Hop	2.865	106.67	0.306	≤0.4	PASS
2DH1	Ant1	Hop	0.385	320	0.123	≤0.4	PASS
2DH3	Ant1	Hop	1.630	160	0.261	≤0.4	PASS
2DH5	Ant1	Hop	2.870	106.67	0.306	≤0.4	PASS
3DH1	Ant1	Hop	0.386	320	0.124	≤0.4	PASS
3DH3	Ant1	Hop	1.629	160	0.261	≤0.4	PASS
3DH5	Ant1	Hop	2.872	106.67	0.306	≤0.4	PASS

Test Graphs

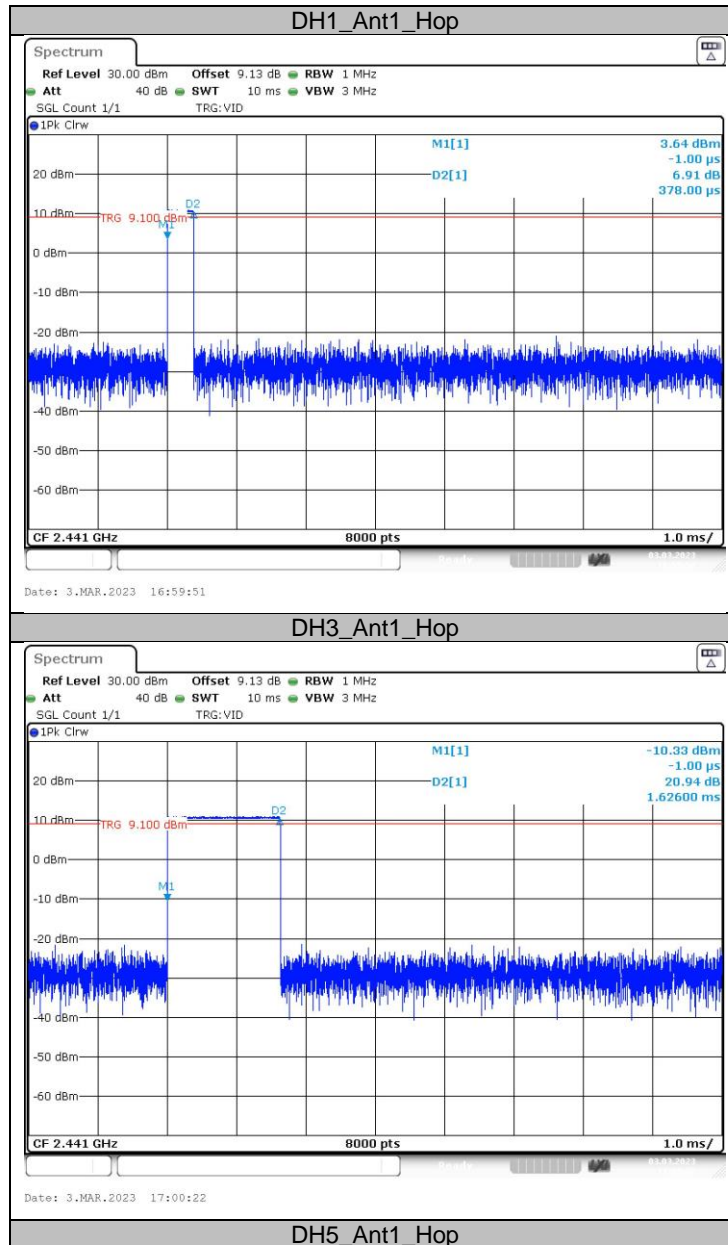

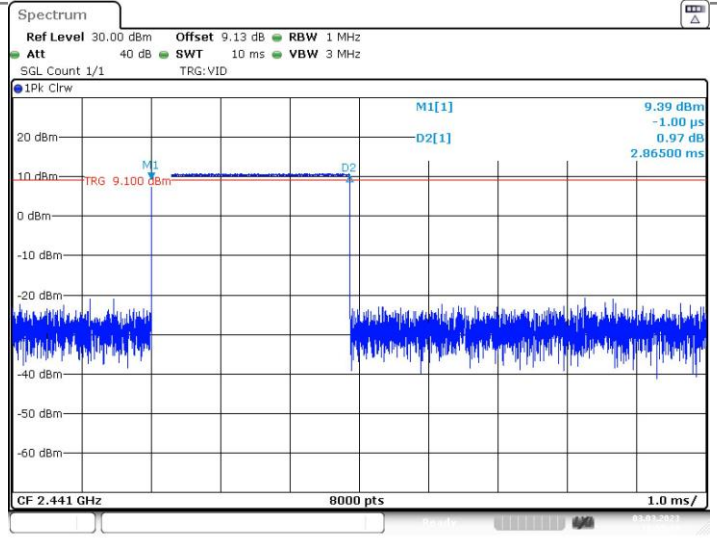

Date: 3.MAR.2023 16:59:18

2DH1_Ant1_Hop

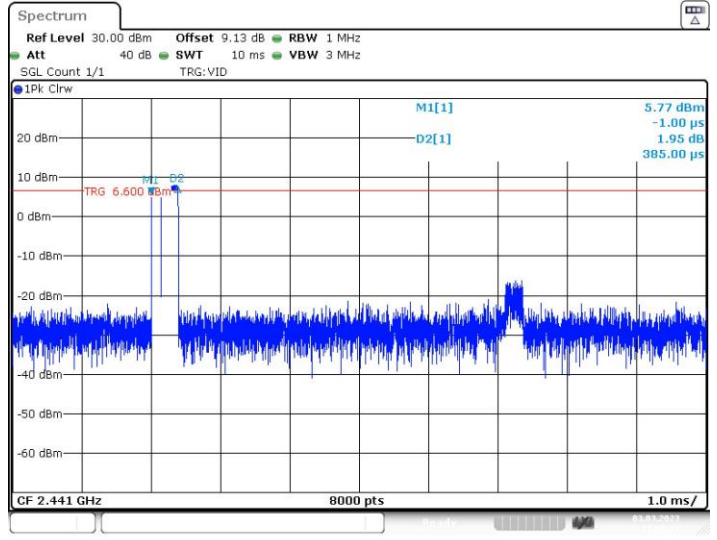

Date: 3.MAR.2023 17:02:11

2DH3_Ant1_Hop

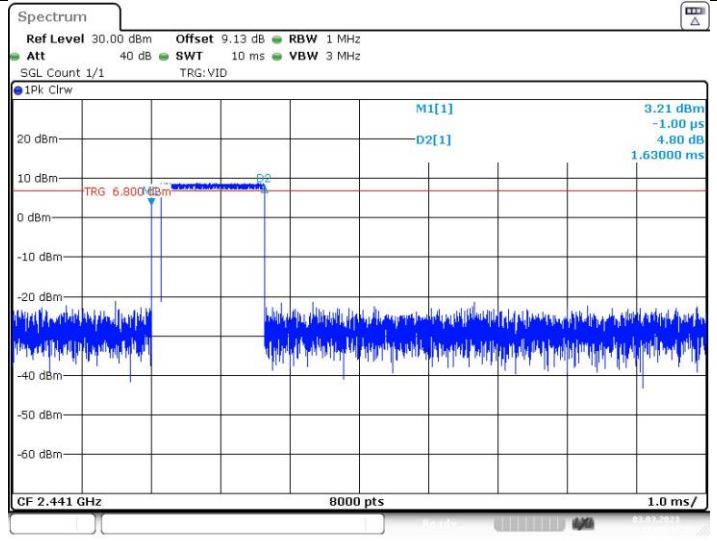

Date: 3.MAR.2023 17:02:41

2DH5_Ant1_Hop

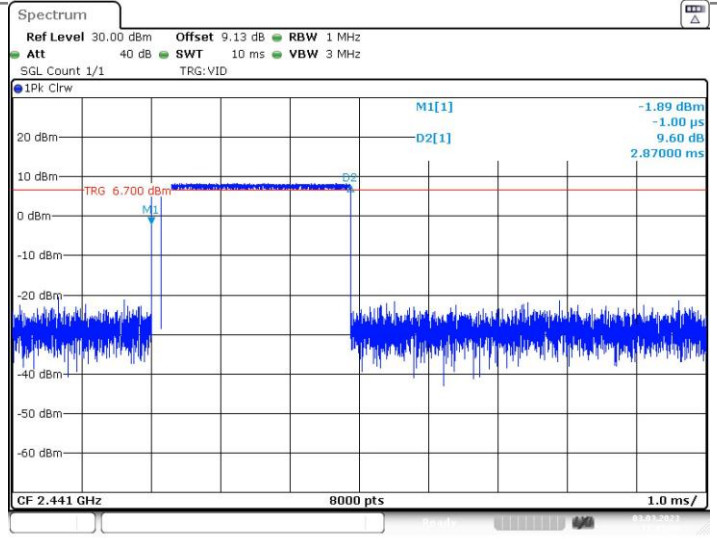

Date: 3.MAR.2023 17:01:29

3DH1_Ant1_Hop

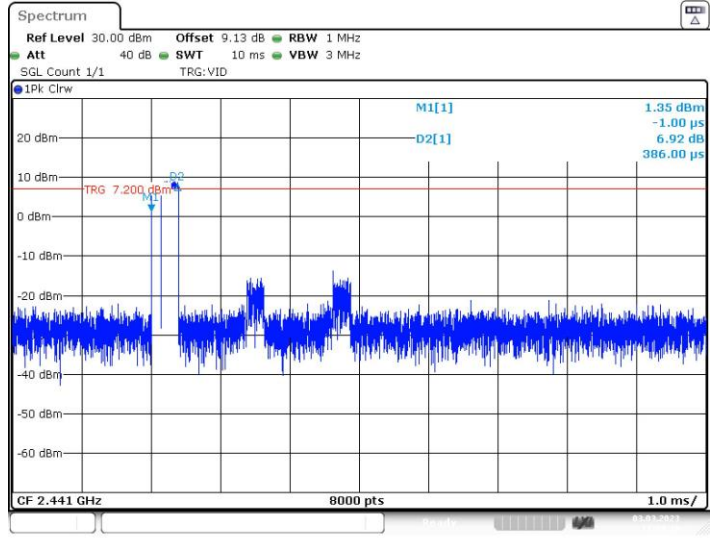

Date: 3.MAR.2023 17:04:16

3DH3_Ant1_Hop

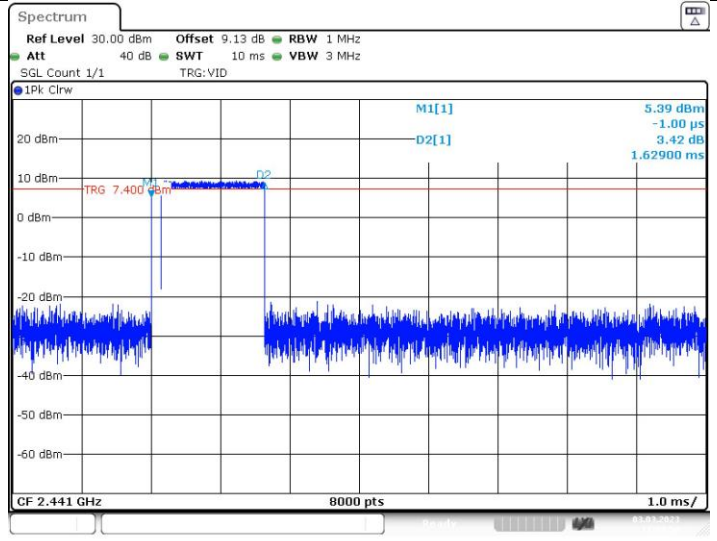

Date: 3.MAR.2023 17:04:50

3DH5_Ant1_Hop

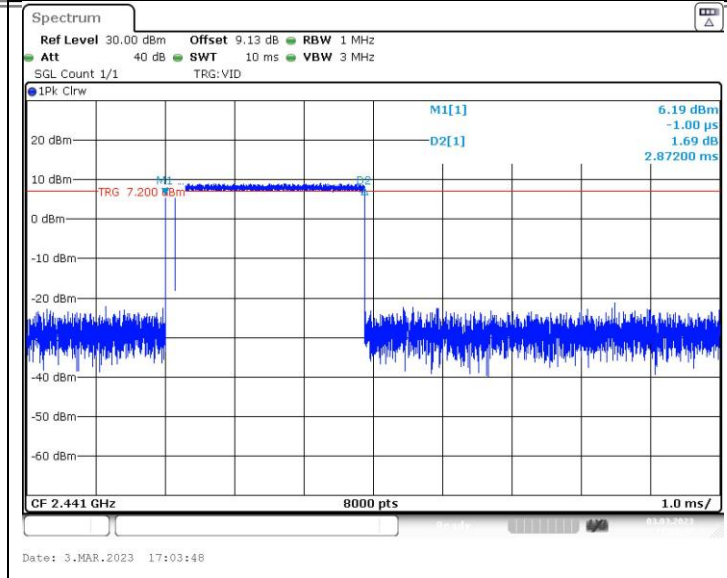

APPENDIX G - HOPPING CHANNEL SEPARATION

Test Mode	Hopping Mode_1Mbps
-----------	--------------------

Test Mode	Antenna	Channel	Result[dBm]	Limit[dBm]	Verdict
DH5	Ant1	Hop	1.009	≥0.981	PASS
2DH5	Ant1	Hop	1.035	≥0.914	PASS
3DH5	Ant1	Hop	1.151	≥0.902	PASS

Test Graphs

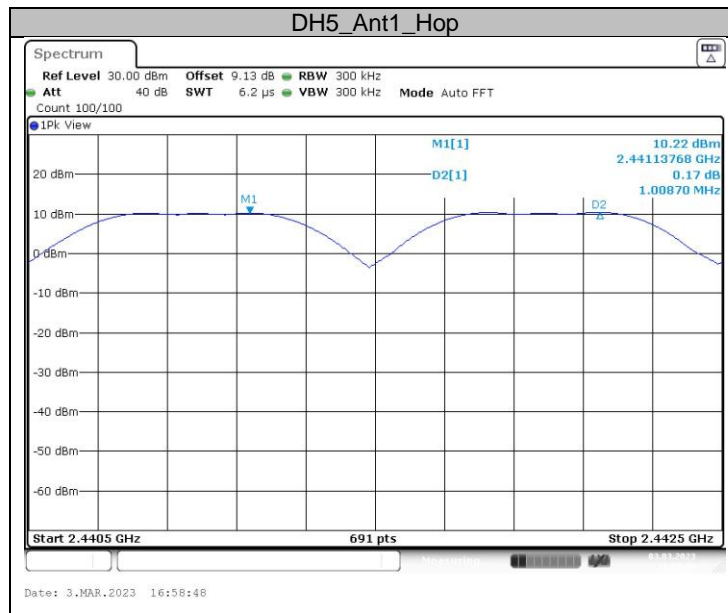

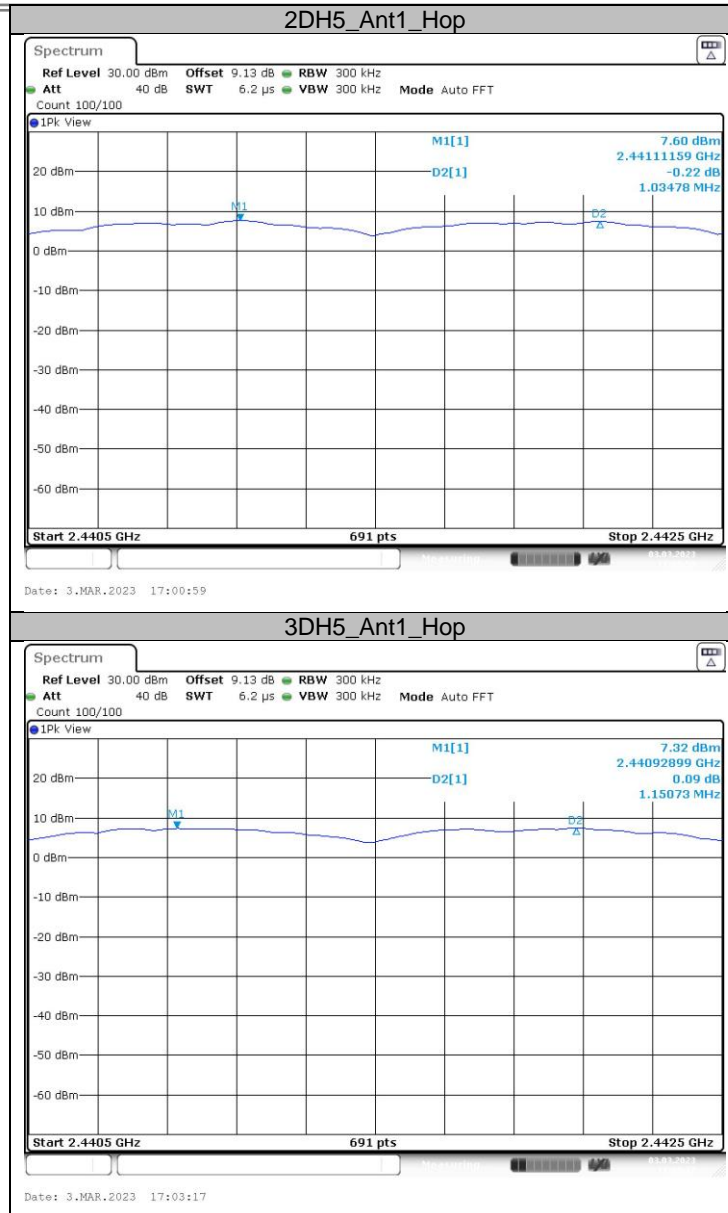

APPENDIX H - BANDWIDTH

20dB Emission Bandwidth

Test Mode	Antenna	Channel	20db EBW[MHz]	FL[MHz]	FH[MHz]	Limit[MHz]	Verdict
DH5	Ant1	2402	0.95	2401.52	2402.47	---	---
		2441	0.94	2440.52	2441.47	---	---
		2480	0.95	2479.52	2480.47	---	---
2DH5	Ant1	2402	1.43	2401.26	2402.70	---	---
		2441	1.44	2440.26	2441.70	---	---
		2480	1.44	2479.25	2480.70	---	---
3DH5	Ant1	2402	1.44	2401.27	2402.71	---	---
		2441	1.44	2440.27	2441.71	---	---
		2480	1.44	2479.27	2480.70	---	---

Test Graphs

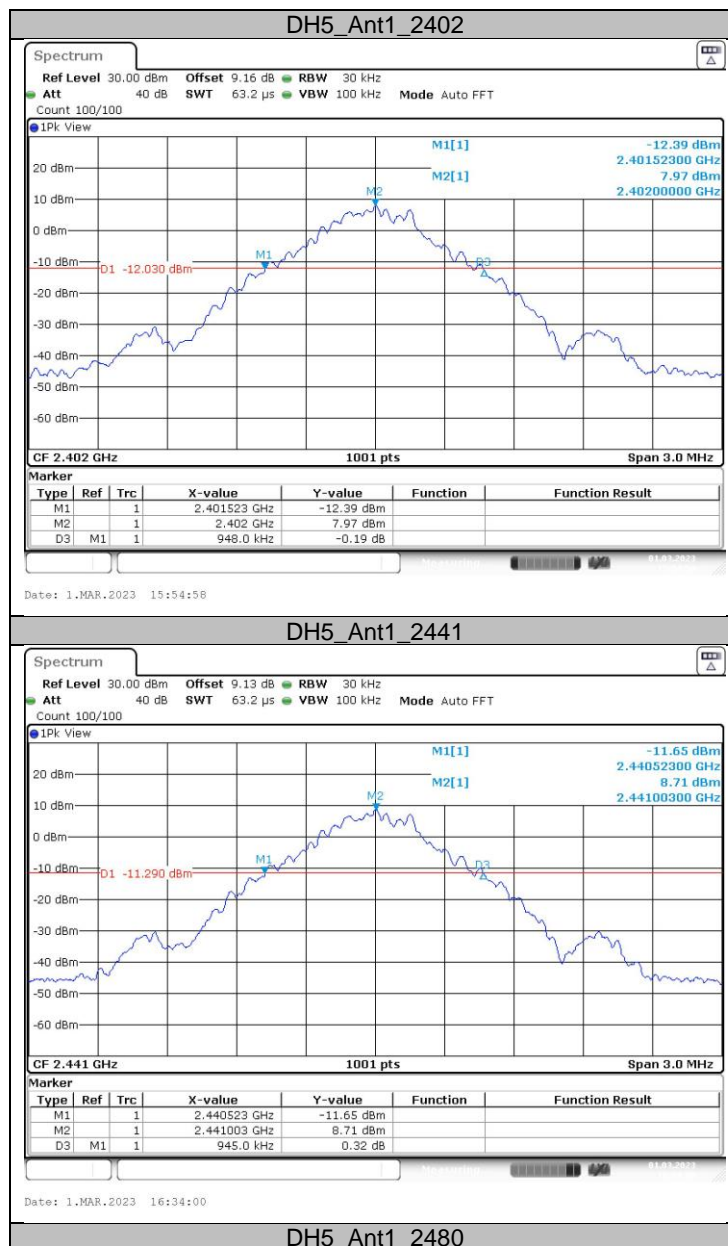

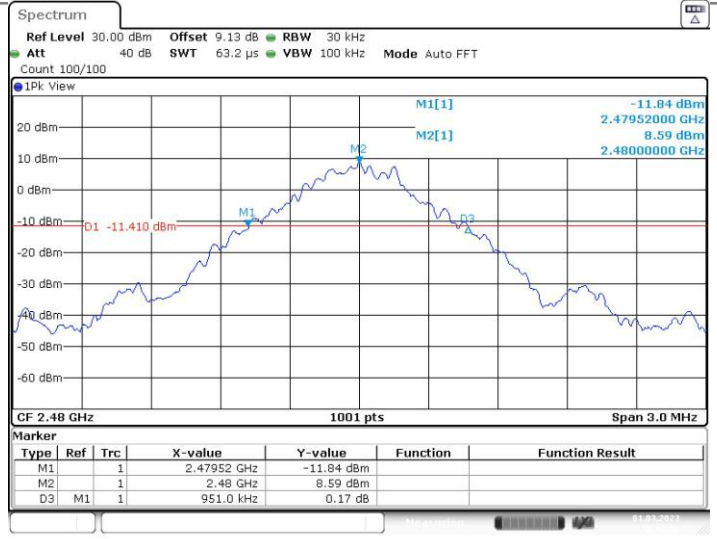

2DH5_Ant1_2402

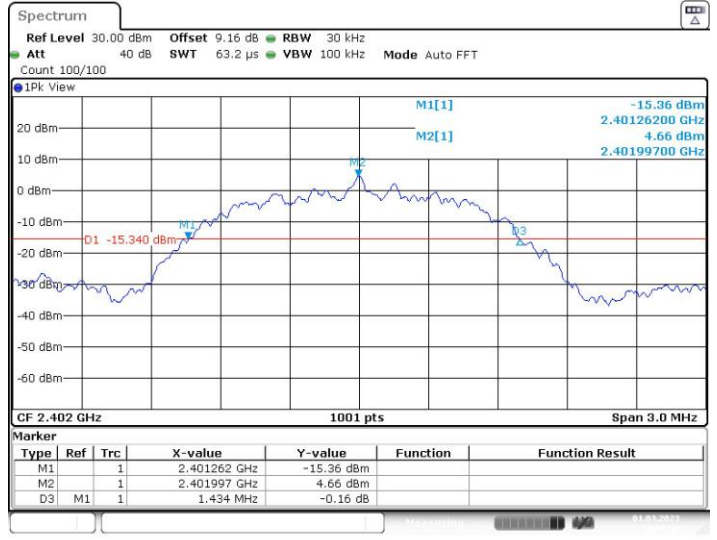

2DH5_Ant1_2441

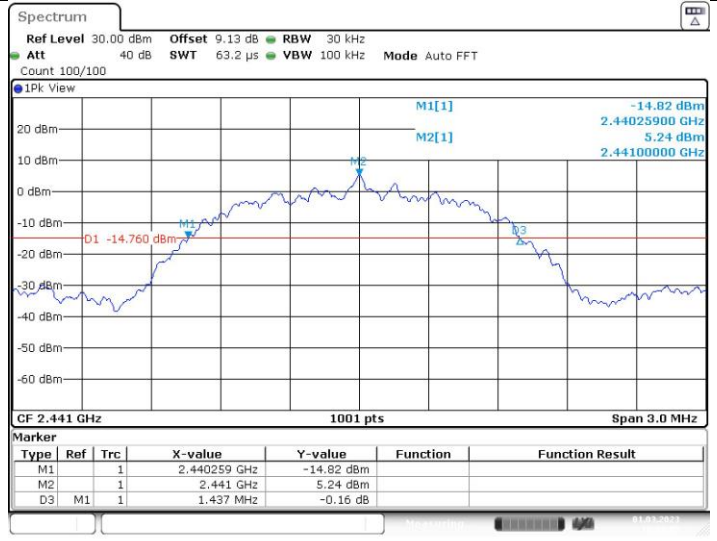

2DH5_Ant1_2480

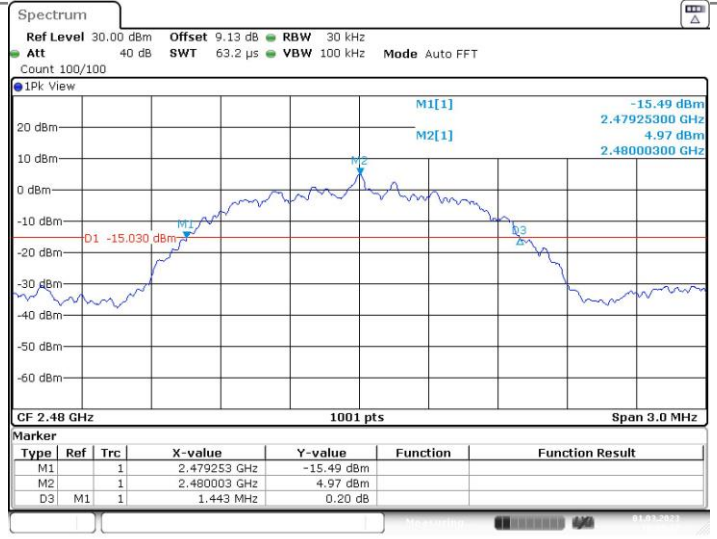

Date: 1.MAR.2023 16:09:37

3DH5_Ant1_2402

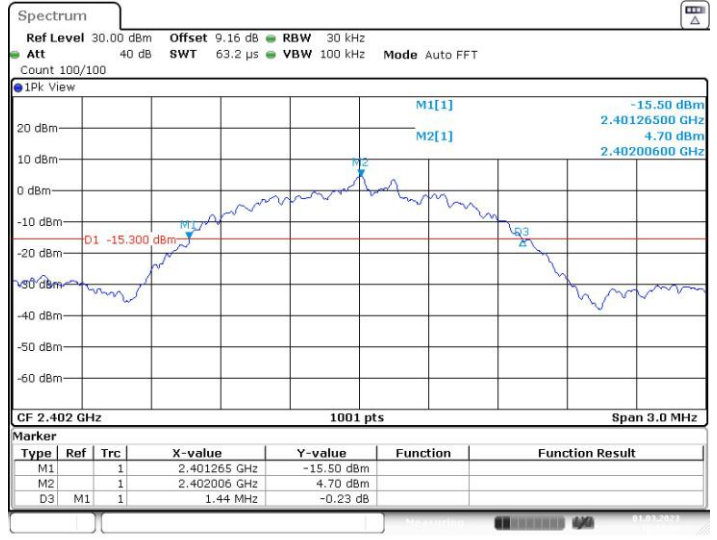

Date: 1.MAR.2023 16:14:29

3DH5_Ant1_2441

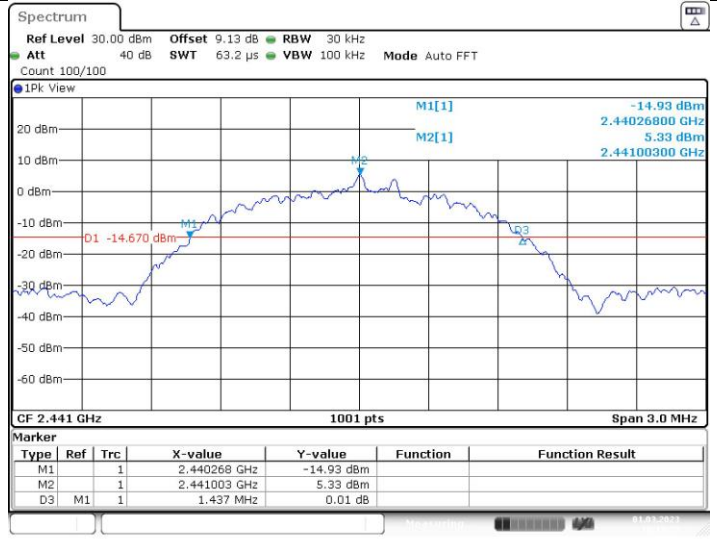

Date: 1.MAR.2023 16:17:26

3DH5_Ant1_2480

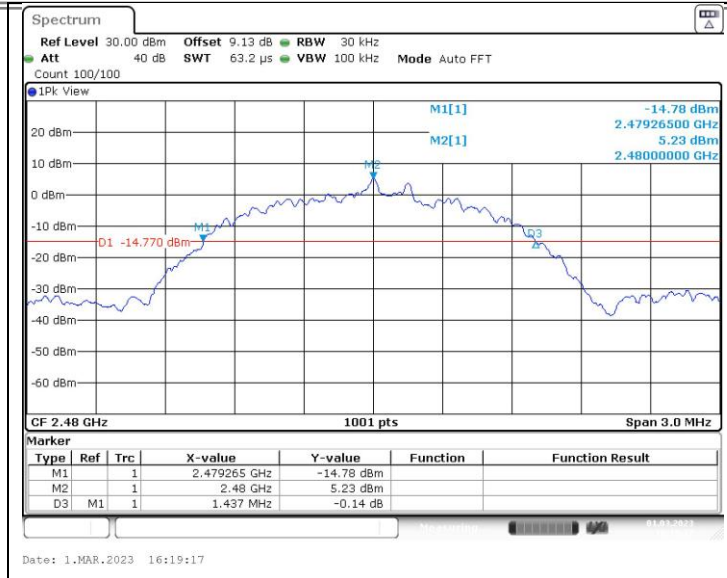

Occupied Channel Bandwidth

Test Mode	Antenna	Channel	OCB [MHz]	FL[MHz]	FH[MHz]	Limit[MHz]	Verdict
DH5	Ant1	2402	0.878	2401.5475	2402.4256	---	---
		2441	0.881	2440.5475	2441.4286	---	---
		2480	0.878	2479.5475	2480.4256	---	---
2DH5	Ant1	2402	1.358	2401.3047	2402.6623	---	---
		2441	1.352	2440.3107	2441.6623	---	---
		2480	1.358	2479.3047	2480.6623	---	---
3DH5	Ant1	2402	1.361	2401.3017	2402.6623	---	---
		2441	1.349	2440.3137	2441.6623	---	---
		2480	1.352	2479.3107	2480.6623	---	---

Test Graphs

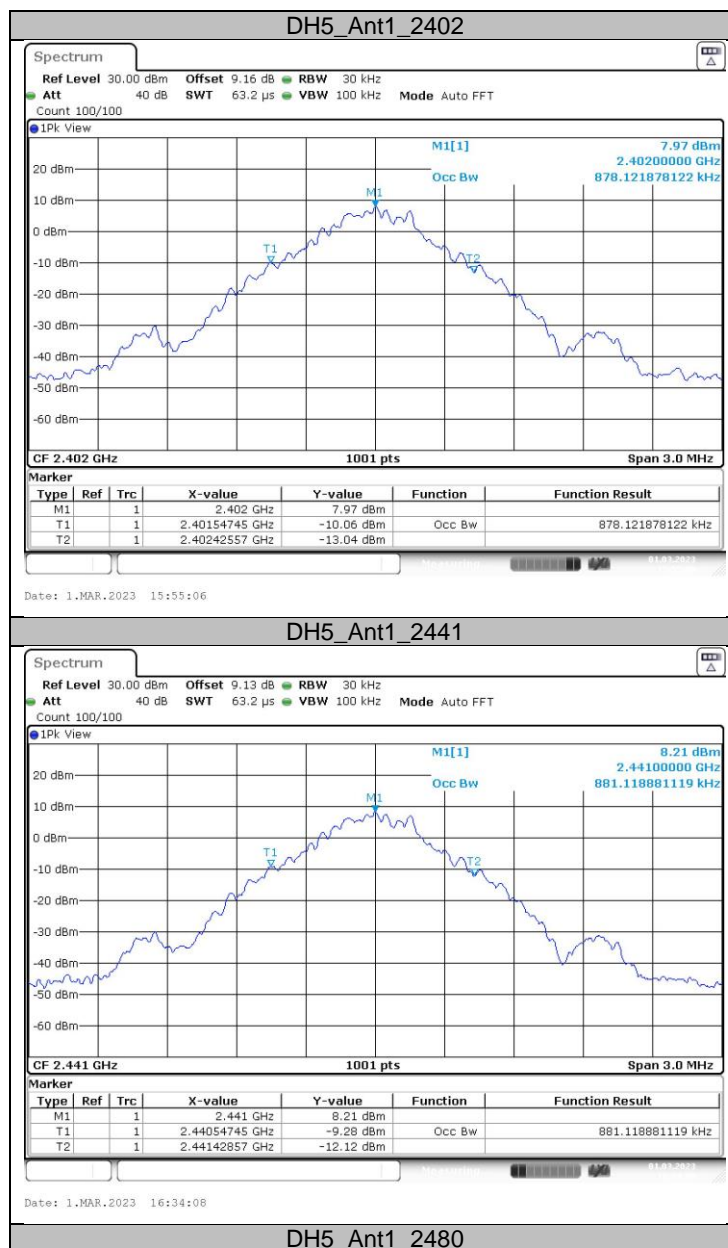

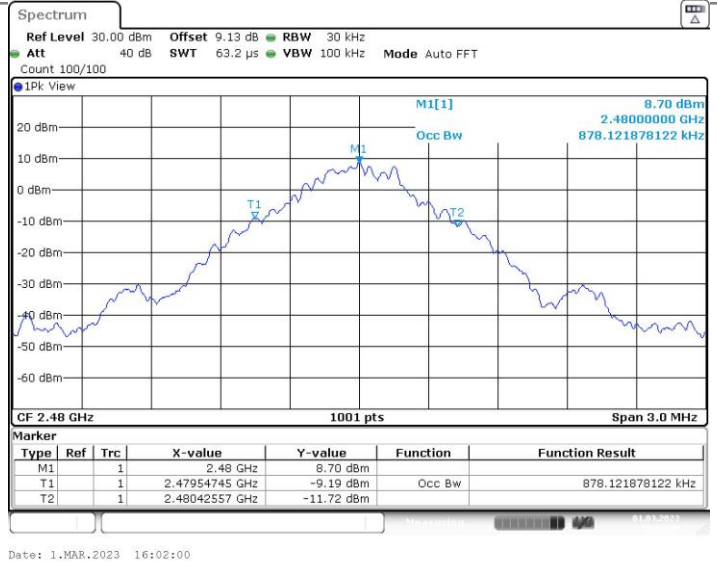

2DH5_Ant1_2402

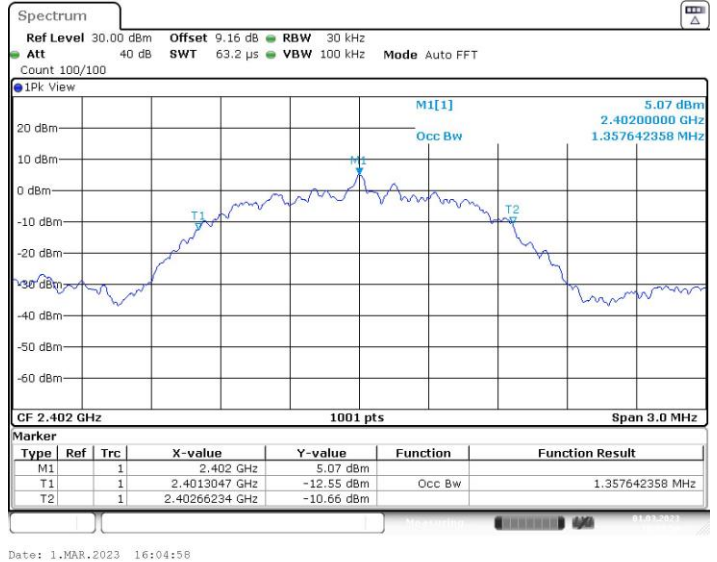

2DH5_Ant1_2441

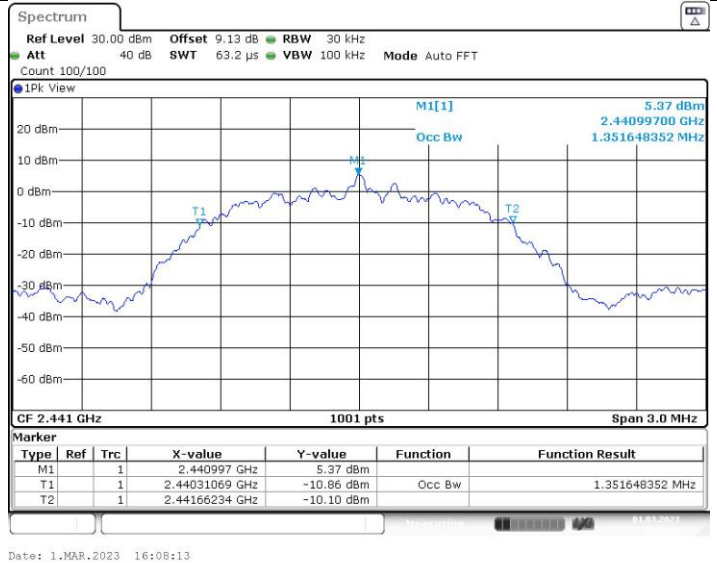

2DH5_Ant1_2480

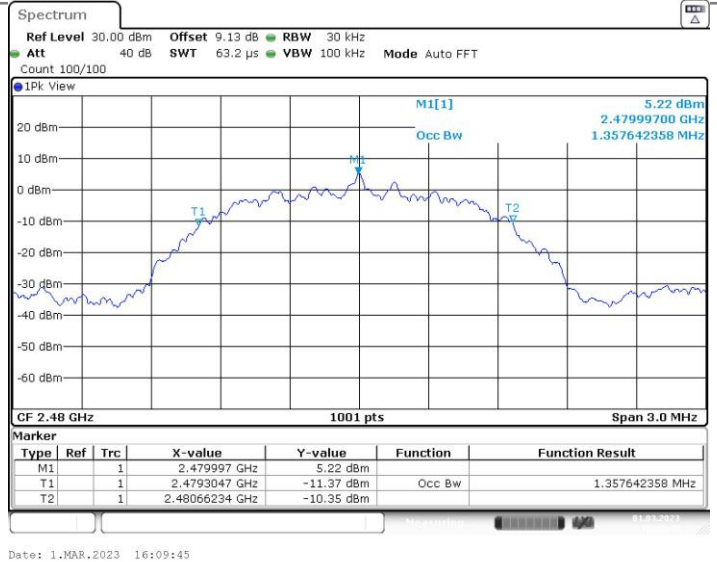

3DH5_Ant1_2402

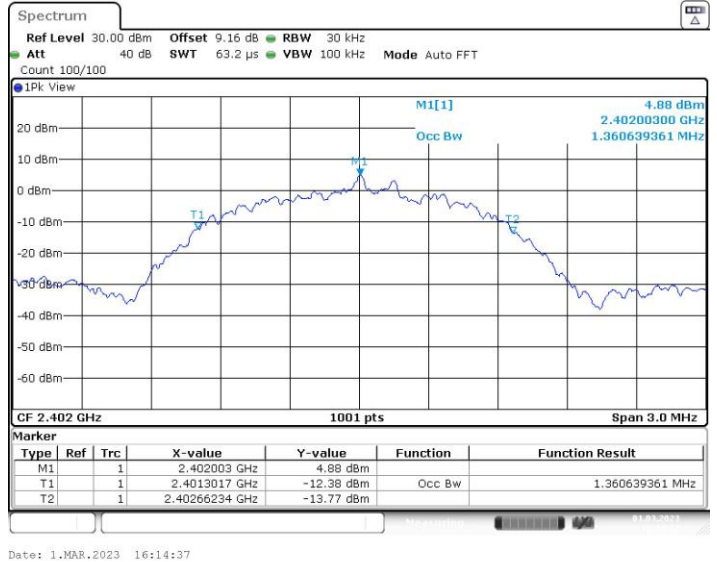

3DH5_Ant1_2441

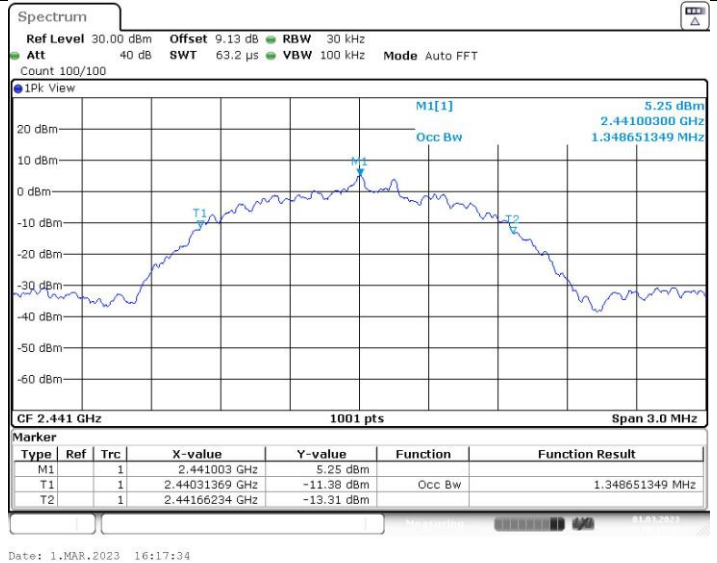

3DH5_Ant1_2480

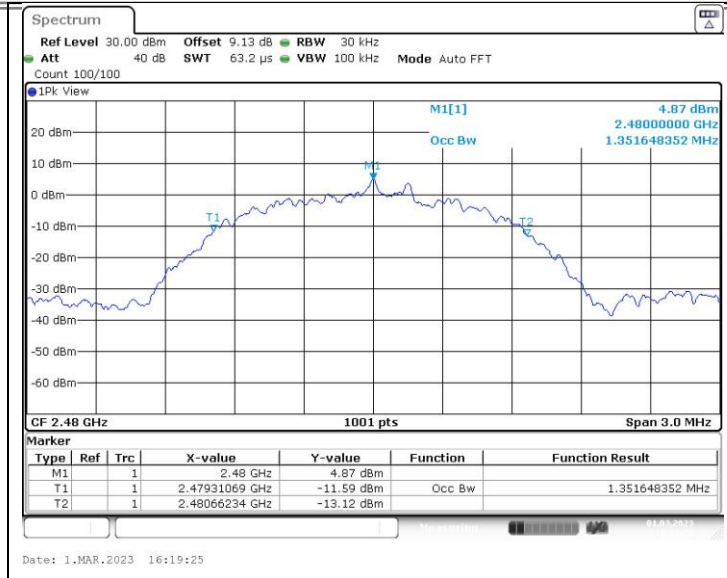

APPENDIX I - MAXIMUM OUTPUT POWER

Test Mode	TX Mode _1Mbps
-----------	----------------

Test Mode	Antenna	Channel	Conducted Peak Power[dBm]	Conducted Limit[dBm]	Verdict
DH5	Ant1	2402	9.74	≤20.97	PASS
		2441	10.38	≤20.97	PASS
		2480	10.49	≤20.97	PASS
2DH5	Ant1	2402	8.38	≤20.97	PASS
		2441	8.92	≤20.97	PASS
		2480	8.79	≤20.97	PASS
3DH5	Ant1	2402	8.45	≤20.97	PASS
		2441	8.98	≤20.97	PASS
		2480	8.87	≤20.97	PASS

Test Graphs

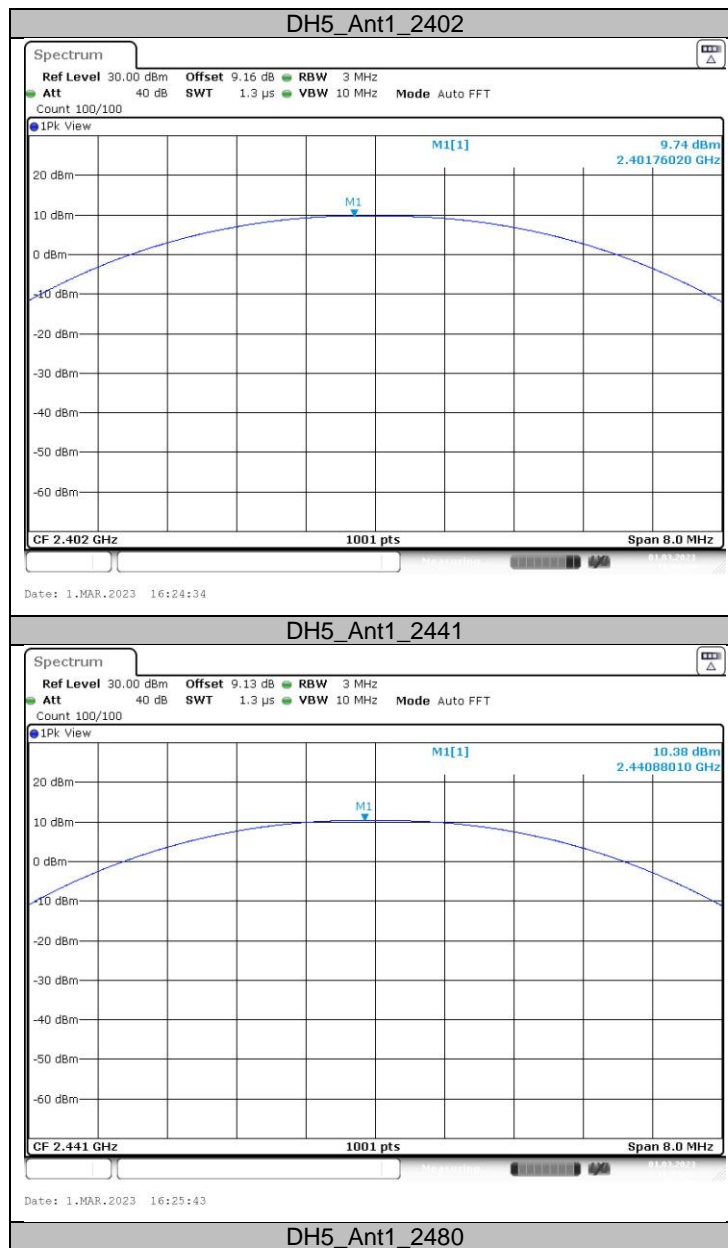

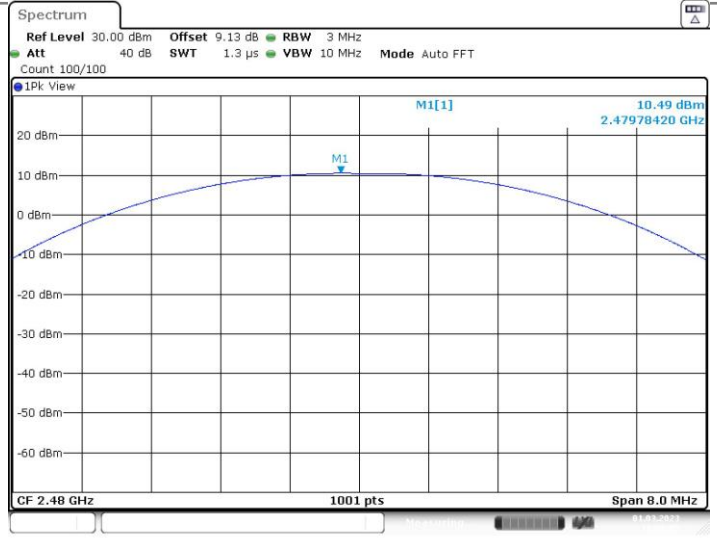

2DH5_Ant1_2402

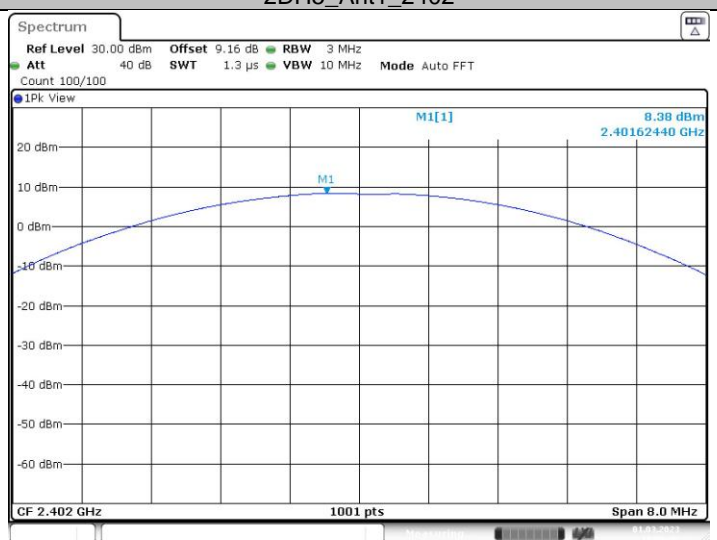

2DH5_Ant1_2441

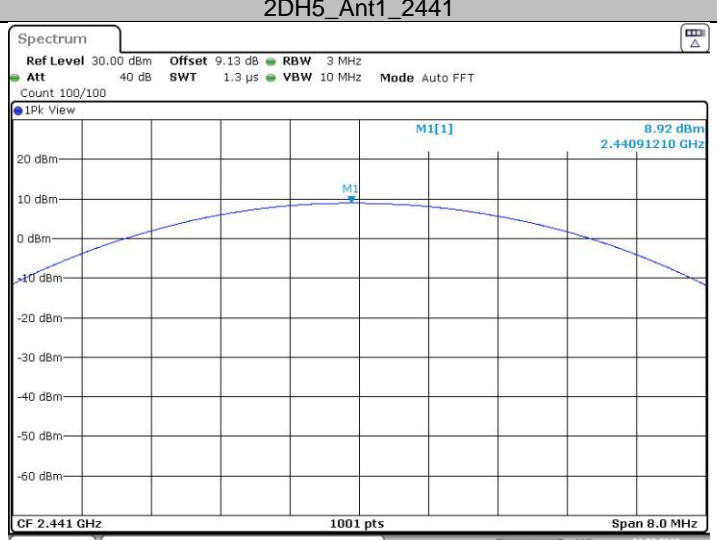

2DH5_Ant1_2480

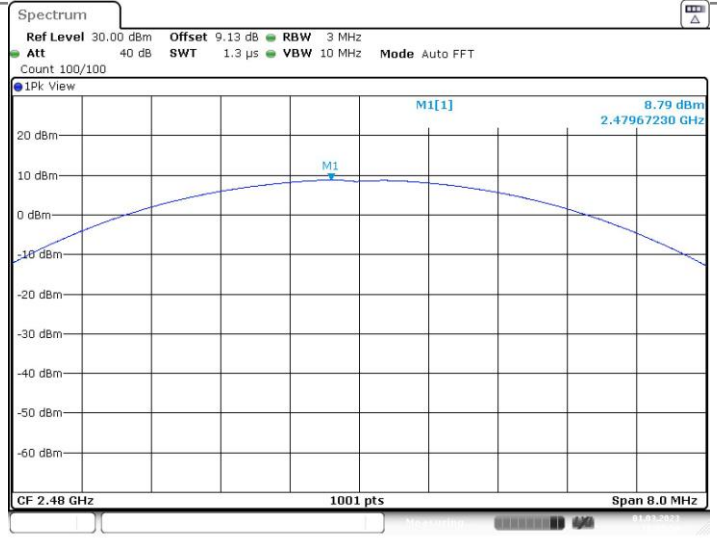

Date: 1.MAR.2023 16:28:58

3DH5_Ant1_2402

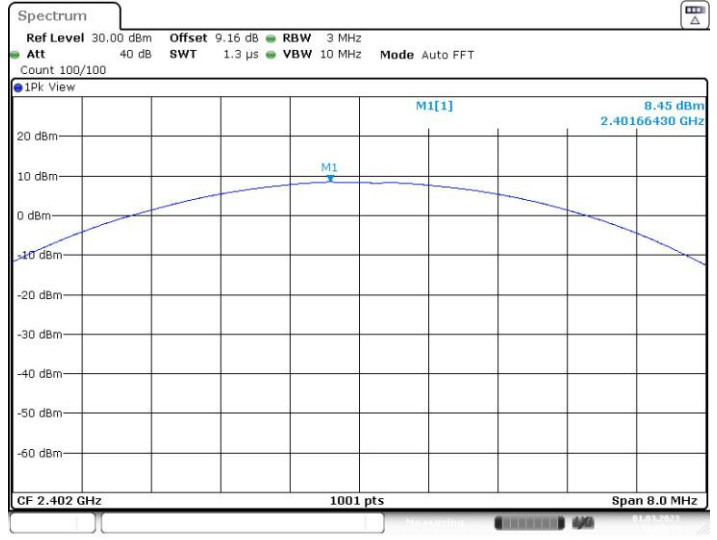

Date: 1.MAR.2023 16:29:45

3DH5_Ant1_2441

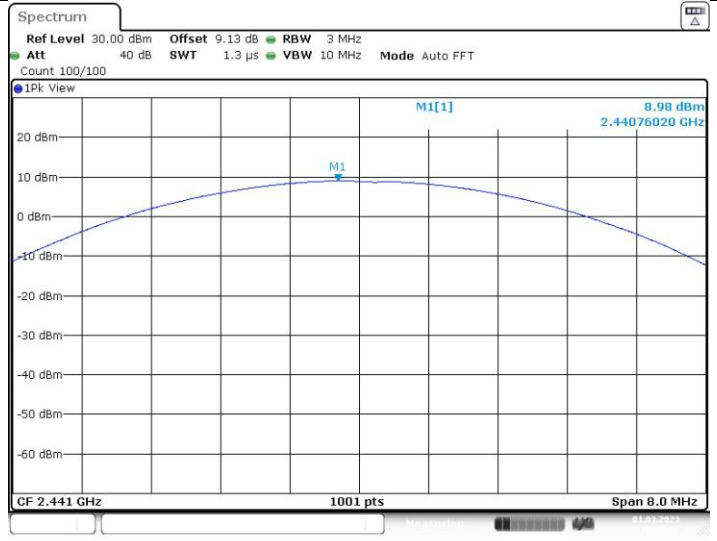

Date: 1.MAR.2023 16:30:51

3DH5_Ant1_2480