

DumbbellConnect™

User Manual

Model: JJ15001

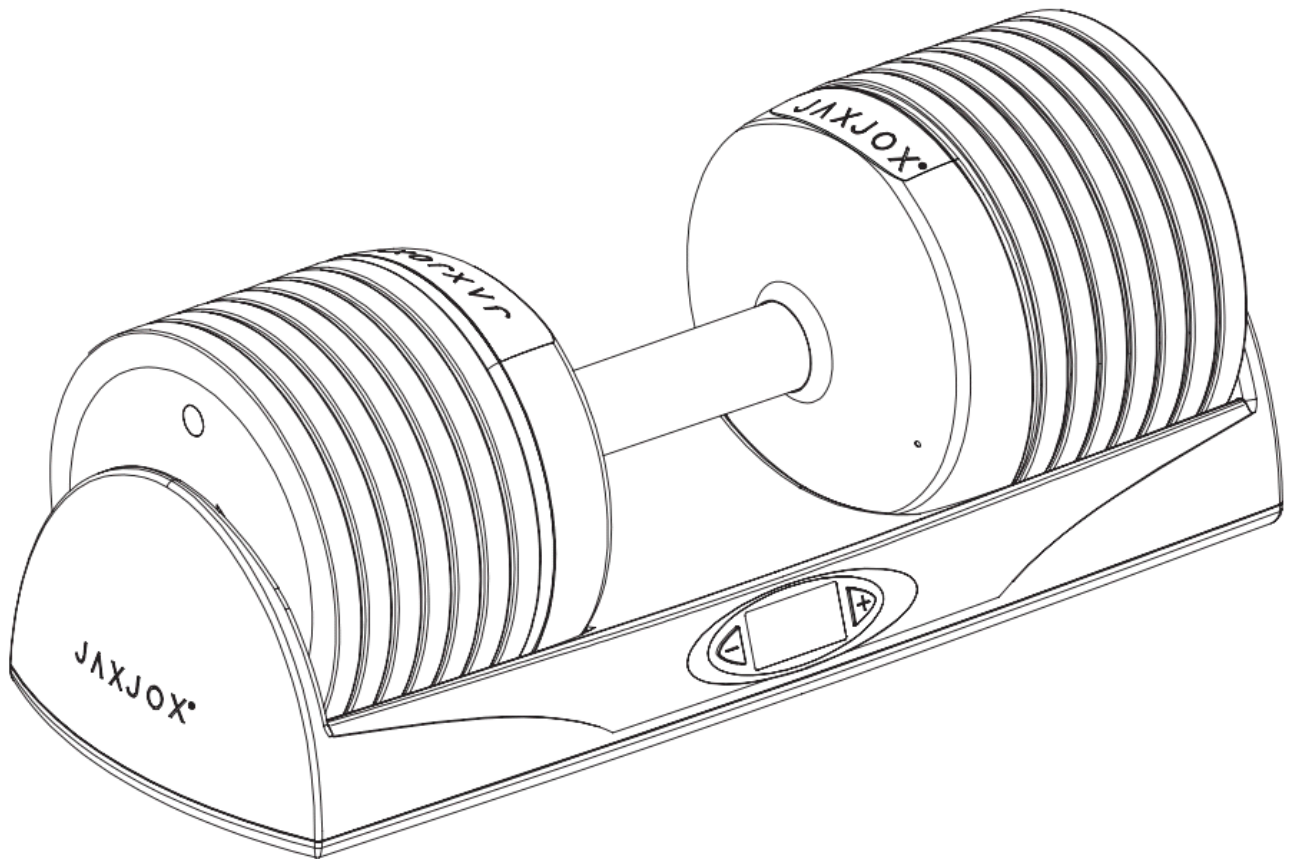

一、 Product Introduction

Thank you for choosing our Bluetooth Smart Dumbbell which is an innovative training tool for sports series manufactured by our company. With exquisite design and advanced technology, the weight of Smart Dumbbell can be adjusted from 8 pounds (3.6 kg) to 50 pounds (22.7 kg). You can set goals, track training, and fully master your fitness quality level at the JAXJOX® Fitness IQTM because the Smart Dumbbell can connect to JAXJOX® APP via Bluetooth Low Energy.

※ This product needs to be charged and activated before first use. It is recommended to fully charge the battery before use.

This product manual will make you better understand our Smart Dumbbell. Please keep it for future reference.

- Our products are not intended to provide medical advice, is only to show you the exercise date.

二、 Product Accessories

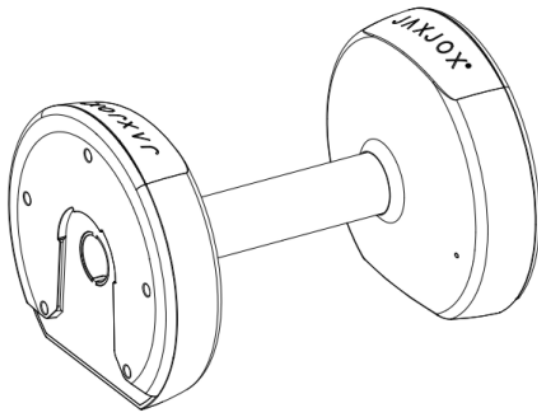

Handle

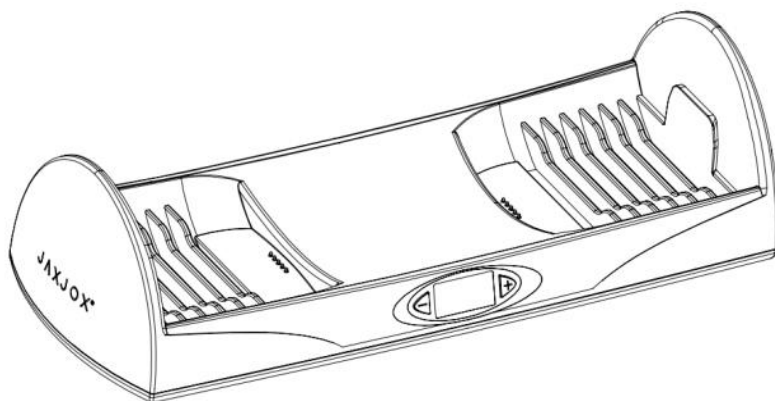

Base

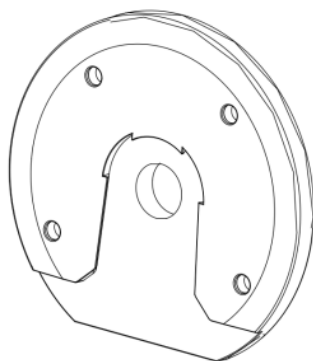

weightsX14

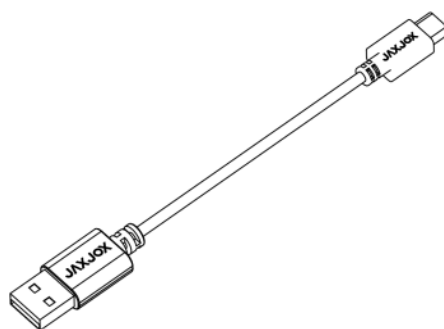

Charging Cable &USB TYPE-C

Carefully remove all items from the box and place them on the floor prior to assembly. Verify that all of the components have been included.

Should you find any parts missing, return the product to your point of purchase or contact JAXJOX at:

Customer.services@jaxjox.com or (425)324-3017

三、 The installation step of Dumbbell.

1. Place the base on a firm level surface

We recommend that you use and store your dumbbells horizontally to minimize the risk of injury.

2. Charging Dumbbell

- Plug the USB cable into the charger
- Insert the other end of the USB cable into the Dumbbell base
- Plug the charger into the power socket

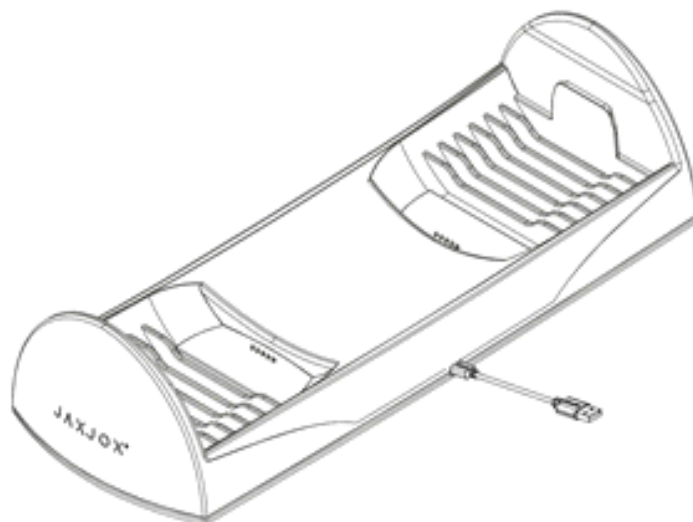

(1) When the base battery is low, the display screen showing as follows, please charge it in time.

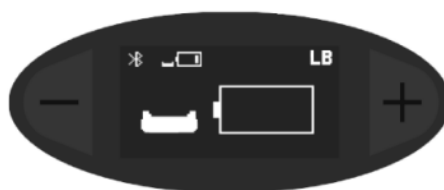

:

(2) When the shell battery is low, the display showing as follows, please charge it in time.



:

3. Weight stacked

Make sure the weight slot faces directly to the side and to the wing plate of the base.

Place weights in turn, making sure there is no space between each weight.

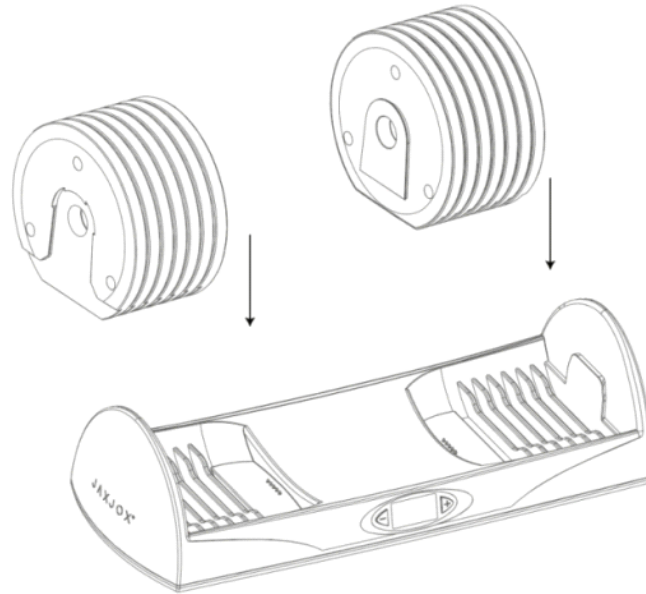

4. Place the dumbbell handle on the base

(1) Place the handle on top of the weight, make sure the dumbbell handle is aligned with the base wing .

(2) The dumbbells will beep when in right place and ready to use .

- **Note:** weights must be stacked symmetrically so that dumbbell can be connected and work properly. Improper assembly of weights and dumbbell handles can damage dumbbell connections or cause serious injury .

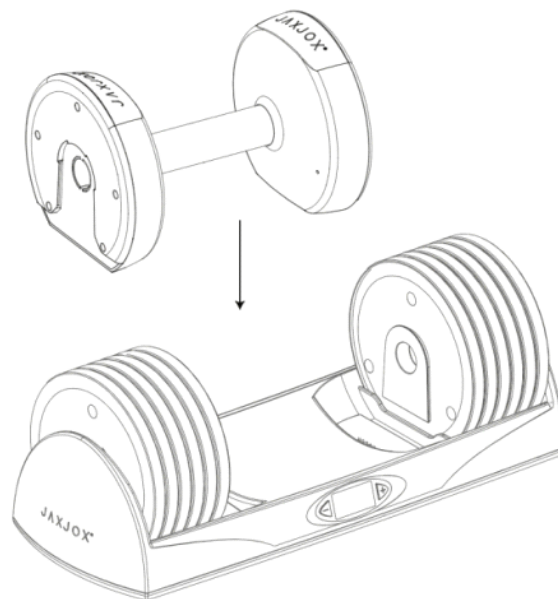

四、LCD

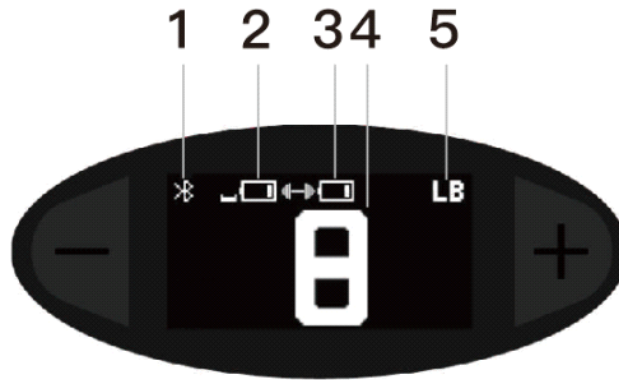

1. Bluetooth icon (If the Smart Dumbbell connect the Bluetooth, the icon always on/otherwise not)
2. Base battery Icon
3. Handle battery Icon
4. Value of weight (The default weight is 8 LB if it is not set)
5. Unit of weight (LB / KG)

五、Download and install APP

Search "JAXJOX" from APP Store, and install.

六、Bluetooth Connection

- Open Bluetooth in your phone
- Open "JAXJOX" App
- Click " Connect", Select Device, the Bluetooth icon will not flash if connect successfully.
- Check the data after connecting with the APP.

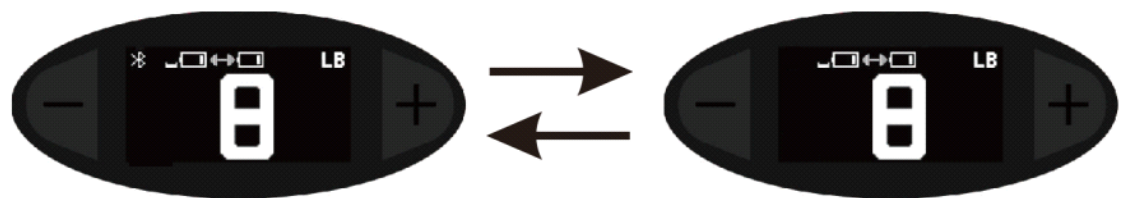

Connected

Disconnected

Note:

Verify the Kettlebell has been added in JAXJOX app.
 Verify Bluetooth is enabled on your mobile device

- **How to use Dumbbell**

7-1. Start the dumbbell

(1) Press the button of - or + on the base to activate the dumbbell.

(2) The screen displays  icon, reminding you that you need to connect to the JAXJOX application.



7-2. The unit settings

Press and hold either the [+] or [-] button for two seconds, then enter into the weight unit setting interface, the unit icon [LB] or [KG] in the upper right corner flashes, press the [+] or [-] button to switch the unit, and it will automatically determine if there is no operation for a short time.

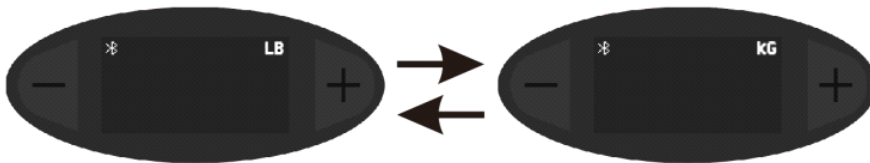

7-3. Setting up the weight

- Press **[+]** or **[-]** to choose the desired weight for your workout..
The device can be adjust from
8lb (3.6kg) — 14lb (6.4kg) — 20lb (9.1kg) — 26lb (11.8kg) — 32lb (14.5kg) — 38lb (17.2kg) — 44lb (20kg) 50lb (22.7kg)
- The Dumbbell connect takes approximately 3 seconds to change to your selected weight. The weight loading animation plasy while the weight is adjusting. Do not move the Dumbbell connect while it is adjusting.
- The Dumbbell will beep once when ready for use.



Note: If the weight of the handle does not match the weight displayed on the base, please put back the handle and reset the weight according to the above steps.

7-4. Precautions before Dumbbell training

Before starting your workout, ensure your environment is free of anything that may interfere with your movements.

Do not drop the Dumbbell or use excessive force when moving the Dumbbell.

IMPORTANT: Do not attempt to adjust any of the mechanisms on the underside of the Dumbbell. Do not attempt to manually adjust the weight on the Dumbbell shell. Doing so may result in serious injury and /or device malfunction.

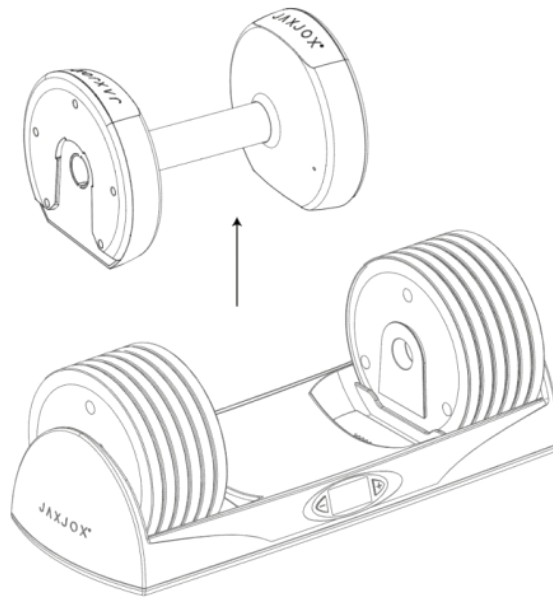

7-5. Handle and Base (Disconnect and Connect)

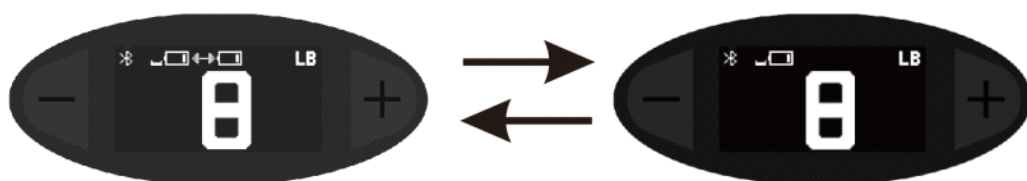

显

Display for the handle/base connected and disconnected:

(1) Handle and base connected,  icon display;

(2) Handle and base disconnected,  icon not display;

(3) During charging  icon display; without charging,  icon not display;

If the handle and base connected, it will see the battery icon in the screen.

If the handle and base disconnected, it will not see the battery icon in the screen.

(4) Handle and Base disconnected reminder: If the handle and base disconnected more than 24 hours, then the display will reminder the user to put back the handle. Every 2 seconds and 1 second are displayed alternately. The buttons have no function. Putting the handle back to the base will return to the main page.

Press the button when there is no host:
Display prompt cycle twice (cancel alarm)

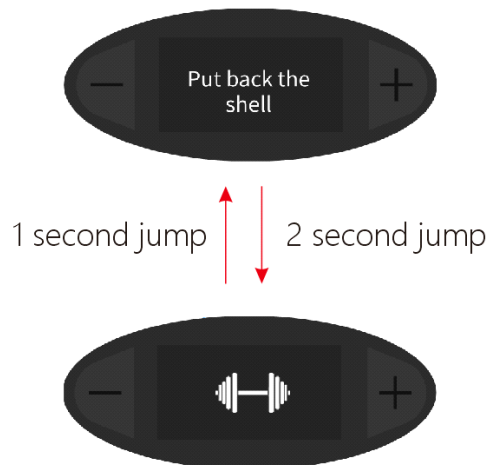

7-6. Reset the dumbbell

Resetting the device may correct equipment problems if your dumbbell with something wrong.

To reset the dumbbells, press the reset button below the base, which is highlighted in the figure.

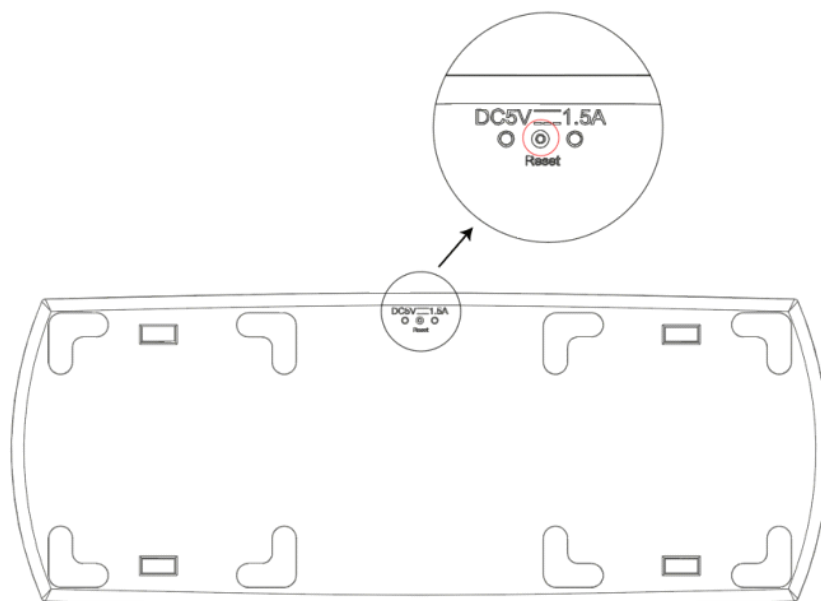

7-7. Enter into Sleep Mode

Without any operation, it enters into sleep mode after 20 seconds, and the backlight turns off.

八、Disclaimer

- The products are subject to change due to the manufacturer's ongoing research and development plans without prior notice.

Our Company makes no representations or warranties as to this user manual or the product we described.

- Our Company shall not be liable for any direct or indirect, accidental or special damages, losses or expenses arising out of or in connection with this user manual or the product we described

Routine maintenance and things to note.

- This product is not waterproof. Do not use our product outdoors on rainy days
- Wiping handle with dry cloth. Please do not make the Smart Dumbbell touch water
- Assessing your condition carefully before exercising, Warm up first.

If it does not work properly, try the methods as following:

- It should be charged in time, and whether the mobile phone Bluetooth is on or not.

- Turn off and restart your mobile phone's Bluetooth
- Reboot your mobile phone
- Reset the Smart Dumbbell and reconnect Bluetooth

Product Parameter

Product model :

Handle size : 495.3X190.5X174.9mm

Base size: 495.3X190.5X122.4mm

Product Net Weight: 47.4kg

Wireless connection: Bluetooth

APP: [iOS 13.0+](#); [Android 4.4+](#);

Both the base and the dumbbell handle are lithium batteries, and the base can charge for the handle.

Beep sound alert

It is displayed When the dumbbell handle is placed in the base. Otherwise is not displayed.

Dumbbell handles can standby for up to 14 days.

EU-DECLARATION OF CONFORMITY

Hereby, We, declares that **DumbbellConnect™ (model: JJ15001)** is in compliance with the essential requirements and other relevant provisions of Directive RED 2014/53/EU. A copy of the signed and dated Declaration of Conformity is available.

FCC STATEMENT

This device complies with Part 15 of the FCC Rules. Operation is subject to the following two conditions: (1) This device may not cause harmful interference, and (2) This device must accept any interference received, including interference that may cause undesired operation.

WARNING: Changes or modifications not expressly approved by the party responsible for compliance could void the user's authority to operate the equipment.

NOTE: This equipment has been tested and found to comply with the limits for a Class B digital device, pursuant to Part 15 of the FCC Rules. These limits are designed to provide reasonable protection against harmful interference in a residential installation.

This equipment generates, uses and can radiate radio frequency energy and, if not installed and used in accordance with the instructions, may cause harmful interference to radio communications. However, there is no guarantee that interference will not occur in a particular installation. If this equipment does cause harmful interference to radio or television reception, which can be determined by turning the equipment off and on, the user is encouraged to try to correct the interference by one or more of the following measures:

1. Reorient or relocate the receiving antenna.
2. Increase the separation between the equipment and receiver.
3. Connect the equipment into an outlet on a circuit different from that to which the receiver is connected.
4. Consult the dealer or an experienced radio/TV technician for help.

