

## TEST REPORT

**Applicant:** MAXWEST COMMUNICATION LIMITED

**Address:** FLAT/RM 707 7/F, FORTRESS TOWER 250 KING'S ROAD,  
NORTH POINT, HONG KONG

**Product Name:** Phone

**FCC ID:** 2ASP8NEON3

**Standard(s):** 47 CFR Part 15, Subpart C (15.247)  
ANSI C63.10-2020  
KDB 558074 D01 15.247 Meas Guidance v05r02

**Report Number:** 2502T01066E-RF-00A

**Report Date:** 2025/6/16

The above device has been tested and found compliant with the requirement of the relative standards by Bay Area Compliance Laboratories Corp. (Dongguan).

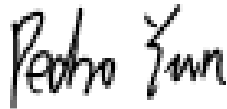

**Reviewed By:** Pedro Yun  
Title: **Project Engineer**

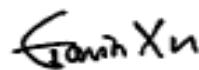

**Approved By:** Gavin Xu  
Title: **RF Supervisor**

---

**Bay Area Compliance Laboratories Corp. (Dongguan)**  
No.12, Pulong East 1<sup>st</sup> Road, Tangxia Town, Dongguan, Guangdong, China

Tel: +86-769-86858888

Fax: +86-769-86858891

[www.baclcorp.com.cn](http://www.baclcorp.com.cn)

Note: The information marked ▲ is provided by the applicant, the laboratory is not responsible for its authenticity and this information can affect the validity of the result in the test report. Unless otherwise stated the results shown in this test report refer only to the sample(s) tested. This report cannot be reproduced except in full, without prior written approval of the Company. This report is valid only with a valid digital signature. The digital signature may be available only under the Adobe software above version 7.0. This report may contain data that are not covered by the accreditation scope and shall be marked with ★. This report must not be used by the client to claim product certification, approval, or endorsement by NVLAP, NIST, or any agency of the U.S. Government. Each test item follows the test standard(s) without deviation.

# CONTENTS

<b>DOCUMENT REVISION HISTORY .....</b>	<b>4</b>
<b>1. GENERAL INFORMATION .....</b>	<b>5</b>
<b>1.1 GENERAL DESCRIPTION OF EQUIPMENT UNDER TEST.....</b>	<b>5</b>
<b>1.2 ACCESSORY INFORMATION .....</b>	<b>5</b>
<b>1.3 ANTENNA INFORMATION DETAIL<sup>▲</sup> .....</b>	<b>5</b>
<b>1.4 EQUIPMENT MODIFICATIONS.....</b>	<b>5</b>
<b>2. SUMMARY OF TEST RESULTS .....</b>	<b>6</b>
<b>3. DESCRIPTION OF TEST CONFIGURATION .....</b>	<b>7</b>
<b>3.1 OPERATION FREQUENCY DETAIL .....</b>	<b>7</b>
<b>3.2 EUT OPERATION CONDITION .....</b>	<b>7</b>
<b>3.3 SUPPORT EQUIPMENT LIST AND DETAILS.....</b>	<b>7</b>
<b>3.4 SUPPORT CABLE LIST AND DETAILS.....</b>	<b>7</b>
<b>3.5 BLOCK DIAGRAM OF TEST SETUP.....</b>	<b>8</b>
<b>3.6 TEST FACILITY .....</b>	<b>9</b>
<b>3.7 MEASUREMENT UNCERTAINTY .....</b>	<b>9</b>
<b>4. REQUIREMENTS AND TEST PROCEDURES .....</b>	<b>10</b>
<b>4.1 AC LINE CONDUCTED EMISSIONS .....</b>	<b>10</b>
4.1.1 Applicable Standard.....	10
4.1.2 EUT Setup.....	11
4.1.3 EMI Test Receiver Setup .....	11
4.1.4 Test Procedure.....	12
4.1.5 Corrected Amplitude & Margin Calculation.....	12
4.1.6 Test Result.....	12
<b>4.2 RADIATED SPURIOUS EMISSIONS .....</b>	<b>13</b>
4.2.1 Applicable Standard.....	13
4.2.2 EUT Setup.....	13
4.2.3 EMI Test Receiver & Spectrum Analyzer Setup.....	15
4.2.4 Test Procedure.....	15
4.2.5 Corrected Result & Margin Calculation.....	15
4.2.6 Test Result.....	15
<b>4.3 20 DB EMISSION BANDWIDTH.....</b>	<b>16</b>
4.3.1 Applicable Standard.....	16
4.3.2 EUT Setup.....	16
4.3.3 Test Procedure.....	16
4.3.4 Test Result.....	17
<b>4.4 CHANNEL SEPARATION.....</b>	<b>18</b>
4.4.1 Applicable Standard.....	18
4.4.2 EUT Setup.....	18
4.4.3 Test Procedure.....	18
4.4.4 Test Result.....	18
<b>4.5 NUMBER OF HOPPING FREQUENCY .....</b>	<b>19</b>

4.5.1 Applicable Standard ..... 19

4.5.2 EUT Setup..... 19

4.5.3 Test Procedure..... 19

4.5.4 Test Result..... 19

**4.6 TIME OF OCCUPANCY (DWELL TIME) .....20**

4.6.1 Applicable Standard..... 20

4.6.2 EUT Setup..... 20

4.6.3 Test Procedure..... 20

4.6.4 Test Result..... 21

**4.7 MAXIMUM CONDUCTED OUTPUT POWER .....22**

4.7.1 Applicable Standard..... 22

4.7.2 EUT Setup..... 22

4.7.3 Test Procedure..... 22

4.7.4 Test Result..... 22

**4.8 100 KHZ BANDWIDTH OF FREQUENCY BAND EDGE .....23**

4.8.1 Applicable Standard..... 23

4.8.2 EUT Setup..... 23

4.8.3 Test Procedure..... 23

4.8.4 Test Result..... 24

**4.9 ANTENNA REQUIREMENT .....25**

4.9.1 Applicable Standard..... 25

4.9.2 Judgment ..... 25

**5. TEST DATA AND RESULTS .....26**

**5.1 AC LINE CONDUCTED EMISSIONS .....26**

**5.2 RADIATED SPURIOUS EMISSIONS .....31**

**5.3 20 dB EMISSION BANDWIDTH.....42**

**5.4 CHANNEL SEPARATION.....45**

**5.5 NUMBER OF HOPPING FREQUENCY .....47**

**5.6 TIME OF OCCUPANCY (DWELL TIME) .....48**

**5.7 MAXIMUM CONDUCTED OUTPUT POWER .....51**

**5.8 100 KHZ BANDWIDTH OF FREQUENCY BAND EDGE .....54**

**EXHIBIT A - EUT PHOTOGRAPHS .....57**

**EXHIBIT B - TEST SETUP PHOTOGRAPHS .....58**

**EXHIBIT C - RF EXPOSURE EVALUATION.....59**

**APPLICABLE STANDARD .....59**

**MEASUREMENT RESULT .....59**

---

## DOCUMENT REVISION HISTORY

---

Revision Number	Report Number	Description of Revision	Date of Revision
1.0	2502T01066E-RF-00A	Original Report	2025/6/16

# 1. GENERAL INFORMATION

## 1.1 General Description of Equipment under Test

<b>EUT Name:</b>	Phone
<b>EUT Model:</b>	NEO N3
<b>Operation Frequency:</b>	2402-2480MHz
<b>Maximum Peak Output Power (Conducted):</b>	3.17dBm
<b>Modulation Type:</b>	GFSK, $\pi/4$ -DQPSK, 8DPSK
<b>Rated Input Voltage:</b>	DC 3.7V from battery or DC 5V from adapter
<b>Serial Number:</b>	339M-1(for RF Conducted Test) 339M-2(for Emissions Test)
<b>EUT Received Date:</b>	2025/5/20
<b>EUT Received Status:</b>	Good

## 1.2 Accessory Information

Accessory Description	Manufacturer	Model	Parameters
Adapter	Maxwest	NEO N3	<b>Input:</b> AC 100-240V 50/60Hz 0.3A <b>Output:</b> DC 5V/500mA
Earphone	Maxwest	/	Unshielded without Ferrite Core, 1m

## 1.3 Antenna Information Detail<sup>^</sup>

Antenna Type	Input Impedance (Ohm)	Frequency Range (MHz)	Antenna Gain (dBi)
Wire Antenna	50	2400-2500	-1.51
<b>The design of compliance with §15.203:</b>			
<input checked="" type="checkbox"/>	Unit uses a permanently attached antenna.		
<input type="checkbox"/>	Unit uses a unique coupling to the intentional radiator.		
<input type="checkbox"/>	Unit was professionally installed, and installer shall be responsible for verifying that the correct antenna is employed with the unit.		

## 1.4 Equipment Modifications

No modifications are made to the EUT during all test items.

## 2. SUMMARY OF TEST RESULTS

FCC Rules	Description of Test	Result
FCC §15.207(a)	AC Line Conducted Emissions	Compliant
FCC §15.205, §15.209, §15.247(d)	Radiated Spurious Emissions	Compliant
FCC §15.247(a)(1)	20 dB Emission Bandwidth	Compliant
FCC §15.247(a)(1)	Channel Separation	Compliant
FCC §15.247(a)(1)(iii)	Number of Hopping Frequency	Compliant
FCC §15.247(a)(1)(iii)	Time of Occupancy (Dwell Time)	Compliant
FCC §15.247(b)(1)	Maximum Conducted Output Power	Compliant
FCC §15.247(d)	100 kHz Bandwidth of Frequency Band Edge	Compliant
FCC §15.203	Antenna Requirement	Compliant
FCC §15.247(i), §1.1310	RF Exposure Evaluation	Compliant

Note 1: For AC line conducted emissions, the maximum output power mode and channel was tested.

Note 2: For Radiated Spurious Emissions 9kHz~ 1GHz and 18GHz~25GHz, the maximum output power mode and channel was tested.

### 3. DESCRIPTION OF TEST CONFIGURATION

#### 3.1 Operation Frequency Detail

Channel	Frequency (MHz)	Channel	Frequency (MHz)
0	<b>2402</b>	40	2442
1	2403	41	2443
...	...	...	...
...	...	...	...
...	...	78	<b>2480</b>
39	<b>2441</b>	/	/

Note: The above frequencies in bold were performed the test.

#### 3.2 EUT Operation Condition

The EUT was configured for testing in Engineering Mode, which was provided by the manufacturer. The EUT configuration as below:

<b>EUT Exercise Software:</b>	Wideband Radio Communication Tester		
The software was provided by manufacturer. The maximum power was configured as below, that was provided by the manufacturer ▲:			
Test Modes	Power Level Setting		
	Lowest Channel	Middle Channel	Highest Channel
GFSK	Default	Default	Default
$\pi/4$ -DQPSK	Default	Default	Default
8DPSK	Default	Default	Default

#### 3.3 Support Equipment List and Details

Manufacturer	Description	Model	Serial Number
Maxwest	Adapter	NEO N3	Unknown
Maxwest	Earphone	Unknown	Unknown
SanDisk	TF Card	UHS-I-16G	9292DVDSV0XZ
R&S	Wideband Radio Communication Tester	CMW500	149216
TEJIATE	Antenna	SMA	Unknown

#### 3.4 Support Cable List and Details

Cable Description	Shielding Type	Ferrite Core	Length (m)	From Port	To
Power Cable	No	No	1	Adapter	EUT
Earphone Cable	No	No	1	Earphone	EUT
Antenna Cable	No	No	10	Antenna	CMW500

### 3.5 Block Diagram of Test Setup

for AC Line Conducted Emissions:

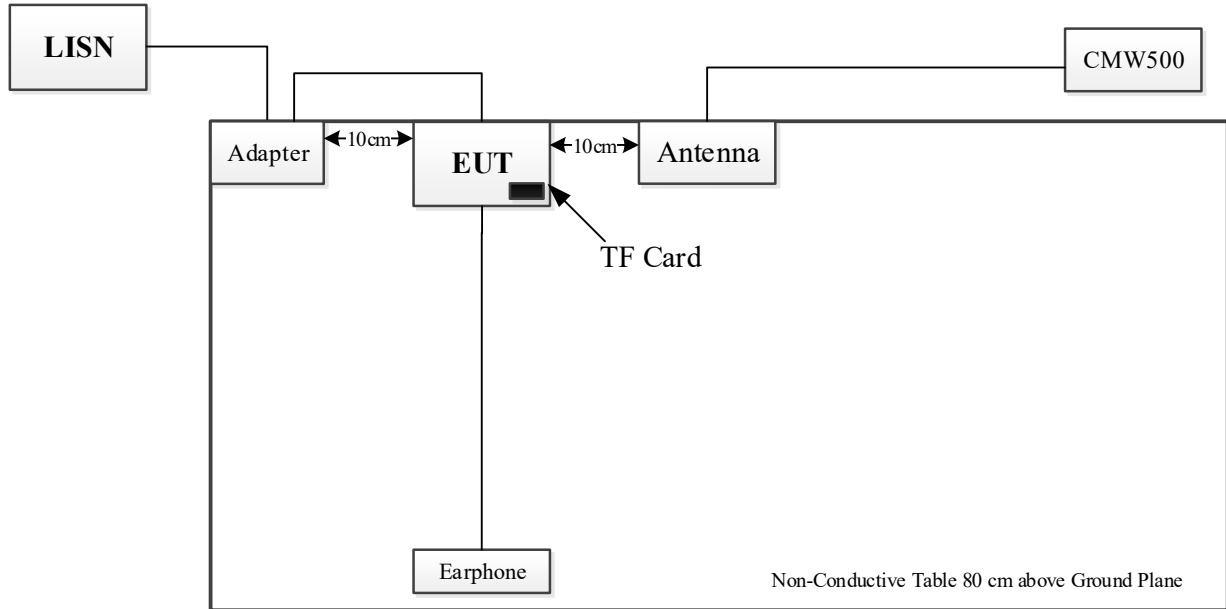

for Radiated Spurious Emissions Below 1GHz:

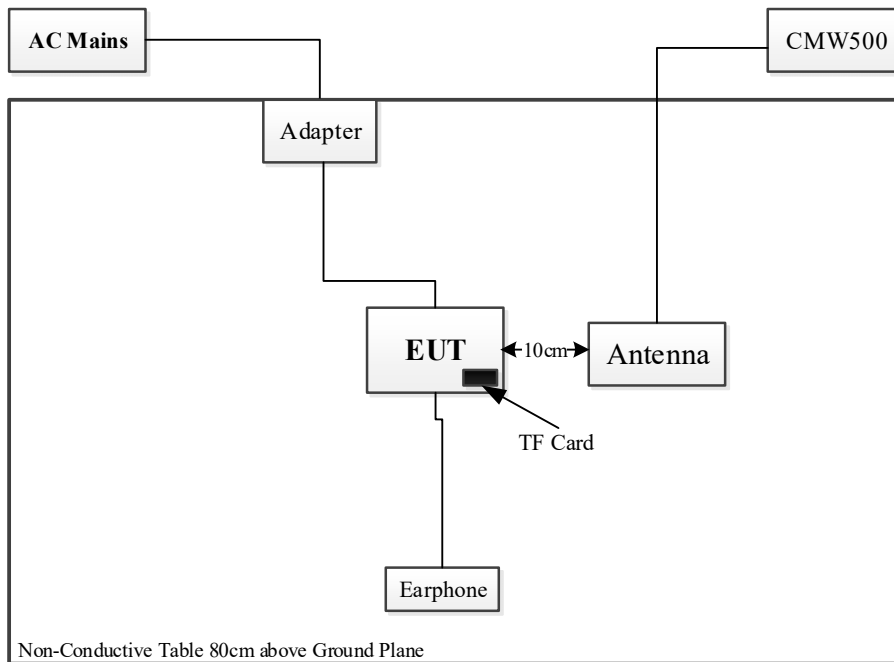



**for Radiated Spurious Emissions Above 1GHz:**

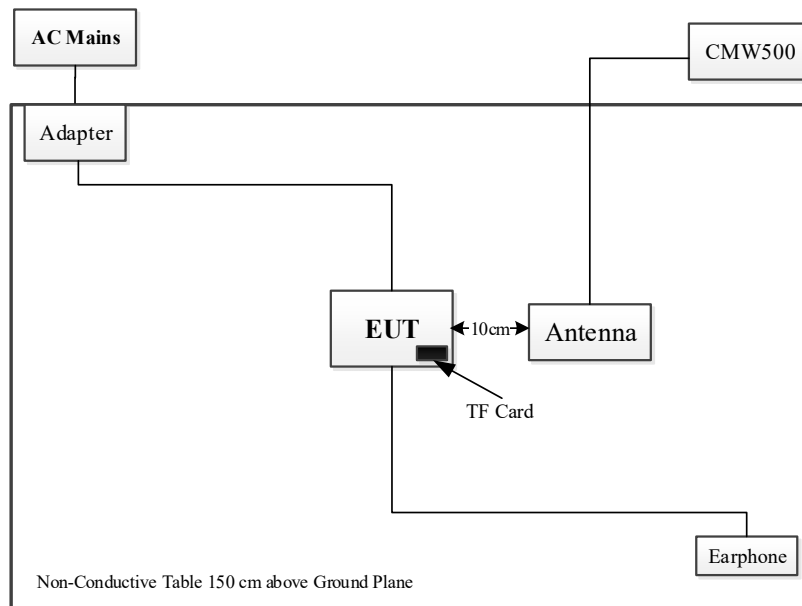

**3.6 Test Facility**

The Test site used by Bay Area Compliance Laboratories Corp. (Dongguan) to collect test data is located on the No.12, Pulong East 1st Road, Tangxia Town, Dongguan, Guangdong, China.

The lab has been recognized as the FCC accredited lab under the KDB 974614 D01 and is listed in the FCC Public Access Link (PAL) database, FCC Registration No. : 829273, the FCC Designation No. : CN5044.

The lab has been recognized by Innovation, Science and Economic Development Canada to test to Canadian radio equipment requirements, the CAB identifier: CN0022.

**3.7 Measurement Uncertainty**

Otherwise required by the applicant or Product Regulations, Decision Rule in this report did not consider the uncertainty. The extended uncertainty given in this report is obtained by combining the standard uncertainty times the coverage factor K with the 95% confidence interval.

Parameter	Measurement Uncertainty
Occupied Channel Bandwidth	±5 %
RF output power, conducted	±0.61 dB
Power Spectral Density, conducted	±0.61 dB
Unwanted Emissions, radiated	9kHz~30MHz: 3.3dB, 30MHz~200MHz: 4.55 dB, 200MHz~1GHz: 5.92 dB, 1GHz~6GHz: 4.98 dB, 6GHz~18GHz: 5.89 dB, 18GHz~26.5GHz:5.47 dB, 26.5GHz~40GHz:5.63 dB
Unwanted Emissions, conducted	±2.47 dB
Temperature	±1 °C
Humidity	±5%
DC and low frequency voltages	±0.4%
Duty Cycle	1%
AC Power Lines Conducted Emission	3.11 dB (150 kHz to 30 MHz)

## 4. REQUIREMENTS AND TEST PROCEDURES

### 4.1 AC Line Conducted Emissions

#### 4.1.1 Applicable Standard

FCC§15.207(a).

(a) Except as shown in paragraphs (b) and (c) of this section, for an intentional radiator that is designed to be connected to the public utility (AC) power line, the radio frequency voltage that is conducted back onto the AC power line on any frequency or frequencies, within the band 150 kHz to 30 MHz, shall not exceed the limits in the following table, as measured using a 50 μH/50 ohms line impedance stabilization network (LISN). Compliance with the provisions of this paragraph shall be based on the measurement of the radio frequency voltage between each power line and ground at the power terminal. The lower limit applies at the boundary between the frequency ranges.

Frequency of emission (MHz)	Conducted limit (dBμV)	
	Quasi-peak	Average
0.15-0.5	66 to 56*	56 to 46*
0.5-5	56	46
5-30	60	50

\*Decreases with the logarithm of the frequency.

(b) The limit shown in paragraph (a) of this section shall not apply to carrier current systems operating as intentional radiators on frequencies below 30 MHz. In lieu thereof, these carrier current systems shall be subject to the following standards:

(1) For carrier current system containing their fundamental emission within the frequency band 535-1705 kHz and intended to be received using a standard AM broadcast receiver: no limit on conducted emissions.

(2) For all other carrier current systems: 1000 μV within the frequency band 535-1705 kHz, as measured using a 50 μH/50 ohms LISN.

(3) Carrier current systems operating below 30 MHz are also subject to the radiated emission limits in §15.205, §15.209, §15.221, §15.223, or §15.227, as appropriate.

(c) Measurements to demonstrate compliance with the conducted limits are not required for devices which only employ battery power for operation and which do not operate from the AC power lines or contain provisions for operation while connected to the AC power lines. Devices that include, or make provisions for, the use of battery chargers which permit operating while charging, AC adapters or battery eliminators or that connect to the AC power lines indirectly, obtaining their power through another device which is connected to the AC power lines, shall be tested to demonstrate compliance with the conducted limits.

**4.1.2 EUT Setup**

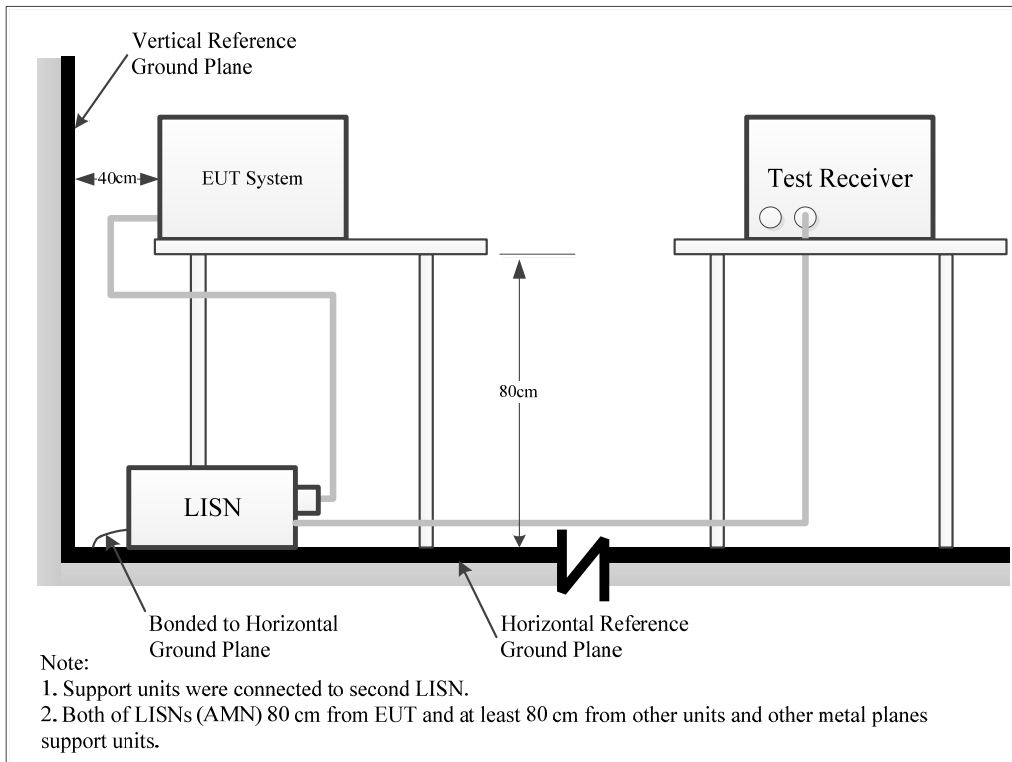

The setup of EUT is according with per ANSI C63.10-2020 measurement procedure. The specification used was with the FCC Part 15.207 limits.

The spacing between the peripherals was 10 cm.

The adapter or EUT was connected to the main LISN with a 120 V/60 Hz AC power source.

**4.1.3 EMI Test Receiver Setup**

The EMI test receiver was set to investigate the spectrum from 150 kHz to 30 MHz.

During the conducted emission test, the EMI test receiver was set with the following configurations:

Frequency Range	IF B/W
150 kHz – 30 MHz	9 kHz

#### 4.1.4 Test Procedure

The frequency and amplitude of the six highest ac power-line conducted emissions relative to the limit, measured over all the current-carrying conductors of the EUT power cords, and the operating frequency or frequency to which the EUT is tuned (if appropriate), should be reported, unless such emissions are more than 20 dB below the limit. AC power-line conducted emissions measurements are to be separately carried out only on each of the phase (“hot”) line(s) and (if used) on the neutral line(s), but not on the ground [protective earth] line(s). If less than six emission frequencies are within 20 dB of the limit, then the noise level of the measuring instrument at representative frequencies should be reported. The specific conductor of the power-line cord for each of the reported emissions should be identified. Measure the six highest emissions with respect to the limit on each current-carrying conductor of each power cord associated with the EUT (but not the power cords of associated or peripheral equipment that are part of the test configuration). Then, report the six highest emissions with respect to the limit from among all the measurements identifying the frequency and specific current-carrying conductor identified with the emission. The six highest emissions should be reported for each of the current-carrying conductors, or the six highest emissions may be reported over all the current-carrying conductors.

#### 4.1.5 Corrected Amplitude & Margin Calculation

The basic equation is as follows:

Result = Reading + Factor

Factor = attenuation caused by cable loss + voltage division factor of AMN

The “**Margin**” column of the following data tables indicates the degree of compliance within the applicable limit. The equation for margin calculation is as follows:

Margin = Limit – Result

#### 4.1.6 Test Result

Please refer to section 5.1.

## 4.2 Radiated Spurious Emissions

### 4.2.1 Applicable Standard

FCC §15.247 (d);

In any 100 kHz bandwidth outside the frequency band in which the spread spectrum or digitally modulated intentional radiator is operating, the radio frequency power that is produced by the intentional radiator shall be at least 20 dB below that in the 100 kHz bandwidth within the band that contains the highest level of the desired power, based on either an RF conducted or a radiated measurement, provided the transmitter demonstrates compliance with the peak conducted power limits. If the transmitter complies with the conducted power limits based on the use of RMS averaging over a time interval, as permitted under paragraph (b)(3) of this section, the attenuation required under this paragraph shall be 30 dB instead of 20 dB. Attenuation below the general limits specified in §15.209(a) is not required. In addition, radiated emissions which fall in the restricted bands, as defined in §15.205(a), must also comply with the radiated emission limits specified in §15.209(a) (see §15.205(c)).

### 4.2.2 EUT Setup

9kHz~30MHz:

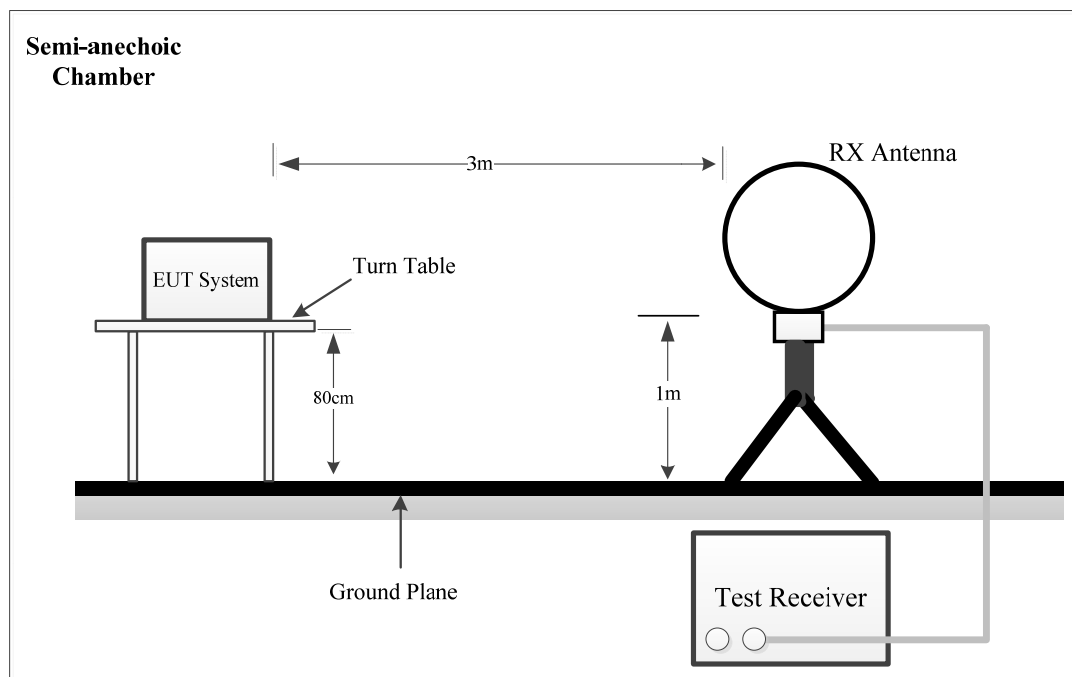

**30MHz~1GHz:**

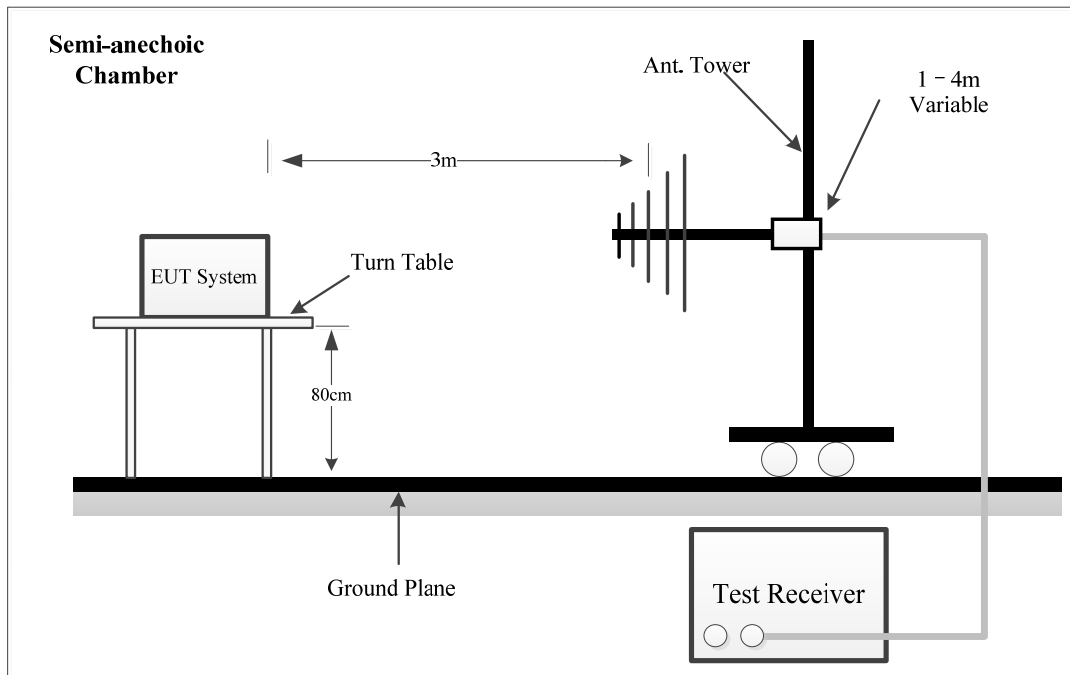

**Above 1GHz:**

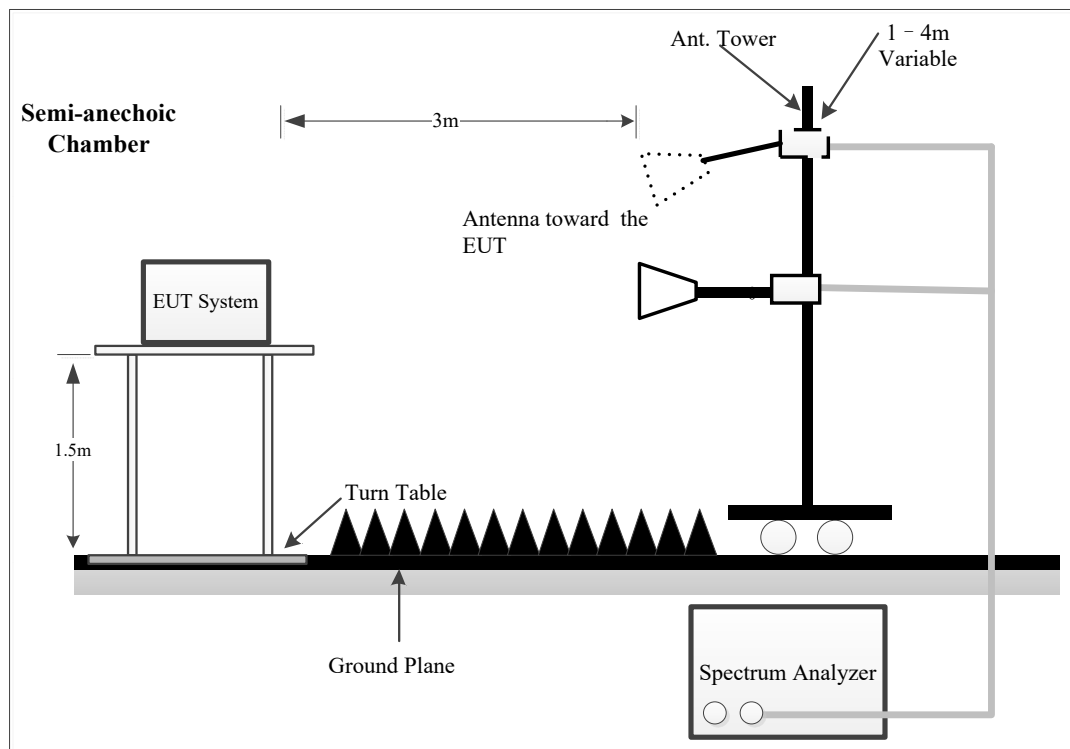

The radiated emissions were performed in the 3 meters distance, using the setup accordance with the ANSI C63.10-2020. The specification used was the FCC 15.209, and FCC 15.247 limits.

The external I/O cables were draped along the test table and formed a bundle 30 to 40 cm long in the middle.

The spacing between the peripherals was 10 cm.

For 9kHz-30MHz test, the lowest height of the magnetic antenna shall be 1 m above the ground and three antenna orientations (parallel, perpendicular, and ground-parallel) shall be measured.

**4.2.3 EMI Test Receiver & Spectrum Analyzer Setup**

During the radiated emission test, the EMI test receiver & Spectrum Analyzer Setup were set with the following configurations:

9kHz-1000MHz:

Frequency Range	Measurement	RBW	Video B/W	IF B/W	Detector
9 kHz – 150 kHz	QP/AV	300 Hz	1 kHz	200 Hz	QP/AV
150 kHz – 30 MHz	QP/AV	10 kHz	30 kHz	9 kHz	QP/AV
30 MHz – 1000 MHz	PK	100 kHz	300 kHz	/	PK
	QP	/	/	120 kHz	QP

1GHz- 25GHz:

Pre-scan:

Measurement	RBW	Video B/W	Detector
PK	1MHz	3 MHz	PK
Ave.	1MHz	5kHz	PK

Final measurement for emission identified during the pre-scan:

Measurement	RBW	Video B/W	Detector
PK	1MHz	3 MHz	PK
Ave.	1MHz	10 Hz	PK

**4.2.4 Test Procedure**

Maximizing procedure was performed on the highest emissions to ensure that the EUT complied with all installation combinations.

Data was recorded in Quasi-peak detection mode for frequency range of 9 kHz-1 GHz except 9-90 kHz, 110-490 kHz, employing an average detector, peak and Average detection modes for frequencies above 1 GHz.

If the maximized peak measured value complies with under the QP/Average limit more than 6dB, then it is unnecessary to perform an QP/Average measurement.

All emissions under the average limit and under the noise floor have not recorded in the report.

**4.2.5 Corrected Result & Margin Calculation**

The basic equation is as follows:

Result = Reading + Factor

Factor = Antenna Factor + Cable Loss- Amplifier Gain

The “Margin” column of the following data tables indicates the degree of compliance within the applicable limit. The equation for margin calculation is as follows:

Margin = Limit – Result

**4.2.6 Test Result**

Please refer to section 5.2.

### 4.3 20 dB Emission Bandwidth

#### 4.3.1 Applicable Standard

FCC §15.247 (a)(1)

Frequency hopping systems shall have hopping channel carrier frequencies separated by a minimum of 25 kHz or the 20 dB bandwidth of the hopping channel, whichever is greater. Alternatively, frequency hopping systems operating in the 2400-2483.5 MHz band may have hopping channel carrier frequencies that are separated by 25 kHz or two-thirds of the 20 dB bandwidth of the hopping channel, whichever is greater, provided the systems operate with an output power no greater than 125 mW. The system shall hop to channel frequencies that are selected at the system hopping rate from a pseudo randomly ordered list of hopping frequencies. Each frequency must be used equally on the average by each transmitter. The system receivers shall have input bandwidths that match the hopping channel bandwidths of their corresponding transmitters and shall shift frequencies in synchronization with the transmitted signals.

#### 4.3.2 EUT Setup

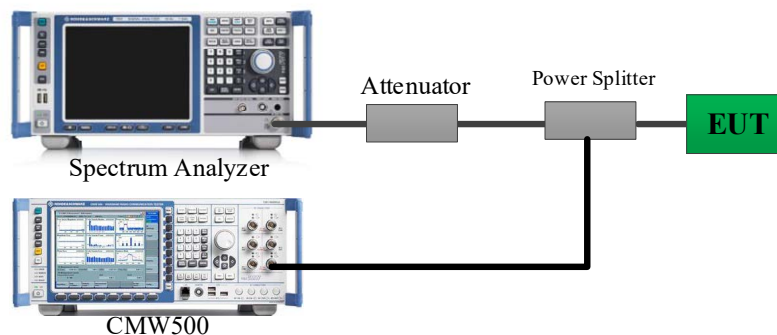

Note: The Insertion loss of the RF cable and Power Splitter was offset into the Reading of Spectrum Analyzer.

#### 4.3.3 Test Procedure

According to ANSI C63.10-2020 Section 6.9.2

- The spectrum analyzer center frequency is set to the nominal EUT channel center frequency. The span range for the EMI receiver or spectrum analyzer shall be between two times and five times the OBW.
- The nominal IF filter bandwidth (3 dB RBW) shall be in the range of 1% to 5% of the OBW and video bandwidth (VBW) shall be approximately three times RBW, unless otherwise specified by the applicable requirement.
- Set the reference level of the instrument as required, keeping the signal from exceeding the maximum input mixer level for linear operation. In general, the peak of the spectral envelope shall be more than  $[10 \log (\text{OBW}/\text{RBW})]$  below the reference level. Specific guidance is given in 4.1.6.2
- Steps a) through c) might require iteration to adjust within the specified tolerances.
- The dynamic range of the instrument at the selected RBW shall be more than 10 dB below the target “-xx dB down” requirement; that is, if the requirement calls for measuring the -20 dB OBW, the instrument noise floor at the selected RBW shall be at least 30 dB below the reference value.
- Set detection mode to peak and trace mode to max hold.
- Determine the reference value: Set the EUT to transmit an unmodulated carrier or modulated signal, as applicable. Allow the trace to stabilize. Set the spectrum analyzer marker to the highest level of the displayed



trace (this is the reference value).

- h) Determine the “-xx dB down amplitude” using [(reference value) - xx]. Alternatively, this calculation may be made by using the marker-delta function of the instrument.
- i) If the reference value is determined by an unmodulated carrier, then turn the EUT modulation ON, and either clear the existing trace or start a new trace on the spectrum analyzer and allow the new trace to stabilize. Otherwise, the trace from step g) shall be used for step j).
- j) Place two markers, one at the lowest frequency and the other at the highest frequency of the envelope of the spectral display, such that each marker is at or slightly below the “-xx dB down amplitude” determined in step h). If a marker is below this “-xx dB down amplitude” value, then it shall be as close as possible to this value. The occupied bandwidth is the frequency difference between the two markers. Alternatively, set a marker at the lowest frequency of the envelope of the spectral display, such that the marker is at or slightly below the “-xx dB down amplitude” determined in step h). Reset the marker-delta function and move the marker to the other side of the emission until the delta marker amplitude is at the same level as the reference marker amplitude. The marker-delta frequency reading at this point is the specified emission bandwidth.
- k) The occupied bandwidth shall be reported by providing plot(s) of the measuring instrument display; the plot axes and the scale units per division shall be clearly labeled. Tabular data may be reported in addition to the plot(s).

#### 4.3.4 Test Result

Please refer to section 5.3.

## 4.4 Channel Separation

### 4.4.1 Applicable Standard

FCC §15.247 (a)(1)

Frequency hopping systems shall have hopping channel carrier frequencies separated by a minimum of 25 kHz or the 20 dB bandwidth of the hopping channel, whichever is greater. Alternatively, frequency hopping systems operating in the 2400-2483.5 MHz band may have hopping channel carrier frequencies that are separated by 25 kHz or two-thirds of the 20 dB bandwidth of the hopping channel, whichever is greater, provided the systems operate with an output power no greater than 125 mW. The system shall hop to channel frequencies that are selected at the system hopping rate from a pseudo randomly ordered list of hopping frequencies. Each frequency must be used equally on the average by each transmitter. The system receivers shall have input bandwidths that match the hopping channel bandwidths of their corresponding transmitters and shall shift frequencies in synchronization with the transmitted signals.

### 4.4.2 EUT Setup

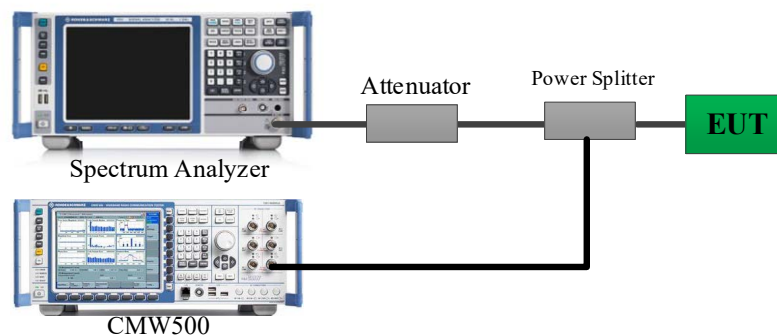

Note: The Insertion loss of the RF cable and Power Splitter was offset into the Reading of Spectrum Analyzer.

### 4.4.3 Test Procedure

According to ANSI C63.10-2020 Section 7.8.2

The EUT shall have its hopping function enabled. Use the following spectrum analyzer settings:

- Span: Wide enough to capture the peaks of two adjacent channels.
- RBW: Start with the RBW set to approximately 30% of the channel spacing; adjust as necessary to best identify the center of each individual channel.
- Video (or average) bandwidth (VBW)  $\geq$  RBW.
- Sweep: No faster than coupled (auto) time.
- Detector function: Peak.
- Trace: Max hold.
- Allow the trace to stabilize.

Use the marker-delta function to determine the separation between the peaks of the adjacent channels. Compliance of an EUT with the appropriate regulatory limit shall be determined. A plot of the data shall be included in the test report.

### 4.4.4 Test Result

Please refer to section 5.4.

## 4.5 Number of Hopping Frequency

### 4.5.1 Applicable Standard

FCC §15.247 (a)(1)(iii)

Frequency hopping systems in the 2400–2483.5 MHz band shall use at least 15 channels. The average time of occupancy on any channel shall not be greater than 0.4 seconds within a period of 0.4 seconds multiplied by the number of hopping channels employed. Frequency hopping systems may avoid or suppress transmissions on a particular hopping frequency provided that a minimum of 15 channels are used.

### 4.5.2 EUT Setup

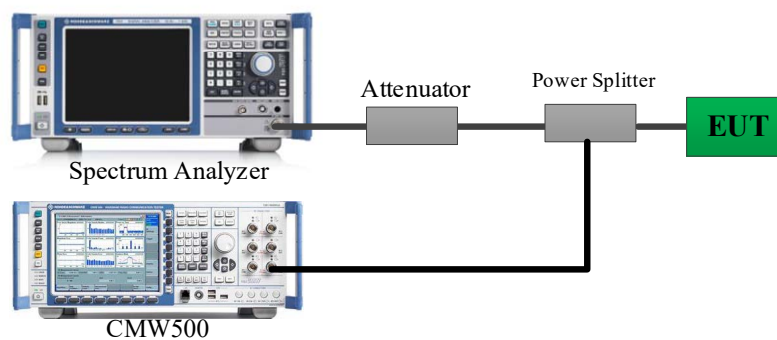

Note: The Insertion loss of the RF cable and Power Splitter was offset into the Reading of Spectrum Analyzer.

### 4.5.3 Test Procedure

According to ANSI C63.10-2020 Section 7.8.3

The EUT shall have its hopping function enabled. Use the following spectrum analyzer settings:

- Span: The frequency band of operation. Depending on the number of channels the device supports, it may be necessary to divide the frequency range of operation across multiple spans, to allow the individual channels to be clearly seen.
- RBW: To identify clearly the individual channels, set the RBW to less than 30% of the channel spacing or the 20 dB bandwidth, whichever is smaller.
- VBW  $\geq$  RBW.
- Sweep: No faster than coupled (auto) time.
- Detector function: Peak.
- Trace: Max hold.
- Allow the trace to stabilize

It might prove necessary to break the span up into subranges to show clearly all of the hopping frequencies. Compliance of an EUT with the appropriate regulatory limit shall be determined for the number of hopping channels. A spectral plot of the data shall be included in the test report.

### 4.5.4 Test Result

Please refer to section 5.5.

## 4.6 Time of Occupancy (Dwell Time)

### 4.6.1 Applicable Standard

Frequency hopping systems in the 2400-2483.5 MHz shall use at least 15 channels. The average time of occupancy on any channel shall not be greater than 0.4 seconds within a period of 0.4 seconds multiplied by the number of hopping channels employed. Frequency hopping systems may avoid or suppress transmissions on a particular hopping frequency provided that a minimum of 15 channels are used.

### 4.6.2 EUT Setup

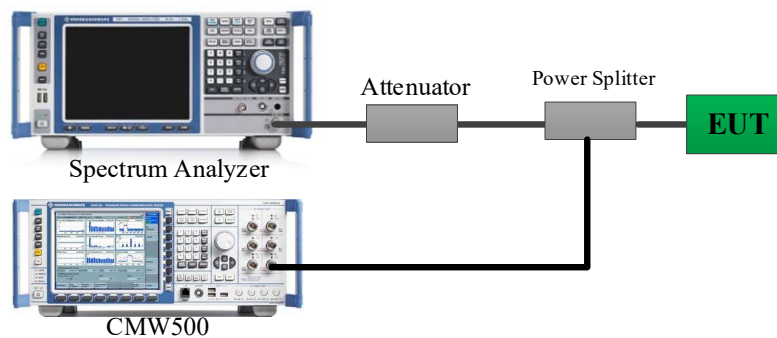

Note: The Insertion loss of the RF cable and Power Splitter was offset into the Reading of Spectrum Analyzer.

### 4.6.3 Test Procedure

According to ANSI C63.10-2020 Section 7.8.4

The EUT shall have its hopping function enabled. Use the following spectrum analyzer settings:

- Span: Zero span, centered on a hopping channel.
- RBW shall be  $\leq$  channel spacing and where possible RBW should be set  $\gg 1 / T$ , where T is the expected transmission time per hop.
- Sweep time: Set so that the start of the first transmission and end of the last transmission for the hop are clearly captured. Setting the sweep time to be slightly longer than the hopping period per channel (hopping period =  $1/\text{hopping rate}$ ) should achieve this.
- Use a video trigger, where possible with a trigger delay, so that the start of the transmission is clearly observed. The trigger level might need adjustment to reduce the chance of triggering when the system hops on an adjacent channel.
- Detector function: Peak.
- Trace: Clear-write, single sweep.
- Place markers at the start of the first transmission on the channel and at the end of the last transmission. The dwell time per hop is the time between these two markers.

To determine the number of hops on a channel in the regulatory observation period repeat the measurement using a longer sweep time. When the device uses a single hopping sequence the period of measurement should be sufficient to capture at least 2 hops. When the device uses a dynamic hopping sequence, or the sequence varies, the period of measurement may need to capture multiple hops to better determine the average time of occupancy. Count the number of hops on the channel across the sweep time.

The average number of hops on the same channel within the regulatory observation period is calculated from the number of hops on the channel divided by the spectrum analyzer sweep time multiplied by the regulatory observation period. For example, if three hops are counted with an analyzer sweep time of 500 ms and the regulatory observation period is 10 s, then the number of hops in that ten seconds is  $3 / 0.5 \times 10$ , or 60 hops.

The average time of occupancy is calculated by multiplying the dwell time per hop by the number of hops in the observation period.

Where the device shares the same hopping algorithms (dwell time, channel selection) across multiple data rates or modulation schemes then the time of occupancy need only be measured for one of those modulation schemes or data rates. If the dwell time value varies with different modes of operation (data rate, modulation format, number of hopping channels, etc.), then repeat this test for each variation in dwell time.

Spectral plots of the channel occupancy shall be included in the report.

#### **4.6.4 Test Result**

Please refer to section 5.6.

## 4.7 Maximum Conducted Output Power

### 4.7.1 Applicable Standard

FCC §15.247 (b)(1)

For frequency hopping systems operating in the 2400–2483.5 MHz band employing at least 75 non-overlapping hopping channels, and all frequency hopping systems in the 5725-5850 MHz band: 1 watt. For all other frequency hopping systems in the 2400–2483.5 MHz band: 0.125 watts

### 4.7.2 EUT Setup

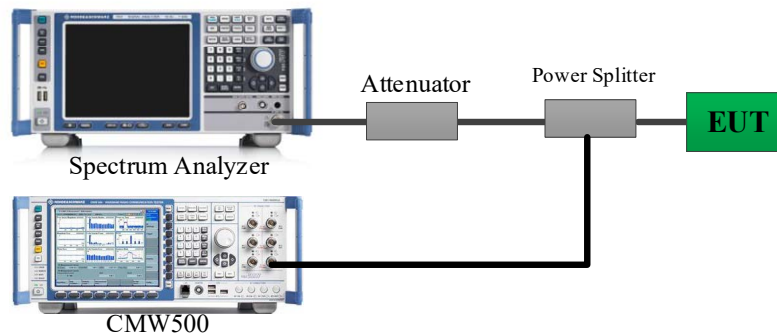

Note: The Insertion loss of the RF cable and Power Splitter was offset into the Reading of Spectrum Analyzer.

### 4.7.3 Test Procedure

According to ANSI C63.10-2020 Section 7.8.5

This is an RF-conducted test to evaluate maximum peak output power. Use a direct connection between the antenna port of the unlicensed wireless device and the spectrum analyzer, through suitable attenuation. Frequency hopping shall be disabled for this test. Use the following spectrum analyzer settings:

- Span: Approximately five times the 20 dB bandwidth, centered on a hopping channel.
- RBW > 20 dB bandwidth of the emission being measured.
- VBW  $\geq$  RBW.
- Sweep: No faster than coupled (auto) time.
- Detector function: Peak.
- Trace: Max-hold.
- Allow trace to stabilize.
- Use the marker-to-peak function to set the marker to the peak of the emission.
- The indicated level is the peak output power, after any corrections for external attenuators and cables.
- A spectral plot of the test results and setup description shall be included in the test report.

NOTE—A peak responding power meter may be used, where the power meter and sensor system video bandwidth is greater than the occupied bandwidth of the unlicensed wireless device, rather than a spectrum analyzer.

### 4.7.4 Test Result

Please refer to section 5.7.

## 4.8 100 kHz Bandwidth of Frequency Band Edge

### 4.8.1 Applicable Standard

FCC §15.247 (d);

In any 100 kHz bandwidth outside the frequency band in which the spread spectrum or digitally modulated intentional radiator is operating, the radio frequency power that is produced by the intentional radiator shall be at least 20 dB below that in the 100 kHz bandwidth within the band that contains the highest level of the desired power, based on either an RF conducted or a radiated measurement, provided the transmitter demonstrates compliance with the peak conducted power limits. If the transmitter complies with the conducted power limits based on the use of RMS averaging over a time interval, as permitted under paragraph (b)(3) of this section, the attenuation required under this paragraph shall be 30 dB instead of 20 dB. Attenuation below the general limits specified in §15.209(a) is not required. In addition, radiated emissions which fall in the restricted bands, as defined in §15.205(a), must also comply with the radiated emission limits specified in §15.209(a) (see §15.205(c)).

### 4.8.2 EUT Setup

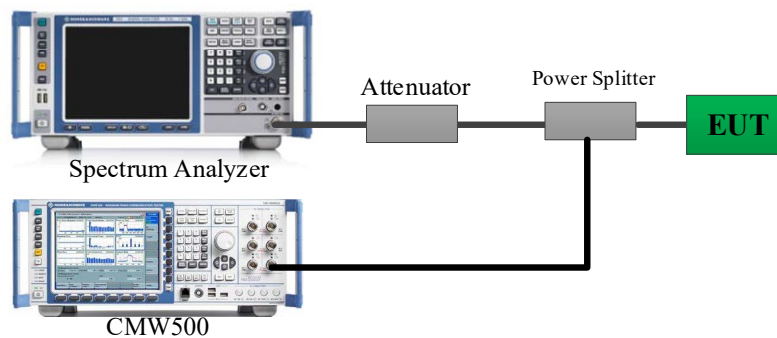

Note: The Insertion loss of the RF cable and Power Splitter was offset into the Reading of Spectrum Analyzer.

### 4.8.3 Test Procedure

According to ANSI C63.10-2020 Section 7.8.7.2

Compliance with a relative limit at the band-edges (e.g., -20 dBc) shall be made on the lowest and on the highest channels with frequency hopping disabled and repeated with frequency hopping enabled. For the latter test the hopping sequence shall include the lowest and highest channels.

For measurements with the hopping disabled the analyzer screen shall clearly show compliance with the requirement within 10 MHz of the allocated band-edge.

For measurements with the hopping enabled the analyzer screen shall clearly show compliance with the requirement within 10 MHz of both of the allocated band-edges. This could require separate spectral plots for each band-edge.

- Set the center frequency and span to encompass frequency range to be measured.
- Set the RBW = 100 kHz.
- Set the VBW  $\geq [3 \times \text{RBW}]$ .
- Detector = peak.
- Sweep time = auto couple.
- Trace mode = max hold.

g) Allow trace to fully stabilize.

h) Use the peak marker function to determine the maximum amplitude level.

Ensure that the amplitude of all unwanted emissions outside of the authorized frequency band (excluding restricted frequency bands) is attenuated by at least the minimum requirements. Report the three highest emissions relative to the limit.

#### **4.8.4 Test Result**

Please refer to section 5.8.



## **4.9 Antenna Requirement**

### **4.9.1 Applicable Standard**

FCC §15.203

An intentional radiator shall be designed to ensure that no antenna other than that furnished by the responsible party shall be used with the device. The use of a permanently attached antenna or of an antenna that uses a unique coupling to the intentional radiator shall be considered sufficient to comply with the provisions of this section. The manufacturer may design the unit so that a broken antenna can be replaced by the user, but the use of a standard antenna jack or electrical connector is prohibited. This requirement does not apply to carrier current devices or to devices operated under the provisions of §§15.211, 15.213, 15.217, 15.219, 15.221, or §15.236. Further, this requirement does not apply to intentional radiators that must be professionally installed, such as perimeter protection systems and some field disturbance sensors, or to other intentional radiators which, in accordance with §15.31(d), must be measured at the installation site. However, the installer shall be responsible for ensuring that the proper antenna is employed so that the limits in this part are not exceeded.

### **4.9.2 Judgment**

**Compliant.** Please refer to the Antenna Information detail in Section 1.3.

## 5. TEST DATA AND RESULTS

### 5.1 AC Line Conducted Emissions

Serial Number:	339M-2	Test Date:	2025/6/11
Test Site:	CE	Test Mode:	Transmitting
Tester:	Yukin Qiu	Test Result:	Pass

#### Environmental Conditions:

Temperature: (°C)	27	Relative Humidity: (%)	60	ATM Pressure: (kPa)	100.5
----------------------	----	---------------------------	----	------------------------	-------

#### Test Equipment List and Details:

Manufacturer	Description	Model	Serial Number	Calibration Date	Calibration Due Date
R&S	LISN	ENV216	101614	2024/9/5	2025/9/4
Unknown	Coaxial Cable	RG 142	C-0200-05	2025/5/6	2026/5/5
R&S	EMI Test Receiver	ESCI	101121	2024/9/5	2025/9/4
Audix	Test Software	E3	191218 V9	N/A	N/A

\* Statement of Traceability: Bay Area Compliance Laboratories Corp. (Dongguan) attests that all calibrations have been performed, traceable to National Primary Standards and International System of Units (SI).

Note: The maximum output power mode and channel: 3DH1(3EDR) mode Highest Channel was tested.

Project No.: 2502T01066E-RF  
 Port: Line  
 Test Mode: Transmitting  
 IF B/W 9kHz PK/AV

Serial No.: 339M-2  
 Tester: Yukin QIU  
 Note:

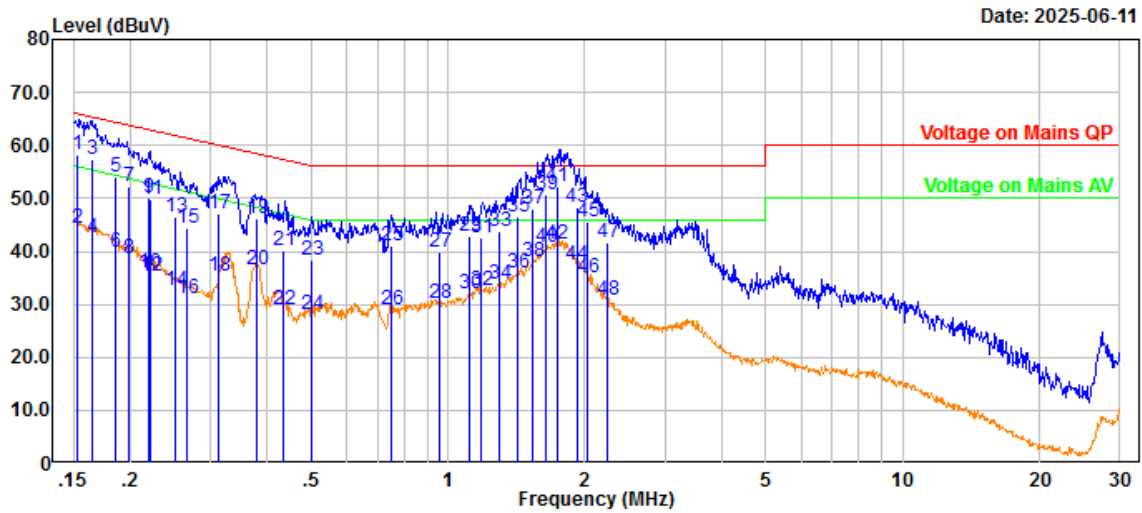

Date: 2025-06-11

No.	Frequency (MHz)	Reading (dBμV)	Factor (dB)	Result (dBμV)	Limit (dBμV)	Margin (dB)	Measurement
1	0.152	47.71	10.70	58.41	65.86	7.45	QP
2	0.152	33.57	10.70	44.27	55.86	11.59	Average
3	0.166	46.65	10.73	57.38	65.18	7.80	QP
4	0.166	31.74	10.73	42.47	55.18	12.71	Average
5	0.186	43.28	10.77	54.05	64.20	10.15	QP
6	0.186	29.18	10.77	39.95	54.20	14.25	Average
7	0.198	41.42	10.80	52.22	63.68	11.46	QP
8	0.198	27.74	10.80	38.54	53.68	15.14	Average
9	0.219	39.44	10.80	50.24	62.85	12.61	QP
10	0.219	25.03	10.80	35.83	52.85	17.02	Average
11	0.222	39.00	10.80	49.80	62.73	12.93	QP
12	0.222	24.59	10.80	35.39	52.73	17.34	Average
13	0.252	35.56	10.80	46.36	61.69	15.33	QP
14	0.252	21.82	10.80	32.62	51.69	19.07	Average
15	0.267	33.66	10.80	44.46	61.20	16.74	QP
16	0.267	20.17	10.80	30.97	51.20	20.23	Average
17	0.314	36.31	10.80	47.11	59.86	12.75	QP
18	0.314	24.58	10.80	35.38	49.86	14.48	Average
19	0.379	35.26	10.81	46.07	58.30	12.23	QP
20	0.379	25.82	10.81	36.63	48.30	11.67	Average
21	0.434	29.36	10.81	40.17	57.17	17.00	QP
22	0.434	18.21	10.81	29.02	47.17	18.15	Average
23	0.501	27.66	10.81	38.47	56.00	17.53	QP
24	0.501	17.42	10.81	28.23	46.00	17.77	Average
25	0.748	30.25	10.81	41.06	56.00	14.94	QP
26	0.748	18.10	10.81	28.91	46.00	17.09	Average
27	0.960	28.93	10.81	39.74	56.00	16.26	QP
28	0.960	19.49	10.81	30.30	46.00	15.70	Average

No.	Frequency (MHz)	Reading (dBµV)	Factor (dB)	Result (dBµV)	Limit (dBµV)	Margin (dB)	Measurement
29	1.113	31.96	10.81	42.77	56.00	13.23	QP
30	1.113	21.17	10.81	31.98	46.00	14.02	Average
31	1.182	31.70	10.81	42.51	56.00	13.49	QP
32	1.182	21.87	10.81	32.68	46.00	13.32	Average
33	1.294	32.89	10.81	43.70	56.00	12.30	QP
34	1.294	23.00	10.81	33.81	46.00	12.19	Average
35	1.427	35.67	10.81	46.48	56.00	9.52	QP
36	1.427	25.27	10.81	36.08	46.00	9.92	Average
37	1.530	37.34	10.81	48.15	56.00	7.85	QP
38	1.530	27.15	10.81	37.96	46.00	8.04	Average
39	1.643	40.03	10.81	50.84	56.00	5.16	QP
40	1.643	29.83	10.81	40.64	46.00	5.36	Average
41	1.734	41.48	10.81	52.29	56.00	3.71	QP
42	1.734	30.57	10.81	41.38	46.00	4.62	Average
43	1.918	37.64	10.81	48.45	56.00	7.55	QP
44	1.918	26.75	10.81	37.56	46.00	8.44	Average
45	2.027	34.75	10.81	45.56	56.00	10.44	QP
46	2.027	24.23	10.81	35.04	46.00	10.96	Average
47	2.237	30.90	10.80	41.70	56.00	14.30	QP
48	2.237	19.86	10.80	30.66	46.00	15.34	Average

Project No.: 2502T01066E-RF  
 Port: neutral  
 Test Mode: Transmitting  
 IF B/W 9kHz PK/AV

Serial No.: 339M-2  
 Tester: Yukin Qiu  
 Note:

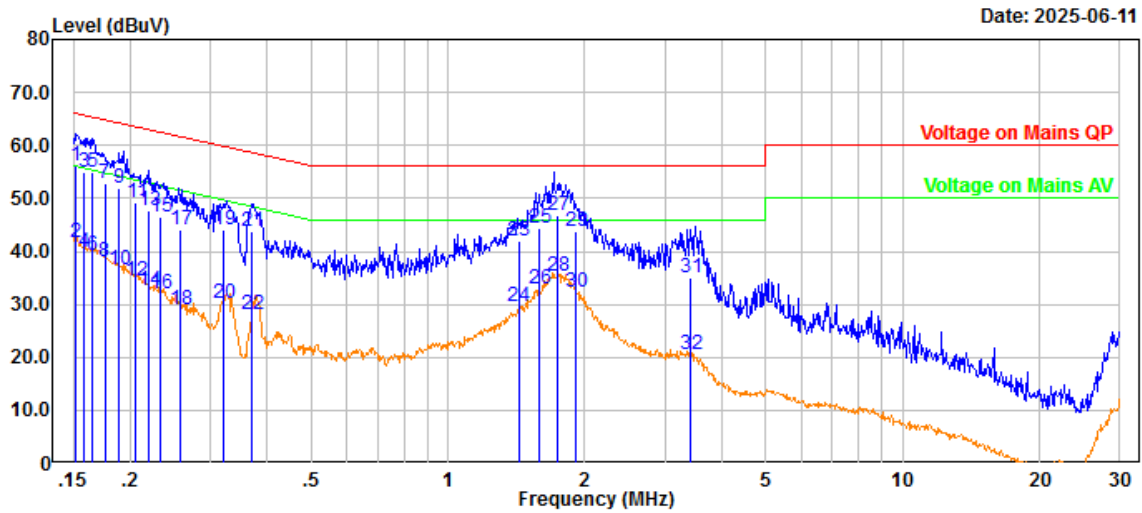

Date: 2025-06-11

No.	Frequency (MHz)	Reading (dBμV)	Factor (dB)	Result (dBμV)	Limit (dBμV)	Margin (dB)	Measurement
1	0.151	45.37	10.80	56.17	65.93	9.76	QP
2	0.151	30.72	10.80	41.52	55.93	14.41	Average
3	0.158	43.99	10.80	54.79	65.56	10.77	QP
4	0.158	29.13	10.80	39.93	55.56	15.63	Average
5	0.165	44.11	10.80	54.91	65.19	10.28	QP
6	0.165	28.56	10.80	39.36	55.19	15.83	Average
7	0.176	42.02	10.80	52.82	64.68	11.86	QP
8	0.176	27.38	10.80	38.18	54.68	16.50	Average
9	0.189	41.07	10.80	51.87	64.09	12.22	QP
10	0.189	25.62	10.80	36.42	54.09	17.67	Average
11	0.206	38.50	10.80	49.30	63.36	14.06	QP
12	0.206	23.70	10.80	34.50	53.36	18.86	Average
13	0.219	36.78	10.79	47.57	62.85	15.28	QP
14	0.219	21.95	10.79	32.74	52.85	20.11	Average
15	0.233	35.73	10.79	46.52	62.33	15.81	QP
16	0.233	21.08	10.79	31.87	52.33	20.46	Average
17	0.259	33.18	10.78	43.96	61.48	17.52	QP
18	0.259	18.11	10.78	28.89	51.48	22.59	Average
19	0.322	33.35	10.76	44.11	59.66	15.55	QP
20	0.322	19.51	10.76	30.27	49.66	19.39	Average
21	0.370	33.15	10.75	43.90	58.49	14.59	QP
22	0.370	17.38	10.75	28.13	48.49	20.36	Average
23	1.429	31.01	10.85	41.86	56.00	14.14	QP
24	1.429	18.72	10.85	29.57	46.00	16.43	Average
25	1.588	33.60	10.87	44.47	56.00	11.53	QP
26	1.588	22.10	10.87	32.97	46.00	13.03	Average
27	1.745	35.85	10.88	46.73	56.00	9.27	QP
28	1.745	24.39	10.88	35.27	46.00	10.73	Average

No.	Frequency (MHz)	Reading (dBµV)	Factor (dB)	Result (dBµV)	Limit (dBµV)	Margin (dB)	Measurement
29	1.915	32.92	10.90	43.82	56.00	12.18	QP
30	1.915	21.30	10.90	32.20	46.00	13.80	Average
31	3.407	24.25	10.84	35.09	56.00	20.91	QP
32	3.407	9.74	10.84	20.58	46.00	25.42	Average

## 5.2 Radiated Spurious Emissions

### 1) 9kHz - 1GHz

Serial Number:	339M-2	Test Date:	2025/6/7
Test Site:	Chamber10m	Test Mode:	Transmitting
Tester:	Leesin Xiang	Test Result:	Pass

<b>Environmental Conditions:</b>					
Temperature: (°C)	24.4	Relative Humidity: (%)	49	ATM Pressure: (kPa)	100.7

#### Test Equipment List and Details:

Manufacturer	Description	Model	Serial Number	Calibration Date	Calibration Due Date
EMCO	Passive Loop Antenna	6512	9706-1206	2023/10/25	2026/10/24
Sunol Sciences	Hybrid Antenna	JB3	A060611-1	2023/9/6	2026/9/5
Narda	Coaxial Attenuator	779-6dB	04269	2023/9/6	2026/9/5
Unknown	Coaxial Cable	C-NJNJ-50	C-1000-01	2024/7/1	2025/6/30
Unknown	Coaxial Cable	C-NJNJ-50	C-0400-04	2024/7/1	2025/6/30
Unknown	Coaxial Cable	C-NJNJ-50	C-0530-01	2024/7/1	2025/6/30
Sonoma	Amplifier	310N	185914	2024/8/26	2025/8/25
R&S	EMI Test Receiver	ESCI	100224	2024/8/26	2025/8/25
Audix	Test Software	E3	191218 V9	N/A	N/A

\* Statement of Traceability: Bay Area Compliance Laboratories Corp. (Dongguan) attests that all calibrations have been performed, traceable to National Primary Standards and International System of Units (SI).

#### Test Data:

Please refer to the below table and plots.

After pre-scan in the X, Y and Z axes of orientation, the worst case is referred to table and plots.

Note: The maximum output power mode and channel: 3DH1(3EDR) mode Highest Channel was tested.

**9kHz~30MHz**

Three antenna orientations (parallel, perpendicular, and ground-parallel) were measured, the worst orientations were below:

Project No.: 2502T01066E-RF  
 Polarization: Parallel  
 Test Mode: Transmitting  
 Note: BT  
 RBW:300Hz VBW:1kHz

Serial No.: 339M-2  
 Tester: Leesin Xiang

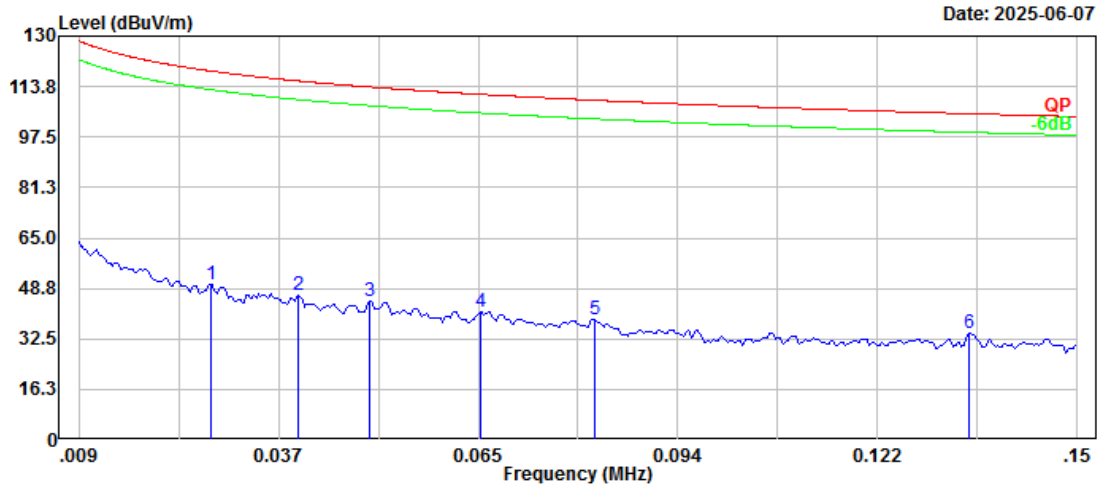

No.	Frequency (MHz)	Reading (dBμV)	Factor (dB/m)	Result (dBμV/m)	Limit (dBμV/m)	Margin (dB)	Measurement
1	0.028	2.10	48.15	50.25	118.78	68.53	Peak
2	0.040	0.62	45.77	46.39	115.56	69.17	Peak
3	0.050	0.63	44.02	44.65	113.60	68.95	Peak
4	0.066	-0.01	41.34	41.33	111.26	69.93	Peak
5	0.082	0.39	38.61	39.00	109.35	70.35	Peak
6	0.135	0.63	33.48	34.11	105.01	70.90	Peak



Project No.: 2502T01066E-RF  
 Polarization: Parallel  
 Test Mode: Transmitting  
 Note: BT  
 RBW:10kHz VBW:30kHz

Serial No.: 339M-2  
 Tester: Leesin Xiang

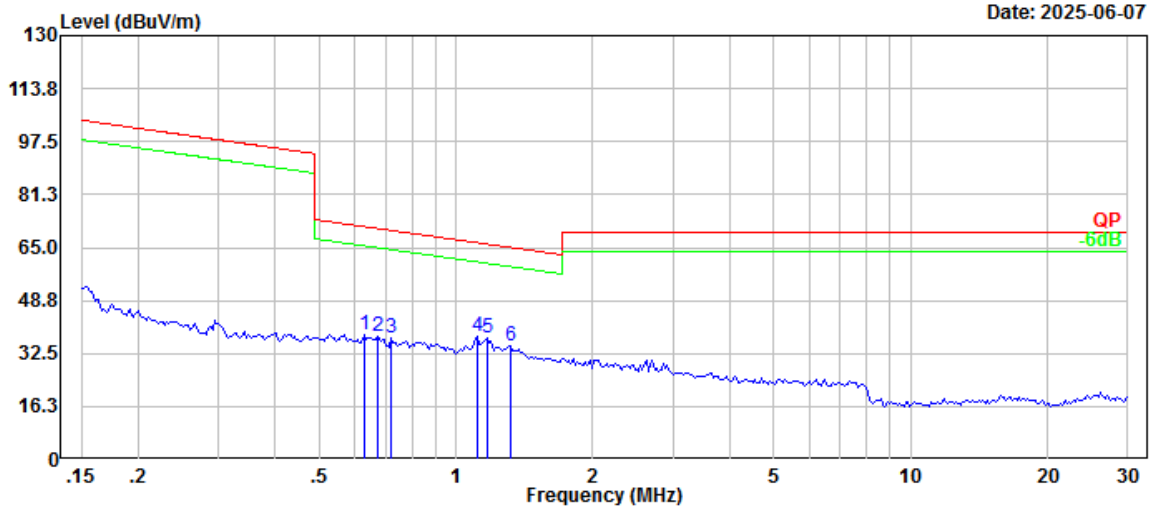

No.	Frequency (MHz)	Reading (dBμV)	Factor (dB/m)	Result (dBμV/m)	Limit (dBμV/m)	Margin (dB)	Measurement
1	0.627	16.12	22.20	38.32	71.61	33.29	Peak
2	0.675	16.24	21.71	37.95	70.95	33.00	Peak
3	0.720	15.79	21.29	37.08	70.39	33.31	Peak
4	1.111	21.53	16.07	37.60	66.54	28.94	Peak
5	1.172	21.35	15.80	37.15	66.07	28.92	Peak
6	1.317	19.92	15.15	35.07	65.03	29.96	Peak

30MHz-1GHz

Project No.: 2502T01066E-RF  
 Polarization: Horizontal  
 Test Mode: Transmitting  
 Note: BT  
 RBW:100kHz VBW:300kHz

Serial No.: 339M-2  
 Tester: Leesin Xiang

Date: 2025-06-07

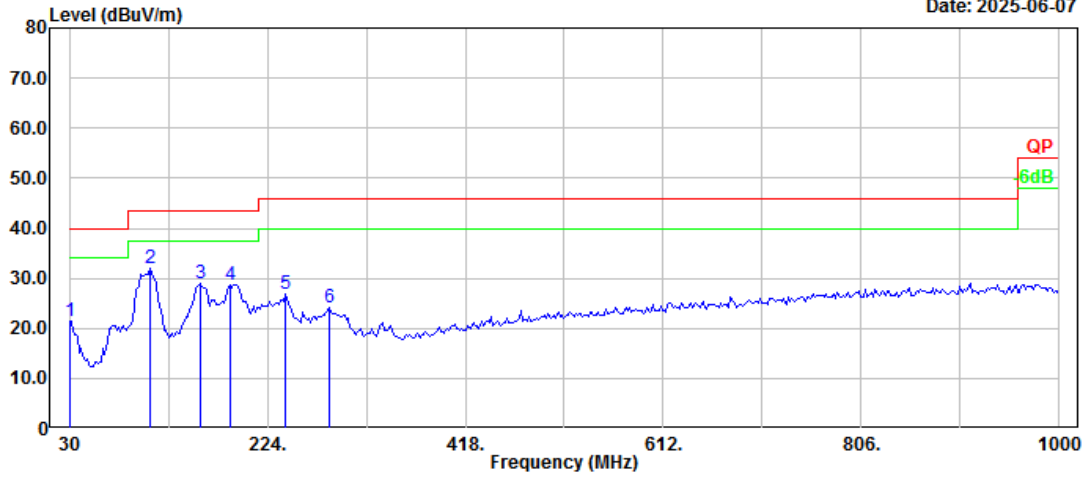

No.	Frequency (MHz)	Reading (dBμV)	Factor (dB/m)	Result (dBμV/m)	Limit (dBμV/m)	Margin (dB)	Measurement
1	30.00	25.37	-3.80	21.57	40.00	18.43	Peak
2	109.54	43.44	-11.49	31.95	43.50	11.55	Peak
3	158.04	40.01	-11.13	28.88	43.50	14.62	Peak
4	187.14	41.02	-12.19	28.83	43.50	14.67	Peak
5	241.46	38.48	-11.71	26.77	46.00	19.23	Peak
6	284.14	33.74	-9.67	24.07	46.00	21.93	Peak

Project No.: 2502T01066E-RF  
 Polarization: Vertical  
 Test Mode: Transmitting  
 Note: BT  
 RBW:100kHz VBW:300kHz

Serial No.: 339M-2  
 Tester: Leesin Xiang

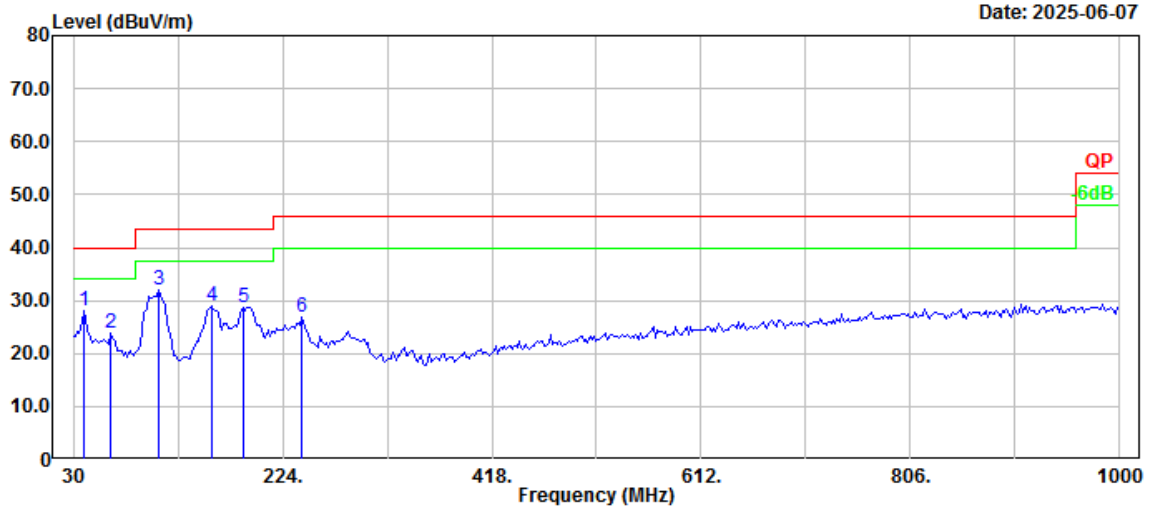

No.	Frequency (MHz)	Reading (dBμV)	Factor (dB/m)	Result (dBμV/m)	Limit (dBμV/m)	Margin (dB)	Measurement
1	39.70	38.77	-10.73	28.04	40.00	11.96	Peak
2	64.92	40.27	-16.50	23.77	40.00	16.23	Peak
3	109.54	43.44	-11.49	31.95	43.50	11.55	Peak
4	158.04	40.01	-11.13	28.88	43.50	14.62	Peak
5	187.14	41.02	-12.19	28.83	43.50	14.67	Peak
6	241.46	38.48	-11.71	26.77	46.00	19.23	Peak

**2) 1-25GHz:**

Serial Number:	339M-2	Test Date:	2025/6/6
Test Site:	Chamber B	Test Mode:	Transmitting
Tester:	Alan Xie	Test Result:	Pass

<b>Environmental Conditions:</b>					
Temperature: (°C)	24.6	Relative Humidity: (%)	39	ATM Pressure: (kPa)	100.9

**Test Equipment List and Details:**

Manufacturer	Description	Model	Serial Number	Calibration Date	Calibration Due Date
ETS-Lindgren	Horn Antenna	3115	000 527 35	2023/9/7	2026/9/6
Ducommun Technologies	Horn Antenna	ARH-4223-02	1007726-02 1304	2023/2/22	2026/2/21
Xinhang Macrowave	Coaxial Cable	XH750A-N/J-SMA/J-10M	20231117004 #0001	2024/11/17	2025/11/16
Xinhang Macrowave	Coaxial Cable	XH360A-2.92/J-2.92/J-6M-A	20231208001 #0001	2024/12/9	2025/12/8
AH	Preamplifier	PAM-0118P	469	2025/4/11	2026/4/10
AH	Preamplifier	PAM-1840VH	191	2024/9/5	2025/9/4
R&S	Spectrum Analyzer	FSV40	101589	2024/9/5	2025/9/4
Audix	Test Software	E3	191218 V9	N/A	N/A
Decentest	Multiplex Switch Test Control Set & Filter Switch Unit	DT7220SCU & DT7220FCU	DC79902 & DC79905	2024/8/27	2025/8/26

*\* Statement of Traceability: Bay Area Compliance Laboratories Corp. (Dongguan) attests that all calibrations have been performed, traceable to National Primary Standards and International System of Units (SI).*

**Test Data:**

Please refer to the below table and plots.  
After pre-scan in the X, Y and Z axes of orientation, the worst case is referred to table and plots.

*Note: The maximum output power mode: 3DH1(3EDR) mode was tested.*

### 3EDR Mode low channel Horizontal

Project No.: 2502T01066E-RF  
 Polarization: Horizontal  
 Test Mode: Transmitting  
 Note: 3EDR Mode low channel 2402MHz  
 Peak:RBW:1MHz,VBW:3MHz

Serial No.: 339H-2  
 Tester: Alan Xie

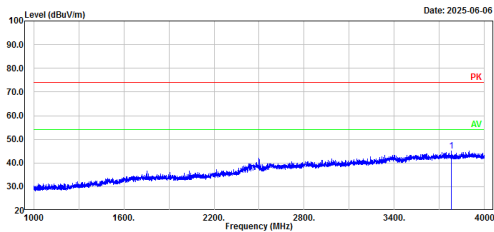

No.	Frequency (MHz)	Reading (dBuV)	Factor (dB/m)	Result (dBuV/m)	Limit (dBuV/m)	Margin (dB)	Measurement
1	3778.00	49.42	-4.31	45.11	74.00	28.89	Peak

### 3EDR Mode low channel Vertical

Project No.: 2502T01066E-RF  
 Polarization: Vertical  
 Test Mode: Transmitting  
 Note: 3EDR Mode low channel 2402MHz  
 Peak:RBW:1MHz,VBW:3MHz

Serial No.: 339H-2  
 Tester: Alan Xie

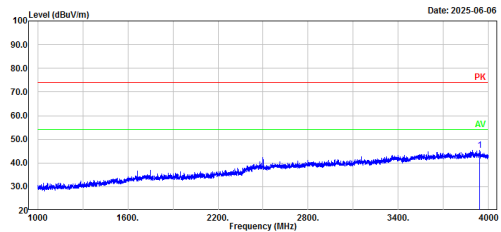

No.	Frequency (MHz)	Reading (dBuV)	Factor (dB/m)	Result (dBuV/m)	Limit (dBuV/m)	Margin (dB)	Measurement
1	3940.00	49.19	-3.68	45.51	74.00	28.49	Peak

Project No.: 2502T01066E-RF  
 Polarization: Horizontal  
 Test Mode: Transmitting  
 Note: 3EDR Mode low channel 2402MHz  
 Peak:RBW:1MHz,VBW:3MHz Ave:RBW:1MHz,VBW:5kHz

Serial No.: 339H-2  
 Tester: Alan Xie

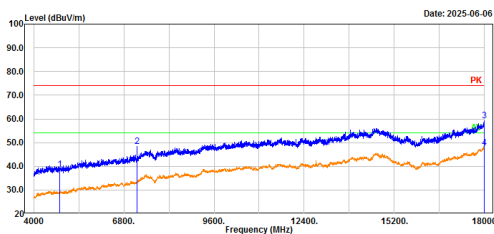

No.	Frequency (MHz)	Reading (dBuV)	Factor (dB/m)	Result (dBuV/m)	Limit (dBuV/m)	Margin (dB)	Measurement
1	4804.00	47.23	-8.62	38.61	74.00	35.39	Peak
2	7206.00	52.14	-3.81	48.33	74.00	25.67	Peak
3	17997.20	47.95	11.38	59.33	74.00	14.67	Peak
4	17997.20	36.27	11.38	47.65	54.00	6.35	Average

Project No.: 2502T01066E-RF  
 Polarization: Vertical  
 Test Mode: Transmitting  
 Note: 3EDR Mode low channel 2402MHz  
 Peak:RBW:1MHz,VBW:3MHz Ave:RBW:1MHz,VBW:5kHz

Serial No.: 339H-2  
 Tester: Alan Xie

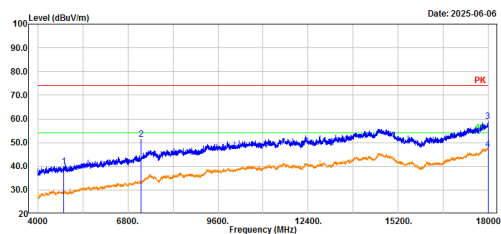

No.	Frequency (MHz)	Reading (dBuV)	Factor (dB/m)	Result (dBuV/m)	Limit (dBuV/m)	Margin (dB)	Measurement
1	4804.00	48.64	-8.62	40.02	74.00	33.98	Peak
2	7206.00	55.34	-3.81	51.53	74.00	22.47	Peak
3	17980.40	47.50	11.30	58.80	74.00	15.20	Peak
4	17980.40	35.87	11.30	47.17	54.00	6.83	Average

### 3EDR Mode middle channel Horizontal

Project No.: 2502T01066E-RF  
 Polarization: Horizontal  
 Test Mode: Transmitting  
 Note: 3EDR Mode middle channel 2441MHz  
 Peak:RBW:1MHz,VBW:30Hz

Serial No.: 339H-2  
 Tester: Alan Xie

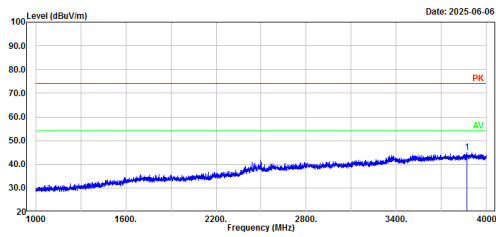

No.	Frequency (MHz)	Reading (dBuV)	Factor (dB/m)	Result (dBuV/m)	Limit (dBuV/m)	Margin (dB)	Measurement
1	3871.60	49.14	-3.96	45.18	74.00	28.82	Peak

### 3EDR Mode middle channel Vertical

Project No.: 2502T01066E-RF  
 Polarization: Vertical  
 Test Mode: Transmitting  
 Note: 3EDR Mode middle channel 2441MHz  
 Peak:RBW:1MHz,VBW:30Hz

Serial No.: 339H-2  
 Tester: Alan Xie

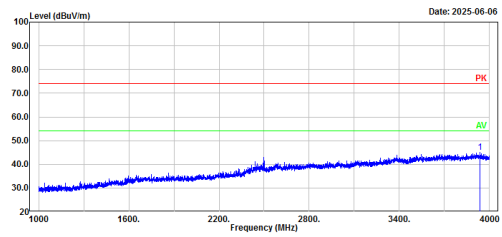

No.	Frequency (MHz)	Reading (dBuV)	Factor (dB/m)	Result (dBuV/m)	Limit (dBuV/m)	Margin (dB)	Measurement
1	3937.60	48.66	-3.70	44.96	74.00	29.04	Peak

Project No.: 2502T01066E-RF  
 Polarization: Horizontal  
 Test Mode: Transmitting  
 Note: 3EDR Mode middle channel 2441MHz  
 Peak:RBW:1MHz,VBW:30Hz Ave:RBW:1MHz,VBW:5kHz

Serial No.: 339H-2  
 Tester: Alan Xie

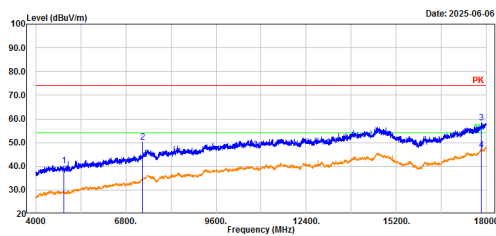

No.	Frequency (MHz)	Reading (dBuV)	Factor (dB/m)	Result (dBuV/m)	Limit (dBuV/m)	Margin (dB)	Measurement
1	4882.00	48.64	-8.47	40.17	74.00	33.83	Peak
2	7323.00	53.47	-3.19	50.28	74.00	23.72	Peak
3	17834.80	47.92	10.38	58.30	74.00	15.70	Peak
4	17834.80	36.56	10.38	46.94	54.00	7.06	Average

Project No.: 2502T01066E-RF  
 Polarization: Vertical  
 Test Mode: Transmitting  
 Note: 3EDR Mode middle channel 2441MHz  
 Peak:RBW:1MHz,VBW:30Hz Ave:RBW:1MHz,VBW:5kHz

Serial No.: 339H-2  
 Tester: Alan Xie

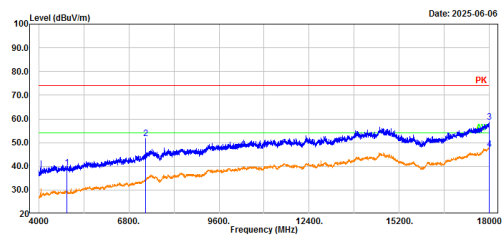

No.	Frequency (MHz)	Reading (dBuV)	Factor (dB/m)	Result (dBuV/m)	Limit (dBuV/m)	Margin (dB)	Measurement
1	4882.00	47.85	-8.47	39.38	74.00	34.62	Peak
2	7323.00	54.93	-3.19	51.74	74.00	22.26	Peak
3	17991.60	47.27	11.35	58.62	74.00	15.38	Peak
4	17991.60	35.85	11.35	47.20	54.00	6.80	Average

### 3EDR Mode high channel Horizontal

Project No.: 2502T01066E-RF  
 Polarization: Horizontal  
 Test Mode: Transmitting  
 Note: 3EDR Mode high channel 2400MHz  
 Peak: RBW:1MHz, VBW:30Hz

Serial No.: 339H-2  
 Tester: Alan Xie

Date: 2025-06-06

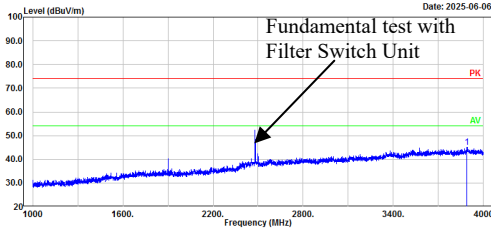

No.	Frequency (MHz)	Reading (dBuV)	Factor (dB/m)	Result (dBuV/m)	Limit (dBuV/m)	Margin (dB)	Measurement
1	3889.60	48.85	-3.76	45.09	74.00	28.91	Peak

### 3EDR Mode high channel Vertical

Project No.: 2502T01066E-RF  
 Polarization: Vertical  
 Test Mode: Transmitting  
 Note: 3EDR Mode high channel 2400MHz  
 Peak: RBW:1MHz, VBW:30Hz

Serial No.: 339H-2  
 Tester: Alan Xie

Date: 2025-06-06

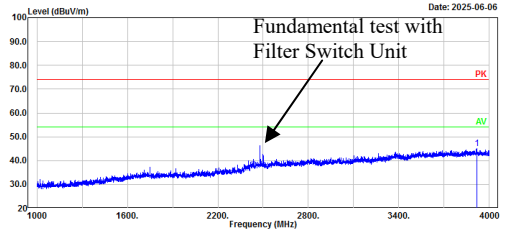

No.	Frequency (MHz)	Reading (dBuV)	Factor (dB/m)	Result (dBuV/m)	Limit (dBuV/m)	Margin (dB)	Measurement
1	3916.60	48.69	-3.74	44.95	74.00	29.05	Peak

Project No.: 2502T01066E-RF  
 Polarization: Horizontal  
 Test Mode: Transmitting  
 Note: 3EDR Mode high channel 2400MHz  
 Peak: RBW:1MHz, VBW:30Hz Ave:RBW:1MHz, VBW:5kHz

Serial No.: 339H-2  
 Tester: Alan Xie

Date: 2025-06-06

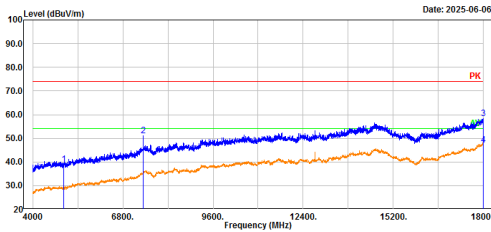

No.	Frequency (MHz)	Reading (dBuV)	Factor (dB/m)	Result (dBuV/m)	Limit (dBuV/m)	Margin (dB)	Measurement
1	4960.00	47.56	-8.48	39.08	74.00	34.92	Peak
2	7440.00	53.62	-2.62	51.00	74.00	23.00	Peak
3	17993.00	46.98	11.37	58.35	74.00	15.65	Peak
4	17993.00	35.85	11.37	47.22	54.00	6.78	Average

Project No.: 2502T01066E-RF  
 Polarization: Vertical  
 Test Mode: Transmitting  
 Note: 3EDR Mode high channel 2400MHz  
 Peak: RBW:1MHz, VBW:30Hz Ave:RBW:1MHz, VBW:5kHz

Serial No.: 339H-2  
 Tester: Alan Xie

Date: 2025-06-06

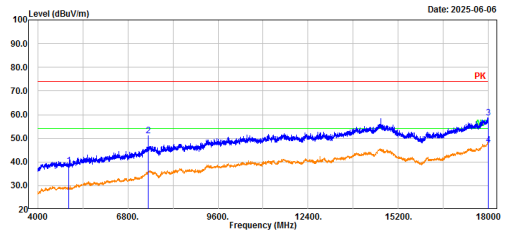

No.	Frequency (MHz)	Reading (dBuV)	Factor (dB/m)	Result (dBuV/m)	Limit (dBuV/m)	Margin (dB)	Measurement
1	4960.00	46.99	-8.48	38.51	74.00	35.49	Peak
2	7440.00	53.74	-2.62	51.12	74.00	22.88	Peak
3	17986.00	47.43	11.32	58.75	74.00	15.25	Peak
4	17986.00	35.93	11.32	47.25	54.00	6.75	Average

**18-25GHz:**

*Note: No Emission was detected in the range 18-25GHz, the maximum output power mode and channel: 3DHI(3EDR) mode Highest Channel was tested.*

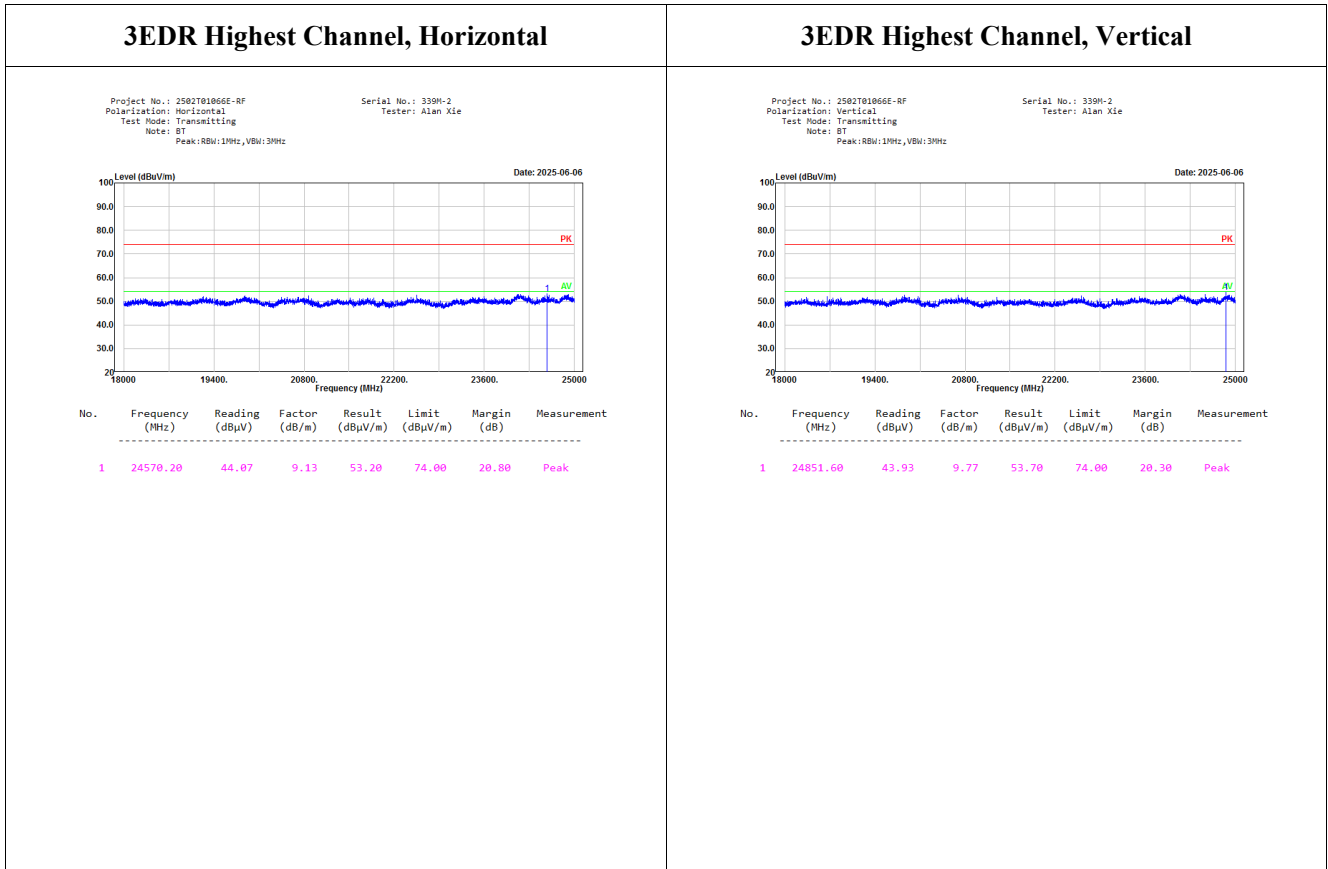



**Bandedge:**

**3EDR Mode low channel Bandedge Horizontal**

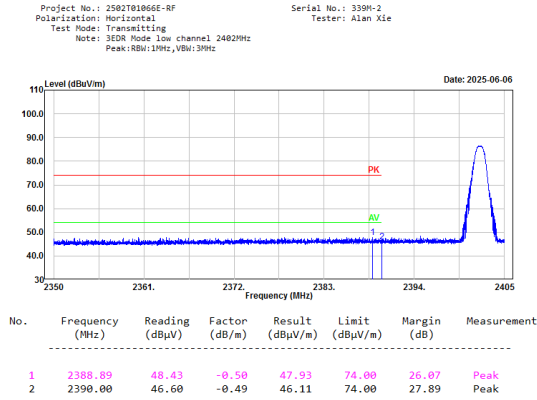

**3EDR Mode low channel Bandedge Vertical**

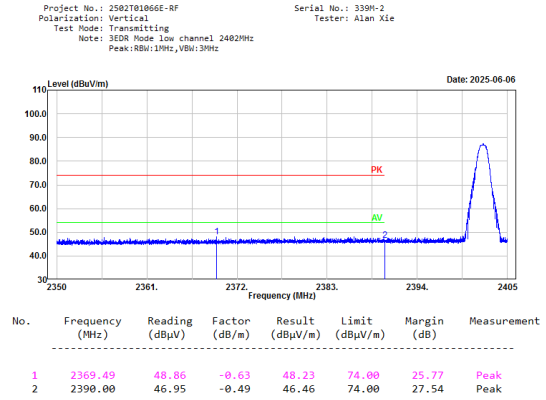

**3EDR Mode high channel Bandedge Horizontal**

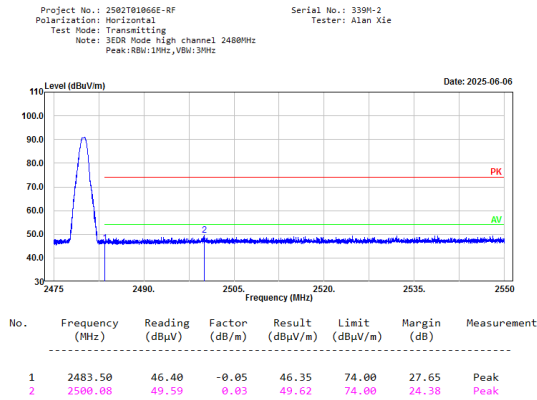

**3EDR Mode high channel Bandedge Vertical**

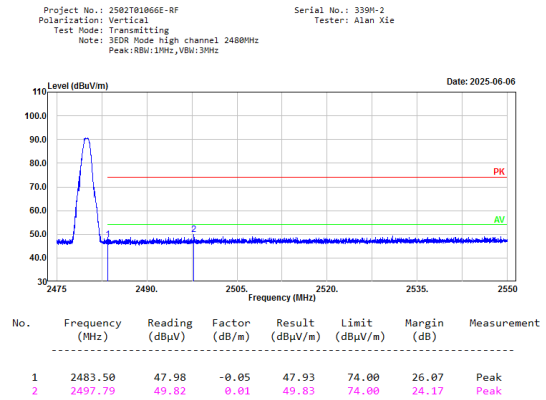

**5.3 20 dB Emission Bandwidth**

**Test Information:**

<b>Serial No.:</b>	339M-1	<b>Test Date:</b>	2025/06/12
<b>Test Site:</b>	RF	<b>Test Mode:</b>	Transmitting
<b>Tester:</b>	Conor Fu	<b>Test Result:</b>	N/A

**Environmental Conditions:**

<b>Temperature:</b> (°C)	25.5	<b>Relative Humidity:</b> (%)	55	<b>ATM Pressure:</b> (kPa)	100.6
-----------------------------	------	----------------------------------	----	-------------------------------	-------

**Test Equipment List and Details:**

Manufacturer	Description	Model	Serial Number	Calibration Date	Calibration Due Date
R&S	Spectrum Analyzer	FSP 38	100478	2024/09/05	2025/09/04
R&S	Wideband Radio Communication Tester	CMW500	149216	2024/09/05	2025/09/04
Gongee	Coaxial Power Splitters & Combiner	PD-0/6-2S	RF20230800110	2025/01/15	2026/01/14
Narda	Coaxial Attenuator	773-10	F-08-EM511	2025/06/07	2026/06/06

*\* Statement of Traceability: Bay Area Compliance Laboratories Corp. (Dongguan) attests that all calibrations have been performed, traceable to National Primary Standards and International System of Units (SI).*

**Test Data:**

Mode	Channel	Result (MHz)
DH1	Low	0.933
	Middle	0.933
	High	0.936
2DH1	Low	1.284
	Middle	1.281
	High	1.284
3DH1	Low	1.278
	Middle	1.278
	High	1.281

### DH1\_Low

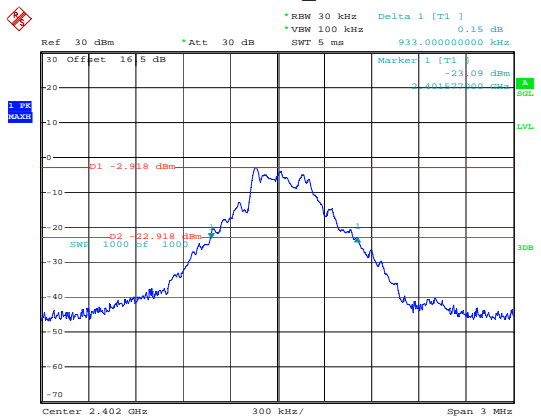

ProjectNo.:2502T01066E-RF Tester:Conor Fu  
Date: 12.JUN.2025 00:11:17

### DH1\_Middle

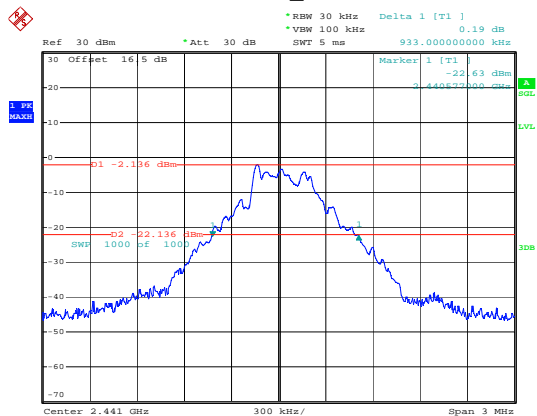

ProjectNo.:2502T01066E-RF Tester:Conor Fu  
Date: 12.JUN.2025 00:15:52

### DH1\_High

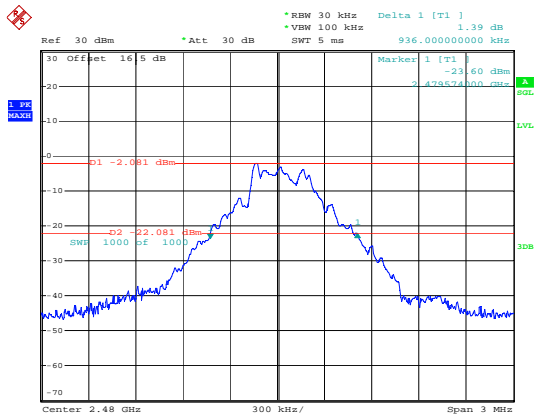

ProjectNo.:2502T01066E-RF Tester:Conor Fu  
Date: 12.JUN.2025 00:17:56

### 2DH1\_Low

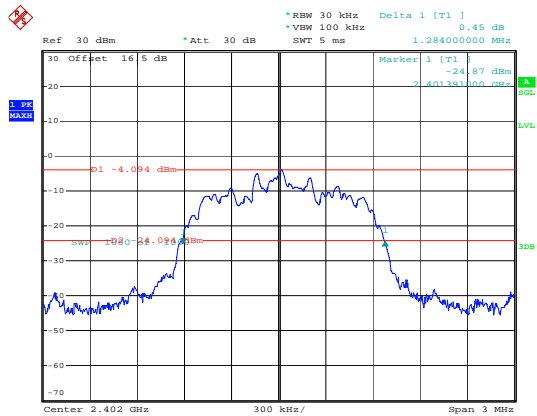

ProjectNo.:2502T01066E-RF Tester:Conor Fu  
Date: 12.JUN.2025 00:27:44

### 2DH1\_Middle

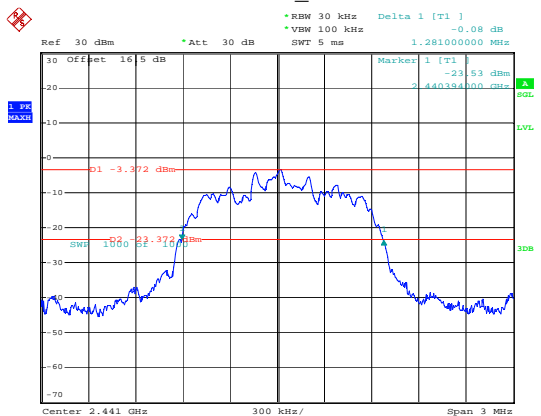

ProjectNo.:2502T01066E-RF Tester:Conor Fu  
Date: 12.JUN.2025 00:33:52

### 2DH1\_High

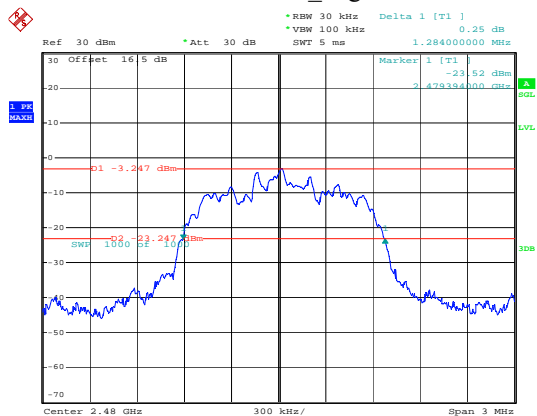

ProjectNo.:2502T01066E-RF Tester:Conor Fu  
Date: 12.JUN.2025 00:35:48

3DH1\_Low

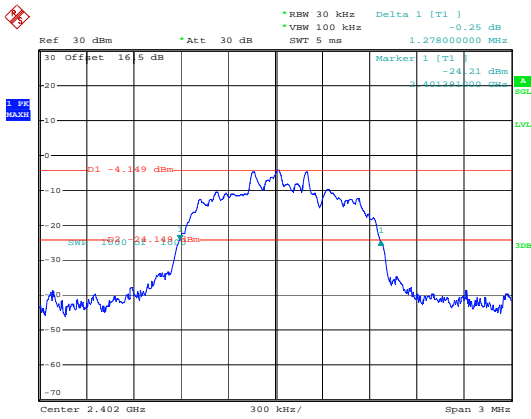

ProjectNo.:2502T01066E-RF Tester:Conor Fu  
 Date: 12.JUN.2025 00:41:10

3DH1\_Middle

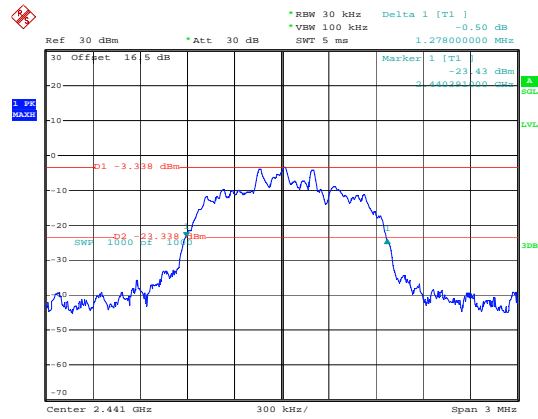

ProjectNo.:2502T01066E-RF Tester:Conor Fu  
 Date: 12.JUN.2025 00:46:03

3DH1\_High

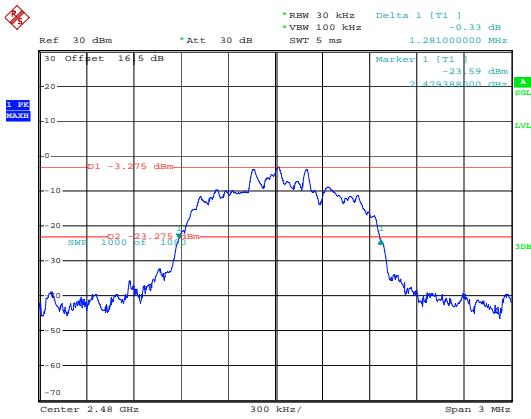

ProjectNo.:2502T01066E-RF Tester:Conor Fu  
 Date: 12.JUN.2025 00:47:59

**5.4 Channel Separation**

**Test Information:**

<b>Serial No.:</b>	339M-1	<b>Test Date:</b>	2025/06/12
<b>Test Site:</b>	RF	<b>Test Mode:</b>	Transmitting
<b>Tester:</b>	Conor Fu	<b>Test Result:</b>	Pass

**Environmental Conditions:**

<b>Temperature:</b> (°C)	25.5	<b>Relative Humidity:</b> (%)	55	<b>ATM Pressure:</b> (kPa)	100.6
-----------------------------	------	----------------------------------	----	-------------------------------	-------

**Test Equipment List and Details:**

Manufacturer	Description	Model	Serial Number	Calibration Date	Calibration Due Date
R&S	Spectrum Analyzer	FSP 38	100478	2024/09/05	2025/09/04
R&S	Wideband Radio Communication Tester	CMW500	149216	2024/09/05	2025/09/04
Gongee	Coaxial Power Splitters & Combiner	PD-0/6-2S	RF20230800110	2025/01/15	2026/01/14
Narda	Coaxial Attenuator	773-10	F-08-EM511	2025/06/07	2026/06/06

*\* Statement of Traceability: Bay Area Compliance Laboratories Corp. (Dongguan) attests that all calibrations have been performed, traceable to National Primary Standards and International System of Units (SI).*

**Test Data:**

Mode	Channel	Result (MHz)	Limit (MHz)	Verdict
DH1	Low	0.994	0.856	Pass
	Middle	1.002	0.856	Pass
	High	1.006	0.856	Pass

*Note:*

- 1. Only GFSK mode result is reported since EDR ( $\pi/4$ -DQPSK, 8DPSK) has the exact same channel plan.*
- 2. The limit is maximum 20dB bandwidth\*2/3.*

### DH1\_Low

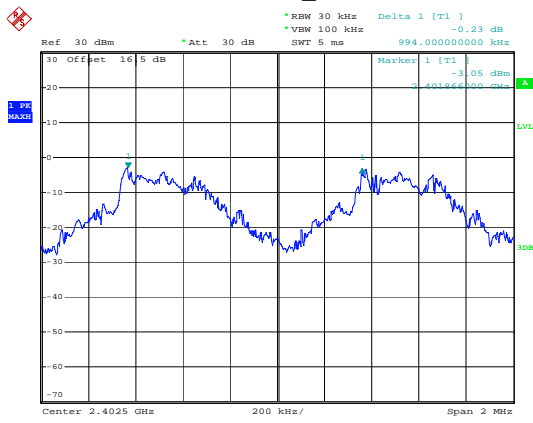

ProjectNo.:2502T01066E-RF Tester:Conor Fu  
Date: 12.JUN.2025 20:03:47

### DH1\_Middle

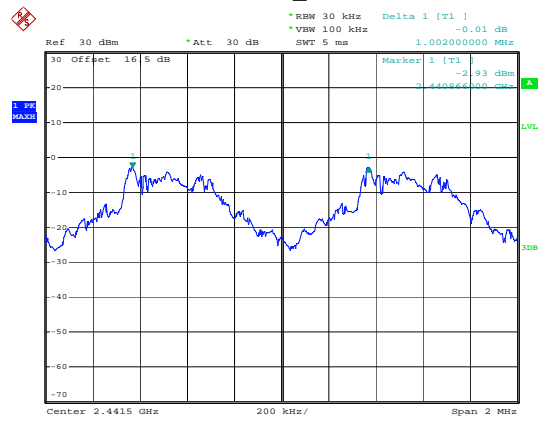

ProjectNo.:2502T01066E-RF Tester:Conor Fu  
Date: 12.JUN.2025 20:09:39

### DH1\_High

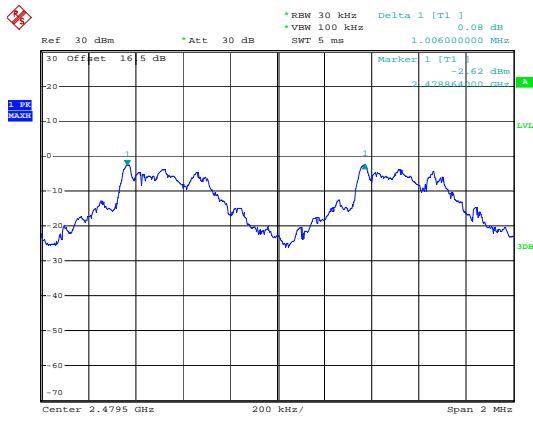

ProjectNo.:2502T01066E-RF Tester:Conor Fu  
Date: 12.JUN.2025 20:17:09

### 5.5 Number of Hopping Frequency

**Test Information:**

<b>Serial No.:</b>	339M-1	<b>Test Date:</b>	2025/06/12
<b>Test Site:</b>	RF	<b>Test Mode:</b>	Transmitting
<b>Tester:</b>	Conor Fu	<b>Test Result:</b>	Pass

**Environmental Conditions:**

<b>Temperature:</b> (°C)	25.5	<b>Relative Humidity:</b> (%)	55	<b>ATM Pressure:</b> (kPa)	100.6
-----------------------------	------	----------------------------------	----	-------------------------------	-------

**Test Equipment List and Details:**

Manufacturer	Description	Model	Serial Number	Calibration Date	Calibration Due Date
R&S	Spectrum Analyzer	FSP 38	100478	2024/09/05	2025/09/04
R&S	Wideband Radio Communication Tester	CMW500	149216	2024/09/05	2025/09/04
Gongee	Coaxial Power Splitters & Combiner	PD-0/6-2S	RF20230800110	2025/01/15	2026/01/14
Narda	Coaxial Attenuator	773-10	F-08-EM511	2025/06/07	2026/06/06

\* Statement of Traceability: Bay Area Compliance Laboratories Corp. (Dongguan) attests that all calibrations have been performed, traceable to National Primary Standards and International System of Units (SI).

**Test Data:**

Mode	Channel	Result	Limit	Verdict
DH1	Hopping	79	15	Pass

*Note:*

1. Only GFSK mode result is reported since EDR ( $\pi/4$ -DQPSK, 8DPSK) has the exact same channel plan.

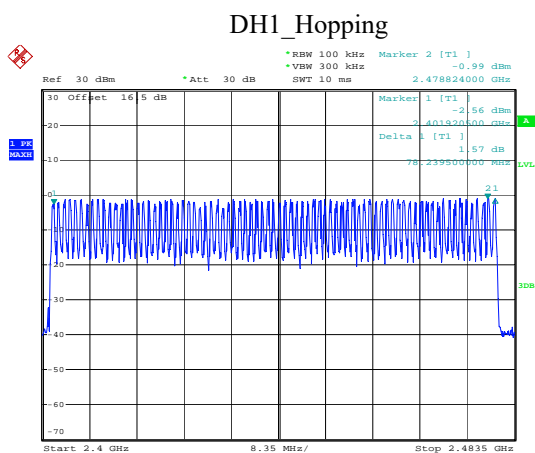

ProjectNo.: 2502T01066E-RF Tester: Conor Fu  
Date: 12 JUN 2025 19:35:38

**5.6 Time of Occupancy (Dwell Time)**

**Test Information:**

<b>Serial No.:</b>	339M-1	<b>Test Date:</b>	2025/06/12
<b>Test Site:</b>	RF	<b>Test Mode:</b>	Transmitting
<b>Tester:</b>	Conor Fu	<b>Test Result:</b>	Pass

**Environmental Conditions:**

<b>Temperature:</b> (°C)	25.5	<b>Relative Humidity:</b> (%)	55	<b>ATM Pressure:</b> (kPa)	100.6
-----------------------------	------	----------------------------------	----	-------------------------------	-------

**Test Equipment List and Details:**

Manufacturer	Description	Model	Serial Number	Calibration Date	Calibration Due Date
R&S	Spectrum Analyzer	FSP 38	100478	2024/09/05	2025/09/04
R&S	Wideband Radio Communication Tester	CMW500	149216	2024/09/05	2025/09/04
Gongee	Coaxial Power Splitters & Combiner	PD-0/6-2S	RF20230800110	2025/01/15	2026/01/14
Narda	Coaxial Attenuator	773-10	F-08-EM511	2025/06/07	2026/06/06

\* Statement of Traceability: Bay Area Compliance Laboratories Corp. (Dongguan) attests that all calibrations have been performed, traceable to National Primary Standards and International System of Units (SI).

**Test Data:**

Mode	Channel	Pulse width (ms)	Dwell time (s)	Limit (s)	Verdict
DH1	Hopping	0.404	0.129	0.400	Pass
DH3	Hopping	1.662	0.266	0.400	Pass
DH5	Hopping	2.930	0.313	0.400	Pass
2DH1	Hopping	0.394	0.126	0.400	Pass
2DH3	Hopping	1.650	0.264	0.400	Pass
2DH5	Hopping	2.920	0.311	0.400	Pass
3DH1	Hopping	0.397	0.127	0.400	Pass
3DH3	Hopping	1.647	0.264	0.400	Pass
3DH5	Hopping	2.915	0.311	0.400	Pass

**Note:**

DH1: Dwell time = Pulse width (ms) × (1600/2/79) × 31.6 s  
 DH3: Dwell time = Pulse width (ms) × (1600/4/79) × 31.6 s  
 DH5: Dwell time = Pulse width (ms) × (1600/6/79) × 31.6 s  
 2DH1: Dwell time = Pulse width (ms) × (1600/2/79) × 31.6 s  
 2DH3: Dwell time = Pulse width (ms) × (1600/4/79) × 31.6 s  
 2DH5: Dwell time = Pulse width (ms) × (1600/6/79) × 31.6 s  
 3DH1: Dwell time = Pulse width (ms) × (1600/2/79) × 31.6 s  
 3DH3: Dwell time = Pulse width (ms) × (1600/4/79) × 31.6 s  
 3DH5: Dwell time = Pulse width (ms) × (1600/6/79) × 31.6 s



### DH1\_Hopping

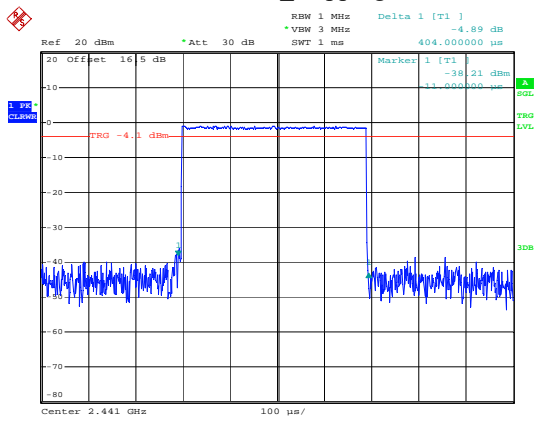

ProjectNo.:2502T01066E-RF Tester:Conor Fu  
Date: 12.JUN.2025 19:43:15

### DH3\_Hopping

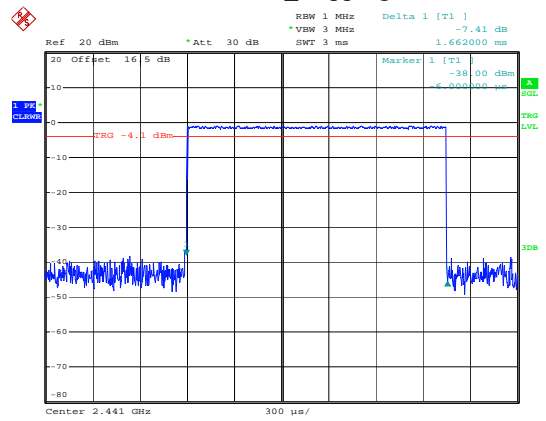

ProjectNo.:2502T01066E-RF Tester:Conor Fu  
Date: 12.JUN.2025 19:44:01

### DH5\_Hopping

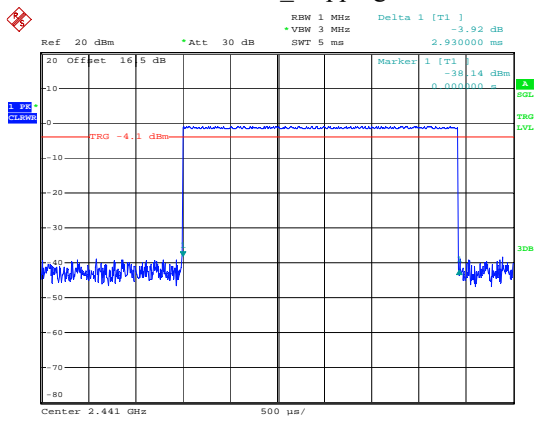

ProjectNo.:2502T01066E-RF Tester:Conor Fu  
Date: 12.JUN.2025 19:44:44

### 2DH1\_Hopping

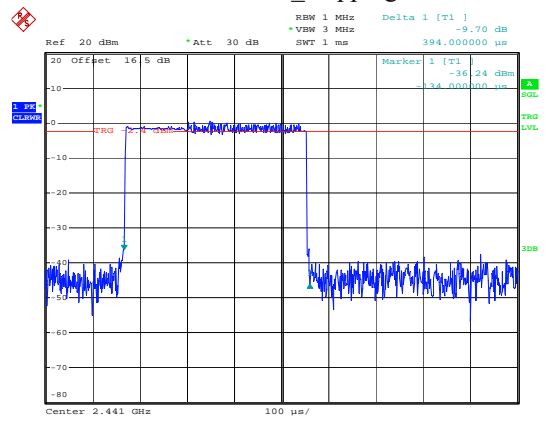

ProjectNo.:2502T01066E-RF Tester:Conor Fu  
Date: 12.JUN.2025 19:56:43

### 2DH3\_Hopping

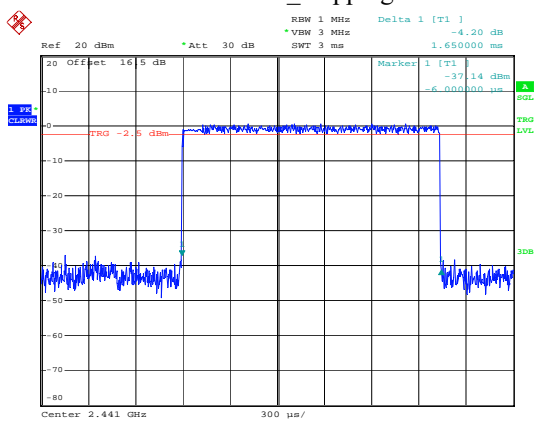

ProjectNo.:2502T01066E-RF Tester:Conor Fu  
Date: 12.JUN.2025 19:46:29

### 2DH5\_Hopping

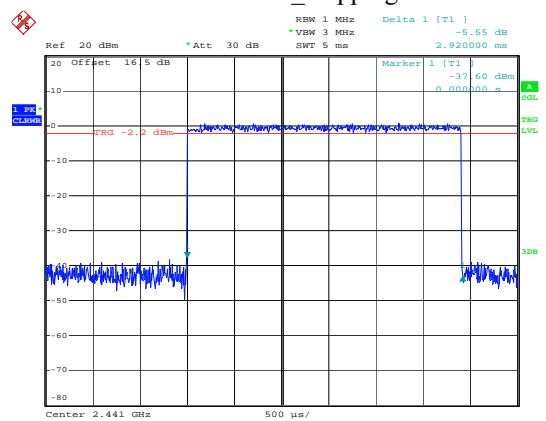

ProjectNo.:2502T01066E-RF Tester:Conor Fu  
Date: 12.JUN.2025 19:47:32

### 3DH1\_Hopping

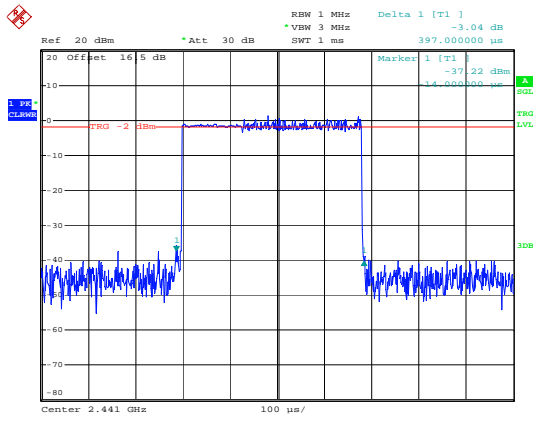

ProjectNo.:2502T01066E-RF Tester:Conor Fu  
Date: 12.JUN.2025 19:53:21

### 3DH3\_Hopping

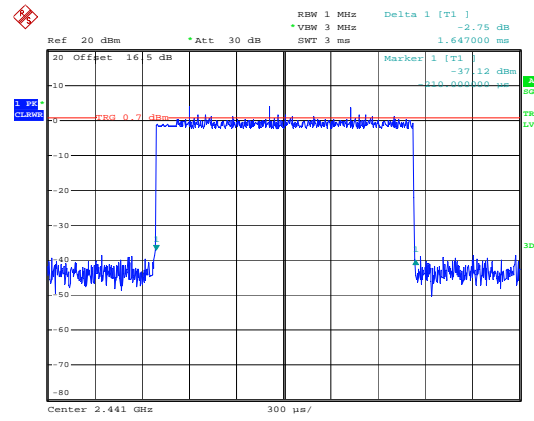

ProjectNo.:2502T01066E-RF Tester:Conor Fu  
Date: 12.JUN.2025 19:54:18

### 3DH5\_Hopping

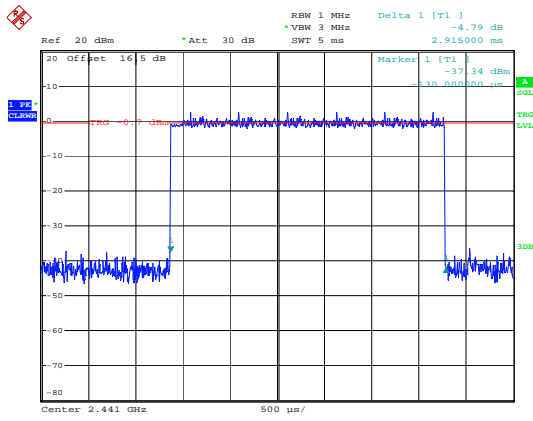

ProjectNo.:2502T01066E-RF Tester:Conor Fu  
Date: 12.JUN.2025 19:55:09

**5.7 Maximum Conducted Output Power**

**Test Information:**

<b>Serial No.:</b>	339M-1	<b>Test Date:</b>	2025/06/12
<b>Test Site:</b>	RF	<b>Test Mode:</b>	Transmitting
<b>Tester:</b>	Conor Fu	<b>Test Result:</b>	Pass

**Environmental Conditions:**

<b>Temperature:</b> (°C)	25.5	<b>Relative Humidity:</b> (%)	55	<b>ATM Pressure:</b> (kPa)	100.6
-----------------------------	------	----------------------------------	----	-------------------------------	-------

**Test Equipment List and Details:**

Manufacturer	Description	Model	Serial Number	Calibration Date	Calibration Due Date
R&S	Spectrum Analyzer	FSP 38	100478	2024/09/05	2025/09/04
R&S	Wideband Radio Communication Tester	CMW500	149216	2024/09/05	2025/09/04
Gongee	Coaxial Power Splitters & Combiner	PD-0/6-2S	RF20230800110	2025/01/15	2026/01/14
Narda	Coaxial Attenuator	773-10	F-08-EM511	2025/06/07	2026/06/06

\* Statement of Traceability: Bay Area Compliance Laboratories Corp. (Dongguan) attests that all calibrations have been performed, traceable to National Primary Standards and International System of Units (SI).

**Test Data:**

Mode	Test Frequency (MHz)	Peak Output Power (dBm)	Limit (dBm)	Verdict
DH1	2402	-0.85	21.00	Pass
	2441	-0.08	21.00	Pass
	2480	-0.03	21.00	Pass
2DH1	2402	1.80	21.00	Pass
	2441	2.59	21.00	Pass
	2480	2.64	21.00	Pass
3DH1	2402	2.38	21.00	Pass
	2441	3.12	21.00	Pass
	2480	3.17	21.00	Pass

DH1\_Low

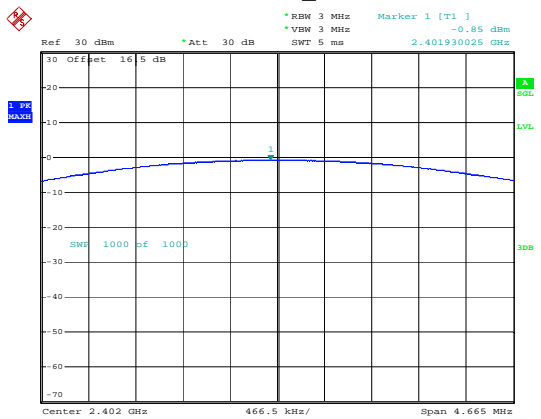

ProjectNo.:2502T01066E-RF Tester:Conor Fu  
Date: 12.JUN.2025 00:12:43

DH1\_Middle

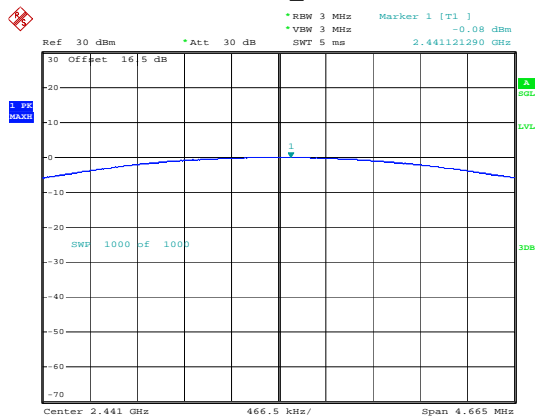

ProjectNo.:2502T01066E-RF Tester:Conor Fu  
Date: 12.JUN.2025 00:17:04

DH1\_High

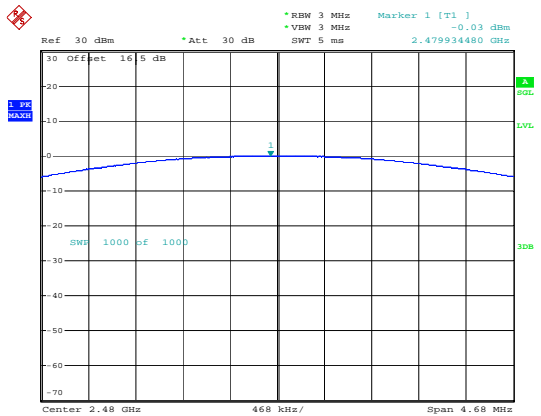

ProjectNo.:2502T01066E-RF Tester:Conor Fu  
Date: 12.JUN.2025 00:19:07

2DH1\_Low

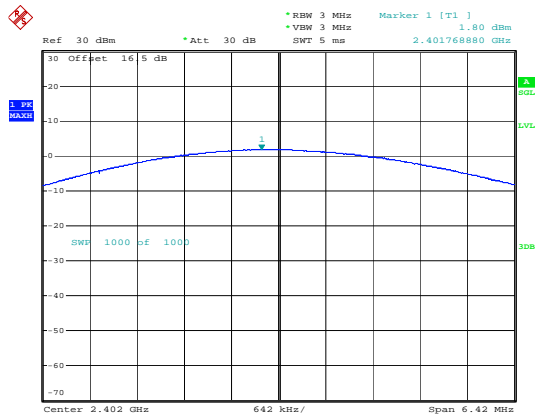

ProjectNo.:2502T01066E-RF Tester:Conor Fu  
Date: 12.JUN.2025 00:30:28

2DH1\_Middle

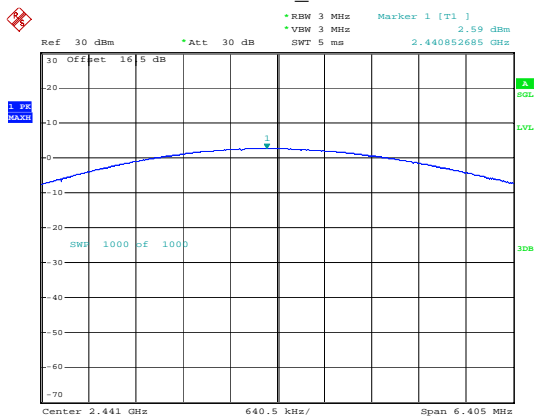

ProjectNo.:2502T01066E-RF Tester:Conor Fu  
Date: 12.JUN.2025 00:35:04

2DH1\_High

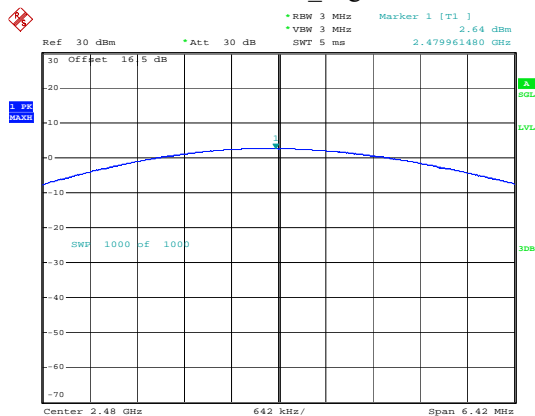

ProjectNo.:2502T01066E-RF Tester:Conor Fu  
Date: 12.JUN.2025 00:36:59

### 3DH1\_Low

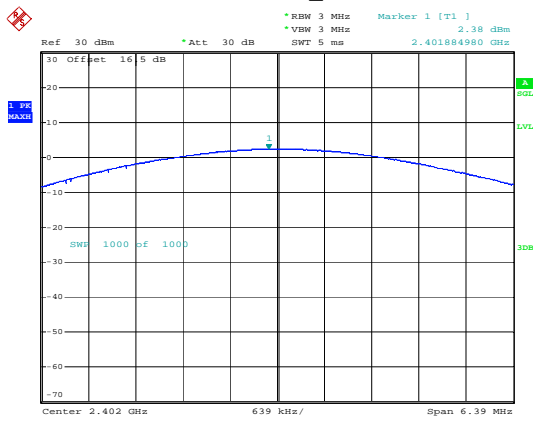

ProjectNo.:2502T01066E-RF Tester:Conor Fu  
Date: 12.JUN.2025 00:42:39

### 3DH1\_Middle

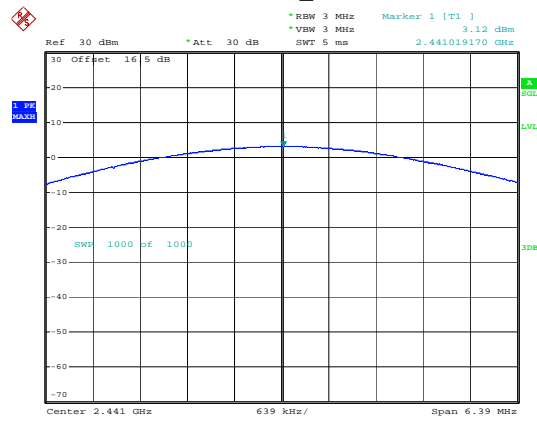

ProjectNo.:2502T01066E-RF Tester:Conor Fu  
Date: 12.JUN.2025 00:47:15

### 3DH1\_High

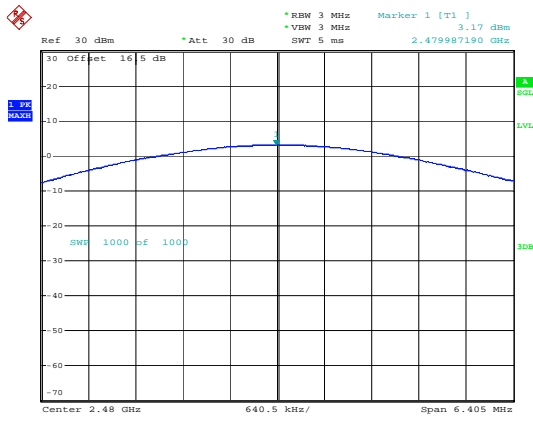

ProjectNo.:2502T01066E-RF Tester:Conor Fu  
Date: 12.JUN.2025 00:49:09

**5.8 100 kHz Bandwidth of Frequency Band Edge**

**Test Information:**

<b>Serial No.:</b>	339M-1	<b>Test Date:</b>	2025/06/12
<b>Test Site:</b>	RF	<b>Test Mode:</b>	Transmitting
<b>Tester:</b>	Conor Fu	<b>Test Result:</b>	Pass

**Environmental Conditions:**

<b>Temperature:</b> (°C)	25.5	<b>Relative Humidity:</b> (%)	55	<b>ATM Pressure:</b> (kPa)	100.6
-----------------------------	------	----------------------------------	----	-------------------------------	-------

**Test Equipment List and Details:**

Manufacturer	Description	Model	Serial Number	Calibration Date	Calibration Due Date
R&S	Spectrum Analyzer	FSP 38	100478	2024/09/05	2025/09/04
R&S	Wideband Radio Communication Tester	CMW500	149216	2024/09/05	2025/09/04
Gongee	Coaxial Power Splitters & Combiner	PD-0/6-2S	RF20230800110	2025/01/15	2026/01/14
Narda	Coaxial Attenuator	773-10	F-08-EM511	2025/06/07	2026/06/06

*\* Statement of Traceability: Bay Area Compliance Laboratories Corp. (Dongguan) attests that all calibrations have been performed, traceable to National Primary Standards and International System of Units (SI).*

**Test Data as following plots:**

### DH1\_Low

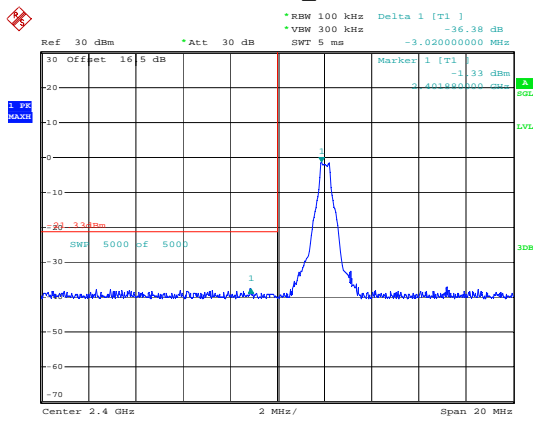

ProjectNo.:2502T01066E-RF Tester:Conor Fu  
Date: 12.JUN.2025 00:15:02

### DH1\_High

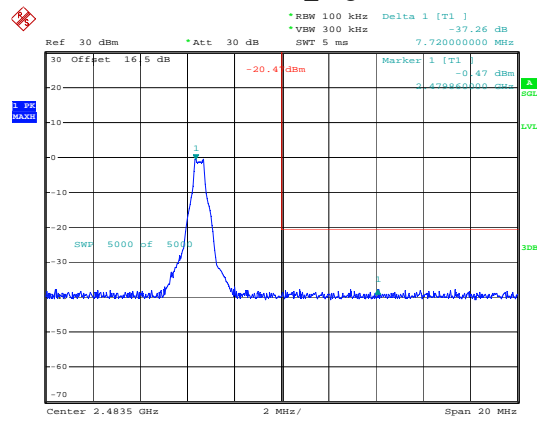

ProjectNo.:2502T01066E-RF Tester:Conor Fu  
Date: 12.JUN.2025 00:21:37

### DH1\_Hopping\_Lower

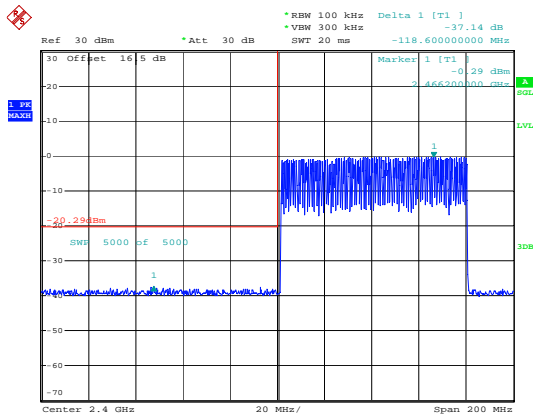

ProjectNo.:2502T01066E-RF Tester:Conor Fu  
Date: 12.JUN.2025 00:57:31

### DH1\_Hopping\_Upper

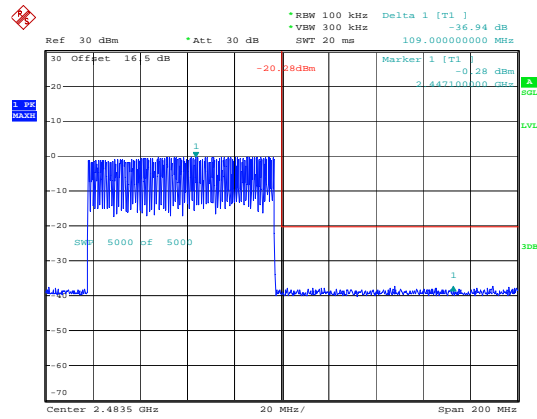

ProjectNo.:2502T01066E-RF Tester:Conor Fu  
Date: 12.JUN.2025 01:02:27

### 2DH1\_Low

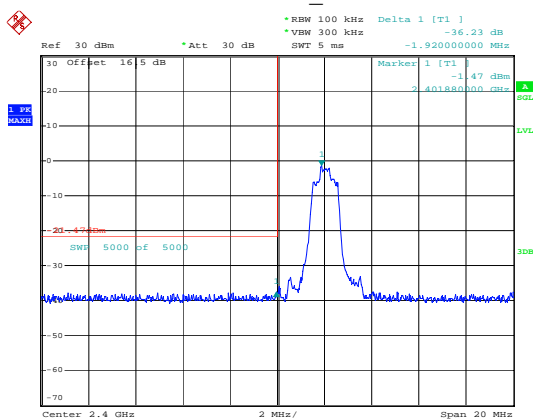

ProjectNo.:2502T01066E-RF Tester:Conor Fu  
Date: 12.JUN.2025 00:32:46

### 2DH1\_High

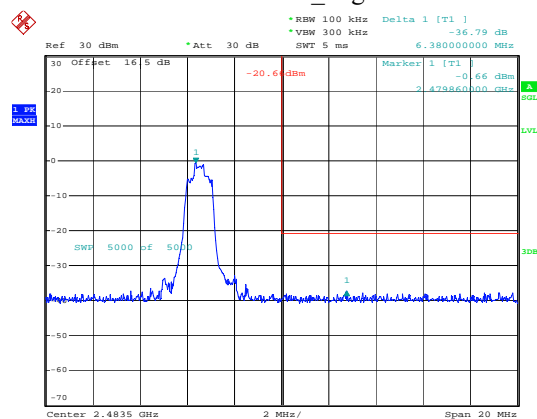

ProjectNo.:2502T01066E-RF Tester:Conor Fu  
Date: 12.JUN.2025 00:39:29

### 2DH1\_Hopping\_Lower

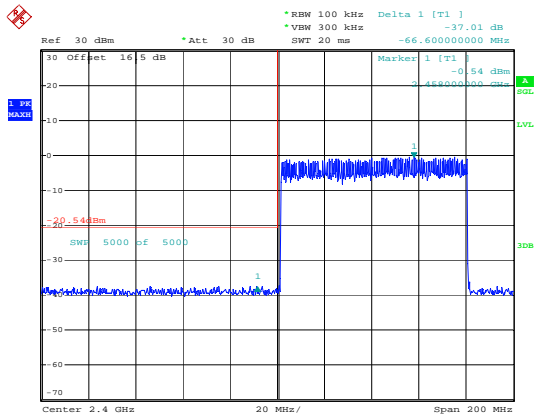

ProjectNo.:2502T01066E-RF Tester:Conor Fu  
Date: 12.JUN.2025 01:07:01

### 2DH1\_Hopping\_Upper

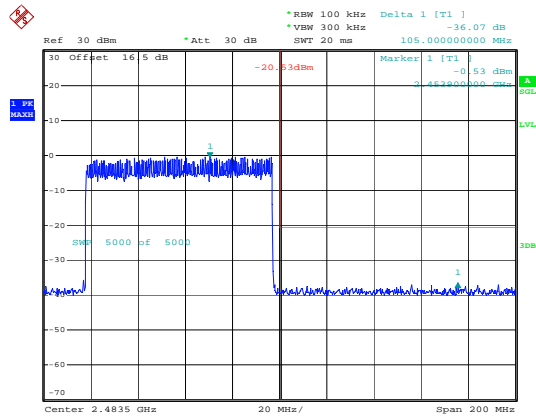

ProjectNo.:2502T01066E-RF Tester:Conor Fu  
Date: 12.JUN.2025 01:14:43

### 3DH1\_Low

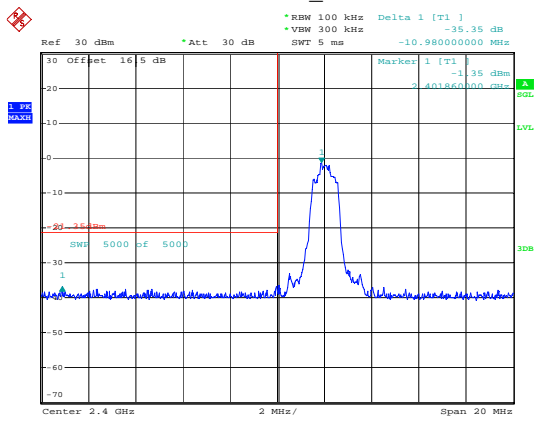

ProjectNo.:2502T01066E-RF Tester:Conor Fu  
Date: 12.JUN.2025 00:44:59

### 3DH1\_High

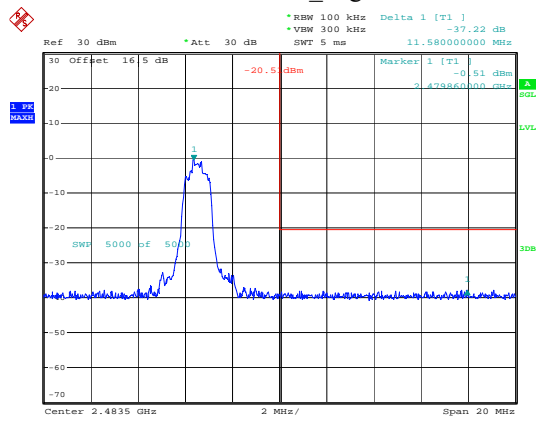

ProjectNo.:2502T01066E-RF Tester:Conor Fu  
Date: 12.JUN.2025 00:51:39

### 3DH1\_Hopping\_Lower

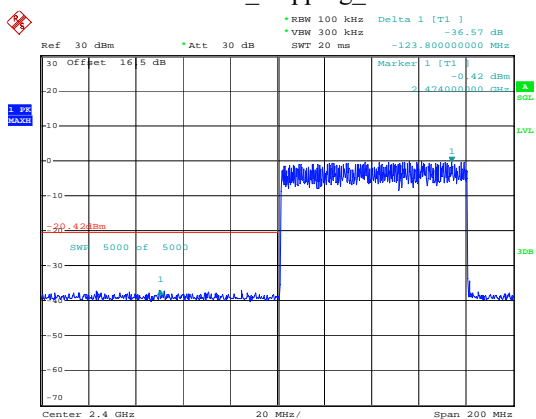

ProjectNo.:2502T01066E-RF Tester:Conor Fu  
Date: 12.JUN.2025 01:19:14

### 3DH1\_Hopping\_Upper

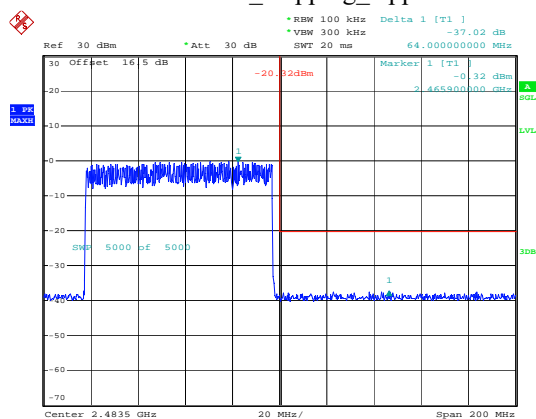

ProjectNo.:2502T01066E-RF Tester:Conor Fu  
Date: 12.JUN.2025 01:24:09



## **EXHIBIT A - EUT PHOTOGRAPHS**

---

Please refer to the attachment 2502T01066E-RF-EXP EUT EXTERNAL PHOTOGRAPHS and 2502T01066E-RF-INP EUT INTERNAL PHOTOGRAPHS.

---

## **EXHIBIT B - TEST SETUP PHOTOGRAPHS**

---

Please refer to the attachment 2502T01066E-RF-00A-TSP TEST SETUP PHOTOGRAPHS.

## EXHIBIT C - RF EXPOSURE EVALUATION

---

### Applicable Standard

According to §15.247(i) and §1.1310, systems operating under the provisions of this section shall be operated in a manner that ensure that the public is not exposed to radio frequency energy level in excess of the Commission's guideline.

According to KDB447498 D01 General RF Exposure Guidance v06:

The 1-g and 10-g SAR test exclusion thresholds for 100 MHz to 6 GHz at test separation distances  $\leq 50$  mm are determined by:

$[(\text{max. power of channel, including tune-up tolerance, mW})/(\text{min. test separation distance, mm})] \cdot [\sqrt{f(\text{GHz})}] \leq 3.0$  for 1-g SAR and  $\leq 7.5$  for 10-g extremity SAR, where

- $f(\text{GHz})$  is the RF channel transmit frequency in GHz
- Power and distance are rounded to the nearest mW and mm before calculation
- The result is rounded to one decimal place for comparison
- 3.0 and 7.5 are referred to as the numeric thresholds in the step 2 below

The test exclusions are applicable only when the minimum test separation distance is  $\leq 50$  mm and for transmission frequencies between 100 MHz and 6 GHz. When the minimum test separation distance is  $< 5$  mm, a distance of 5 mm according to 5) in section 4.1 is applied to determine SAR test exclusion.

### Measurement Result

The max conducted power including tune-up tolerance is 3.5 dBm (2.24 mW).

$[(\text{max. power of channel, mW})/(\text{min. test separation distance, mm})][\sqrt{f(\text{GHz})}]$   
 $= 2.24/5 \cdot (\sqrt{2.480}) = 0.7 < 3.0$

Note: the max conducted power including tune-up tolerance was declared by manufacturer.

**Result: Compliant. The stand-alone SAR evaluation is not necessary.**

**\*\*\*\*\* END OF REPORT \*\*\*\*\***