

FCC Test Report

FCC ID: 2ASJS-HR600

Product : MAGNUM SERIES

Trade Mark : N/A

Model Number : HR600

Prepared for

AXIS TECHNOLOGY

30 N GOULD ST, STE R, SHERIDAN, WY 82801, United States

Prepared by

Shenzhen NTEK Testing Technology Co., Ltd.

1/F, Building E, Fenda Science Park, Sanwei Community, Xixiang Street Bao'an
District, Shenzhen 518126 P.R. China

Tel.: +86-755-6115 6588 Fax.: +86-755-6115 6599

Website: <http://www.ntek.org.cn>

TEST RESULT CERTIFICATION

Applicant's Name : AXIS TECHNOLOGY
Address : 30 N GOULD ST, STE R, SHERIDAN, WY 82801, United States
Manufacturer's Name : AXIS TECHNOLOGY
Address : 30 N GOULD ST, STE R, SHERIDAN, WY 82801, United States

Product description

Product name : MAGNUM SERIES
Model and/or type reference : HR600

Standards : 47 CFR FCC part15 subpart B, 10-1-2018
ANSI C63.4:2014

This device described above has been tested by NTEK, and the test results show that the equipment under test (EUT) is in compliance with Part 15 of FCC Rules. And it is applicable only to the tested sample identified in the report.

This report shall not be reproduced except in full, without the written approval of NTEK, this document may be altered or revised by NTEK, personal only, and shall be noted in the revision of the document.

Date of Test :
Date (s) of performance of tests : Mar. 05, 2019 ~ Mar. 28, 2019
Date of Issue : 23 Apr. 2019
Test Result : Pass

Testing Engineer : [Signature: Cheng Jiawen]
(Cheng Jiawen)

Technical Manager : [Signature: Jason Chen]
(Jason Chen)

Authorized Signatory : [Signature: Sam Chen]
(Sam Chen)

Table of Contents	Page
1 . TEST SUMMARY	4
1.1 TEST FACILITY	5
1.2 MEASUREMENT UNCERTAINTY	5
2 . GENERAL INFORMATION	7
2.1 GENERAL DESCRIPTION OF EUT	7
2.2 DESCRIPTION OF TEST MODES	8
2.3 DESCRIPTION OF TEST SETUP	9
2.4 DESCRIPTION TEST PERIPHERAL AND EUT PERIPHERAL	10
2.5 MEASUREMENT INSTRUMENTS LIST	11
3 . EMC EMISSION TEST	12
3.1 CONDUCTED EMISSION MEASUREMENT	12
3.1.1 POWER LINE CONDUCTED EMISSION	12
3.1.2 TEST PROCEDURE	13
3.1.3 TEST SETUP	13
3.1.4 EUT OPERATING CONDITIONS	13
3.1.5 TEST RESULTS	14
3.2 RADIATED EMISSION MEASUREMENT	16
3.2.1 LIMITS OF RADIATED EMISSION MEASUREMENT	16
3.2.2 TEST PROCEDURE	16
3.2.3 TEST SETUP	17
3.2.4 EUT OPERATING CONDITIONS	17
3.2.5 TEST RESULTS(30-1000MHz)	18
3.2.6 TEST RESULTS(Above 1000MHz)	20

1. TEST SUMMARY

Test procedures according to the technical standards:

EMC Emission				
Standard	Test Item	Limit	Judgment	Remark
FCC part15 subpart B, 10-1-2018 ANSI C63.4: 2014	Conducted Emission	Class B	PASS	
	Radiated Emission	Class B	PASS	

NOTE:

- (1) 'N/A' denotes test is not applicable in this Test Report
- (2) For client's request and manual description, the test will not be executed.

1.1 TEST FACILITY

Shenzhen NTEK Testing Technology Co., Ltd.

Add. : 1/F, Building E, Fenda Science Park, Sanwei Community, Xixiang Street Bao'an District, Shenzhen 518126 P.R. China

CNAS-Lab. : The Laboratory has been assessed and proved to be in compliance with CNAS-CL01:2006 (identical to ISO/IEC 17025:2005)
The Certificate Registration Number is L5516

IC-Registration : The Certificate Registration Number is 9270A-1

FCC- Accredited : Test Firm Registration Number: 463705
Designation Number: CN1184

A2LA-Lab. : The Certificate Registration Number is 4298.01
This laboratory is accredited in accordance with the recognized International Standard ISO/IEC 17025:2005 General requirements for the competence of testing and calibration laboratories.
This accreditation demonstrates technical competence for a defined scope and the operation of a laboratory quality management system (refer to joint ISO-ILAC-IAF Communiqué dated 8 January 2009).

1.2 MEASUREMENT UNCERTAINTY

The reported uncertainty of measurement $y \pm U$, where expanded uncertainty U is based on a standard uncertainty multiplied by a coverage factor of $k=2$, providing a level of confidence of approximately **95** %.

Test Item	Measurement Frequency Range	K	U(dB)
AC Mains Conducted Emission	0.009kHz ~ 0.15MHz	2	2.66
AC Mains Conducted Emission	0.15MHz ~ 30MHz	2	2.80
Telecom Conducted Emission (Cat 3)	0.15MHz ~ 30MHz	2	2.40
Telecom Conducted Emission (Cat 5)	0.15MHz ~ 30MHz	2	2.58
Radiated Emission	30MHz ~ 1000MHz	2	2.64
Radiated Emission	1000MHz ~ 6000MHz	2	2.40
Radiated Emission	6000MHz ~ 18000MHz	2	2.52
Power Clamp	30MHz ~ 300MHz	2	2.20

Revision History

Report No.	Version	Description	Issued Date
S19030404202005	Rev.01	Initial issue of report	Apr 23, 2019

2. GENERAL INFORMATION

2.1 GENERAL DESCRIPTION OF EUT

Equipment	MAGNUM SERIES	
Model Name	HR600	
Additional Model Number(s)	N/A	
Model Difference	N/A	
Product Description	The EUT is a MAGNUM SERIES.	
	Operating frequency:	1.3GHz (Declaration by factory)
	Connecting I/O port:	N/A
Power supply	Based on the application, features, or specification exhibited in User's Manual. More details of EUT technical specification, please refer to the User's Manual.	
	<input checked="" type="checkbox"/> DC supply: DC 3.7V/3100mAh from Battery or DC 5V from USB Port.	
	<input checked="" type="checkbox"/> Adapter supply: Model: NO:N-01 Input: 100-240V~50/60Hz Output: 5V $\overline{\text{---}}$ 1A Max	
HW Version	V130F_MB_V1.1_20180125	
SW Version	ALPS.L1.MP6.V2.19_HCT6580.WEG.A.L_P55	

2.2 DESCRIPTION OF TEST MODES

To investigate the maximum EMI emission characteristics generates from EUT, the test system was pre-scanning tested base on the consideration of following EUT operation mode or test configuration mode which possible have effect on EMI emission level. Each of these EUT operation mode(s) or test configuration mode(s) mentioned above was evaluated respectively.

All test modes in the table below are tested, the worst case is listed on this report.

Pretest Mode	Description
Mode 1	USB Data Transmission
Mode 2	Charging + REC
Mode 3	Charging + TF Playing
Mode 4	Charging + FM(87.5MHz / 98MHz / 108MHz)

For Conducted Test	
Final Test Mode	Description
Mode 1	USB Data Transmission
Mode 2	Charging + REC
Mode 3	Charging + TF Playing
Mode 4	Charging + FM(87.5MHz / 98MHz / 108MHz)

For Radiated Test	
Final Test Mode	Description
Mode 1	USB Data Transmission
Mode 2	Charging + REC
Mode 3	Charging + TF Playing
Mode 4	Charging + FM(87.5MHz / 98MHz / 108MHz)

2.3 DESCRIPTION OF TEST SETUP

Mode CE : Data Transmission

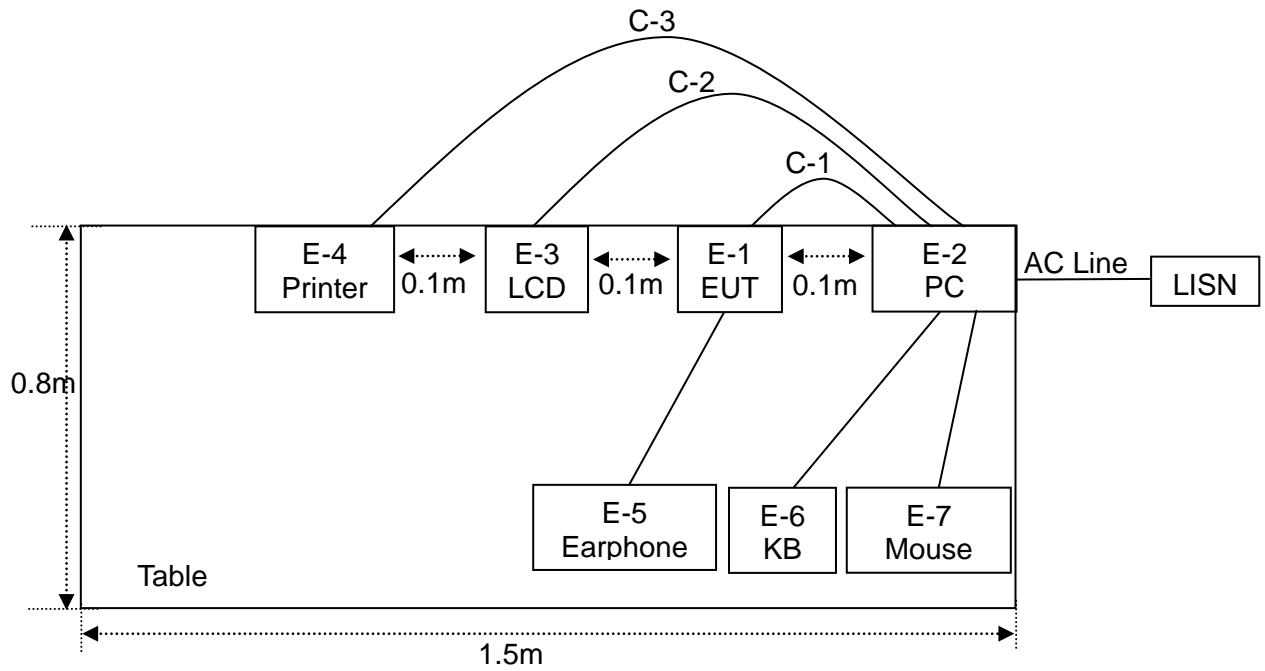

2.4 DESCRIPTION TEST PERIPHERAL AND EUT PERIPHERAL

The EUT has been tested as an independent unit together with other necessary accessories or support units. The following support units or accessories were used to form a representative test configuration during the tests.

Item	Equipment	Brand	Model/Type No.	Series No.	Note
E-1	MAGNUM SERIES	N/A	HR600	N/A	EUT
E-2	PC	DELL	D06S	34531671097	
E-3	LCD	SHARP	LCD-32MS46A	09426089241597	
E-4	Printer	Canon	L11121E	LBP2900	
E-5	Earphone	N/A	N/A	N/A	
E-6	Keyboard	Logi	Y-U0011	820-003405 SY109UK	
E-7	Mouse	HP	MS-SBF96	417441-002REV.O C	

Item	Shielded Type	Ferrite Core	Length	Note
C-1	YES	NO	80cm	
C-2	YES	YES	120cm	
C-3	YES	YES	120cm	

Note:

- (1) The support equipment was authorized by Declaration of Confirmation.
- (2) For detachable type I/O cable should be specified the length in cm in 『Length』 column.
- (3) “YES” means “shielded” “with core”; “NO” means “unshielded” “without core”.

2.5 MEASUREMENT INSTRUMENTS LIST

2.5.1 CONDUCTED TEST SITE

Item	Kind of Equipment	Manufacturer	Type No.	Serial No.	Last calibration	Calibrated until	Calibration period
1	Low frequency cable	N/A	C-01	N/A	Jun. 06, 2017	Jun. 05, 2020	3 years
2	50Ω Switch	Anritsu	MP59B	6200983704	May 19, 2018	May 18, 2020	2 years
3	LISN	SCHWARZB ECK	NNLK 8129	8129245	May 19, 2018	May 18, 2019	1 year
4	EMI Test Receiver	R&S	ESCI	101160	May 19, 2018	May 18, 2019	1 year
5	LISN	R&S	ENV216	101313	Apr. 09, 2018	Apr. 08, 2019	1 year
6	LISN	R&S	ENV216	101490	Oct. 08, 2018	Oct. 07, 2019	1 year

2.5.2 RADIATED TEST SITE

Item	Kind of Equipment	Manufacturer	Type No.	Serial No.	Last calibration	Calibrated until	Calibration period
1	Antenna Mast	SKET	N/A	N/A	N/A	N/A	N/A
2	Antenna Mast	EM	SC100	N/A	Apr. 26, 2017	Apr. 25, 2020	3 years
3	50Ω Switch	Anritsu	MP59B	6200983705	May 19, 2018	May 18, 2020	2 years
4	Test Cable	N/A	R-01	N/A	Aug. 08, 2016	Aug. 07, 2019	3 years
5	Pre-Amplifier	EMC	EMC051835S E	980246	Aug. 05, 2018	Aug. 04, 2019	1 year
6	Test Cable	N/A	R-03	N/A	Jun. 26, 2016	Jun. 25, 2019	3 years
7	EMI Test Receiver	R&S	ESCI	101160	May 19, 2018	May 18, 2019	1 year
8	Bilog Antenna	TESEQ	CBL6111D	31216	Apr. 08, 2018	Apr. 07, 2019	1 year
9	Broadband Horn Antenna	EM	EM-AH-10180	2011071402	Apr. 08, 2018	Apr. 07, 2019	1 year
10	Spectrum Analyzer	Agilent	E4440A	MY41000130	Mar. 28, 2018	Mar. 28, 2019	1 year

3. EMC EMISSION TEST

3.1 CONDUCTED EMISSION MEASUREMENT

3.1.1 POWER LINE CONDUCTED EMISSION (Frequency Range 150kHz-30MHz)

FREQUENCY (MHz)	<input type="checkbox"/> Class A (dB μ V)		<input checked="" type="checkbox"/> Class B (dB μ V)	
	Quasi-peak	Average	Quas -peak	Average
0.15 -0.5	79.00	66.00	66 - 56 *	56 - 46 *
0.50 -5.0	73.00	60.00	56.00	46.00
5.0 -30.0	73.00	60.00	60.00	50.00

Note:

- (1) The tighter limit applies at the band edges.
- (2) The limit of " * " marked band means the limitation decreases linearly with the logarithm of the frequency in the range.

The following table is the setting of the receiver

Receiver Parameters	Setting
Attenuation	10 dB
Start Frequency	0.15 MHz
Stop Frequency	30 MHz
IF Bandwidth	9 kHz

3.1.2 TEST PROCEDURE

- a. The EUT was placed 0.8 meters from the horizontal ground plane with EUT being connected to the power mains through a line impedance stabilization network (LISN). All other support equipments powered from additional LISN(s). The LISN provide 50 Ohm/ 50uH of coupling impedance for the measuring instrument.
- b. Interconnecting cables that hang closer than 40 cm to the ground plane shall be folded back and forth in the center forming a bundle 30 to 40 cm long.
- c. I/O cables that are not connected to a peripheral shall be bundled in the center. The end of The cable may be terminated, if required, using the correct terminating impedance. The overall length shall not exceed 1 m.
- d. LISN at least 80 cm from nearest part of EUT chassis.
- e. For the actual test configuration, please refer to the related Item –EUT Test Photos.

3.1.3 TEST SETUP

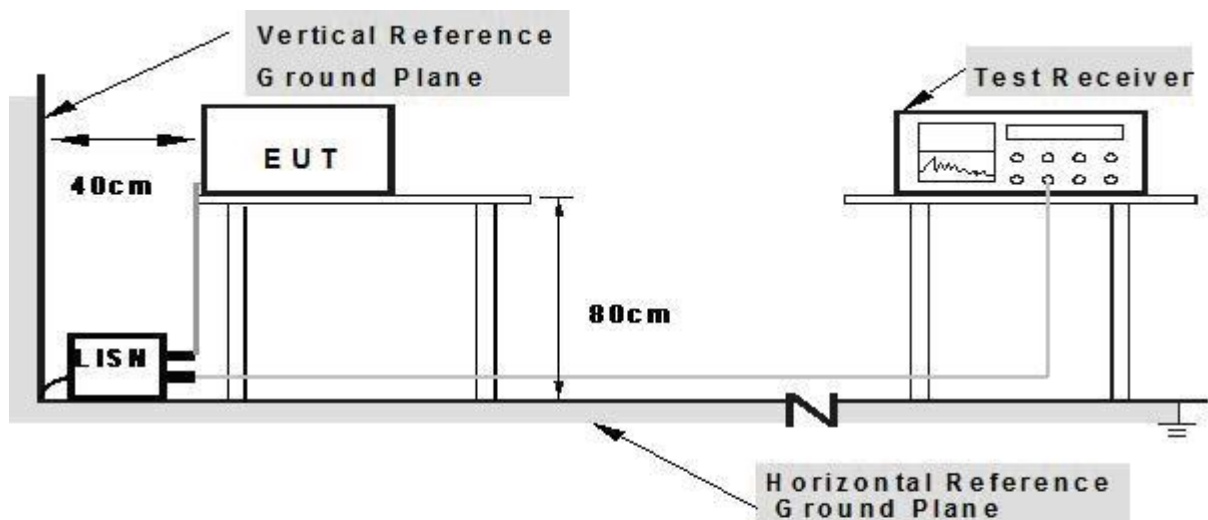

Note: 1.Support units were connected to second LISN.

2.Both of LISNs (AMN) are 80 cm from EUT and at least 80 from other units and other metal planes

3.1.4 EUT OPERATING CONDITIONS

The EUT tested system was configured as the statements of 2.3 Unless otherwise a special operating condition is specified in the follows during the testing.

3.1.5 TEST RESULTS

EUT:	MAGNUM SERIES	Model Name. :	HR600
Temperature:	20°C	Relative Humidity:	56%
Pressure:	1010hPa	Test Date :	2019-03-25
Test Mode:	USB Data Transmission	Phase:	L
Test Voltage:	DC 5V powered by PC		

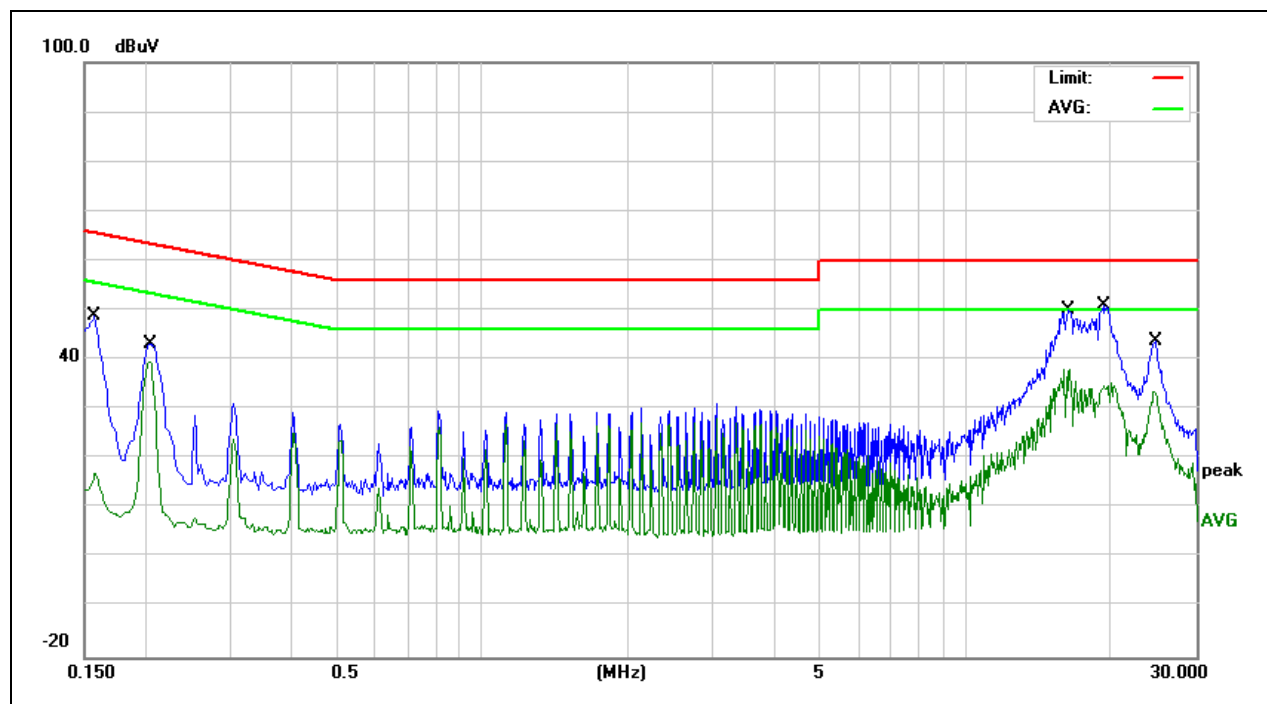

No.	Frequency (MHz)	Reading (dBuV)	Correct dB	Result (dBuV)	Limit (dBuV)	Over Limit (dB)	Remark
1	0.1580	39.02	9.75	48.77	65.56	-16.79	QP
2	0.1580	7.43	9.75	17.18	55.56	-38.38	AVG
3	0.2060	33.49	9.76	43.25	63.36	-20.11	QP
4	0.2060	29.93	9.76	39.69	53.36	-13.67	AVG
5	16.3499	39.89	10.14	50.03	60.00	-9.97	QP
6	16.3499	27.98	10.14	38.12	50.00	-11.88	AVG
7	19.2979	40.88	10.21	51.09	60.00	-8.91	QP
8	19.2979	25.24	10.21	35.45	50.00	-14.55	AVG
9	24.7820	33.07	10.70	43.77	60.00	-16.23	QP
10	24.7820	22.94	10.70	33.64	50.00	-16.36	AVG

Remark:
 Correct Factor = Insertion Loss + Cable Loss
 Measurement Level = Reading Level + Correct Factor
 Over Level = Measurement Level - Limit

EUT:	MAGNUM SERIES	Model Name. :	HR600
Temperature:	20°C	Relative Humidity:	56%
Pressure:	1010hPa	Test Date :	2019-03-25
Test Mode:	USB Data Transmission	Phase:	N
Test Voltage:	DC 5V powered by PC		

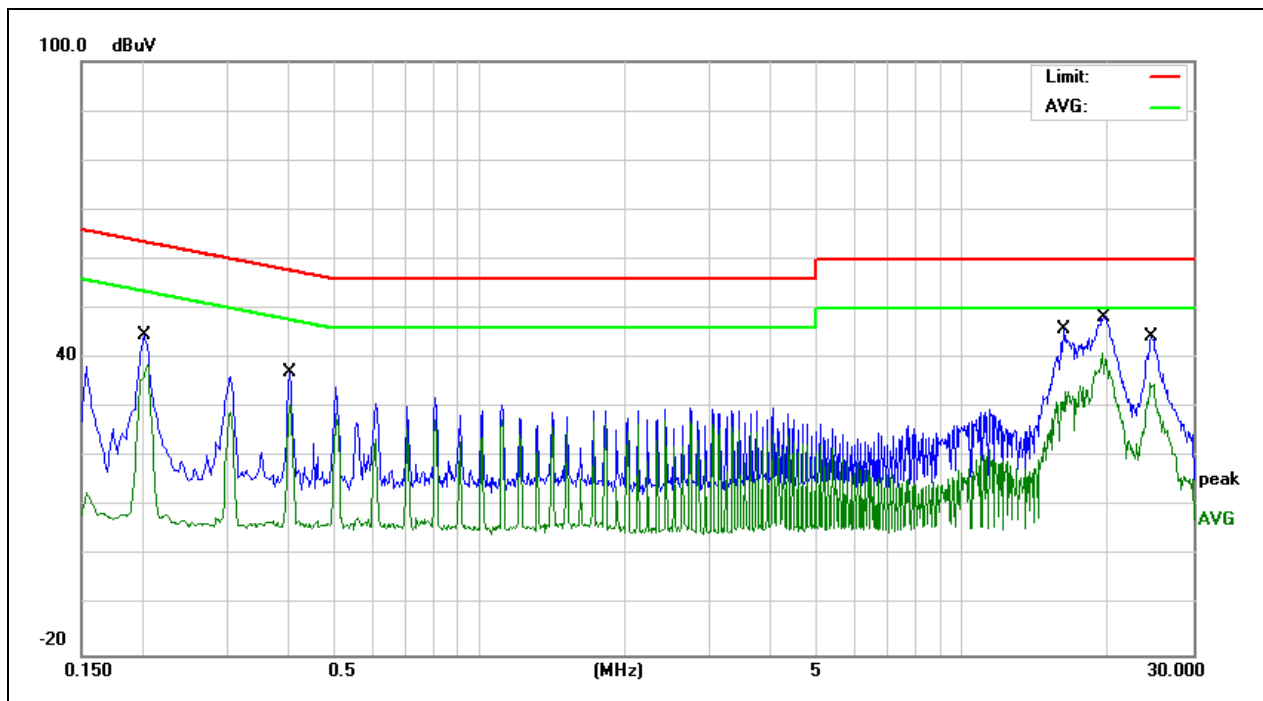

No.	Frequency (MHz)	Reading (dBuV)	Correct dB	Result (dBuV)	Limit (dBuV)	Over Limit (dB)	Remark
1	0.2020	34.98	9.73	44.71	63.52	-18.81	QP
2	0.2020	29.03	9.73	38.76	53.52	-14.76	AVG
3	0.4060	27.36	9.75	37.11	57.73	-20.62	QP
4	0.4060	20.71	9.75	30.46	47.73	-17.27	AVG
5	16.1939	35.74	10.11	45.85	60.00	-14.15	QP
6	16.1939	23.25	10.11	33.36	50.00	-16.64	AVG
7	19.5379	38.08	10.20	48.28	60.00	-11.72	QP
8	19.5379	30.74	10.20	40.94	50.00	-9.06	AVG
9	24.5980	33.58	10.63	44.21	60.00	-15.79	QP
10	24.5980	24.46	10.63	35.09	50.00	-14.91	AVG

Remark:
 Correct Factor = Insertion Loss + Cable Loss
 Measurement Level = Reading Level + Correct Factor
 Over Level = Measurement Level - Limit

3.2 RADIATED EMISSION MEASUREMENT

3.2.1 LIMITS OF RADIATED EMISSION MEASUREMENT

FREQUENCY (MHz)	<input type="checkbox"/> Class A (at 3m)	<input checked="" type="checkbox"/> Class B (at 3m)
	dBµV/m	
30 ~ 88	49.5	40.0
88 ~ 216	53.9	43.5
216 ~ 960	56.9	46.0
Above 960	60.0	54.0

Notes:

- (1) The limit for radiated test was performed according to as following: FCC PART 15B.
- (2) The tighter limit applies at the band edges.
- (3) Emission level (dBµV/m)=20log Emission level (uV/m).

3.2.2 TEST PROCEDURE

- a. The measuring distance of at 3m shall be used for measurements at frequency up to 1GHz. For frequencies above 1GHz, any suitable measuring distance may be used.
- b. The EUT was placed on the top of a rotating table 0.8 meters above the ground at a 3 meter open area test site. The table was rotated 360 degrees to determine the position of the highest radiation.
- c. The height of the equipment or of the substitution antenna shall be 0.8 m; the height of the test antenna shall vary between 1 m to 4 m. Both horizontal and vertical polarizations of the antenna are set to make the measurement.
- d. The initial step in collecting conducted emission data is a spectrum analyzer peak detector mode pre-scanning the measurement frequency range. Significant peaks are then marked And then Quasi Peak detector mode re-measured, above 1G Average detector mode will be instead.
- e. If the Peak Mode measured value compliance with and lower than Quasi Peak Mode Limit, the EUT shall be deemed to meet QP(AV) Limits and then no additional QP Mode measurement performed.
- f. For the actual test configuration, please refer to the related Item –EUT Test Photos.

3.2.3 TEST SETUP

(A) Radiated Emission Test Set-Up Frequency Below 1 GHz

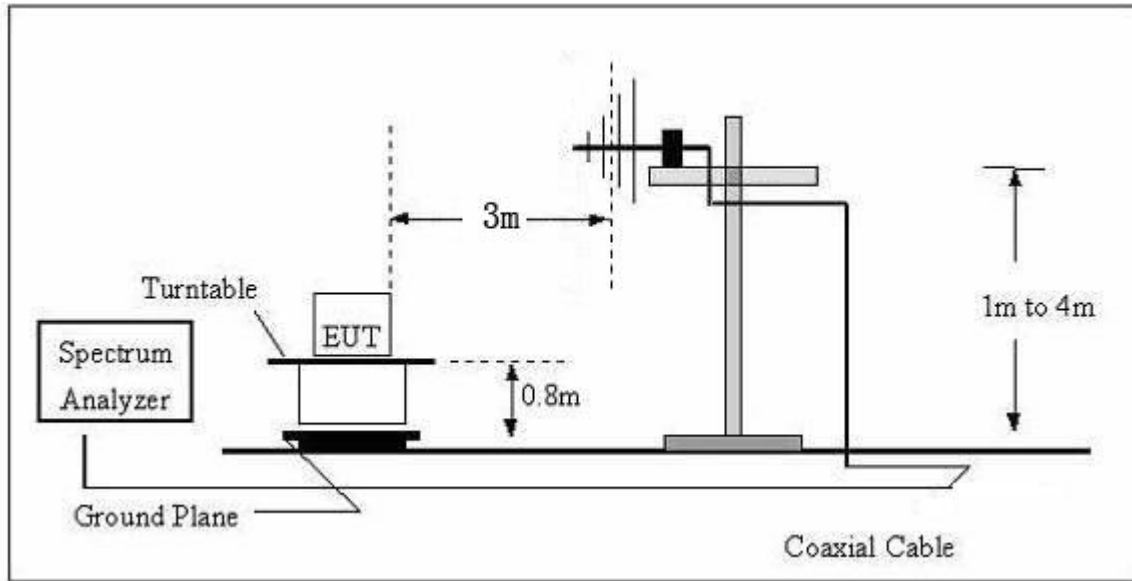

(B) Radiated Emission Test Set-Up Frequency Above 1GHz

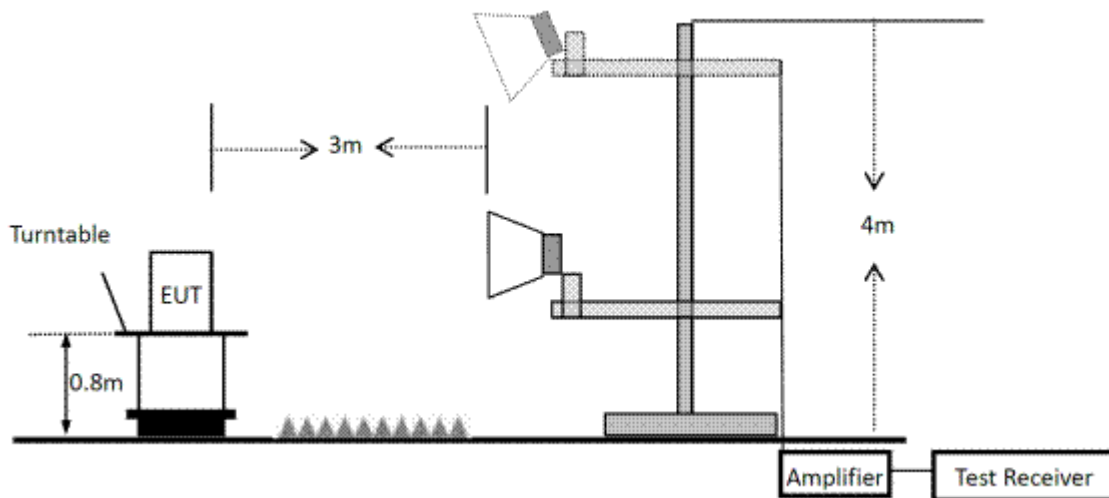

3.2.4 EUT OPERATING CONDITIONS

The EUT tested system was configured as the statements of 2.3 Unless otherwise a special operating condition is specified in the follows during the testing.

3.2.5 TEST RESULTS(30-1000MHz)

EUT:	MAGNUM SERIES	Model Name :	HR600
Temperature:	24°C	Relative Humidity:	45%
Pressure:	1010hPa	Test Date :	2019-03-25
Test Mode:	USB Data Transmission	Polarization:	Horizontal
Test Power:	DC 5V powered by PC		

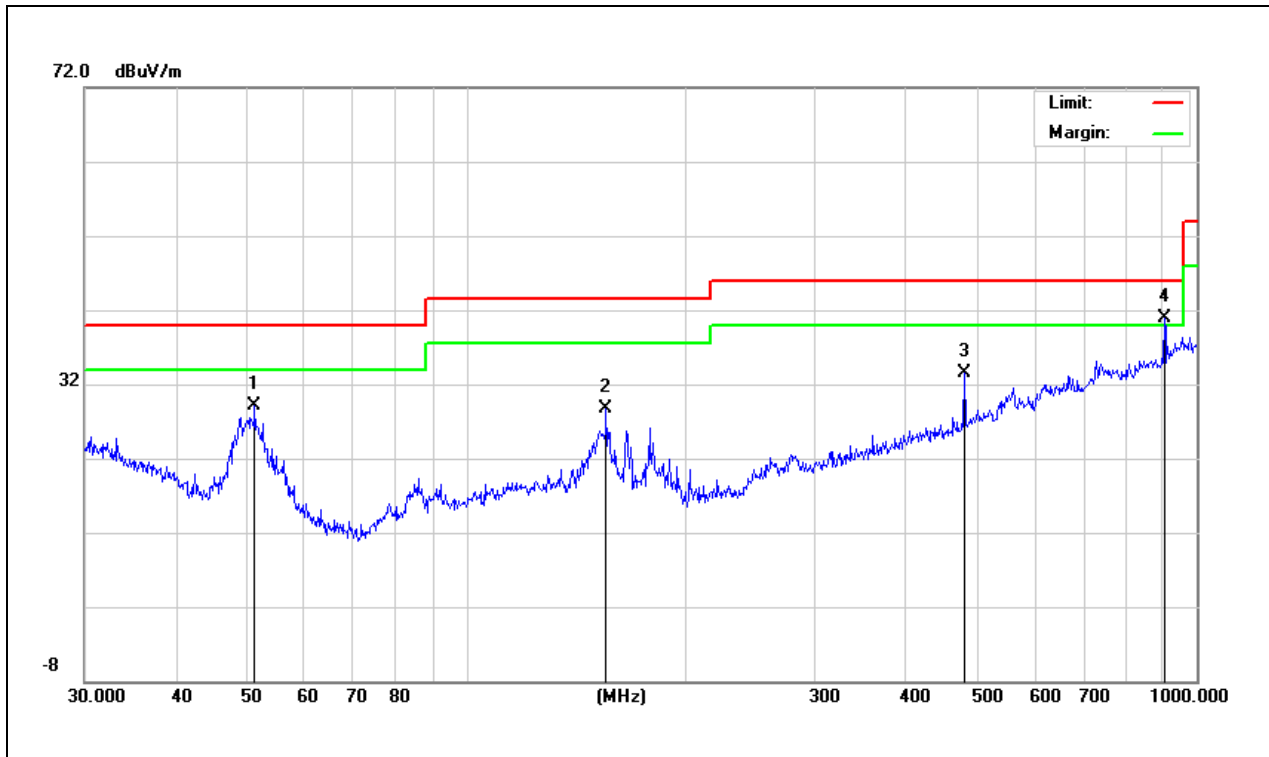

No.	Frequency (MHz)	Reading (dBuV/m)	Correct dB/m	Result (dBuV/m)	Limit (dBuV/m)	Over Limit (dB)	Remark
1	51.3005	20.73	8.39	29.12	40.00	-10.88	QP
2	155.3644	16.29	12.45	28.74	43.50	-14.76	QP
3	480.5276	12.15	21.41	33.56	46.00	-12.44	QP
4	903.3094	11.76	29.12	40.88	46.00	-5.12	QP

Remark:

Correct Factor = Antenna Factor + Cable Loss – Pre-Amplifier gain

Measurement Level = Reading Level + Correct Factor

Over Level = Measurement Level - Limit

EUT:	MAGNUM SERIES	Model Name :	HR600
Temperature:	24°C	Relative Humidity:	45%
Pressure:	1010hPa	Test Date :	2019-03-25
Test Mode:	USB Data Transmission	Polarization:	Vertical
Test Power:	DC 5V powered by PC		

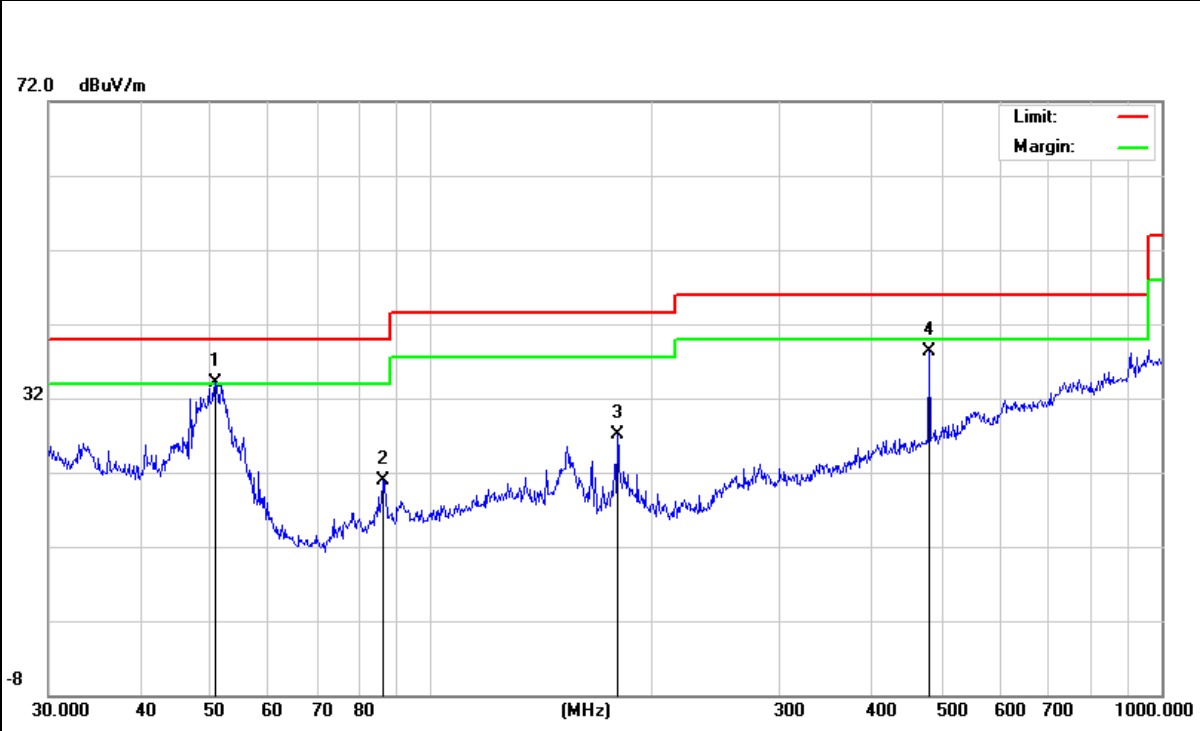

No.	Frequency (MHz)	Reading (dBuV/m)	Correct dB/m	Result (dBuV/m)	Limit (dBuV/m)	Over Limit (dB)	Remark
1	50.7637	25.46	8.73	34.19	40.00	-5.81	QP
2	86.2001	10.91	10.03	20.94	40.00	-19.06	QP
3	180.0165	16.24	10.84	27.08	43.50	-16.42	QP
4	480.5276	16.94	21.41	38.35	46.00	-7.65	QP

Remark:
 Correct Factor = Antenna Factor + Cable Loss – Pre-Amplifier gain
 Measurement Level = Reading Level + Correct Factor
 Over Level = Measurement Level - Limit

3.2.6 TEST RESULTS(Above 1000MHz)

EUT:	MAGNUM SERIES	Model Name :	HR600
Temperature:	24°C	Relative Humidity:	45%
Pressure:	1010hPa	Test Date :	2019-03-25
Test Mode:	USB Data Transmission	Polarization:	Horizontal
Test Power:	DC 5V powered by PC		

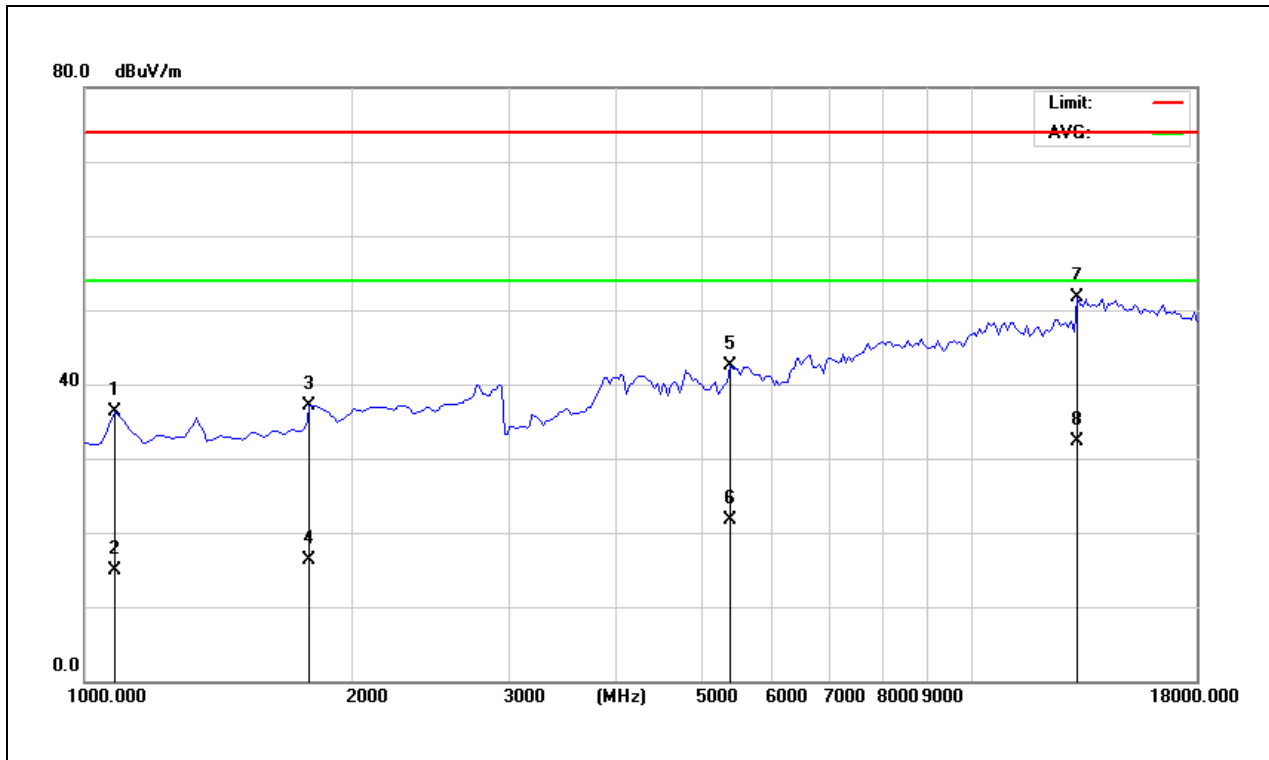

No.	Frequency (MHz)	Reading (dBuV/m)	Correct dB/m	Result (dBuV/m)	Limit (dBuV/m)	Over Limit (dB)	Remark
1	1085.000	46.76	-10.48	36.28	74.00	-37.72	peak
2	1085.000	25.47	-10.48	14.99	54.00	-39.01	AVG
3	1807.500	44.48	-7.30	37.18	74.00	-36.82	peak
4	1807.500	23.58	-7.30	16.28	54.00	-37.72	AVG
5	5377.500	35.44	7.03	42.47	74.00	-31.53	peak
6	5377.500	14.72	7.03	21.75	54.00	-32.25	AVG
7	13282.500	-9.10	60.85	51.75	74.00	-22.25	peak
8	13282.500	-28.49	60.85	32.36	54.00	-21.64	AVG

Remark:
 Correct Factor = Antenna Factor + Cable Loss – Pre-Amplifier gain
 Measurement Level = Reading Level + Correct Factor
 Over Level = Measurement Level - Limit

EUT:	MAGNUM SERIES	Model Name :	HR600
Temperature:	24°C	Relative Humidity:	45%
Pressure:	1010hPa	Test Date :	2019-03-25
Test Mode:	USB Data Transmission	Polarization:	Vertical
Test Power:	DC 5V powered by PC		

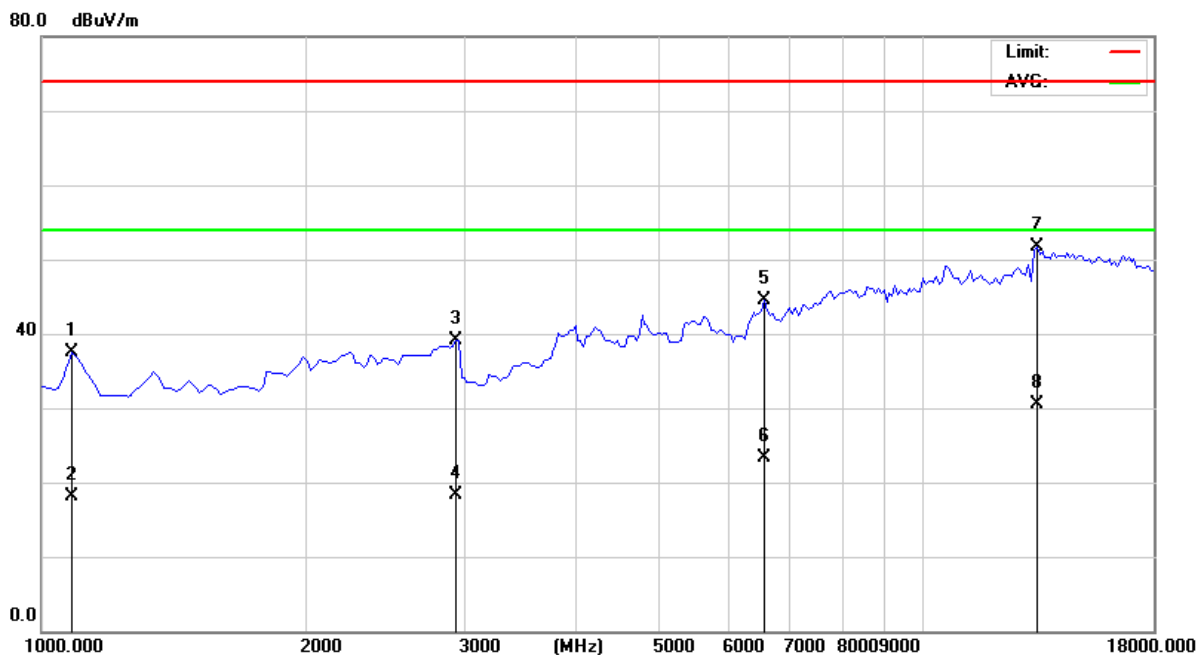

No.	Frequency (MHz)	Reading (dBuV/m)	Correct dB/m	Result (dBuV/m)	Limit (dBuV/m)	Over Limit (dB)	Remark
1	1085.000	47.97	-10.48	37.49	74.00	-36.51	peak
2	1085.000	28.63	-10.48	18.15	54.00	-35.85	AVG
3	2955.000	41.62	-2.45	39.17	74.00	-34.83	peak
4	2955.000	20.77	-2.45	18.32	54.00	-35.68	AVG
5	6567.500	-5.38	49.80	44.42	74.00	-29.58	peak
6	6567.500	-26.54	49.80	23.26	54.00	-30.74	AVG
7	13325.000	-9.23	60.88	51.65	74.00	-22.35	peak
8	13325.000	-30.34	60.88	30.54	54.00	-23.46	AVG

Remark:

Correct Factor = Antenna Factor + Cable Loss – Pre-Amplifier gain

Measurement Level = Reading Level + Correct Factor

Over Level = Measurement Level - Limit