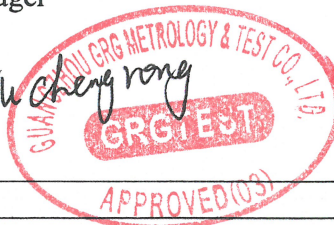

# TEST REPORT

Verified Code:369174

<b>Report No.:</b>	E202008101990-9	<b>Application No.:</b>	E202008101990
<b>Client:</b>	BY TECHDESIGN S.L.		
<b>Address:</b>	Calle Thomas Edison 5, Arganda del Rey Madrid, 28500, Spain		
<b>Sample Description:</b>	Access Control System - RF readers		
<b>Model:</b>	42492		
<b>Test Specification:</b>	FCC 47 CFR Part 15 Subpart C		
<b>Receipt Date:</b>	2020-08-12		
<b>Test Date:</b>	2020-09-08 to 2020-09-08		
<b>Issue Date:</b>	2020-12-21		
<b>Test Result:</b>	Pass		
<b>Prepared By:</b> Test Engineer	<b>Reviewed By:</b> Technical Manager	<b>Approved By:</b> Manager	
<i>Xie Jiang</i>	<i>Wu Hawthry</i>	<i>Wu Chengrong</i>	
			
<b>Other Aspects:</b>			
Note: Note			
Abbreviations: ok / P = passed; fail / F = failed; n.a. / N = not applicable;			
The test result in this test report refers exclusively to the presented test sample. This report shall not be reproduced except in full, without the written approval of GRGT.			

## **DIRECTIONS OF TEST**

- 1. This station carries out test task according to the national regulation of verifications which can be traced to National Primary Standards and BIPM.**
- 2. The test report merely corresponds to the test sample. It is not permitted to copy extracts of these test result without the written permission of the test laboratory.**
- 3. If there is any objection concerning the test, the client should inform the laboratory within 15 days from the date of receiving the test report.**

## TABLE OF CONTENTS

<b>1. TEST RESULT SUMMARY.....</b>	<b>4</b>
<b>2. GENERAL DESCRIPTION OF EUT .....</b>	<b>5</b>
2.1. APPLICANT .....	5
2.2. MANUFACTURER .....	5
2.3. FACTORY .....	5
2.4. BASIC DESCRIPTION OF EQUIPMENT UNDER TEST .....	5
2.5. TEST OPERATION MODE .....	6
2.6. LOCAL SUPPORTIVE.....	6
<b>3. LABORATORY AND ACCREDITATIONS .....</b>	<b>7</b>
3.1. LABORATORY .....	7
3.2. ACCREDITATIONS .....	7
3.3. MEASUREMENT UNCERTAINTY .....	7
<b>4. LIST OF USED TEST EQUIPMENT AT GRGT .....</b>	<b>8</b>
<b>5. CONDUCTED EMISSION MEASUREMENT.....</b>	<b>9</b>
5.1. LIMITS.....	9
5.2. TEST PROCEDURES.....	9
5.3. TEST SETUP .....	10
5.4. DATA SAMPLE .....	10
5.5. TEST RESULTS .....	11
<b>6. RADIATED SPURIOUS EMISSIONS .....</b>	<b>13</b>
6.1. LIMITS.....	13
6.2. TEST PROCEDURES (PLEASE REFER TO MEASUREMENT STANDARD).....	13
6.3. TEST SETUP .....	17
6.4. DATA SAMPLE .....	18
6.5. TEST RESULTS .....	19
<b>7. 6DB BANDWIDTH.....</b>	<b>28</b>
7.1. LIMITS.....	28
7.2. TEST PROCEDURES.....	28
7.3. TEST SETUP .....	28
7.4. TEST RESULTS .....	29
<b>8. MAXIMUM PEAK OUTPUT POWER .....</b>	<b>31</b>
8.1. LIMITS.....	31
8.2. TEST PROCEDURES.....	31
8.3. TEST SETUP .....	31
8.4. TEST RESULTS .....	31
<b>9. POWER SPECTRAL DENSITY .....</b>	<b>32</b>
9.1. LIMITS.....	32
9.2. TEST PROCEDURES.....	32
9.3. TEST SETUP .....	32
9.4. TEST RESULTS .....	33
<b>10. CONDUCTED BAND EDGES AND SPURIOUS EMISSIONS.....</b>	<b>35</b>
10.1. LIMITS.....	35
10.2. TEST PROCEDURES.....	35
10.3. TEST SETUP .....	35
10.4. TEST RESULTS .....	36
<b>11. RESTRICTED BANDS OF OPERATION.....</b>	<b>39</b>
11.1. LIMITS.....	39
11.2. TEST PROCEDURES.....	39

11.3.	TEST SETUP .....	40
11.4.	TEST RESULTS .....	41

## 1. TEST RESULT SUMMARY

<b>Technical Requirements</b>		
FCC Part 15 Subpart C KDB 558074 D01: DTS measurement guidance v0502		
<b>Limit / Severity</b>	<b>Item</b>	<b>Result</b>
§15.207	Conducted emission AC power port	Pass
§15.247(b)(1)	Conducted output power for FHSS	N/A
§15.247(b)(3)	Conducted output power for DTS	Pass
§15.247(e)	Power spectral density	Pass
§15.247(a)(2)	6dB bandwidth	Pass
§15.247(a)(1)	20dB Occupied bandwidth	N/A
--	99% Occupied Bandwidth	N/A
§15.247(a)(1)	Carrier frequency separation	N/A
§15.247(a)(1)(iii)	Number of hopping frequencies	N/A
§15.247(a)(1)(iii)	Dwell Time	N/A
§15.247(d)	Spurious RF conducted emissions	Pass
§15.247(d)	Band edge	Pass
§15.247(d) & §15.209 & §15.205	Spurious radiated emissions for transmitter	Pass
§15.203	Antenna requirement	Pass

The EUT has one antenna. The antenna is internal antenna.

The max gain of antenna is 2.5dBi.which accordance 15.203.is considered sufficient to comply with the provisions of this section.

## 2. GENERAL DESCRIPTION OF EUT

### 2.1. APPLICANT

Name: BY TECHDESIGN S.L.  
Address: Calle Thomas Edison 5, Arganda del Rey Madrid, 28500, Spain

### 2.2. MANUFACTURER

Name: BY TECHDESIGN S.L.  
Address: Calle Thomas Edison 5, Arganda del Rey Madrid, 28500, Spain

### 2.3. FACTORY

Name : BY TECHDESIGN S.L.  
Address : Calle Thomas Edison 5, Arganda del Rey Madrid, 28500, Spain

### 2.4. BASIC DESCRIPTION OF EQUIPMENT UNDER TEST

Equipment: Access Control System - RF readers  
Model No.: 42492  
Adding Model: 42493, 42534, 42535, 42536, 42540

Model	Type	Power supply and input /output	Difference
Differences:	Polo	SDU or SUD+ for NÜO Polo: Input: 24VDC, 2.0W	All models are same included the hardware and software, except of the exterior's color and the model name.

Trade Name:



FCC ID: 2ARQ3-MTA42492  
Power supply: SDU or SUD+ for NÜO Polo: Input: 24VDC, 2.0W  
Frequency: 2402 ~ 2480MHz  
Range:  
Transmit Power: 6.31dBm  
Modulation: GFSK for 1Mbps  
type:  
Channel space: 2MHz  
Antenna Specification: Internal antenna 2.5dBi gain (Max.)  
Temperature Range: -10 °C ~ 50 °C  
Hardware: SWM0507\_BYV3\_boot\_01\_00\_05\_00\_app\_02\_00\_05\_00\_release\_114.b  
Version: yfw  
Software: SWM0507\_BYV3\_boot\_01\_00\_05\_00\_app\_02\_00\_05\_00\_release\_114.b  
Version: yfw  
Sample No: 0001, 0002  
Note: /

## 2.5. TEST OPERATION MODE

Test Item	Mode No.	Description of the modes
Conducted Emission	1	Continuously Transmitting
Radiated Emission	1	Continuously Transmitting (CH0, CH19, CH39)

## 2.6. LOCAL SUPPORTIVE

Name of Equipment	Manufacturer	Model	Serial Number	Note
Notebook	LENOVO	TianYi 310-14ISK	MP18DLC6	/
DC power	Long wei	PS-305DM	180704473	/
<b>Cable</b>				
AC cable	/	/	/	Unshielded, 1.00m
DC cable	/	/	/	Shielded, 1.80m

### Test software:

Software version	Test level
nRFgo Studio	/

### 3. LABORATORY AND ACCREDITATIONS

#### 3.1. LABORATORY

The tests & measurements refer to this report were performed by Shenzhen EMC Laboratory of Guangzhou GRG Metrology & Test Co., Ltd.

Add : Address: No.1301 Guanguang Road Xinlan Community, Guanlan Street,  
Longhua District Shenzhen, 518110, People's Republic of China

P.C. : 518000

Tel : 0755-61180008

Fax : 0755-61180008

#### 3.2. ACCREDITATIONS

A2LA	Certificate Number 2861.01
------	----------------------------

#### 3.3. MEASUREMENT UNCERTAINTY

Where relevant, the following measurement uncertainty levels have been estimated for tests performed on the EUT as specified in CISPR 16-4-2:

Measurement		Frequency	Uncertainty
Radiated Emission	Horizontal	30MHz~1000MHz	4.3dB
		1GHz~18GHz	5.6dB
	Vertical	30MHz~1000MHz	4.3dB
		1GHz~18GHz	5.6dB
Conduction Emission		9 kHz ~ 150 kHz	2.8 dB
		150 kHz ~ 10 MHz	2.8 dB
		10 MHz ~ 30 MHz	2.2 dB

This uncertainty represents an expanded uncertainty factor of  $k=2$ .



**4. LIST OF USED TEST EQUIPMENT AT GRGT**

Name of Equipment	Manufacturer	Model	Serial Number	Calibration Due
<b>Conducted Emissions</b>				
EMI TEST RECEIVER	R&S	ESCI	100783	2020/11/27
LISN(EUT)	R&S	ENV216	101543	2021/03/24
Test S/W	EZ	CCS-3A1-CE	/	/
<b>Radiated Spurious Emission&amp; Restricted bands of operation</b>				
EMI TEST RECEIVER	R&S	ESPI	100529	2020/12/08
Spectrum Analyzer	Agilent	N9010A	MY52221469	2020/11/18
Bilog Antenna	Schwarzbeck	VULB 9163	01279	2021/03/14
Horn Antenna	Schwarzbeck	BBHA 9120D(1201)	02143	2020/12/28
Board-Band Horn Antenna	Schwarzbeck	BBHA 9170	BBHA 9170-497	2020/11/30
Amplifier	Tonscend	TAP9E6343	AP20E806065	2021/06/28
Amplifier	Tonscend	TAP01018048	AP20E8060075	2021/06/28
Amplifier	Tonscend	TAP037030	AP20E8060081	2021/06/28
Test S/W	Tonscend	JS36-RE/2.5.1.5		
<b>6 dB Bandwidth</b>				
Spectrum Analyzer	Agilent	N9010A	MY52221469	2020/11/18
<b>Peak/AV Output Power</b>				
Pulse Power Sentor	Agilent	MA2411B	1126150	2021/04/13
Power Meter	Anritsu	ML2495A	1204003	2021/04/13
<b>Conducted band edges and Spurious Emission</b>				
Spectrum Analyzer	Agilent	N9010A	MY52221469	2020/11/18
<b>Peak Output Spectral Density Measurement</b>				
Spectrum Analyzer	Agilent	N9010A	MY52221469	2020/11/18

## 5. CONDUCTED EMISSION MEASUREMENT

### 5.1. LIMITS

Frequency range	Limits (dB $\mu$ V)	
	Quasi-peak	Average
150kHz ~ 0.5MHz	66~56	56~46
0.5 MHz ~ 5 MHz	56	46
5 MHz ~ 30 MHz	60	50

**NOTE:** (1) The lower limit shall apply at the transition frequencies.

(2) The limit decreases in line with the logarithm of the frequency in the range of 150 kHz to 0.5MHz.

### 5.2. TEST PROCEDURES

#### Procedure of Preliminary Test

Test procedures follow ANSI C63.4:2014.

For measurement of the disturbance voltage the equipment under test (EUT) is connected to the power supply mains and any other extended network via one or more artificial network(s). An EUT, whether intended to be grounded or not, and which is to be used on a table is configured as follows:

- Either the bottom or the rear of the EUT shall be at a controlled distance of 40 cm from a reference ground plane. This ground plane is normally the wall or floor of a shielded room. It may also be a grounded metal plane of at least 2 m by 2 m. This is physically accomplished as follows:

- 1) place the EUT on a table of non-conducting material which is at least 80 cm high. Place the EUT so that it is 40 cm from the wall of the shielded room, or
- 2) place the EUT on a table of non-conducting material which is 40 cm high so that the bottom of the EUT is 40 cm above the ground plane;

- All other conductive surfaces of the EUT shall be at least 80 cm from the reference ground plane;

- The EUT are placed on the floor that one side of the housings is 40 cm from the vertical reference ground plane and other metallic parts;

- Interconnecting cables that hang closer than 40 cm to the ground plane shall be folded back and forth forming a bundle 30 cm to 40 cm long, hanging approximately in the middle between the ground plane and the table.

- I/O cables that are connected to a peripheral shall be bundled in the centre. The end of the cable may be terminated if required using correct terminating impedance. The total length shall not exceed 1 m.

The test mode(s) described in Item 2.4 were scanned during the preliminary test. After the preliminary scan, we found the test mode described in Item 2.4 producing the highest emission level. The EUT configuration and cable configuration of the above highest emission levels were recorded for reference of the final test.

#### Procedure of Final Test

EUT and support equipment were set up on the test bench as per the configuration with highest emission level in the preliminary test. A scan was taken on both power lines, recording at least the six highest emissions. Emission frequency and amplitude were recorded into a computer in which correction factors were used to calculate the emission level and compare reading to the applicable limit. The test data of the worst-case condition(s) was recorded.

### 5.3. TEST SETUP

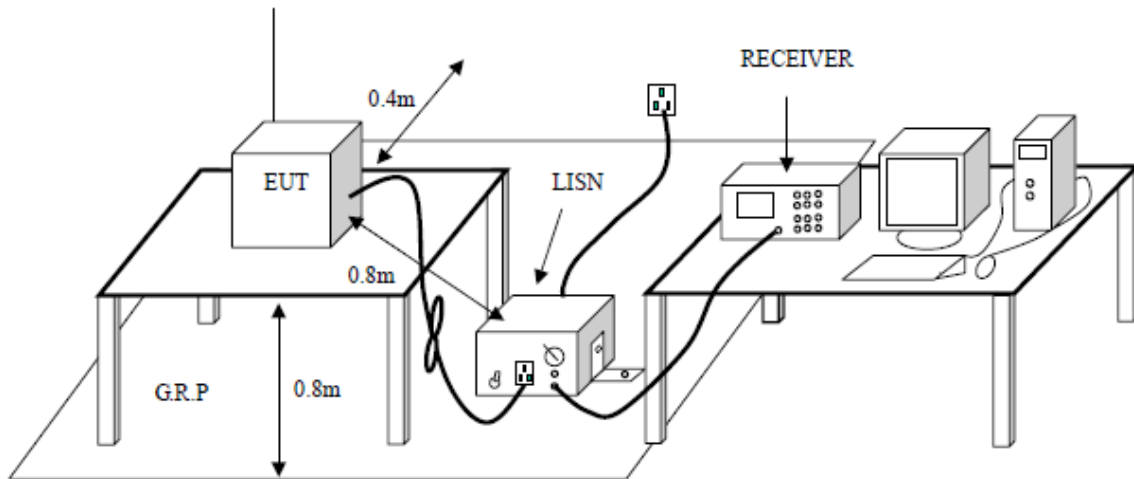

### 5.4. DATA SAMPLE

Frequency (MHz)	QuasiPeak Reading (dBuV)	Average Reading (dBuV)	Correction Factor (dB)	QuasiPeak Result (dBuV)	Average Result (dBuV)	QuasiPeak Limit (dBuV)	Average Limit (dBuV)	QuasiPeak Margin (dB)	Average Margin (dB)	Remark (Pass/Fail)
X.XXXX	32.69	25.65	11.52	44.21	37.17	65.78	55.79	-21.57	-18.62	Pass

Factor = Insertion loss of LISN + Cable Loss  
 Result = Quasi-peak Reading/ Average Reading + Factor  
 Limit =Limit stated in standard  
 Margin = Result (dBuV) – Limit (dBuV)

### 5.5. TEST RESULTS

<b>Model No.</b>	42492	<b>RBW,VBW</b>	9 kHz
<b>Environmental Conditions</b>	25.5°C/44%RH/101.7kPa	<b>Test Mode</b>	Mode 1
<b>Tested By</b>	WuJunLin	<b>Line</b>	L
<b>Tested Date</b>	2020/08/18	<b>Test Voltage</b>	AC120V/60Hz

(The chart below shows the highest readings taken from the final data.)

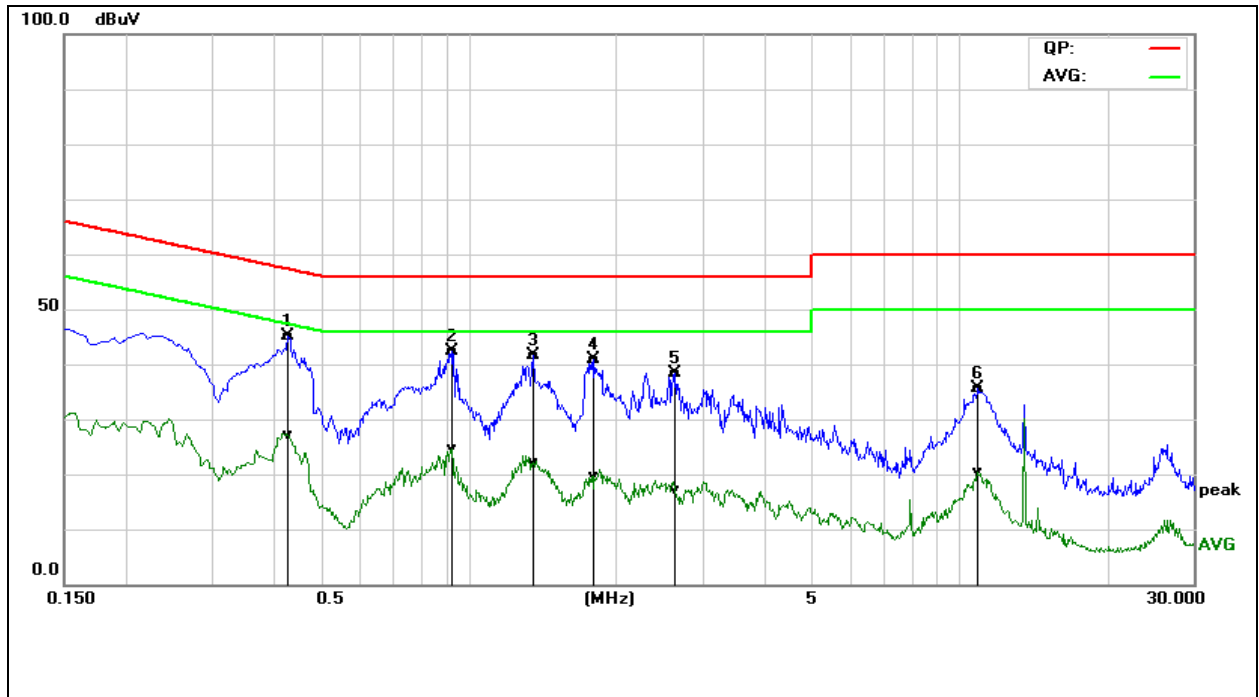

No.	Frequency	QuasiPeak reading	Average reading	Correction factor	QuasiPeak result	Average result	QuasiPeak limit	Average limit	QuasiPeak margin	Average margin	Remark
	(MHz)	(dBuV)	(dBuV)	(dB)	(dBuV)	(dBuV)	(dBuV)	(dBuV)	(dB)	(dB)	
1*	0.4300	35.38	17.38	9.67	45.05	27.05	57.25	47.25	-12.20	-20.20	Pass
2	0.9260	32.74	14.86	9.70	42.44	24.56	56.00	46.00	-13.56	-21.44	Pass
3	1.3580	31.92	12.34	9.71	41.63	22.05	56.00	46.00	-14.37	-23.95	Pass
4	1.8020	31.05	9.91	9.73	40.78	19.64	56.00	46.00	-15.22	-26.36	Pass
5	2.6420	28.56	7.38	9.75	38.31	17.13	56.00	46.00	-17.69	-28.87	Pass
6	10.9340	25.66	10.54	9.85	35.51	20.39	60.00	50.00	-24.49	-29.61	Pass

**REMARKS:** L = Live Line

<b>Model No.</b>	42492	<b>RBW,VBW</b>	9 kHz
<b>Environmental Conditions</b>	25.5°C/44%RH/101.7kPa	<b>Test Mode</b>	Mode 1
<b>Tested By</b>	WuJunLin	<b>Line</b>	N
<b>Tested Date</b>	2020/08/18	<b>Test Voltage</b>	AC120V/60Hz

(The chart below shows the highest readings taken from the final data.)

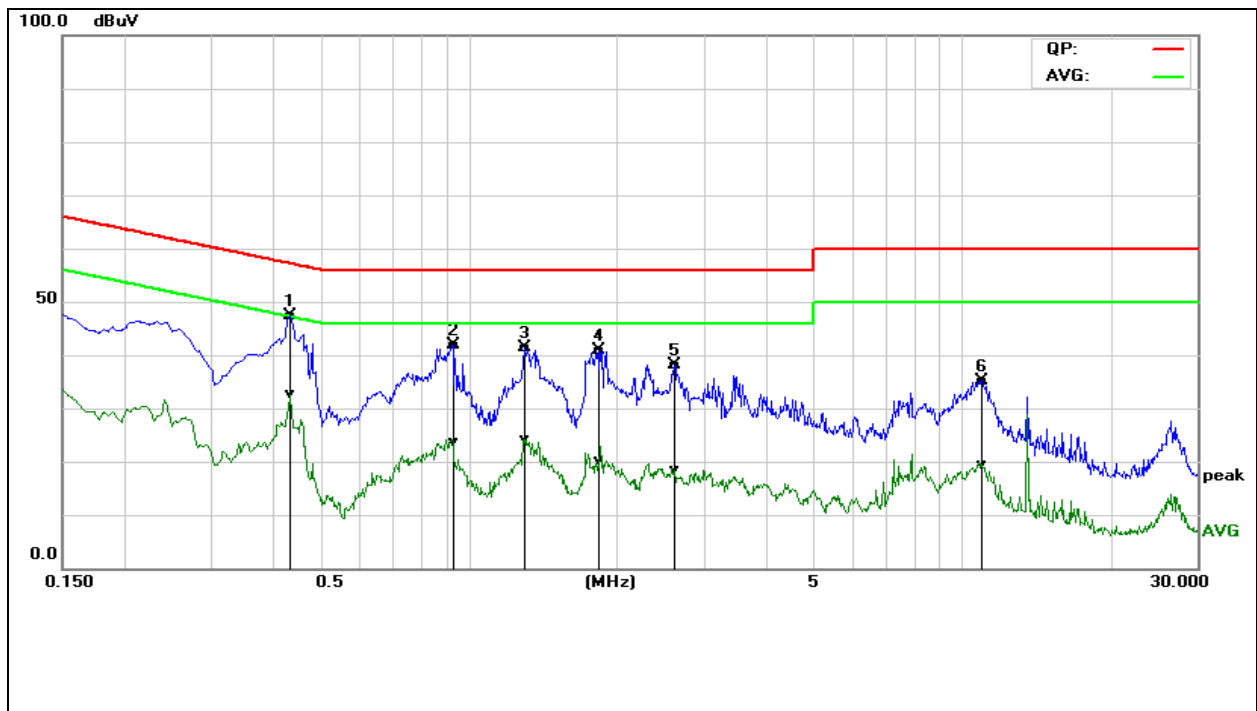

No.	Frequency (MHz)	QuasiPeak reading (dBuV)	Average reading (dBuV)	Correction factor (dB)	QuasiPeak result (dBuV)	Average result (dBuV)	QuasiPeak limit (dBuV)	Average limit (dBuV)	QuasiPeak margin (dB)	Average margin (dB)	Remark
1*	0.4340	37.61	22.94	9.67	47.28	32.61	57.18	47.18	-9.90	-14.57	Pass
2	0.9300	32.21	13.96	9.70	41.91	23.66	56.00	46.00	-14.09	-22.34	Pass
3	1.2980	31.69	14.51	9.71	41.40	24.22	56.00	46.00	-14.60	-21.78	Pass
4	1.8340	31.26	10.33	9.73	40.99	20.06	56.00	46.00	-15.01	-25.94	Pass
5	2.6220	28.48	8.74	9.75	38.23	18.49	56.00	46.00	-17.77	-27.51	Pass
6	11.0100	25.33	9.63	9.85	35.18	19.48	60.00	50.00	-24.82	-30.52	Pass

**REMARKS:** N = Neutral Line.

## 6. RADIATED SPURIOUS EMISSIONS

### 6.1. LIMITS

In any 100 kHz bandwidth outside the frequency band in which the spread spectrum or digitally modulated intentional radiator is operating, the radio frequency power that is produced by the intentional radiator shall be at least 20 dB below that in the 100 kHz bandwidth within the band that contains the highest level of the desired power, based on either an RF conducted or a radiated measurement, provided the transmitter demonstrates compliance with the peak conducted power limits. If the transmitter complies with the conducted power limits based on the use of RMS averaging over a time interval, as permitted under paragraph (b)(3) of this section, the attenuation required under this paragraph shall be 30 dB instead of 20 dB. Attenuation below the general limits specified in §15.209(a) is not required.

Frequency (MHz)	Quasi-peak( $\mu\text{V}/\text{m}$ )	Measurement distance(m)	Quasi-peak( $\text{dB}\mu\text{V}/\text{m}$ )@distance 3m
0.009-0.490	2400/F(kHz)	300	53.8~88.5
0.490-1.705	24000/F(kHz)	30	43~53.8
1.705-30.0	30	30	49.5
30 ~ 88	100	3	40
88~216	150	3	43.5
216 ~ 960	200	3	46
Above 960	500	3	54

NOTE: (1) The lower limit shall apply at the transition frequencies.

### 6.2. TEST PROCEDURES (please refer to measurement standard)

#### 1) Sequence of testing 9 kHz to 30 MHz

##### Setup:

- The equipment was set up to simulate a typical usage like described in the user manual or described by manufacturer.
- If the EUT is a tabletop system, a rotatable table with 0.8 m height is used.
- If the EUT is a floor standing device, it is placed on the ground.
- Auxiliary equipment and cables were positioned to simulate normal operation conditions.
- The AC power port of the EUT (if available) is connected to a power outlet below the turntable.
- The measurement distance is 3 meter.
- The EUT was set into operation.

##### Pre measurement:

- The turntable rotates from 0 ° to 315 ° using 45 ° steps.
- The antenna height is 0.8 meter.
- At each turntable position the analyzer sweeps with peak detection to find the maximum of all emissions

**Final measurement:**

- Identified emissions during the pre measurement the software maximizes by rotating the turntable position (0 ° to 360 °) and by rotating the elevation axes (0 ° to 360 °).
- The final measurement will be done in the position (turntable and elevation) causing the highest emissions with QPK detector.
- The final levels, frequency, measuring time, bandwidth, turntable position, correction factor, margin to the limit and limit will be recorded. Also a plot with the graph of the pre measurement and the limit will be stored.

**2) Sequence of testing 30 MHz to 1 GHz****Setup:**

- The equipment was set up to simulate a typical usage like described in the user manual or described by manufacturer.
- If the EUT is a tabletop system, a table with 0.8 m height is used, which is placed on the ground plane.
- If the EUT is a floor standing device, it is placed on the ground plane with insulation between both.
- Auxiliary equipment and cables were positioned to simulate normal operation conditions
- The AC power port of the EUT (if available) is connected to a power outlet below the turntable.
- The measurement distance is 3 meter.
- The EUT was set into operation.

**Pre measurement:**

- The turntable rotates from 0 ° to 315 ° using 45 ° steps.
- The antenna is polarized vertical and horizontal.
- The antenna height changes from 1 to 3 meter.
- At each turntable position, antenna polarization and height the analyzer sweeps three times in peak to find the maximum of all emissions.

**Final measurement:**

- The final measurement will be performed with minimum the six highest peaks.
- According to the maximum antenna and turntable positions of premeasurement the software maximize the peaks by changing turntable position ( $\pm 45^\circ$ ) and antenna movement between 1 and 4 meter.
- The final measurement will be done with QP detector with an EMI receiver.
- The final levels, frequency, measuring time, bandwidth, antenna height, antenna polarization, turntable angle, correction factor, margin to the limit and limit will be recorded. Also a plot with the graph of the premeasurement with marked maximum final measurements and the limit will be stored.

### **3) Sequence of testing 1 GHz to 18 GHz**

#### **Setup:**

- The equipment was set up to simulate a typical usage like described in the user manual or described by manufacturer.
- If the EUT is a tabletop system, a rotatable table with 1.5 m height is used.
- If the EUT is a floor standing device, it is placed on the ground plane with insulation between both.
- Auxiliary equipment and cables were positioned to simulate normal operation conditions
- The AC power port of the EUT (if available) is connected to a power outlet below the turntable.
- The measurement distance is 3 meter.
- The EUT was set into operation.

#### **Pre measurement:**

- The turntable rotates from 0 ° to 315 ° using 45 ° steps.
- The antenna is polarized vertical and horizontal.
- The antenna height scan range is 1 meter to 2.5 meter.
- At each turntable position and antenna polarization the analyzer sweeps with peak detection to find the maximum of all emissions.



**Final measurement:**

- The final measurement will be performed with minimum the six highest peaks.
- According to the maximum antenna and turntable positions of premeasurement the software maximize the peaks by changing turntable position ( $\pm 45^\circ$ ) and antenna movement between 1 and 4 meter. This procedure is repeated for both antenna polarizations.
- The final measurement will be done in the position (turntable, EUT-table and antenna polarization) causing the highest emissions with Peak and Average detector.
- The final levels, frequency, measuring time, bandwidth, turntable position, EUT-table position, antenna polarization, correction factor, margin to the limit and limit will be recorded. Also a plot with the graph of the pre measurement with marked maximum final measurements and the limit will be stored.

**4) Sequence of testing above 18 GHz****Setup:**

- The equipment was set up to simulate a typical usage like described in the user manual or described by manufacturer.
- If the EUT is a tabletop system, a rotatable table with 1.5 m height is used.
- If the EUT is a floor standing device, it is placed on the ground plane with insulation between both.
- Auxiliary equipment and cables were positioned to simulate normal operation conditions
- The AC power port of the EUT (if available) is connected to a power outlet below the turntable.
- The measurement distance is 1 meter.
- The EUT was set into operation.

**Pre measurement:**

- The antenna is moved spherical over the EUT in different polarisations of the antenna.

**Final measurement:**

- The final measurement will be performed at the position and antenna orientation for all detected emissions that were found during the premeasurements with Peak and Average detector.
- The final levels, frequency, measuring time, bandwidth, correction factor, margin to the limit and limit will be recorded. Also a plot with the graph of the premeasurement and the limit will be stored.

NOTE: The resolution bandwidth of test receiver/spectrum analyzer is 1MHz and the video bandwidth is 3MHz for RMS Average (Duty cycle < 98%) for Average detection (AV) at frequency above 1GHz, then the measurement results was added to a correction factor ( $10 \log(1/\text{duty cycle})$ ).

### 6.3. TEST SETUP

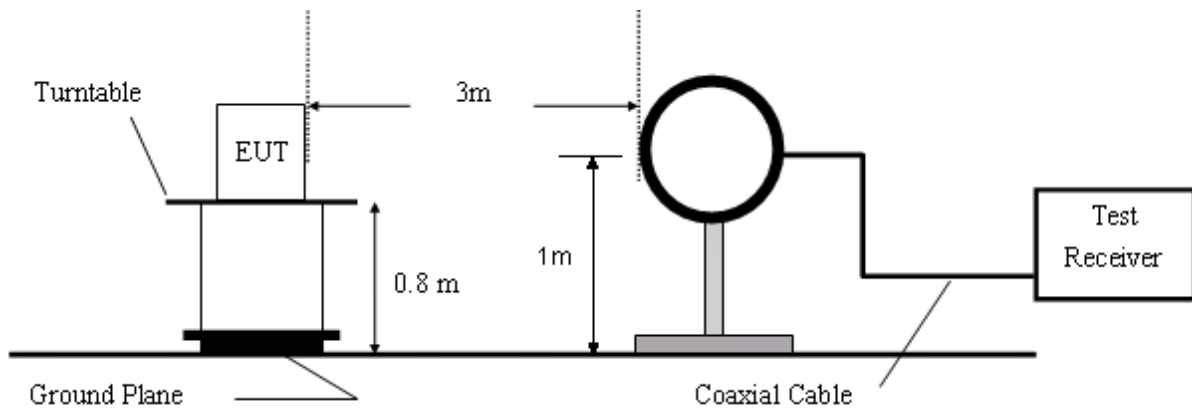

Figure 1. 9KHz to 30MHz radiated emissions test configuration

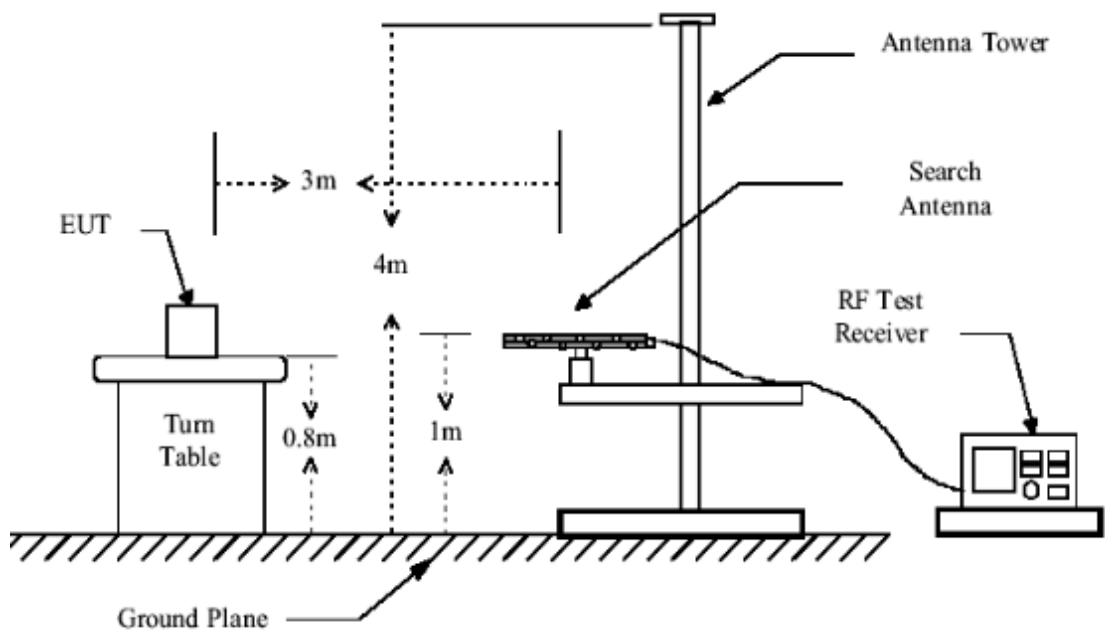

Figure 2. 30MHz to 1GHz radiated emissions test configuration

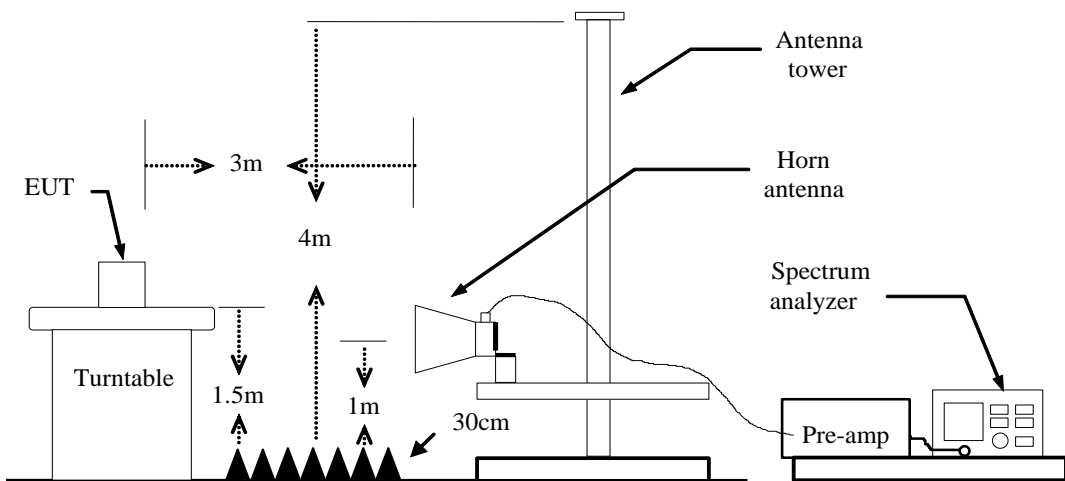

Figure 3. Above 1GHz radiated emissions test configuration

## 6.4. DATA SAMPLE

### 30MHz to 1GHz

No.	Frequency	Reading	Correct	Result	Limit	Margin	Remark	Pole
	(MHz)	(dBuV/m)	Factor(dB/m)	(dBuV/m)	(dBuV/m)	(dB)		
xxx	xxx	37.06	-15.48	21.58	40.00	-18.42	QP	Vertical

### Above 1 GHz

No.	Frequency	Reading	Correct	Result	Limit	Margin	Remark	Pole
	(MHz)	(dBuV/m)	Factor(dB/m)	(dBuV/m)	(dBuV/m)	(dB)		
xxx	xxx	65.45	-11.12	54.33	74.00	-19.67	Peak	Vertical
xxx	xxx	63.00	-11.12	51.88	54.00	-2.12	AVG	Vertical

Frequency (MHz)	= Emission frequency in MHz
Ant.Pol. (H/V)	= Antenna polarization
Reading (dBuV)	= Uncorrected Analyzer / Receiver reading
Correction Factor (dB/m)	= Antenna factor + Cable loss – Amplifier gain
Result (dBuV/m)	= Reading (dBuV) + Correction Factor (dB/m)
Limit (dBuV/m)	= Limit stated in standard
Margin (dB)	= Remark Result (dBuV/m) – Limit (dBuV/m)
Peak	= Peak Reading
QP	= Quasi-peak Reading
AVG	= Average Reading

### 6.5. TEST RESULTS

**30MHz to 1GHz**

Mode: TX

Lowest channel (2402MHz)

Date: 2020/08/28

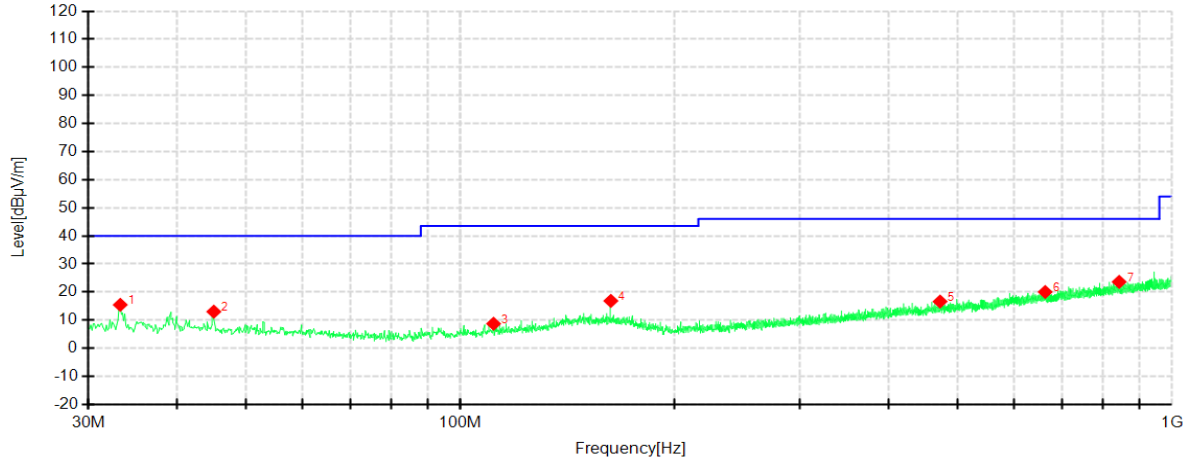

Suspected Data List										
NO.	Freq. [MHz]	Reading [dBµV/m]	Level [dBµV/m]	Factor [dB]	Limit [dBµV/m]	Margin [dB]	Trace	Height [cm]	Angle [°]	Polarity
1	33.273	45.73	15.46	-30.27	40.00	24.54	PK	100	319	Vertical
2	45.035	43.01	13.03	-29.98	40.00	26.97	PK	100	33	Vertical
3	111.35	39.26	8.73	-30.53	43.50	34.77	PK	100	44	Vertical
4	162.76	44.16	16.86	-27.30	43.50	26.64	PK	100	300	Vertical
5	472.19	39.03	16.63	-22.40	46.00	29.37	PK	100	296	Vertical
6	663.53	38.54	20.05	-18.49	46.00	25.95	PK	100	277	Vertical
7	842.98	39.11	23.63	-15.48	46.00	22.37	PK	100	138	Vertical

Mode: TX

Lowest channel (2402MHz)

Date: 2020/08/28

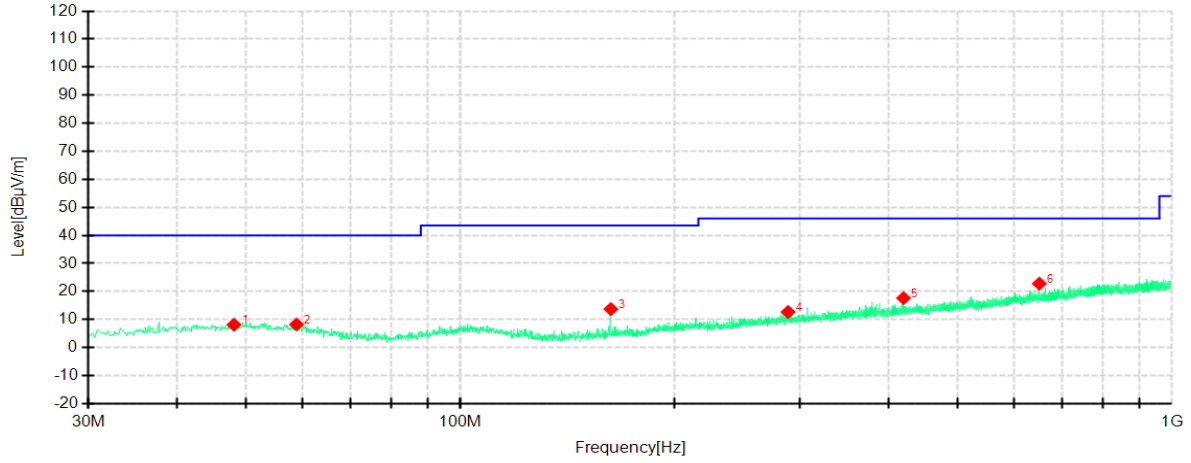

Suspected Data List										
NO.	Freq. [MHz]	Reading [dBμV/m]	Level [dBμV/m]	Factor [dB]	Limit [dBμV/m]	Margin [dB]	Trace	Height [cm]	Angle [°]	Polarity
1	48.066	37.09	8.13	-28.96	40.00	31.87	PK	100	128	Horizontal
2	58.857	37.85	8.23	-29.62	40.00	31.77	PK	100	68	Horizontal
3	162.76	45.82	13.71	-32.11	43.50	29.79	PK	100	94	Horizontal
4	288.74	39.40	12.69	-26.71	46.00	33.31	PK	100	296	Horizontal
5	419.57	40.85	17.63	-23.22	46.00	28.37	PK	100	346	Horizontal
6	651.04	41.56	22.78	-18.78	46.00	23.22	PK	100	242	Horizontal

**Remark:**

- 1 No emission found between lowest internal used/generated frequency to 30MHz.
- 2 Data of measurement within this frequency range in the table above the reading of PK detector are more 6dB than QP limit, therefore it's unnecessary to performed QP scan.
- 3 The IF bandwidth of Receiver between 30MHz to 1GHz was 120 kHz.

Mode: TX  
 Middle channel (2440MHz)

Date: 2020/08/28

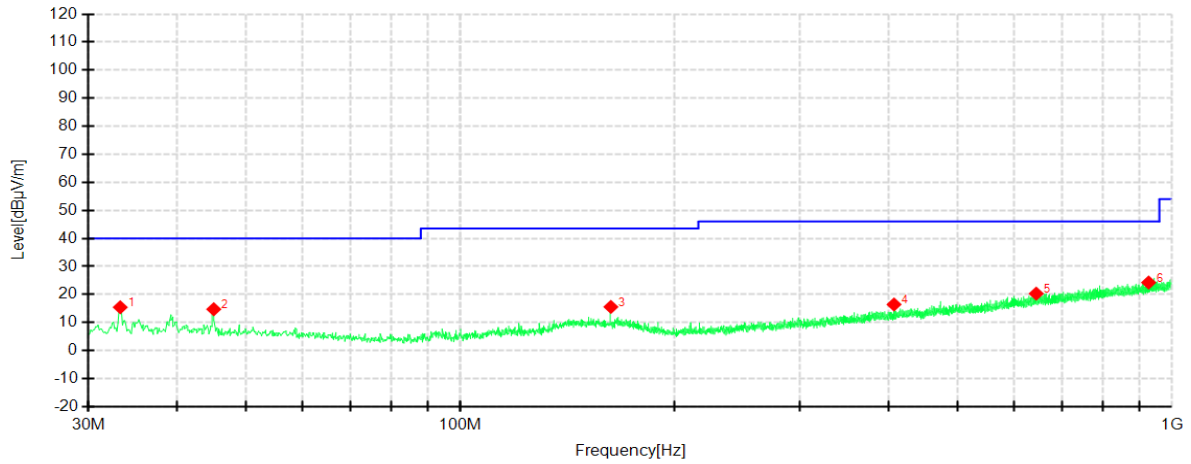

Suspected Data List										
NO.	Freq. [MHz]	Reading [dBµV/m]	Level [dBµV/m]	Factor [dB]	Limit [dBµV/m]	Margin [dB]	Trace	Height [cm]	Angle [°]	Polarity
1	33.273	45.71	15.44	-30.27	40.00	24.56	PK	100	151	Vertical
2	45.035	44.72	14.74	-29.98	40.00	25.26	PK	100	292	Vertical
3	162.76	42.88	15.58	-27.30	43.50	27.92	PK	100	284	Vertical
4	406.84	40.49	16.43	-24.06	46.00	29.57	PK	100	37	Vertical
5	644.61	39.09	20.31	-18.78	46.00	25.69	PK	100	360	Vertical
6	927.37	38.67	24.26	-14.41	46.00	21.74	PK	100	292	Vertical

**Remark:**

- 1 No emission found between lowest internal used/generated frequency to 30MHz.
- 2 Data of measurement within this frequency range in the table above the reading of PK detector are more 6dB than QP limit, therefore it's unnecessary to performed QP scan.
- 3 The IF bandwidth of Receiver between 30MHz to 1GHz was 120 kHz.

Mode: TX  
 Middle channel (2440MHz)

Date: 2020/08/28

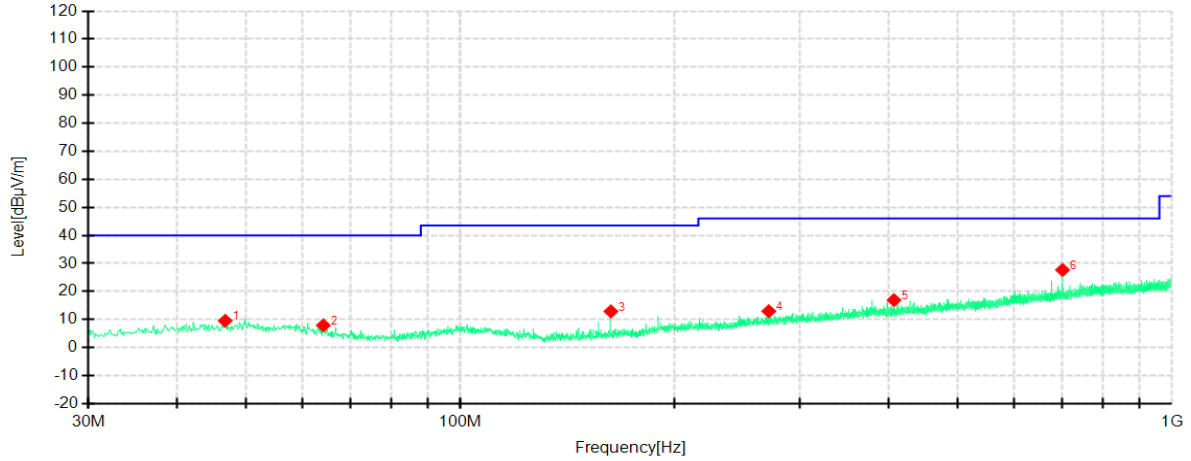

Suspected Data List										
NO.	Freq. [MHz]	Reading [dBµV/m]	Level [dBµV/m]	Factor [dB]	Limit [dBµV/m]	Margin [dB]	Trace	Height [cm]	Angle [°]	Polarity
1	46.732	38.68	9.56	-29.12	40.00	30.44	PK	100	104	Horizontal
2	64.192	38.80	7.91	-30.89	40.00	32.09	PK	100	195	Horizontal
3	162.76	45.01	12.90	-32.11	43.50	30.60	PK	100	84	Horizontal
4	271.28	40.16	12.97	-27.19	46.00	33.03	PK	100	73	Horizontal
5	406.84	40.89	16.94	-23.95	46.00	29.06	PK	100	46	Horizontal
6	701.84	45.98	27.68	-18.30	46.00	18.32	PK	100	272	Horizontal

**Remark:**

- 1 No emission found between lowest internal used/generated frequency to 30MHz.
- 2 Data of measurement within this frequency range in the table above the reading of PK detector are more 6dB than QP limit, therefore it's unnecessary to performed QP scan.
- 3 The IF bandwidth of Receiver between 30MHz to 1GHz was 120 kHz.

Mode: TX  
 Highest channel (2480MHz)

Date: 2020/08/28

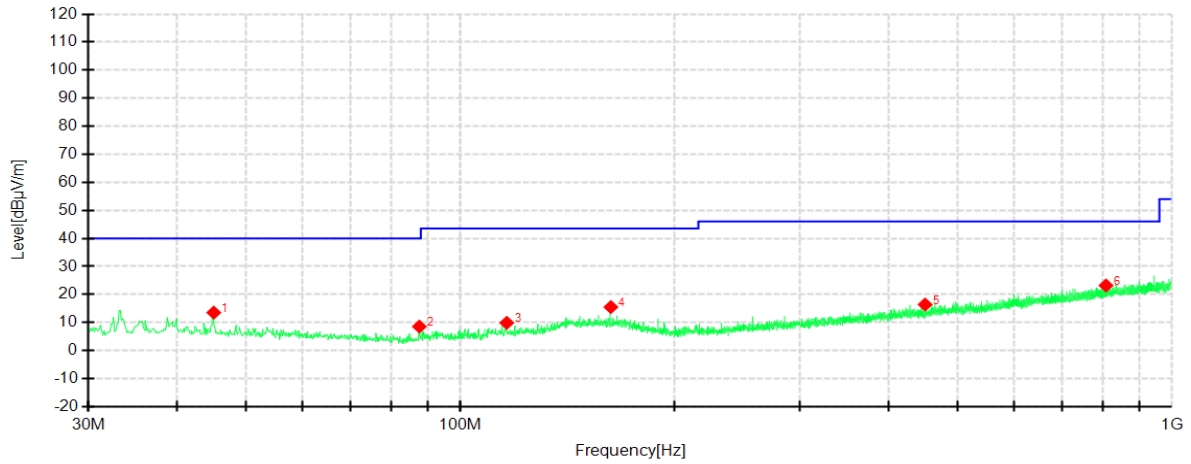

Suspected Data List										
NO.	Freq. [MHz]	Reading [dBµV/m]	Level [dBµV/m]	Factor [dB]	Limit [dBµV/m]	Margin [dB]	Trace	Height [cm]	Angle [°]	Polarity
1	45.035	43.51	13.53	-29.98	40.00	26.47	PK	100	334	Vertical
2	87.593	41.00	8.56	-32.44	40.00	31.44	PK	100	214	Vertical
3	116.20	40.06	9.90	-30.16	43.50	33.60	PK	100	26	Vertical
4	162.76	42.80	15.50	-27.30	43.50	28.00	PK	100	288	Vertical
5	449.88	39.81	16.41	-23.40	46.00	29.59	PK	100	256	Vertical
6	807.69	39.37	23.20	-16.17	46.00	22.80	PK	100	307	Vertical

**Remark:**

- 1 No emission found between lowest internal used/generated frequency to 30MHz.
- 2 Data of measurement within this frequency range in the table above the reading of PK detector are more 6dB than QP limit, therefore it's unnecessary to performed QP scan.
- 3 The IF bandwidth of Receiver between 30MHz to 1GHz was 120 kHz.



Mode: TX  
 Highest channel (2480MHz)

Date: 2020/08/28

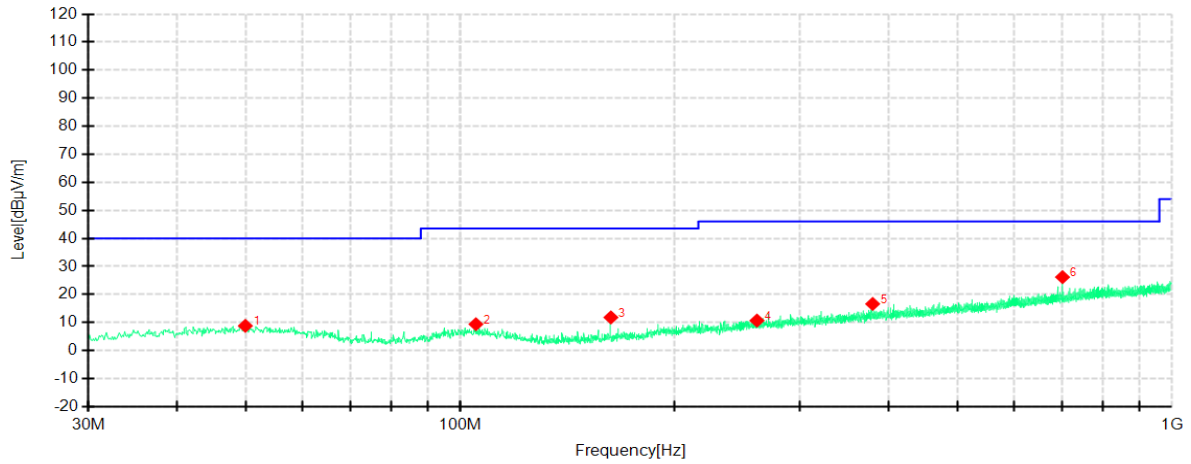

Suspected Data List										
NO.	Freq. [MHz]	Reading [dBµV/m]	Level [dBµV/m]	Factor [dB]	Limit [dBµV/m]	Margin [dB]	Trace	Height [cm]	Angle [°]	Polarity
1	49.885	37.55	8.81	-28.74	40.00	31.19	PK	100	237	Horizontal
2	105.17	39.48	9.39	-30.09	43.50	34.11	PK	100	295	Horizontal
3	162.76	43.93	11.82	-32.11	43.50	31.68	PK	100	103	Horizontal
4	261.10	38.16	10.69	-27.47	46.00	35.31	PK	100	103	Horizontal
5	379.68	41.03	16.64	-24.39	46.00	29.36	PK	100	57	Horizontal
6	701.84	44.49	26.19	-18.30	46.00	19.81	PK	100	330	Horizontal

**Remark:**

- 1 No emission found between lowest internal used/generated frequency to 30MHz.
- 2 Data of measurement within this frequency range in the table above the reading of PK detector are more 6dB than QP limit, therefore it's unnecessary to performed QP scan.
- 3 The IF bandwidth of Receiver between 30MHz to 1GHz was 120 kHz.

**Above 1GHz**

According to C63.10, if the peak (or quasi-peak) measured value complies with the average limit, it is unnecessary to perform an average measurement, so AV emission value did not show in below table if the peak value complies with average limit.

Mode: TX

Lowest channel (2402MHz)

Date: 2020/08/27

Suspected Data List									
NO	Freq. [MHz]	PK Reading [dB $\mu$ V/m]	PK Level [dB $\mu$ V/m]	Factor [dB]	PK Limit [dB $\mu$ V/m]	Margin [dB]	Height [cm]	Angle [°]	Polarity
1	1746.7911	52.88	44.59	-8.29	74.00	29.41	150	338	Vertical
2	4805.4861	62.36	51.77	-10.59	74.00	22.23	150	153	Vertical
3	5760.1972	56.00	47.09	-8.91	74.00	26.91	150	232	Vertical
4	6016.2869	55.64	47.57	-8.07	74.00	26.43	150	202	Vertical
5	8572.8981	47.71	47.28	-0.43	74.00	26.72	150	348	Vertical
6	11444.531	44.27	50.70	6.43	74.00	23.30	150	251	Vertical

AV Final Data List									
NO	Freq. [MHz]	Factor [dB]	AV Reading [dB $\mu$ V/m]	AV Value [dB $\mu$ V/m]	AV Limit [dB $\mu$ V/m]	AV Margin [dB]	Height [cm]	Angle [°]	Polarity
1	4803.7561	-10.61	39.77	29.16	54.00	24.84	131	11.9	Vertical

Mode: TX

Lowest channel (2402 MHz)

Date: 2020/08/27

Suspected Data List									
NO	Freq. [MHz]	PK Reading [dB $\mu$ V/m]	PK Level [dB $\mu$ V/m]	Factor [dB]	PK Limit [dB $\mu$ V/m]	Margin [dB]	Height [cm]	Angle [°]	Polarity
1	2441.5736	49.70	44.63	-5.07	74.00	29.37	150	184	Horizon
2	4803.3431	55.39	44.77	-10.62	74.00	29.23	150	181	Horizon
3	5761.2687	53.97	45.06	-8.91	74.00	28.94	150	240	Horizon
4	8582.5416	47.12	46.73	-0.39	74.00	27.27	150	250	Horizon
5	11362.025	44.56	51.23	6.67	74.00	22.77	150	53	Horizon
6	14604.400	42.88	53.45	10.57	74.00	20.55	150	133	Horizon

Mode: TX  
Middle channel (2440MHz)

Date: 2020/08/27

Suspected Data List									
NO	Freq. [MHz]	PK Reading [dB $\mu$ V/m]	PK Level [dB $\mu$ V/m]	Factor [dB]	PK Limit [dB $\mu$ V/m]	Margin [dB]	Height [cm]	Angle [°]	Polarity
1	1764.1274	53.44	45.13	-8.31	74.00	28.87	150	292	Vertical
2	2462.5771	49.28	44.19	-5.09	74.00	29.81	150	208	Vertical
3	4879.4200	60.97	51.62	-9.35	74.00	22.38	150	182	Vertical
4	5760.1972	56.22	47.31	-8.91	74.00	26.69	150	153	Vertical
5	6016.2869	55.49	47.42	-8.07	74.00	26.58	150	241	Vertical
6	7319.2371	52.53	48.98	-3.55	74.00	25.02	150	211	Vertical

AV Final Data List									
NO	Freq. [MHz]	Factor [dB]	AV Reading [dB $\mu$ V/m]	AV Value [dB $\mu$ V/m]	AV Limit [dB $\mu$ V/m]	AV Margin [dB]	Height [cm]	Angle [°]	Polarity
1	4879.2736	-9.35	37.94	28.59	54.00	25.41	172	34.8	Vertical

Mode: TX  
Middle channel (2440MHz)

Date: 2020/08/27

Suspected Data List									
NO	Freq. [MHz]	PK Reading [dB $\mu$ V/m]	PK Level [dB $\mu$ V/m]	Factor [dB]	PK Limit [dB $\mu$ V/m]	Margin [dB]	Height [cm]	Angle [°]	Polarity
1	1746.7911	49.21	40.92	-8.29	74.00	33.08	150	141	Horizontal
2	4879.4200	55.33	45.98	-9.35	74.00	28.02	150	188	Horizontal
3	5760.1972	53.92	45.01	-8.91	74.00	28.99	150	228	Horizontal
4	6016.2869	51.18	43.11	-8.07	74.00	30.89	150	207	Horizontal
5	8753.9824	47.80	47.25	-0.55	74.00	26.75	150	277	Horizontal
6	14621.544	42.99	53.43	10.44	74.00	20.57	150	317	Horizontal

Mode: TX  
Highest channel (2480MHz)

Date: 2020/08/27

Suspected Data List									
NO	Freq. [MHz]	PK Reading [dB $\mu$ V/m]	PK Level [dB $\mu$ V/m]	Factor [dB]	PK Limit [dB $\mu$ V/m]	Margin [dB]	Height [cm]	Angle [°]	Polarity
1	1908.4847	47.70	40.25	-7.45	74.00	33.75	150	300	Vertical
2	4960.8543	61.67	52.87	-8.80	74.00	21.13	150	143	Vertical
3	5760.1972	56.01	47.10	-8.91	74.00	26.90	150	152	Vertical
4	6016.2869	55.57	47.50	-8.07	74.00	26.50	150	240	Vertical
5	7439.2457	49.52	47.01	-2.51	74.00	26.99	150	191	Vertical
6	14545.467	43.37	53.70	10.33	74.00	20.30	150	34	Vertical

AV Final Data List									
NO	Freq. [MHz]	Factor [dB]	AV Reading [dB $\mu$ V/m]	AV Value [dB $\mu$ V/m]	AV Limit [dB $\mu$ V/m]	AV Margin [dB]	Height [cm]	Angle [°]	Polarity
1	4959.6538	-8.80	41.58	32.78	54.00	21.22	101	154.4	Vertical

Mode: TX  
Highest channel (2480MHz)

Date: 2020/08/27

Suspected Data List									
NO	Freq. [MHz]	PK Reading [dB $\mu$ V/m]	PK Level [dB $\mu$ V/m]	Factor [dB]	PK Limit [dB $\mu$ V/m]	Margin [dB]	Height [cm]	Angle [°]	Polarity
1	1763.7940	51.93	43.62	-8.31	74.00	30.38	150	280	Horizontal
2	4959.7828	56.12	47.32	-8.80	74.00	26.68	150	192	Horizontal
3	5760.1972	54.41	45.50	-8.91	74.00	28.50	150	232	Horizontal
4	6016.2869	52.01	43.94	-8.07	74.00	30.06	150	202	Horizontal
5	7440.3172	48.85	46.33	-2.52	74.00	27.67	150	104	Horizontal
6	14004.357	43.61	53.98	10.37	74.00	20.02	150	357	Horizontal

AV Final Data List									
NO	Freq. [MHz]	Factor [dB]	AV Reading [dB $\mu$ V/m]	AV Value [dB $\mu$ V/m]	AV Limit [dB $\mu$ V/m]	AV Margin [dB]	Height [cm]	Angle [°]	Polarity
1	14004.357	10.37	32.54	42.91	54.00	11.09	150	357	Horizontal

## 7. 6dB BANDWIDTH

### 7.1. LIMITS

Systems using digital modulation techniques may operate in the 902–928 MHz, 2400–2483.5 MHz, and 5725–5850 MHz bands. The minimum 6 dB bandwidth shall be at least 500 kHz.

### 7.2. TEST PROCEDURES

- 1) Remove the antenna from the EUT, and then connect a low loss RF cable from antenna port to the spectrum analyzer.
- 2) Set resolution bandwidth (RBW) = 100kHz. Set the video bandwidth (VBW)  $\geq 3 \times$  RBW. Detector = Peak. Trace mode = max hold. Sweep = auto couple. Allow the trace to stabilize, record 6dB bandwidth value.
- 3) Repeat above procedures until all frequencies measured were complete.

### 7.3. TEST SETUP

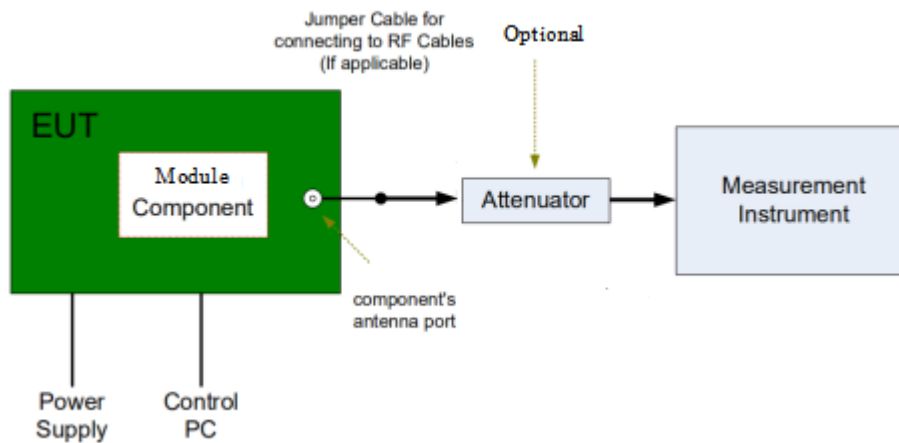

### 7.4. TEST RESULTS

Channel	Frequency (MHz)	Bandwidth (kHz)	Limit (kHz)	Test Result
Lowest	2402	701.9	>500	PASS
Middle	2440	691.1		PASS
Highest	2480	787.1		PASS

Lowest channel (2402MHz)

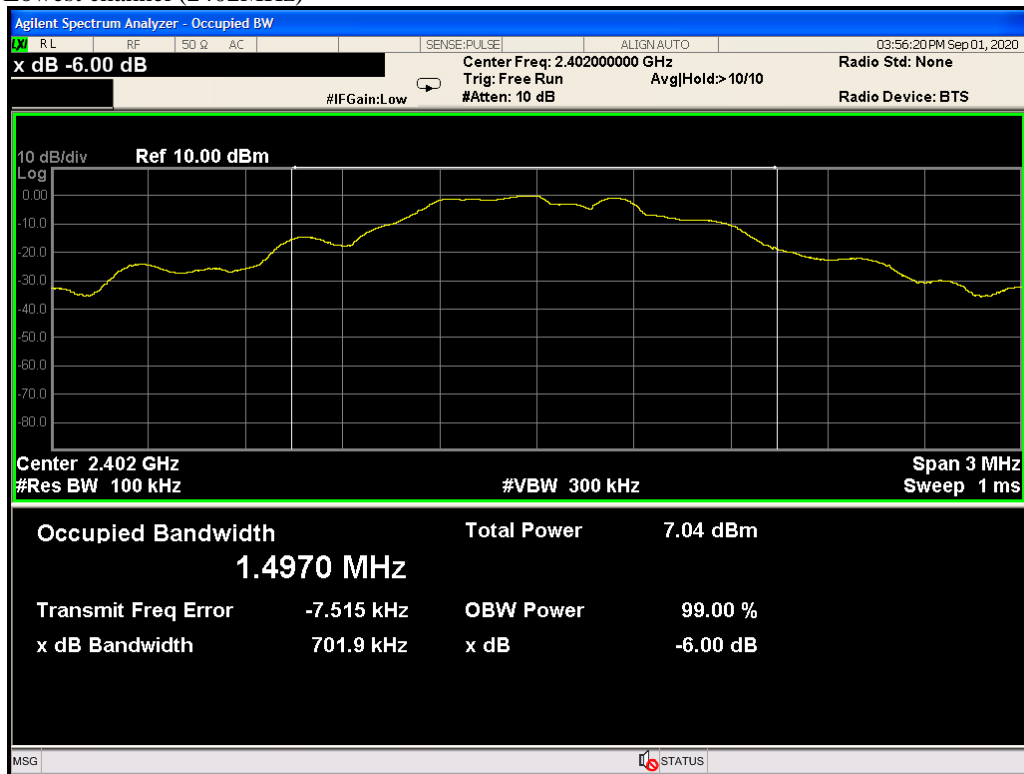

Middle channel (2440 MHz)

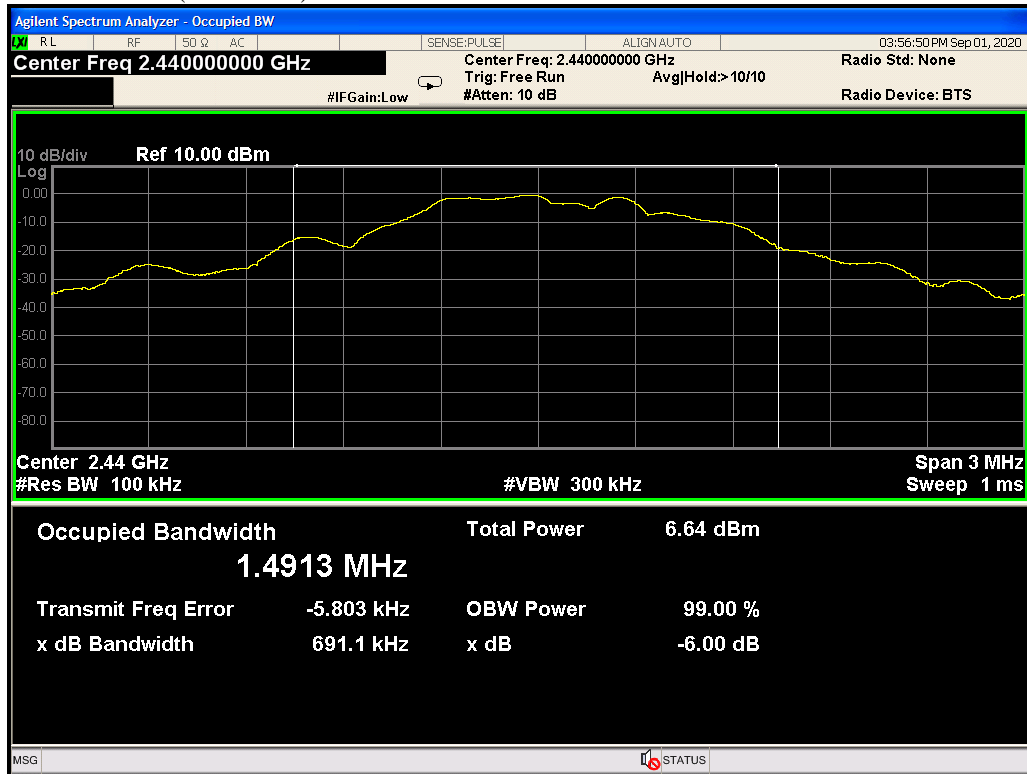

Highest channel (2480MHz)

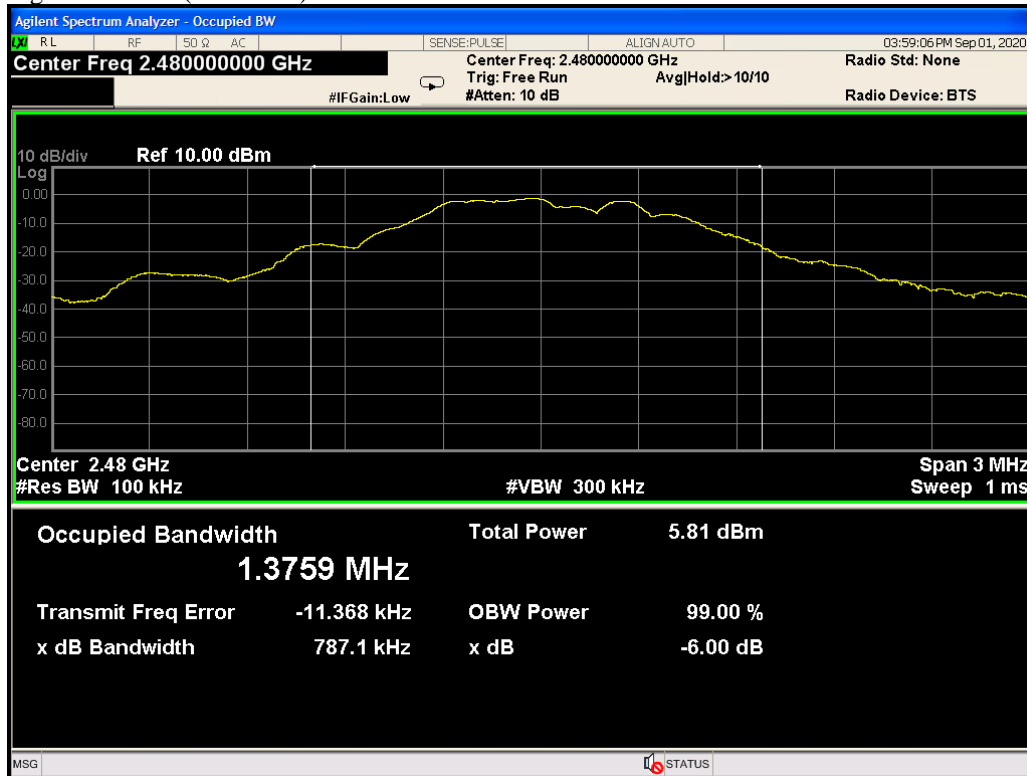

## 8. MAXIMUM PEAK OUTPUT POWER

### 8.1.LIMITS

The maximum Peak output power measurement is 1W

### 8.2.TEST PROCEDURES

- 1) Place the EUT on a bench and set it in transmitting mode.
- 2) Remove the antenna from the EUT and then connect a low loss RF cable from the antenna port to the power meter.

### 8.3.TEST SETUP

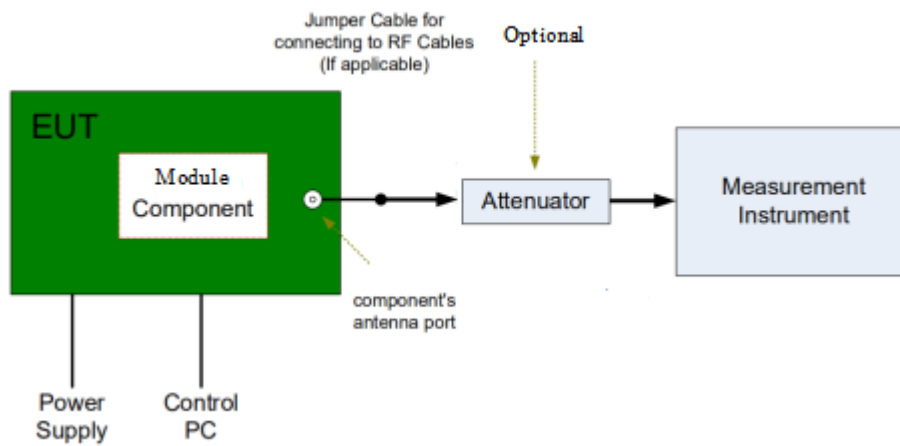

### 8.4.TEST RESULTS

Channel	Frequency (MHz)	Measured Channel Power (dBm)	Limit	Peak/ Average	Result
Lowest	2402	6.31	1W (30dBm)	Peak	Pass
Middle	2440	6.12			Pass
Highest	2480	5.84			Pass
Lowest	2402	-1.70		Average	Pass
Middle	2440	-2.13			Pass
Highest	2480	-2.90			Pass



## 9. POWER SPECTRAL DENSITY

### 9.1. LIMITS

For digitally modulated systems, the power spectral density conducted from the intentional radiator to the antenna shall not be greater than 8 dBm in any 3 kHz band during any time interval of continuous transmission. This power spectral density shall be determined in accordance with the provisions of paragraph (b) of this section. The same method of determining the conducted output power shall be used to determine the power spectral density.

### 9.2. TEST PROCEDURES

- 1) Remove the antenna from the EUT, and then connect a low loss RF cable from antenna port to the spectrum analyzer.
- 2) Position the EUT was set without connection to measurement instrument. Turn on the EUT and connect its antenna terminal to measurement instrument via a low loss cable. Then set it to any one measured frequency within its operating range, and make sure the instrument is operated in its linear range.
- 3) Set the analyzer span to 1.5 times the DTS bandwidth. Set the RBW = 3 kHz. Set the VBW  $\geq 3$  RBW. Detector = peak. Ensure that the number of measurement points in the sweep  $\geq 2 \times$  span/RBW (use of a greater number of measurement points than this minimum requirement is recommended).
- 4) Repeat above procedures until all frequencies measured were complete.

### 9.3. TEST SETUP

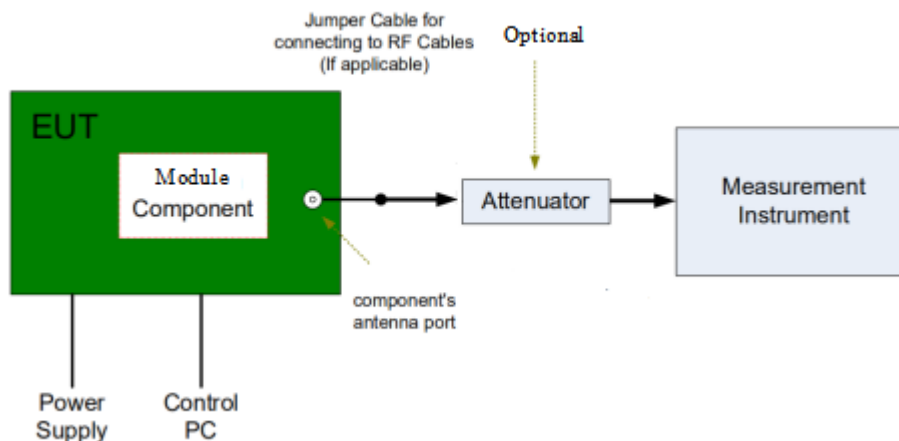

### 9.4. TEST RESULTS

Channel	Frequency (MHz)	PPSD (dBm)	Limit (dBm/3kHz)	Test Result
Lowest	2402	-14.359	8	PASS
Middle	2440	-15.301		PASS
Highest	2480	-14.910		PASS

Lowest channel (2402MHz)



Middle channel (2440 MHz)



Highest channel (2480MHz)



## 10. CONDUCTED BAND EDGES AND SPURIOUS EMISSIONS

### 10.1. LIMITS

(d) In any 100 kHz bandwidth outside the frequency band in which the spread spectrum or digitally modulated intentional radiator is operating, the radio frequency power that is produced by the intentional radiator shall be at least 20 dB below that in the 100 kHz bandwidth within the band that contains the highest level of the desired power, based on either an RF conducted or a radiated measurement, provided the transmitter demonstrates compliance with the peak conducted power limits. If the transmitter complies with the conducted power limits based on the use of RMS averaging over a time interval, as permitted under paragraph (b)(3) of this section, the attenuation required under this paragraph shall be 30 dB instead of 20 dB.

### 10.2. TEST PROCEDURES

Test procedures follow KDB 558074 D01 DTS Measurement Guidance v05r02.

Remove the antenna from the EUT and then connect a low attenuation cable from the antenna port to the spectrum.

- 1) Remove the antenna from the EUT and then connect a low attenuation cable from the antenna port to the spectrum.
- 2) Set the spectrum analyzer: RBW =100KHz; VBW =300KHz, Span = 10MHz to 26GHz; Sweep = auto; Detector Function = Peak. Trace = Max, hold.
- 3) Measure and record the results in the test report.
- 4) The RF fundamental frequency should be excluded against the limit line in the operating frequency band.
- 5) Measurements are made over the 9 kHz to 26GHz range with the transmitter set to the lowest, middle, and highest channels. No emission found between lowest internal used/generated frequency to 10MHz, it is only recorded 10MHz to 26GHz.

### 10.3. TEST SETUP

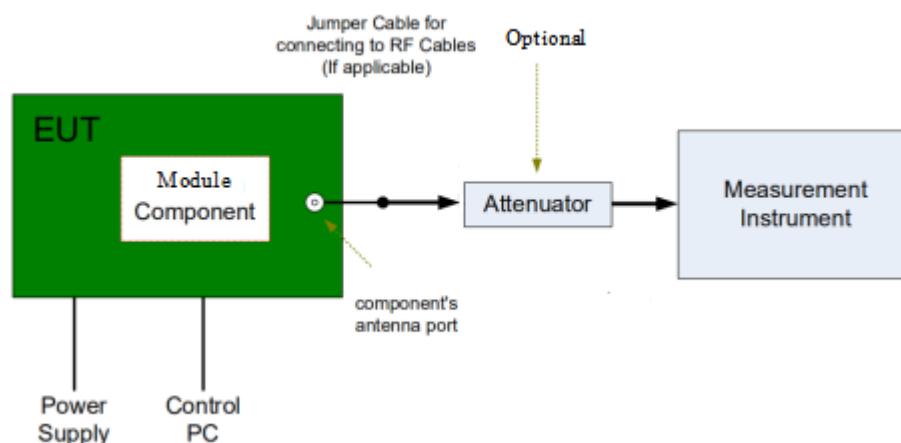

### 10.4. TEST RESULTS

Lowest channel (2402MHz)  
30MHz-26.5GHz

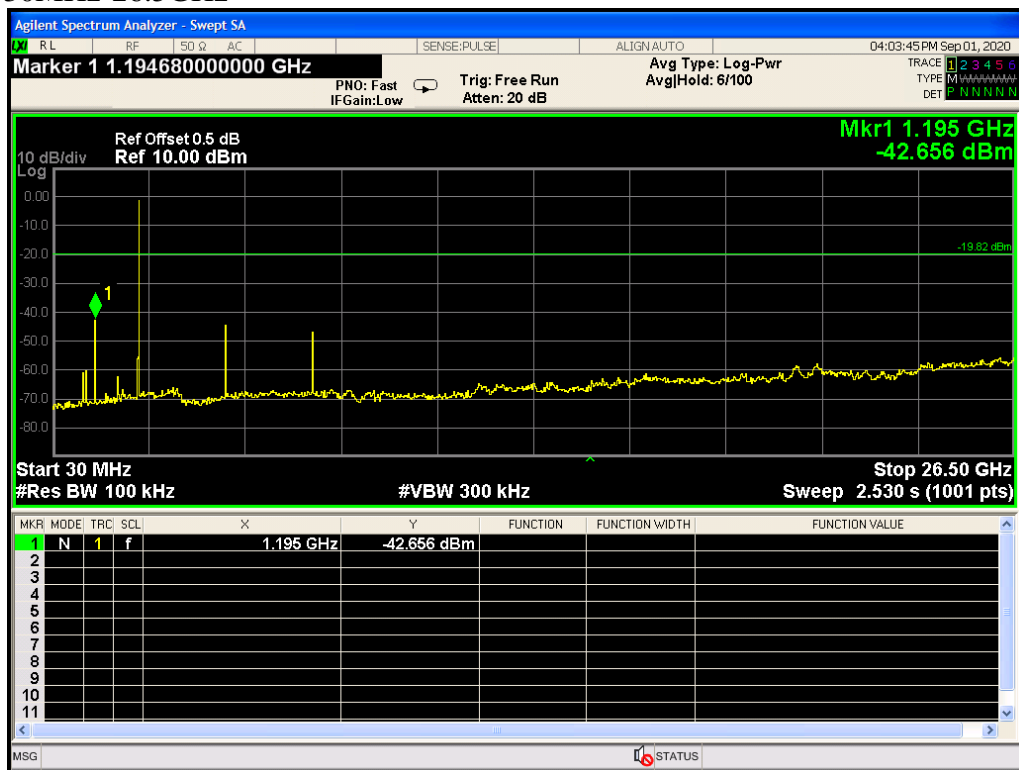

2.31GHz-2.41GHz

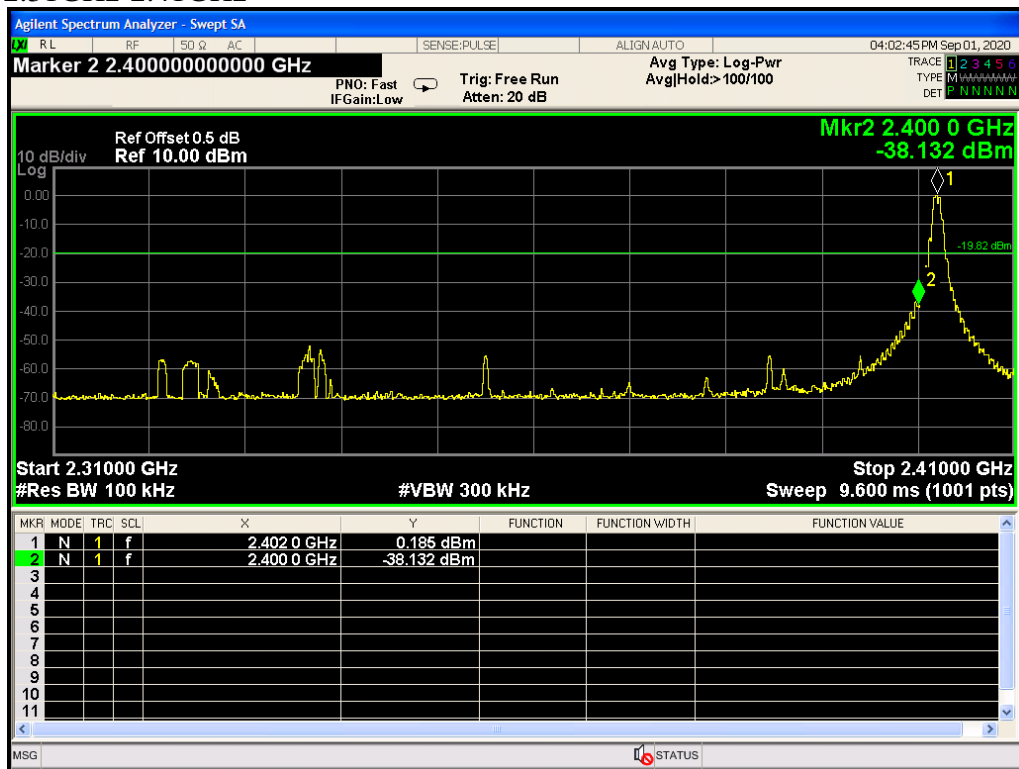

Middle channel (2440 MHz)  
30MHz-26.5GHz

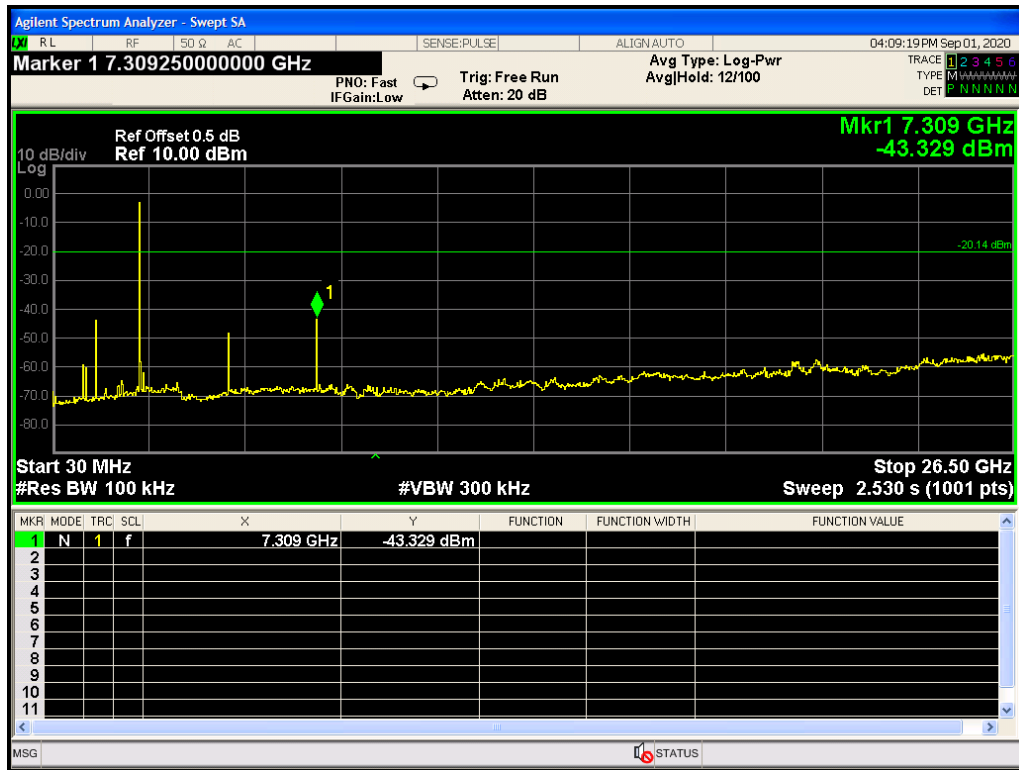

Highest channel (2480MHz)  
30MHz-26.5GHz

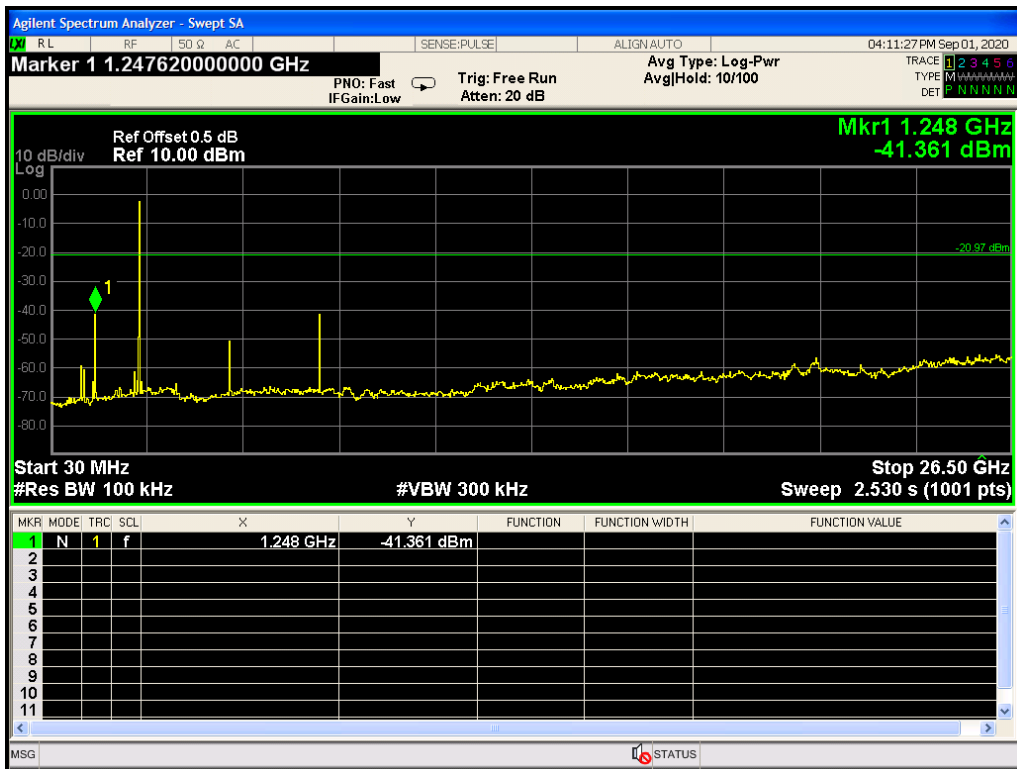

2.475GHz-2.5GHz



## 11. RESTRICTED BANDS OF OPERATION

### 11.1. LIMITS

Section 15.247(d) In addition, Radiated emissions which fall in the restricted bands, as defined in §15.205(a), must also comply with the radiated emission limits specified in §15.209(a) (see §15.205(c)).

MHz	MHz	MHz	GHz
0.090 - 0.110	16.42 - 16.423	399.9 - 410	4.5 - 5.15
<sup>1</sup> 0.495 - 0.505	16.69475 -	608 - 614	5.35 - 5.46
2.1735 - 2.1905	16.69525	960 - 1240	7.25 - 7.75
4.125 - 4.128	16.80425 -	1300 - 1427	8.025 - 8.5
4.17725 - 4.17775	16.80475	1435 - 1626.5	9.0 - 9.2
4.20725 - 4.20775	25.5 - 25.67	1645.5 - 1646.5	9.3 - 9.5
6.215 - 6.218	37.5 - 38.25	1660 - 1710	10.6 - 12.7
6.26775 - 6.26825	73 - 74.6	1718.8 - 1722.2	13.25 - 13.4
6.31175 - 6.31225	74.8 - 75.2	2200 - 2300	14.47 - 14.5
8.291 - 8.294	108 - 121.94	2310 - 2390	15.35 - 16.2
8.362 - 8.366	123 - 138	2483.5 - 2500	17.7 - 21.4
8.37625 - 8.38675	149.9 - 150.05	2655 - 2900	22.01 - 23.12
8.41425 - 8.41475	156.52475 -	3260 - 3267	23.6 - 24.0
12.29 - 12.293	156.52525	3332 - 3339	31.2 - 31.8
12.51975 -	156.7 - 156.9	3345.8 - 3358	36.43 - 36.5
12.52025	162.0125 - 167.17	3600 - 4400	
12.57675 -	167.72 - 173.2		
12.57725	240 - 285		
13.36 - 13.41	322 - 335.4		

### 11.2. TEST PROCEDURES

Test procedures follow KDB 558074 D01 DTS Meas Guidance v03r01.

- 1) The EUT is placed on a turntable, which is 1.5m above the ground plane.
- 2) The turntable shall be rotated for 360 degrees to determine the position of maximum emission level.
- 3) EUT is set 3m away from the receiving antenna, which is varied from 1m to 4m to find out the highest emission.
- 4) Set the spectrum analyzer in the following setting in order to capture the lower and upper band-edges of the emission:
  - a) PEAK: RBW=1MHz / VBW=1MHz / Sweep=AUTO
  - b) AVERAGE: RBW=1MHz / VBW=1/T / Sweep=AUTO
- 5) Repeat the procedures until all the PEAK and AVERAGE versus POLARIZATION are measured.



### 11.3. TEST SETUP

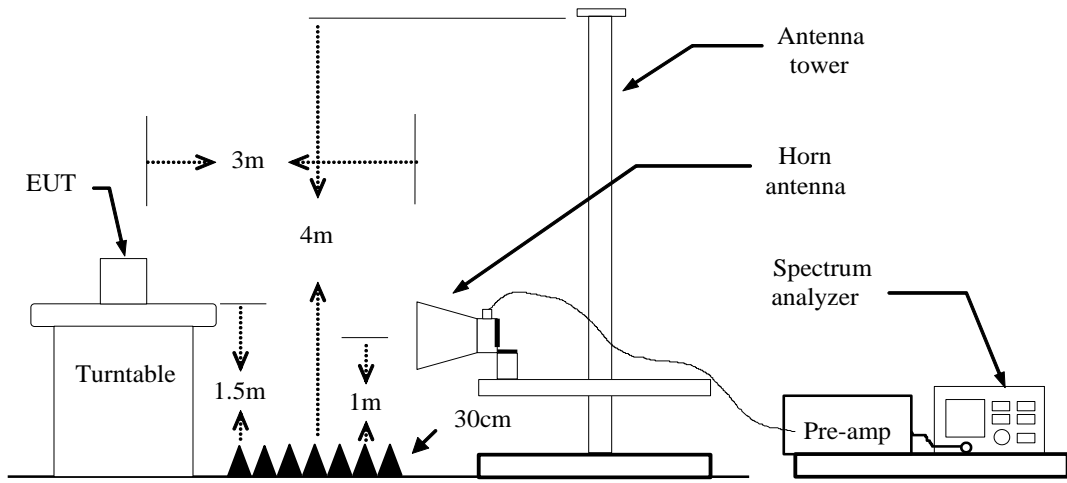

### 11.4. TEST RESULTS

**Lowest Channel**

Channel 2402MHz

Detector mode: Peak

Polarity: Horizontal

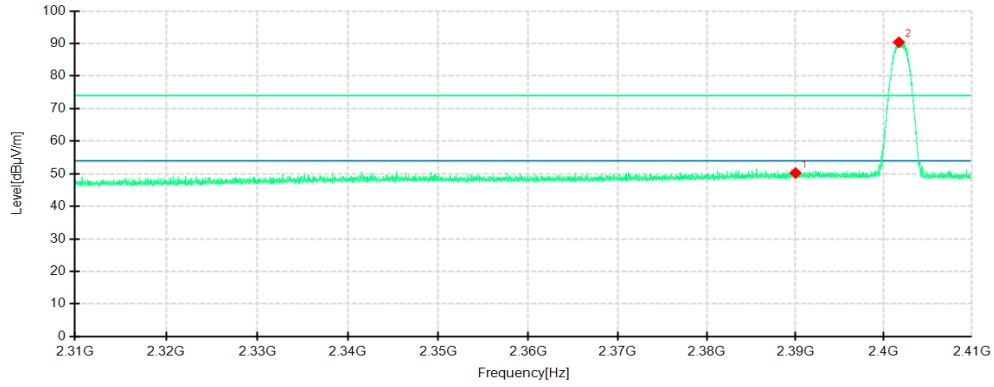

Detector mode: Peak

Polarity: Vertical

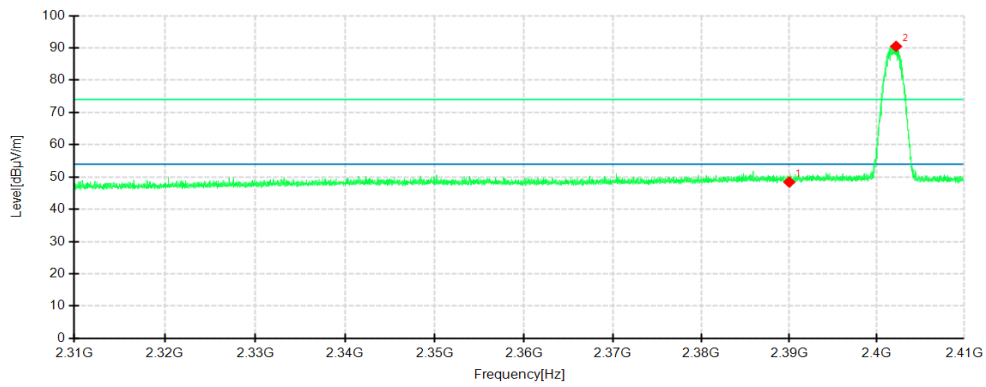

No.	Frequency MHz	Reading dBµV/m	Level dBµV/ m	Factor dB	Limit dBµV/m	Margin dB	Height cm	Angle °	Pole
1	2390.0133	43.39	50.24	6.85	74.00	23.76	150	168	Horizontal
2	2401.7153	83.35	90.38	7.03	74.00	-16.38	150	198	Horizontal
1	2390.0133	41.56	48.41	6.85	74.00	25.59	150	219	Vertical
2	2402.1987	83.47	90.49	7.02	74.00	-16.49	150	206	Vertical

**Lowest Channel**

Channel 2402MHz

Detector mode: Average

Polarity: Horizontal

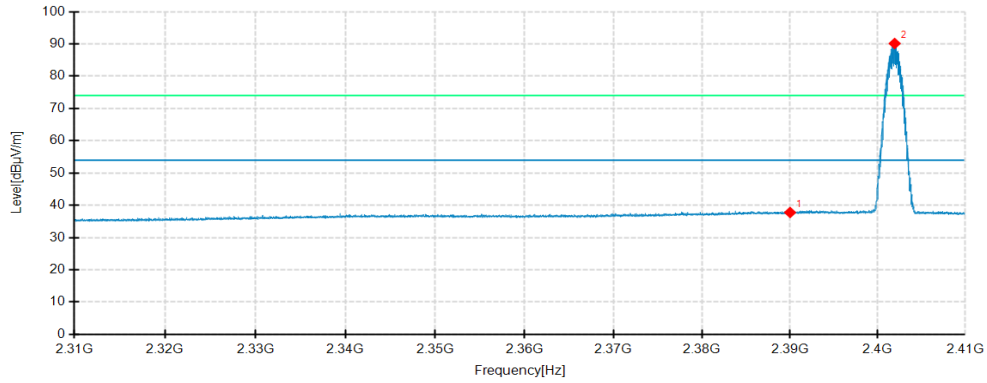

Detector mode: Average

Polarity: Vertical

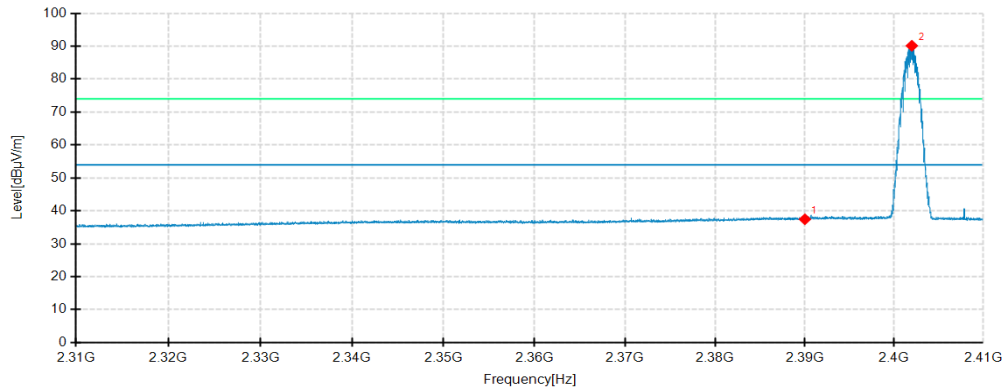

No.	Frequency MHz	Reading dBμV/m	Level dBμV/m	Factor dB	Limit dBμV/m	Margin dB	Height cm	Angle °	Pole
1	2390.0133	30.92	37.77	6.85	54.00	16.23	150	106	Horizontal
2	2401.9320	83.10	90.13	7.03	54.00	-36.13	150	205	Horizontal
1	2390.0133	30.60	37.45	6.85	54.00	16.55	150	194	Vertical
2	2401.9820	83.11	90.13	7.02	54.00	-36.13	150	207	Vertical

**Highest Channel**

Channel 2480MHz

Detector mode: Peak

Polarity: Horizontal

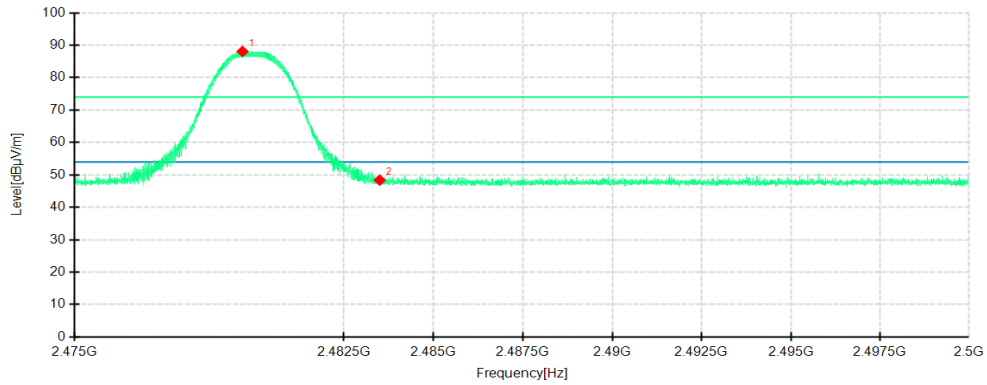

Detector mode: Peak

Polarity: Vertical

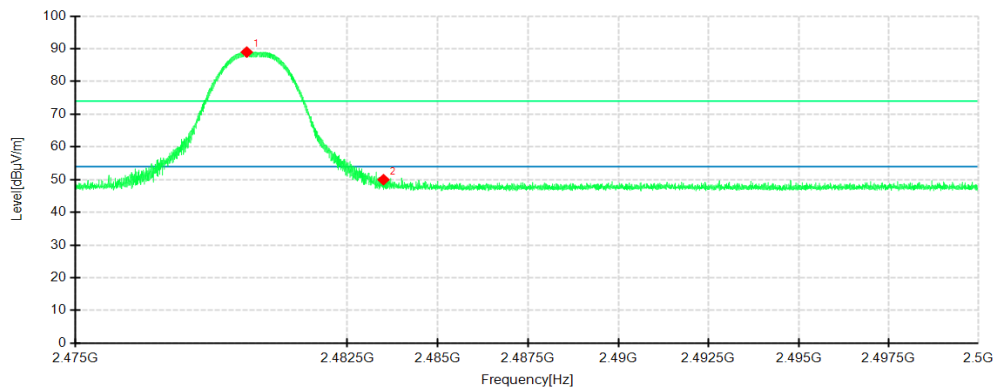

No.	Frequency MHz	Reading dBµV/m	Level dBµV/ m	Factor dB	Limit dBµV/m	Margin dB	Height cm	Angle °	Pole
1	2479.6758	82.44	88.07	5.63	74.00	-14.07	150	172	Horizontal
2	2483.5014	42.81	48.37	5.56	74.00	25.63	150	50	Horizontal
1	2479.7258	83.36	88.98	5.62	74.00	-14.98	150	214	Vertical
2	2483.5014	44.43	49.99	5.56	74.00	24.01	150	202	Vertical

**Highest Channel**

Channel 2480MHz

Detector mode: Average

Polarity: Horizontal

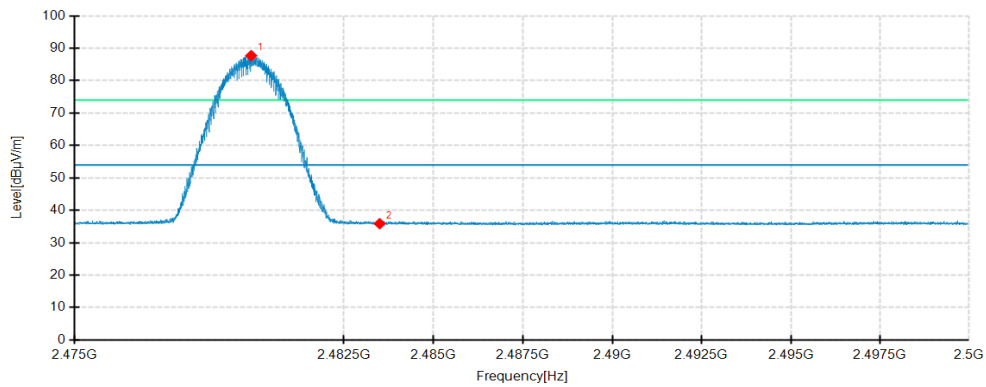

Detector mode: Average

Polarity: Vertical

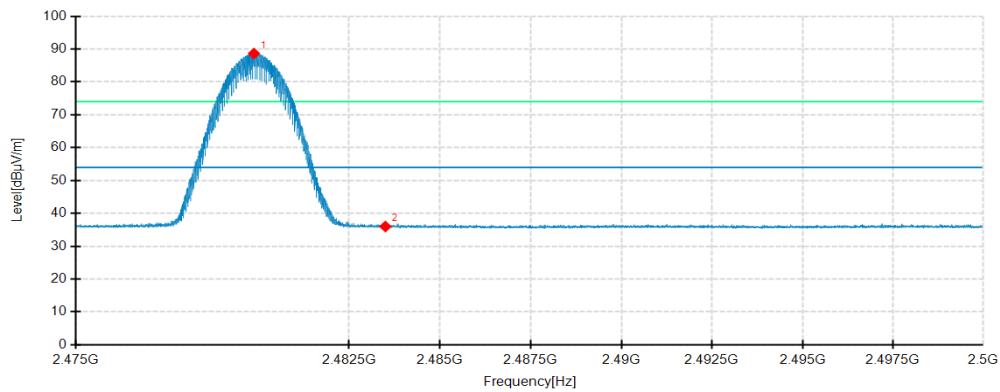

No.	Frequency MHz	Reading dBµV/m	Level dBµV/ m	Factor dB	Limit dBµV/m	Margin dB	Height cm	Angle °	Pole
1	2479.9175	82.07	87.69	5.62	54.00	-33.69	150	174	Horizontal
2	2483.5014	30.31	35.87	5.56	54.00	18.13	150	186	Horizontal
1	2479.8883	83.01	88.63	5.62	54.00	-34.63	150	217	Vertical
2	2483.5014	30.44	36.00	5.56	54.00	18.00	150	187	Vertical

Remark: Max field strength in 3m distance. No any other emission which falls in restricted bands can be detected and be reported.

-----This is the last page of the report. -----