



### FCC - TEST REPORT

Report Number : **68.950.18.0481.01** Date of Issue: November 16, 2018

Model : **C1**

Product Type : Puppy Cube

Applicant : Guangzhou Puppy Robotics Co., Ltd.

Address : Room 4001, No.16, Huaxia Road, Tianhe District, Guangzhou,  
Guangdong, P.R.China

Manufacturer : Guangzhou Puppy Robotics Co., Ltd.

Address : Room 4001, No.16, Huaxia Road, Tianhe District, Guangzhou,  
Guangdong, P.R.China

Test Result :  **Positive**       **Negative**

Total pages including Appendices : 30

*TÜV SÜD Certification and Testing (China) Co., Ltd. Shenzhen Branch is a subcontractor to TÜV SÜD Product Service GmbH according to the principles outlined in ISO 17025.*

*TÜV SÜD Certification and Testing (China) Co., Ltd. Shenzhen Branch reports apply only to the specific samples tested under stated test conditions. Construction of the actual test samples has been documented. It is the manufacturer's responsibility to assure that additional production units of this model are manufactured with identical electrical and mechanical components. The manufacturer/importer is responsible to the Competent Authorities in Europe for any modifications made to the production units which result in non-compliance to the relevant regulations. TÜV SÜD Certification and Testing (China) Co., Ltd. Shenzhen Branch shall have no liability for any deductions, inferences or generalizations drawn by the client or others from TÜV SÜD Certification and Testing (China) Co., Ltd. Shenzhen Branch issued reports.*

*This report is the confidential property of the client. As a mutual protection to our clients, the public and ourselves, extracts from the test report shall not be reproduced except in full without our written approval.*



# 1 Table of Contents

- 1 Table of Contents..... 2
- 2 Details about the Test Laboratory ..... 3
- 3 Summary of Test Standards ..... 4
- 4 Summary of Test Results ..... 5
- 5 Description of the Equipment under Test..... 6
- 6 Systems test configuration..... 7
  - 6.1 Auxiliary Equipment Used during Test: ..... 7
  - 6.2 Test software information:..... 7
  - 6.3 Customized Configurations..... 7
  - 6.4 Test Environments..... 7
- 7 General Remarks..... 8
- 8 Technical Requirement..... 9
  - 8.1 Conducted Emission ..... 9
  - 8.2 Conducted Peak output power ..... 10
  - 8.3 6dB bandwidth ..... 11
  - 8.4 99% bandwidth ..... 12
  - 8.5 Power spectral density ..... 13
  - 8.6 Spurious RF conducted emissions..... 14
  - 8.7 Band edge ..... 15
  - 8.8 Spurious radiated emissions for transmitter ..... 16
- 9 Test Equipment List..... 20
- 10 System Measurement Uncertainty ..... 21



## 2 Details about the Test Laboratory

### Details about the Test Laboratory

#### Test Site 1

Company name: TÜV SÜD Certification and Testing (China) Co., Ltd. Shenzhen Branch  
Building 12&13, Zhiheng Wisdomland Business Park,  
Nantou Checkpoint Road 2, Nanshan District,  
Shenzhen City, 518052,  
P. R. China

Telephone: 86 755 8828 6998

Fax: 86 755 8828 5299

FCC Test Site 514049  
Registration  
Number:

IC Test Site 10320A-1  
Registration  
Number:



### 3 Summary of Test Standards

Test Standards	
FCC Part 15 Subpart C 10-1-2017 Edition	PART 15 - RADIO FREQUENCY DEVICES Subpart C - Intentional Radiators

#### Test Method

- 1: ANSI C63.4-2014, American National Standard for Methods of Measurement of Radio-Noise Emissions from Low-Voltage Electrical and Electronic Equipment in the Range of 9 kHz to 40 GHz.
- 2: ANSI C63.10-2013, American National Standard for Testing Unlicensed Wireless Devices.
- 3: KDB 558074 D01 15.247 Meas Guidance V05.



#### 4 Summary of Test Results

Technical Requirements				
FCC Part 15 Subpart C				
Test Condition		Test Result	Verdict	Test Site
§15.207	Conducted emission AC power port	Appendix G	Pass	Site 1
§15.247(b)(1)	Conducted output power for FHSS	--	N/A	--
§15.247(b)(3)	Conducted output power for DTS	Appendix C	Pass	Site 1
§15.247(e)	Power spectral density	Appendix D	Pass	Site 1
§15.247(a)(2)	6dB bandwidth	Appendix A	Pass	Site 1
§15.247(a)(1)	20dB Occupied bandwidth	--	N/A	--
--	99% Occupied Bandwidth	Appendix B	Pass	Site 1
§15.247(a)(1)	Carrier frequency separation	--	N/A	--
§15.247(a)(1)(iii)	Number of hopping frequencies	--	N/A	--
§15.247(a)(1)(iii)	Dwell Time	--	N/A	--
§15.247(d)	Spurious RF conducted emissions	Appendix F	Pass	Site 1
§15.247(d)	Band edge	Appendix E	Pass	Site 1
§15.247(d) & §15.209 & §15.205	Spurious radiated emissions for transmitter	See page 19	Pass	Site 1
§15.203	Antenna requirement	See note 1	Pass	--

Remark 1: N/A – Not Applicable.

Note 1: The EUT uses an Integrated Metal Antenna, the antenna gain:3.6dBi. According to §15.203, it is considered sufficiently to comply with the provisions of this section.

## 5 Description of the Equipment under Test

Product:	Puppy Cube
Model no.:	C1
FCC ID:	2ARDX-PAIPMSVT01
Rating:	11.1Vdc, 4900mAh (supplied by an internal rechargeable battery Pack) or 19Vdc, 3A (Supplied by an External adapter, Model: NSA60ED-190300 Input: 100-240VAC, 50/60Hz, 1.5A Output: 19VDC, 3.0A)
RF Transmission Frequency:	2402MHz-2480MHz
No. of Operated Channel:	40
Modulation:	GFSK
Antenna Type:	Integrated Antenna
Antenna Gain:	3.6dBi for 2.4GHz
Description of the EUT:	The Equipment Under Test (EUT) is a Puppy Cube supports 2.4GHz Bluetooth/Wi-Fi, 5GHz Wi-Fi functions.

## 6 Systems test configuration

### 6.1 Auxiliary Equipment Used during Test:

DESCRIPTION	MANUFACTURER	MODEL NO.	S/N
LAPTOP	LENOVO	T400	2768L54

### 6.2 Test software information:

Test Software Version	SecureCRT		
Modulation	Setting TX Power	TX Pattern	Packet Type
GFSK	1e	20 03 00/13/27 25 00	

### 6.3 Customized Configurations

EUT Conf.	Signal Description	Operating Frequency	Duty Cycle
Ch0	GFSK	Ch No. 0 / 2402 MHz	/
Ch19	GFSK	Ch No. 19 / 2440 MHz	/
Ch39	GFSK	Ch No. 39 / 2480 MHz	/

### 6.4 Test Environments

Enviroment Parameter	Temperature	Voltage	Relative Humidity
NVLV	25.6°C	11.1VDC	56.4%



## 7 General Remarks

### Remarks

This submittal(s) (test report) is intended for FCC ID: 2ARDX-PAIPMSVT01, complies with Section 15.207, 15.209, 15.205, 15.247 of the FCC Part 15, Subpart C.

The Model: C1 supports Bluetooth BR+EDR/Bluetooth Low Energy/Wi-Fi functions, the TX and RX range is 2402MHz-2480MHz for Bluetooth, 2412MHz – 2462MHz for 2.4GHz Wi-Fi, 5180MHz – 5320MHz, 5500MHz – 5700MHz, 5745MHz – 5825MHz for 5GHz Wi-Fi.

This report is for the Bluetooth Low Energy part.

### SUMMARY:

All tests according to the regulations cited on page 5 were

- Performed

- **Not** Performed

The Equipment under Test

- **Fulfills** the general approval requirements.

- **Does not** fulfill the general approval requirements.

Sample Received Date: October 25, 2018

Testing Start Date: October 25, 2018

Testing End Date: November 15, 2018

- TÜV SÜD Certification and Testing (China) Co., Ltd. Shenzhen Branch –

Reviewed by:

Prepared by:

Tested by:

Laurent Yuan  
EMC Project Manager



Aaron Lai  
EMC Project Engineer

Louise Liu  
EMC Test Engineer



## 8 Technical Requirement

### 8.1 Conducted Emission

**Test Method:**

1. The EUT was placed on a table, which is 0.8m above ground plane
2. The power line of the EUT is connected to the AC mains through a Artificial Mains Network (A.M.N.).
3. Maximum procedure was performed to ensure EUT compliance
4. A EMI test receiver is used to test the emissions from both sides of AC line

**Test Setup:**

The mains cable of the EUT (per AC/DC Adapter) must be connected to LISN. The LISN shall be placed 0.8 m from the boundary of EUT and bonded to a ground reference plane for LISN mounted on top of the ground reference plane. This distance is between the closest points of the LISN and the EUT. All other units of the EUT and associated equipment shall be at least 0.8m from the LISN.

Ground connections, where required for safety purposes, shall be connected to the reference ground point of the LISN and, where not otherwise provided or specified by the manufacturer, shall be of same length as the mains cable and run parallel to the mains connection at a separation distance of not more than 0.1 m.

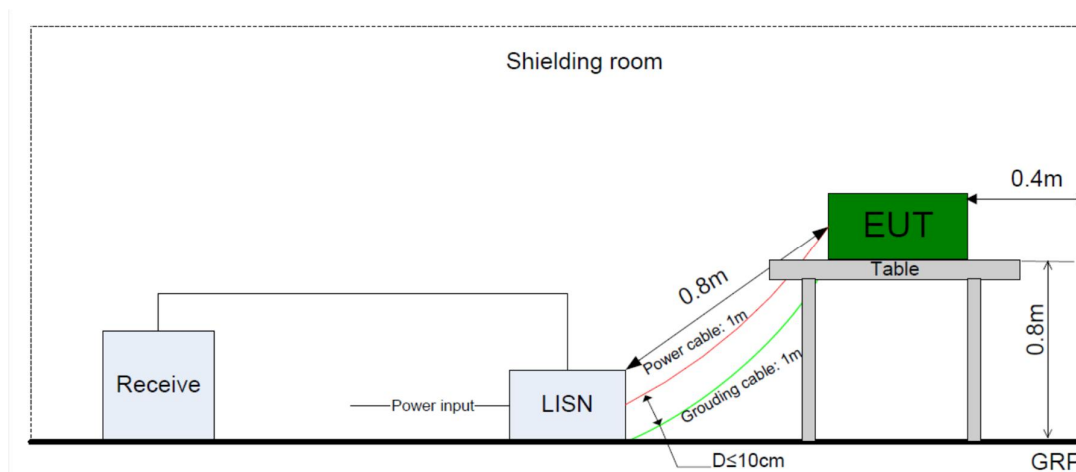

**Limit:**

Frequency MHz	QP Limit dBµV	AV Limit dBµV
0.150-0.500	66-56*	56-46*
0.500-5	56	46
5-30	60	50

Decreasing linear.

**Test Result: Pass**

## 8.2 Conducted Peak output power

### Test Method:

1. Connect EUT test port to spectrum analyzer.
2. Set the EUT to transmit maximum output power at 2.4GHz.
3. Then set the EUT to transmit at high, middle and low frequency and measure the conducted output power separately.
4. Repeat above procedures until all frequencies measured were complete.

### Test Setup:

The Bluetooth component's antenna ports(s) of the EUT are connected to the measurement instrument per an appropriate attenuator. The EUT is controlled by PC/software to emit the specified signals for the purpose of measurements.

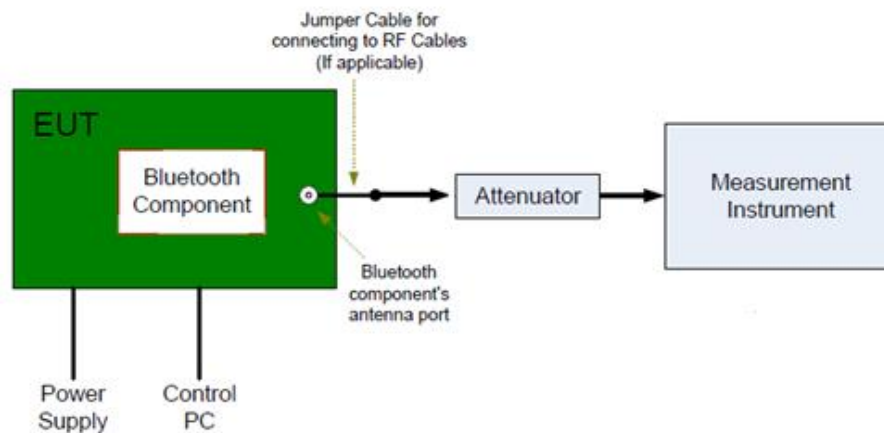

### Limits:

According to §15.247 (b) (3), conducted output power limit as below:

Frequency Range MHz	Limit W	Limit dBm
2400-2483.5	≤1	≤30

**Test Result: Pass**

### 8.3 6dB bandwidth

**Test Method:**

1. Connect EUT test port to spectrum analyzer.
2. Set the EUT to transmit maximum output power at 2.4GHz.
3. Then set the EUT to transmit at high, middle and low frequency and measure the conducted output power separately.
4. RBW=100K, VBW≥3RBW, Sweep = auto, Detector function = peak, Trace = max hold
5. Use the automatic bandwidth measurement capability of an instrument, may be employed using the X dB bandwidth mode with X set to 6 dB, care shall be taken so that the bandwidth measurement is not influenced by any intermediate power nulls in the fundamental emission that might be ≥ 6 dB.
6. Allow the trace to stabilize, record the X dB Bandwidth value.

**Test Setup:**

The Bluetooth component’s antenna ports(s) of the EUT are connected to the measurement instrument per an appropriate attenuator. The EUT is controlled by PC/software to emit the specified signals for the purpose of measurements.

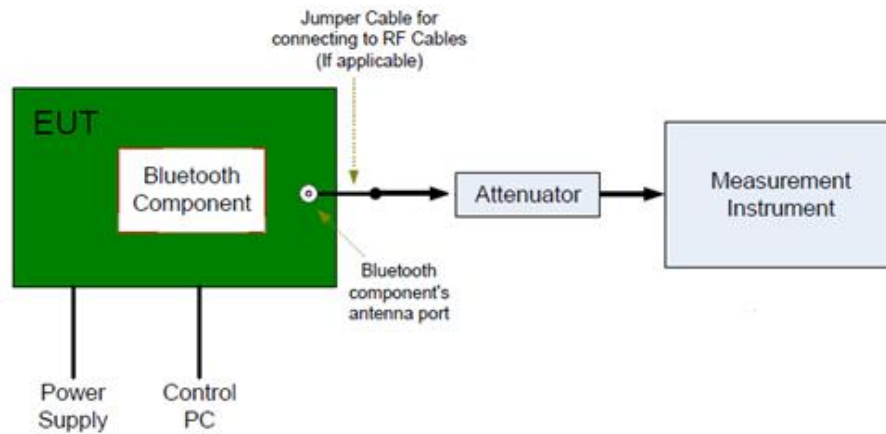

**Limit:**

Limit [kHz]

≥500

**Test Result: Pass**

### 8.4 99% bandwidth

**Test Method:**

1. Connect EUT test port to spectrum analyzer.
2. Set the EUT to transmit maximum output power at 2.4GHz.
3. Then set the EUT to transmit at high, middle and low frequency separately.
4. Set Span = approximately 2 to 3 times the 99% bandwidth, centered on a hopping channel.
5. Set RBW  $\geq$  1% of the 99% bandwidth, VBW  $\geq$  RBW.
6. Set Sweep = auto.
7. Set Detector function = peak.
8. Allow the trace to stabilize.
9. Repeat above procedures until all frequencies measured were complete.

**Test Setup:**

The Bluetooth component's antenna ports(s) of the EUT are connected to the measurement instrument per an appropriate attenuator. The EUT is controlled by PC/software to emit the specified signals for the purpose of measurements.

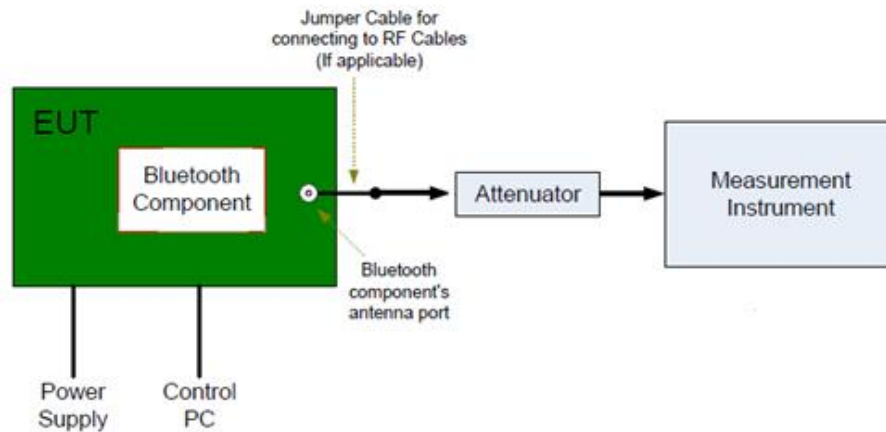

**Limit:**

Limit [kHz]

---

--

**Test Result: Pass**

### 8.5 Power spectral density

**Test Method:**

1. Connect EUT test port to spectrum analyzer.
2. Set the EUT to transmit maximum output power at 2.4GHz.
3. Then set the EUT to transmit at high, middle and low frequency separately.
4. Set analyzer center frequency to DTS channel center frequency.
5. Set the span to 1.5DTS bandwidth, set the RBW to:  $3\text{ kHz} \leq \text{RBW} \leq 100\text{ kHz}$ , set the  $\text{VBW} \geq 3\text{RBW}$ .
6. Detector = peak.
7. Sweep time = auto couple.
8. Trace mode = max hold.
9. Allow trace to fully stabilize.
10. Use the peak marker function to determine the maximum amplitude level within the RBW.
11. If measured value exceeds limit, reduce RBW (no less than 3 kHz) and repeat.

**Test Setup:**

The Bluetooth component's antenna ports(s) of the EUT are connected to the measurement instrument per an appropriate attenuator. The EUT is controlled by PC/software to emit the specified signals for the purpose of measurements.

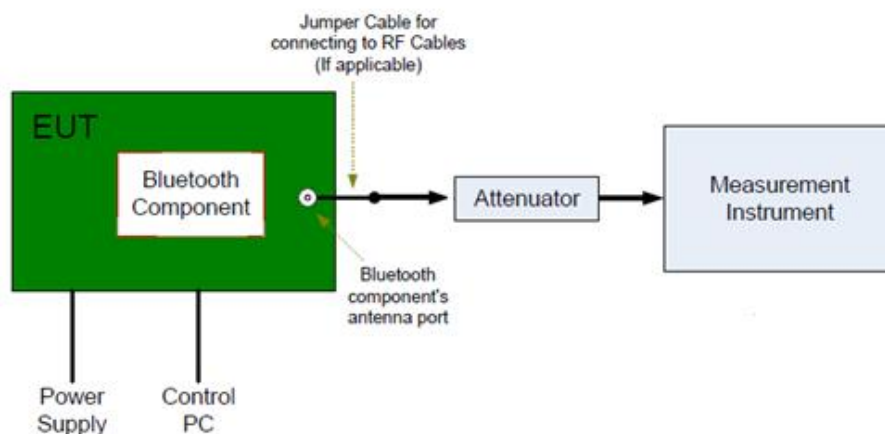

**Limit:**

Limit [dBm]

\_\_\_\_\_

$\leq 8$

**Test Result: Pass**

## 8.6 Spurious RF conducted emissions

### Test Method:

1. Connect EUT test port to spectrum analyzer.
2. Set the EUT to transmit maximum output power at 2.4GHz.
3. Then set the EUT to transmit at high, middle and low frequency separately.
4. Set Span = wide enough to capture the peak level of the emission operating on the channel closest to the band edge, as well as any modulation products which fall outside of the authorized band of operation.
5. Set RBW = 100 kHz, VBW ≥ RBW.
6. Set Sweep = auto.
7. Set Detector function = peak.
8. Allow the trace to stabilize.
9. Repeat above procedures until all frequencies measured were complete.

### Test Setup:

The Bluetooth component's antenna ports(s) of the EUT are connected to the measurement instrument per an appropriate attenuator. The EUT is controlled by PC/software to emit the specified signals for the purpose of measurements.

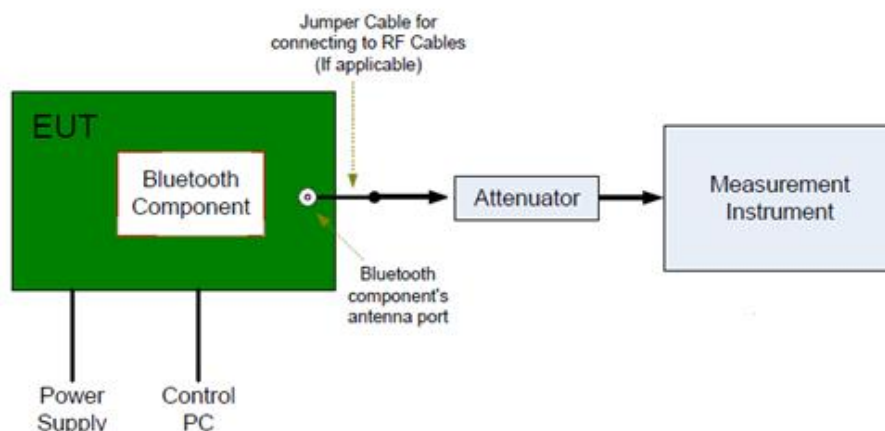

### Limit:

Frequency Range MHz	Limit (dBc)
30-25000	-20

**Test Result: Pass**

## 8.7 Band edge

### Test Method:

1. Connect EUT test port to spectrum analyzer.
2. Set the EUT to transmit maximum output power at 2.4GHz.
3. Then set the EUT to transmit at high, middle and low frequency separately.
4. Set Span = wide enough to capture the peak level of the emission operating on the channel closest to the band edge, as well as any modulation products which fall outside of the authorized band of operation.
5. Set RBW  $\geq$  1% of the span, VBW  $\geq$  RBW.
6. Set Sweep = auto.
7. Set Detector function = peak.
8. Allow the trace to stabilize.
9. Repeat above procedures until all frequencies measured were complete.

### Test Setup:

The Bluetooth component's antenna ports(s) of the EUT are connected to the measurement instrument per an appropriate attenuator. The EUT is controlled by PC/software to emit the specified signals for the purpose of measurements.

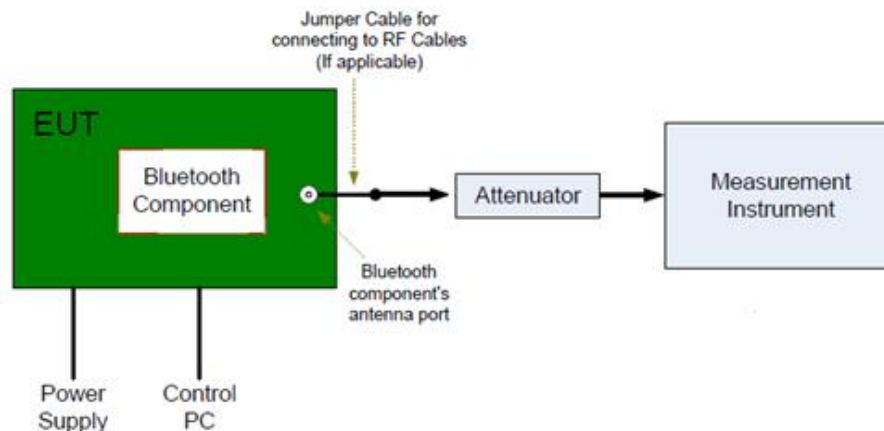

### Limit:

In any 100kHz bandwidth outside the frequency band in which the spread spectrum or digitally modulated device is operating, the RF power that is produced shall be at least 20 dB below that in the 100 kHz bandwidth within the band that contains the highest level of the desired power, based on either an RF conducted or a radiated measurement, provided that the transmitter demonstrates compliance with the peak conducted power limits.

### Test Result: Pass

## 8.8 Spurious radiated emissions for transmitter

### Test Method:

1: The EUT was placed on a turn table which is 1.5m above ground plane for above 1GHz and 0.8m above ground for below 1GHz at 3 meter chamber room for test. The table was rotated 360 degrees to determine the position of the highest radiation.

2: The EUT was set 3 meters away from the interference – receiving antenna, which was mounted on the top of a variable – height antenna tower.

3: The height of antenna is varied from one meter to four meters above the ground to determine the maximum value of the field strength. Both horizontal and vertical polarizations of the antenna are set to make the measurement.

4: For each suspected emission, the EUT was arranged to its worst case and then the antenna was tuned to heights from 1 meter to 4 meters and the rotatable table was turned from 0 degrees to 360 degrees to find the maximum reading.

5: Use the following spectrum analyzer settings According to C63.10:

For Above 1GHz

Span = wide enough to capture the peak level of the in-band emission and all spurious  
RBW = 1MHz, VBW $\geq$ RBW for peak measurement and VBW = 10Hz for average measurement, Sweep = auto, Detector function = peak, Trace = max hold.

For Below 1GHz

Use the following spectrum analyzer settings:

Span = wide enough to capture the peak level of the in-band emission and all spurious  
RBW = 100 KHz, VBW $\geq$ RBW for peak measurement, Sweep = auto, Detector function = peak, Trace = max hold.

For Below 30MHz

Use the following spectrum analyzer settings:

Span = wide enough to capture the peak level of the in-band emission and all spurious  
RBW = 200 Hz, VBW $\geq$ RBW from 9KHz to 0.15MHz, RBW 9KHz VBW $\geq$ RBW from 0.15MHz to 30MHz for peak measurement, Sweep = auto, Detector function = peak, Trace = max hold.

### Note:

1: The resolution bandwidth and video bandwidth of test receiver/spectrum analyzer is 120 KHz for Quasi-peak detection (QP) at frequency below 1GHz.

2: The resolution bandwidth of test receiver/spectrum analyzer is 1MHz and the video bandwidth is 3MHz for peak detection (PK) at frequency above 1GHz.

3: The resolution bandwidth of test receiver/spectrum analyzer is 1MHz and the video bandwidth is 3MHz for RMS Average ((duty cycle < 98%) for Average detection (AV) at frequency above 1GHz, then the measurement results was added to a correction factor (20log(1/duty cycle)).

4: The resolution bandwidth of test receiver/spectrum analyzer is 1MHz and the video bandwidth is 10Hz (duty cycle > 98%) for Average detection (AV) at frequency above 1GHz.



**Test Setup:**

**Test Setup:**

**Test Setup 1: Radiated Emission test below 30MHz**

The test site semi-anechoic chamber has met the requirement of NSA tolerance 4 dB according to the standards: ANSI C63.4. The test distance is 3m. The setup is according to ANSI C63.4.

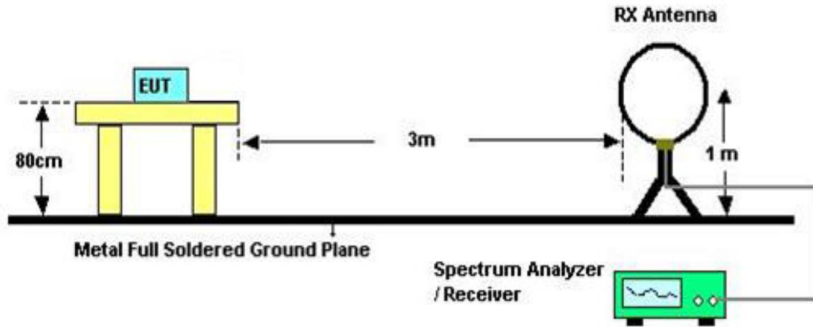

**Test Setup 2: Radiated Emission test below 1GHz**

The test site semi-anechoic chamber has met the requirement of NSA tolerance 4 dB according to the standards: ANSI C63.4. The test distance is 3m. The setup is according to ANSI C63.4.

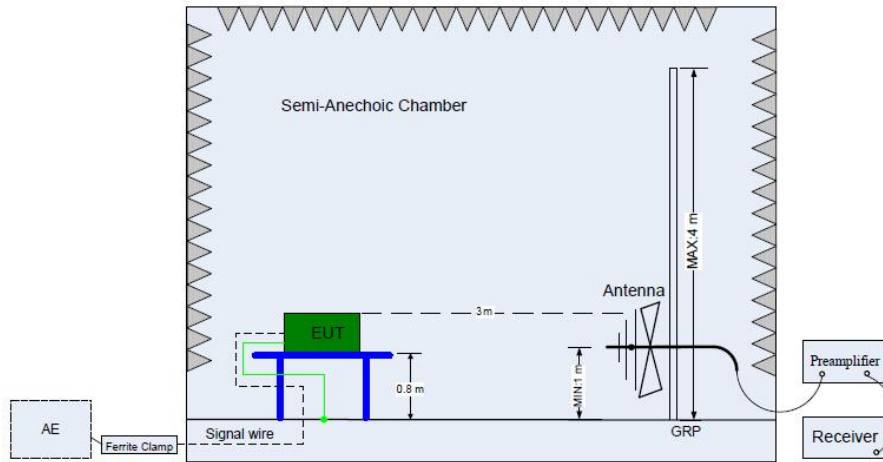

(Below 1 GHz)

**Test Setup 3: Radiated Emission test above 1GHz**

The test site semi-anechoic chamber has met the requirement of NSA tolerance 4 dB according to the standards: ANSI C63.4. The test distance is 3m. The setup is according to ANSI C63.4.

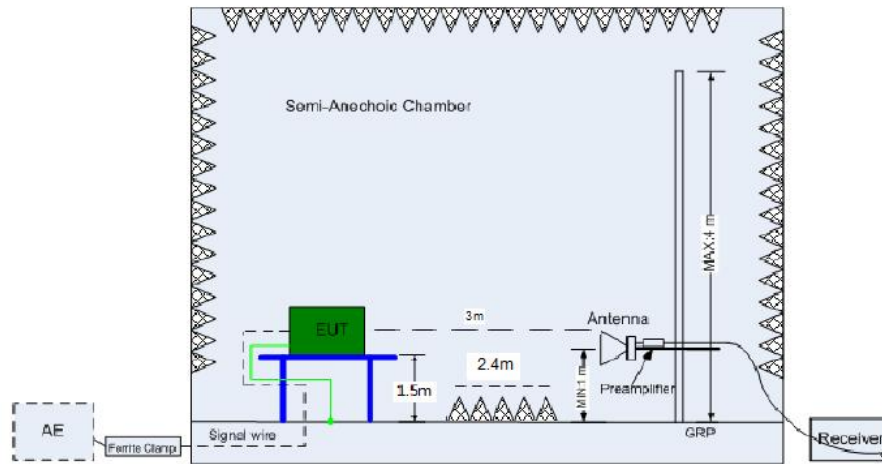

(Above 1 GHz)

**Limit:**

Radiated emissions which fall in the restricted bands, as defined in section 15.205, must comply with the radiated emission limits specified in section 15.209.

§ 15.209

Frequency MHz	Field Strength uV/m	Field Strength dBµV/m	Detector
30-88	100	40	QP
88-216	150	43.5	QP
216-960	200	46	QP
960-1000	500	54	QP
Above 1000	500	54	AV
Above 1000	5000	74	PK

§15.205 Restricted bands of operation

MHz	MHz	MHz	GHz
0.090-0.110	16.42-16.423	399.9-410	4.5-5.15
0.495-0.505	16.69475-16.69525	608-614	5.35-5.46
2.1735-2.1905	16.80425-16.80475	960-1240	7.25-7.75
4.125-4.128	25.5-25.67	1300-1427	8.025-8.5
4.17725-4.17775	37.5-38.25	1435-1626.5	9.0-9.2
4.20725-4.20775	73-74.6	1645.5-1646.5	9.3-9.5
6.215-6.218	74.8-75.2	1660-1710	10.6-12.7
6.26775-6.26825	108-121.94	1718.8-1722.2	13.25-13.4
6.31175-6.31225	123-138	2200-2300	14.47-14.5
8.291-8.294	149.9-150.05	2310-2390	15.35-16.2
8.362-8.366	156.52475-156.52525	2483.5-2500	17.7-21.4
8.37625-8.38675	156.7-156.9	2690-2900	22.01-23.12
8.41425-8.41475	162.0125-167.17	3260-3267	23.6-24.0
12.29-12.293	167.72-173.2	3332-3339	31.2-31.8
12.51975-12.52025	240-285	3345.8-3358	36.43-36.5
12.57675-12.57725	322-335.4	3600-4400	(*)
13.36-13.41			

**Test Result: Pass**

According to C63.10, if the peak (or quasi-peak) measured value complies with the average limit, it is unnecessary to perform an average measurement, so AV emission value did not show in below table if the peak value complies with average limit.

#### GFSK Modulation 2402MHz Test Result

Frequency Band	Frequency	Emission Level	Polarization	Limit	Detector	Margin	Corr.	Result
	MHz	dBuV/m		dBuV/m		dB	(dB)	
30-1000MHz	840.00	37.40	H	46.00	QP	8.60	-16.3	Pass
	891.41	35.74	V	46.00	QP	10.26	-15.5	Pass
1000-25000MHz	7511.71*	42.14	H	74.00	PK	31.86	9.5	Pass
	--	--	H	54.00	AV	--	--	Pass
	4804.20*	42.84	V	74.00	PK	31.16	3.7	Pass
	--	--	V	54.00	AV	--	--	Pass

#### GFSK Modulation 2441MHz Test Result

Frequency Band	Frequency	Emission Level	Polarization	Limit	Detector	Margin	Corr.	Result
	MHz	dBuV/m		dBuV/m		dB	(dB)	
30-1000MHz	--	--	H	43.50	QP	--	--	Pass
	--	--	V	46.00	QP	--	--	Pass
1000-25000MHz	7601.25*	41.79	H	74.00	PK	32.21	9.9	Pass
	--	--	H	54.00	AV	--	--	Pass
	4803.75*	43.10	V	74.00	PK	30.90	3.7	Pass
	--	--	V	54.00	AV	--	--	Pass

#### GFSK Modulation 2480MHz Test Result

Frequency Band	Frequency	Emission Level	Polarization	Limit	Detector	Margin	Corr.	Result
	MHz	dBuV/m		dBuV/m		dB	(dB)	
30-1000MHz	--	--	H	43.50	QP	--	--	Pass
	--	--	V	46.00	QP	--	--	Pass
1000-25000MHz	7519.21*	43.45	H	74.00	PK	30.55	9.6	Pass
	--	--	H	54.00	AV	--	--	Pass
	4803.28*	44.33	V	74.00	PK	29.67	3.7	Pass
	--	--	V	54.00	AV	--	--	Pass

#### Remark:

- (1) "\*" means the emission(s) appear within the restrict bands shall follow the requirement of section 15.205.
- (2) Data of measurement within this frequency range shown "--" in the table above means the reading of emissions are the noise floor or attenuated more than 10dB below the permissible limits or the field strength is too small to be measured.
- (3) Above 1GHz: Corrector factor = Antenna Factor + Cable Loss- Amplifier Gain.
- (4) Below 1GHz: Corrector factor = Antenna Factor + Cable Loss.
- (5) The low frequency, which started from 9 kHz to 30MHz, was pre-scanned and the result which was 20dB lower than the limit line per 15.31(o) was not reported.

## 9 Test Equipment List

### Radiated Emission Test

DESCRIPTION	MANUFACTURER	MODEL NO.	SERIAL NO.	CAL. DUE DATE
EMI Test Receiver	Rohde & Schwarz	ESR 26	101269	2019-7-6
Trilog Super Broadband Test Antenna	Schwarzbeck	VULB 9163	707	2019-6-28
Horn Antenna	Rohde & Schwarz	HF907	102294	2019-6-28
Pre-amplifier	Rohde & Schwarz	SCU 18	102230	2019-7-6
Signal Generator	Rohde & Schwarz	SMY01	839369/005	2019-7-6
Attenuator	Agilent	8491A	MY39264334	2019-7-6
3m Semi-anechoic chamber	TDK	9X6X6	----	2020-7-7
Test software	Rohde & Schwarz	EMC32	Version 9.15.00	N/A

### Conducted Emission Test

DESCRIPTION	MANUFACTURER	MODEL NO.	SERIAL NO.	CAL. DUE DATE
EMI Test Receiver	Rohde & Schwarz	ESR 3	101782	2019-7-6
LISN	Rohde & Schwarz	ENV4200	100249	2019-7-6
LISN	Rohde & Schwarz	ENV432	101318	2019-7-6
LISN	Rohde & Schwarz	ENV216	100326	2019-7-6
ISN	Rohde & Schwarz	ENY81	100177	2019-7-6
ISN	Rohde & Schwarz	ENY81-CA6	101664	2019-7-6
High Voltage Probe	Rohde & Schwarz	TK9420(VT9420)	9420-584	2019-6-30
RF Current Probe	Rohde & Schwarz	EZ-17	100816	2019-6-30
Attenuator	Shanghai Huaxiang	TS2-26-3	080928189	2019-7-6
Test software	Rohde & Schwarz	EMC32	Version 9.15.00	N/A

### TS8997 Test System

DESCRIPTION	MANUFACTURER	MODEL NO.	SERIAL NO.	CAL. DUE DATE
Signal Generator	Rohde & Schwarz	SMB100A	108272	2019-7-6
Vector Signal Generator	Rohde & Schwarz	SMBV100A	262825	2019-7-6
Communication Synthetical Test Instrument	Rohde & Schwarz	CMW 270	101251	2019-5-31
Signal Analyzer	Rohde & Schwarz	FSV40	101030	2019-7-6
Vector Signal Generator	Rohde & Schwarz	SMU 200A	105324	2019-7-6
RF Switch Module	Rohde & Schwarz	OSP120/OSP-B157	101226/100851	2019-7-6
Power Splitter	Weinschel	1580	SC319	2019-7-5
10dB Attenuator	Weinschel	4M-10	43152	2019-7-6
10dB Attenuator	R&S	DNF	DNF-001	2019-7-6
10dB Attenuator	R&S	DNF	DNF-002	2019-7-6
10dB Attenuator	R&S	DNF	DNF-003	2019-7-6
10dB Attenuator	R&S	DNF	DNF-004	2019-7-6
Test software	Rohde & Schwarz	EMC32	Version 10.38.00	N/A
Test software	Tonscend	System for BT/WIFI	Version 2.6	N/A



## 10 System Measurement Uncertainty

For a 95% confidence level, the measurement expanded uncertainties for defined systems, in accordance with the recommendations of ISO 17025 were:

System Measurement Uncertainty	
Items	Extended Uncertainty
Uncertainty for Radiated Spurious Emission 25MHz-3000MHz	Horizontal: 4.80dB; Vertical: 4.87dB;
Uncertainty for Radiated Spurious Emission 3000MHz-18000MHz	Horizontal: 4.59dB; Vertical: 4.58dB;
Uncertainty for Radiated Spurious Emission 18000MHz-40000MHz	Horizontal: 5.05dB; Vertical: 5.04dB;
Uncertainty for Conducted RF test with TS 8997	Power level test involved: 2.13dB Frequency test involved: $0.6 \times 10^{-7}$
Uncertainty for Conducted Emission 150kHz-30MHz (for test using AMN ENV432 or ENV4200)	3.21dB