

# SPECIFICATION FOR APPROVAL

## 1. MECHANICAL DIMENSION (UNIT:mm)

## 2. SCHEMATICS:

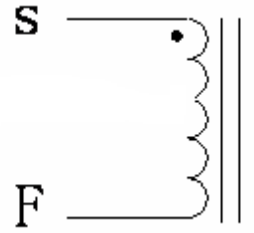
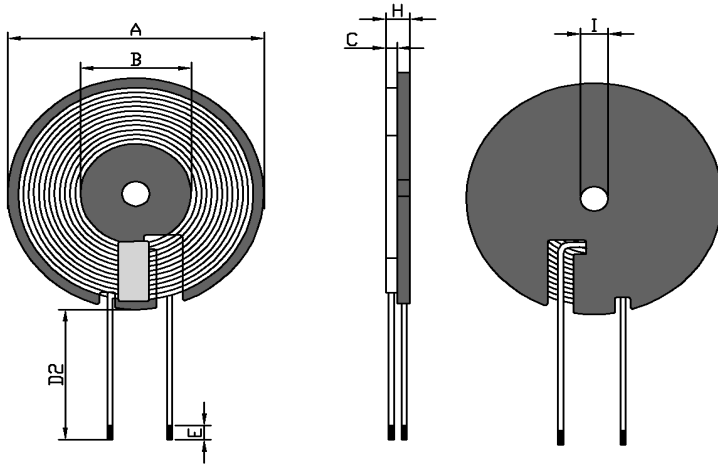

A	B	C	D2	E	H				I
43.5±0.05	20.5±0.5	0.65±0.05	50±3	3±2	2.1MAX				

## 3. WINDING:

STEP	START-FINISH	WIRE TYPE	TURNS	TAPE	REMARK
N1	S-F	Hot air wire 0.08*80 2UEW	10TS (Ref)		

## 4. ELECTRICAL SPECIFICATION:

ITEM	L	DCR		HI-POT
TEST	Coil and diskette	S-F		
CON	100KHz, 0.25V	AT 25°C		
SPEC	6.5uH±10%	65mΩ Max		

## 5. BILF OF MATERIAL:

NO.	ITEM	MATERIAL SPECIFICATION	MANUFACTURER	SGS NO.
1	Hot air wire 0.08*80	Hot air wire 0.08*80	NANJINGJINNINGCO,LTD	
2	Lead-free tin strip	Lead-free tin strip	QIAODO	
3	Magnetic sheet	43.5*0.65Manganese zinc hard disk with L slot	TAIYI CO.,LTD	
4	glue	Yellow gum 9999	LIANCHENG CO.,LTD	
5	High-temperature adhesive paper	8mm Wide high temperature adhesive paper	CUDAK CO.,LTD	
6	Rubber backing	41.8*0.1	CUDAK CO.,LTD	
7				

HRSW ELECTRONICS CO.,LTD		PART NO	
		TITLE	G43.5 magnetic /0.65 thick 80 strands 50 length
DRAWN BY	CHECKED BY		APPROVED BY
He Weihua	Wei Lihong		Wei Lihong