



RADIO TEST REPORT

Report No.: STS1806066W01

Issued for

PerimeterSafe Home Monitoring Limited

The Atrium, 1321 Blanshard Street, Suite 301 Victoria, British Columbia, BC V8W 0B6, Canada

Product Name:	Smart Baby Monitor (Baby Unit)
Brand Name:	Kodak
Model Name:	CHERISH C525BU
Series Model:	CHERISH C225BU
FCC ID:	2APVD-C525BU
IC ID:	23907-C525BU
HVIN:	C525BU
Test Standard:	CFR47 FCC Part 15: Subpart C Section 15.247 CFR47 FCC Part 15: Subpart C Section 15.207 CFR47 FCC Part 15: Subpart C Section 15.209 CFR47 FCC Part 15: Subpart B Section 15.107 CFR47 FCC Part 15: Subpart B Section 15.109
	RSS-247 Issue 2 February 2017 RSS-Gen Issue 5 April 2018
	ICES-003 Issue 6 January 2016

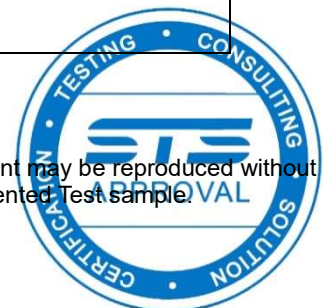

Any reproduction of this document must be done in full. No single part of this document may be reproduced without permission from STS, All Test Data Presented in this report is only applicable to presented Test sample.



TEST RESULT CERTIFICATION

Applicant's name : **PerimeterSafe Home Monitoring Limited**
Address : The Atrium, 1321 Blanshard Street, Suite 301 Victoria, British Columbia, BC V8W 0B6, Canada
Manufacture's Name : **Cinatic Technology Limited**
Address : Unit 805, 8/F, Tower3, Phase1, Enterprise Square 9 Sheung Yuet Rd, Kowloon Bay, Kowloon, Hong Kong

Product description

Product Name : Smart Baby Monitor (Baby Unit)
Brand Name : Kodak
Model Name : CHERISH C525BU
Series Model : CHERISH C225BU

Test Standards : CFR47 FCC Part 15: Subpart C Section 15.247
 CFR47 FCC Part 15: Subpart C Section 15.207
 CFR47 FCC Part 15: Subpart C Section 15.209
 CFR47 FCC Part 15: Subpart B Section 15.107
 CFR47 FCC Part 15: Subpart B Section 15.109
 RSS-247 Issue 2 February 2017
 RSS-Gen Issue 5 April 2018
 ICES-003 Issue 6 January 2016

Test procedure : ANSI C63.10: 2013, ANSI C63.4: 2014

This device described above has been tested by STS, the test results show that the equipment under test (EUT) is in compliance with the FCC/IC requirements. And it is applicable only to the tested sample identified in the report.

This report shall not be reproduced except in full, without the written approval of STS, this document only be altered or revised by STS, personal only, and shall be noted in the revision of the document.

Date of Test

Date (s) of performance of tests : 11 Jun. 2018 - 26 Jun. 2018

Date of Issue : 27 Jun. 2018

Test Result : **Pass**

Testing Engineer : Chris Chen
 (Chris Chen)

Technical Manager : Sean She
 (Sean She)

Authorized Signatory : Vita Li
 (Vita Li)





Table of Contents

Page

1	SUMMARY OF TEST RESULTS	6
1.1	TEST FACTORY	7
1.2	MEASUREMENT UNCERTAINTY	7
2	GENERAL INFORMATION	8
2.1	GENERAL DESCRIPTION OF EUT	8
2.2	DESCRIPTION OF TEST MODES	10
2.3	BLOCK DIGRAM SHOWING THE CONFIGURATION OF SYSTEM TESTED	11
2.4	DESCRIPTION OF SUPPORT UNITS	11
2.5	EQUIPMENTS LIST FOR ALL TEST ITEMS	12
3	EMC EMISSION TEST	14
3.1	CONDUCTED EMISSION MEASUREMENT	14
3.2	RADIATED EMISSION MEASUREMENT	20
3.3	RADIATED SPURIOUS EMISSION MEASUREMENT	26
4	CONDUCTED SPURIOUS & BAND EDGE EMISSION	37
4.1	APPLIED PROCEDURES / LIMIT	37
4.2	TEST PROCEDURE	37
4.3	DEVIATION FROM STANDARD	37
4.4	TEST SETUP	37
4.5	EUT OPERATION CONDITIONS	37
4.6	TEST RESULTS	38
5	POWER SPECTRAL DENSITY TEST	50
5.1	APPLIED PROCEDURES / LIMIT	50
5.2	TEST PROCEDURE	50
5.3	DEVIATION FROM STANDARD	50
5.4	TEST SETUP	50
5.5	EUT OPERATION CONDITIONS	50
5.6	TEST RESULTS	51
6	BANDWIDTH TEST	59
6.1	APPLIED PROCEDURES / LIMIT	59
6.2	TEST PROCEDURE	59
6.3	DEVIATION FROM STANDARD	59
6.4	TEST SETUP	59
6.5	EUT OPERATION CONDITIONS	59
6.6	TEST RESULTS	60



- 7 PEAK OUTPUT POWER TEST 68**
 - 7.1 APPLIED PROCEDURES / LIMIT 68
 - 7.2 TEST PROCEDURE 68
 - 7.3 DEVIATION FROM STANDARD 68
 - 7.4 TEST SETUP 68
 - 7.5 EUT OPERATION CONDITIONS 68
 - 7.6 TEST RESULTS 69
- 8 ANTENNA REQUIREMENT 70**
 - 8.1 STANDARD REQUIREMENT 70
 - 8.2 EUT ANTENNA 70
- 9 APPENDIX - PHOTOS OF TEST SETUP 71**





Revision History

Rev.	Issue Date	Report NO.	Effect Page	Contents
00	27 Jun. 2018	STS1806066W01	ALL	Initial Issue





1 SUMMARY OF TEST RESULTS

Test procedures according to the technical standards:

KDB 558074 D01 DTS Meas Guidance v04

FCC Part 15, Subpart C RSS-247 Issue 2			
Standard Section	Test Item	Judgment	Remark
FCC Part 15.207(a) RSS-Gen Clause 8.8	Conducted Emission	PASS	
FCC Part 15.247(a)(2) RSS-247 Clause 5.2(a)	6dB Bandwidth	PASS	
RSS-Gen Clause 6.6	99% Bandwidth	PASS	
FCC Part 15.247(b)(3) RSS-247 Clause 5.4(d)	Output Power	PASS	
FCC Part 15.247(d) RSS-247 Clause 3.3	Radiated Spurious Emission	PASS	
FCC Part 15.247(d) RSS-247 Clause 5.5	Conducted Spurious & Band Edge Emission	PASS	
FCC Part 15.247(e) RSS-247 Clause 5.2(b)	Power Spectral Density	PASS	
FCC Part 15.205	Restricted Band Edge Emission	PASS	
FCC Part 15.247(d) & 15.209(a) RSS-247 Clause 5.5	Band Edge Emission	PASS	
FCC Part 15.247(b)(4) & 15.203	Antenna Requirement	PASS	

FCC Part 15, Subpart B ICES-003 Issue 6			
Standard Section	Test Item	Judgment	Remark
FCC Part 15.107(a) ICES-003	Conducted Emission	PASS	Class B limit
FCC Part 15.109(a) ICES-003	Radiated Emission	PASS	Class B limit

NOTE:

- 1) 'N/A' denotes test is not applicable in this test report
- 2) All tests were performed according to the procedures in ANSI C63.10: 2013 and ANSI C63.4: 2014.



1.1 TEST FACTORY

Shenzhen STS Test Services Co., Ltd.

Add. : 1/F., Building B, Zhuoke Science Park, No.190, Chongqing Road, Fuyong Street, Bao'an District, Shenzhen, Guangdong, China

CNAS Registration No.: L7649

FCC Registration No.: 625569

IC Registration No.: 12108A

A2LA Certificate No.: 4338.01

1.2 MEASUREMENT UNCERTAINTY

The reported uncertainty of measurement $y \pm U$, where expanded uncertainty U is based on a standard uncertainty multiplied by a coverage factor of $k=2$, providing a level of confidence of approximately 95 %.

No.	Item	Uncertainty
1	Conducted Emission (9KHz-150KHz)	$\pm 2.88\text{dB}$
2	Conducted Emission (150KHz-30MHz)	$\pm 2.67\text{dB}$
3	RF power,conducted	$\pm 0.71\text{dB}$
4	Spurious emissions,conducted	$\pm 0.63\text{dB}$
5	All emissions,radiated (9KHz-30MHz)	$\pm 3.02\text{dB}$
6	All emissions,radiated (30MHz-200MHz)	$\pm 3.80\text{dB}$
7	All emissions,radiated (200MHz-1000MHz)	$\pm 3.97\text{dB}$
8	All emissions,radiated(>1G)	$\pm 3.03\text{dB}$



2 GENERAL INFORMATION

2.1 GENERAL DESCRIPTION OF EUT

Product Name	Smart Baby Monitor (Baby Unit)	
Trade Name	Kodak	
Model Name	CHERISH C525BU	
Series Model	CHERISH C225BU	
Model Difference	All models are fully identical except model name.	
Product Description	The EUT is a Smart Baby Monitor (Baby Unit) which supports Wi-Fi 802.11 b/g/n wireless technology.	
	Operation Frequency:	2412 - 2462 MHz for 802.11b/g/n(HT20) 2422 - 2452 MHz for 802.11n(HT40)
	Modulation Type:	DSSS(DBPSK/DQPSK/CCK) OFDM(BPSK/QPSK/16QAM/64QAM)
	Bit Rate of Transmitter:	1/2/5.5/11 Mbps for 802.11b 6/9/12/18/24/36/48/54 Mbps for 802.11g MCS0 ~ MCS7 for 802.11n
	Number Of Channel:	11 channels for 802.11b/g/n(HT20) 7 channels for 802.11n(HT40)
	Antenna Designation:	Please see Note 4
	Antenna Gain (dBi):	0dBi
	Duty Cycle:	>98%
Channel List	Please refer to the Note 2.	
Adapter	Model: TPA-97050150U01 (TianYin) Input: AC 100-240V~50/60Hz, 0.3A Output: DC 5.0V@1500mA	
Battery	Model: I9300 (Tianmao) DC 3.8V@2100mAh/7.98Wh Li-ion battery Limited charge voltage: 4.35V	
Hardware version	N/A	
Software version	N/A	
Radio Hardware version	N/A	
Radio Software version	N/A	
Test Software	SecureCRT	
RF Power Setting TEST Software (power class)	18	
Connecting I/O Port(s)	Please refer to the User's Manual	



Note:

- 1 For a more detailed features description, please refer to the manufacturer's specifications or the User's Manual.

2

RF Channel and Frequency of Wi-Fi 802.11 b/g/n			
802.11b/g/n (HT20)		802.11n (HT40)	
RF Channel	Freq.(MHz)	RF Channel	Freq.(MHz)
01	2412	03	2422
02	2417	04	2427
03	2422	05	2432
04	2427	06	2437
05	2432	07	2442
06	2437	08	2447
07	2442	09	2452
08	2447	/	/
09	2452	/	/
10	2457	/	/
11	2462	/	/

3 Note:

- 1) In section 15.31(m), regards to the operating frequency range over 10 MHz, the Lowest frequency, the middle frequency, and the highest frequency of channel were selected to perform the test;
- 2) Test frequencies are lowest channel: 2412 MHz, middle channel: 2437 MHz and highest channel: 2462 MHz for 802.11b/g/n(HT20)
- 3) Test frequencies are lowest channel: 2422 MHz, middle channel: 2437 MHz and highest channel: 2452 MHz for 802.11n(HT40)

4

Ant	Brand	Model Name	Antenna Type	Connector	Gain (dBi)	NOTE
1	N/A	C225(C525)	Integral Antenna	N/A	0	WLAN Antenna



2.2 DESCRIPTION OF TEST MODES

Each of these EUT operation mode(s) or test configuration mode(s) mentioned above was evaluated respectively.

Worst Mode	Description	Data Rate
Mode 1	TX IEEE 802.11b CH1	1 Mbps
Mode 2	TX IEEE 802.11b CH6	1 Mbps
Mode 3	TX IEEE 802.11 b CH11	1 Mbps
Mode 4	TX IEEE 802.11g CH1	6 Mbps
Mode 5	TX IEEE 802.11g CH6	6 Mbps
Mode 6	TX IEEE 802.11g CH11	6 Mbps
Mode 7	TX IEEE 802.11n HT20 CH1	MCS 0
Mode 8	TX IEEE 802.11n HT20 CH6	MCS 0
Mode 9	TX IEEE 802.11n HT20 CH11	MCS 0
Mode 10	TX IEEE 802.11n HT40 CH3	MCS 0
Mode 11	TX IEEE 802.11n HT40 CH6	MCS 0
Mode 12	TX IEEE 802.11n HT40 CH9	MCS 0
Mode13	Wi-Fi transmitting mode	/
Mode 14	Charging mode+SD	/

Note:

- 1) The measurements are performed at all Bit Rate of Transmitter, the worst data was reported
- 2) We have be tested for all avaiable U.S. voltage and frequencies(For 120V,50/60Hz and 240V, 50/60Hz) for which the device is capable of operation, and the worst case of 120V/60Hz is shown in the report
- 3) Controlled using a bespoke application on the laptop PC supplied by the customer. The application was used to enable a continuous transmission mode and to select the test channels, data rates and modulation schemes as required.

2.3 BLOCK DIGRAM SHOWING THE CONFIGURATION OF SYSTEM TESTED

Radiation Test Set

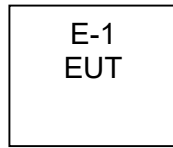

Conduction Test Set

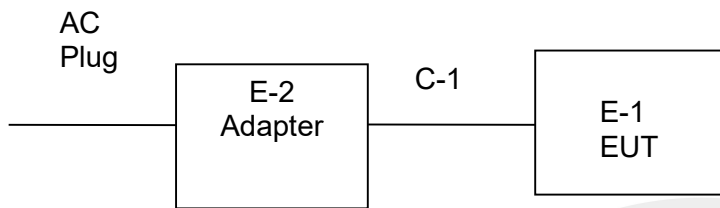

2.4 DESCRIPTION OF SUPPORT UNITS

The EUT has been tested as an independent unit together with other necessary accessories or support units. The following support units or accessories were used to form a representative test configuration during the tests.

Item	Equipment	Mfr/Brand	Model/Type No.	Serial No.	Note
E-2	Adapter	TianYin	TPA-97050150U01	201802001	N/A

Item	Shielded Type	Ferrite Core	Length	Note
C-1	Adapter DC Cable	NO	200cm	N/A

Note:

- 1) The support equipment was authorized by Declaration of Confirmation.
- 2) For detachable type I/O cable should be specified the length in cm in 『Length』 column.
- 3) “YES” is means “shielded” “with core”; “NO” is means “unshielded” “without core”.



2.5 EQUIPMENTS LIST FOR ALL TEST ITEMS

Radiation Test Equipment

Kind of Equipment	Manufacturer	Type No.	Serial No.	Last Calibration	Calibrated Until
EMI Test Receiver	R&S	ESW	101535	2018.05.17	2019.05.16
Bilog Antenna	TESEQ	CBL6111D	34678	2017.11.02	2018.11.01
Horn Antenna	Schwarzbeck	BBHA 9120D	9120D-1343	2017.10.27	2018.10.26
SHF-EHF Horn Antenna (18G-40GHz)	A-INFO	LB-180400-KF	N/A	2018.03.11	2019.03.10
Temperature & Humidity	HH660	Mieo	N/A	2017.10.15	2018.10.14
Temperature & Humidity	HH660	Mieo	N/A	2017.10.15	2018.10.14
Pre-mpifier (0.1M-3GHz)	EM	EM330	60538	2018.03.11	2019.03.10
PreAmplifier (1G-26.5GHz)	Agilent	8449B	60538	2017.10.15	2018.10.14
Passive Loop (9K--30MHz)	ZHNAN	ZN3090C	16035	2018.03.11	2019.03.10
Low frequency cable	EM	R01	N/A	2018.03.11	2019.03.10
Low frequency cable	EM	R06	N/A	2018.03.11	2019.03.10
High frequency cable	SCHWARZBECK	R04	N/A	2018.03.11	2019.03.10
High frequency cable	SCHWARZBECK	R02	N/A	2018.03.11	2019.03.10
Semi-anechoic chamber	Changling	966	N/A	2017.10.15	2018.10.14
trun table	EM	SC100_1	60531	N/A	N/A
Antnna mast	EM	SC100	N/A	N/A	N/A
Max-full Antenna Corp	MF	MFA-440H	N/A	N/A	N/A

Conduction Test Equipment

Kind of Equipment	Manufacturer	Type No.	Serial No.	Last Calibration	Calibrated Until
Test Receiver	R&S	ESCI	101427	2017.10.15	2018.10.14
LISN	R&S	ENV216	101242	2017.10.15	2018.10.14
conduction Cable	EM	C01	N/A	2018.03.11	2019.03.10
Temperature & Humidity	Mieo	HH660	N/A	2017.10.15	2018.10.14



RF Connected Test

Kind of Equipment	Manufacturer	Type No.	Serial No.	Last Calibration	Calibrated Until
USB RF power sensor	DARE	RPR3006W	15I00041SNO03	2017.10.15	2018.10.14
Power Meter	R&S	NRP	100510	2017.10.15	2018.10.14
Spectrum Analyzer	Agilent	N9020A	MY51110105	2018.03.08	2019.03.07
Signal Analyzer	Agilent	N9020A	MY49100060	2017.10.15	2018.10.14

Note:

The temporary antenna connector is soldered on the PCB board in order to perform conducted tests and this temporary antenna connector is listed in the equipment list.





3 EMC EMISSION TEST

3.1 CONDUCTED EMISSION MEASUREMENT

3.1.1 POWER LINE CONDUCTED EMISSION LIMITS

operating frequency band. In case the emission fall within the restricted band specified on Part 15. 207(a), 107(a), RSS-Gen Table3 and ICES-003 Table2 limit in the table below has to be followed. This item was performed according to the procedures in ANSI C63.10: 2013 and ANSI C63.4: 2014.

FREQUENCY (MHz)	Conducted Emission limit (dBuV)	
	Quasi-peak	Average
0.15 -0.5	66 - 56 *	56 - 46 *
0.50 -5.0	56.00	46.00
5.0 -30.0	60.00	50.00

Note:

- 1) The tighter limit applies at the band edges.
- 2) The limit of " * " marked band means the limitation decreases linearly with the logarithm of the frequency in the range.

The following table is the setting of the receiver

Receiver Parameters	Setting
Attenuation	10 dB
Start Frequency	0.15 MHz
Stop Frequency	30 MHz
IF Bandwidth	9 kHz

3.1.2 TEST PROCEDURE

- a. The EUT was 0.8 meters from the horizontal ground plane and 0.4 meters from the vertical ground plane with EUT being connected to the power mains through a line impedance stabilization network (LISN). All other support equipments powered from additional LISN(s). The LISN provide 50 Ohm/ 50uH of coupling impedance for the measuring instrument.
- b. Interconnecting cables that hang closer than 40 cm to the ground plane shall be folded back and forth in the center forming a bundle 30 to 40 cm long.
- c. I/O cables that are not connected to a peripheral shall be bundled in the center. The end of the cable may be terminated, if required, using the correct terminating impedance. The overall length shall not exceed 1 m.
- d. LISN at least 80 cm from nearest part of EUT chassis.
- e. For the actual test configuration, please refer to the related Item –EUT Test Photos.

3.1.3 TEST SETUP

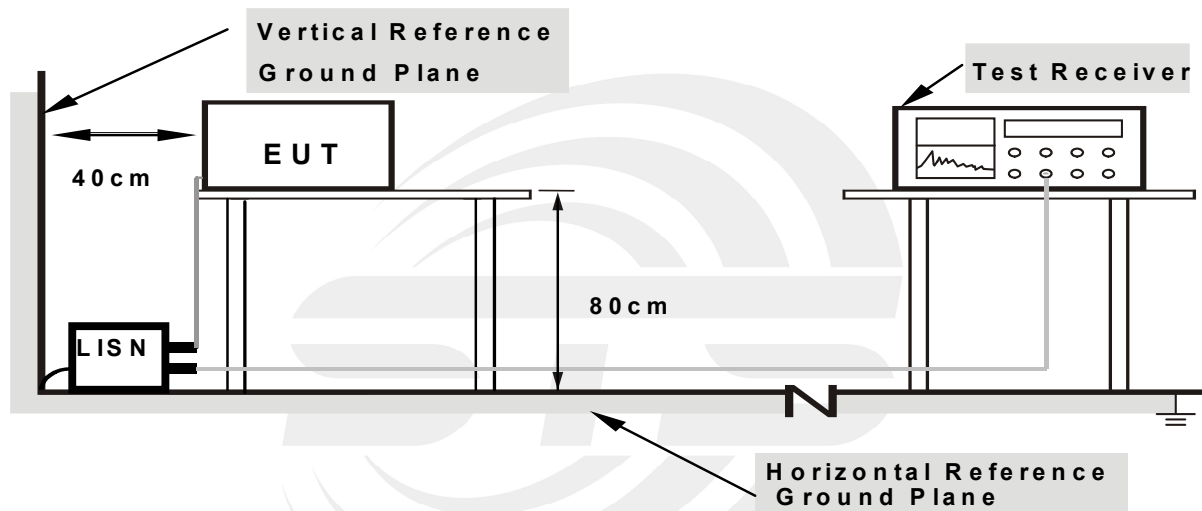

Note: 1. Support units were connected to second LISN.

2. Both of LISNs (AMN) are 80 cm from EUT and at least 80 cm from other units and other metal planes

3.1.4 EUT OPERATING CONDITIONS

The EUT was configured for testing in a typical fashion (as a customer would normally use it). The EUT has been programmed to continuously transmit during test. This operating condition was tested and used to collect the included data.



3.1.5 TEST RESULT

Temperature:	25 °C	Relative Humidity:	61%
Test Voltage:	AC 120V/60Hz	Phase:	L
Test Mode:	Mode 13		

Frequency (MHz)	Reading (dBUV)	Correct Factor(dB)	Result (dBUV)	Limit (dBUV)	Margin (dB)	Remark
0.1660	38.15	9.79	47.94	65.16	-17.22	QP
0.1660	20.87	9.79	30.66	55.16	-24.50	AVG
0.3020	32.44	10.23	42.67	60.19	-17.52	QP
0.4100	17.65	10.03	27.68	47.65	-19.97	AVG
0.6100	35.02	9.93	44.95	56.00	-11.05	QP
0.6100	26.05	9.93	35.98	46.00	-10.02	AVG
0.8460	17.62	9.83	27.45	46.00	-18.55	QP
1.1500	29.52	9.80	39.32	56.00	-16.68	AVG
3.6980	28.06	9.82	37.88	56.00	-18.12	QP
4.9900	13.08	9.85	22.93	46.00	-23.07	AVG
18.0420	26.82	10.38	37.20	60.00	-22.80	QP
18.0420	16.56	10.38	26.94	50.00	-23.06	AVG

Remark:

1. All readings are Quasi-Peak and Average values.
2. Margin = Result (Result = Reading + Factor) – Limit

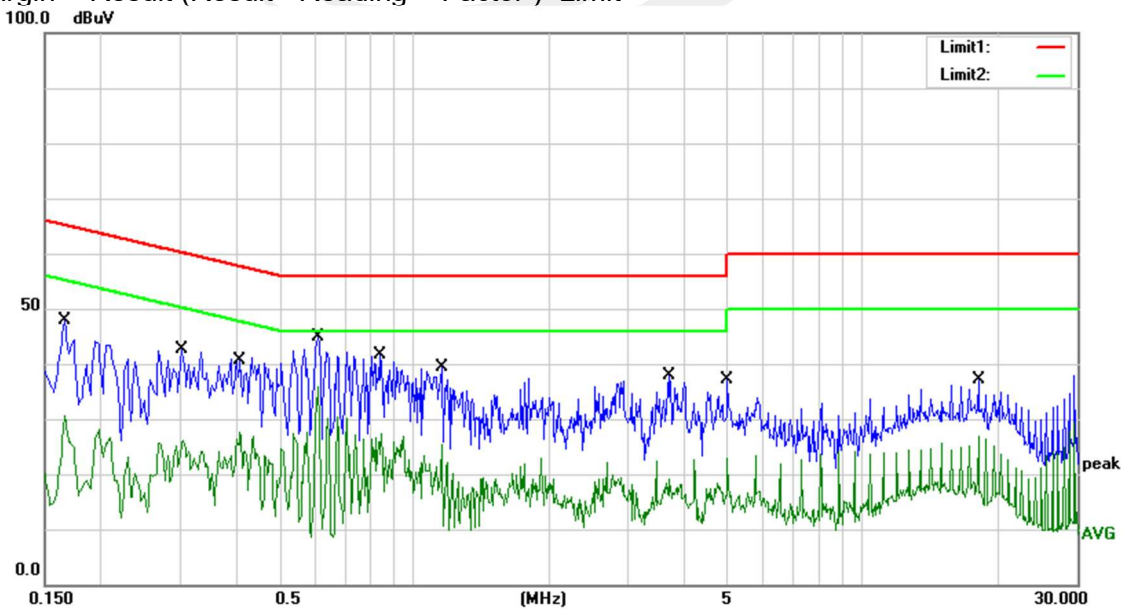



Temperature:	25 °C	Relative Humidity:	61%
Test Voltage:	AC 120V/60Hz	Phase:	N
Test Mode:	Mode 13		

Frequency (MHz)	Reading (dBuV)	Correct Factor(dB)	Result (dBuV)	Limit (dBuV)	Margin (dB)	Remark
0.2020	35.88	9.88	45.76	63.53	-17.77	QP
0.2100	16.78	9.91	26.69	53.21	-26.52	AVG
0.6020	36.08	9.92	46.00	56.00	-10.00	QP
0.6020	26.05	9.92	35.97	46.00	-10.03	AVG
0.8420	18.11	9.84	27.95	46.00	-18.05	QP
0.9380	29.04	9.81	38.85	56.00	-17.15	AVG
2.6860	15.91	9.90	25.81	46.00	-20.19	QP
2.7900	26.49	9.90	36.39	56.00	-19.61	AVG
8.0620	25.94	9.90	35.84	60.00	-24.16	QP
11.9020	16.14	9.98	26.12	50.00	-23.88	AVG
29.5620	31.26	10.51	41.77	60.00	-18.23	QP
29.5620	17.33	10.51	27.84	50.00	-22.16	AVG

Remark:

1. All readings are Quasi-Peak and Average values.
2. Margin = Result (Result = Reading + Factor) - Limit

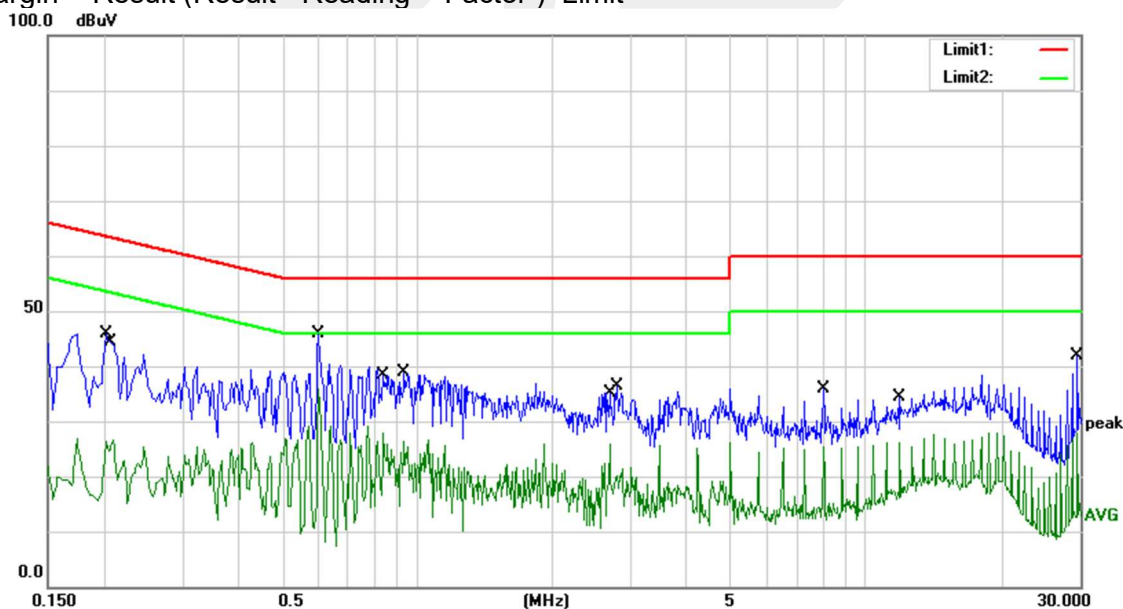



Temperature:	25 °C	Relative Humidity:	61%
Test Voltage:	AC 120V/60Hz	Phase:	N
Test Mode:	Mode 14 (Part 15B & ICES-003)		

Frequency (MHz)	Reading (dBUV)	Correct Factor(dB)	Result (dBUV)	Limit (dBUV)	Margin (dB)	Remark
0.1500	40.49	9.75	50.24	66.00	-15.76	QP
0.1780	19.30	9.82	29.12	54.58	-25.46	AVG
0.6020	35.99	9.92	45.91	56.00	-10.09	QP
0.6060	24.57	9.92	34.49	46.00	-11.51	AVG
0.9220	29.41	9.82	39.23	56.00	-16.77	QP
1.1500	18.75	9.81	28.56	46.00	-17.44	AVG
2.6860	27.31	9.90	37.21	56.00	-18.79	QP
3.4540	15.15	9.92	25.07	46.00	-20.93	AVG
14.2060	27.46	10.05	37.51	60.00	-22.49	QP
14.2060	17.14	10.05	27.19	50.00	-22.81	AVG
29.5620	31.11	10.51	41.62	60.00	-18.38	QP
29.5620	17.33	10.51	27.84	50.00	-22.16	AVG

Remark:

1. All readings are Quasi-Peak and Average values.
2. Margin = Result (Result = Reading + Factor) – Limit

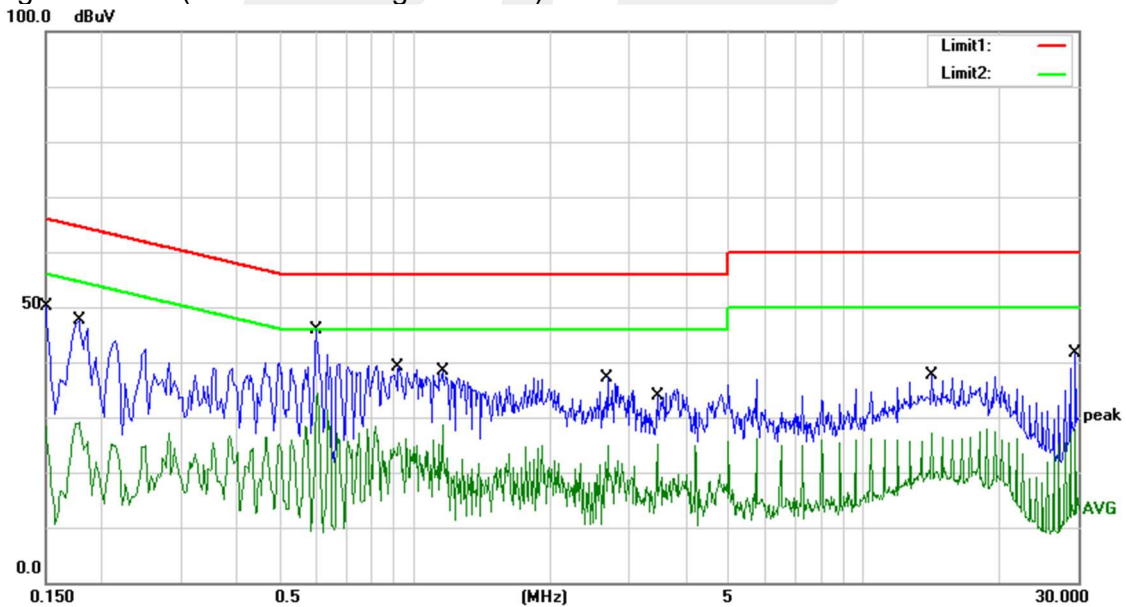



Temperature:	25 °C	Relative Humidity:	61%
Test Voltage:	AC 120V/60Hz	Phase:	L
Test Mode:	Mode 14 (Part 15B & ICES-003)		

Frequency (MHz)	Reading (dBUV)	Correct Factor(dB)	Result (dBUV)	Limit (dBUV)	Margin (dB)	Remark
0.1780	37.72	9.78	47.50	64.58	-17.08	QP
0.1780	20.65	9.78	30.43	54.58	-24.15	AVG
0.6060	23.96	9.93	33.89	46.00	-12.11	QP
0.6100	38.65	9.93	48.58	56.00	-7.42	AVG
1.7580	28.00	9.78	37.78	56.00	-18.22	QP
1.7580	12.95	9.78	22.73	46.00	-23.27	AVG
3.6580	26.31	9.82	36.13	56.00	-19.87	QP
4.9900	14.61	9.85	24.46	46.00	-21.54	AVG
18.0420	16.49	10.38	26.87	50.00	-23.13	QP
20.3460	26.69	10.44	37.13	60.00	-22.87	AVG
29.5620	27.12	10.28	37.40	60.00	-22.60	QP
29.5620	18.53	10.28	28.81	50.00	-21.19	AVG

Remark:

1. All readings are Quasi-Peak and Average values.
2. Margin = Result (Result = Reading + Factor) – Limit

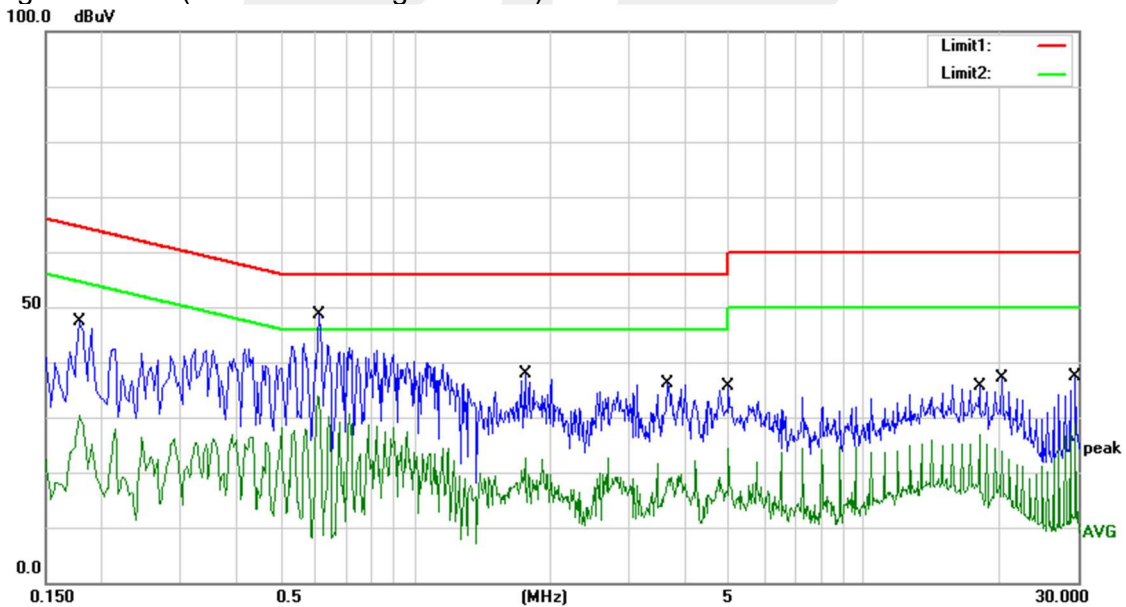



3.2 RADIATED EMISSION MEASUREMENT

3.2.1 RADIATED EMISSION LIMITS

Frequencies (MHz)	Class A (at 10m) dBuV/m	Class B (at 3m) dBuV/m
30~88	39.0	40.0
88~216	43.5	43.5
216~960	46.5	46.0
Above 960	49.5	54.0

LIMITS OF RADIATED EMISSION MEASUREMENT (Above 1000MHz)

FREQUENCY (MHz)	Class A (dBuV/m) (at 3M)		Class B (dBuV/m) (at 3M)	
	PEAK	AVERAGE	PEAK	AVERAGE
Above 1000	80	60	74	54

Note:

- 1) The tighter limit applies at the band edges.
- 2) Emission level (dBuV/m)=20log Emission level (uV/m).

3.2.2 TEST PROCEDURE

- a) The measuring distance of at 3 m shall be used for measurements at frequency up to 1GHz. For frequencies above 1GHz, any suitable measuring distance may be used.
- b) The EUT was placed on the top of a rotating table 0.8 meters above the ground at a 3 meter open area test site. The table was rotated 360 degrees to determine the position of the highest radiation.
- c) The height of the equipment or of the substitution antenna shall be 0.8 m; the height of the test antenna shall vary between 0.8 m to 4 m. Both horizontal and vertical polarizations of the antenna are set to make the measurement.
- d) The initial step in collecting conducted emission data is a spectrum analyzer peak detector mode pre-scanning the measurement frequency range. Significant peaks are then marked and then Quasi Peak detector mode re-measured.
- e) If the Peak Mode measured value compliance with and lower than Quasi Peak Mode Limit, the EUT shall be deemed to meet QP Limits and then no additional QP Mode measurement performed.
- f) For the actual test configuration, please refer to the related Item –EUT Test Photos.

Note: Both horizontal and vertical antenna polarities were tested and performed pretest to three orthogonal axis. The worst case emissions were reported

3.2.3 TEST SETUP

a) Radiated Emission Test-Up Frequency 30MHz~1GHz

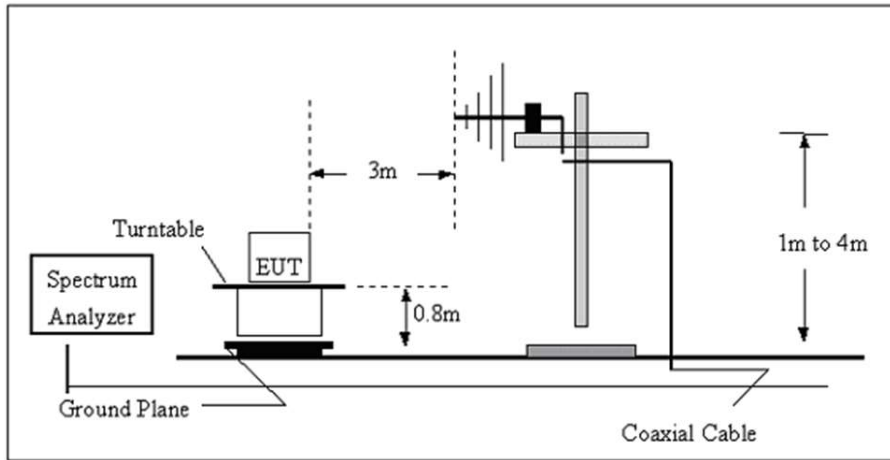

b) Radiated Emission Test-Up Frequency Above 1GHz

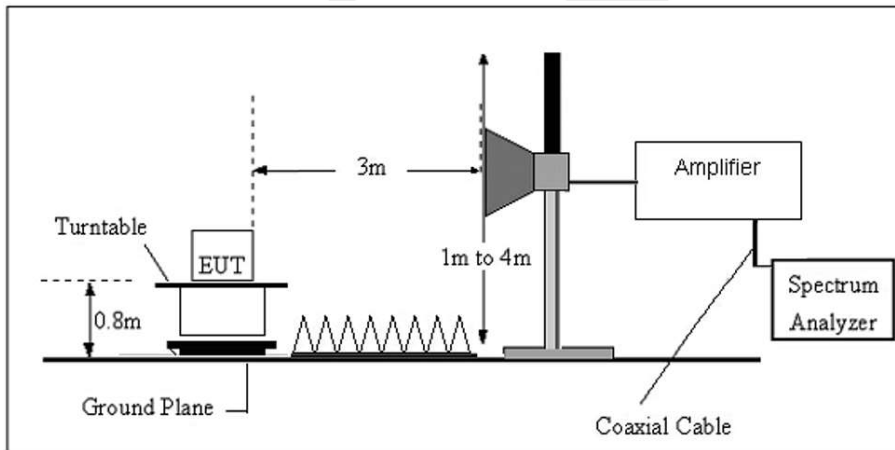

3.2.4 EUT OPERATING CONDITIONS

The EUT tested system was configured as the statements of 2.4 Unless otherwise a special operating condition is specified in the follows during the testing.



3.2.5 TEST RESULTS

Between 30-1000MHz:

Temperature:	26 °C	Relative Humidity:	54%
Pressure:	1010hPa	Phase:	Horizontal
Test Voltage:	AC 120V/60Hz	Test Mode:	Mode 14 (Part 15B & ICES-003)

No.	Frequency (MHz)	Reading (dBuV)	Factor (dB)	Results (dBuV/m)	Limit (dBuV/m)	Margin (dB)	Detector
1	114.9170	55.08	-18.02	37.06	43.50	-6.44	QP
2	337.2155	48.46	-14.04	34.42	46.00	-11.58	QP
3	487.3151	42.34	-9.21	33.13	46.00	-12.87	QP
4	562.6624	41.82	-6.57	35.25	46.00	-10.75	QP
5	714.1734	41.85	-4.84	37.01	46.00	-8.99	QP
6	787.8513	37.20	-3.24	33.96	46.00	-12.04	QP

Remark:

1. All readings are Quasi-Peak .
2. Margin = Result (Result =Reading + Factor)-Limit





Temperature:	26 °C	Relative Humidity:	54%
Pressure:	1010hPa	Phase:	Vertical
Test Voltage:	AC 120V/60Hz	Test Mode:	Mode 14 (Part 15B & ICES-003)

No.	Frequency (MHz)	Reading (dBuV)	Factor (dB)	Results (dBuV/m)	Limit (dBuV/m)	Margin (dB)	Detector
1	37.9846	52.36	-15.28	37.08	40.00	-2.92	QP
2	115.7256	52.33	-17.97	34.36	43.50	-9.14	QP
3	210.7860	50.80	-19.69	31.11	43.50	-12.39	QP
4	562.6624	46.19	-6.57	39.62	46.00	-6.38	QP
5	714.1734	47.43	-4.84	42.59	46.00	-3.41	QP
6	787.8513	42.72	-3.24	39.48	46.00	-6.52	QP

Remark:

1. All readings are Quasi-Peak .
2. Margin = Result (Result =Reading + Factor)-Limit





Between 1GHz – 6GHz:



德普华检测中心 Shenzhen STS Test Services Co., Ltd.
 Zhuoke Science Park, Chongqing Road, Fuyong, Baoan District, Shenzhen, China
 Tel: (86)-0755-36886288 FAX: (86)-0755-36886277 http://www.stsapp.com

Test result

Project Number: STS1806066

Test Time: 2018-06-13_12.39.01

EUT Name: Baby Monitor

Test Engineer: Zhou GL

Model: B225(B220)

Test Standard: FCC Part15B

Model: Charging mode+SD

Work Addition: Normal

Temp.(oC): 25

Ant.Polar.: Horizontal

Hum.: 65%

Remark: N.A

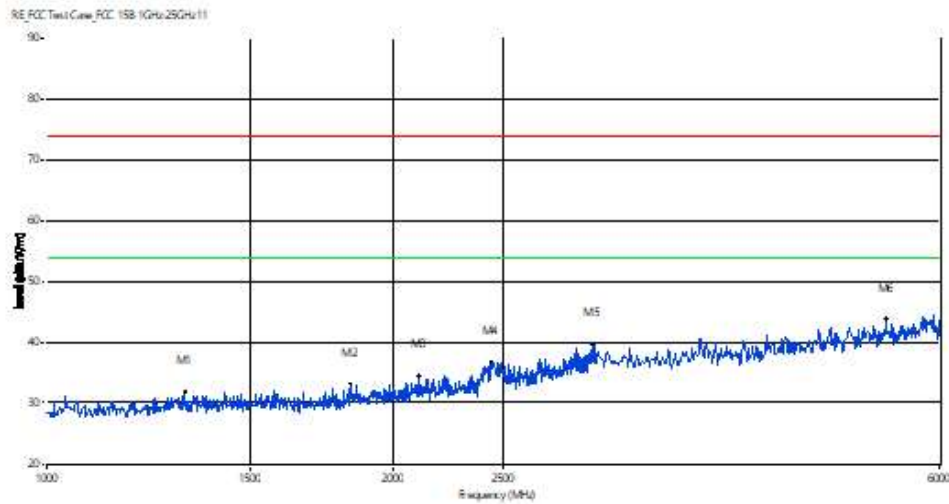

No.	Frequency (MHz)	Results (dBuV/m)	Factor (dB)	Limit (dBuV/m)	Margin (dB)	Detector	Table (o)	Height (cm)	ANT	Verdict
1	1317.882	31.90	-19.59	74.00	-42.10	Peak	219.80	100	Horizontal	Pass
1	1317.882	21.25	-19.59	54.00	-32.75	Avg	219.80	100	Horizontal	Pass
2	1837.163	33.15	-18.29	74.00	-40.85	Peak	11.10	100	Horizontal	Pass
2	1837.163	23.47	-18.29	54.00	-30.53	Avg	11.10	100	Horizontal	Pass
3	2106.893	34.50	-17.14	74.00	-39.50	Peak	243.20	100	Horizontal	Pass
3	2106.893	23.88	-17.14	54.00	-30.12	Avg	243.20	100	Horizontal	Pass
4	2438.561	36.81	-13.86	74.00	-37.19	Peak	202.70	100	Horizontal	Pass
4	2438.561	27.62	-13.86	54.00	-26.38	Avg	202.70	100	Horizontal	Pass
5	2986.014	39.63	-12.27	74.00	-34.37	Peak	266.30	100	Horizontal	Pass
5	2986.014	29.97	-12.27	54.00	-24.03	Avg	266.30	100	Horizontal	Pass
6	5387.612	43.92	-6.27	74.00	-30.08	Peak	128.70	100	Horizontal	Pass
6	5387.612	33.41	-6.27	54.00	-20.59	Avg	128.70	100	Horizontal	Pass



德普华检测中心 Shenzhen STS Test Services Co., Ltd.
Zhuoke Science Park, Chongqing Road, Fuyong, Baoan District, Shenzhen, China
Tel: (86)-0755-36886288 FAX: (86)-0755-36886277 http://www.stsapp.com

Test result

Project Number: STS1806066

Test Time: 2018-06-13_12.36.06

EUT Name: Baby Monitor

Model: B225 (B220)

Model: Charging mode+SD

Temp.(oC): 25

Hum.: 65%

Test Engineer: Zhou GL

Test Standard: FCC Part15B

Work Addition: Normal

Ant.Polar.: Vertical

Remark: N.A

RE_FCC_Test Case_FCC_15B_1GHz-250Hz/11

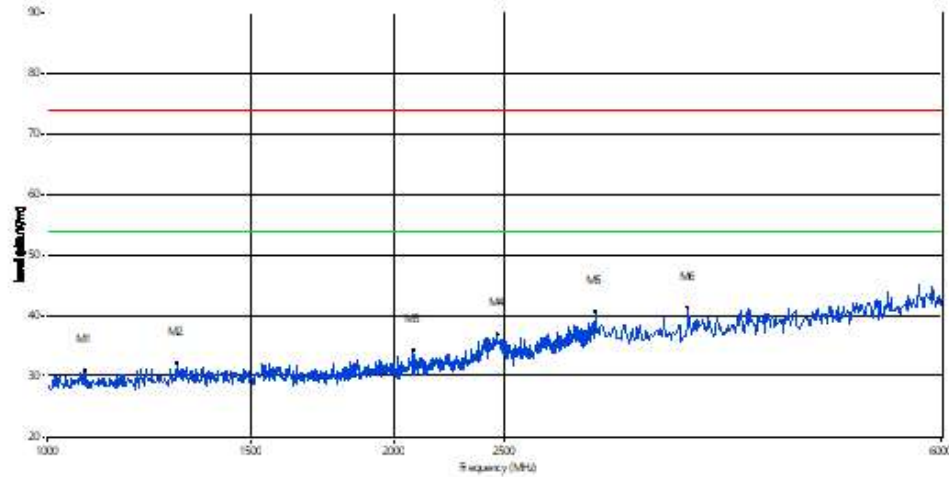

Table with 11 columns: No., Frequency (MHz), Results (dBuV/m), Factor (dB), Limit (dBuV/m), Margin (dB), Detector, Table (o), Height (cm), ANT, Verdict. It contains 18 rows of test data.



3.3 RADIATED SPURIOUS EMISSION MEASUREMENT

3.3.1 RADIATED EMISSION LIMITS

in any 100 kHz bandwidth outside the operating frequency band. In case the emission fall within the Restricted band specified on Part15.205(a)&209(a) and RSS-247 Issue 2 limit in the table and according to ANSI C63.10-2013 below has to be followed.

LIMITS OF RADIATED EMISSION MEASUREMENT (0.009MHz - 1000MHz)

Frequencies (MHz)	Field Strength (micorvolts/meter)	Measurement Distance (meters)
0.009~0.490	2400/F(KHz)	300
0.490~1.705	24000/F(KHz)	30
1.705~30.0	30	30
30~88	100	3
88~216	150	3
216~960	200	3
Above 960	500	3

LIMITS OF RADIATED EMISSION MEASUREMENT (1000MHz-25GHz)

FREQUENCY (MHz)	(dBuV/m) (at 3M)	
	PEAK	AVERAGE
Above 1000	74	54

Notes:

- (1) The limit for radiated test was performed according to FCC PART 15C.
- (2) The tighter limit applies at the band edges.
- (3) Emission level (dBuV/m)=20log Emission level (uV/m).

For Radiated Emission

Spectrum Parameter	Setting
Attenuation	Auto
Detector	Peak/AV
Start Frequency	1000 MHz(Peak/AV)
Stop Frequency	10th carrier hamonic(Peak/AV)
RB / VB (emission in restricted band)	1 MHz /3MHz

For Band edge

Spectrum Parameter	Setting
Detector	Peak/AV
Start/Stop Frequency	Lower Band Edge: 2300 to 2422 MHz Upper Band Edge: 2452 to 2500 MHz
RB / VB (emission in restricted band)	1 MHz /3MHz



Receiver Parameter	Setting
Start ~ Stop Frequency	9kHz~90kHz / RB 200Hz for PK & AV
Start ~ Stop Frequency	90kHz~110kHz / RB 200Hz for QP
Start ~ Stop Frequency	110kHz~490kHz / RB 200Hz for PK & AV
Start ~ Stop Frequency	490kHz~30MHz / RB 9kHz for QP
Start ~ Stop Frequency	30MHz~1000MHz / RB 120kHz for QP

3.3.2 TEST PROCEDURE

- a) The measuring distance of at 3 m shall be used for measurements at frequency 0.009MHz up to 1GHz. For frequencies above 1GHz, any suitable measuring distance may be used.
- b) The EUT was placed on the top of a rotating table 0.8 meters(above 1GHz is 1.5 m) above the ground at a 3 meter anechoic chamber. The table was rotated 360 degrees to determine the position of the highest radiation.
- c) The height of the equipment shall be 0.8 m(above 1GHz is 1.5 m); the height of the test antenna shall vary between 1 m to 4 m. Horizontal and vertical polarizations of the antenna are set to make the measurement
- d) The initial step in collecting conducted emission data is a spectrum analyzer peak detector mode pre-scanning the measurement frequency range. Significant peaks are then marked and then Quasi Peak detector mode re-measured.
- e) If the Peak Mode measured value compliance with and lower than Quasi Peak Mode Limit, the EUT shall be deemed to meet QP Limits and then no additional QP Mode measurement performed.
- f) For the actual test configuration, please refer to the related Item –EUT Test Photos.

Note:

Both horizontal and vertical antenna polarities were tested and performed test to three orthogonal axis. The worst case emissions were reported

3.3.3 TEST SETUP

a) Radiated Emission Test-Up Frequency Below 30MHz

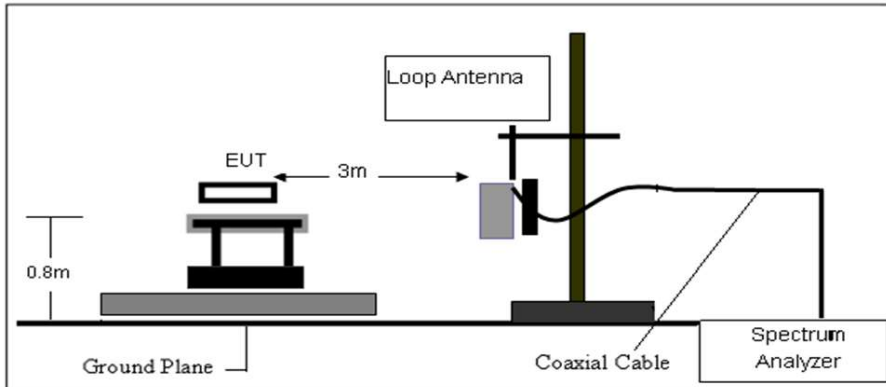

b) Radiated Emission Test-Up Frequency 30MHz~1GHz

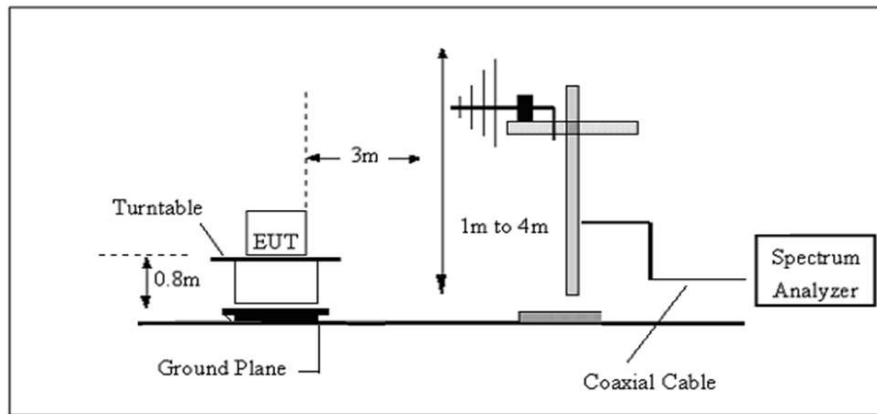

c) Radiated Emission Test-Up Frequency Above 1GHz

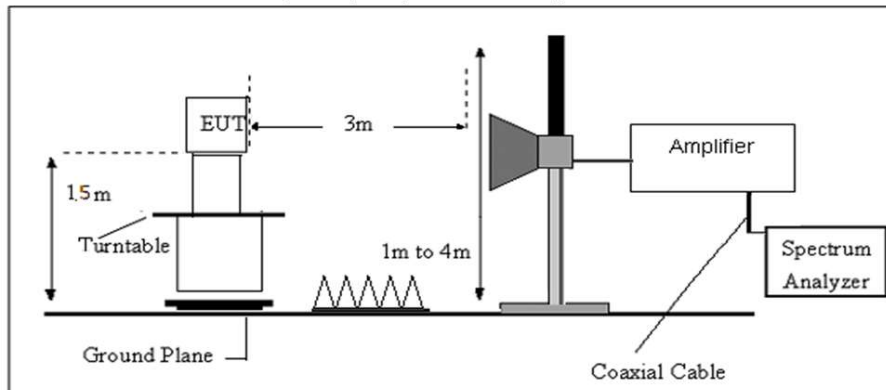

3.3.4 EUT OPERATING CONDITIONS

The EUT tested system was configured as the statements of 2.3 Unless otherwise a special operating condition is specified in the follows during the testing.



3.3.5 FIELD STRENGTH CALCULATION

The field strength is calculated by adding the Antenna Factor and Cable Factor and subtracting the Amplifier Gain and Duty Cycle Correction Factor (if any) from the measured reading. The basic equation with a sample calculation is as follows:

$$FS = RA + AF + CL - AG$$

Where

FS = Field Strength

CL = Cable Attenuation Factor (Cable Loss)

RA = Reading Amplitude

AG = Amplifier Gain

AF = Antenna Factor

For example

Frequency	FS	RA	AF	CL	AG	Factor
(MHz)	(dBμV/m)	(dBμV/m)	(dB)	(dB)	(dB)	(dB)
300	40	58.1	12.2	1.6	31.9	-18.1

$$\text{Factor} = \text{AF} + \text{CL} - \text{AG}$$

3.3.6 TEST RESULT

9KHz-30MHz

Temperature:	25 °C	Relative Humidity:	61%
Test Voltage :	DC 3.8V From Battery	Polarization :	--
Test Mode :	TX Mode		

Freq.	Reading	Limit	Margin	State	Test Result
(MHz)	(dBuV/m)	(dBuV/m)	(dB)	P/F	
--	--	--	--	--	PASS
--	--	--	--	--	PASS

Note:

The amplitude of spurious emissions which are attenuated by more than 20dB below the permissible value has no need to be reported.

Distance extrapolation factor = $40 \log (\text{specific distance}/\text{test distance})$ (dB);

Limit line = specific limits(dBuV) + distance extrapolation factor.



(30MHz - 1000MHz)

Temperature:	25.7 °C	Relative Humidity:	63%
Test Voltage :	DC 3.8V	Polarization :	Horizontal
Test Mode :	Mode 1/2/3/4/5/6/7/8/9/10/11/12(Mode 2-1Mbps worst mode)		

Frequency (MHz)	Reading (dBuV)	Correct Factor(dB/m)	Result (dBuV/m)	Limit (dBuV/m)	Margin (dB)	Remark
124.1330	35.97	-17.64	18.33	43.50	-25.17	QP
562.6624	35.61	-6.57	29.04	46.00	-16.96	QP
638.3686	36.03	-6.36	29.67	46.00	-16.33	QP
714.1734	40.28	-4.84	35.44	46.00	-10.56	QP
787.8513	38.23	-3.24	34.99	46.00	-11.01	QP
900.1474	42.42	-2.26	40.16	46.00	-5.84	QP

Remark:

1. Margin = Result (Result =Reading + Factor)–Limit

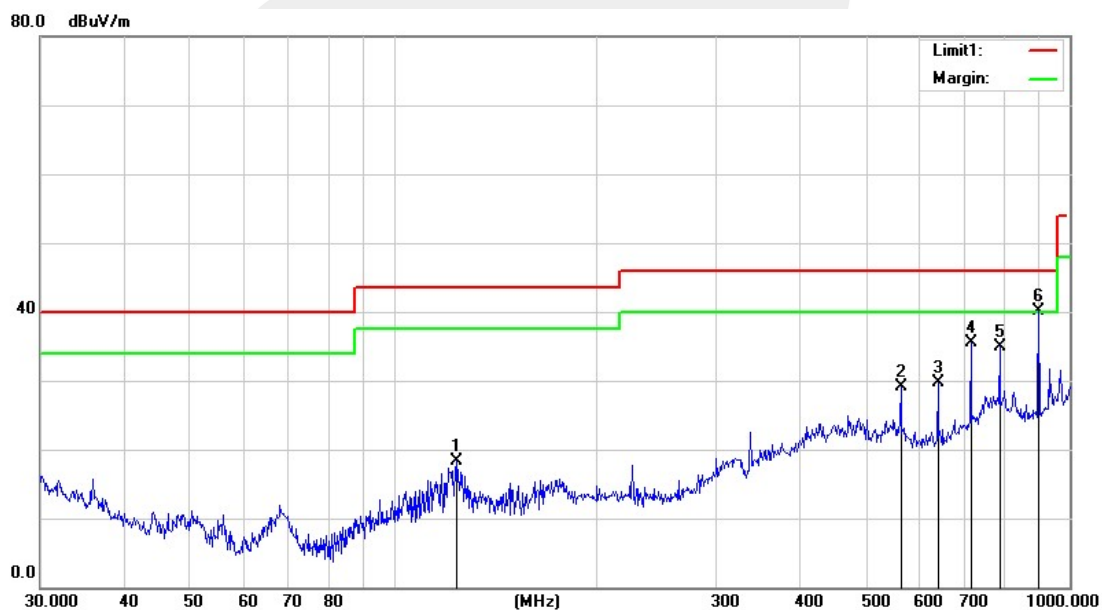



Temperature:	25.7 °C	Relative Humidity:	63%
Test Voltage :	DC 3.8V	Polarization :	Vertical
Test Mode :	Mode 1/2/3/4/5/6/7/8/9/10/11/12(Mode 2-1Mbps worst mode)		

Frequency (MHz)	Reading (dBuV)	Correct Factor(dB/m)	Result (dBuV/m)	Limit (dBuV/m)	Margin (dB)	Remark
124.1330	37.29	-17.64	19.65	43.50	-23.85	QP
181.9202	35.26	-19.60	15.66	43.50	-27.84	QP
487.3151	49.89	-9.21	40.68	46.00	-5.32	QP
562.6624	48.96	-6.57	42.39	46.00	-3.61	QP
714.1734	42.37	-4.84	37.53	46.00	-8.47	QP
787.8513	37.94	-3.24	34.70	46.00	-11.30	QP

Remark:.

1. Margin = Result (Result =Reading + Factor)–Limit

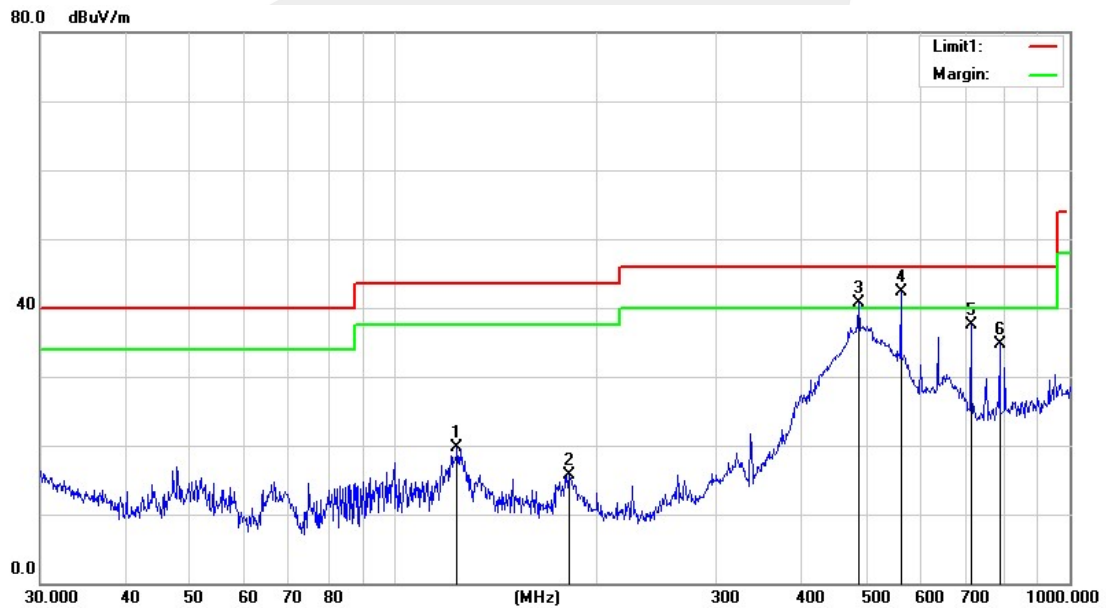



(1000MHz-25GHz) Restricted band and Spurious emission Requirements

802.11b Low Channel

Frequency (MHz)	Results (dBuV/m)	Factor (dB)	Limit (dBuV/m)	Margin (dB)	Detector	ANT	Verdict
24904.096	62.34	7.07	74.00	-11.66	Peak	Vertical	Pass
24904.096	49.11	7.07	54.00	-4.89	Average	Vertical	Pass
16980.020	59.03	7.09	74.00	-14.97	Peak	Vertical	Pass
16980.020	46.45	7.09	54.00	-7.55	Average	Vertical	Pass
13299.700	56.09	2.15	74.00	-17.91	Peak	Vertical	Pass
13299.700	44.28	2.15	54.00	-9.72	Average	Vertical	Pass
9503.497	53.28	2.61	74.00	-20.72	Peak	Vertical	Pass
9503.497	42.04	2.61	54.00	-11.96	Average	Vertical	Pass
6796.204	47.77	-4.07	74.00	-26.23	Peak	Vertical	Pass
6796.204	35.96	-4.07	54.00	-18.04	Average	Vertical	Pass
2998.002	41.82	-11.24	74.00	-32.18	Peak	Vertical	Pass
2998.002	30.77	-11.24	54.00	-23.23	Average	Vertical	Pass
24940.060	62.46	7.09	74.00	-11.54	Peak	Horizontal	Pass
24940.060	49.17	7.09	54.00	-4.83	Average	Horizontal	Pass
16296.703	58.92	6.58	74.00	-15.08	Peak	Horizontal	Pass
16296.703	47.58	6.58	54.00	-6.42	Average	Horizontal	Pass
14102.897	57.13	4.01	74.00	-16.87	Peak	Horizontal	Pass
14102.897	44.39	4.01	54.00	-9.61	Average	Horizontal	Pass
9493.506	52.89	1.16	74.00	-21.11	Peak	Horizontal	Pass
9493.506	41.66	1.16	54.00	-12.34	Average	Horizontal	Pass
6806.194	48.96	-3.99	74.00	-25.04	Peak	Horizontal	Pass
6806.194	37.58	-3.99	54.00	-16.42	Average	Horizontal	Pass
2996.004	42.41	-11.4	74.00	-31.59	Peak	Horizontal	Pass
2996.004	31.17	-11.4	54.00	-22.83	Average	Horizontal	Pass

**802.11b Mid Channel**

Frequency (MHz)	Results (dBuV/m)	Factor (dB)	Limit (dBuV/m)	Margin (dB)	Detector	ANT	Verdict
24292.707	62.91	6.77	74.00	-11.09	Peak	Vertical	Pass
24292.707	49.35	6.77	54.00	-4.65	Average	Vertical	Pass
16164.835	59.59	6.07	74.00	-14.41	Peak	Vertical	Pass
16164.835	47.08	6.07	54.00	-6.92	Average	Vertical	Pass
14102.897	57.18	4.01	74.00	-16.82	Peak	Vertical	Pass
14102.897	45.24	4.01	54.00	-8.76	Average	Vertical	Pass
9533.467	52.02	0.76	74.00	-21.98	Peak	Vertical	Pass
9533.467	40.12	0.76	54.00	-13.88	Average	Vertical	Pass
6816.184	49.87	-3.86	74.00	-24.13	Peak	Vertical	Pass
6816.184	37.48	-3.86	54.00	-16.52	Average	Vertical	Pass
2990.010	42.66	-11.87	74.00	-31.34	Peak	Vertical	Pass
2990.010	31.05	-11.87	54.00	-22.95	Average	Vertical	Pass
22950.050	62.64	6.52	74.00	-11.36	Peak	Horizontal	Pass
22950.050	49.77	6.52	54.00	-4.23	Average	Horizontal	Pass
16344.655	58.71	5.70	74.00	-15.29	Peak	Horizontal	Pass
16344.655	46.11	5.70	54.00	-7.89	Average	Horizontal	Pass
14090.909	56.56	3.41	74.00	-17.44	Peak	Horizontal	Pass
14090.909	44.62	3.41	54.00	-9.38	Average	Horizontal	Pass
9503.497	52.19	2.61	74.00	-21.81	Peak	Horizontal	Pass
9503.497	41.02	2.61	54.00	-12.98	Average	Horizontal	Pass
6776.224	49.75	-4.10	74.00	-24.25	Peak	Horizontal	Pass
6776.224	37.23	-4.10	54.00	-16.77	Average	Horizontal	Pass
2996.004	41.85	-11.40	74.00	-32.15	Peak	Horizontal	Pass
2996.004	30.46	-11.40	54.00	-23.54	Average	Horizontal	Pass

**802.11b High Channel**

Frequency (MHz)	Results (dBuV/m)	Factor (dB)	Limit (dBuV/m)	Margin (dB)	Detector	ANT	Verdict
24280.719	62.18	6.76	74.00	-11.82	Peak	Vertical	Pass
24280.719	49.01	6.76	54.00	-4.99	Average	Vertical	Pass
16296.703	59.46	6.58	74.00	-14.54	Peak	Vertical	Pass
16296.703	46.85	6.58	54.00	-7.15	Average	Vertical	Pass
14114.885	56.87	3.96	74.00	-17.13	Peak	Vertical	Pass
14114.885	44.18	3.96	54.00	-9.82	Average	Vertical	Pass
9503.497	52.81	2.61	74.00	-21.19	Peak	Vertical	Pass
9503.497	40.34	2.61	54.00	-13.66	Average	Vertical	Pass
6806.194	49.24	-3.99	74.00	-24.76	Peak	Vertical	Pass
6806.194	36.99	-3.99	54.00	-17.01	Average	Vertical	Pass
2998.002	42.57	-11.24	74.00	-31.43	Peak	Vertical	Pass
2998.002	30.21	-11.24	54.00	-23.79	Average	Vertical	Pass
24784.216	62.18	7.01	74.00	-11.82	Peak	Horizontal	Pass
24784.216	49.36	7.01	54.00	-4.64	Average	Horizontal	Pass
16980.020	59.37	7.09	74.00	-14.63	Peak	Horizontal	Pass
16980.020	46.82	7.09	54.00	-7.18	Average	Horizontal	Pass
14102.897	57.35	4.01	74.00	-16.65	Peak	Horizontal	Pass
14102.897	45.33	4.01	54.00	-8.67	Average	Horizontal	Pass
9503.497	52.68	2.61	74.00	-21.32	Peak	Horizontal	Pass
9503.497	41.42	2.61	54.00	-12.58	Average	Horizontal	Pass
6836.164	49.20	-4.18	74.00	-24.80	Peak	Horizontal	Pass
6836.164	37.44	-4.18	54.00	-16.56	Average	Horizontal	Pass
2988.012	42.62	-12.07	74.00	-31.38	Peak	Horizontal	Pass
2988.012	30.08	-12.07	54.00	-23.92	Average	Horizontal	Pass

Remark:

- Factor = Antenna Factor + Cable Loss – Pre-amplifier.
- Scan with 802.11b, 802.11g, 802.11n (HT-20), 802.11n (HT-40) the worst case is 802.11b.
Emission Level = Reading + Factor
Margin = Limit - Emission Level
- The frequency emission of peak points that did not show above the forms are at least 20dB below the limit, the frequency emission is mainly from the environment noise.



3.3.7 TEST RESULTS (BAND EDGE REQUIREMENTS)

Frequency (MHz)	Reading (dBμV)	Amplifier (dB)	Loss (dB)	Antenna Factor (dB/m)	Corrected Factor (dB)	Emission Level (dBμV/m)	Limits (dBμV/m)	Margin (dB)	Detector Type	Comment
802.11b										
2390.00	68.12	43.80	4.91	25.90	-12.99	55.13	74.00	-18.55	PK	Vertical
2390.00	53.47	43.80	4.91	25.90	-12.99	40.48	54.00	-13.86	AV	Vertical
2390.00	68.24	43.80	4.91	25.90	-12.99	55.25	74.00	-18.30	PK	Horizontal
2390.00	53.03	43.80	4.91	25.90	-12.99	40.04	54.00	-13.76	AV	Horizontal
2483.50	68.75	43.80	5.12	25.90	-12.78	55.97	74.00	-16.43	PK	Vertical
2483.50	52.69	43.80	5.12	25.90	-12.78	39.91	54.00	-14.48	AV	Vertical
2483.50	69.57	43.80	5.12	25.90	-12.78	56.79	74.00	-17.63	PK	Horizontal
2483.50	53.49	43.80	5.12	25.90	-12.78	40.71	54.00	-13.60	AV	Horizontal
802.11g										
2390.00	67.12	43.80	4.91	25.90	-12.99	54.13	74.00	-19.87	PK	Vertical
2390.00	52.69	43.80	4.91	25.90	-12.99	39.70	54.00	-14.30	AV	Vertical
2390.00	65.24	43.80	4.91	25.90	-12.99	52.25	74.00	-21.75	PK	Horizontal
2390.00	53.07	43.80	4.91	25.90	-12.99	40.08	54.00	-13.92	AV	Horizontal
2483.50	65.67	43.80	5.12	25.90	-12.78	52.89	74.00	-21.11	PK	Vertical
2483.50	53.28	43.80	5.12	25.90	-12.78	40.50	54.00	-13.50	AV	Vertical
2483.50	65.39	43.80	5.12	25.90	-12.78	52.61	74.00	-21.39	PK	Horizontal
2483.50	52.24	43.80	5.12	25.90	-12.78	39.46	54.00	-14.54	AV	Horizontal
802.11n20										
2390.00	66.85	43.80	4.91	25.90	-12.99	53.86	74.00	-20.14	PK	Vertical
2390.00	52.76	43.80	4.91	25.90	-12.99	39.77	54.00	-14.23	AV	Vertical
2390.00	64.52	43.80	4.91	25.90	-12.99	51.53	74.00	-22.47	PK	Horizontal
2390.00	53.12	43.80	4.91	25.90	-12.99	40.13	54.00	-13.87	AV	Horizontal
2483.50	66.47	43.80	5.12	25.90	-12.78	53.69	74.00	-20.31	PK	Vertical
2483.50	52.52	43.80	5.12	25.90	-12.78	39.74	54.00	-14.26	AV	Vertical
2483.50	65.62	43.80	5.12	25.90	-12.78	52.84	74.00	-21.16	PK	Horizontal
2483.50	52.17	43.80	5.12	25.90	-12.78	39.39	54.00	-14.61	AV	Horizontal



Frequency (MHz)	Reading (dBμV)	Amplifier (dB)	Loss (dB)	Antenna Factor (dB/m)	Corrected Factor (dB)	Emission Level (dBμV/m)	Limits (dBμV/m)	Margin (dB)	Detector Type	Comment
802.11n40										
2390.00	66.09	43.80	4.91	25.90	-12.99	53.10	74.00	-20.90	PK	Vertical
2390.00	52.58	43.80	4.91	25.90	-12.99	39.59	54.00	-14.41	AV	Vertical
2390.00	64.33	43.80	4.91	25.90	-12.99	51.34	74.00	-22.66	PK	Horizontal
2390.00	53.16	43.80	4.91	25.90	-12.99	40.17	54.00	-13.83	AV	Horizontal
2483.50	65.83	43.80	5.12	25.90	-12.78	53.05	74.00	-20.95	PK	Vertical
2483.50	52.31	43.80	5.12	25.90	-12.78	39.53	54.00	-14.47	AV	Vertical
2483.50	65.62	43.80	5.12	25.90	-12.78	52.84	74.00	-21.16	PK	Horizontal
2483.50	52.25	43.80	5.12	25.90	-12.78	39.47	54.00	-14.53	AV	Horizontal

Remark: Factor = Antenna Factor + Cable Loss – Pre-amplifier.
 Low measurement frequencies is range from 2300 to 2422 MHz, high measurement frequencies is range from 2452 to 2500 MHz.
 Only show the worst point data of the emissions in the frequency 2300-2422 MHz and 2452-2500 MHz.

4 CONDUCTED SPURIOUS & BAND EDGE EMISSION

4.1 APPLIED PROCEDURES / LIMIT

According to FCC Part 15.247(d) and RSS-247 Clause 5.5, in any 100kHz bandwidth outside the frequency band in which the spread spectrum or digitally modulated intentional radiator is operating, the radio frequency power that is produced by the intentional radiator shall be at least 20dB below that in the 100kHz bandwidth within the band that contains the highest level of the desired power, based on either an RF conducted or a radiated measurement.

4.2 TEST PROCEDURE

Spectrum Parameter	Setting
Detector	Peak
Start/Stop Frequency	30 MHz to 10th carrier harmonic
RB / VB (emission in restricted band)	100 KHz/300 KHz
Trace-Mode:	Max hold

For Band edge

Spectrum Parameter	Setting
Detector	Peak
Start/Stop Frequency	Lower Band Edge: 2300 to 2422 MHz Upper Band Edge: 2452 to 2500 MHz
RB / VB (emission in restricted band)	100 KHz/300 KHz
Trace-Mode:	Max hold

4.3 DEVIATION FROM STANDARD

No deviation.

4.4 TEST SETUP

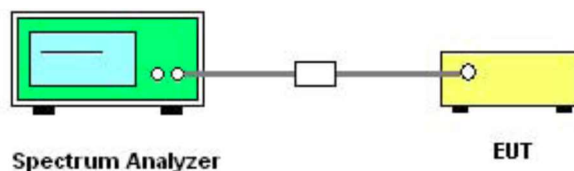

The EUT which is powered by the Battery, is coupled to the Spectrum Analyzer; the RF load attached to the EUT antenna terminal is 50Ohm; the path loss as the factor is calibrated to correct the reading.

Make the measurement with the spectrum analyzer's resolution bandwidth (RBW) = 100 kHz. In order to make an accurate measurement, set the span greater than RBW.

4.5 EUT OPERATION CONDITIONS

The EUT tested system was configured as the statements of 2.3 Unless otherwise a special operating condition is specified in the follows during the testing.



4.6 TEST RESULTS

Temperature :	25 °C	Relative Humidity :	60%
Test Voltage :	DC 3.8V	Test Mode :	TX b Mode /CH01, CH06, CH11

CH 01

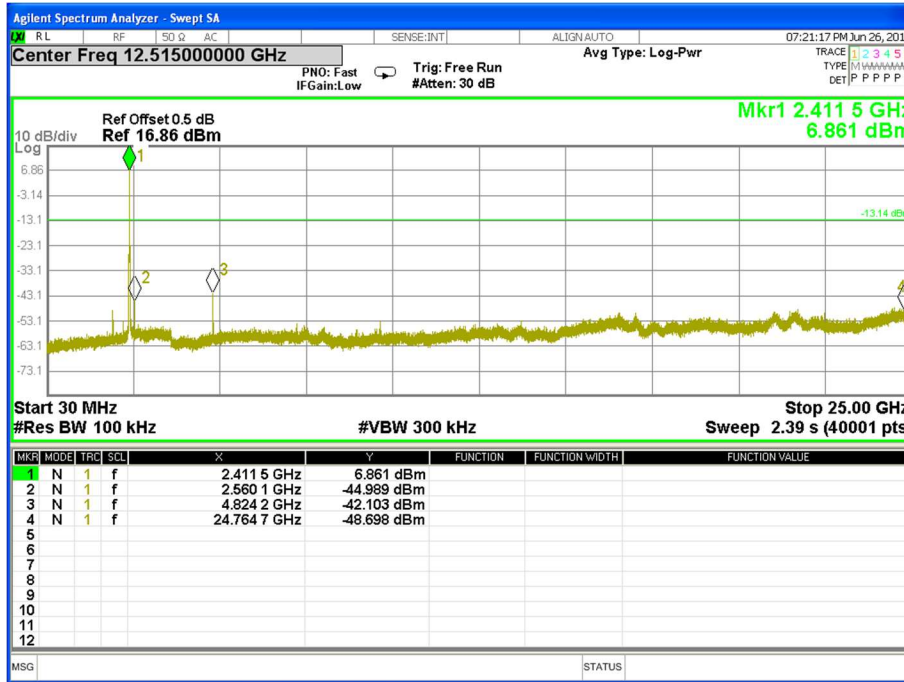

CH 06

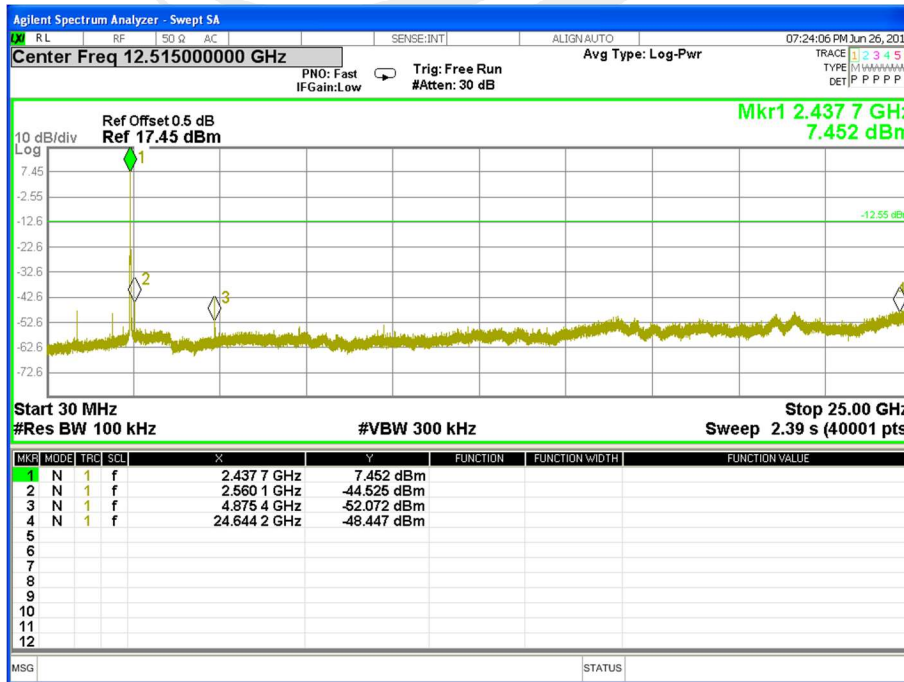



CH 11

