

**CFR 47 FCC PART 15 SUBPART E**

**TEST REPORT**

*For*

**Security Camera**

**MODEL NUMBER: VMC3081, VMC2081**

**REPORT NUMBER: 4791756546-1-RF-3**

**ISSUE DATE: August 1, 2025**

**FCC ID:2APLE18300433**

*Prepared for*

**Arlo Technologies, Inc.  
5770 Fleet St, Suite 200, Carlsbad, CA 92008 USA**

*Prepared by*

**UL Verification Services (Guangzhou) Co., Ltd, Song Shan Lake Branch**

**Room 101, Building 2, No.4, Information Road, Songshan Lake, Dongguan,  
Guangdong, China**

**Tel: +86 769 22038881**

**Fax: +86 769 33244054**

**Website: [www.ul.com](http://www.ul.com)**

The results reported herein have been performed in accordance with the laboratory's terms of accreditation. This report shall not be reproduced except in full without the written approval of the Laboratory. The results in this report apply to the test sample(s) mentioned above at the time of the testing period only and are not to be used to indicate applicability to other similar products.

## Revision History

<u>Rev.</u>	<u>Issue Date</u>	<u>Revisions</u>	<u>Revised By</u>
<u>V0</u>	<u>August 1, 2025</u>	<u>Initial Issue</u>	<u></u>

### Summary of Test Results

Test Item	Clause	Limit/Requirement	Result
ON TIME AND DUTY CYCLE	ANSI C63.10-2013, Clause 12.2	None; for reporting purposes only.	Pass
6dB AND 26dB EMISSION BANDWIDTH AND 99% OCCUPIED BANDWIDTH	KDB 789033 D02 v02r01 Section C.1	FCC Part 15.407 (a)/(e),	Pass
CONDUCTED OUTPUT POWER	KDB 789033 D02 v02r01 Section E.3.a (Method PM)/KDB 789033 D02 v02r01 Section E.3.a (Method PM) Section E.2.d (Method SA-2)	FCC 15.407 (a)	Pass
POWER SPECTRAL DENSITY	KDB 789033 D02 v02r01 Section F	FCC 15.407 (a)	Pass
AC Power Line Conducted Emission	ANSI C63.10-2013, Clause 6.2.	FCC 15.207	Pass
Radiated Emissions and Band Edge Measurement	KDB 789033 D02 v02r01 Section G.3, G.4, G.5, and G.6	FCC 15.407 (b) FCC 15.209 FCC 15.205	Pass
FREQUENCY STABILITY	ANSI C63.10-2013, Clause 6.8	FCC 15.407 (g)	Pass
Dynamic Frequency Selection (Slave)	KDB 905462 D03 UNII Clients Without Radar Detection New Rules v01r02	FCC Part 15.407 (h),	Pass
Antenna Requirement	N/A	FCC 47 CFR Part 15.203/ 15.407(a)(1) (2),	Pass

**Note:**

1. N/A: In this whole report not applicable.

\*This test report is only published to and used by the applicant, and it is not for evidence purpose in China.

\*The measurement result for the sample received is <Pass> according to <CFR 47 FCC PART 15 SUBPART E> when <Simple Acceptance> decision rule is applied.

## CONTENTS

<b>1. ATTESTATION OF TEST RESULTS</b> .....	<b>6</b>
<b>2. TEST METHODOLOGY</b> .....	<b>7</b>
<b>3. FACILITIES AND ACCREDITATION</b> .....	<b>7</b>
<b>4. CALIBRATION AND UNCERTAINTY</b> .....	<b>8</b>
4.1. <i>MEASURING INSTRUMENT CALIBRATION</i> .....	8
4.2. <i>MEASUREMENT UNCERTAINTY</i> .....	8
<b>5. EQUIPMENT UNDER TEST</b> .....	<b>9</b>
5.1. <i>DESCRIPTION OF EUT</i> .....	9
5.2. <i>CHANNEL LIST</i> .....	10
5.3. <i>MAXIMUM POWER</i> .....	11
5.4. <i>TEST CHANNEL CONFIGURATION</i> .....	12
5.5. <i>THE WORSE CASE POWER SETTING PARAMETER</i> .....	13
5.6. <i>DESCRIPTION OF AVAILABLE ANTENNAS</i> .....	14
5.7. <i>SUPPORT UNITS FOR SYSTEM TEST</i> .....	15
<b>6. MEASURING EQUIPMENT AND SOFTWARE USED</b> .....	<b>16</b>
<b>7. ANTENNA PORT TEST RESULTS</b> .....	<b>19</b>
7.1. <i>ON TIME AND DUTY CYCLE</i> .....	19
7.2. <i>6DB AND 26DB EMISSION BANDWIDTH AND 99% OCCUPIED BANDWIDTH</i> ...	20
7.3. <i>CONDUCTED OUTPUT POWER</i> .....	22
7.4. <i>POWER SPECTRAL DENSITY</i> .....	24
7.5. <i>FREQUENCY STABILITY</i> .....	26
7.6. <i>DYNAMIC FREQUENCY SELECTION (SLAVE)</i> .....	28
<b>8. RADIATED TEST RESULTS</b> .....	<b>32</b>
8.1. <i>RESTRICTED BANDEDGE</i> .....	40
8.2. <i>SPURIOUS EMISSIONS(1 GHZ~7 GHZ)</i> .....	82
8.3. <i>SPURIOUS EMISSIONS(7 GHZ~18 GHZ)</i> .....	108
8.4. <i>SPURIOUS EMISSIONS(9 KHZ~30 MHZ)</i> .....	160
8.5. <i>SPURIOUS EMISSIONS(18 GHZ~26 GHZ)</i> .....	163
8.6. <i>SPURIOUS EMISSIONS(26 GHZ~40 GHZ)</i> .....	165
8.7. <i>SPURIOUS EMISSIONS(30 MHZ~1 GHZ)</i> .....	167
<b>9. AC POWER LINE CONDUCTED EMISSION</b> .....	<b>169</b>

<b>10.</b>	<b>ANTENNA REQUIREMENT .....</b>	<b>173</b>
<b>11.</b>	<b>TEST DATA .....</b>	<b>174</b>
11.1.	<i>APPENDIX A: EMISSION BANDWIDTH.....</i>	174
11.1.1.	Test Result .....	174
11.1.2.	Test Graphs .....	175
11.2.	<i>APPENDIX B: OCCUPIED CHANNEL BANDWIDTH .....</i>	184
11.2.1.	Test Result .....	184
11.2.2.	Test Graphs .....	185
11.3.	<i>APPENDIX C: MIN EMISSION BANDWIDTH .....</i>	194
11.3.1.	Test Result .....	194
11.3.2.	Test Graphs .....	195
11.4.	<i>APPENDIX D: MAXIMUM AVG CONDUCTED OUTPUT POWER.....</i>	198
11.4.1.	Test Result .....	198
11.4.2.	Test Graphs .....	199
11.5.	<i>APPENDIX E: MAXIMUM POWER SPECTRAL DENSITY .....</i>	201
11.5.1.	Test Result .....	201
11.5.2.	Test Graphs .....	202
11.6.	<i>APPENDIX F: FREQUENCY STABILITY.....</i>	212
11.6.1.	Test Result .....	212
11.7.	<i>APPENDIX G: DUTY CYCLE.....</i>	213
11.7.1.	Test Result .....	213
11.7.2.	Test Graphs .....	214
11.8.	<i>APPENDIX H: CALIBRATION.....</i>	215
11.9.	<i>APPENDIX I: SHUTDOWN TIME.....</i>	216
11.10.	<i>APPENDIX J: NON-OCCUPANCY .....</i>	217

# 1. ATTESTATION OF TEST RESULTS

## Applicant Information

Company Name: Arlo Technologies, Inc.  
Address: 5770 Fleet St, Suite 200, Carlsbad, CA 92008 USA

## Manufacturer Information

Company Name: Arlo Technologies, Inc.  
Address: 5770 Fleet St, Suite 200, Carlsbad, CA 92008 USA

## EUT Information

EUT Name: Security Camera  
Model: VMC3081  
Series Model: VMC2081  
Sample Received Date: March 20, 2025  
Sample Status: Normal  
Sample ID: 8388280  
Date of Tested: March 21, 2025 to August 1, 2025

APPLICABLE STANDARDS	
STANDARD	TEST RESULTS
CFR 47 FCC PART 15 SUBPART E	Pass

Prepared By:

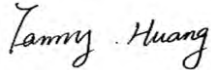

Fanny Huang  
Engineer Project Associate

Checked By:

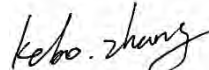

Kebo Zhang  
Senior Project Engineer

Approved By:



Stephen Guo  
Operations Manager

## 2. TEST METHODOLOGY

All tests were performed in accordance with the standard CFR 47 FCC PART 15 SUBPART E, ANSI C63.10-2013, CFR 47 FCC Part 2, KDB 789033 D02 v02r01, KDB 414788 D01 Radiated Test Site v01r01, KDB 905462 D02 UNII DFS Compliance Procedures New Rules v02, KDB 905462 D03 UNII clients without radar detection New Rules v01r02, KDB 905462 D04 Operational Modes for DFS Testing New Rules v01 and KDB 905462 D06 802 11 Channel Plans New Rules v02.

## 3. FACILITIES AND ACCREDITATION

Accreditation Certificate	<p><b>A2LA (Certificate No.: 4102.01)</b>          UL Verification Services (Guangzhou) Co., Ltd. Song Shan Lake Branch. has been assessed and proved to be in compliance with A2LA.</p> <p><b>FCC (FCC Designation No.: CN1187)</b>          UL Verification Services (Guangzhou) Co., Ltd. Song Shan Lake Branch. Has been recognized to perform compliance testing on equipment subject to the Commission's Declaration of Conformity (DoC) and Certification rules.</p> <p><b>ISED (Company No.: 21320)</b>          UL Verification Services (Guangzhou) Co., Ltd. Song Shan Lake Branch. has been registered and fully described in a report filed with ISED. The Company Number is 21320 and the test lab Conformity Assessment Body Identifier (CABID) is CN0046.</p>
---------------------------	---

**Note 1:**

All tests measurement facilities use to collect the measurement data are located at Room 101, Building 2, No.4, Information Road, Songshan Lake, Dongguan, Guangdong, China.

**Note 2:**

The test anechoic chamber in UL Verification Services (Guangzhou) Co., Ltd. Song Shan Lake Branch had been calibrated and compared to the open field sites and the test anechoic chamber is shown to be equivalent to or worst case from the open field site.

**Note 3:**

For below 30 MHz, lab had performed measurements at test anechoic chamber and comparing to measurements obtained on an open field site. And these measurements below 30 MHz had been correlated to measurements performed on an OFS.

## 4. CALIBRATION AND UNCERTAINTY

### 4.1. MEASURING INSTRUMENT CALIBRATION

The measuring equipment utilized to perform the tests documented in this report has been calibrated in accordance with the manufacturer's recommendations and is traceable to recognized national standards.

### 4.2. MEASUREMENT UNCERTAINTY

Where relevant, the following measurement uncertainty levels have been estimated for tests performed on the apparatus:

Test Item	Uncertainty
Conduction emission	3.62 dB
Radiated Emission (Included Fundamental Emission) (9 kHz ~ 30 MHz)	2.2 dB
Radiated Emission (Included Fundamental Emission) (30 MHz ~ 1 GHz)	4.00 dB
Radiated Emission (Included Fundamental Emission) (1 GHz to 40 GHz)	5.78 dB (1 GHz ~ 18 GHz)
	5.23 dB (18 GHz ~ 26 GHz)
	5.37 dB (26 GHz ~ 40 GHz)
Duty Cycle	±0.028%
Emission Bandwidth and 99% Occupied Bandwidth	±0.0196%
Maximum Conducted Output Power	±0.766 dB
Maximum Power Spectral Density Level	±1.22 dB
Frequency Stability	±2.76%
Dynamic Frequency Selection	±1.01 dB
Conducted Band-edge Compliance	±1.328 dB
Conducted Unwanted Emissions In Non-restricted Frequency Bands	±0.746 dB (9 kHz ~ 1 GHz)
	±1.328dB (1 GHz ~ 26 GHz)
Note: This uncertainty represents an expanded uncertainty expressed at approximately the 95% confidence level using a coverage factor of k=2.	



## 5. EQUIPMENT UNDER TEST

### 5.1. DESCRIPTION OF EUT

EUT Name	Security Camera
Model	VMC3081
Series Model	VMC2081
Model Difference	Please refer to the declaration letter.

Frequency Range:	5180 MHz to 5240 MHz 5260 MHz to 5320 MHz 5500 MHz to 5720 MHz 5745 MHz to 5825 MHz
Type of Modulation:	IEEE 802.11a: OFDM(64QAM, 16QAM, QPSK, BPSK) IEEE 802.11n: OFDM(64QAM, 16QAM, QPSK, BPSK)
Radio Technology:	IEEE 802.11a/n HT20
Normal Test Voltage:	AC 120 V, 60 Hz

## 5.2. CHANNEL LIST

UNII-1 (For Bandwidth=20MHz)	
Channel	Frequency (MHz)
36	5180
40	5200
44	5220
48	5240

UNII-2A (For Bandwidth=20MHz)	
Channel	Frequency (MHz)
52	5260
56	5280
60	5300
64	5320

UNII-2C (For Bandwidth=20MHz)	
Channel	Frequency (MHz)
100	5500
104	5520
108	5540
112	5560
116	5580
120	5600
124	5620
128	5640
132	5660
136	5680
140	5700

UNII-3 (For Bandwidth=20MHz)	
Channel	Frequency (MHz)
149	5745
153	5765
157	5785
161	5805
165	5825

Straddle Test Channel Configuration		
IEEE Std.	Test Channel Number	Frequency
802.11a	CH 144	5720 MHz
802.11n HT20	CH 144	5720 MHz

### 5.3. MAXIMUM POWER

IEEE Std. 802.11	Frequency (MHz)	Maximum Average Conducted Power (dBm)	Max Average EIRP (dBm)
a	5180 ~ 5825	22.94	24.74
n HT20		22.76	24.56

## 5.4. TEST CHANNEL CONFIGURATION

UNII-1 Test Channel Configuration

IEEE Std.	Test Channel Number	Frequency
802.11a	CH 36(Low Channel), CH 40(MID Channel), CH 48(High Channel)	5180 MHz, 5200 MHz, 5240 MHz
802.11n HT20	CH 36(Low Channel), CH 40(MID Channel), CH 48(High Channel)	5180 MHz, 5200 MHz, 5240 MHz

UNII-2A Test Channel Configuration

IEEE Std.	Test Channel Number	Frequency
802.11a	CH 52(Low Channel), CH 56(MID Channel), CH 64(High Channel)	5260 MHz, 5280 MHz, 5320 MHz
802.11n HT20	CH 52(Low Channel), CH 56(MID Channel), CH 64(High Channel)	5260 MHz, 5280 MHz, 5320 MHz

UNII-2C Test Channel Configuration

IEEE Std.	Test Channel Number	Frequency
802.11a	CH 100(Low Channel), CH 116(MID Channel), CH 140(High Channel)	5500 MHz, 5580 MHz, 5700 MHz
802.11n HT20	CH 100(Low Channel), CH 116(MID Channel), CH 140(High Channel)	5500 MHz, 5580 MHz, 5700 MHz

UNII-3 Test Channel Configuration

IEEE Std.	Test Channel Number	Frequency
802.11a	CH 149(Low Channel), CH 157(MID Channel), CH 165(High Channel)	5745 MHz, 5785 MHz, 5825 MHz
802.11n HT20	CH 149(Low Channel), CH 157(MID Channel), CH 165(High Channel)	5745 MHz, 5785 MHz, 5825 MHz

Straddle Test Channel Configuration

IEEE Std.	Test Channel Number	Frequency
802.11a	CH 144	5720 MHz
802.11n HT20	CH 144	5720 MHz

## 5.5. THE WORSE CASE POWER SETTING PARAMETER

The Worst Case Power Setting Parameter	
Test Software	CMD

Mode	Freq(MHz)	Tx power setting
		ANT1
802.11a	5180	-6
	5200	-4
	5240	-4
	5260	-4
	5280	-4
	5320	-10
	5500	-5
	5580	1
	5700	-11
	5720-2C	16
	5720-3	16
	5745	16
	5785	16
	5825	16
802.11n 20M	5180	-6
	5200	-4
	5240	-4
	5260	-4
	5280	-4
	5320	-6
	5500	-5
	5580	1
	5700	-12
	5720-2C	16
	5720-3	16
	5745	16
	5785	16
	5825	16

## WORSE CASE CONFIGURATIONS

The EUT was tested in the following configuration(s):

Controlled in test mode using a software application on the EUT supplied by customer. The application was used to enable a continuous transmission and to select the mode, test channels, bandwidth, data rates as required.

Test channels referring to section 5.4.

Maximum power setting referring to section 5.5.

Worst case Data Rates declared by the customer:

802.11a 20 mode: 6 Mbps  
802.11n HT20 mode: MCS0

The measured additional path loss was included in any path loss calculations for all RF cable used during tested.

### 5.6. DESCRIPTION OF AVAILABLE ANTENNAS

Antenna No.	Frequency Band	Antenna Type	Max Antenna Gain (dBi)
1	5150-5850	PIFA antenna	1.80

IEE Std. 802.11	Transmit and Receive Mode	Description
802.11a	<input checked="" type="checkbox"/> 1TX, 1RX	ANT 1 can be used as transmitting/receiving antenna.
802.11n HT20	<input checked="" type="checkbox"/> 1TX, 1RX	ANT 1 can be used as transmitting/receiving antenna.

Note:

1. BLE & WLAN 2.4G, BLE & WLAN 5G, WLAN 2.4G & WLAN 5G can't transmit simultaneously (Declared by client)

## 5.7. SUPPORT UNITS FOR SYSTEM TEST

### SUPPORT EQUIPMENT

Item	Equipment	Brand Name	Model Name	Remarks
1	Laptop	Lenovo	E42-80	R303U5AG

### I/O CABLES

Cable No	Port	Connector Type	Cable Type	Cable Length(m)	Remarks
1	USB	/	/	1.0	/

### ACCESSORIES

Item	Accessory	Brand Name	Model Name	Description
1	Power Adapter	/	GTF9V1C-C	Input: AC 100-240V, 50/60Hz, 0.3A Output: DC 9.0V, 1.0A, 9.0W
2	Power Adapter	/	AD2151321	Input: AC 100-240V, 50/60Hz, 0.3A Output: DC 6.6V, 1.0A
3	POE	/	VMA3900	Input: 37-57 VDC Output: DC 5V, 2A

Note: All the Power Adapter and POE have been pre-tested, and only the worst data was recorded in the report.

### TEST SETUP

The EUT can work in engineering mode with a software through a Laptop.

### SETUP DIAGRAM FOR TESTS

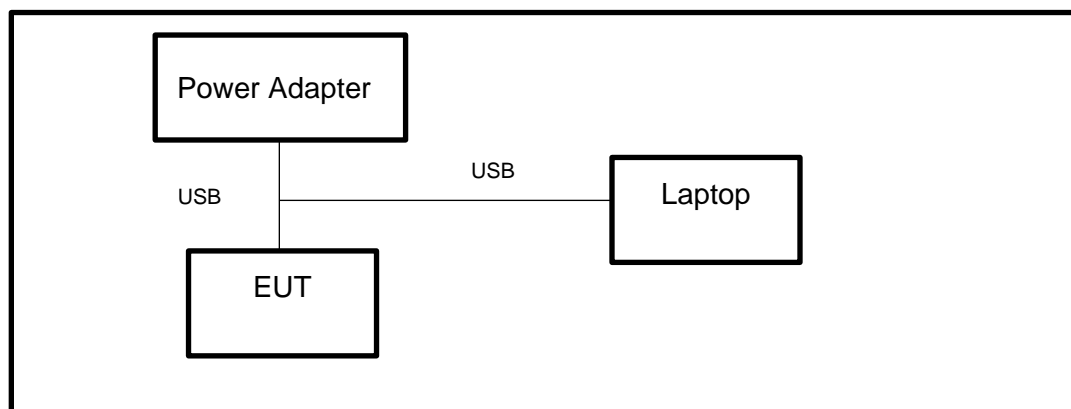

## 6. MEASURING EQUIPMENT AND SOFTWARE USED

R&S TS 8997 Test System					
Equipment	Manufacturer	Model No.	Serial No.	Last Cal.	Due. Date
Power sensor, Power Meter	R&S	OSP120	100921	Dec.27,2024	Dec.26,2025
Vector Signal Generator	R&S	SMBV100A	261637	Sep.28, 2024	Sep.27, 2025
Signal Generator	R&S	SMB100A	178553	Sep.28, 2024	Sep.27, 2025
Signal Analyzer	R&S	FSV40	101118	Sep.28, 2024	Sep.27, 2025
Software					
Description	Manufacturer	Name		Version	
For R&S TS 8997 Test System	Rohde & Schwarz	EMC 32		10.60.10	
Tonsend RF Test System					
Equipment	Manufacturer	Model No.	Serial No.	Last Cal.	Due. Date
Wireless Connectivity Tester	R&S	CMW270	1201.0002N75-102	Sep.13, 2024	Sep.12, 2025
PXA Signal Analyzer	Keysight	N9030A	MY55410512	Sep.28, 2024	Sep.27, 2025
MXG Vector Signal Generator	Keysight	N5182B	MY56200284	Sep.28, 2024	Sep.27, 2025
MXG Vector Signal Generator	Keysight	N5172B	MY56200301	Sep.28, 2024	Sep.27, 2025
DC power supply	Keysight	E3642A	MY55159130	Sep.28, 2024	Sep.27, 2025
Temperature & Humidity Chamber	SANMOOD	SG-80-CC-2	2088	Sep.28, 2024	Sep.27, 2025
Attenuator	Aglient	8495B	2814a12853	Sep.28, 2024	Sep.27, 2025
RF Control Unit	Tonscend	JS0806-2	23B80620666	Dec.27,2024	Dec.26,2025
Software					
Description	Manufacturer	Name		Version	
Tonsend SRD Test System	Tonsend	JS1120-3 RF Test System		V3.2.22	



Conducted Emissions					
Equipment	Manufacturer	Model No.	Serial No.	Last Cal.	Due Date
EMI Test Receiver	R&S	ESR3	101961	Sep.28, 2024	Sep.27, 2025
Two-Line V-Network	R&S	ENV216	101983	Sep.28, 2024	Sep.27, 2025
Artificial Mains Networks	Schwarzbeck	NSLK 8126	8126465	Sep.28, 2024	Sep.27, 2025
Software					
Description			Manufacturer	Name	Version
Test Software for Conducted Emissions			Farad	EZ-EMC	Ver. UL-3A1

Radiated Emissions					
Equipment	Manufacturer	Model No.	Serial No.	Last Cal.	Due Date
MXE EMI Receiver	KESIGHT	N9038A	MY56400036	Sep.28, 2024	Sep.27, 2025
Hybrid Log Periodic Antenna	TDK	HLP-3003C	130960	June 28, 2024	June.27 2027
Preamplifier	HP	8447D	2944A09099	Sep.28, 2024	Sep.27, 2025
EMI Measurement Receiver	R&S	ESR26	101377	Sep.28, 2024	Sep.27, 2025
Horn Antenna	TDK	HRN-0118	130940	Dec.10, 2024	Dec.11, 2027
Preamplifier	TDK	PA-02-0118	TRS-305-00067	Sep.28, 2024	Sep.27, 2025
Horn Antenna	Schwarzbeck	BBHA9170	697	Jun 30, 2024	Jun 29, 2027
Preamplifier	TDK	PA-02-2	TRS-307-00003	Sep.28, 2024	Sep.27, 2025
Preamplifier	TDK	PA-02-3	TRS-308-00002	Sep.28, 2024	Sep.27, 2025
Loop antenna	Schwarzbeck	1519B	00008	Dec.09, 2024	Dec.08, 2027
High Pass Filter	Wi	W-40SS	23	Sep.28, 2024	Sep.27, 2025
Highpass Filter	Wainwright	WHKX10-5850-6500-1800-40SS	4	Sep.28, 2024	Sep.27, 2025
Band Reject Filter	Wainwright	WRCJV12-5695-5725-5850-5880-40SS	4	Sep.28, 2024	Sep.27, 2025
Band Reject Filter	Wainwright	WRCJV20-5120-5150-5350-5380-60SS	2	Sep.28, 2024	Sep.27, 2025
Band Reject Filter	Wainwright	WRCJV20-5440-5470-	1	Sep.28, 2024	Sep.27, 2025

		5725-5755-60SS			
Software					
Description		Manufacturer	Name	Version	
Test Software for Radiated Emissions		Farad	EZ-EMC	Ver. UL-3A1	

Other Instrument					
Equipment	Manufacturer	Model No.	Serial No.	Last Cal.	Due Date
Temperature humidity probe	OMEGA	ITHX-SD-5	18470007	Oct.8, 2024	Oct.7, 2025
Barometer	Yiyi	Baro	N/A	Oct.10, 2024	Oct.9, 2025
Attenuator	Agilent	8495B	2814a12853	Sep.28, 2024	Sep.27, 2025

## 7. ANTENNA PORT TEST RESULTS

### 7.1. ON TIME AND DUTY CYCLE

#### LIMITS

None; for reporting purposes only.

#### TEST PROCEDURE

Refer to KDB 789033 D02 General U-NII Test Procedures New Rules v02r01 section II.B.

The zero-span mode on a spectrum analyzer or EMI receiver, if the response time and spacing between bins on the sweep are sufficient to permit accurate measurements of the on and off times of the transmitted signal. Set the center frequency of the instrument to the center frequency of the transmission. Set  $RBW \geq EBW$  if possible; otherwise, set RBW to the largest available value. Set  $VBW \geq RBW$ . Set detector = peak or average. The zero-span measurement method shall not be used unless both RBW and VBW are  $> 50/T$ , where T is defined in II.B.1.a), and the number of sweep points across duration T exceeds 100. (For example, if VBW and/or RBW are limited to 3 MHz, then the zero-span method of measuring duty cycle shall not be used if  $T \leq 16.7$  microseconds.)

#### TEST SETUP

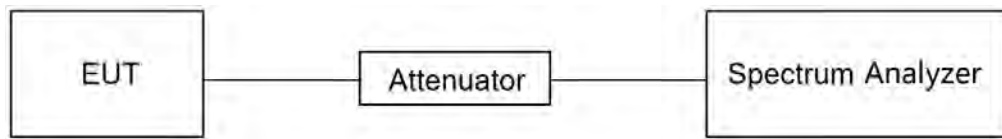

#### TEST ENVIRONMENT

Temperature	22.8°C	Relative Humidity	58%
Atmosphere Pressure	101kPa	Test Voltage	AC 120V 60Hz

#### TEST DATE / ENGINEER

Test Date	March 21, 2025	Test By	Walker Yuan
-----------	----------------	---------	-------------

#### TEST RESULTS

Please refer to section "Test Data" - Appendix G

## 7.2. 6DB AND 26DB EMISSION BANDWIDTH AND 99% OCCUPIED BANDWIDTH

### LIMITS

CFR 47 FCC Part15, Subpart E		
Test Item	Limit	Frequency Range (MHz)
26 dB Emission Bandwidth	For reporting purposes only.	5150 ~ 5250
26 dB Emission Bandwidth	For reporting purposes only.	5250 ~ 5350
26 dB Emission Bandwidth	For reporting purposes only.	5470 ~ 5725
6 dB Emission Bandwidth	The minimum 6 dB emission bandwidth shall be 500 kHz.	5725 ~ 5850
99 % Occupied Bandwidth	For reporting purposes only.	5150 ~ 5825

### TEST PROCEDURE

Refer to KDB 789033 D02 General U-NII Test Procedures New Rules v02r01 section II.C1. for 26 dB Emission Bandwidth; section II.C2. for 6 dB Emission Bandwidth; section II.D. for 99 % Occupied Bandwidth.

Connect the EUT to the spectrum analyser and use the following settings:

Center Frequency	The center frequency of the channel under test
Detector	Peak
RBW	For 6 dB Emission Bandwidth: RBW=100 kHz For 26 dB Emission bandwidth: approximately 1 % of the EBW. For 99 % Occupied Bandwidth: approximately 1 % ~ 5 % of the OBW.
VBW	For 6 dB Bandwidth: $\geq 3 \times \text{RBW}$ For 26 dB Bandwidth: $> 3 \times \text{RBW}$ For 99 % Bandwidth: $> 3 \times \text{RBW}$
Trace	Max hold
Sweep	Auto couple

- Use the 99 % power bandwidth function of the instrument, allow the trace to stabilize and report the measured bandwidth.
- Allow the trace to stabilize and measure the maximum width of the emission that is constrained by the frequencies associated with the two outermost amplitude points (upper and lower frequencies) that are attenuated by 6/26 dB relative to the maximum level measured in the fundamental emission.

### Calculation for 99 % Bandwidth of UNII-2C and UNII-3 Straddle Channel:

For Example: Fundamental Frequency: 5720 MHz

99 % OBW: 21.00 MHz

Turning Frequency: 5725 MHz

99 % Bandwidth of UNII-2C Band Portion =  $(5725 - (5720 - (21.00/2))) = 15.50 \text{ MHz}$

99 % Bandwidth of UNII-3 Band Portion =  $(5720 + (21.00/2) - 5725) = 5.50 \text{ MHz}$

**Calculation for 26 dB Bandwidth of UNII-2C Straddle Channel:**

For Example: Fundamental frequency: 5720 MHz

26 dB BW: 20.00 MHz

FL: 5710.16 MHz

FH: 5730.16 MHz

Turning Frequency: 5725 MHz

26 dB Bandwidth of UNII-2C Band Portion = 5725-5710.16=14.84 MHz

**Calculation for 6dB Bandwidth of UNII-3 Straddle Channel:**

For Example: Fundamental frequency: 5720 MHz

6 dB BW: 16.44 MHz

FL: 5711.76 MHz

FH: 5728.2 MHz

Turning Frequency: 5725 MHz

6 dB Bandwidth of UNII-3 band Portion = 5728.2-5725=3.2 MHz

**TEST SETUP**

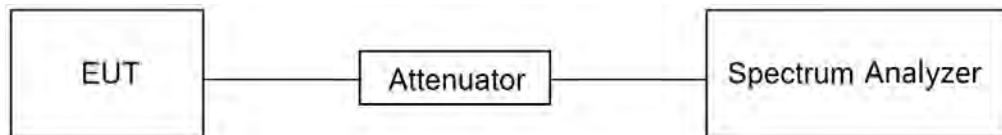

**TEST ENVIRONMENT**

Temperature	22.1°C	Relative Humidity	54%
Atmosphere Pressure	101kPa	Test Voltage	AC 120V 60Hz

**TEST DATE / ENGINEER**

Test Date	June 12, 2025	Test By	Walker Yuan
-----------	---------------	---------	-------------

**TEST RESULTS**

Please refer to section "Test Data" - Appendix A & B & C

### 7.3. CONDUCTED OUTPUT POWER

#### LIMITS

CFR 47 FCC Part15, Subpart E		
Test Item	Limit	Frequency Range (MHz)
Conducted Output Power	<input type="checkbox"/> Outdoor Access Point: 1 W (30 dBm) <input type="checkbox"/> Indoor Access Point: 1 W (30 dBm) <input type="checkbox"/> Fixed Point-To-Point Access Points: 1 W (30 dBm) <input checked="" type="checkbox"/> Client Devices: 250 mW (24 dBm)	5150 ~ 5250
	Shall not exceed the lesser of 250 mW (24dBm) or 11 dBm + 10 log B, where B is the 26 dB emission bandwidth in megahertz.	5250 ~ 5350 5470 ~ 5725
	Shall not exceed 1 Watt (30 dBm).	5725 ~ 5850

#### Note:

The above limits are based upon the maximum antenna gain does not exceed 6 dBi. If transmitting antennas of directional gain greater than 6 dBi are used, the maximum conducted output power shall be reduced by the amount in dB that the directional gain of the antenna exceeds 6 dBi.

#### TEST PROCEDURE

Refer to KDB 789033 D02 General U-NII Test Procedures New Rules v02r01 section II.E.

#### Method SA-2 (trace averaging across ON and OFF times of the EUT transmissions, followed by duty cycle correction.):

- (a) Measure the duty cycle D of the transmitter output signal.
- (b) Set span to encompass the entire 26 dB EBW or 99% OBW of the signal.
- (c) Set RBW = 1 MHz.
- (d) Set VBW  $\geq$  3 MHz.
- (e) Number of points in sweep  $\geq$   $[2 \times \text{span} / \text{RBW}]$ . (This gives bin-to-bin spacing  $\leq$  RBW / 2, so that narrowband signals are not lost between frequency bins.)
- (f) Sweep time = auto.
- (g) Detector = RMS (i.e., power averaging), if available. Otherwise, use sample detector mode.
- (h) Do not use sweep triggering. Allow the sweep to "free run."
- (i) Trace average at least 100 traces in power averaging (rms) mode; however, the number of traces to be averaged shall be increased above 100 as needed such that the average accurately represents the true average over the ON and OFF periods of the transmitter.
- (j) Compute power by integrating the spectrum across the 26 dB EBW or 99% OBW of the signal using the instrument's band power measurement function with band limits set equal to the EBW or OBW band edges. If the instrument does not have a band power function, then sum the spectrum levels (in power units) at 1 MHz intervals extending across the 26 dB EBW or 99% OBW of the spectrum.
- (k) Add  $[10 \log (1 / D)]$ , where D is the duty cycle, to the measured power to compute the average power during the actual transmission times (because the measurement represents an average over both the ON and OFF times of the transmission). For example, add  $[10 \log (1 / 0.25)] = 6$  dB if the duty cycle is 25%.

**Method PM (Measurement using an RF average power meter):**

- (i) Measurements may be performed using a wideband RF power meter with a thermocouple detector or equivalent if all of the following conditions are satisfied:
  - a. The EUT is configured to transmit continuously or to transmit with a constant duty cycle.
  - b. At all times when the EUT is transmitting, it must be transmitting at its maximum power control level.
  - c. The integration period of the power meter exceeds the repetition period of the transmitted signal by at least a factor of five.
- (ii) If the transmitter does not transmit continuously, measure the duty cycle, x, of the transmitter output signal as described in II.B.
- (iii) Measure the average power of the transmitter. This measurement is an average over both the on and off periods of the transmitter.
- (iv) Adjust the measurement in dBm by adding  $10 \log (1/x)$  where x is the duty cycle (e.g.,  $10 \log (1/0.25)$  if the duty cycle is 25 %).

Note: Method SA-2 was used for straddle channel output power test, and Method PM was used for testing rest channels

**TEST SETUP**

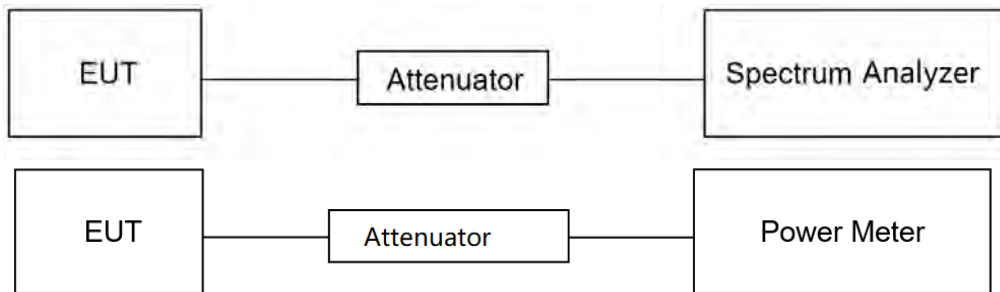

**TEST ENVIRONMENT**

Temperature	22.1°C	Relative Humidity	54%
Atmosphere Pressure	101kPa	Test Voltage	AC 120V 60Hz

**TEST DATE / ENGINEER**

Test Date	June 12, 2025	Test By	Walker Yuan
-----------	---------------	---------	-------------

**TEST RESULTS**

Please refer to section "Test Data" - Appendix D

## 7.4. POWER SPECTRAL DENSITY

### LIMITS

CFR 47 FCC Part15, Subpart E		
Test Item	Limit	Frequency Range (MHz)
Power Spectral Density	<input type="checkbox"/> Outdoor Access Point: 17 dBm/MHz <input type="checkbox"/> Indoor Access Point: 17 dBm/MHz <input type="checkbox"/> Fixed Point-To-Point Access Points: 17 dBm/MHz <input checked="" type="checkbox"/> Client Devices: 11 dBm/MHz	5150 ~ 5250
	11 dBm/MHz	5250 ~ 5350 5470 ~ 5725
	30 dBm/500kHz	5725 ~ 5850

Note:

The above limits are based upon the maximum antenna gain does not exceed 6 dBi.

If transmitting antennas of directional gain greater than 6 dBi are used, maximum power spectral density shall be reduced by the amount in dB that the directional gain of the antenna exceeds 6 dBi.

### TEST PROCEDURE

Refer to KDB 789033 D02 General U-NII Test Procedures New Rules v02r01 section II.F.

Connect the EUT to the spectrum analyzer and use the following settings:

For U-NII-1, U-NII-2A and U-NII-2C band:

Center Frequency	The center frequency of the channel under test
Detector	RMS
RBW	1 MHz
VBW	$\geq 3 \times$ RBW
Span	Encompass the entire emissions bandwidth (EBW) of the signal
Trace	Average
Sweep time	Auto

For U-NII-3:

Center Frequency	The center frequency of the channel under test
Detector	RMS
RBW	500 kHz
VBW	$\geq 3 \times$ RBW
Span	Encompass the entire emissions bandwidth (EBW) of the signal
Trace	Average
Sweep time	Auto



Allow trace to fully stabilize and use the peak search function on the instrument to find the peak of the spectrum and record its value.  
Add  $10 \log(1/x)$ , where  $x$  is the duty cycle, to the peak of the spectrum, the result is the Maximum PSD over 1 MHz / 500 kHz reference bandwidth.

**TEST SETUP**

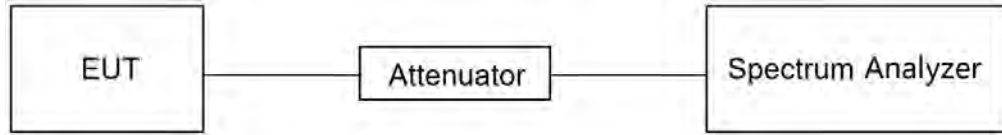

**TEST ENVIRONMENT**

Temperature	22.8°C	Relative Humidity	58%
Atmosphere Pressure	101kPa	Test Voltage	AC 120V 60Hz

**TEST DATE / ENGINEER**

Test Date	March 21, 2025	Test By	Walker Yuan
-----------	----------------	---------	-------------

**TEST RESULTS**

Please refer to section "Test Data" - Appendix E

## 7.5. FREQUENCY STABILITY

### LIMITS

The frequency of the carrier signal shall be maintained within band of operation.

### TEST PROCEDURE

1. The EUT was placed inside an environmental chamber as the temperature in the chamber was varied between -20 °C ~ 45 °C (declared by customer).
2. The temperature was incremented by 10 °C intervals and the unit allowed to stabilize at each temperature before each measurement. The center frequency of the transmitting channel was evaluated at each temperature and the frequency deviation from the channel's center frequency was recorded.
3. The primary supply voltage is varied from 85 % to 115 % of the nominal value for non hand-carried battery and AC powered equipment. For hand-carried, battery-powered equipment, primary supply voltage is reduced to the battery operating end point which shall be specified by the manufacturer.

Connect the EUT to the spectrum analyzer and use the following settings:

Center Frequency	The center frequency of the channel under test
Detector	Peak
RBW	10 kHz
VBW	$\geq 3 \times \text{RBW}$
Span	Encompass the entire emissions bandwidth (EBW) of the signal
Trace	Max hold
Sweep time	Auto

4. While maintaining a constant temperature inside the environmental chamber, turn the EUT on and record the operating frequency at startup, and at 2 minutes, 5 minutes, and 10 minutes after the EUT is energized.
5. Allow the trace to stabilize, find the peak value of the power envelope and record the frequency, then calculated the frequency drift.

### TEST ENVIRONMENT

	Normal Test Conditions	Extreme Test Conditions
Relative Humidity	20 % ~ 75 %	/
Atmospheric Pressure	100 kPa ~ 102 kPa	/
Temperature	T <sub>N</sub> (Normal Temperature): 25.1 °C	T <sub>L</sub> (Low Temperature): -20 °C
		T <sub>H</sub> (High Temperature): 45 °C
Supply Voltage	V <sub>N</sub> (Normal Voltage): AC 120V, 60 Hz	V <sub>L</sub> (Low Voltage): AC 102V
		V <sub>H</sub> (High Voltage): AC 138 V

**TEST SETUP**

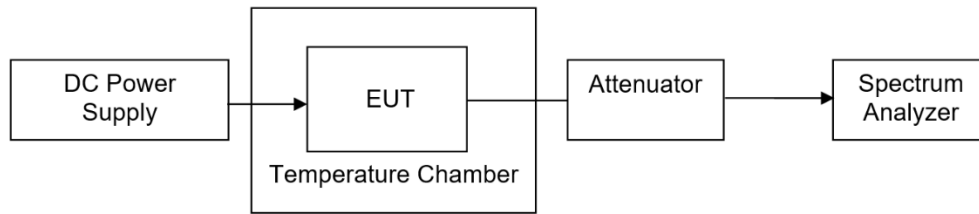

**TEST ENVIRONMENT**

Temperature	21.6°C	Relative Humidity	55.3%
Atmosphere Pressure	101kPa	/	/

**TEST DATE / ENGINEER**

Test Date	June 17, 2025	Test By	Fanny Huang
-----------	---------------	---------	-------------

**TEST RESULTS**

Please refer to section "Test Data" - Appendix F

## 7.6. DYNAMIC FREQUENCY SELECTION (SLAVE)

### LIMITS

#### (1) DFS Detection Thresholds

Table 3: DFS Detection Thresholds for Master Devices and Client Devices With Radar Detection

Maximum Transmit Power	Value (See Notes 1, 2, and 3)
EIRP $\geq$ 200 milliwatt	-64 dBm
EIRP < 200 milliwatt and power spectral density < 10 dBm/MHz	-62 dBm
EIRP < 200 milliwatt that do not meet the power spectral density requirement	-64 dBm

Note 1: This is the level at the input of the receiver assuming a 0 dBi receive antenna.

Note 2: Throughout these test procedures an additional 1 dB has been added to the amplitude of the test transmission waveforms to account for variations in measurement equipment. This will ensure that the test signal is at or above the detection threshold level to trigger a DFS response.

Note3: EIRP is based on the highest antenna gain. For MIMO devices refer to KDB Publication 662911 D01.

#### (2) DFS Response Requirements

Table 4: DFS Response Requirement Values

Parameter	Value
Non-occupancy period	Minimum 30 minutes
Channel Availability Check Time	60 seconds
Channel Move Time	10 seconds See Note 1.
Channel Closing Transmission Time	200 milliseconds + an aggregate of 60 milliseconds over remaining 10 second period. See Notes 1 and 2.
U-NII Detection Bandwidth	Minimum 100% of the U-NII 99% transmission power bandwidth. See Note 3.

Note 1: Channel Move Time and the Channel Closing Transmission Time should be performed with Radar Type 0. The measurement timing begins at the end of the Radar Type 0 burst.

Note 2: The Channel Closing Transmission Time is comprised of 200 milliseconds starting at the beginning of the Channel Move Time plus any additional intermittent control signals required facilitating a Channel move (an aggregate of 60 milliseconds) during the remainder of the 10 second period. The aggregate duration of control signals will not count quiet periods in between transmissions.

Note 3: During the U-NII Detection Bandwidth detection test, radar type 0 should be used. For each frequency step the minimum percentage of detection is 90 percent. Measurements are performed with no data traffic.

## APPLICABILITY OF DFS REQUIREMENTS

A U-NII network will employ a DFS function to detect signals from radar systems and to avoid co-channel operation with these systems. This applies to the 5250-5350 MHz and/or 5470-5725 MHz bands.

Within the context of the operation of the DFS function, a U-NII device will operate in either Master Mode or Client Mode. U-NII devices operating in Client Mode can only operate in a network controlled by a U-NII device operating in Master Mode.

Table 1: Applicability of DFS Requirements Prior to Use of a Channel

Requirement	Operational Mode		
	<input type="checkbox"/> Master	<input checked="" type="checkbox"/> Client Without Radar Detection	<input type="checkbox"/> Client With Radar Detection
Non-Occupancy Period	Yes	Not required	Yes
DFS Detection Threshold	Yes	Not required	Yes
Channel Availability Check Time	Yes	Not required	Not required
U-NII Detection Bandwidth	Yes	Not required	Yes

Table 2: Applicability of DFS requirements during normal operation

Requirement	Operational Mode	
	<input type="checkbox"/> Master Device or Client with Radar Detection	<input checked="" type="checkbox"/> Client Without Radar Detection
DFS Detection Threshold	Yes	Not required
Channel Closing Transmission Time	Yes	Yes
Channel Move Time	Yes	Yes
U-NII Detection Bandwidth	Yes	Not required

Additional requirements for devices with multiple bandwidth modes	<input type="checkbox"/> Master Device or Client with Radar Detection	<input checked="" type="checkbox"/> Client Without Radar Detection
U-NII Detection Bandwidth and Statistical Performance Check	All BW modes must be tested	Not required
Channel Move Time and Channel Closing Transmission Time	Test using widest BW mode available	Test using the widest BW mode available for the link
All other tests	Any single BW mode	Not required

Note: Frequencies selected for statistical performance check should include several frequencies within the radar detection bandwidth and frequencies near the edge of the radar detection bandwidth. For 802.11 devices it is suggested to select frequencies in each of the bonded 20 MHz channels and the channel center frequency.

**PARAMETERS OF RADAR TEST WAVEFORMS**

This section provides the parameters for required test waveforms, minimum percentage of successful detections, and the minimum number of trials that must be used for determining DFS conformance. Step intervals of 0.1 microsecond for Pulse Width, 1 microsecond for PRI, 1 MHz for chirp width and 1 for the number of pulses will be utilized for the random determination of specific test waveforms.

Table 5 Short Pulse Radar Test Waveforms

Radar Type	Pulse Width (µsec)	PRI (µsec)	Number of Pulses	Minimum Percentage of Successful Detection	Minimum Number of Trials
0	1	1428	18	See Note 1	See Note 1
1	1	Test A	Roundup $\left( \frac{f}{360} \right)$	60%	30
		Test B			
2	1-5	150-230	23-29	60%	30
3	6-10	200-500	16-18	60%	30
4	11-20	200-500	12-16	60%	30
Aggregate (Radar Types 1-4)				80%	120

Note 1: Short Pulse Radar Type 0 should be used for the detection bandwidth test, channel move time, and channel closing time tests.  
 Test A: 15 unique PRI values randomly selected from the list of 23 PRI values in Table 5a.  
 Test B: 15 unique PRI values randomly selected within the range of 518-3066 µsec, with a minimum increment of 1 µsec, excluding PRI values selected in Test A

A minimum of 30 unique waveforms are required for each of the Short Pulse Radar Types 2 through 4. If more than 30 waveforms are used for Short Pulse Radar Types 2 through 4, then each additional waveform must also be unique and not repeated from the previous waveforms. If more than 30 waveforms are used for Short Pulse Radar Type 1, then each additional waveform is generated with Test B and must also be unique and not repeated from the previous waveforms in Tests A or B. Test aggregate is average of the percentage of successful detections of short pulse radar types 1-4.

**TEST SETUP**

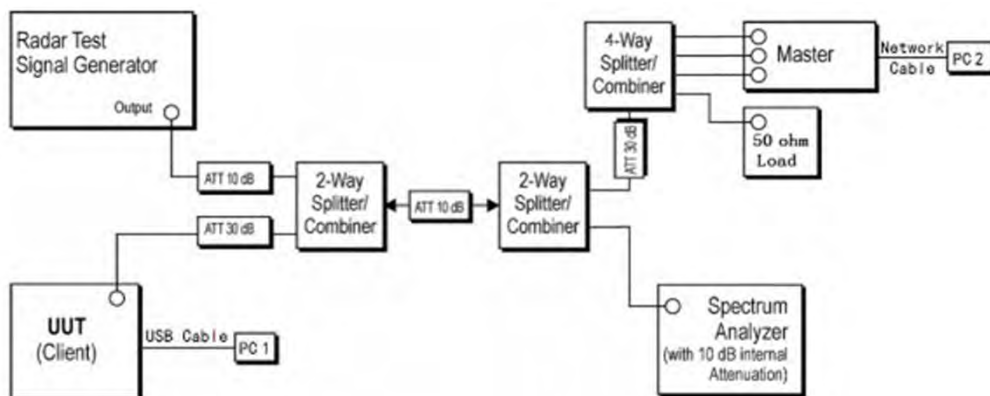

**TEST ENVIRONMENT**

Temperature	21.6°C	Relative Humidity	55.3%
Atmosphere Pressure	101kPa	Test Voltage	AC 120V 60Hz

**TEST DATE / ENGINEER**

Test Date	June 17, 2025	Test By	Fanny Huang
-----------	---------------	---------	-------------

**TEST RESULTS**

Please refer to section "Test Data" - Appendix H&I&J

## 8. RADIATED TEST RESULTS

### LIMITS

Refer to CFR 47 FCC §15.205, §15.209 and §15.407 (b).

Radiation Disturbance Test Limit for FCC (Class B) (9 kHz ~ 1 GHz)

Emissions radiated outside of the specified frequency bands above 30 MHz			
Frequency Range (MHz)	Field Strength Limit (uV/m) at 3 m	Field Strength Limit (dBuV/m) at 3 m	
		Quasi-Peak	
30 - 88	100	40	
88 - 216	150	43.5	
216 - 960	200	46	
Above 960	500	54	
Above 1000	500	Peak	Average
		74	54

FCC Emissions radiated outside of the specified frequency bands below 30 MHz		
Frequency (MHz)	Field strength (microvolts/meter)	Measurement distance (meters)
0.009-0.490	2400/F(kHz)	300
0.490-1.705	24000/F(kHz)	30
1.705-30.0	30	30



FCC Restricted bands of operation refer to FCC §15.205 (a):

MHz	MHz	MHz	GHz
0.090-0.110	16.42-16.423	399.9-410	4.5-5.15
<sup>1</sup> 0.495-0.505	16.69475-16.69525	608-614	5.35-5.46
2.1735-2.1905	16.80425-16.80475	960-1240	7.25-7.75
4.125-4.128	25.5-25.67	1300-1427	8.025-8.5
4.17725-4.17775	37.5-38.25	1435-1626.5	9.0-9.2
4.20725-4.20775	73-74.6	1645.5-1646.5	9.3-9.5
6.215-6.218	74.8-75.2	1660-1710	10.6-12.7
6.26775-6.26825	108-121.94	1718.8-1722.2	13.25-13.4
6.31175-6.31225	123-138	2200-2300	14.47-14.5
8.291-8.294	149.9-150.05	2310-2390	15.35-16.2
8.362-8.366	156.52475-156.52525	2483.5-2500	17.7-21.4
8.37625-8.38675	156.7-156.9	2690-2900	22.01-23.12
8.41425-8.41475	162.0125-167.17	3260-3267	23.6-24.0
12.29-12.293	167.72-173.2	3332-3339	31.2-31.8
12.51975-12.52025	240-285	3345.8-3358	36.43-36.5
12.57675-12.57725	322-335.4	3600-4400	( <sup>2</sup> )
13.36-13.41			

Note: <sup>1</sup>Until February 1, 1999, this restricted band shall be 0.490-0.510 MHz.

<sup>2</sup>Above 38.6c

Limits of unwanted/undesirable emission out of the restricted bands refer to CFR 47 FCC §15.407 (b).

LIMITS OF RADIATED EMISSION MEASUREMENT (Above 1GHz)		
Frequency Range (MHz)	EIRP Limit	Field Strength Limit (dBuV/m) at 3 m
5150~5250 MHz	PK: -27 (dBm/MHz)	PK: 68.2(dBμV/m)
5250~5350 MHz		
5470~5725 MHz		
5725~5850 MHz	PK: -27 (dBm/MHz) *1 PK: 10 (dBm/MHz) *2 PK: 15.6 (dBm/MHz) *3 PK: 27 (dBm/MHz) *4	PK: 68.2(dBμV/m) *1 PK: 105.2 (dBμV/m) *2 PK: 110.8(dBμV/m) *3 PK: 122.2 (dBμV/m) *4
Note: *1 beyond 75 MHz or more above of the band edge. *2 below the band edge increasing linearly to 10 dBm/MHz at 25 MHz above. *3 below the band edge increasing linearly to a level of 15.6 dBm/MHz at 5 MHz above. *4 from 5 MHz above or below the band edge increasing linearly to a level of 27 dBm/MHz at the band edge.		

## TEST PROCEDURE

Below 30 MHz

The setting of the spectrum analyzer

RBW	200 Hz (From 9 kHz to 0.15 MHz)/ 9 kHz (From 0.15 MHz to 30 MHz)
VBW	200 Hz (From 9 kHz to 0.15 MHz)/ 9 kHz (From 0.15 MHz to 30 MHz)
Sweep	Auto

1. The testing follows the guidelines in ANSI C63.10-2013 clause 6.4.
2. The EUT was arranged to its worst case and then turntable (from 0 degree to 360 degrees) to find the maximum reading. A pre-amp and a high pass filter are used for the test in order to get better signal level. Both Horizontal, Face-on and Face-off polarizations of the antenna are set to make the measurement.
3. The EUT was placed on a turntable with 80 cm above ground.
4. The EUT was set 3 meters from the interference receiving antenna, which was mounted on the top of a 1 m height antenna tower.
5. The radiated emission limits are based on measurements employing a CISPR quasi-peak detector except for the frequency bands 9-90 kHz, 110-490 kHz and above 1000 MHz Radiated emission limits in these three bands are based on measurements employing an average detector.
6. For measurement below 1 GHz, the initial step in collecting conducted emission data is a spectrum analyzer peak detector mode pre-scanning the measurement frequency range. Significant peaks are then marked and then Quasi Peak and average detector mode re-measured. If the emission level of the EUT measured by the peak detector is 3 dB lower than the applicable limit, the peak emission level will be reported. Otherwise, the emission measurement will be repeated using the quasi-peak and average detector and reported.
7. Although these tests were performed other than open field site, adequate comparison measurements were confirmed against 30m open field site. Therefore sufficient tests were made to demonstrate that the alternative site produces results that correlate with the ones of tests made in an open field site based on KDB 414788.
8. The limits in CFR 47, Part 15, Subpart C, paragraph 15.209 (a), are identical to those in RSS-GEN Section 8.9, Table 6, since the measurements are performed in terms of magnetic field strength and converted to electric field strength levels (as reported in the table) using the free space impedance of  $377\Omega$ . For example, the measurement frequency X kHz resulted in a level of Y dBuV/m, which is equivalent to  $Y-51.5 = Z$  dBuA/m, which has the same margin, W dB, to the corresponding RSS-GEN Table 6 limit as it has to be 15.209(a) limit.

Below 1 GHz and above 30 MHz

The setting of the spectrum analyzer

RBW	120 kHz
VBW	300 kHz
Sweep	Auto
Detector	Peak/QP
Trace	Max hold

1. The testing follows the guidelines in ANSI C63.10-2013 clause 6.5.
2. The EUT was arranged to its worst case and then tune the antenna tower (from 1 m to 4 m) and turntable (from 0 degree to 360 degrees) to find the maximum reading. A pre-amp and a high pass filter are used for the test in order to get better signal level. Both horizontal and vertical polarizations of the antenna are set to make the measurement.
3. The EUT was placed on a turntable with 80 cm above ground.
4. The EUT was set 3 meters from the interference receiving antenna, which was mounted on the top of a variable height antenna tower.
5. For measurement below 1 GHz, the initial step in collecting conducted emission data is a spectrum analyzer peak detector mode pre-scanning the measurement frequency range. Significant peaks are then marked and then Quasi Peak detector mode re-measured. If the emission level of the EUT measured by the peak detector is 3 dB lower than the applicable limit, the peak emission level will be reported. Otherwise, the emission measurement will be repeated using the quasi-peak detector and reported.

Above 1 GHz

The setting of the spectrum analyzer

RBW	1 MHz
VBW	PEAK: 3 MHz AVG: see note 6
Sweep	Auto
Detector	Peak
Trace	Max hold

1. The testing follows the guidelines in KDB 789033 D02 General U-NII Test Procedures New Rules v02r01 section II.G.3 ~ II.G.6.
2. The EUT was arranged to its worst case and then tune the antenna tower (from 1 m to 4 m) and turntable (from 0 degree to 360 degrees) to find the maximum reading. A pre-amp and a high pass filter are used for the test in order to get better signal level. Both horizontal and vertical polarizations of the antenna are set to make the measurement.
3. The EUT was placed on a turntable with 1.5 m above ground.
4. The EUT was set 3 meters from the interference receiving antenna, which was mounted on the top of a variable height antenna tower.
5. For measurement above 1 GHz, the emission measurement will be measured by the peak detector. This peak level, once corrected, must comply with the limit specified in Section 15.209.
6. For measurements above 1 GHz the resolution bandwidth is set to 1 MHz, then the video bandwidth is set to 3 MHz for peak measurements and 1 MHz resolution bandwidth with 1/T video bandwidth with peak detector for average measurements. For the Duty Cycle please refer to clause 7.1. ON TIME AND DUTY CYCLE.

X axis, Y axis, Z axis positions:

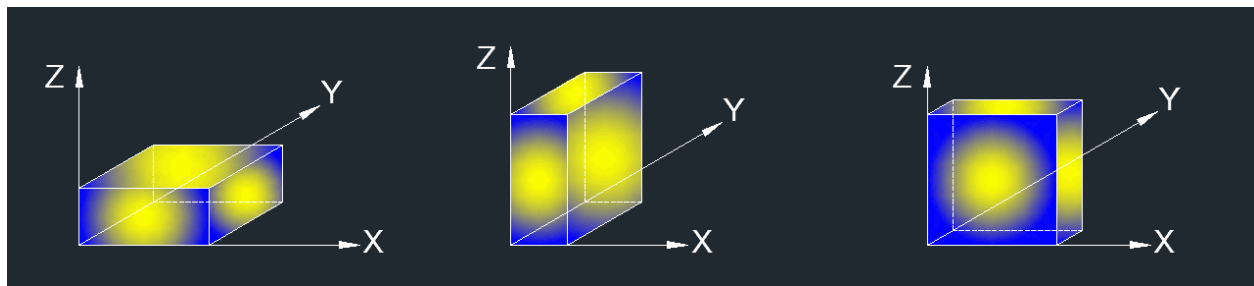

Note 1: For all radiated test, EUT in each of three orthogonal axis emissions had been tested, but only the worst case (X axis) data recorded in the report.

For Restricted Bandedge:

Note:

1. Measurement = Reading Level + Correct Factor.
2. If the peak values are less than the average limit of 54 dBuV/m, the average result is deemed to comply with average limit.
3. PK=Peak: Peak detector.
4. AV=Average: VBW=1/Ton, where: Ton is the transmitting duration.
5. For the transmitting duration, please refer to clause 7.1.
6. Only the worst data was recorded, if it complies with the limit, the other emissions deemed to comply with the limit.
7. Both horizontal and vertical have been tested, only the worst data was recorded in the report.
8. All modes have been tested, but only the worst data was recorded in the report.

For Radiate Spurious emission (9 kHz ~ 30 MHz):

Note:

1. Measurement = Reading Level + Correct Factor.
2. If the peak values are less than the QP limit, the QP result is deemed to comply with QP limit.
3. All 3 polarizations (Horizontal, Face-on and Face-off) of the loop antenna had been tested, but only the worst data recorded in the report.
4. All modes have been tested, but only the worst data was recorded in the report.
5. dBuA/m= dBuV/m- 20Log10[120π] = dBuV/m- 51.5

For Radiate Spurious Emission (30 MHz ~ 1 GHz):

Note:

1. Result Level = Read Level + Correct Factor.
2. If the peak values are less than the QP limit, the QP result is deemed to comply with QP limit.
3. All modes have been tested, but only the worst data was recorded in the report.

For Radiate Spurious Emission (1 GHz ~ 7 GHz):

1. Measurement = Reading Level + Correct Factor.
2. If the peak values are less than the average limit of 54 dBuV/m, the average result is deemed to comply with average limit.
3. Peak: Peak detector.
4. AVG: VBW=1/Ton, where: Ton is the transmitting duration.
5. For the transmitting duration, please refer to clause 7.1.
6. Filter losses were only considered in the spurious frequency bands and the authorized band was not corrected for Band reject filter losses.
7. Proper operation of the transmitter prior to adding the filter to the measurement chain.
8. Since non-restricted band peak emissions are less than the average limit, they also comply with the -27 dBm/MHz (68.2 dBuV/m) limit.
9. All modes have been tested, but only the worst data was recorded in the report.

For Radiate Spurious Emission (7 GHz ~ 18 GHz):

Note:

1. Peak Result = Reading Level + Correct Factor.
2. If the peak values are less than the average limit of 54 dBuV/m, the average result is deemed to comply with average limit.
3. Peak: Peak detector.
4. AVG:  $VBW=1/T_{on}$ , where:  $T_{on}$  is the transmitting duration.
5. For the transmitting duration, please refer to clause 7.1.
6. Filter losses were only considered in the spurious frequency bands and the authorized band was not corrected for High Pass Filter losses.
7. Proper operation of the transmitter prior to adding the filter to the measurement chain.
8. Since non-restricted band peak emissions are less than the average limit, they also comply with the -27 dBm/MHz (68.2 dBuV/m) limit.
9. All modes have been tested, but only the worst data was recorded in the report.

For Radiate Spurious emission (18 GHz ~ 26 GHz):

Note:

1. Measurement = Reading Level + Correct Factor.
2. If the peak values are less than the average limit of 54 dBuV/m, the average result is deemed to comply with average limit.
3. Peak: Peak detector.
4. All modes have been tested, but only the worst data was recorded in the report.

For Radiate Spurious emission (26 GHz ~ 40 GHz):

Note:

1. Measurement = Reading Level + Correct Factor.
2. If the peak values are less than the average limit of 54 dBuV/m, the average result is deemed to comply with average limit.
3. Peak: Peak detector.
4. All modes have been tested, but only the worst data was recorded in the report.

### TEST SETUP

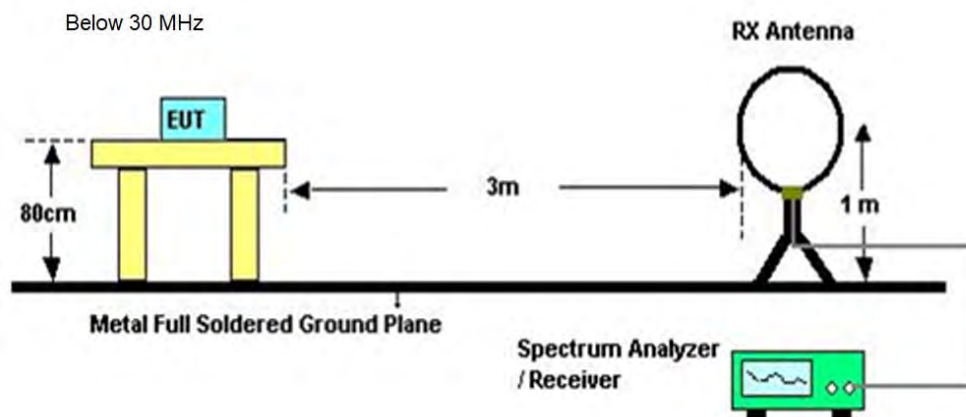

Below 1 GHz and above 30 MHz

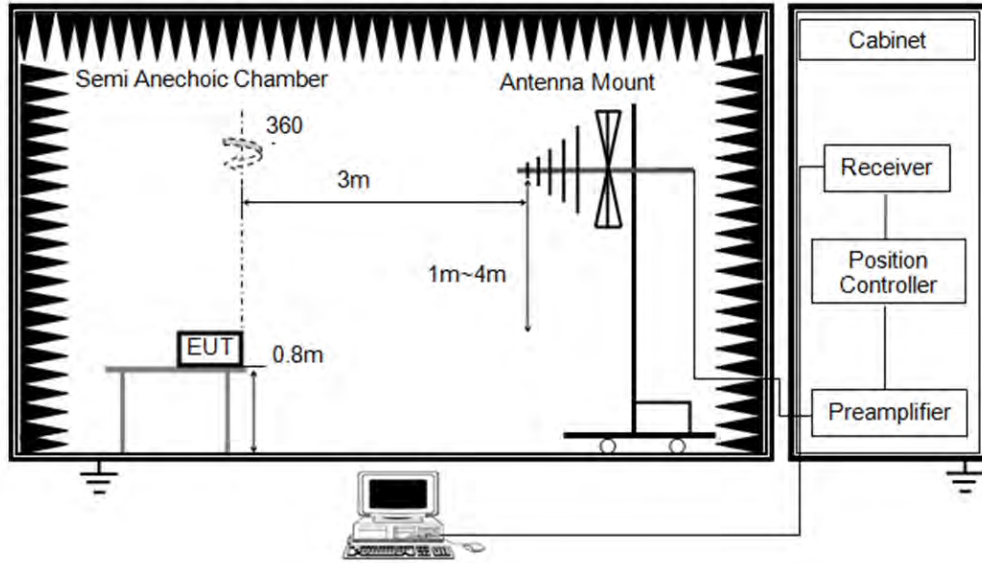

Above 1GHz

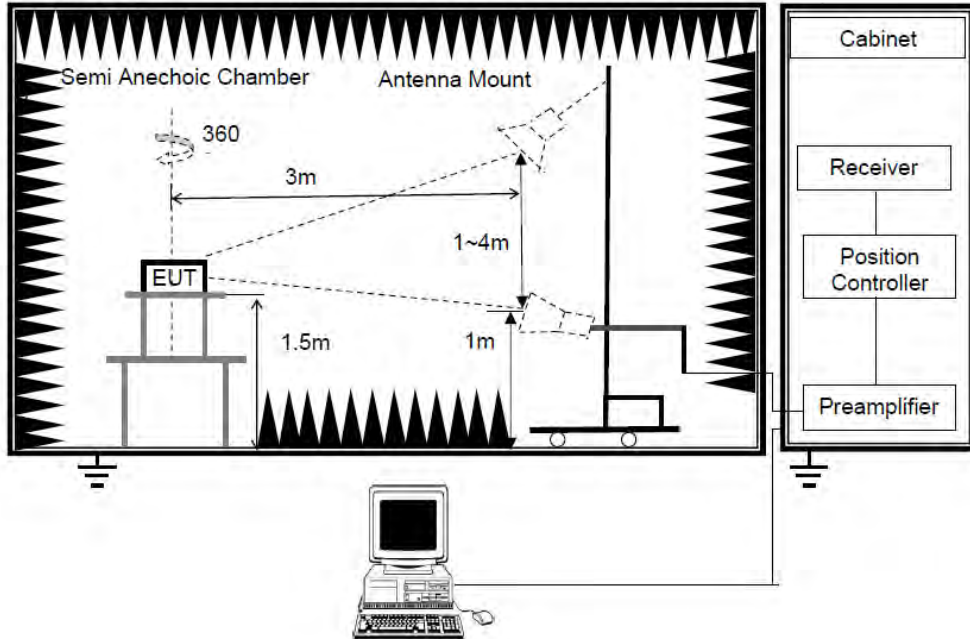

**TEST ENVIRONMENT**

Temperature	21.6°C	Relative Humidity	57.5%
Atmosphere Pressure	101kPa	Test Voltage	

**TEST DATE / ENGINEER**

Test Date	June 17, 2025	Test By	Mason Wang
-----------	---------------	---------	------------



**TEST RESULTS**

**8.1. RESTRICTED BANDEDGE**

Test Mode:	802.11a 20 PK	Frequency(MHz):	5180
Polarity:	Horizontal	Test Voltage:	AC 120V_60Hz

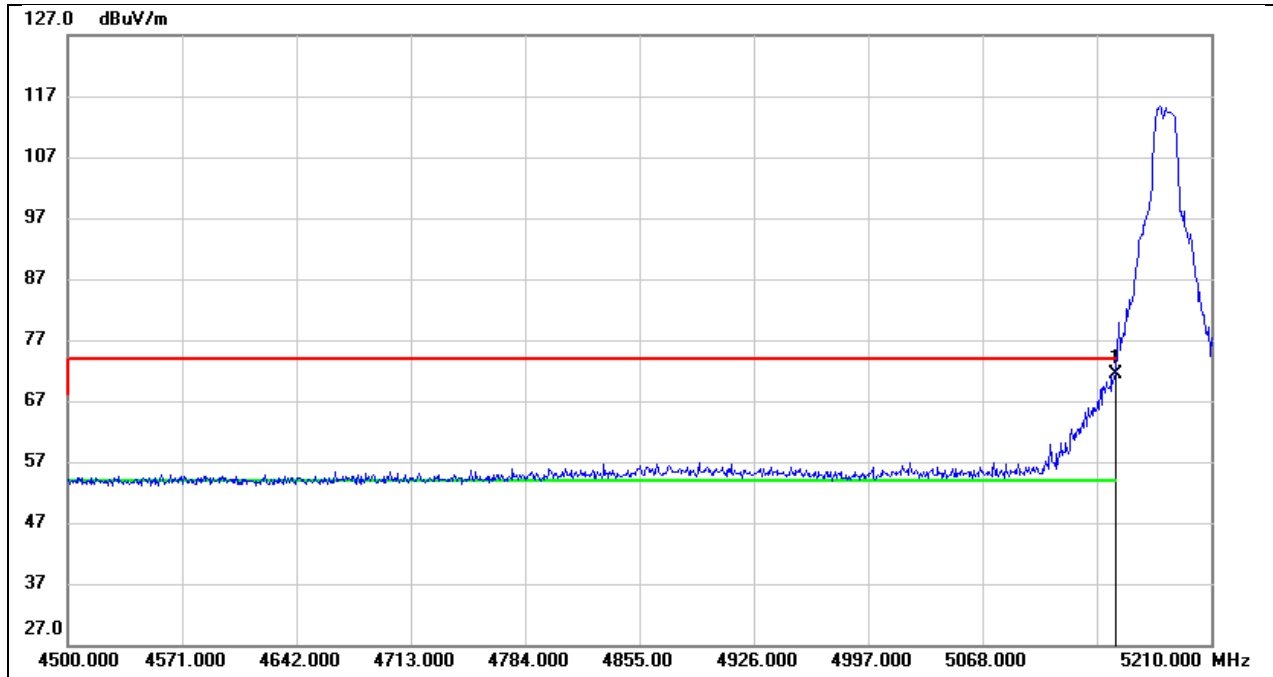

No.	Frequency (MHz)	Reading (dBuV)	Correct (dB/m)	Result (dBuV/m)	Limit (dBuV/m)	Margin (dB)	Remark
1	5150.000	32.48	38.84	71.32	74.00	-2.68	peak



Test Mode:	802.11a 20 AV	Frequency(MHz):	5180
Polarity:	Horizontal	Test Voltage:	AC 120V_60Hz

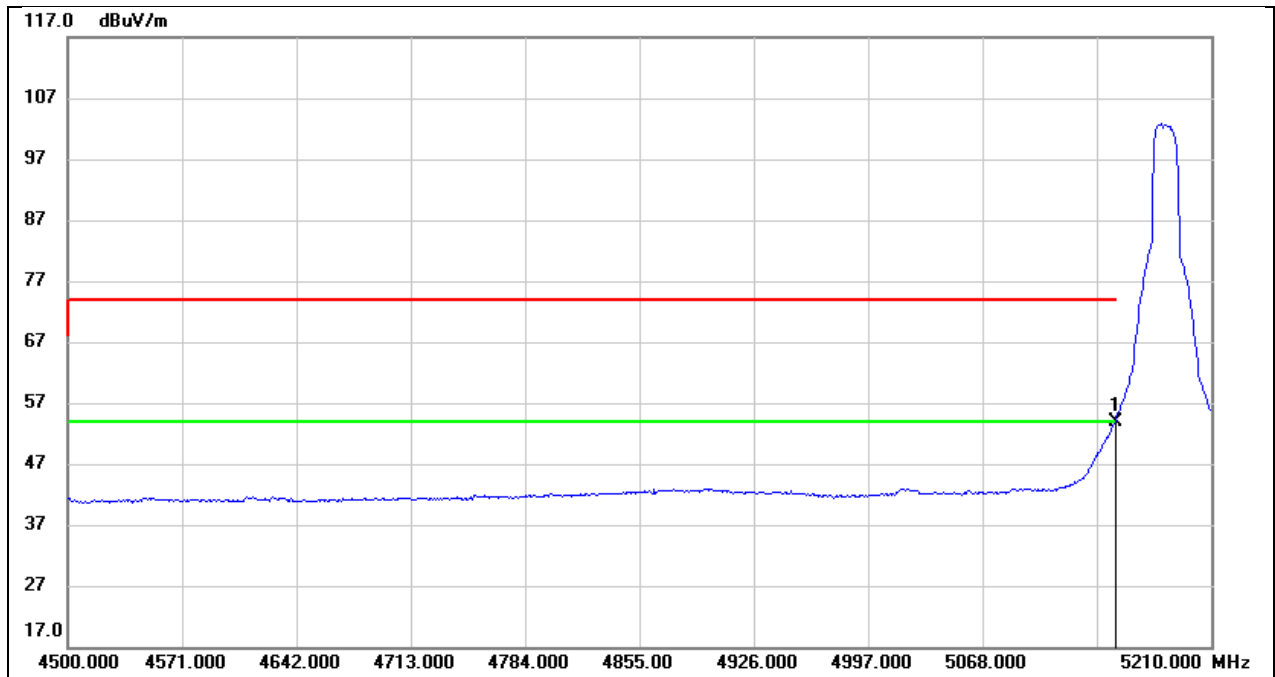

No.	Frequency (MHz)	Reading (dBuV)	Correct (dB/m)	Result (dBuV/m)	Limit (dBuV/m)	Margin (dB)	Remark
1	5150.000	15.09	38.84	53.93	54.00	-0.07	AVG

Test Mode:	802.11a 20 PK	Frequency(MHz):	5180
Polarity:	Vertical	Test Voltage:	AC 120V_60Hz

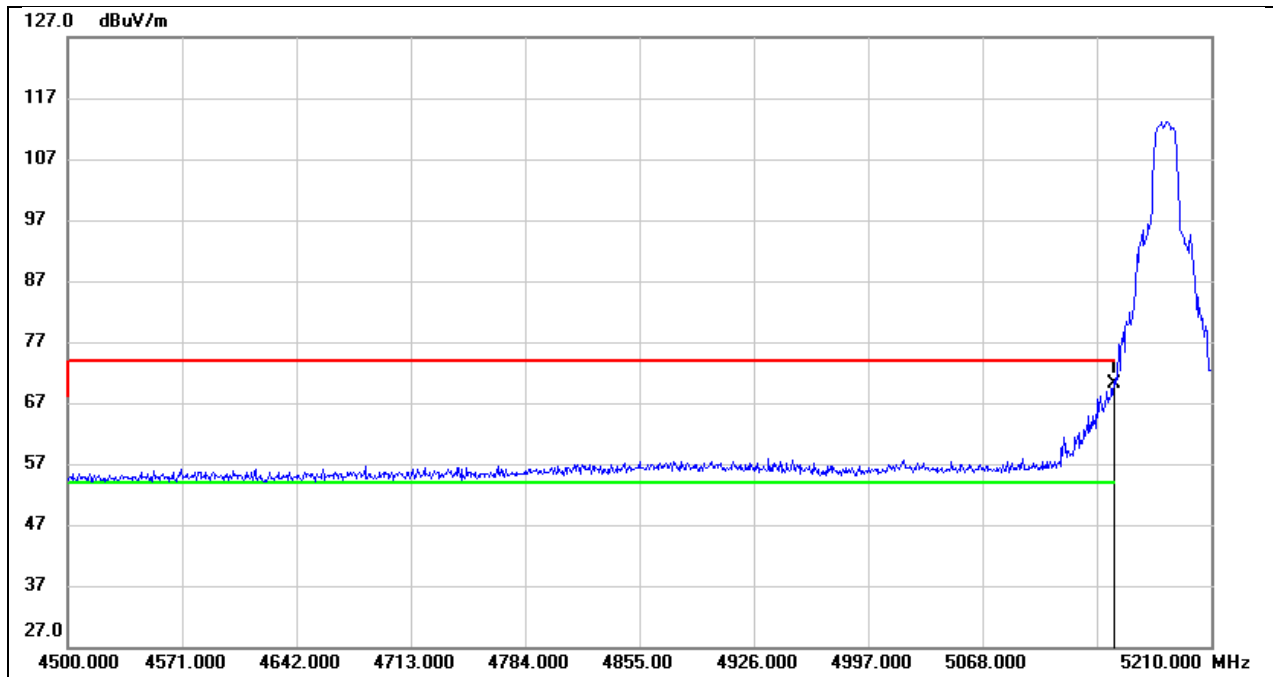

No.	Frequency (MHz)	Reading (dBuV)	Correct (dB/m)	Result (dBuV/m)	Limit (dBuV/m)	Margin (dB)	Remark
1	5150.000	30.10	40.04	70.14	74.00	-3.86	peak

Test Mode:	802.11a 20 AV	Frequency(MHz):	5180
Polarity:	Vertical	Test Voltage:	AC 120V_60Hz

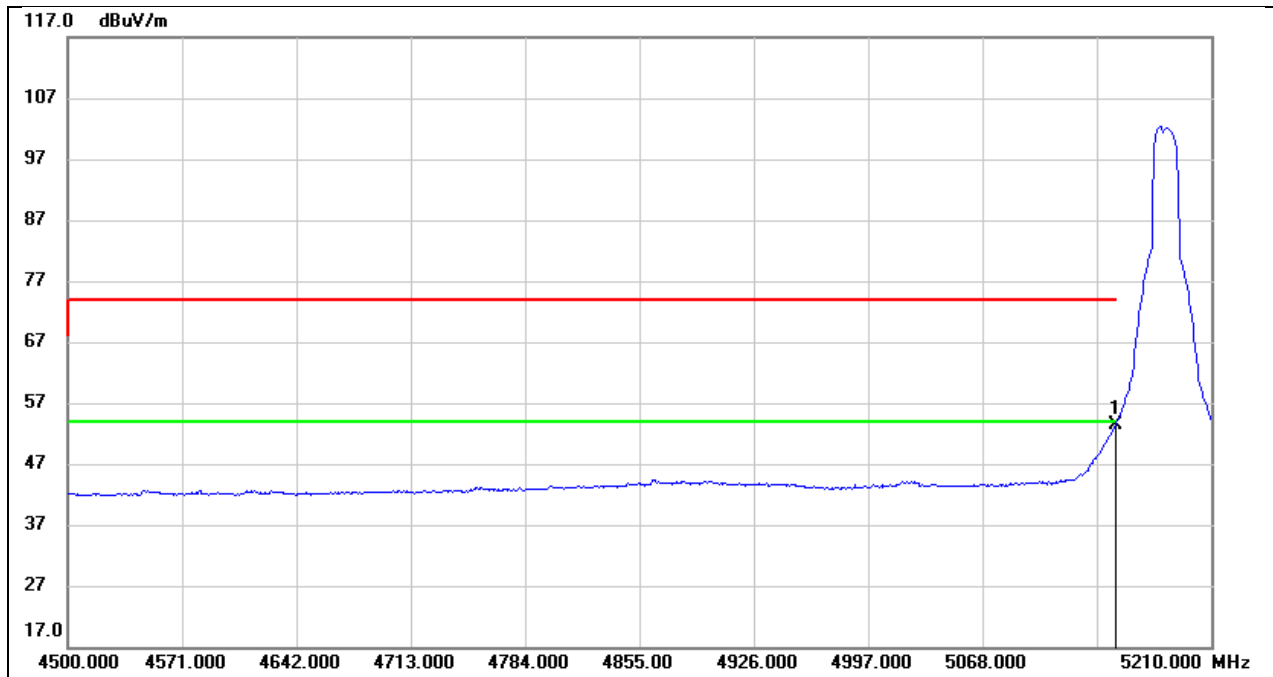

No.	Frequency (MHz)	Reading (dBuV)	Correct (dB/m)	Result (dBuV/m)	Limit (dBuV/m)	Margin (dB)	Remark
1	5150.000	13.30	40.04	53.34	54.00	-0.66	AVG

Test Mode:	802.11a 20 PK	Frequency(MHz):	5200
Polarity:	Horizontal	Test Voltage:	AC 120V_60Hz

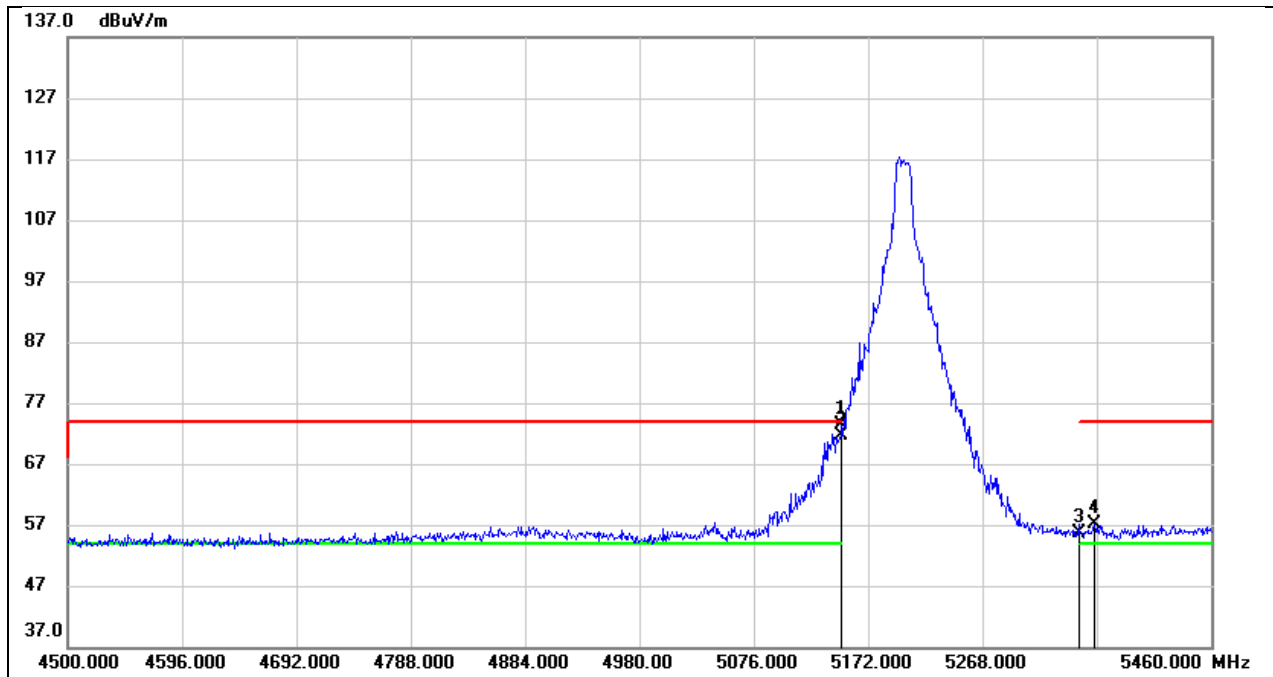

No.	Frequency (MHz)	Reading (dBuV)	Correct (dB/m)	Result (dBuV/m)	Limit (dBuV/m)	Margin (dB)	Remark
1	5149.920	34.53	38.88	73.41	74.00	-0.59	peak
2	5150.000	32.86	38.88	71.74	74.00	-2.26	peak
3	5350.000	16.36	39.25	55.61	74.00	-18.39	peak
4	5362.080	17.73	39.28	57.01	74.00	-16.99	peak

Test Mode:	802.11a 20 AV	Frequency(MHz):	5200
Polarity:	Horizontal	Test Voltage:	AC 120V_60Hz

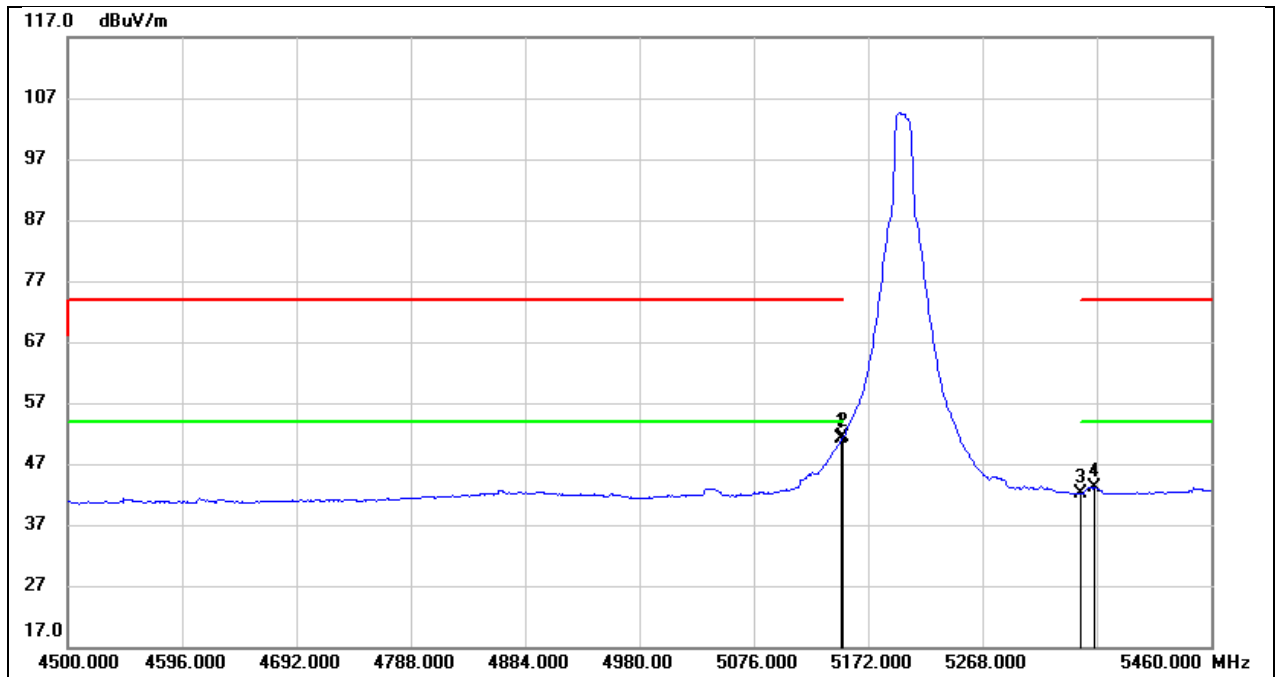

No.	Frequency (MHz)	Reading (dBuV)	Correct (dB/m)	Result (dBuV/m)	Limit (dBuV/m)	Margin (dB)	Remark
1	5149.920	12.19	38.88	51.07	54.00	-2.93	AVG
2	5150.000	12.49	38.88	51.37	54.00	-2.63	AVG
3	5350.000	2.82	39.25	42.07	54.00	-11.93	AVG
4	5362.080	3.75	39.28	43.03	54.00	-10.97	AVG

Test Mode:	802.11a 20 PK	Frequency(MHz):	5240
Polarity:	Horizontal	Test Voltage:	AC 120V_60Hz

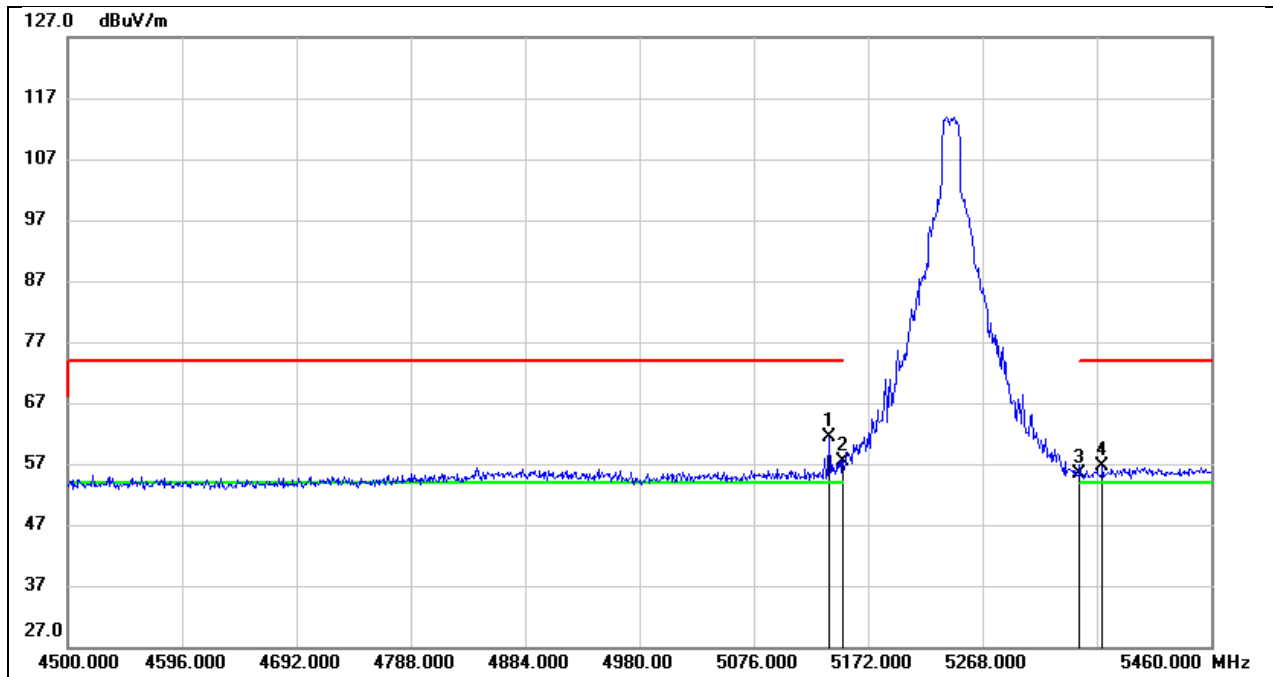

No.	Frequency (MHz)	Reading (dBuV)	Correct (dB/m)	Result (dBuV/m)	Limit (dBuV/m)	Margin (dB)	Remark
1	5139.360	22.65	38.83	61.48	74.00	-12.52	peak
2	5150.000	18.64	38.84	57.48	74.00	-16.52	peak
3	5350.000	15.97	39.29	55.26	74.00	-18.74	peak
4	5368.800	17.17	39.34	56.51	74.00	-17.49	peak

Test Mode:	802.11a 20 AV	Frequency(MHz):	5240
Polarity:	Horizontal	Test Voltage:	AC 120V_60Hz

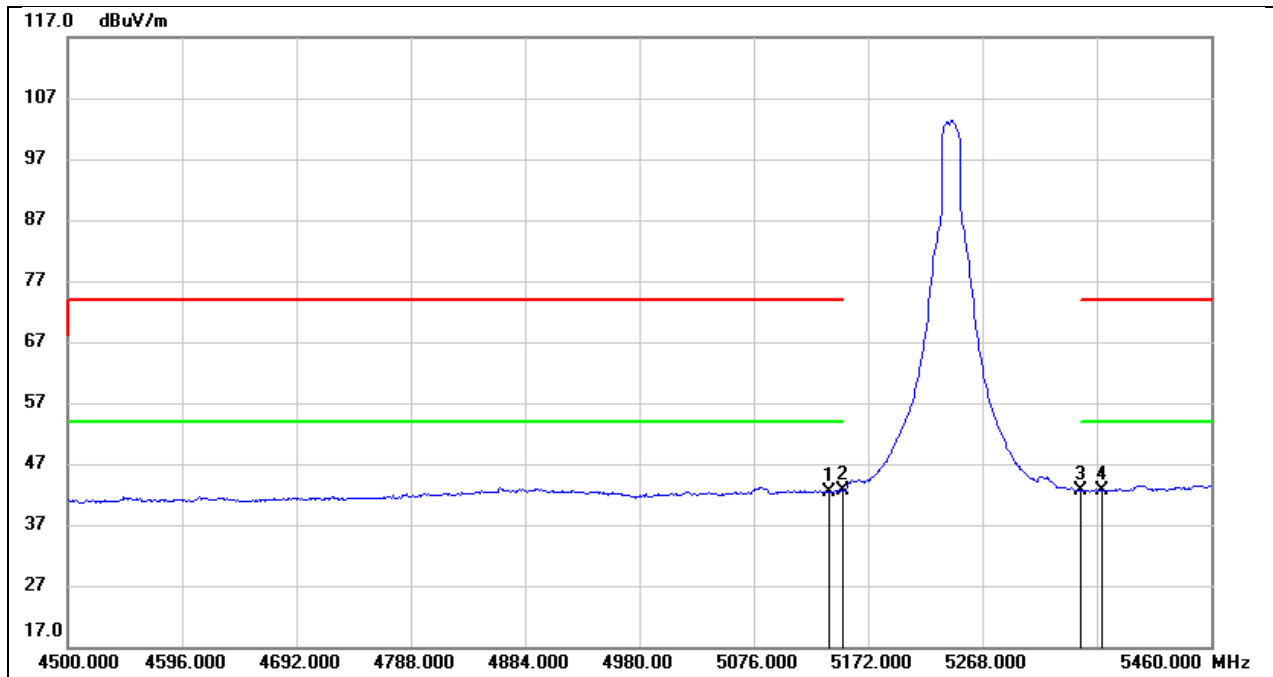

No.	Frequency (MHz)	Reading (dBuV)	Correct (dB/m)	Result (dBuV/m)	Limit (dBuV/m)	Margin (dB)	Remark
1	5139.360	3.63	38.83	42.46	54.00	-11.54	AVG
2	5150.000	3.78	38.84	42.62	54.00	-11.38	AVG
3	5350.000	3.34	39.29	42.63	54.00	-11.37	AVG
4	5368.800	3.26	39.34	42.60	54.00	-11.40	AVG

Test Mode:	802.11a 20 PK	Frequency(MHz):	5260
Polarity:	Horizontal	Test Voltage:	AC 120V_60Hz

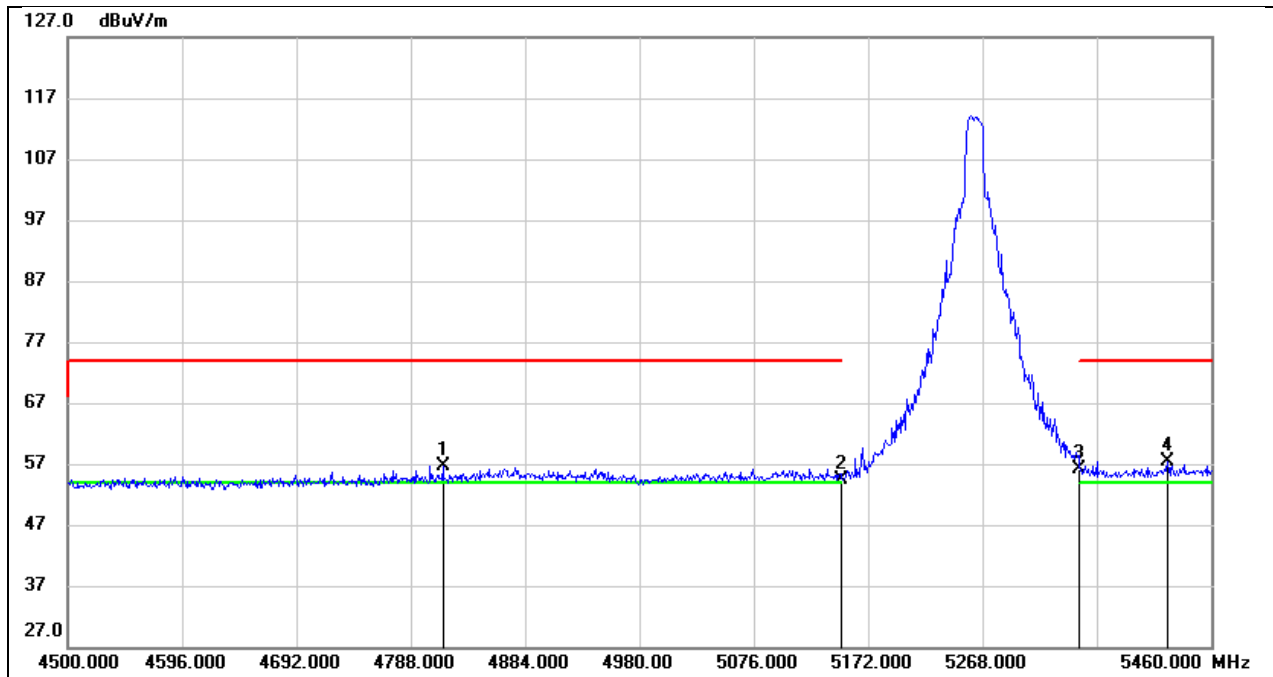

No.	Frequency (MHz)	Reading (dBuV)	Correct (dB/m)	Result (dBuV/m)	Limit (dBuV/m)	Margin (dB)	Remark
1	4814.880	18.47	38.23	56.70	74.00	-17.30	peak
2	5150.000	15.62	38.84	54.46	74.00	-19.54	peak
3	5350.000	16.87	39.29	56.16	74.00	-17.84	peak
4	5423.520	17.91	39.48	57.39	74.00	-16.61	peak



Test Mode:	802.11a 20 AV	Frequency(MHz):	5260
Polarity:	Horizontal	Test Voltage:	AC 120V_60Hz

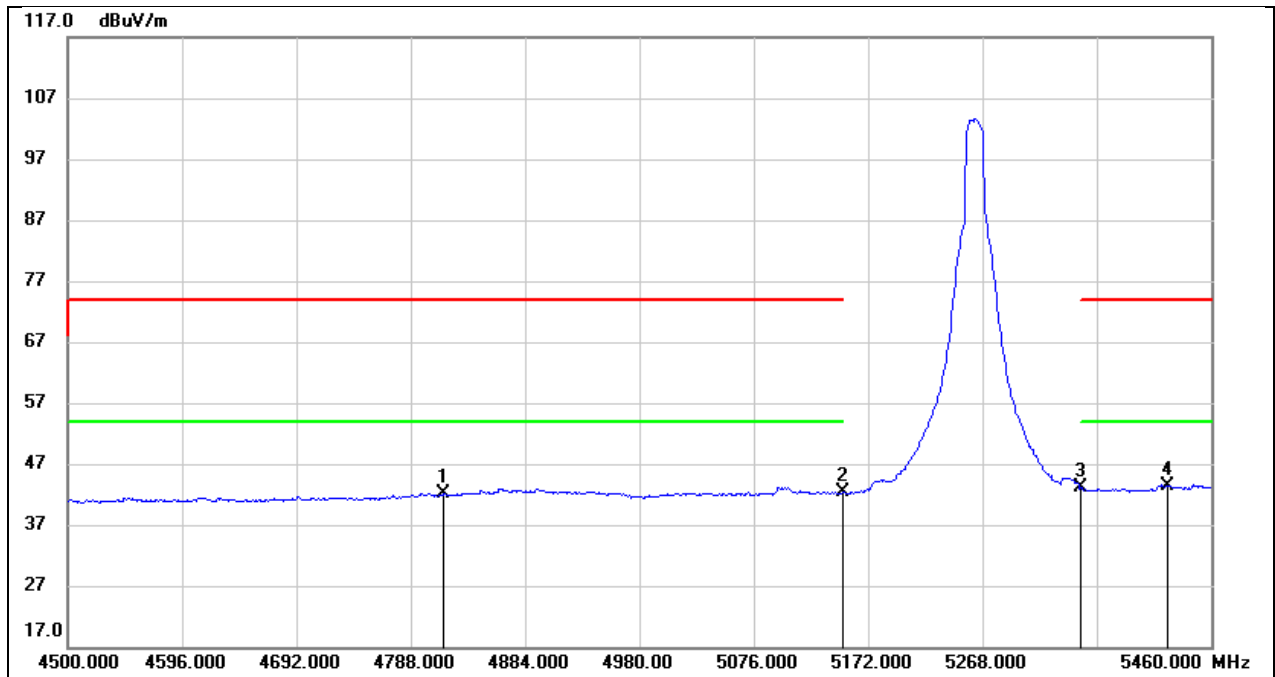

No.	Frequency (MHz)	Reading (dBuV)	Correct (dB/m)	Result (dBuV/m)	Limit (dBuV/m)	Margin (dB)	Remark
1	4814.880	3.83	38.23	42.06	54.00	-11.94	AVG
2	5150.000	3.44	38.84	42.28	54.00	-11.72	AVG
3	5350.000	3.76	39.29	43.05	54.00	-10.95	AVG
4	5423.520	3.88	39.48	43.36	54.00	-10.64	AVG

Test Mode:	802.11a 20 PK	Frequency(MHz):	5280
Polarity:	Horizontal	Test Voltage:	AC 120V_60Hz

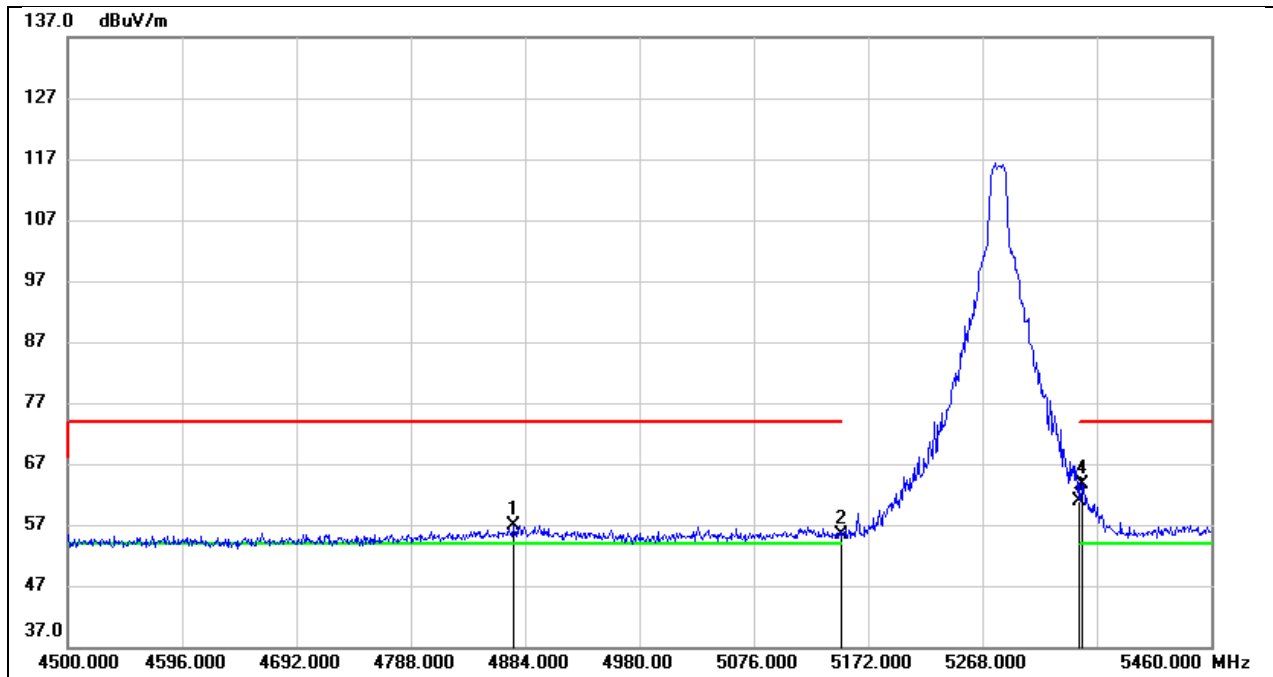

No.	Frequency (MHz)	Reading (dBuV)	Correct (dB/m)	Result (dBuV/m)	Limit (dBuV/m)	Margin (dB)	Remark
1	4874.400	18.46	38.45	56.91	74.00	-17.09	peak
2	5150.000	16.43	38.88	55.31	74.00	-18.69	peak
3	5350.000	21.74	39.25	60.99	74.00	-13.01	peak
4	5351.520	24.42	39.26	63.68	74.00	-10.32	peak

Test Mode:	802.11a 20 AV	Frequency(MHz):	5280
Polarity:	Horizontal	Test Voltage:	AC 120V_60Hz

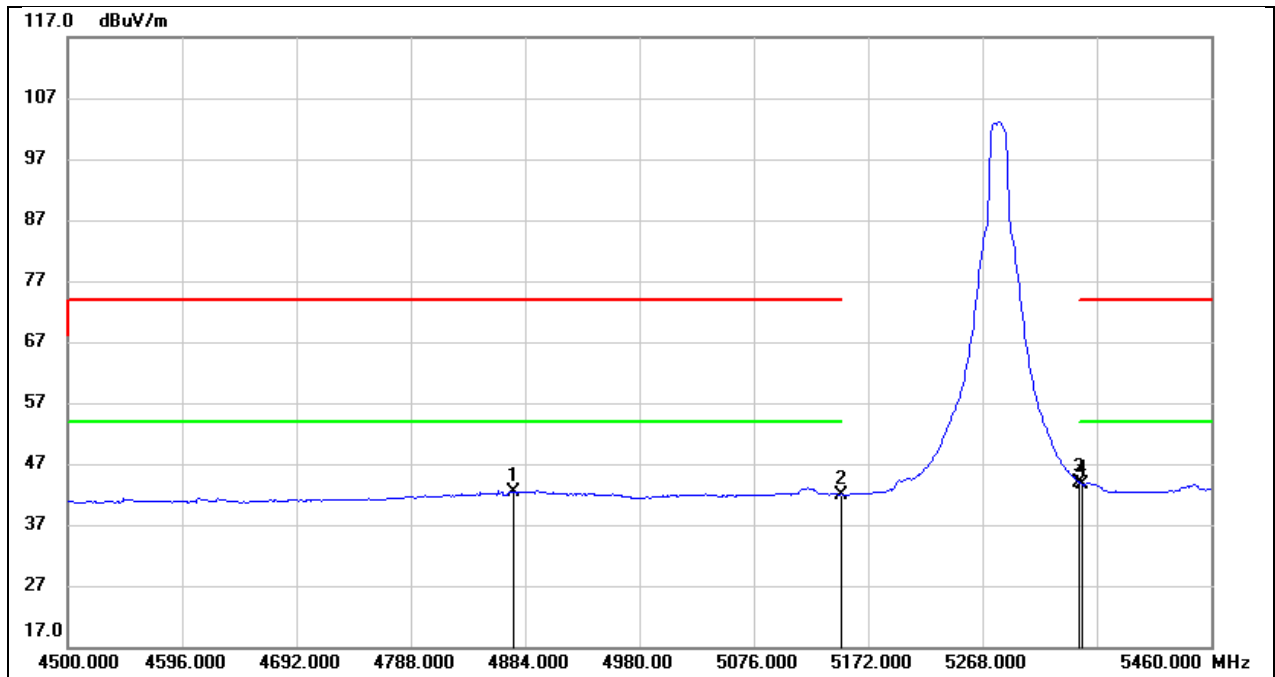

No.	Frequency (MHz)	Reading (dBuV)	Correct (dB/m)	Result (dBuV/m)	Limit (dBuV/m)	Margin (dB)	Remark
1	4874.400	3.84	38.45	42.29	54.00	-11.71	AVG
2	5150.000	3.08	38.88	41.96	54.00	-12.04	AVG
3	5350.000	4.59	39.25	43.84	54.00	-10.16	AVG
4	5351.520	4.44	39.26	43.70	54.00	-10.30	AVG

Test Mode:	802.11a 20 PK	Frequency(MHz):	5320
Polarity:	Horizontal	Test Voltage:	AC 120V_60Hz

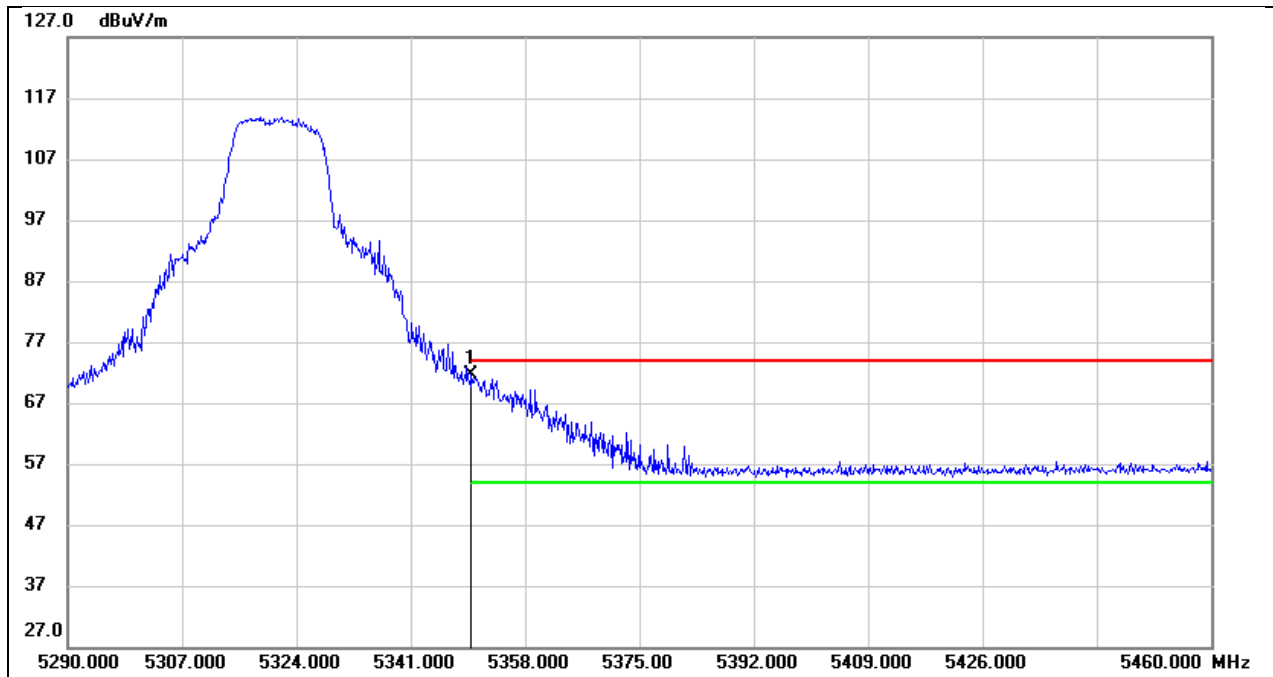

No.	Frequency (MHz)	Reading (dBuV)	Correct (dB/m)	Result (dBuV/m)	Limit (dBuV/m)	Margin (dB)	Remark
1	5350.000	32.40	39.29	71.69	74.00	-2.31	peak

Test Mode:	802.11a 20 AV	Frequency(MHz):	5320
Polarity:	Horizontal	Test Voltage:	AC 120V_60Hz

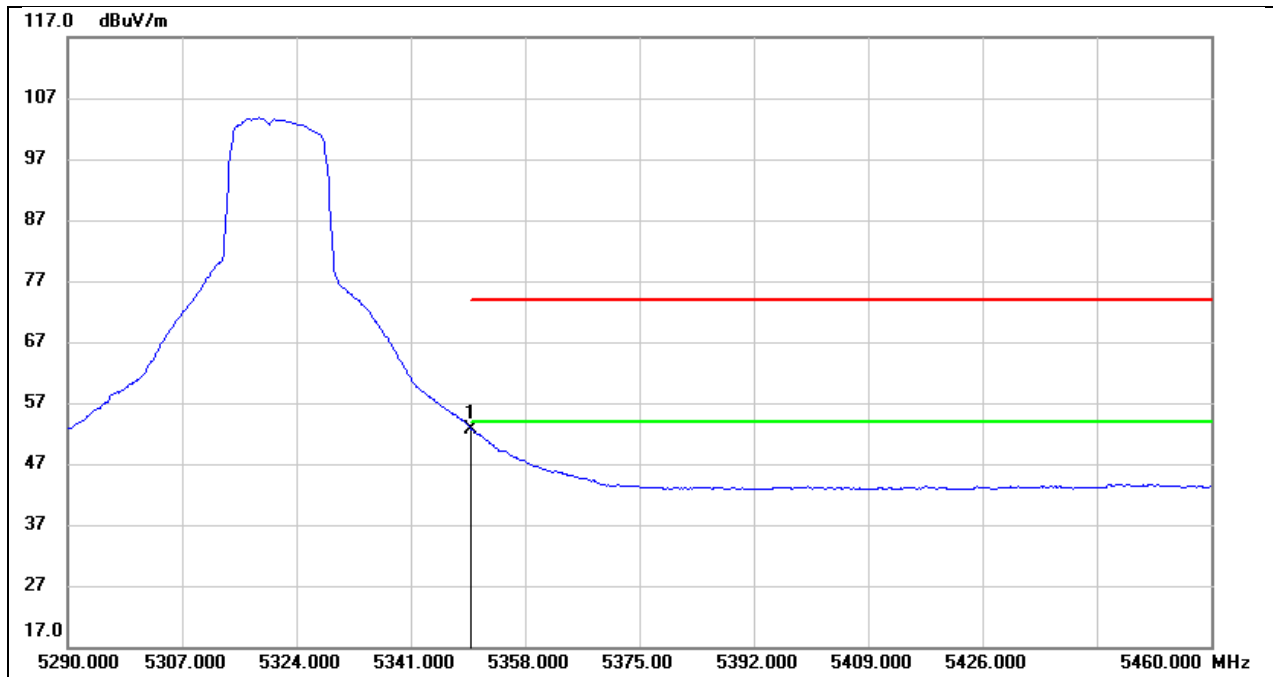

No.	Frequency (MHz)	Reading (dBuV)	Correct (dB/m)	Result (dBuV/m)	Limit (dBuV/m)	Margin (dB)	Remark
1	5350.000	13.41	39.29	52.70	54.00	-1.30	AVG

Test Mode:	802.11a 20 PK	Frequency(MHz):	5500
Polarity:	Horizontal	Test Voltage:	AC 120V_60Hz

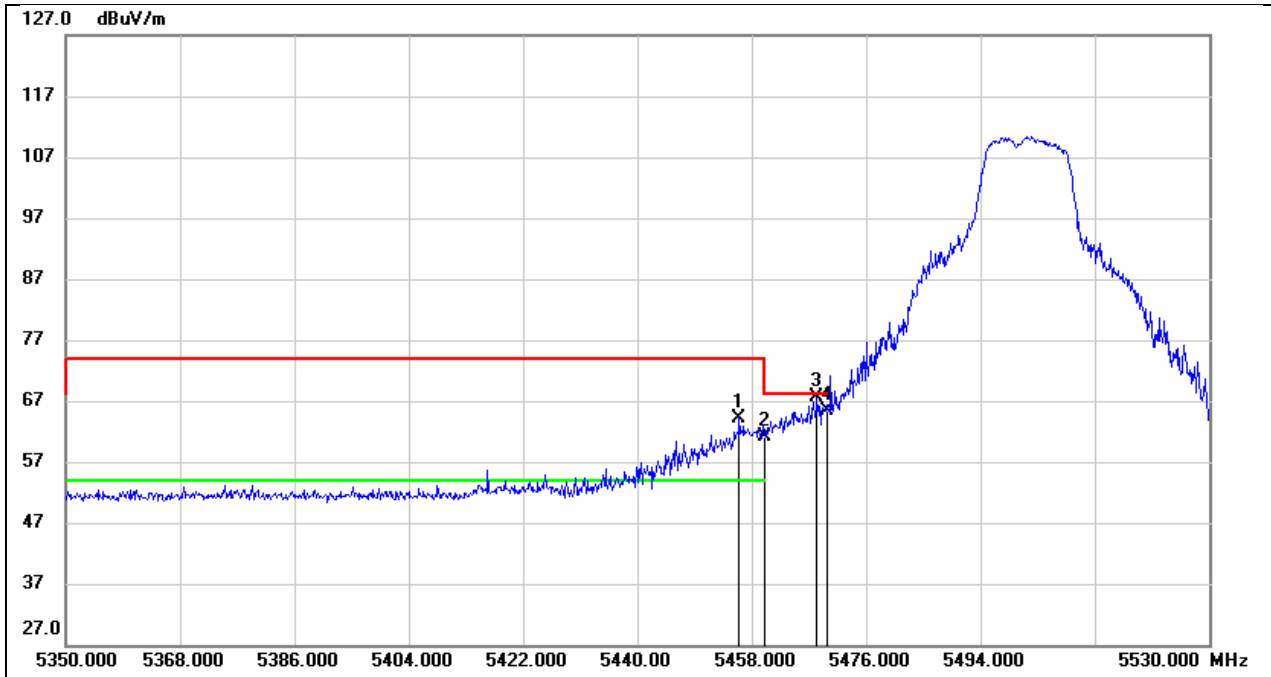

No.	Frequency (MHz)	Reading (dBuV)	Correct (dB/m)	Result (dBuV/m)	Limit (dBuV/m)	Margin (dB)	Remark
1	5456.020	30.25	34.00	64.25	74.00	-9.75	peak
2	5460.000	27.08	34.00	61.08	74.00	-12.92	peak
3	5468.260	33.68	33.99	67.67	68.20	-0.53	peak
4	5470.000	31.41	33.99	65.40	68.20	-2.80	peak

Test Mode:	802.11a 20 AV	Frequency(MHz):	5500
Polarity:	Horizontal	Test Voltage:	AC 120V_60Hz

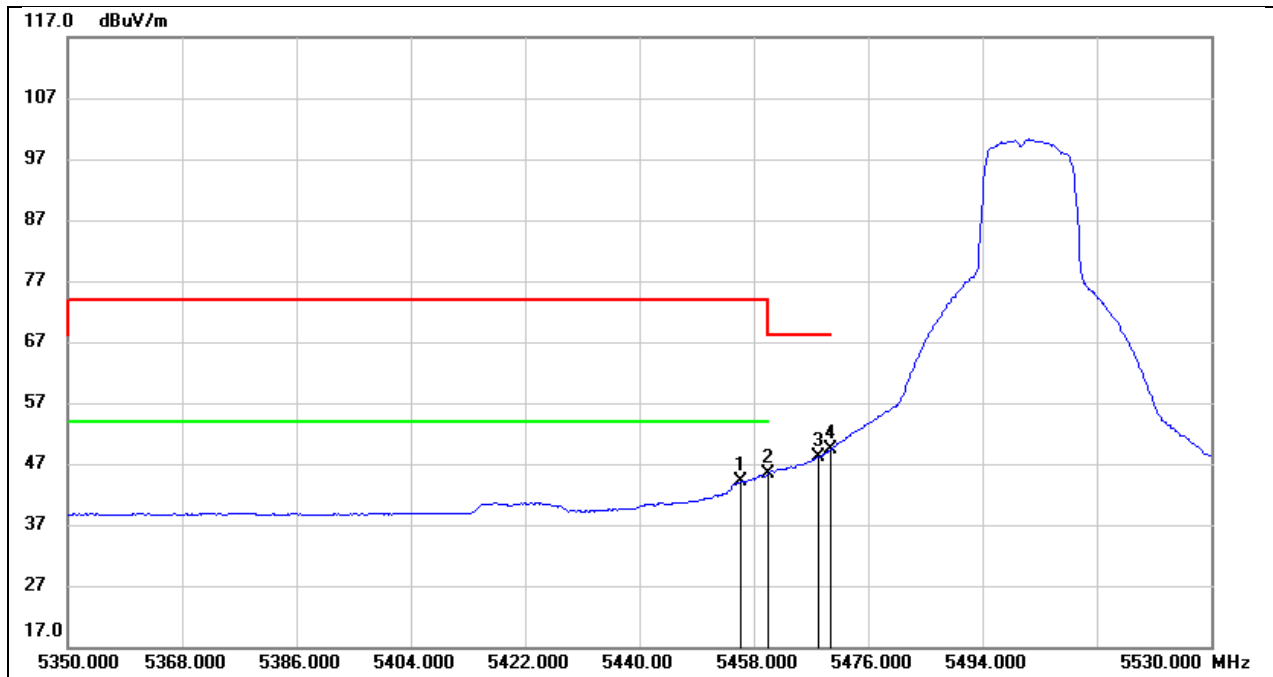

No.	Frequency (MHz)	Reading (dBuV)	Correct (dB/m)	Result (dBuV/m)	Limit (dBuV/m)	Margin (dB)	Remark
1	5456.020	10.03	34.00	44.03	54.00	-9.97	AVG
2	5460.000	11.30	34.00	45.30	54.00	-8.70	AVG
3	5468.260	14.15	33.99	48.14	/	/	AVG
4	5470.000	15.38	33.99	49.37	/	/	AVG

Test Mode:	802.11a 20 PK	Frequency(MHz):	5580
Polarity:	Horizontal	Test Voltage:	AC 120V_60Hz

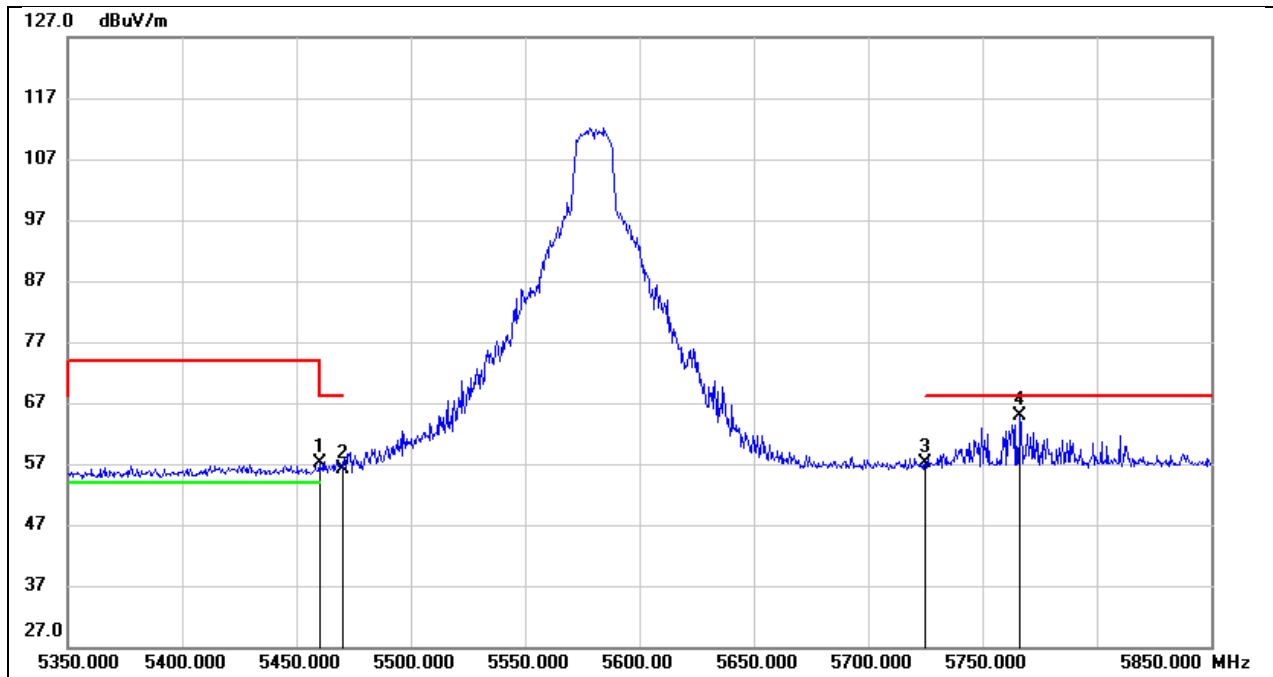

No.	Frequency (MHz)	Reading (dBuV)	Correct (dB/m)	Result (dBuV/m)	Limit (dBuV/m)	Margin (dB)	Remark
1	5460.000	17.52	39.56	57.08	74.00	-16.92	peak
2	5470.000	16.53	39.58	56.11	68.20	-12.09	peak
3	5725.000	17.05	40.09	57.14	68.20	-11.06	peak
4	5766.500	24.63	40.14	64.77	68.20	-3.43	peak



Test Mode:	802.11a 20 AV	Frequency(MHz):	5580
Polarity:	Horizontal	Test Voltage:	AC 120V_60Hz

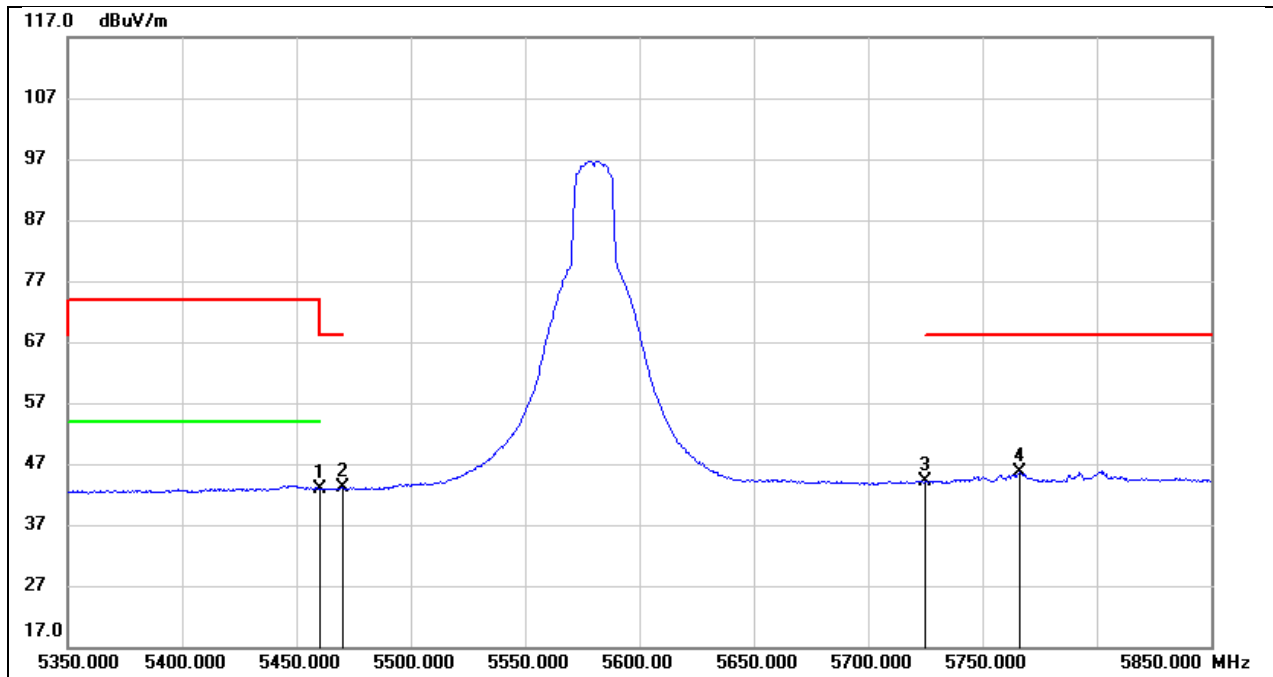

No.	Frequency (MHz)	Reading (dBuV)	Correct (dB/m)	Result (dBuV/m)	Limit (dBuV/m)	Margin (dB)	Remark
1	5460.000	3.29	39.56	42.85	54.00	-11.15	AVG
2	5470.000	3.61	39.58	43.19	/	/	AVG
3	5725.000	3.93	40.09	44.02	/	/	AVG
4	5766.500	5.49	40.14	45.63	/	/	AVG

Test Mode:	802.11a 20 PK	Frequency(MHz):	5700
Polarity:	Horizontal	Test Voltage:	DC 5V

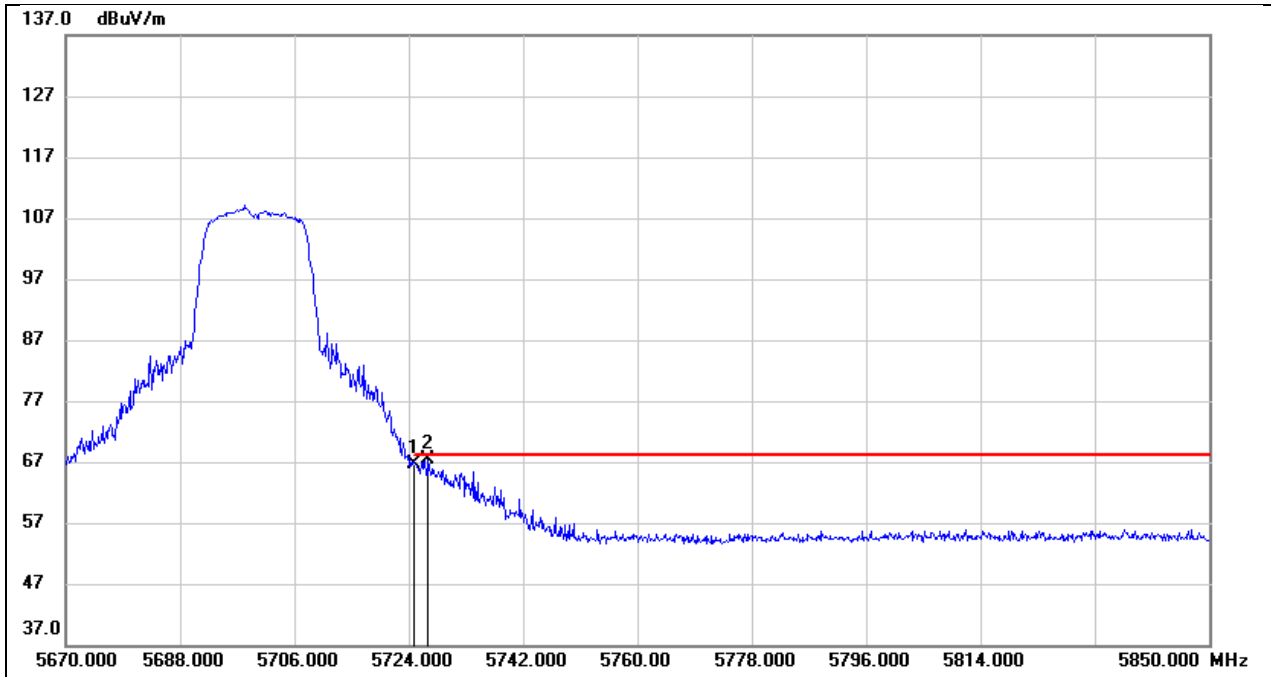

No.	Frequency (MHz)	Reading (dBuV)	Correct (dB/m)	Result (dBuV/m)	Limit (dBuV/m)	Margin (dB)	Remark
1	5725.000	31.31	35.28	66.59	68.20	-1.61	peak
2	5727.060	32.07	35.30	67.37	68.20	-0.83	peak

Test Mode:	802.11a 20 PK	Frequency(MHz):	5745
Polarity:	Horizontal	Test Voltage:	AC 120V_60Hz

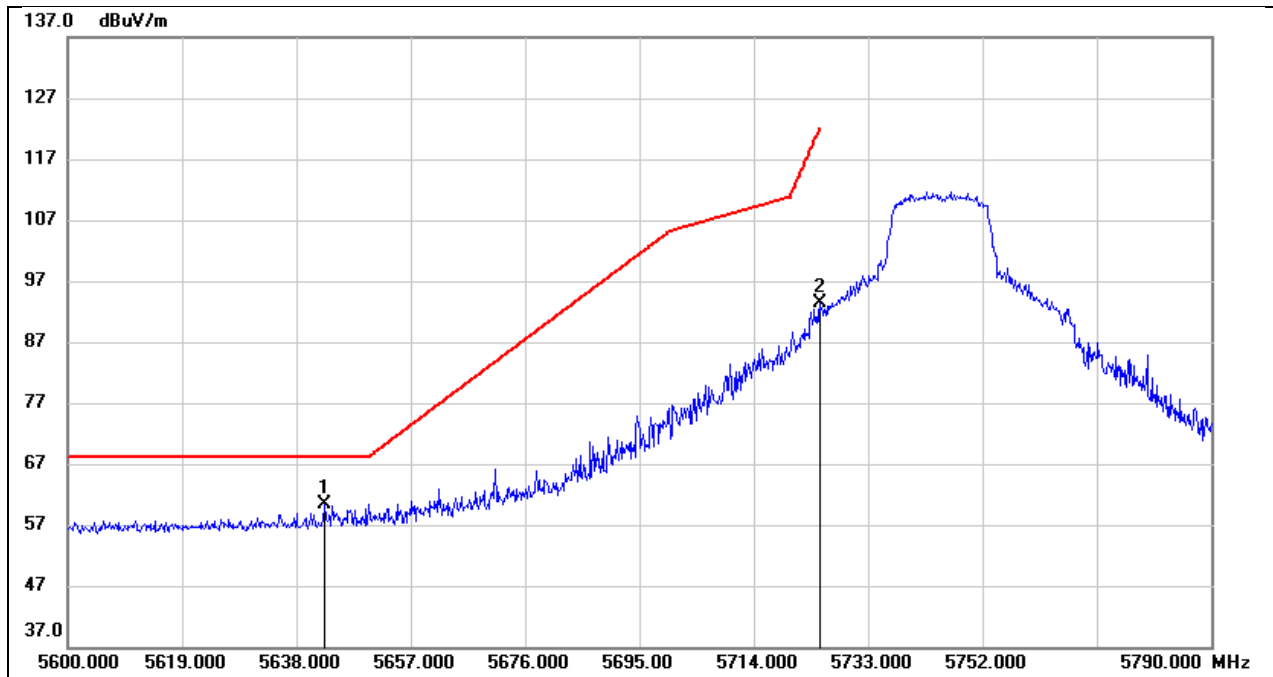

No.	Frequency (MHz)	Reading (dBuV)	Correct (dB/m)	Result (dBuV/m)	Limit (dBuV/m)	Margin (dB)	Remark
1	5642.750	20.32	39.98	60.30	68.20	-7.90	peak
2	5725.000	53.39	40.09	93.48	122.20	-28.72	peak

Test Mode:	802.11a 20 PK	Frequency(MHz):	5785
Polarity:	Horizontal	Test Voltage:	AC 120V_60Hz

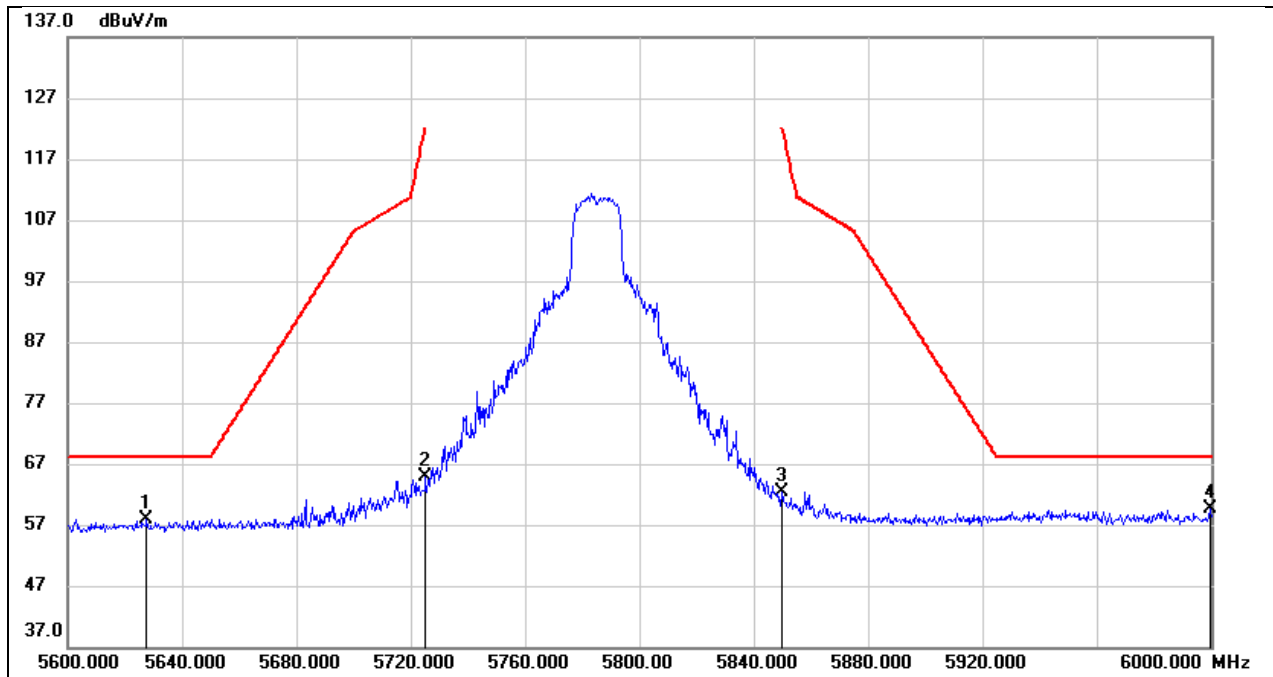

No.	Frequency (MHz)	Reading (dBuV)	Correct (dB/m)	Result (dBuV/m)	Limit (dBuV/m)	Margin (dB)	Remark
1	5627.600	18.02	39.96	57.98	68.20	-10.22	peak
2	5725.000	24.91	40.09	65.00	122.20	-57.20	peak
3	5850.000	22.00	40.30	62.30	122.20	-59.90	peak
4	5999.600	19.09	40.65	59.74	68.20	-8.46	peak

Test Mode:	802.11a 20 PK	Frequency(MHz):	5825
Polarity:	Horizontal	Test Voltage:	AC 120V_60Hz

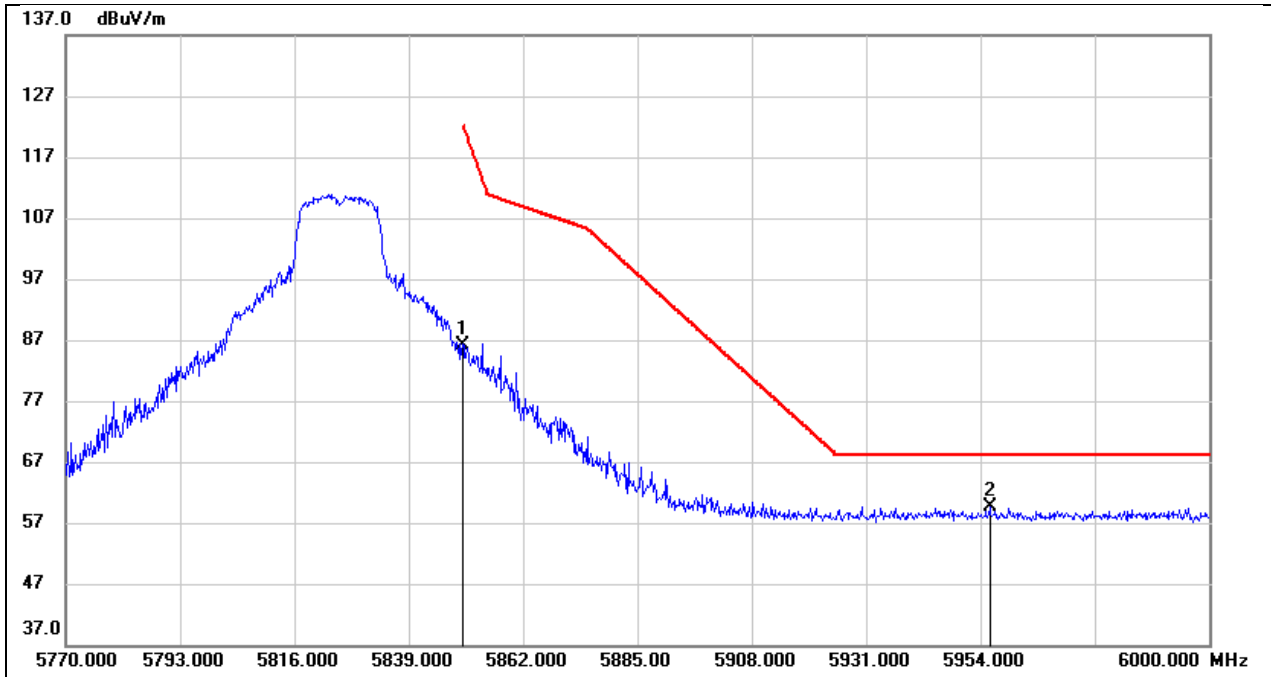

No.	Frequency (MHz)	Reading (dBuV)	Correct (dB/m)	Result (dBuV/m)	Limit (dBuV/m)	Margin (dB)	Remark
1	5850.000	45.87	40.30	86.17	122.20	-36.03	peak
2	5955.840	19.20	40.55	59.75	68.20	-8.45	peak

Test Mode:	802.11n HT20 PK	Frequency(MHz):	5180
Polarity:	Horizontal	Test Voltage:	AC 120V_60Hz

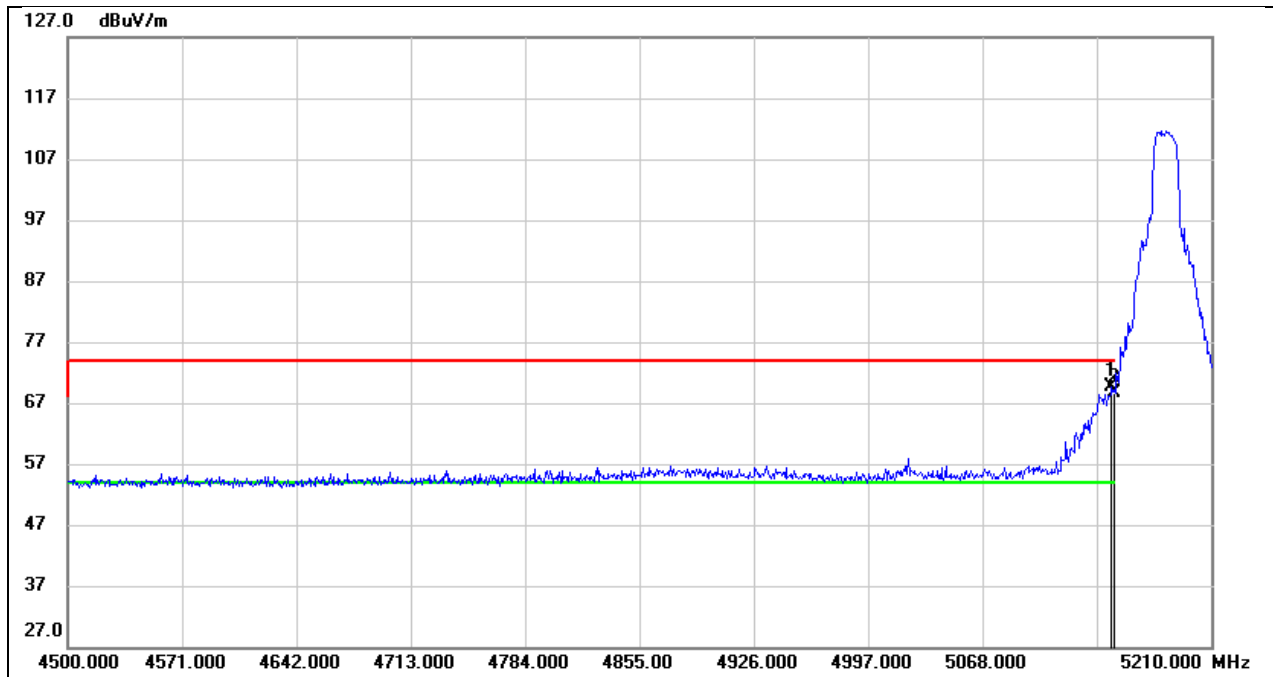

No.	Frequency (MHz)	Reading (dBuV)	Correct (dB/m)	Result (dBuV/m)	Limit (dBuV/m)	Margin (dB)	Remark
1	5148.230	30.79	38.84	69.63	74.00	-4.37	peak
2	5150.000	29.74	38.84	68.58	74.00	-5.42	peak

Test Mode:	802.11n HT20 AV	Frequency(MHz):	5180
Polarity:	Horizontal	Test Voltage:	AC 120V_60Hz

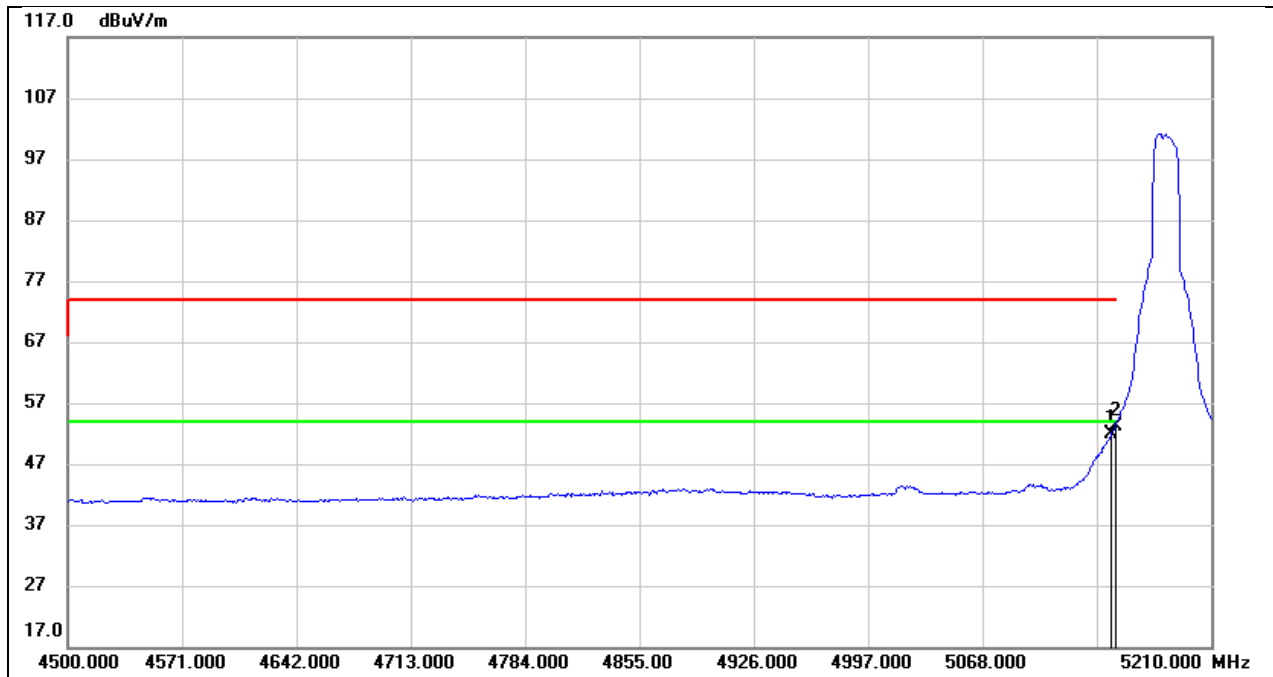

No.	Frequency (MHz)	Reading (dBuV)	Correct (dB/m)	Result (dBuV/m)	Limit (dBuV/m)	Margin (dB)	Remark
1	5148.230	13.08	38.84	51.92	54.00	-2.08	AVG
2	5150.000	14.34	38.84	53.18	54.00	-0.82	AVG

Test Mode:	802.11n HT20 PK	Frequency(MHz):	5200
Polarity:	Horizontal	Test Voltage:	AC 120V_60Hz

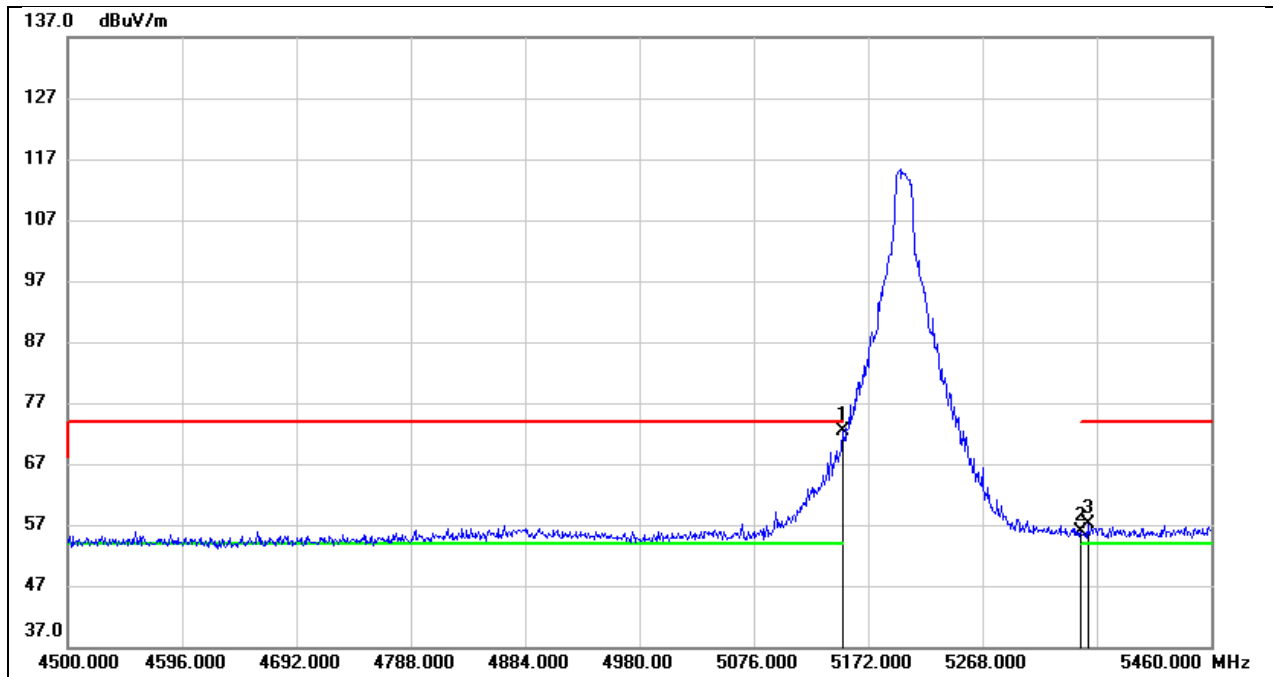

No.	Frequency (MHz)	Reading (dBuV)	Correct (dB/m)	Result (dBuV/m)	Limit (dBuV/m)	Margin (dB)	Remark
1	5150.000	33.57	38.88	72.45	74.00	-1.55	peak
2	5350.000	16.57	39.25	55.82	74.00	-18.18	peak
3	5356.320	17.80	39.26	57.06	74.00	-16.94	peak



Test Mode:	802.11n HT20 AV	Frequency(MHz):	5200
Polarity:	Horizontal	Test Voltage:	AC 120V_60Hz

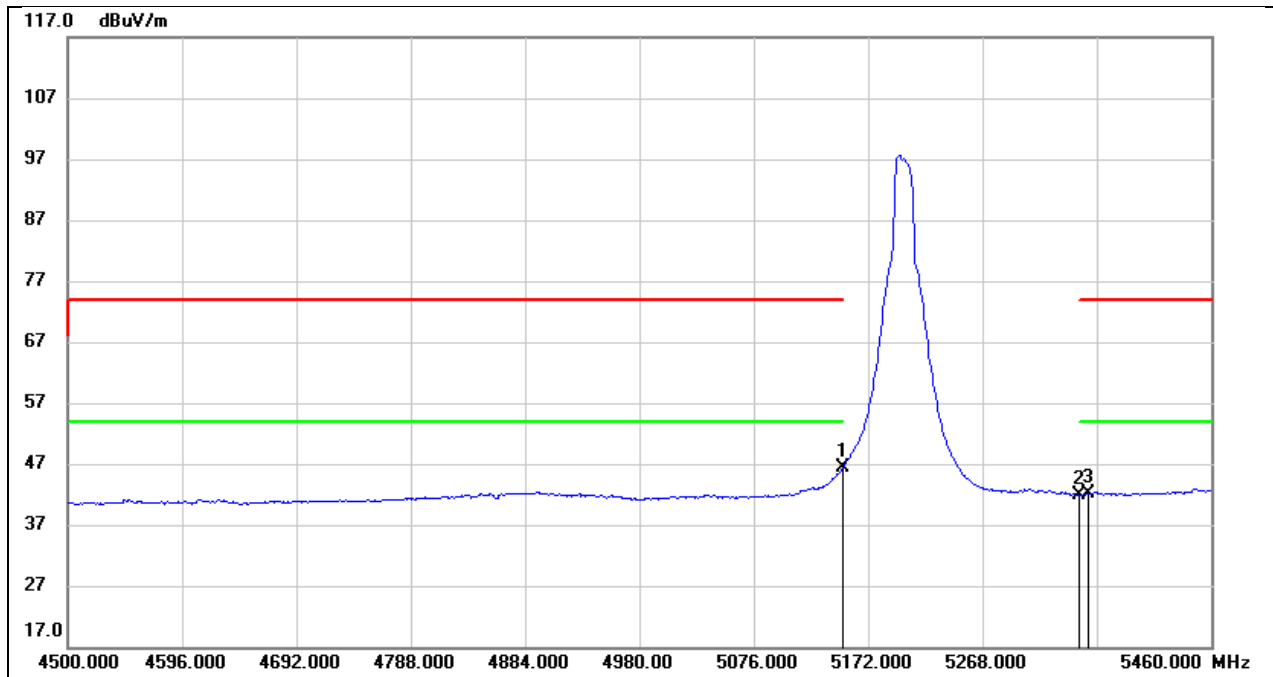

No.	Frequency (MHz)	Reading (dBuV)	Correct (dB/m)	Result (dBuV/m)	Limit (dBuV/m)	Margin (dB)	Remark
1	5150.000	7.55	38.88	46.43	54.00	-7.57	AVG
2	5350.000	2.68	39.25	41.93	54.00	-12.07	AVG
3	5356.320	2.87	39.26	42.13	54.00	-11.87	AVG

Test Mode:	802.11n HT20 PK	Frequency(MHz):	5240
Polarity:	Horizontal	Test Voltage:	AC 120V_60Hz

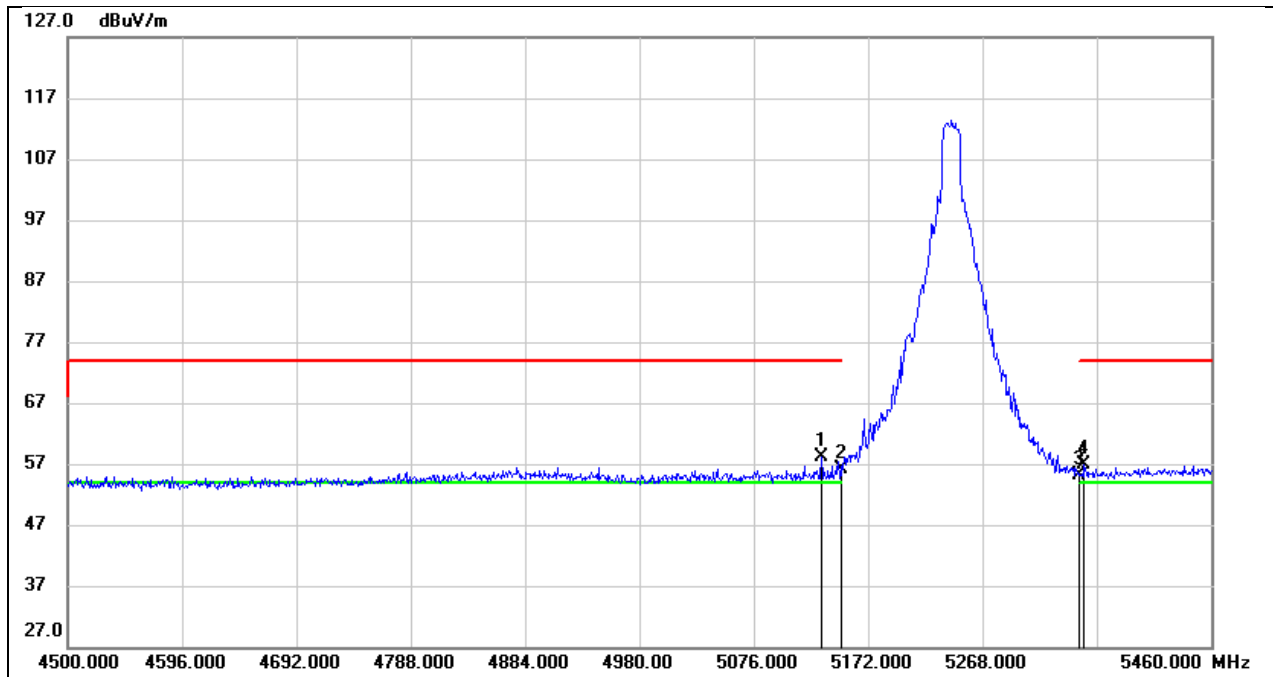

No.	Frequency (MHz)	Reading (dBuV)	Correct (dB/m)	Result (dBuV/m)	Limit (dBuV/m)	Margin (dB)	Remark
1	5132.640	19.41	38.81	58.22	74.00	-15.78	peak
2	5150.000	17.24	38.84	56.08	74.00	-17.92	peak
3	5350.000	15.93	39.29	55.22	74.00	-18.78	peak
4	5353.440	17.65	39.30	56.95	74.00	-17.05	peak

Test Mode:	802.11n HT20 AV	Frequency(MHz):	5240
Polarity:	Horizontal	Test Voltage:	AC 120V_60Hz

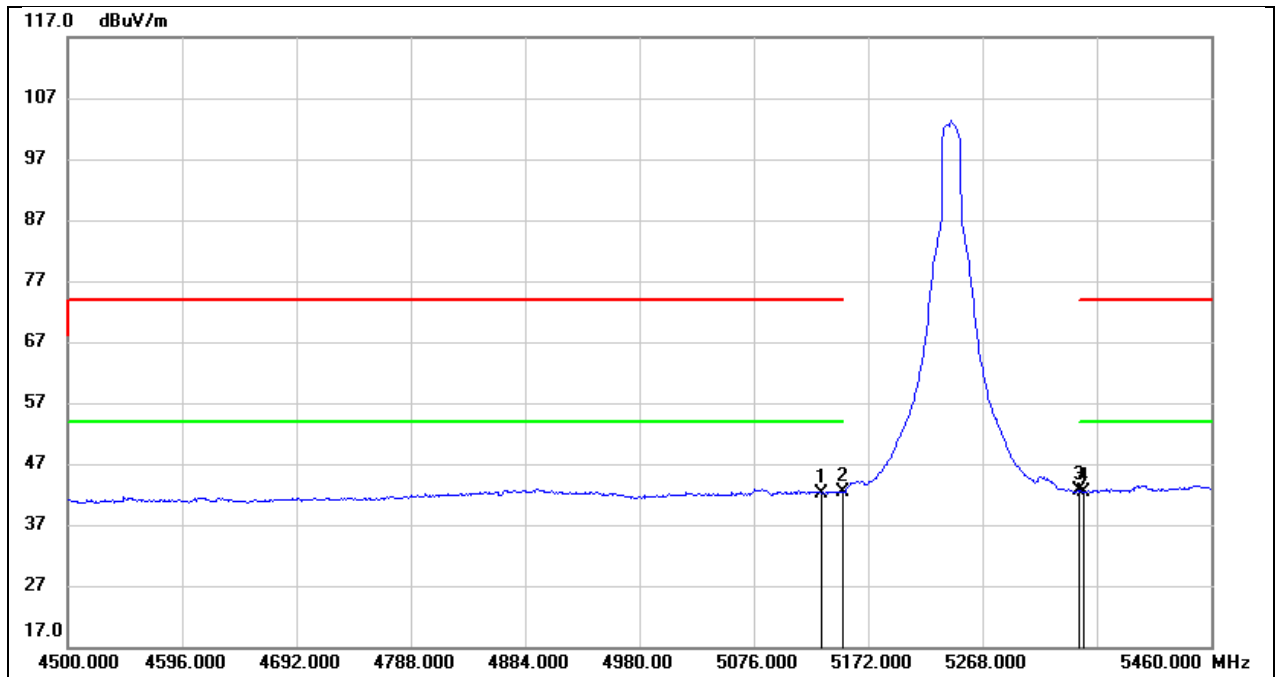

No.	Frequency (MHz)	Reading (dBuV)	Correct (dB/m)	Result (dBuV/m)	Limit (dBuV/m)	Margin (dB)	Remark
1	5132.640	3.42	38.81	42.23	54.00	-11.77	AVG
2	5150.000	3.63	38.84	42.47	54.00	-11.53	AVG
3	5350.000	3.32	39.29	42.61	54.00	-11.39	AVG
4	5353.440	3.13	39.30	42.43	54.00	-11.57	AVG

Test Mode:	802.11n HT20 PK	Frequency(MHz):	5260
Polarity:	Horizontal	Test Voltage:	AC 120V_60Hz

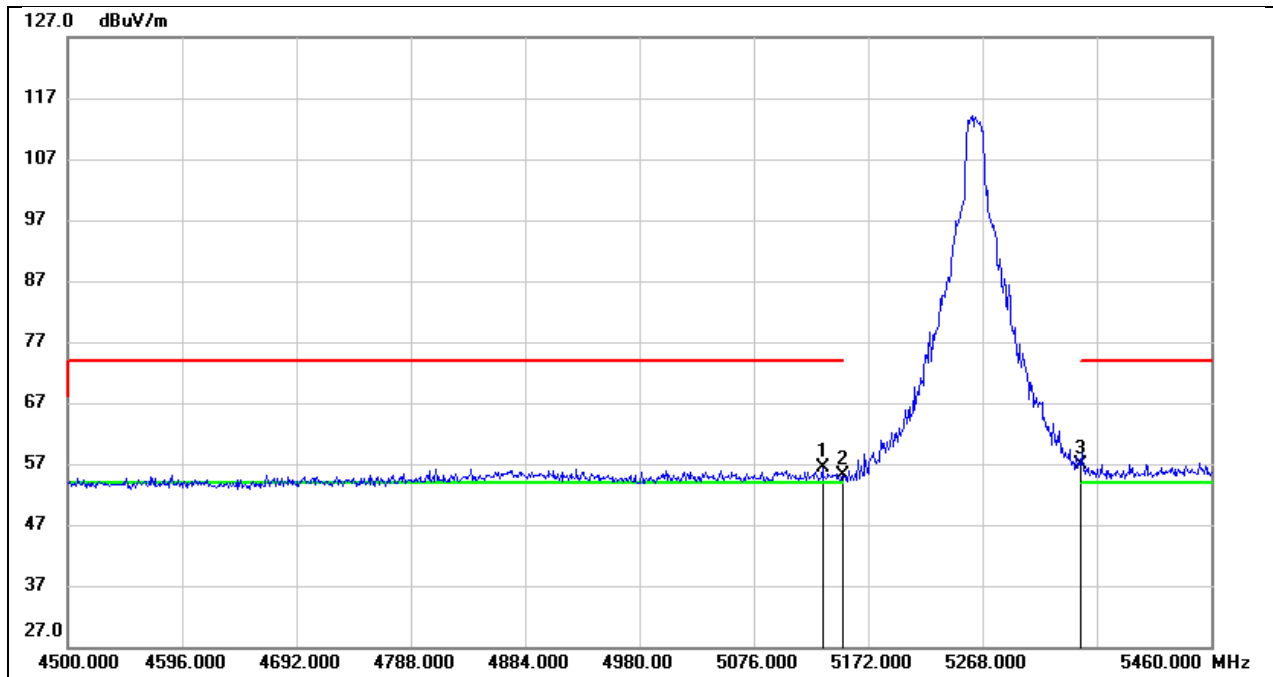

No.	Frequency (MHz)	Reading (dBuV)	Correct (dB/m)	Result (dBuV/m)	Limit (dBuV/m)	Margin (dB)	Remark
1	5133.600	17.54	38.81	56.35	74.00	-17.65	peak
2	5150.000	16.40	38.84	55.24	74.00	-18.76	peak
3	5350.000	17.71	39.29	57.00	74.00	-17.00	peak

Test Mode:	802.11n HT20 AV	Frequency(MHz):	5260
Polarity:	Horizontal	Test Voltage:	AC 120V_60Hz

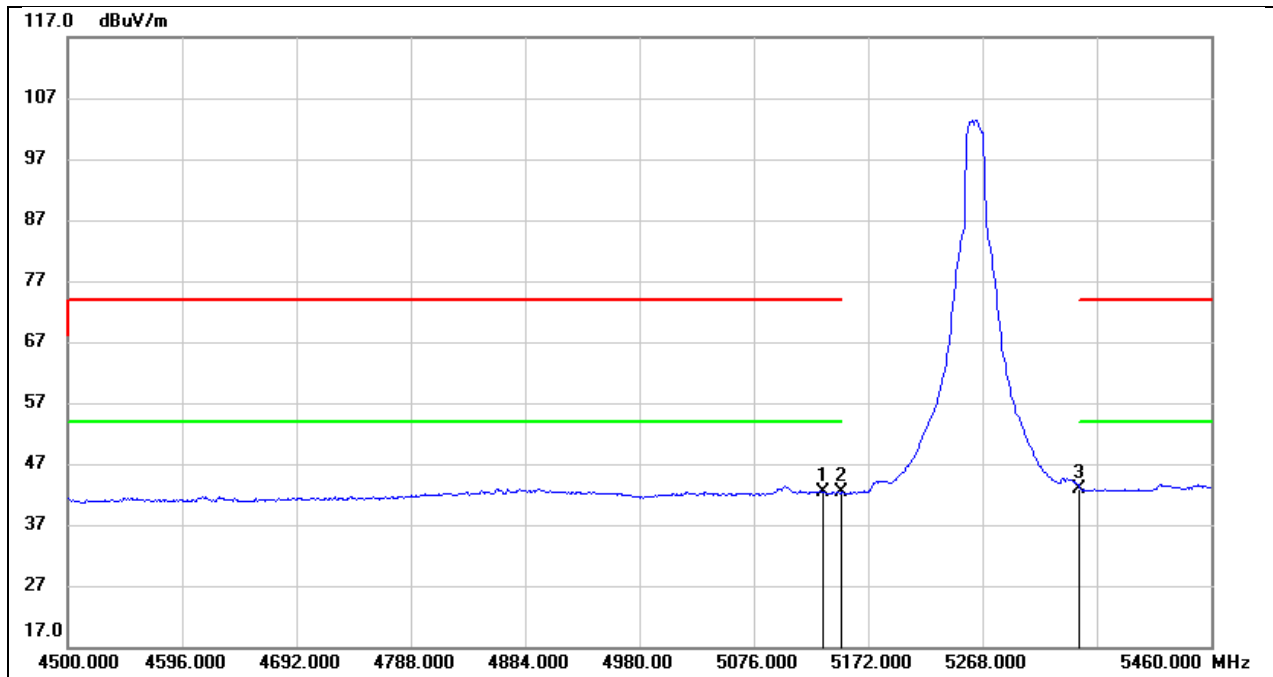

No.	Frequency (MHz)	Reading (dBuV)	Correct (dB/m)	Result (dBuV/m)	Limit (dBuV/m)	Margin (dB)	Remark
1	5133.600	3.57	38.81	42.38	54.00	-11.62	AVG
2	5150.000	3.42	38.84	42.26	54.00	-11.74	AVG
3	5350.000	3.52	39.29	42.81	54.00	-11.19	AVG

Test Mode:	802.11n HT20 PK	Frequency(MHz):	5280
Polarity:	Horizontal	Test Voltage:	AC 120V_60Hz

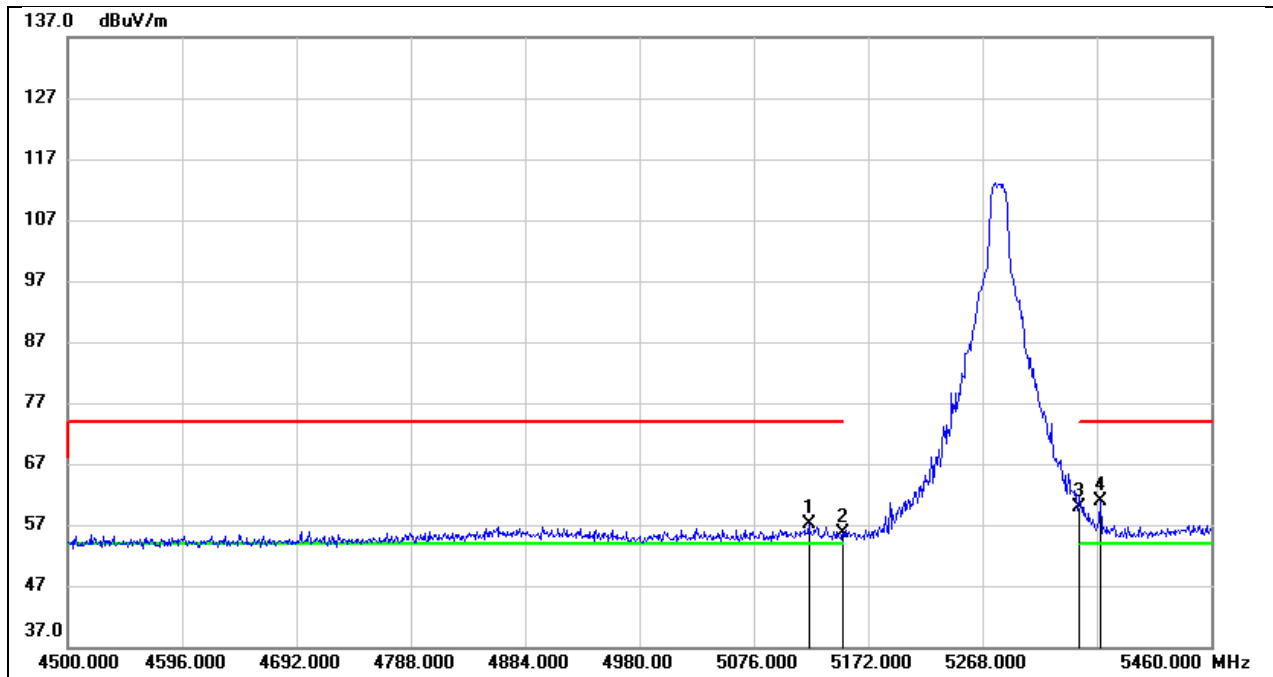

No.	Frequency (MHz)	Reading (dBuV)	Correct (dB/m)	Result (dBuV/m)	Limit (dBuV/m)	Margin (dB)	Remark
1	5122.080	18.28	38.85	57.13	74.00	-16.87	peak
2	5150.000	16.81	38.88	55.69	74.00	-18.31	peak
3	5350.000	20.53	39.25	59.78	74.00	-14.22	peak
4	5366.880	21.56	39.29	60.85	74.00	-13.15	peak

Test Mode:	802.11n HT20 AV	Frequency(MHz):	5280
Polarity:	Horizontal	Test Voltage:	AC 120V_60Hz

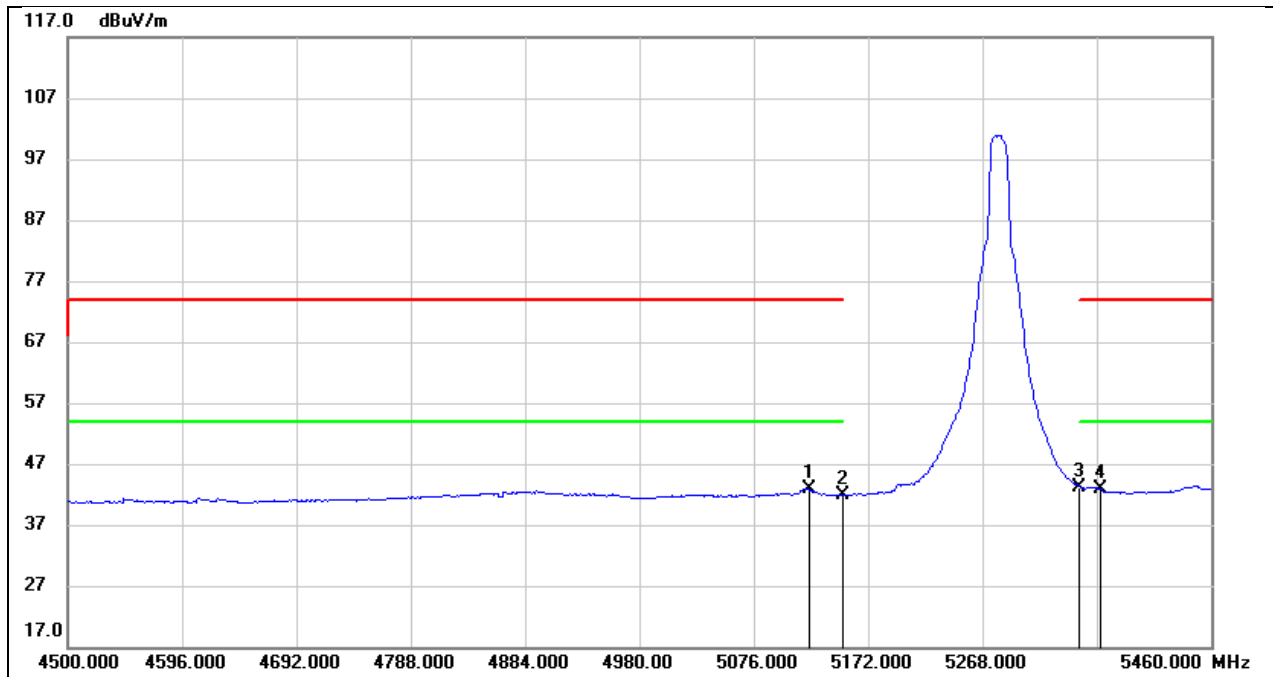

No.	Frequency (MHz)	Reading (dBuV)	Correct (dB/m)	Result (dBuV/m)	Limit (dBuV/m)	Margin (dB)	Remark
1	5122.080	3.94	38.85	42.79	54.00	-11.21	AVG
2	5150.000	3.02	38.88	41.90	54.00	-12.10	AVG
3	5350.000	3.97	39.25	43.22	54.00	-10.78	AVG
4	5366.880	3.51	39.29	42.80	54.00	-11.20	AVG

Test Mode:	802.11n HT20 PK	Frequency(MHz):	5320
Polarity:	Horizontal	Test Voltage:	AC 120V_60Hz

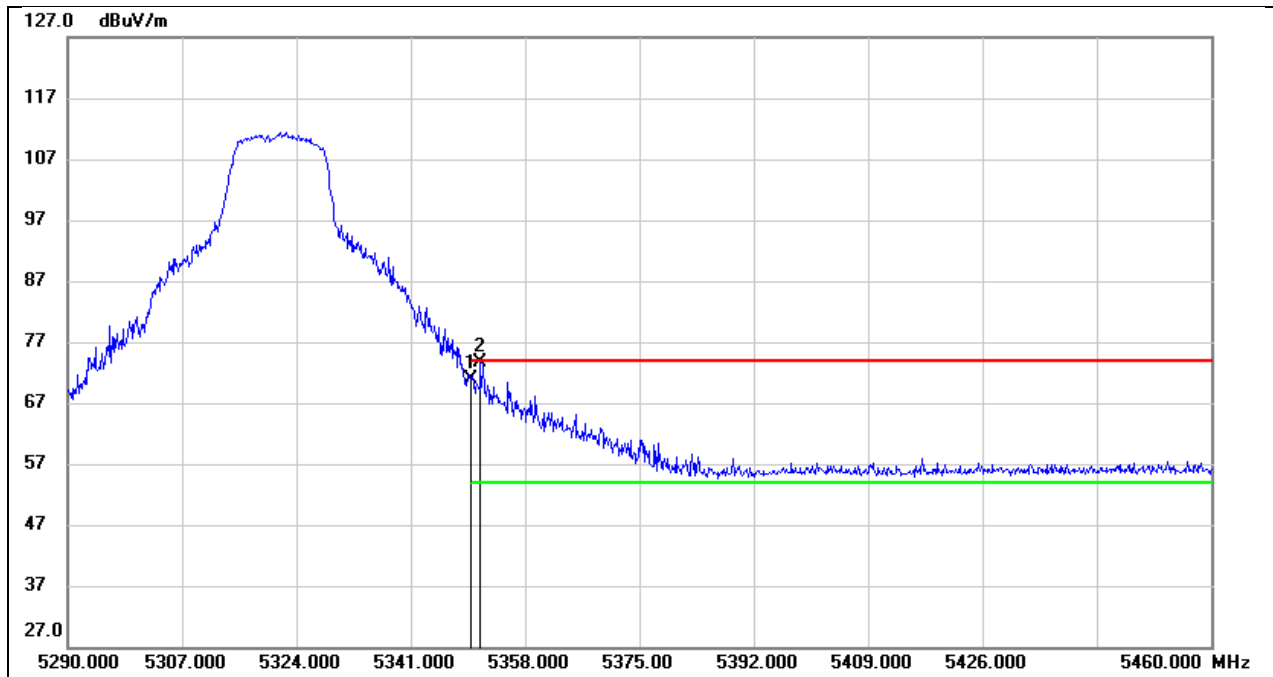

No.	Frequency (MHz)	Reading (dBuV)	Correct (dB/m)	Result (dBuV/m)	Limit (dBuV/m)	Margin (dB)	Remark
1	5350.000	31.58	39.29	70.87	74.00	-3.13	peak
2	5351.370	34.32	39.30	73.62	74.00	-0.38	peak



Test Mode:	802.11n HT20 AV	Frequency(MHz):	5320
Polarity:	Horizontal	Test Voltage:	AC 120V_60Hz

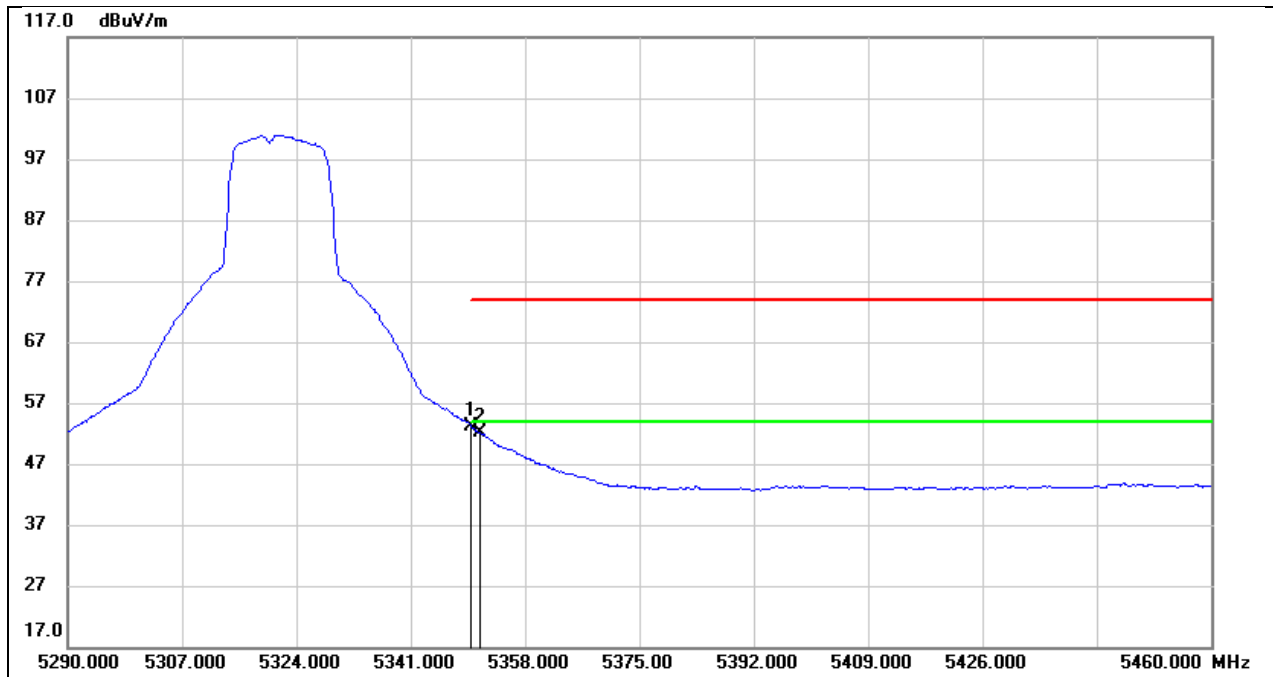

No.	Frequency (MHz)	Reading (dBuV)	Correct (dB/m)	Result (dBuV/m)	Limit (dBuV/m)	Margin (dB)	Remark
1	5350.000	13.73	39.29	53.02	54.00	-0.98	AVG
2	5351.370	12.75	39.30	52.05	54.00	-1.95	AVG

Test Mode:	802.11n HT20 PK	Frequency(MHz):	5500
Polarity:	Horizontal	Test Voltage:	DC 5V

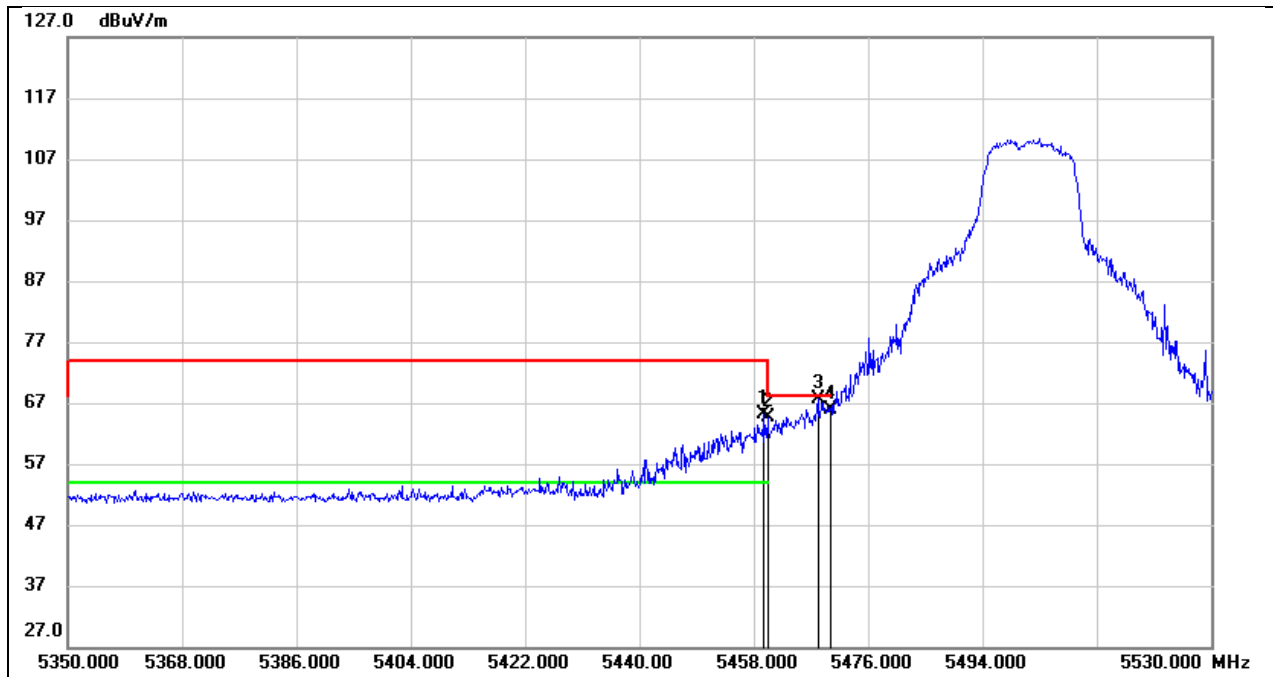

No.	Frequency (MHz)	Reading (dBuV)	Correct (dB/m)	Result (dBuV/m)	Limit (dBuV/m)	Margin (dB)	Remark
1	5459.620	31.03	34.00	65.03	74.00	-8.97	peak
2	5460.000	30.55	34.00	64.55	74.00	-9.45	peak
3	5468.080	33.75	33.99	67.74	68.20	-0.46	peak
4	5470.000	31.81	33.99	65.80	68.20	-2.40	peak

Test Mode:	802.11n HT20 AV	Frequency(MHz):	5500
Polarity:	Horizontal	Test Voltage:	DC 5V

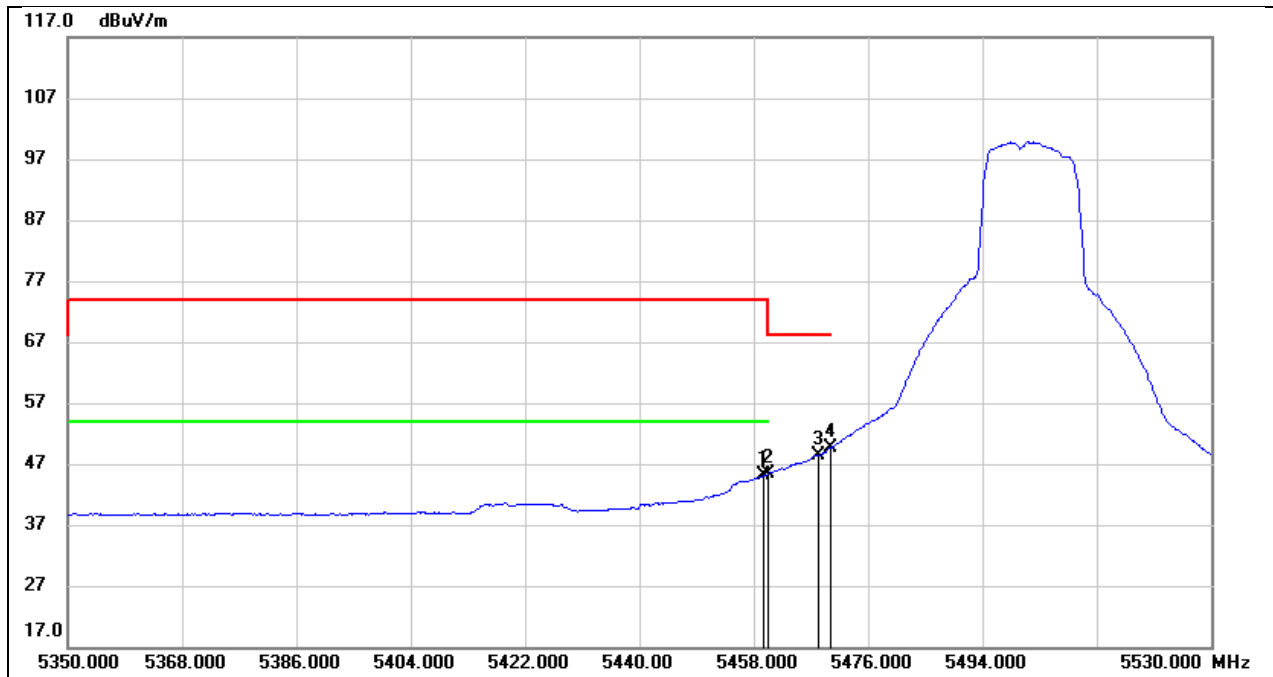

No.	Frequency (MHz)	Reading (dBuV)	Correct (dB/m)	Result (dBuV/m)	Limit (dBuV/m)	Margin (dB)	Remark
1	5459.620	11.03	34.00	45.03	54.00	-8.97	AVG
2	5460.000	11.33	34.00	45.33	54.00	-8.67	AVG
3	5468.080	14.47	33.99	48.46	/	/	AVG
4	5470.000	15.64	33.99	49.63	/	/	AVG

Test Mode:	802.11n HT20 PK	Frequency(MHz):	5580
Polarity:	Horizontal	Test Voltage:	AC 120V_60Hz

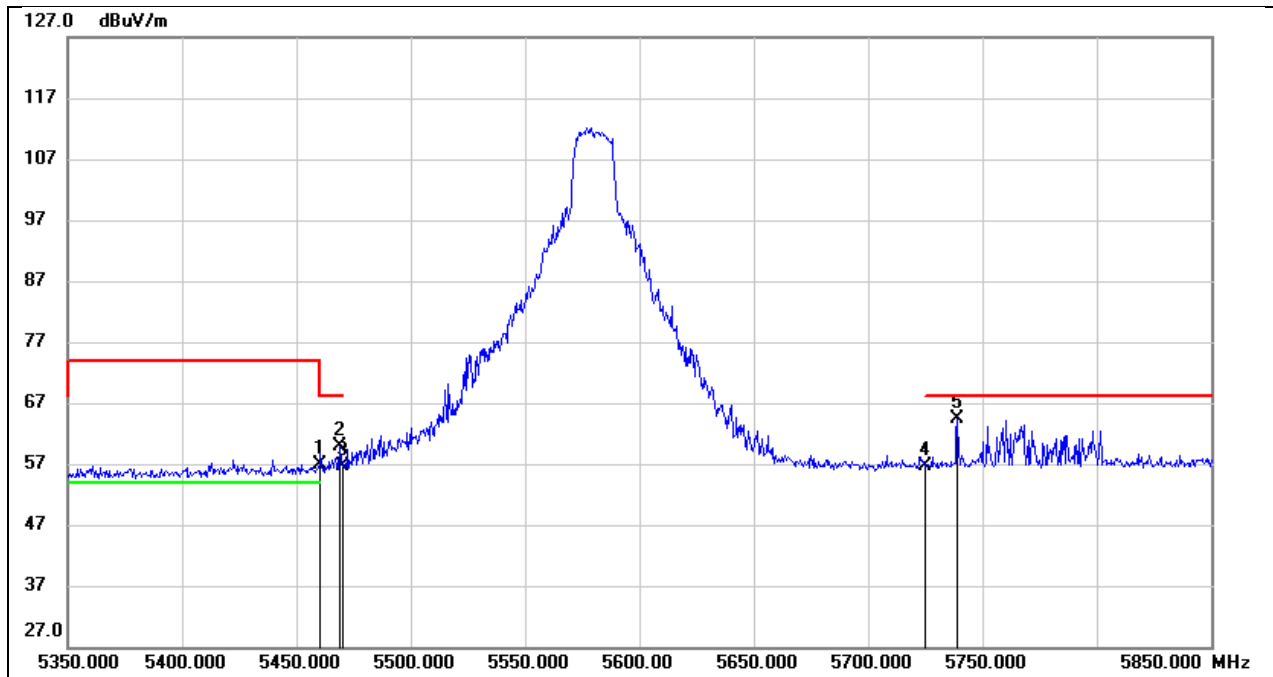

No.	Frequency (MHz)	Reading (dBuV)	Correct (dB/m)	Result (dBuV/m)	Limit (dBuV/m)	Margin (dB)	Remark
1	5460.000	17.42	39.56	56.98	74.00	-17.02	peak
2	5469.000	20.25	39.58	59.83	68.20	-8.37	peak
3	5470.000	17.13	39.58	56.71	68.20	-11.49	peak
4	5725.000	16.50	40.09	56.59	68.20	-11.61	peak
5	5739.000	24.23	40.10	64.33	68.20	-3.87	peak

Test Mode:	802.11n HT20 AV	Frequency(MHz):	5580
Polarity:	Horizontal	Test Voltage:	AC 120V_60Hz

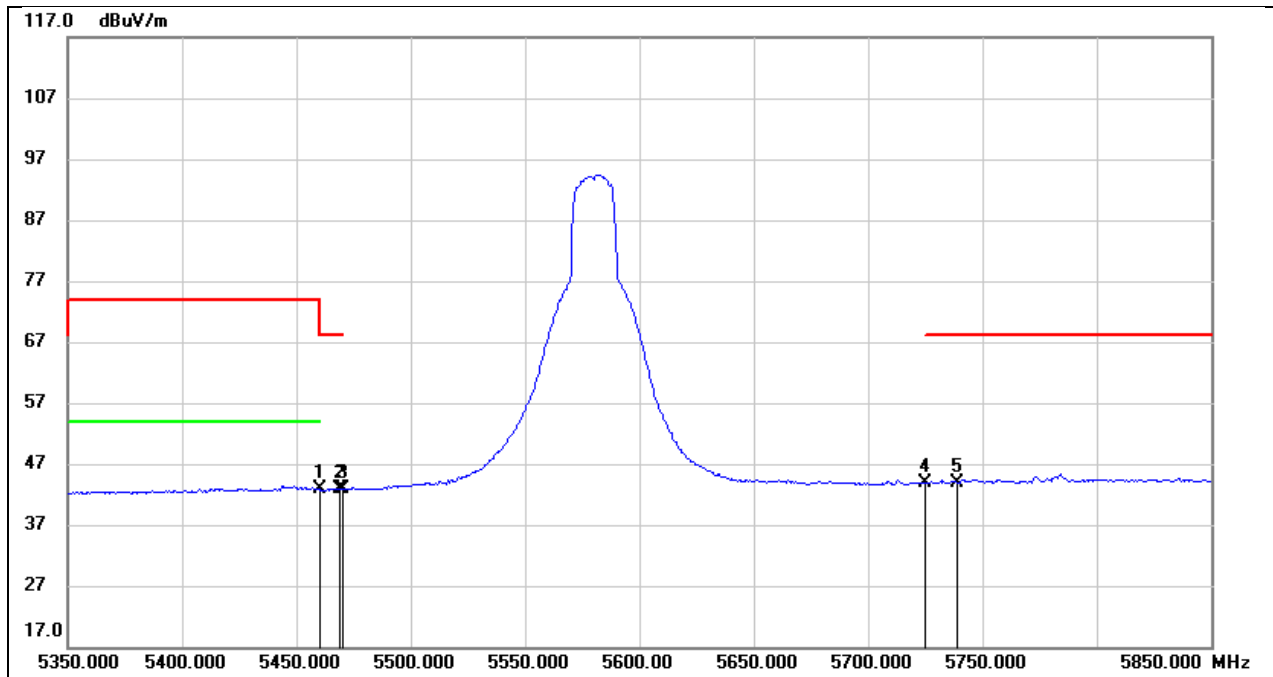

No.	Frequency (MHz)	Reading (dBuV)	Correct (dB/m)	Result (dBuV/m)	Limit (dBuV/m)	Margin (dB)	Remark
1	5460.000	3.22	39.56	42.78	54.00	-11.22	AVG
2	5469.000	3.30	39.58	42.88	/	/	AVG
3	5470.000	3.21	39.58	42.79	/	/	AVG
4	5725.000	3.83	40.09	43.92	/	/	AVG
5	5739.000	3.78	40.10	43.88	/	/	AVG

Test Mode:	802.11n HT20 PK	Frequency(MHz):	5700
Polarity:	Horizontal	Test Voltage:	DC 5V

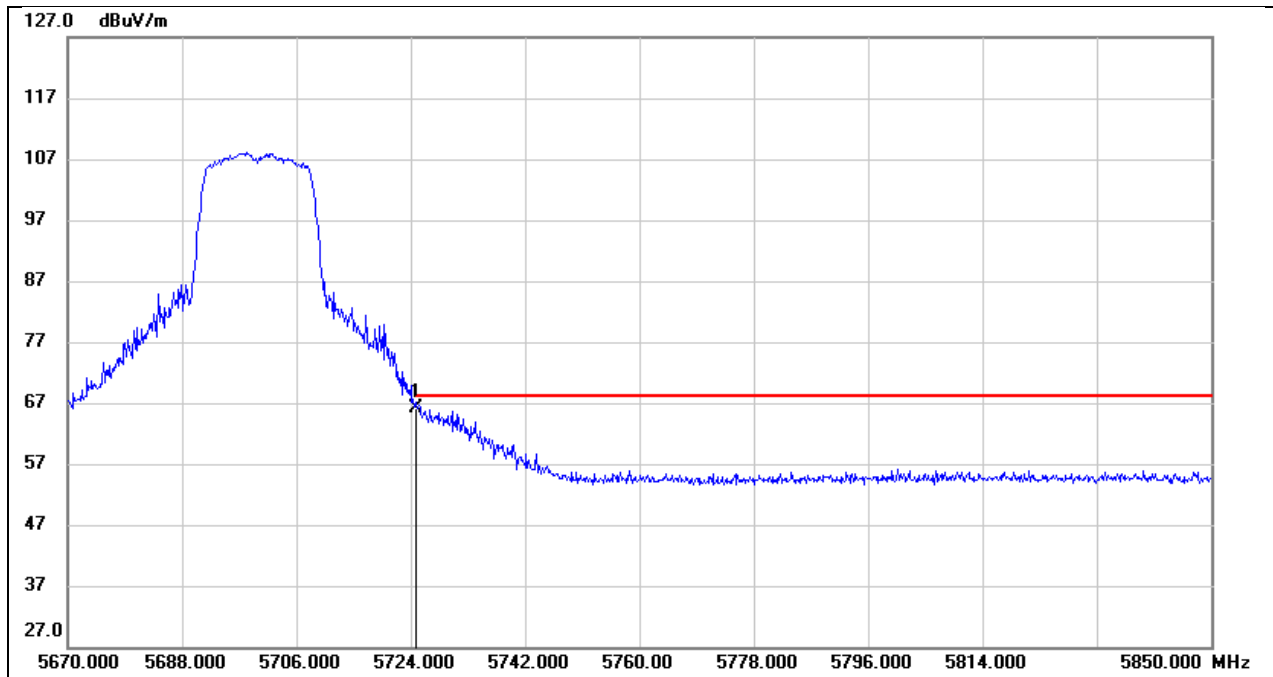

No.	Frequency (MHz)	Reading (dBuV)	Correct (dB/m)	Result (dBuV/m)	Limit (dBuV/m)	Margin (dB)	Remark
1	5725.000	30.78	35.28	66.06	68.20	-2.14	peak

Test Mode:	802.11n HT20 PK	Frequency(MHz):	5745
Polarity:	Horizontal	Test Voltage:	AC 120V_60Hz

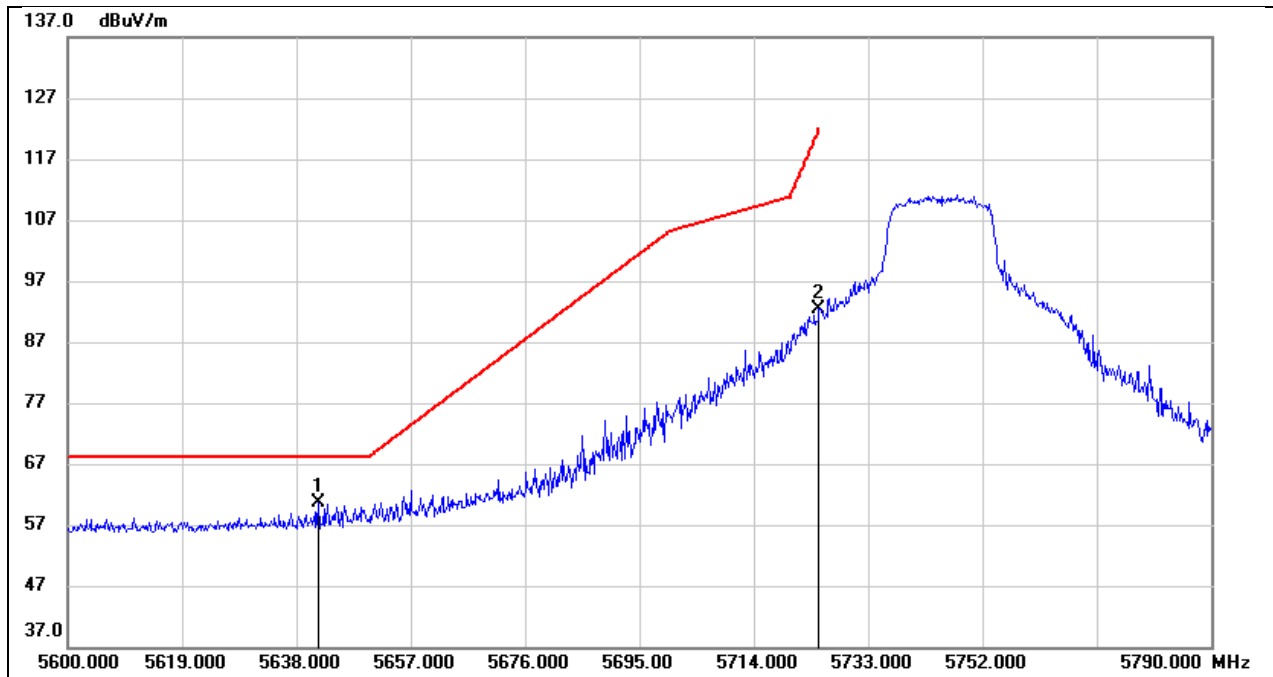

No.	Frequency (MHz)	Reading (dBuV)	Correct (dB/m)	Result (dBuV/m)	Limit (dBuV/m)	Margin (dB)	Remark
1	5641.610	20.66	39.99	60.65	68.20	-7.55	peak
2	5725.000	52.29	40.09	92.38	122.20	-29.82	peak

Test Mode:	802.11n HT20 PK	Frequency(MHz):	5785
Polarity:	Horizontal	Test Voltage:	AC 120V_60Hz

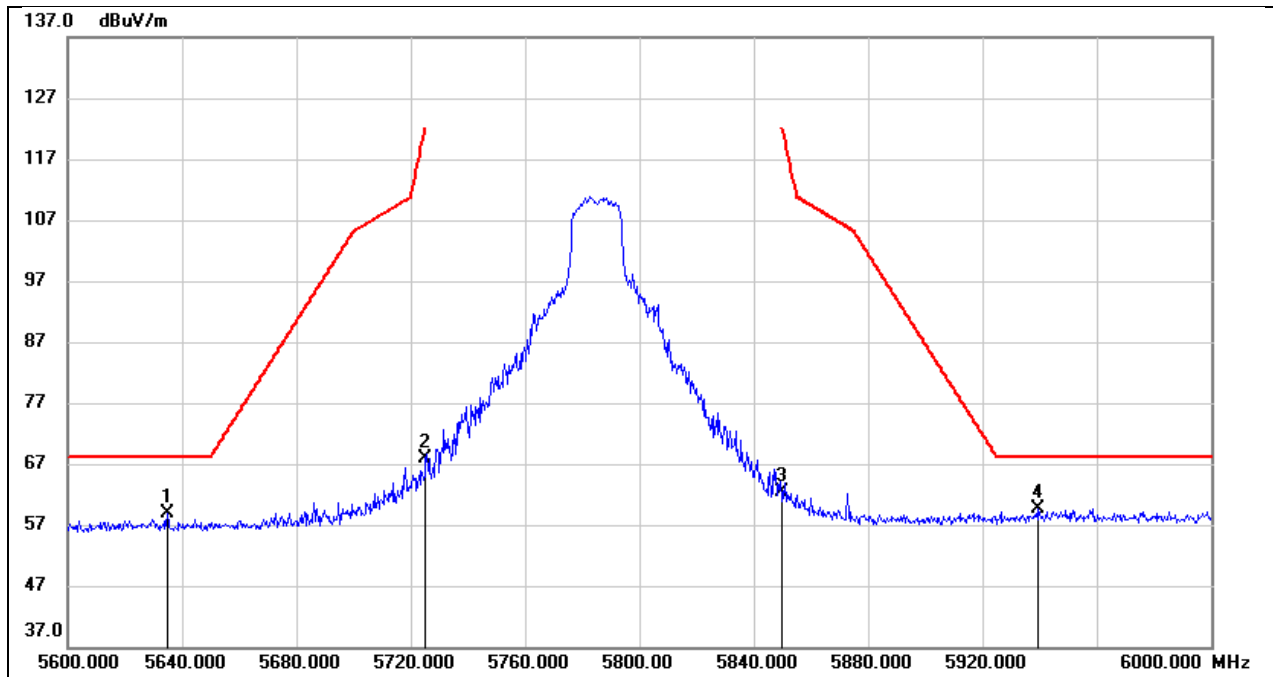

No.	Frequency (MHz)	Reading (dBuV)	Correct (dB/m)	Result (dBuV/m)	Limit (dBuV/m)	Margin (dB)	Remark
1	5634.800	19.00	39.98	58.98	68.20	-9.22	peak
2	5725.000	27.88	40.09	67.97	122.20	-54.23	peak
3	5850.000	22.00	40.30	62.30	122.20	-59.90	peak
4	5939.600	19.10	40.50	59.60	68.20	-8.60	peak



Test Mode:	802.11n HT20 PK	Frequency(MHz):	5825
Polarity:	Horizontal	Test Voltage:	AC 120V_60Hz

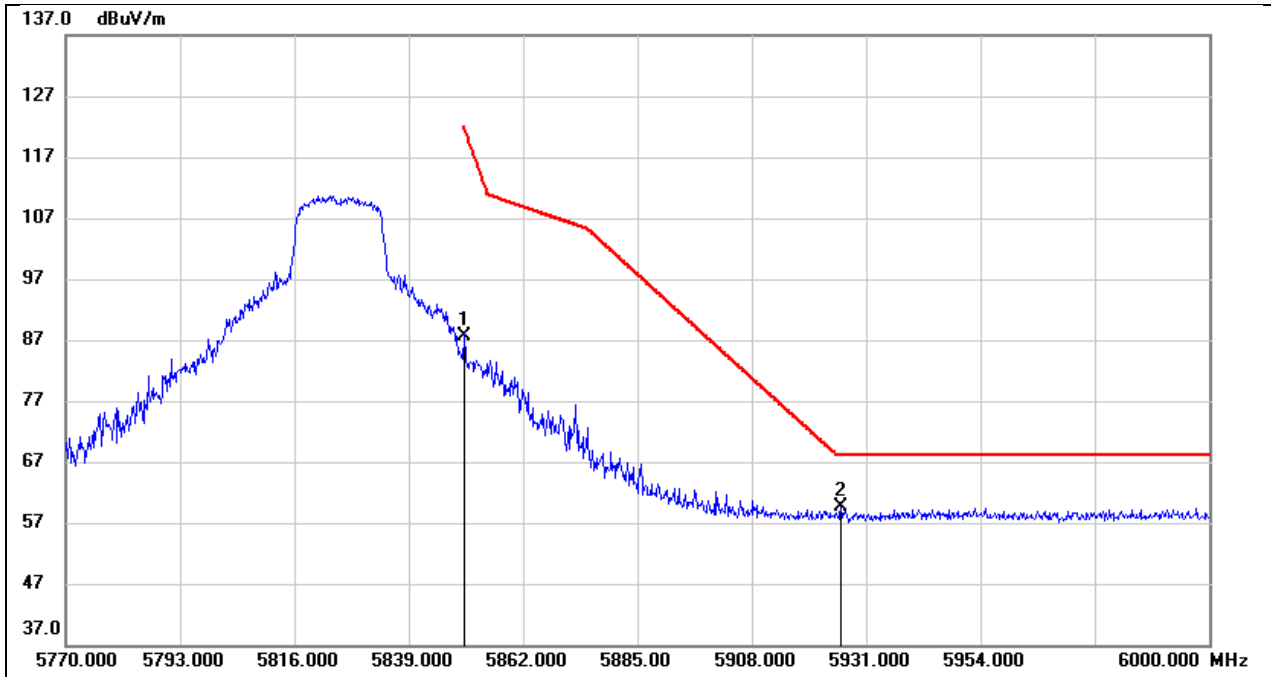

No.	Frequency (MHz)	Reading (dBuV)	Correct (dB/m)	Result (dBuV/m)	Limit (dBuV/m)	Margin (dB)	Remark
1	5850.000	47.38	40.30	87.68	122.20	-34.52	peak
2	5925.940	19.22	40.47	59.69	68.20	-8.51	peak

## 8.2. SPURIOUS EMISSIONS(1 GHZ~7 GHZ)

Test Mode:	802.11a 20	Frequency(MHz):	5180
Polarity:	Horizontal	Test Voltage:	AC 120V_60Hz

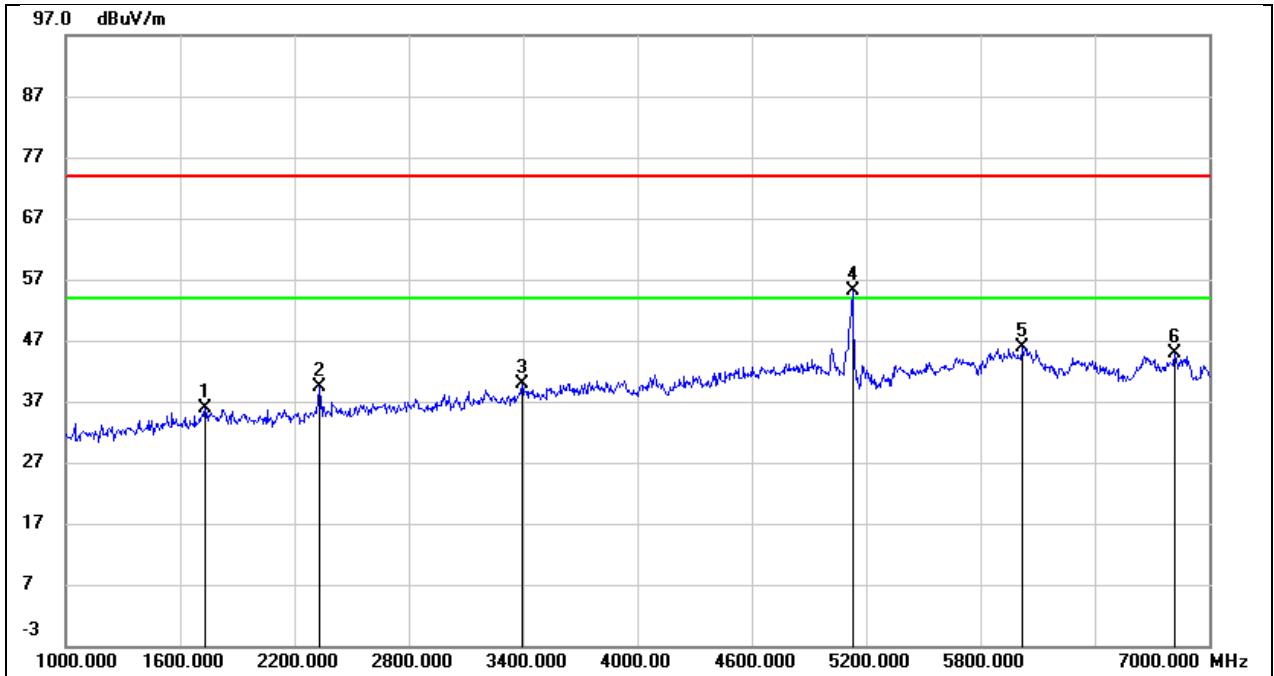

No.	Frequency (MHz)	Reading (dBuV)	Correct (dB/m)	Result (dBuV/m)	Limit (dBuV/m)	Margin (dB)	Remark
1	1732.000	46.34	-10.44	35.90	74.00	-38.10	peak
2	2332.000	48.12	-8.85	39.27	74.00	-34.73	peak
3	3394.000	44.22	-4.23	39.99	74.00	-34.01	peak
4	5180.000	53.13	1.95	55.08	/	/	Fundamental
5	6022.000	40.26	5.71	45.97	74.00	-28.03	peak
6	6820.000	38.23	6.59	44.82	74.00	-29.18	peak

Test Mode:	802.11a 20	Frequency(MHz):	5180
Polarity:	Vertical	Test Voltage:	AC 120V_60Hz

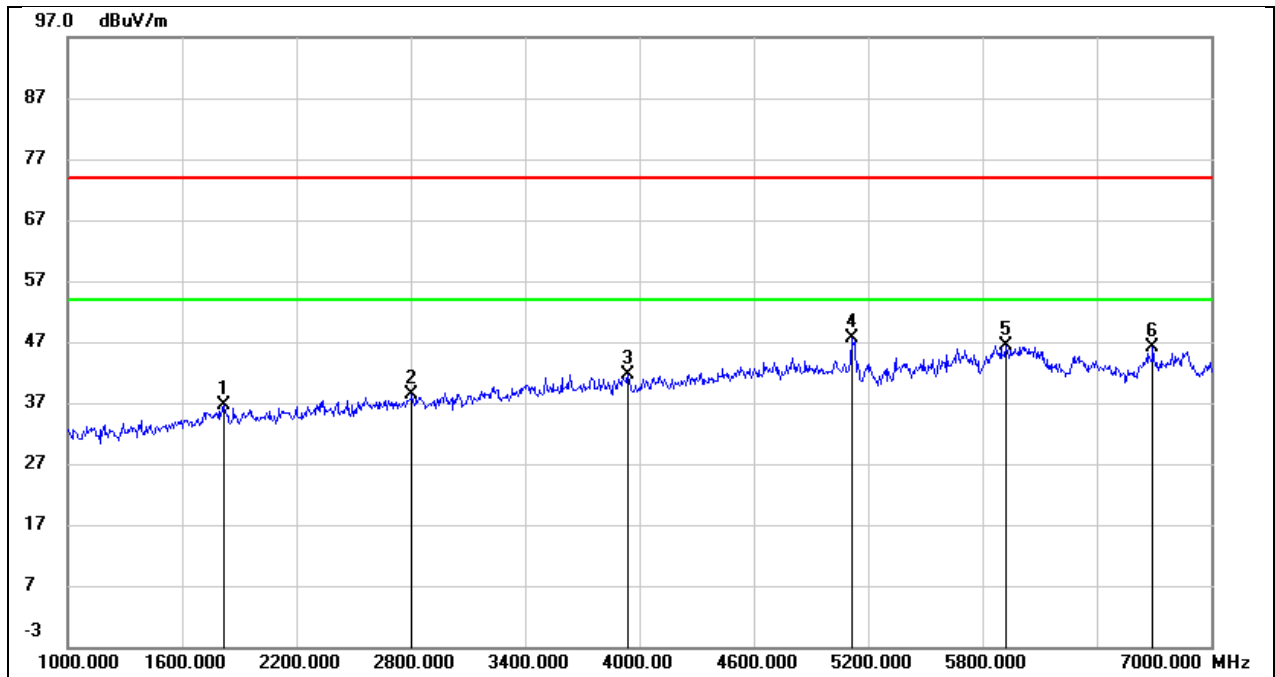

No.	Frequency (MHz)	Reading (dBuV)	Correct (dB/m)	Result (dBuV/m)	Limit (dBuV/m)	Margin (dB)	Remark
1	1816.000	46.09	-9.37	36.72	74.00	-37.28	peak
2	2806.000	44.09	-5.79	38.30	74.00	-35.70	peak
3	3940.000	43.06	-1.44	41.62	74.00	-32.38	peak
4	5116.000	44.58	3.14	47.72	74.00	-26.28	peak
5	5920.000	40.13	6.21	46.34	74.00	-27.66	peak
6	6694.000	39.02	7.17	46.19	74.00	-27.81	peak

Test Mode:	802.11a 20	Frequency(MHz):	5200
Polarity:	Horizontal	Test Voltage:	AC 120V_60Hz

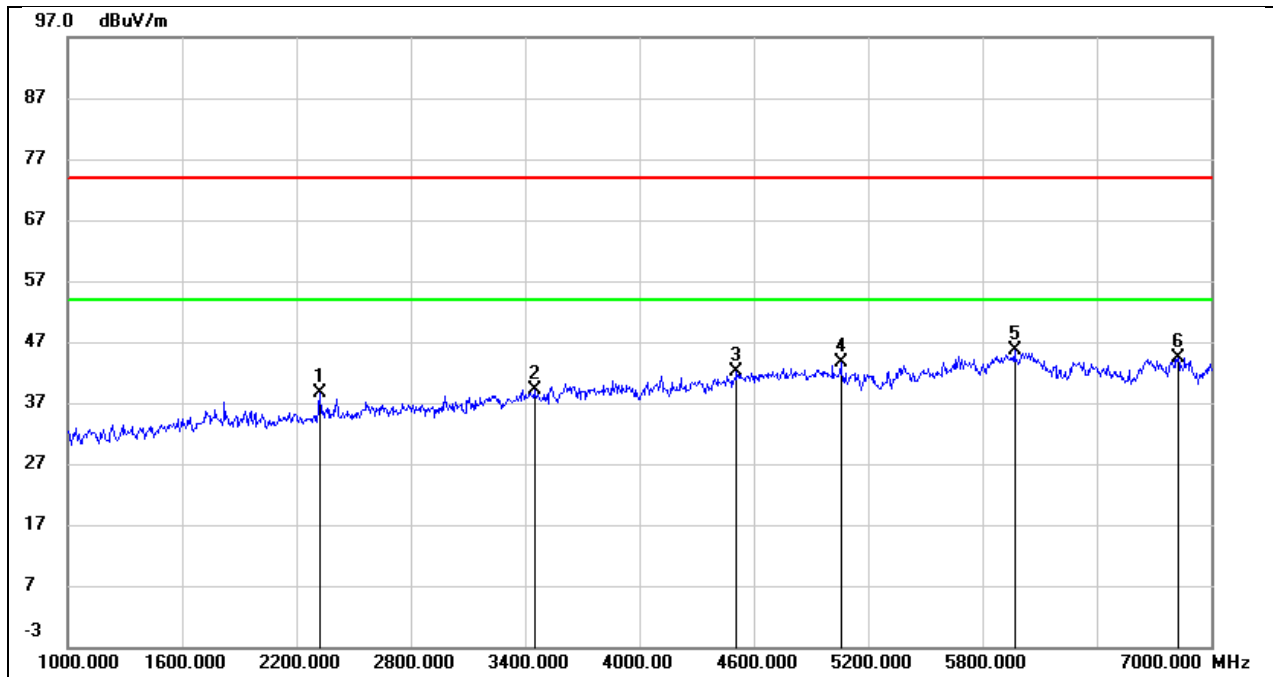

No.	Frequency (MHz)	Reading (dBuV)	Correct (dB/m)	Result (dBuV/m)	Limit (dBuV/m)	Margin (dB)	Remark
1	2320.000	47.60	-8.89	38.71	74.00	-35.29	peak
2	3448.000	43.18	-4.00	39.18	74.00	-34.82	peak
3	4510.000	42.51	-0.38	42.13	74.00	-31.87	peak
4	5056.000	41.88	1.87	43.75	74.00	-30.25	peak
5	5968.000	40.06	5.45	45.51	74.00	-28.49	peak
6	6826.000	37.79	6.59	44.38	74.00	-29.62	peak

Test Mode:	802.11a 20	Frequency(MHz):	5200
Polarity:	Vertical	Test Voltage:	AC 120V_60Hz

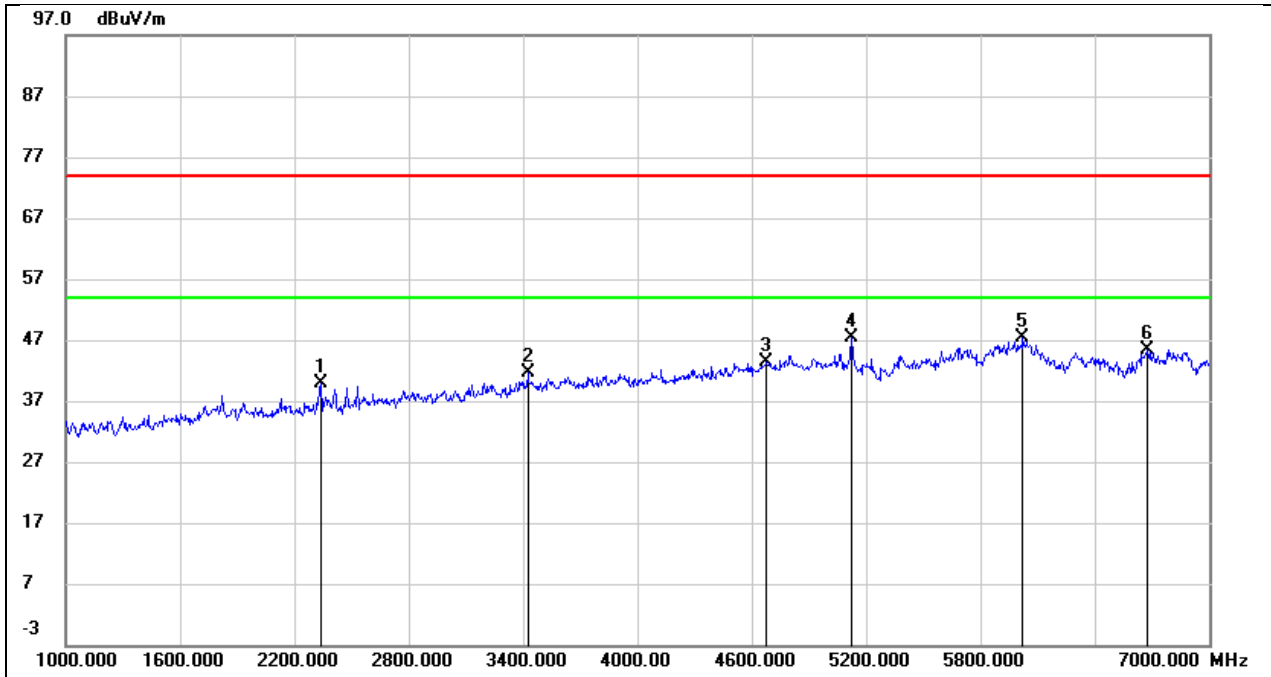

No.	Frequency (MHz)	Reading (dBuV)	Correct (dB/m)	Result (dBuV/m)	Limit (dBuV/m)	Margin (dB)	Remark
1	2338.000	47.89	-7.99	39.90	74.00	-34.10	peak
2	3424.000	44.71	-3.06	41.65	74.00	-32.35	peak
3	4678.000	41.92	1.39	43.31	74.00	-30.69	peak
4	5122.000	44.24	3.15	47.39	74.00	-26.61	peak
5	6022.000	40.60	6.71	47.31	74.00	-26.69	peak
6	6676.000	38.26	7.12	45.38	74.00	-28.62	peak

Test Mode:	802.11a 20	Frequency(MHz):	5240
Polarity:	Horizontal	Test Voltage:	AC 120V_60Hz

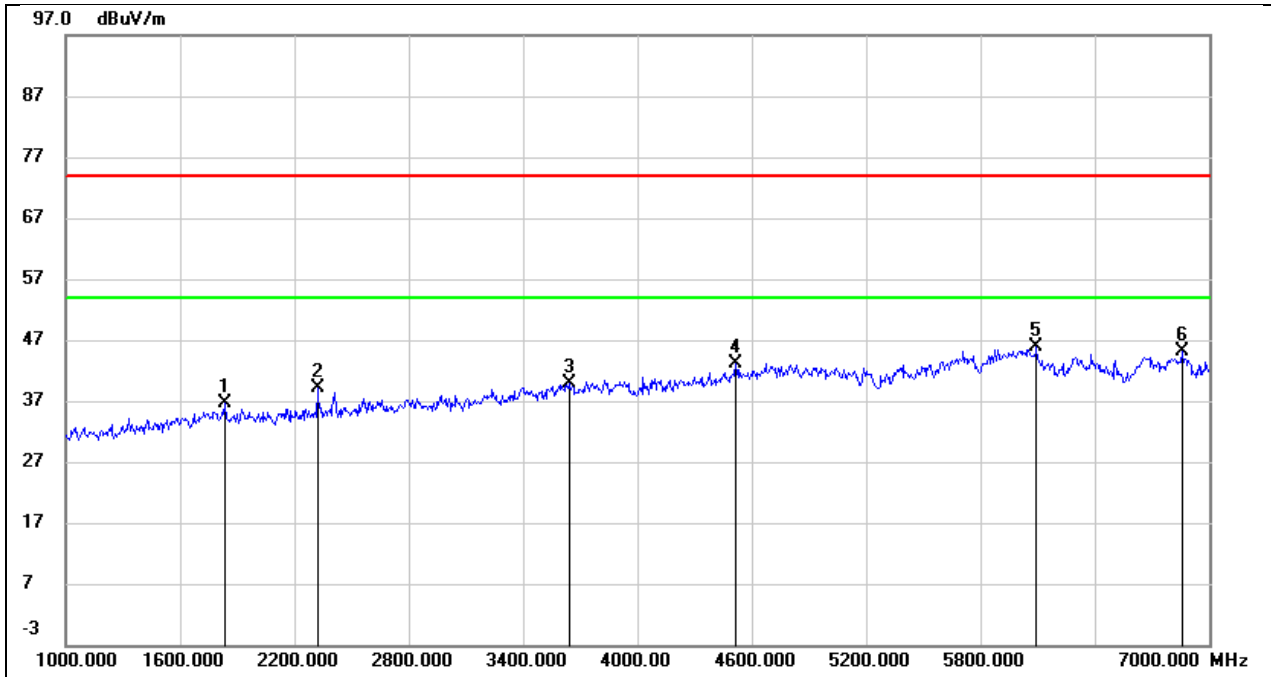

No.	Frequency (MHz)	Reading (dBuV)	Correct (dB/m)	Result (dBuV/m)	Limit (dBuV/m)	Margin (dB)	Remark
1	1834.000	46.54	-9.99	36.55	74.00	-37.45	peak
2	2320.000	47.95	-8.89	39.06	74.00	-34.94	peak
3	3640.000	42.98	-3.20	39.78	74.00	-34.22	peak
4	4516.000	43.48	-0.35	43.13	74.00	-30.87	peak
5	6094.000	39.94	5.99	45.93	74.00	-28.07	peak
6	6856.000	38.64	6.56	45.20	74.00	-28.80	peak

Test Mode:	802.11a 20	Frequency(MHz):	5240
Polarity:	Vertical	Test Voltage:	AC 120V_60Hz

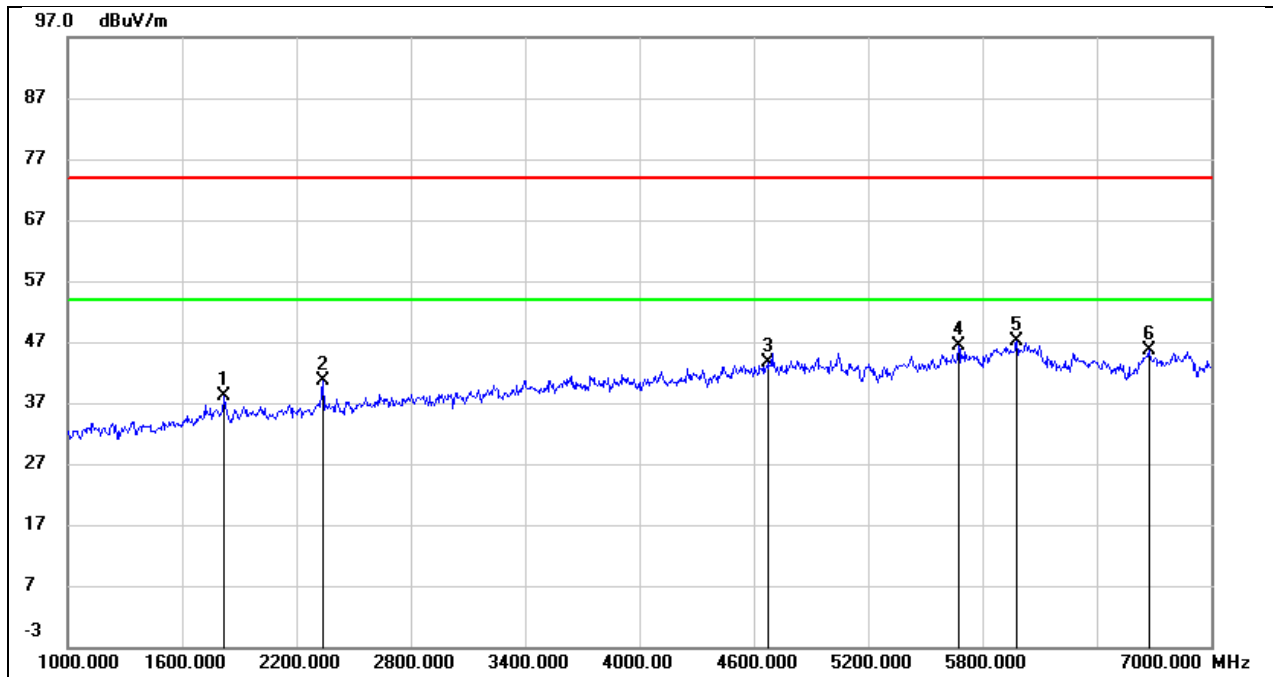

No.	Frequency (MHz)	Reading (dBuV)	Correct (dB/m)	Result (dBuV/m)	Limit (dBuV/m)	Margin (dB)	Remark
1	1822.000	47.51	-9.37	38.14	74.00	-35.86	peak
2	2338.000	48.58	-7.99	40.59	74.00	-33.41	peak
3	4678.000	42.29	1.39	43.68	74.00	-30.32	peak
4	5674.000	41.19	5.07	46.26	74.00	-27.74	peak
5	5980.000	40.63	6.53	47.16	74.00	-26.84	peak
6	6676.000	38.45	7.12	45.57	74.00	-28.43	peak

Test Mode:	802.11a 20	Frequency(MHz):	5260
Polarity:	Horizontal	Test Voltage:	AC 120V_60Hz

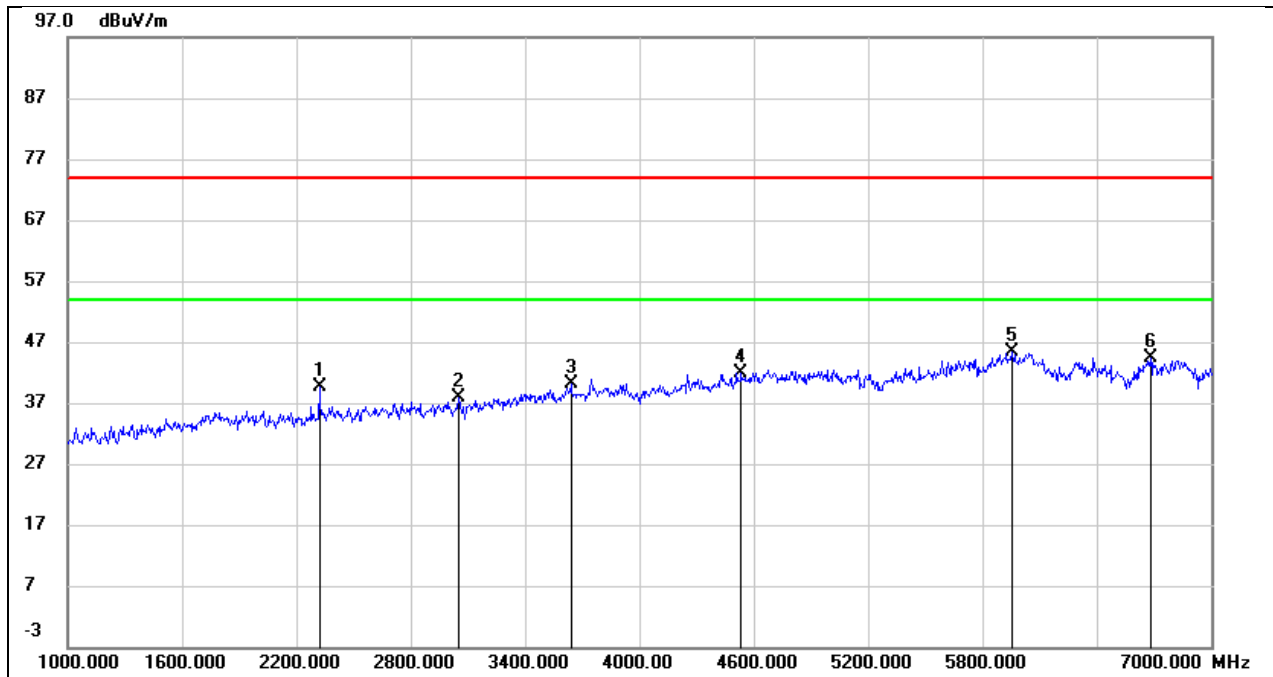

No.	Frequency (MHz)	Reading (dBuV)	Correct (dB/m)	Result (dBuV/m)	Limit (dBuV/m)	Margin (dB)	Remark
1	2320.000	48.42	-8.89	39.53	74.00	-34.47	peak
2	3052.000	43.53	-5.76	37.77	74.00	-36.23	peak
3	3640.000	43.33	-3.20	40.13	74.00	-33.87	peak
4	4534.000	42.22	-0.26	41.96	74.00	-32.04	peak
5	5956.000	40.07	5.38	45.45	74.00	-28.55	peak
6	6682.000	38.08	6.30	44.38	74.00	-29.62	peak



Test Mode:	802.11a 20	Frequency(MHz):	5260
Polarity:	Vertical	Test Voltage:	AC 120V_60Hz

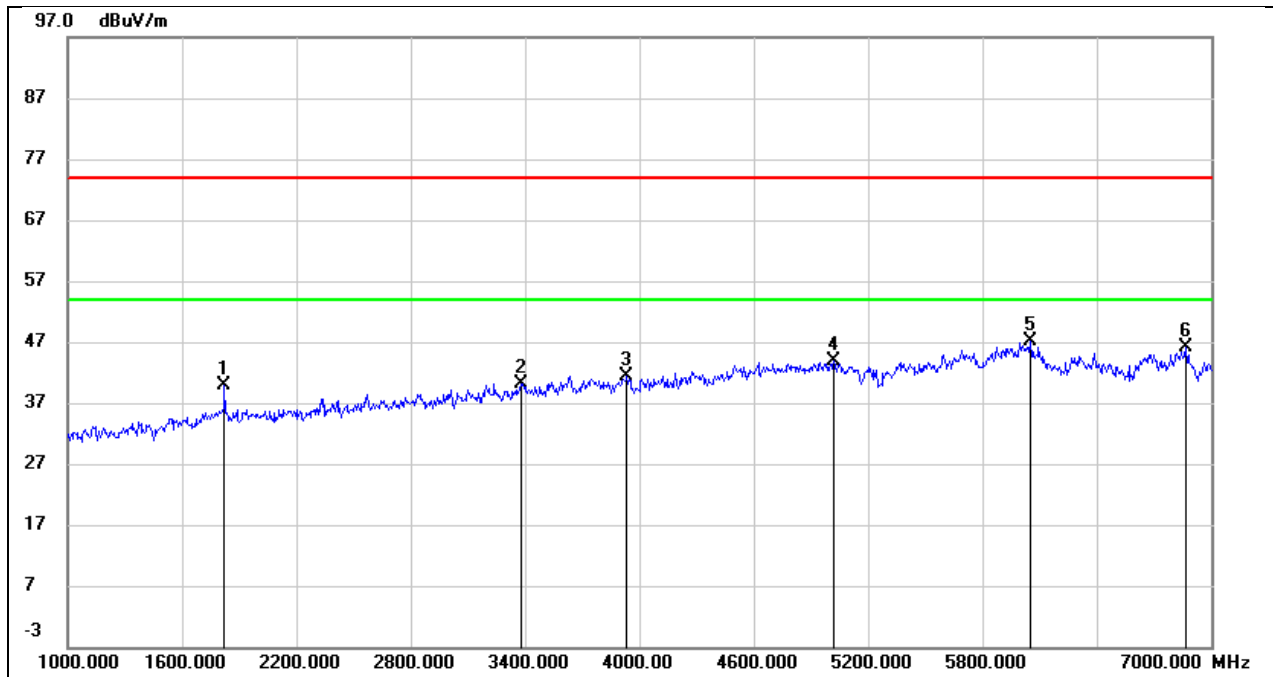

No.	Frequency (MHz)	Reading (dBuV)	Correct (dB/m)	Result (dBuV/m)	Limit (dBuV/m)	Margin (dB)	Remark
1	1822.000	49.16	-9.37	39.79	74.00	-34.21	peak
2	3382.000	43.44	-3.21	40.23	74.00	-33.77	peak
3	3934.000	42.90	-1.44	41.46	74.00	-32.54	peak
4	5020.000	40.97	3.02	43.99	74.00	-30.01	peak
5	6052.000	40.40	6.80	47.20	74.00	-26.80	peak
6	6868.000	38.67	7.43	46.10	74.00	-27.90	peak

Test Mode:	802.11a 20	Frequency(MHz):	5280
Polarity:	Horizontal	Test Voltage:	AC 120V_60Hz

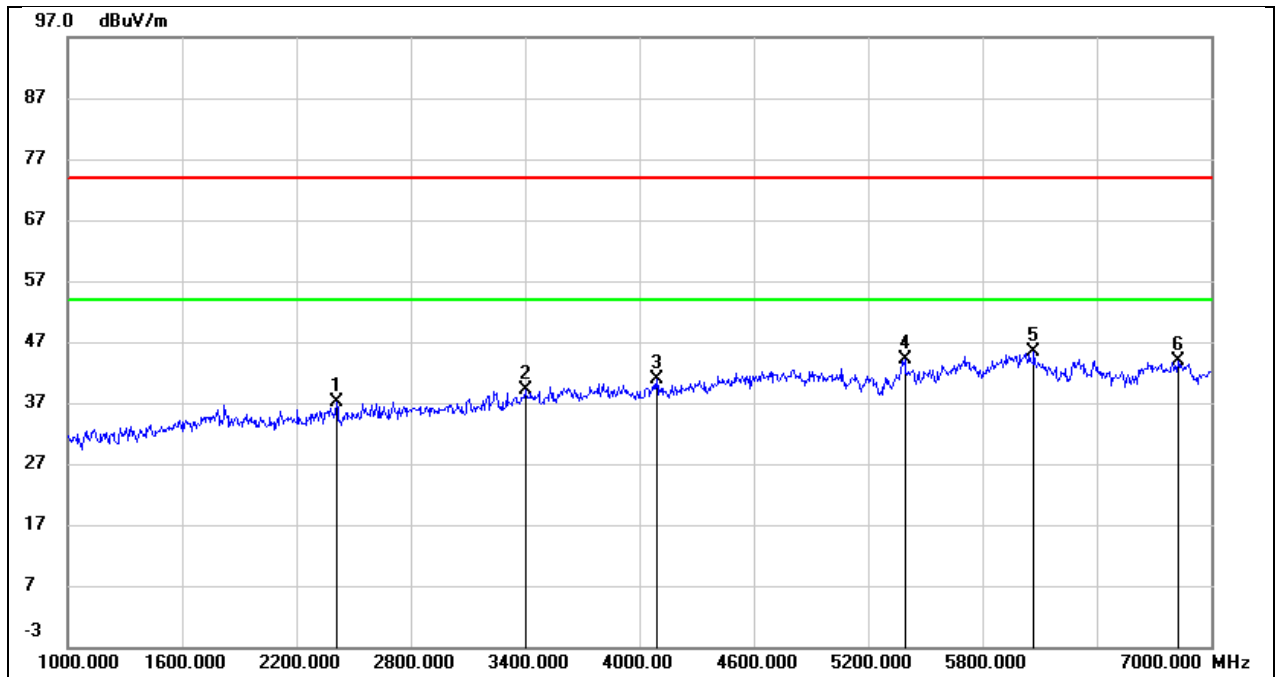

No.	Frequency (MHz)	Reading (dBuV)	Correct (dB/m)	Result (dBuV/m)	Limit (dBuV/m)	Margin (dB)	Remark
1	2410.000	45.69	-8.55	37.14	74.00	-36.86	peak
2	3400.000	43.37	-4.21	39.16	74.00	-34.84	peak
3	4090.000	43.03	-2.07	40.96	74.00	-33.04	peak
4	5392.000	41.23	2.89	44.12	74.00	-29.88	peak
5	6070.000	39.42	5.89	45.31	74.00	-28.69	peak
6	6826.000	37.17	6.59	43.76	74.00	-30.24	peak

Test Mode:	802.11a 20	Frequency(MHz):	5280
Polarity:	Vertical	Test Voltage:	AC 120V_60Hz

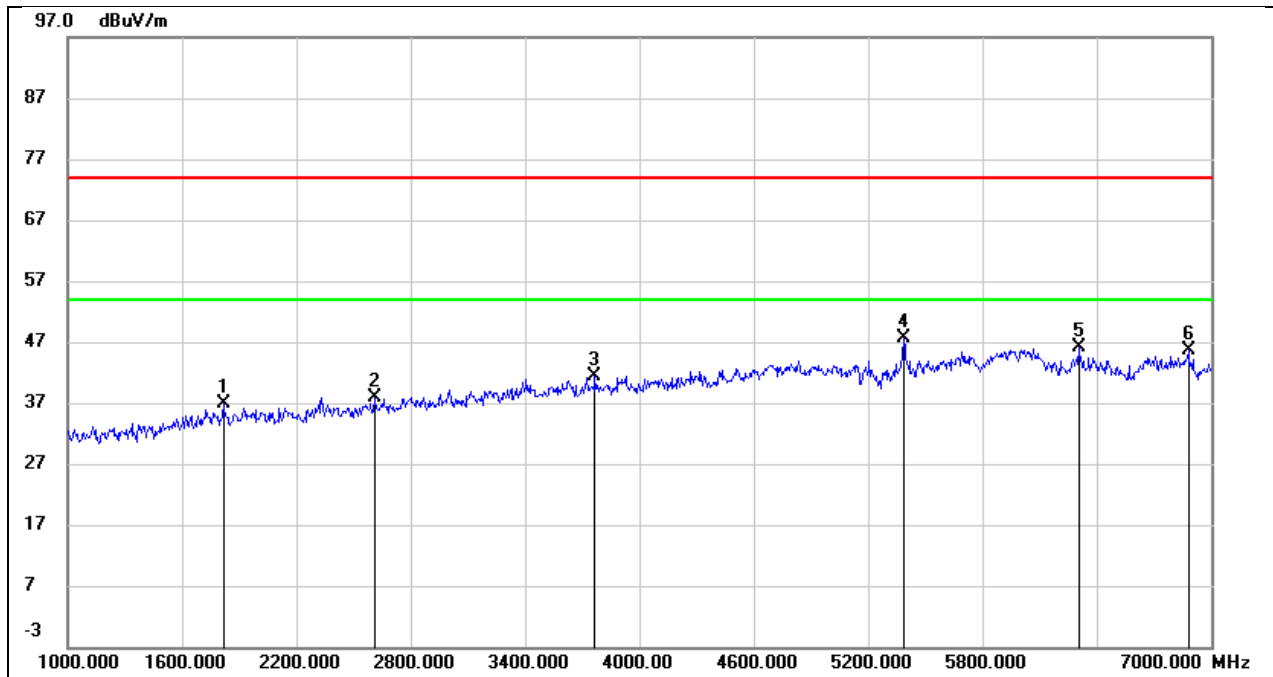

No.	Frequency (MHz)	Reading (dBuV)	Correct (dB/m)	Result (dBuV/m)	Limit (dBuV/m)	Margin (dB)	Remark
1	1816.000	46.15	-9.37	36.78	74.00	-37.22	peak
2	2608.000	44.69	-6.82	37.87	74.00	-36.13	peak
3	3766.000	43.31	-1.84	41.47	74.00	-32.53	peak
4	5386.000	43.48	4.06	47.54	74.00	-26.46	peak
5	6304.000	39.27	6.95	46.22	74.00	-27.78	peak
6	6880.000	38.09	7.42	45.51	74.00	-28.49	peak

Test Mode:	802.11a 20	Frequency(MHz):	5320
Polarity:	Horizontal	Test Voltage:	AC 120V_60Hz

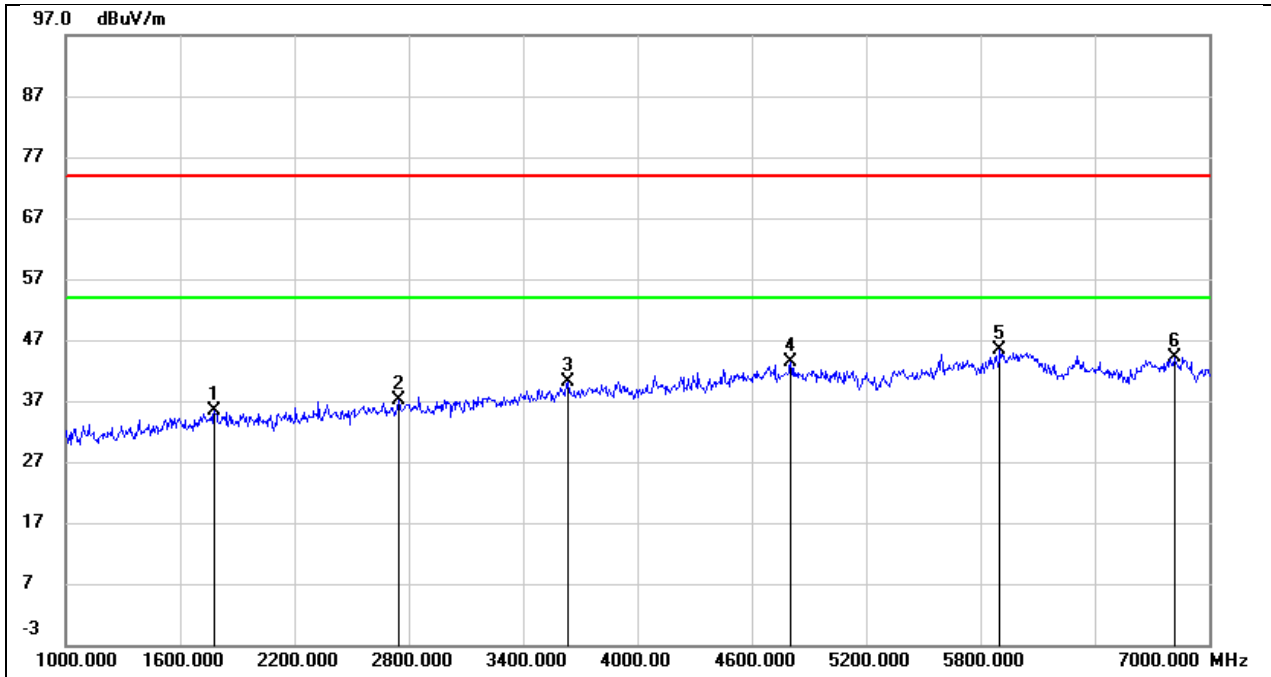

No.	Frequency (MHz)	Reading (dBuV)	Correct (dB/m)	Result (dBuV/m)	Limit (dBuV/m)	Margin (dB)	Remark
1	1780.000	45.41	-10.09	35.32	74.00	-38.68	peak
2	2746.000	44.19	-7.14	37.05	74.00	-36.95	peak
3	3634.000	43.33	-3.21	40.12	74.00	-33.88	peak
4	4804.000	42.42	0.89	43.31	74.00	-30.69	peak
5	5902.000	40.19	5.08	45.27	74.00	-28.73	peak
6	6820.000	37.47	6.59	44.06	74.00	-29.94	peak

Test Mode:	802.11a 20	Frequency(MHz):	5320
Polarity:	Vertical	Test Voltage:	AC 120V_60Hz

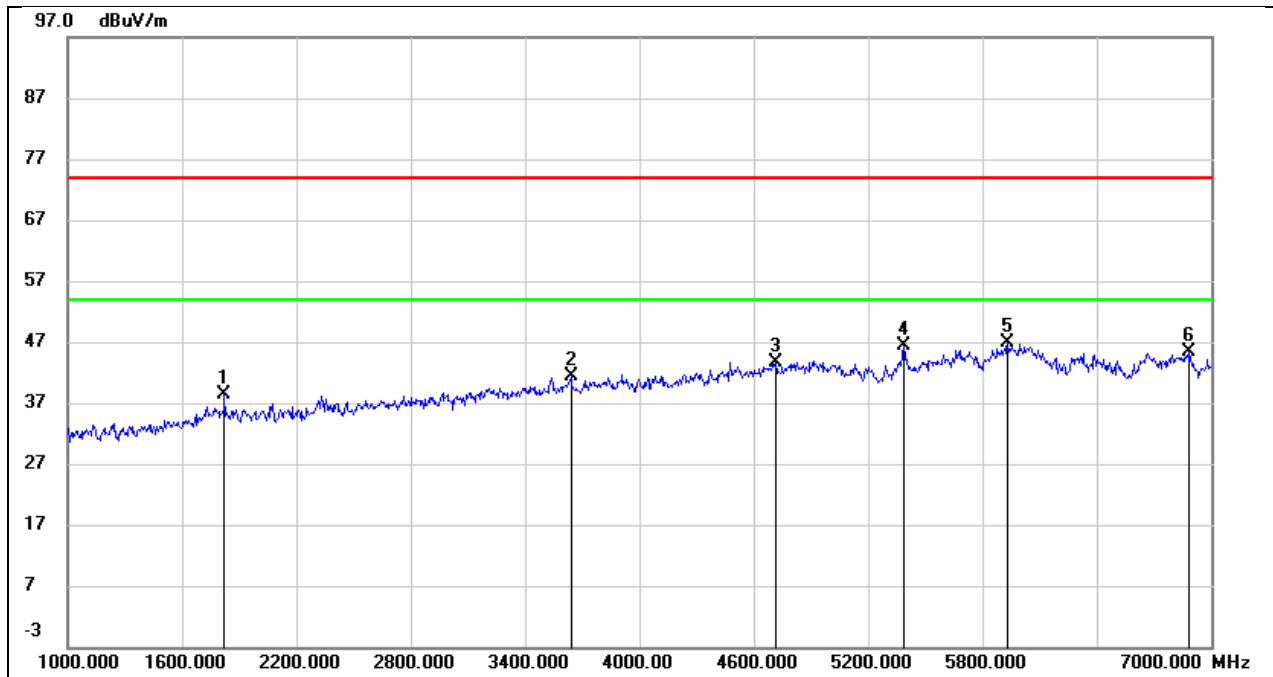

No.	Frequency (MHz)	Reading (dBuV)	Correct (dB/m)	Result (dBuV/m)	Limit (dBuV/m)	Margin (dB)	Remark
1	1822.000	47.77	-9.37	38.40	74.00	-35.60	peak
2	3640.000	43.61	-2.17	41.44	74.00	-32.56	peak
3	4714.000	42.18	1.56	43.74	74.00	-30.26	peak
4	5386.000	42.40	4.06	46.46	74.00	-27.54	peak
5	5932.000	40.48	6.28	46.76	74.00	-27.24	peak
6	6880.000	37.99	7.42	45.41	74.00	-28.59	peak

Test Mode:	802.11a 20	Frequency(MHz):	5500
Polarity:	Horizontal	Test Voltage:	AC 120V_60Hz

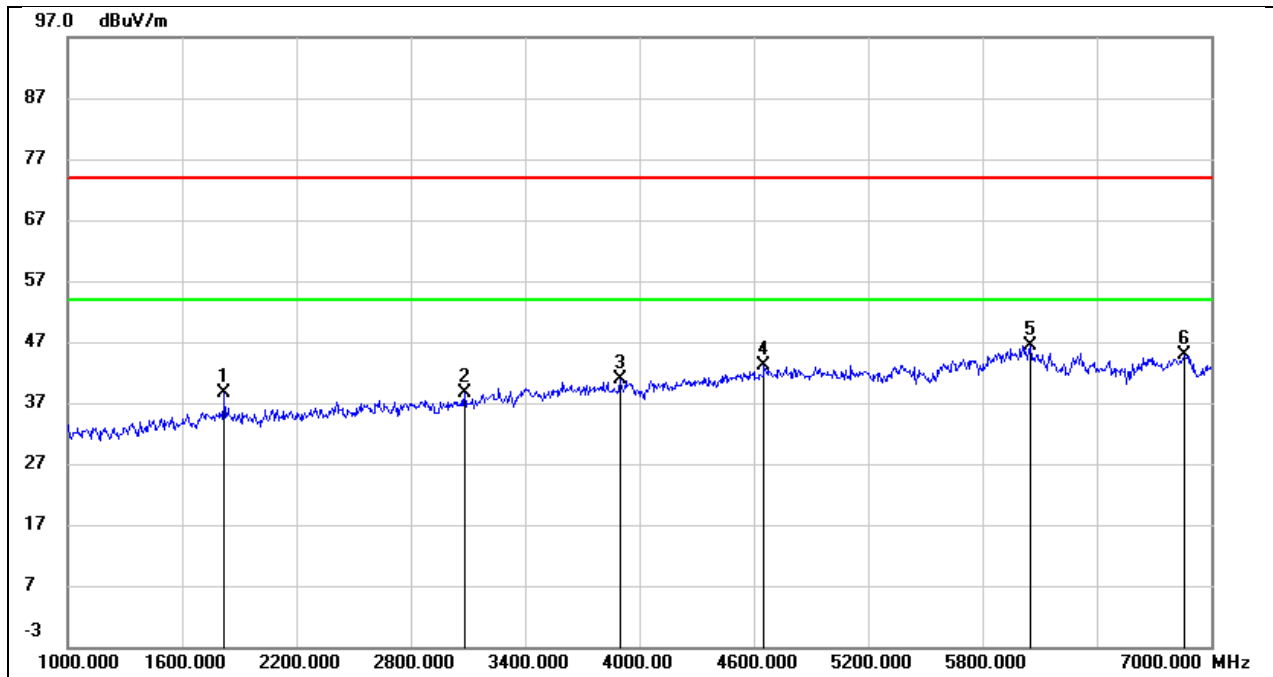

No.	Frequency (MHz)	Reading (dBuV)	Correct (dB/m)	Result (dBuV/m)	Limit (dBuV/m)	Margin (dB)	Remark
1	1822.000	48.65	-9.98	38.67	74.00	-35.33	peak
2	3082.000	44.14	-5.63	38.51	74.00	-35.49	peak
3	3898.000	43.43	-2.60	40.83	74.00	-33.17	peak
4	4654.000	42.90	0.30	43.20	74.00	-30.80	peak
5	6052.000	40.61	5.82	46.43	74.00	-27.57	peak
6	6862.000	38.32	6.56	44.88	74.00	-29.12	peak

Test Mode:	802.11a 20	Frequency(MHz):	5500
Polarity:	Vertical	Test Voltage:	AC 120V_60Hz

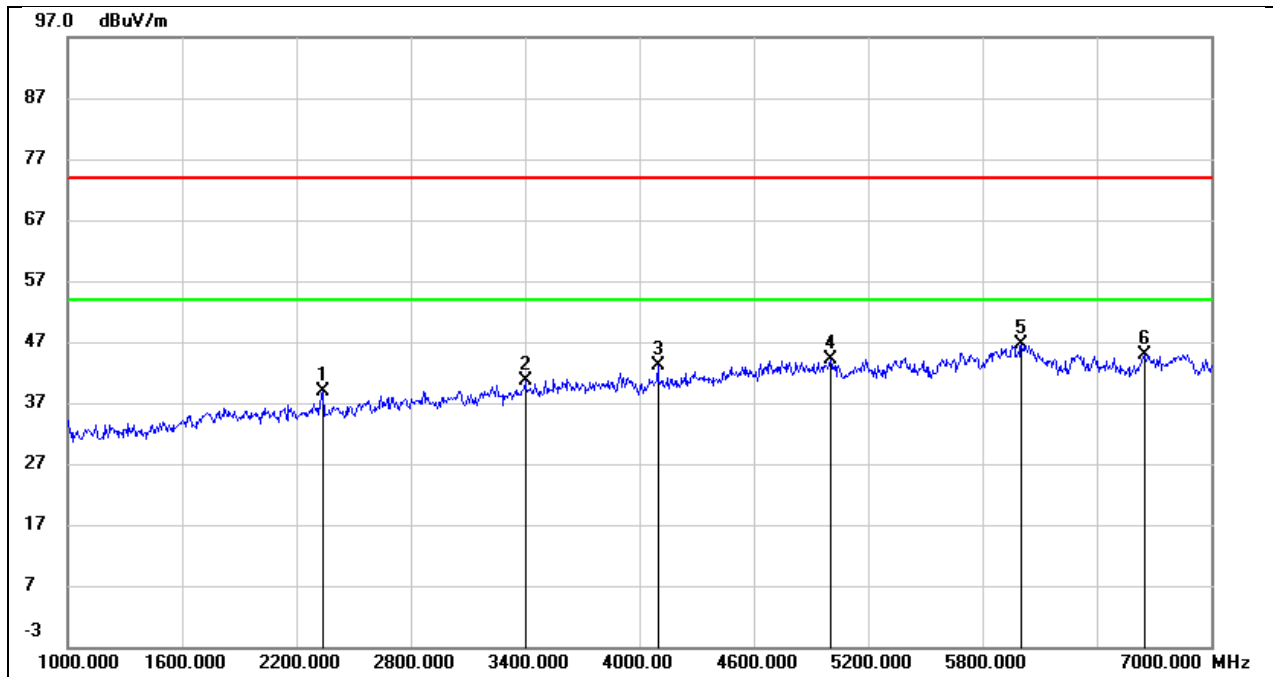

No.	Frequency (MHz)	Reading (dBuV)	Correct (dB/m)	Result (dBuV/m)	Limit (dBuV/m)	Margin (dB)	Remark
1	2338.000	46.75	-7.99	38.76	74.00	-35.24	peak
2	3400.000	43.76	-3.15	40.61	74.00	-33.39	peak
3	4096.000	44.11	-1.00	43.11	74.00	-30.89	peak
4	5002.000	41.20	3.00	44.20	74.00	-29.80	peak
5	6004.000	39.90	6.64	46.54	74.00	-27.46	peak
6	6652.000	37.94	7.04	44.98	74.00	-29.02	peak

Test Mode:	802.11a 20	Frequency(MHz):	5580
Polarity:	Horizontal	Test Voltage:	AC 120V_60Hz

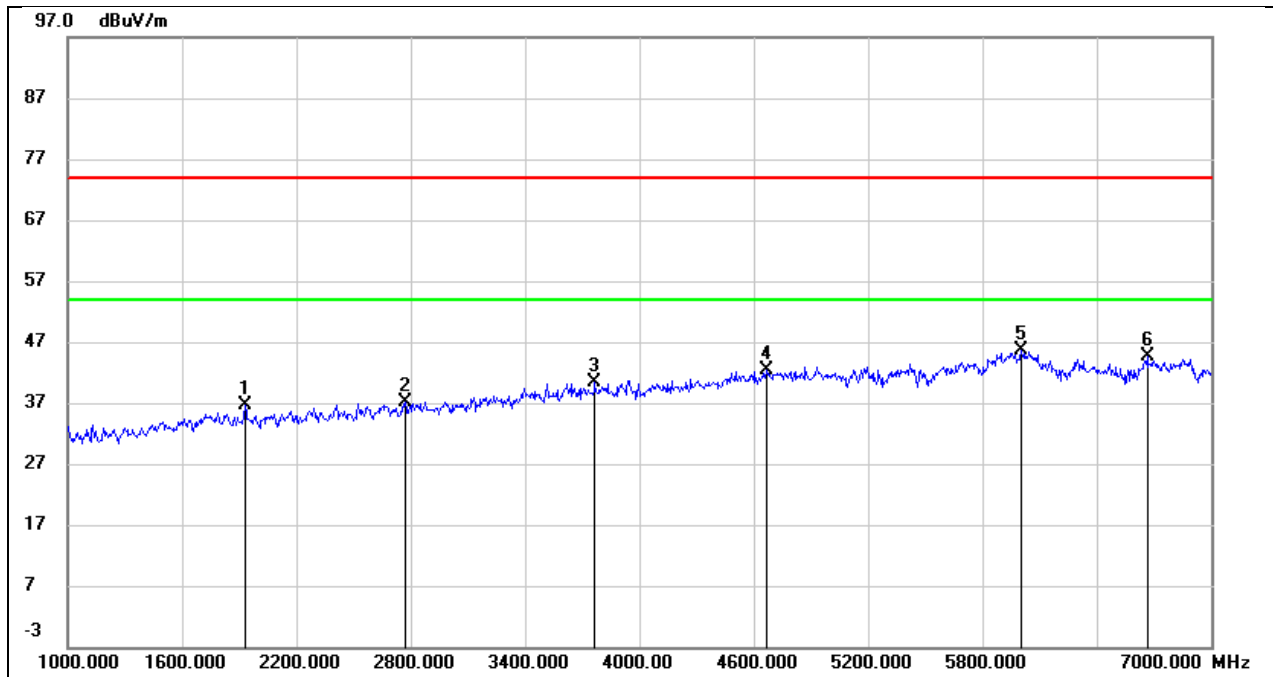

No.	Frequency (MHz)	Reading (dBuV)	Correct (dB/m)	Result (dBuV/m)	Limit (dBuV/m)	Margin (dB)	Remark
1	1930.000	46.61	-10.04	36.57	74.00	-37.43	peak
2	2770.000	44.13	-7.05	37.08	74.00	-36.92	peak
3	3766.000	43.15	-2.89	40.26	74.00	-33.74	peak
4	4666.000	42.15	0.35	42.50	74.00	-31.50	peak
5	6004.000	39.98	5.64	45.62	74.00	-28.38	peak
6	6664.000	38.44	6.25	44.69	74.00	-29.31	peak



Test Mode:	802.11a 20	Frequency(MHz):	5580
Polarity:	Vertical	Test Voltage:	AC 120V_60Hz

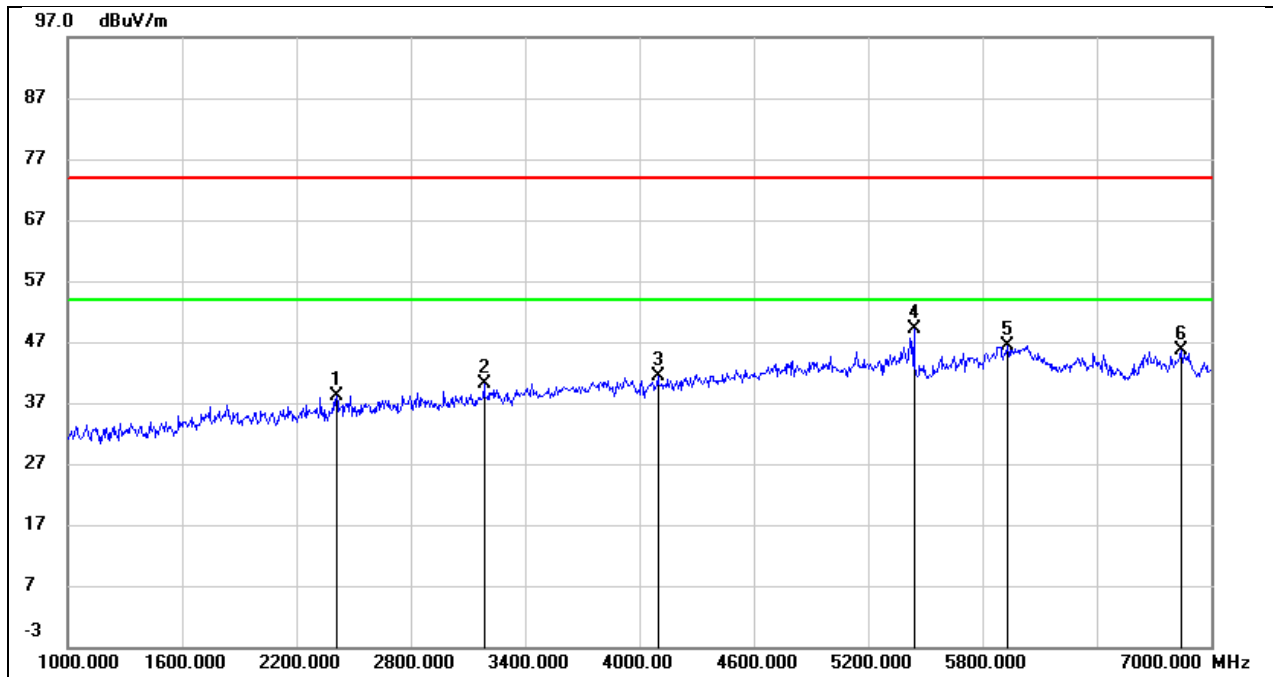

No.	Frequency (MHz)	Reading (dBuV)	Correct (dB/m)	Result (dBuV/m)	Limit (dBuV/m)	Margin (dB)	Remark
1	2410.000	45.79	-7.73	38.06	74.00	-35.94	peak
2	3184.000	44.01	-3.95	40.06	74.00	-33.94	peak
3	4096.000	42.29	-1.00	41.29	74.00	-32.71	peak
4	5440.000	44.94	4.25	49.19	74.00	-24.81	peak
5	5932.000	40.11	6.28	46.39	74.00	-27.61	peak
6	6844.000	38.07	7.45	45.52	74.00	-28.48	peak

Test Mode:	802.11a 20	Frequency(MHz):	5700
Polarity:	Horizontal	Test Voltage:	AC 120V_60Hz

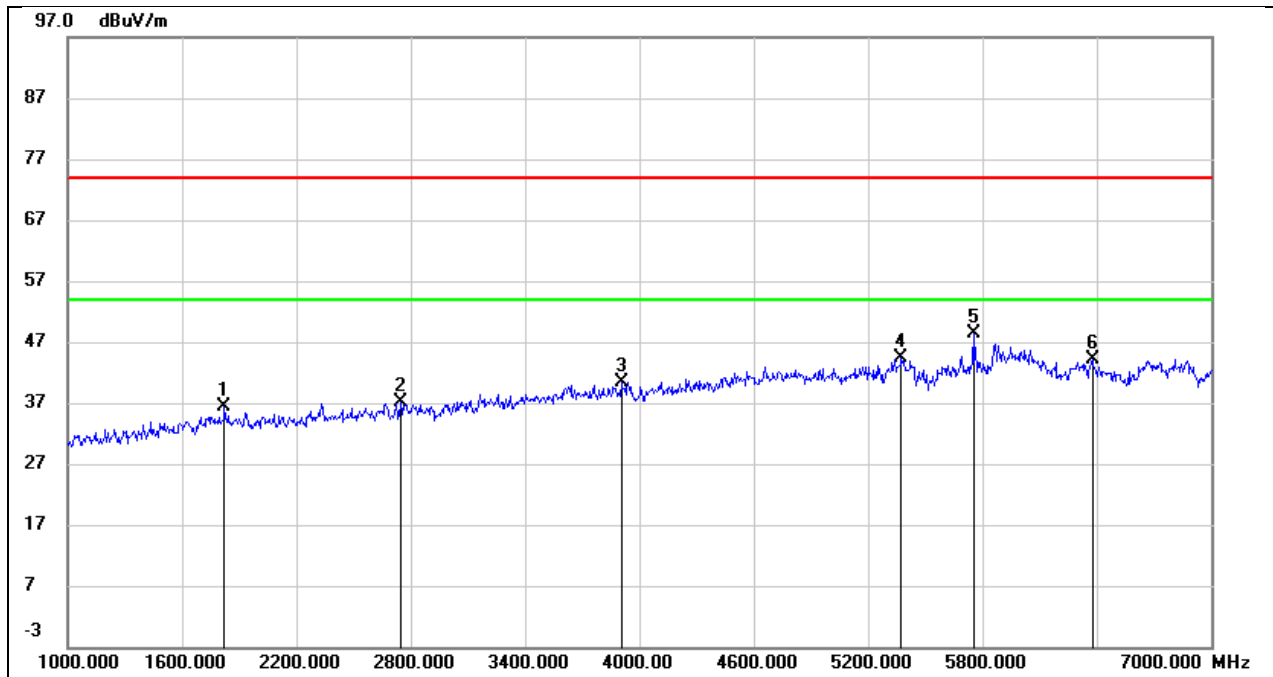

No.	Frequency (MHz)	Reading (dBuV)	Correct (dB/m)	Result (dBuV/m)	Limit (dBuV/m)	Margin (dB)	Remark
1	1822.000	46.24	-9.98	36.26	74.00	-37.74	peak
2	2746.000	44.24	-7.14	37.10	74.00	-36.90	peak
3	3904.000	42.90	-2.60	40.30	74.00	-33.70	peak
4	5374.000	41.54	2.80	44.34	74.00	-29.66	peak
5	5752.000	44.05	4.29	48.34	74.00	-25.66	peak
6	6376.000	38.32	5.86	44.18	74.00	-29.82	peak

Test Mode:	802.11a 20	Frequency(MHz):	5700
Polarity:	Vertical	Test Voltage:	AC 120V_60Hz

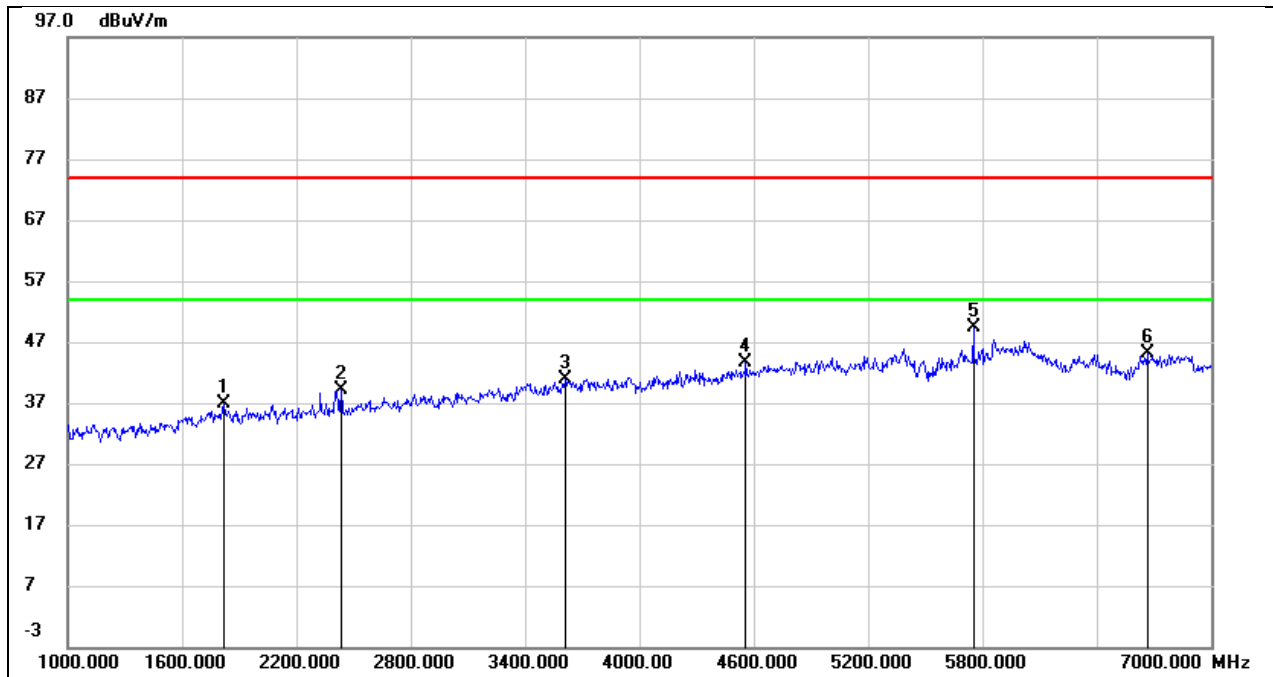

No.	Frequency (MHz)	Reading (dBuV)	Correct (dB/m)	Result (dBuV/m)	Limit (dBuV/m)	Margin (dB)	Remark
1	1822.000	46.36	-9.37	36.99	74.00	-37.01	peak
2	2434.000	46.66	-7.65	39.01	74.00	-34.99	peak
3	3610.000	43.18	-2.25	40.93	74.00	-33.07	peak
4	4558.000	42.73	0.80	43.53	74.00	-30.47	peak
5	5752.000	44.05	5.39	49.44	74.00	-24.56	peak
6	6664.000	38.04	7.09	45.13	74.00	-28.87	peak

Test Mode:	802.11a 20	Frequency(MHz):	5720
Polarity:	Horizontal	Test Voltage:	AC 120V_60Hz

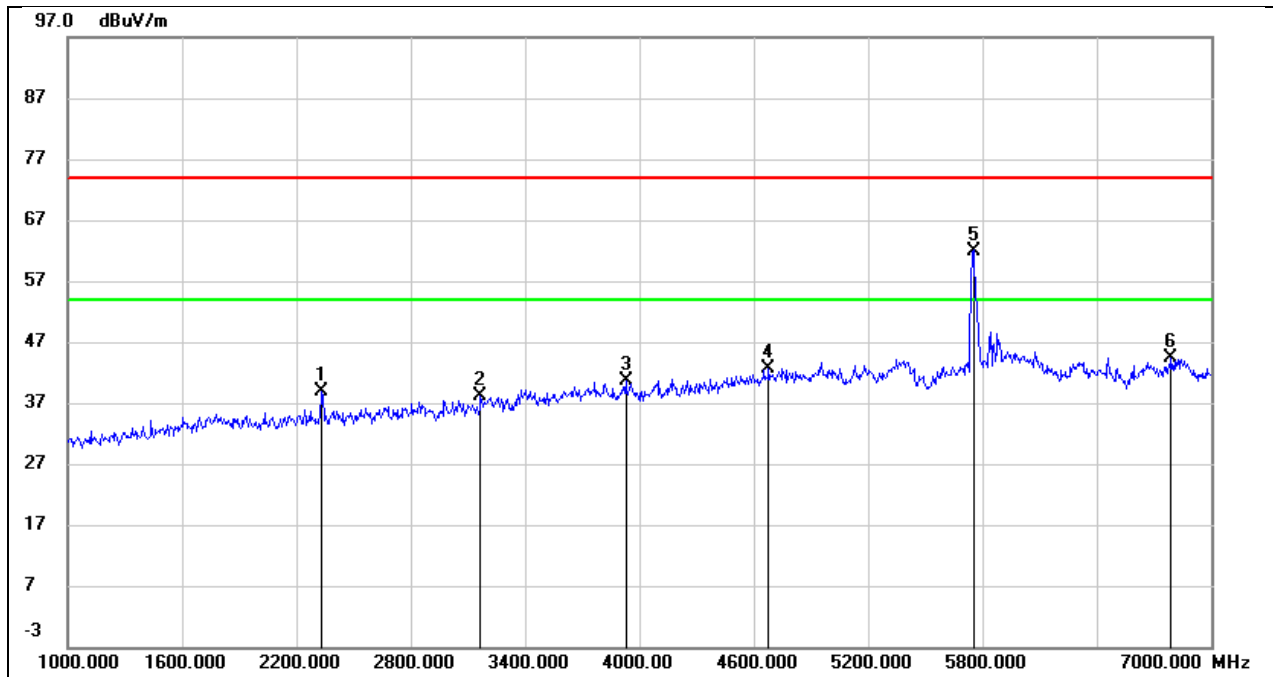

No.	Frequency (MHz)	Reading (dBuV)	Correct (dB/m)	Result (dBuV/m)	Limit (dBuV/m)	Margin (dB)	Remark
1	2332.000	47.65	-8.85	38.80	74.00	-35.20	peak
2	3166.000	43.36	-5.24	38.12	74.00	-35.88	peak
3	3928.000	43.11	-2.55	40.56	74.00	-33.44	peak
4	4678.000	42.25	0.38	42.63	74.00	-31.37	peak
5	5720.000	57.71	4.29	62.00	/	/	Fundamental
6	6790.000	37.76	6.58	44.34	74.00	-29.66	peak

Test Mode:	802.11a 20	Frequency(MHz):	5720
Polarity:	Vertical	Test Voltage:	AC 120V_60Hz

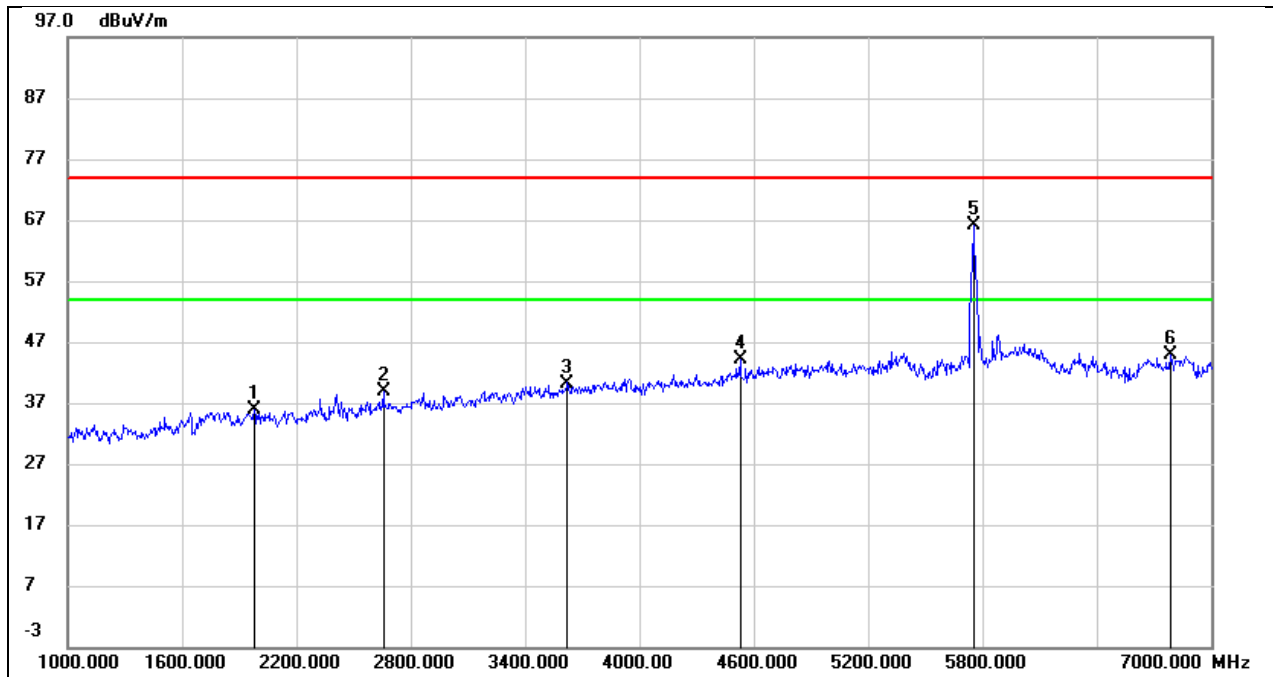

No.	Frequency (MHz)	Reading (dBuV)	Correct (dB/m)	Result (dBuV/m)	Limit (dBuV/m)	Margin (dB)	Remark
1	1978.000	45.21	-9.21	36.00	74.00	-38.00	peak
2	2656.000	45.46	-6.57	38.89	74.00	-35.11	peak
3	3622.000	42.47	-2.22	40.25	74.00	-33.75	peak
4	4528.000	43.39	0.62	44.01	74.00	-29.99	peak
5	5720.000	60.85	5.39	66.24	/	/	Fundamental
6	6784.000	37.56	7.42	44.98	74.00	-29.02	peak

Test Mode:	802.11a 20	Frequency(MHz):	5745
Polarity:	Horizontal	Test Voltage:	AC 120V_60Hz

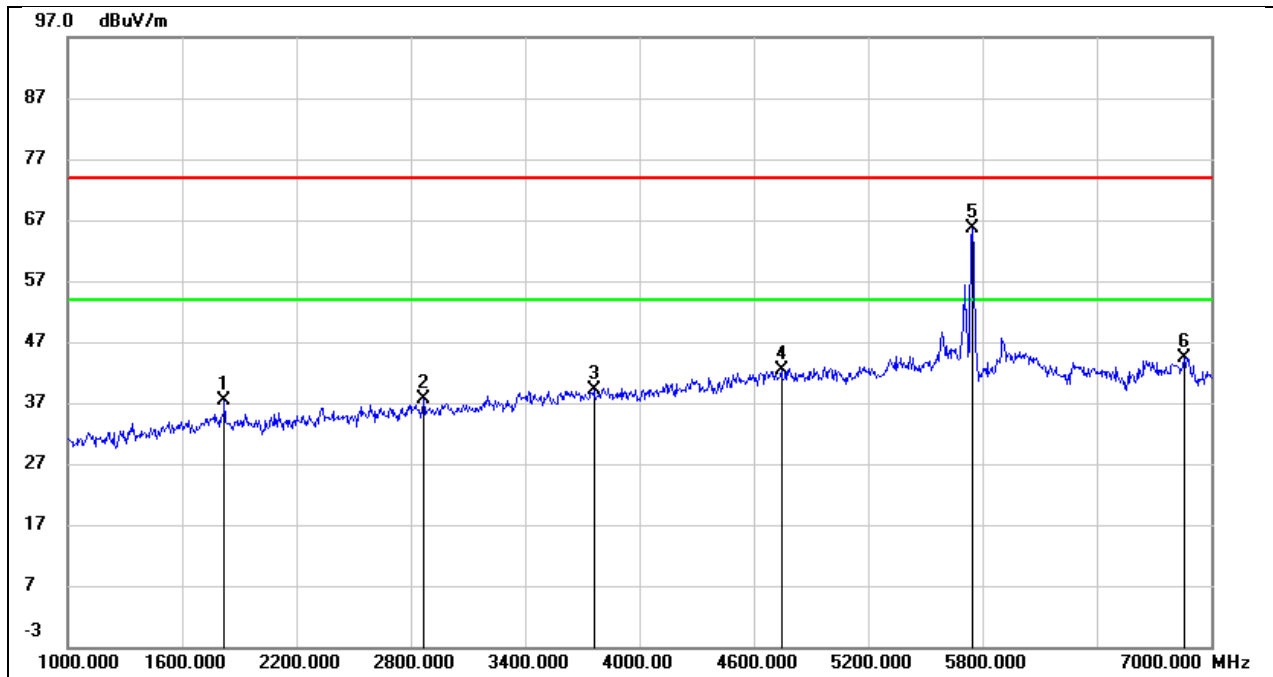

No.	Frequency (MHz)	Reading (dBuV)	Correct (dB/m)	Result (dBuV/m)	Limit (dBuV/m)	Margin (dB)	Remark
1	1822.000	47.42	-9.98	37.44	74.00	-36.56	peak
2	2866.000	44.27	-6.62	37.65	74.00	-36.35	peak
3	3760.000	42.09	-2.90	39.19	74.00	-34.81	peak
4	4744.000	41.61	0.65	42.26	74.00	-31.74	peak
5	5745.000	61.29	4.26	65.55	/	/	Fundamental
6	6856.000	37.93	6.56	44.49	74.00	-29.51	peak

Test Mode:	802.11a 20	Frequency(MHz):	5745
Polarity:	Vertical	Test Voltage:	AC 120V_60Hz

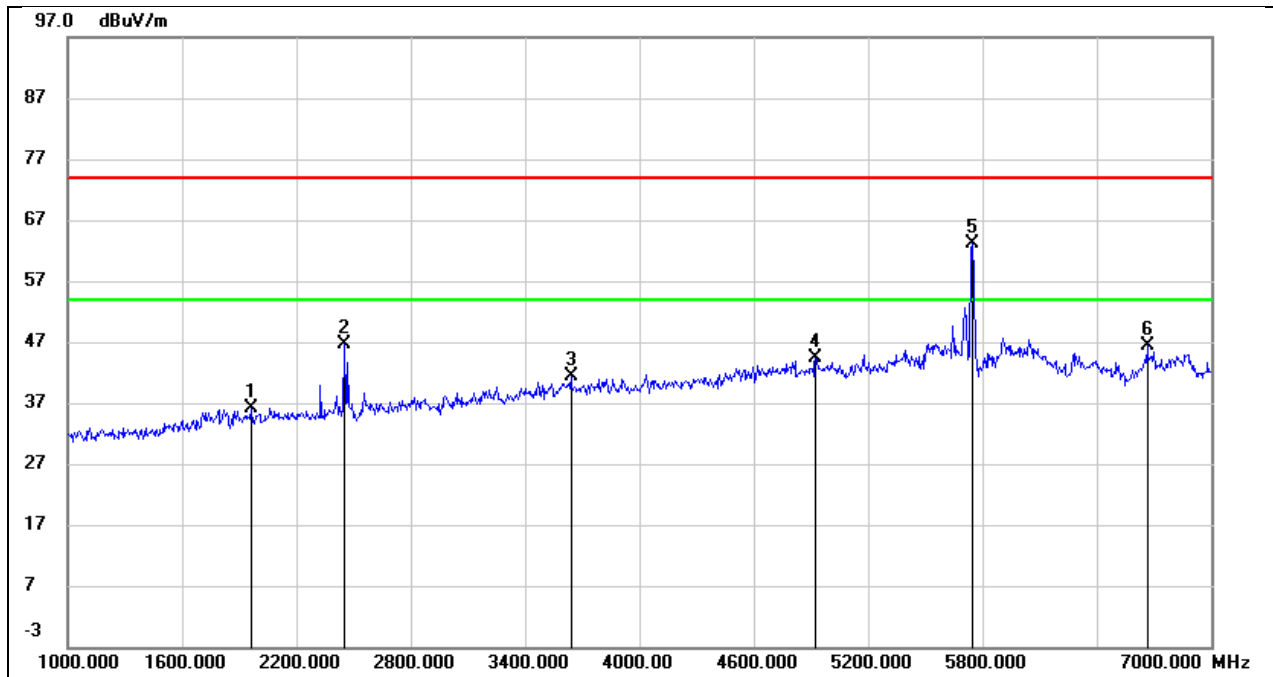

No.	Frequency (MHz)	Reading (dBuV)	Correct (dB/m)	Result (dBuV/m)	Limit (dBuV/m)	Margin (dB)	Remark
1	1960.000	45.29	-9.24	36.05	74.00	-37.95	peak
2	2452.000	54.24	-7.59	46.65	74.00	-27.35	peak
3	3640.000	43.51	-2.17	41.34	74.00	-32.66	peak
4	4924.000	41.83	2.60	44.43	74.00	-29.57	peak
5	5745.000	57.80	5.37	63.17	/	/	Fundamental
6	6664.000	39.17	7.09	46.26	74.00	-27.74	peak

Test Mode:	802.11a 20	Frequency(MHz):	5785
Polarity:	Horizontal	Test Voltage:	AC 120V_60Hz

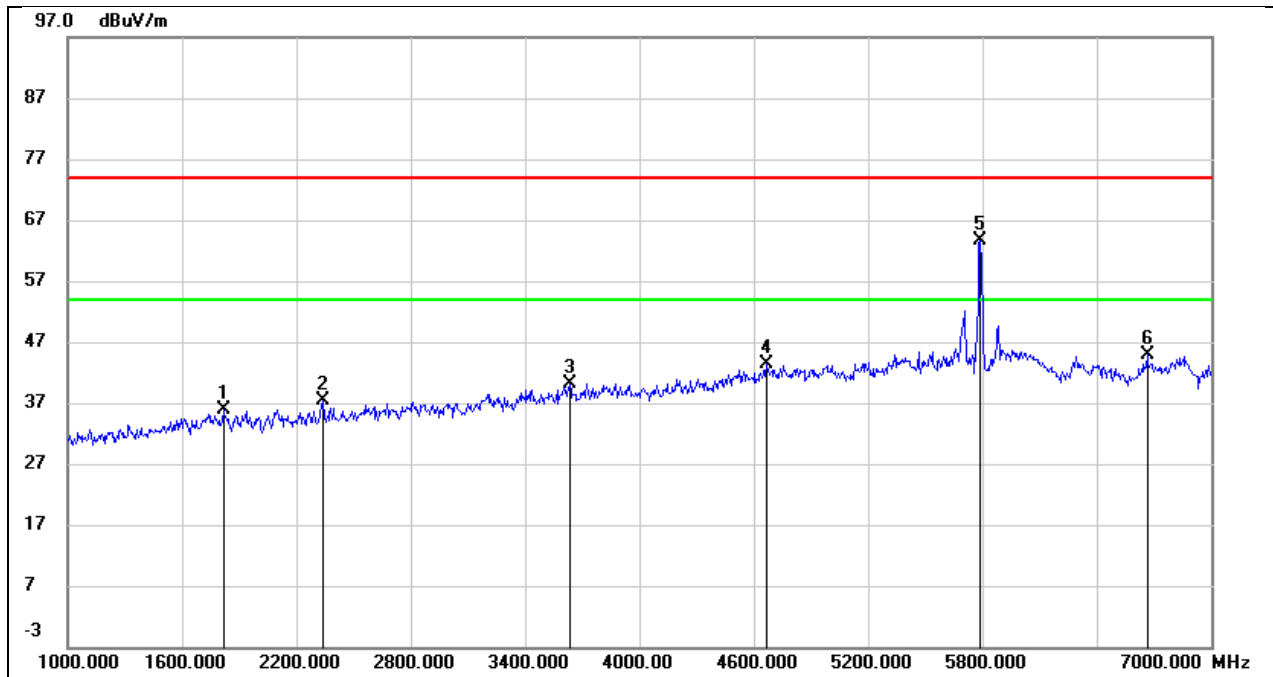

No.	Frequency (MHz)	Reading (dBuV)	Correct (dB/m)	Result (dBuV/m)	Limit (dBuV/m)	Margin (dB)	Remark
1	1816.000	45.85	-9.97	35.88	74.00	-38.12	peak
2	2338.000	46.08	-8.82	37.26	74.00	-36.74	peak
3	3634.000	43.23	-3.21	40.02	74.00	-33.98	peak
4	4666.000	43.02	0.35	43.37	74.00	-30.63	peak
5	5785.000	59.27	4.46	63.73	/	/	Fundamental
6	6664.000	38.58	6.25	44.83	74.00	-29.17	peak



Test Mode:	802.11a 20	Frequency(MHz):	5785
Polarity:	Vertical	Test Voltage:	AC 120V_60Hz

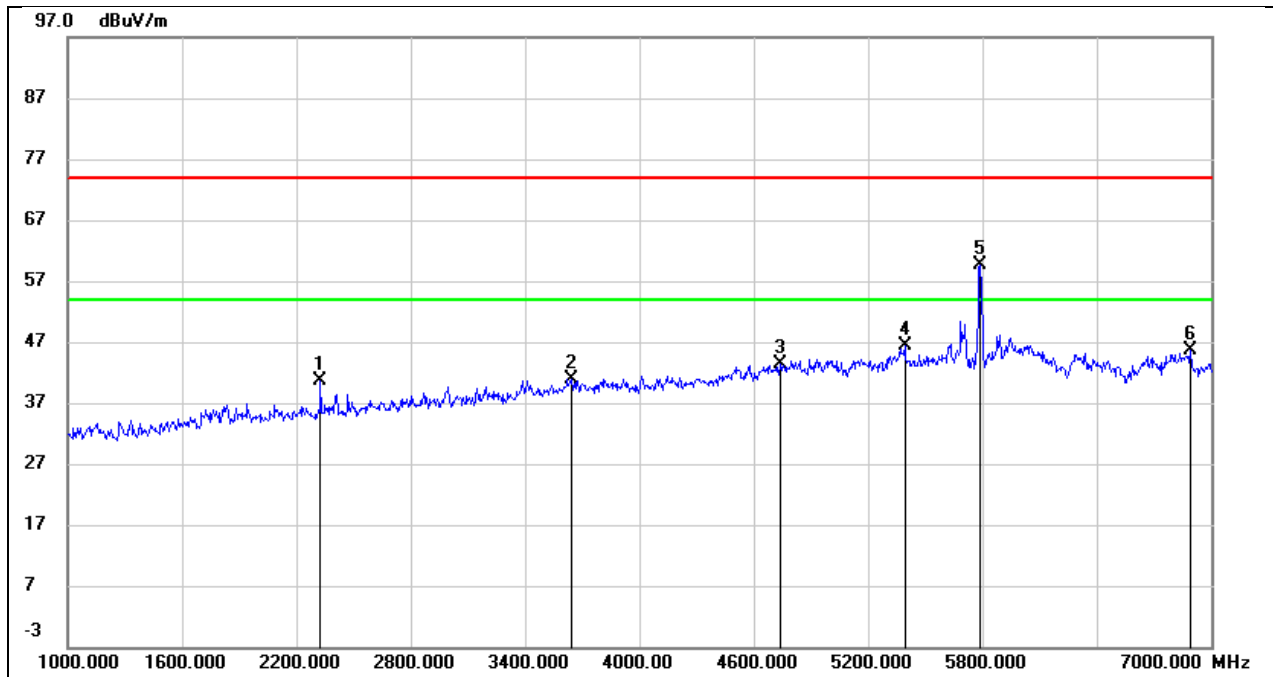

No.	Frequency (MHz)	Reading (dBuV)	Correct (dB/m)	Result (dBuV/m)	Limit (dBuV/m)	Margin (dB)	Remark
1	2326.000	48.69	-8.03	40.66	74.00	-33.34	peak
2	3646.000	43.14	-2.16	40.98	74.00	-33.02	peak
3	4738.000	41.71	1.66	43.37	74.00	-30.63	peak
4	5392.000	42.19	4.09	46.28	74.00	-27.72	peak
5	5785.000	53.99	5.55	59.54	/	/	Fundamental
6	6892.000	38.12	7.42	45.54	74.00	-28.46	peak

Test Mode:	802.11a 20	Frequency(MHz):	5825
Polarity:	Horizontal	Test Voltage:	AC 120V_60Hz

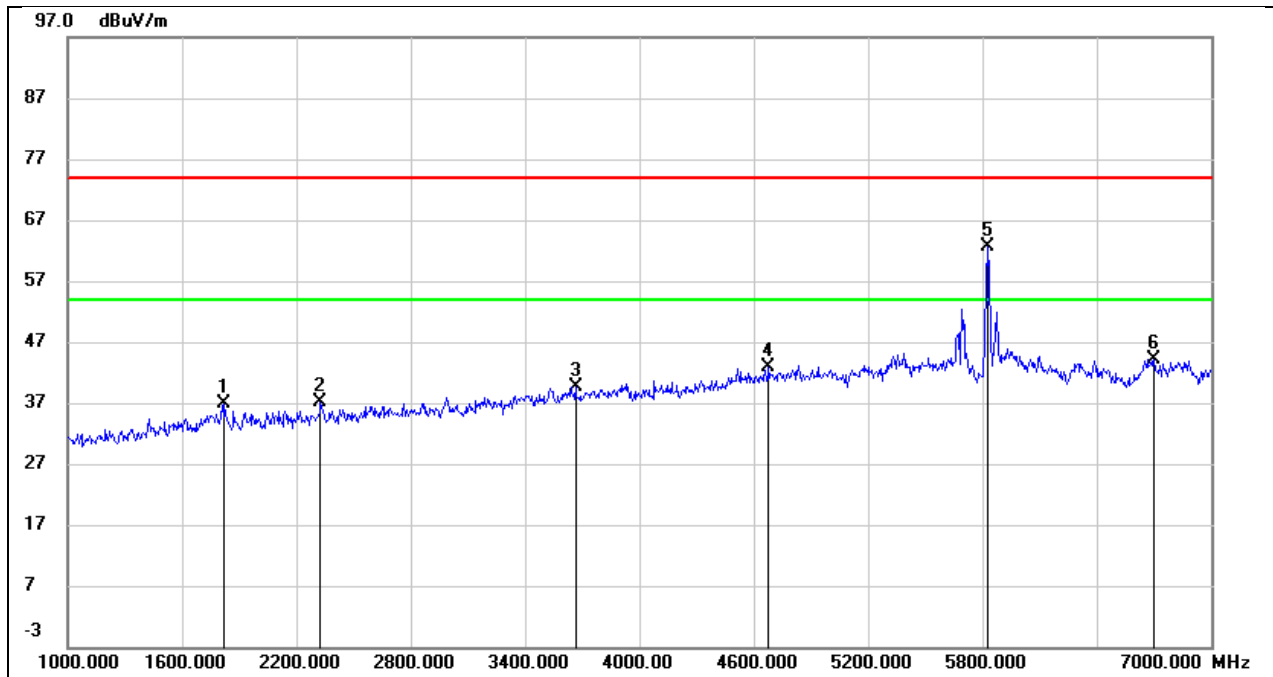

No.	Frequency (MHz)	Reading (dBuV)	Correct (dB/m)	Result (dBuV/m)	Limit (dBuV/m)	Margin (dB)	Remark
1	1822.000	46.84	-9.98	36.86	74.00	-37.14	peak
2	2326.000	45.96	-8.87	37.09	74.00	-36.91	peak
3	3664.000	42.76	-3.13	39.63	74.00	-34.37	peak
4	4678.000	42.56	0.38	42.94	74.00	-31.06	peak
5	5825.000	57.88	4.68	62.56	/	/	Fundamental
6	6700.000	37.79	6.35	44.14	74.00	-29.86	peak

Test Mode:	802.11a 20	Frequency(MHz):	5825
Polarity:	Vertical	Test Voltage:	AC 120V_60Hz

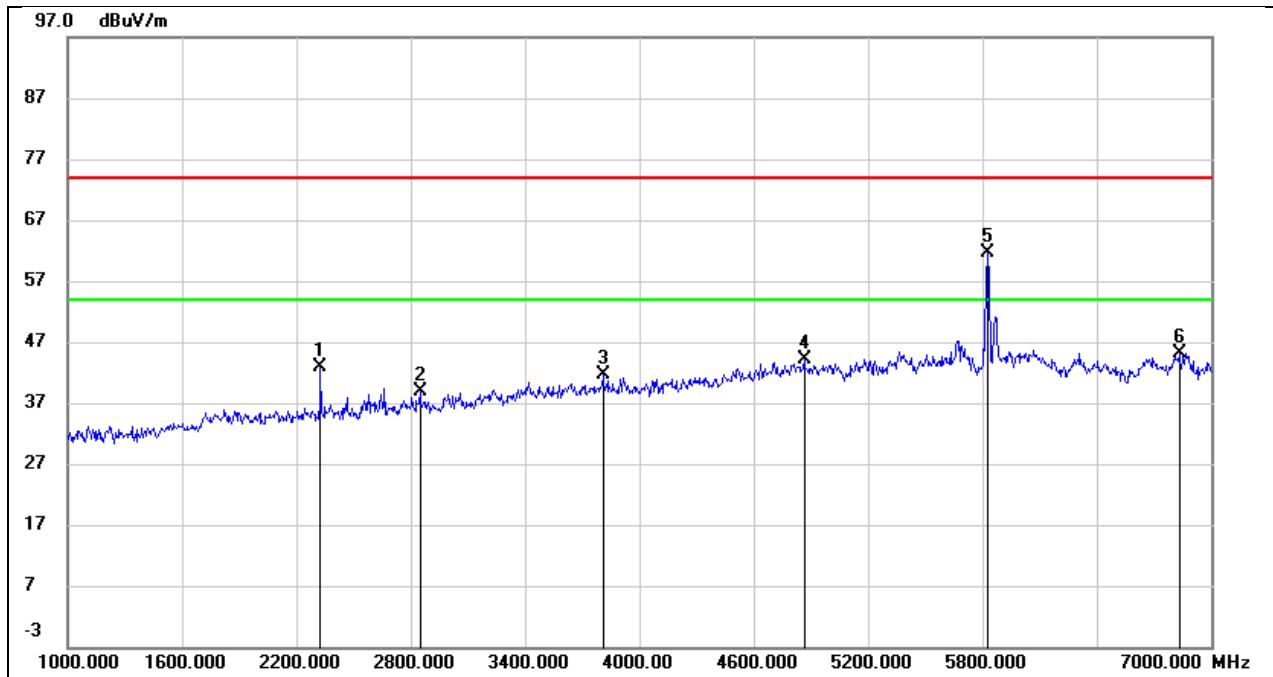

No.	Frequency (MHz)	Reading (dBuV)	Correct (dB/m)	Result (dBuV/m)	Limit (dBuV/m)	Margin (dB)	Remark
1	2326.000	50.83	-8.03	42.80	74.00	-31.20	peak
2	2848.000	44.33	-5.56	38.77	74.00	-35.23	peak
3	3808.000	43.43	-1.73	41.70	74.00	-32.30	peak
4	4864.000	41.88	2.29	44.17	74.00	-29.83	peak
5	5825.000	55.78	5.75	61.53	/	/	Fundamental
6	6832.000	37.75	7.45	45.20	74.00	-28.80	peak

### 8.3. SPURIOUS EMISSIONS(7 GHZ~18 GHZ)

Test Mode:	802.11a 20	Frequency(MHz):	5180
Polarity:	Horizontal	Test Voltage:	AC 120V_60Hz

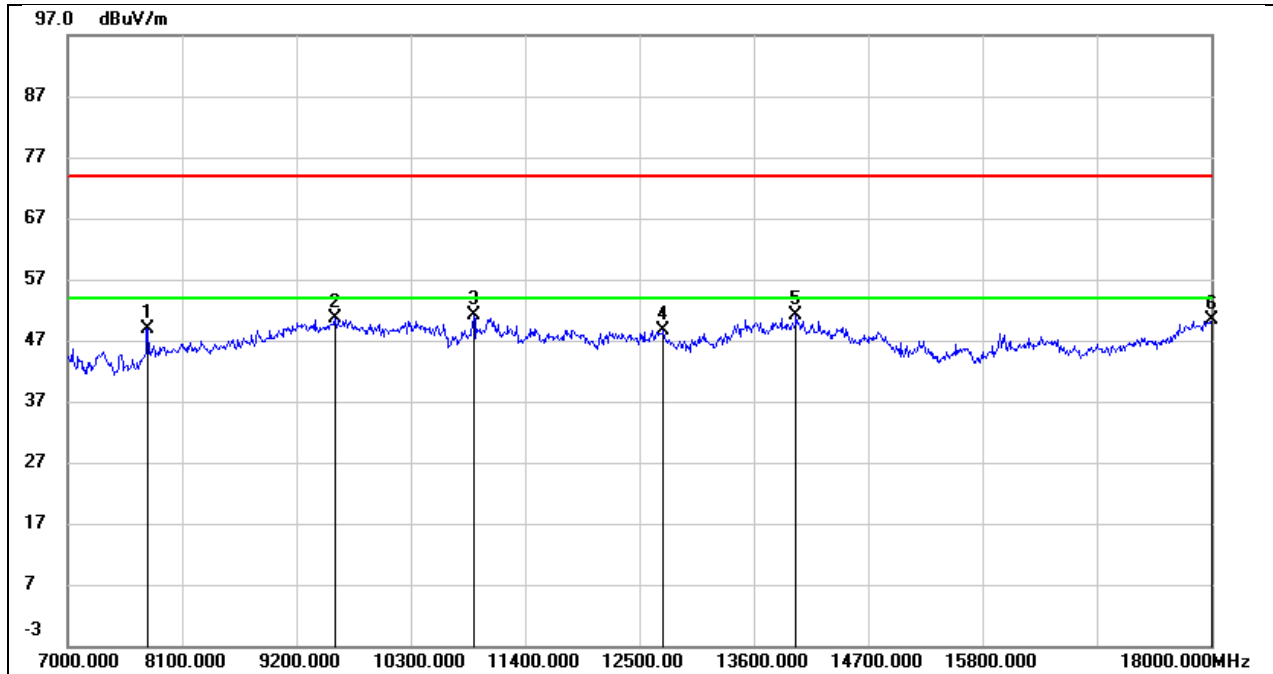

No.	Frequency (MHz)	Reading (dBuV)	Correct (dB/m)	Result (dBuV/m)	Limit (dBuV/m)	Margin (dB)	Remark
1	7770.000	40.88	7.99	48.87	74.00	-25.13	peak
2	9574.000	37.26	13.31	50.57	74.00	-23.43	peak
3	10905.000	36.38	14.75	51.13	74.00	-22.87	peak
4	12731.000	28.95	19.70	48.65	74.00	-25.35	peak
5	14007.000	27.57	23.59	51.16	74.00	-22.84	peak
6	18000.000	20.75	29.61	50.36	74.00	-23.64	peak

Test Mode:	802.11a 20	Frequency(MHz):	5180
Polarity:	Vertical	Test Voltage:	AC 120V_60Hz

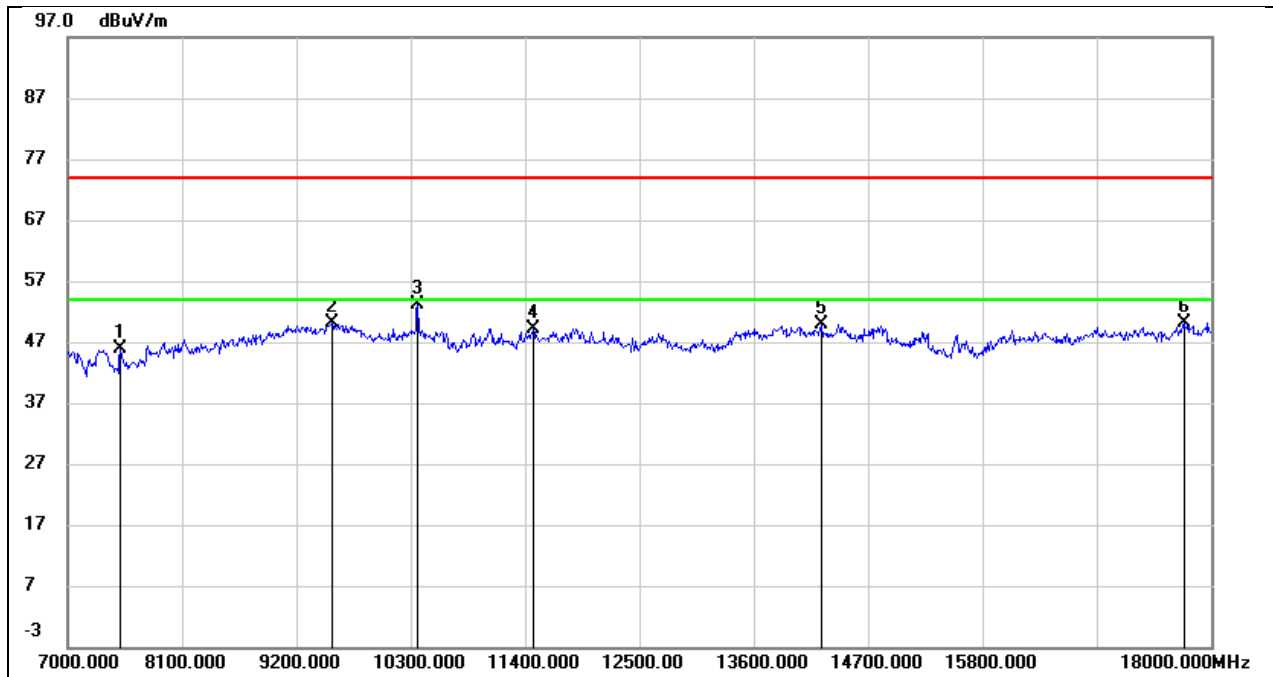

No.	Frequency (MHz)	Reading (dBuV)	Correct (dB/m)	Result (dBuV/m)	Limit (dBuV/m)	Margin (dB)	Remark
1	7506.000	37.61	8.34	45.95	74.00	-28.05	peak
2	9541.000	37.06	13.04	50.10	74.00	-23.90	peak
3	10366.000	40.08	12.99	53.07	74.00	-20.93	peak
4	11477.000	32.96	16.26	49.22	74.00	-24.78	peak
5	14249.000	28.44	21.54	49.98	74.00	-24.02	peak
6	17736.000	24.24	25.83	50.07	74.00	-23.93	peak

Test Mode:	802.11a 20	Frequency(MHz):	5200
Polarity:	Horizontal	Test Voltage:	AC 120V_60Hz

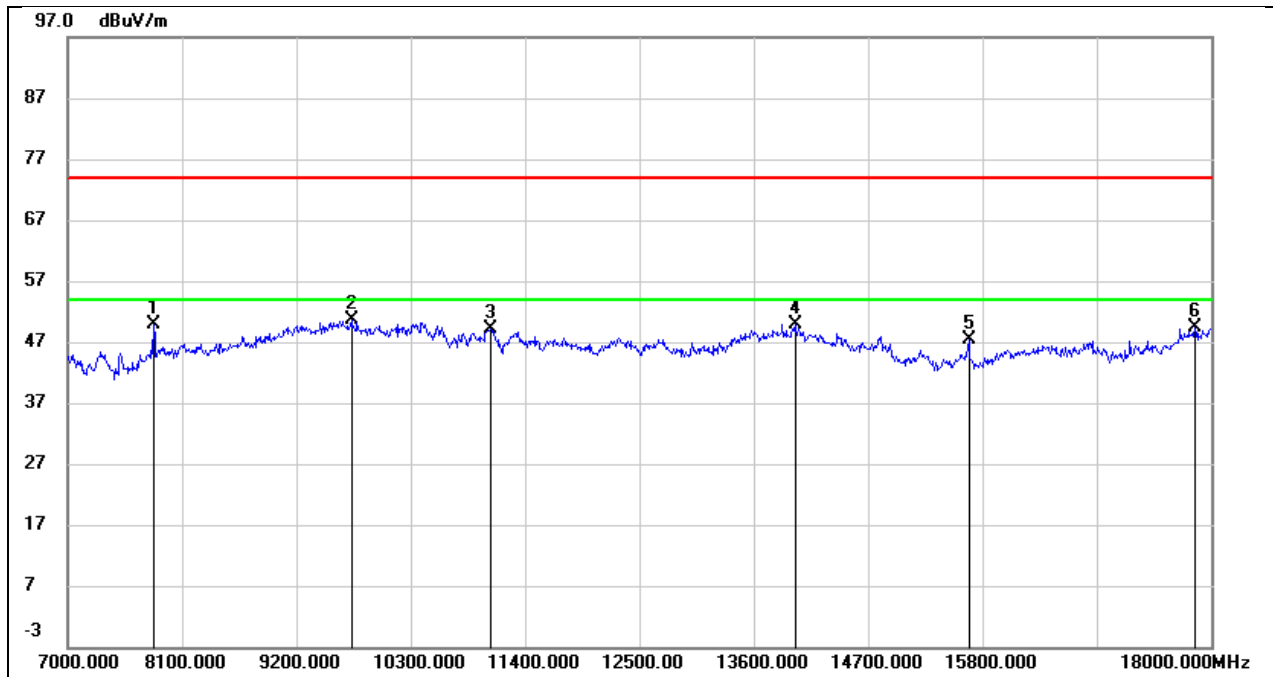

No.	Frequency (MHz)	Reading (dBuV)	Correct (dB/m)	Result (dBuV/m)	Limit (dBuV/m)	Margin (dB)	Remark
1	7825.000	41.93	8.02	49.95	74.00	-24.05	peak
2	9728.000	36.91	13.68	50.59	74.00	-23.41	peak
3	11070.000	33.78	15.44	49.22	74.00	-24.78	peak
4	13996.000	26.38	23.59	49.97	74.00	-24.03	peak
5	15668.000	28.00	19.40	47.40	74.00	-26.60	peak
6	17846.000	21.30	27.97	49.27	74.00	-24.73	peak

Test Mode:	802.11a 20	Frequency(MHz):	5200
Polarity:	Vertical	Test Voltage:	AC 120V_60Hz

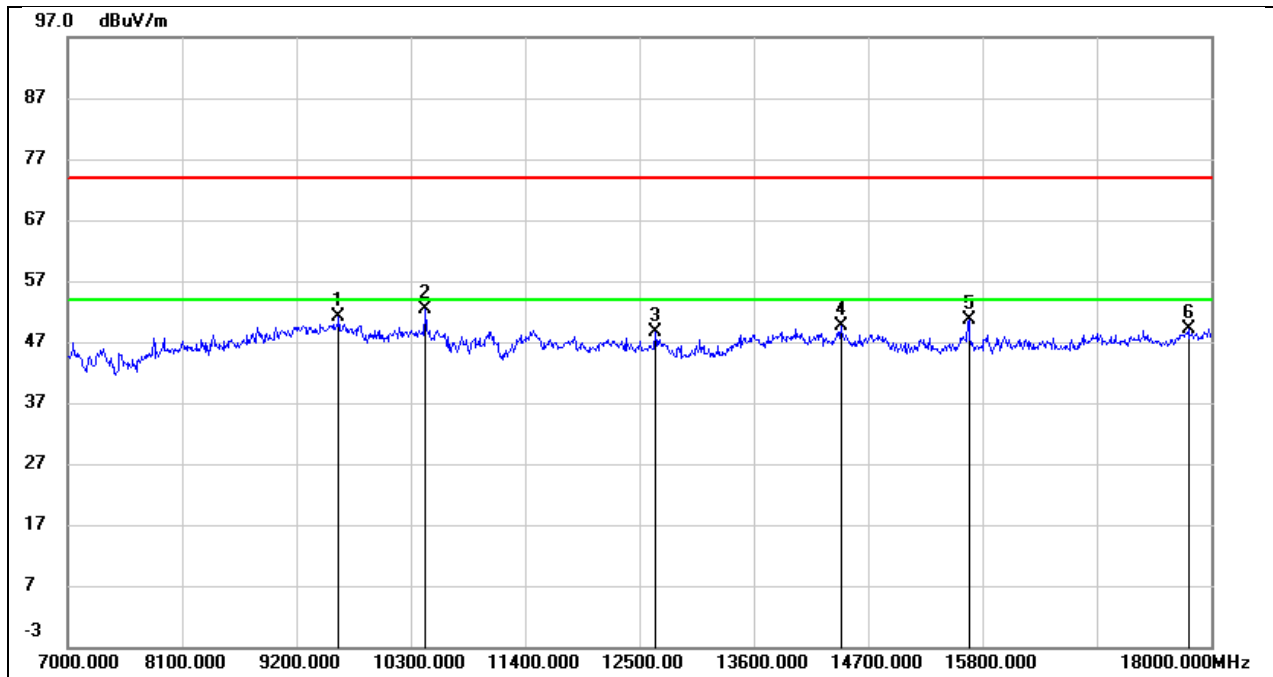

No.	Frequency (MHz)	Reading (dBuV)	Correct (dB/m)	Result (dBuV/m)	Limit (dBuV/m)	Margin (dB)	Remark
1	9607.000	37.73	13.33	51.06	74.00	-22.94	peak
2	10443.000	39.25	13.17	52.42	74.00	-21.58	peak
3	12654.000	30.26	18.39	48.65	74.00	-25.35	peak
4	14436.000	28.70	20.98	49.68	74.00	-24.32	peak
5	15668.000	29.40	21.14	50.54	74.00	-23.46	peak
6	17780.000	23.18	26.06	49.24	74.00	-24.76	peak

Test Mode:	802.11a 20	Frequency(MHz):	5240
Polarity:	Horizontal	Test Voltage:	AC 120V_60Hz

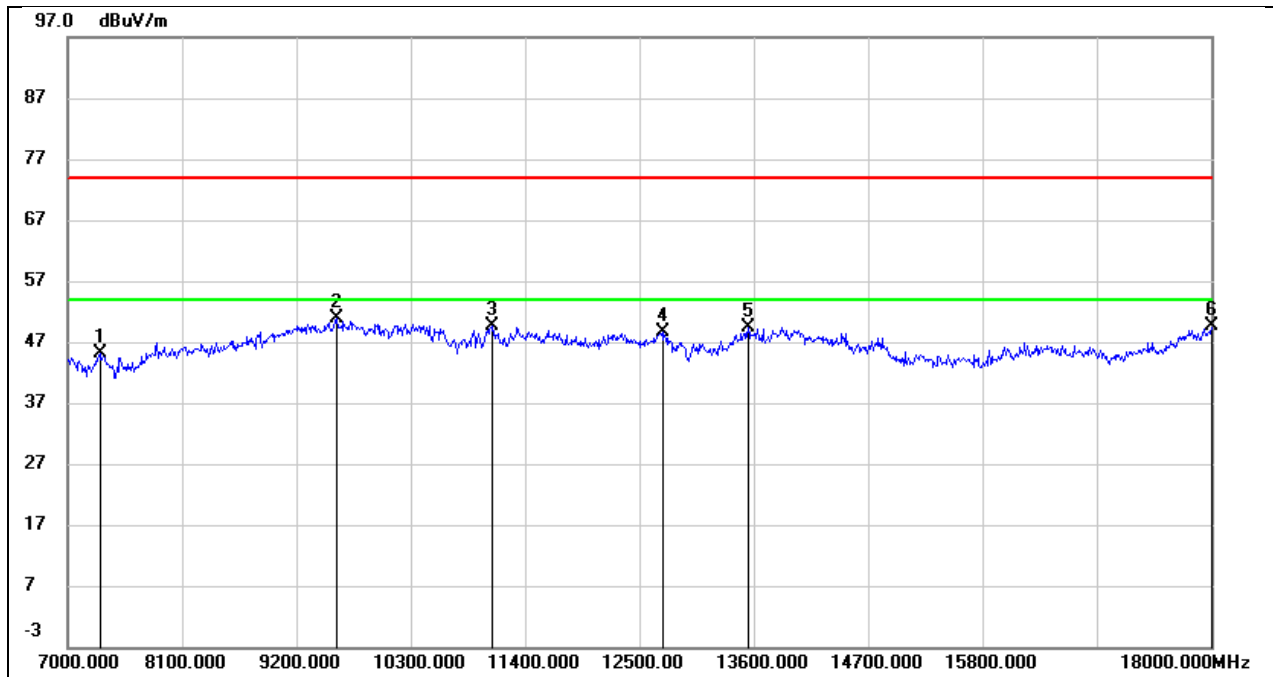

No.	Frequency (MHz)	Reading (dBuV)	Correct (dB/m)	Result (dBuV/m)	Limit (dBuV/m)	Margin (dB)	Remark
1	7319.000	37.37	7.66	45.03	74.00	-28.97	peak
2	9585.000	37.58	13.38	50.96	74.00	-23.04	peak
3	11081.000	34.19	15.51	49.70	74.00	-24.30	peak
4	12720.000	28.90	19.65	48.55	74.00	-25.45	peak
5	13545.000	27.25	22.12	49.37	74.00	-24.63	peak
6	18000.000	20.02	29.61	49.63	74.00	-24.37	peak



Test Mode:	802.11a 20	Frequency(MHz):	5240
Polarity:	Vertical	Test Voltage:	AC 120V_60Hz

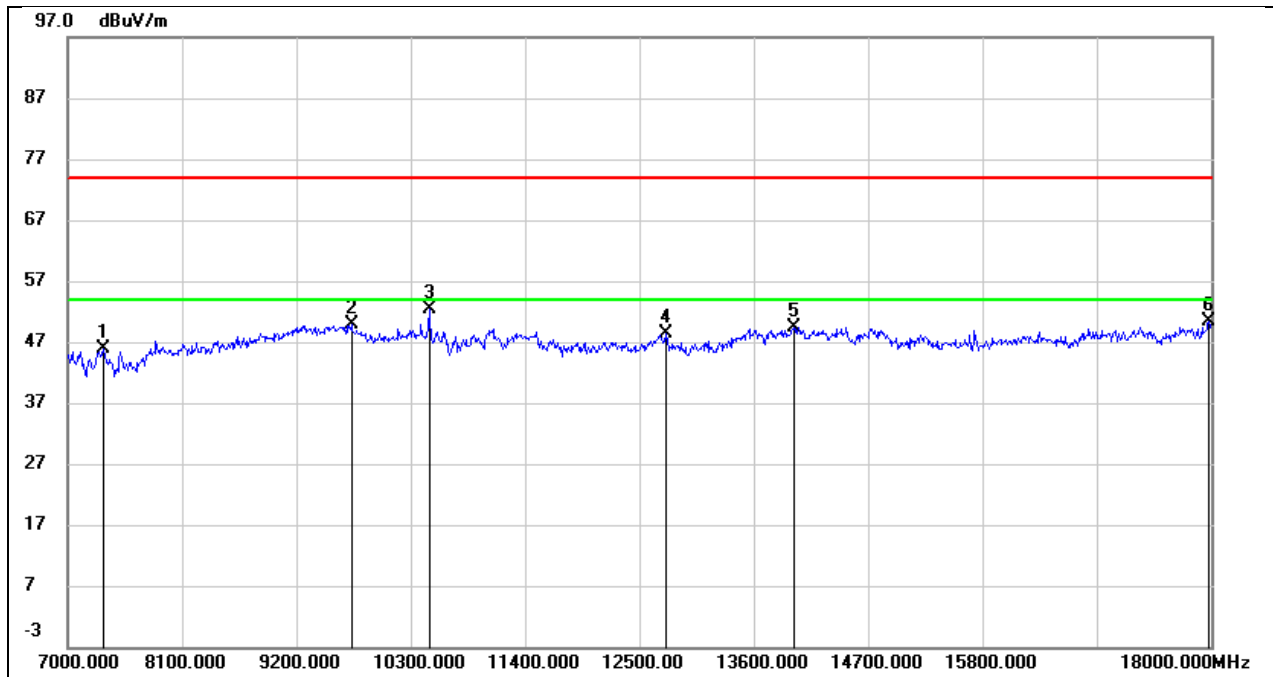

No.	Frequency (MHz)	Reading (dBuV)	Correct (dB/m)	Result (dBuV/m)	Limit (dBuV/m)	Margin (dB)	Remark
1	7341.000	37.66	8.30	45.96	74.00	-28.04	peak
2	9728.000	36.50	13.36	49.86	74.00	-24.14	peak
3	10476.000	39.17	13.26	52.43	74.00	-21.57	peak
4	12753.000	29.53	18.73	48.26	74.00	-25.74	peak
5	13985.000	27.48	21.95	49.43	74.00	-24.57	peak
6	17978.000	22.99	27.28	50.27	74.00	-23.73	peak

Test Mode:	802.11a 20	Frequency(MHz):	5260
Polarity:	Horizontal	Test Voltage:	AC 120V_60Hz

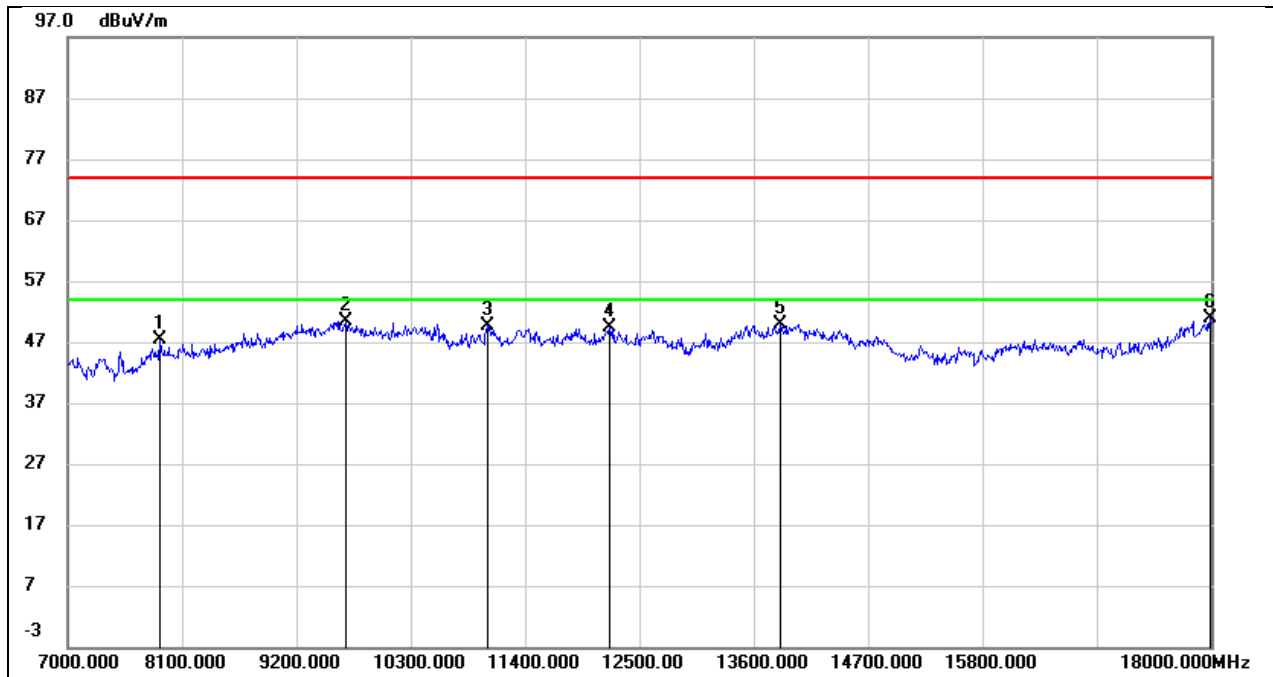

No.	Frequency (MHz)	Reading (dBuV)	Correct (dB/m)	Result (dBuV/m)	Limit (dBuV/m)	Margin (dB)	Remark
1	7891.000	39.30	8.04	47.34	74.00	-26.66	peak
2	9673.000	36.91	13.58	50.49	74.00	-23.51	peak
3	11037.000	34.27	15.27	49.54	74.00	-24.46	peak
4	12214.000	30.60	18.73	49.33	74.00	-24.67	peak
5	13853.000	26.91	23.01	49.92	74.00	-24.08	peak
6	17989.000	21.37	29.49	50.86	74.00	-23.14	peak

Test Mode:	802.11a 20	Frequency(MHz):	5260
Polarity:	Vertical	Test Voltage:	AC 120V_60Hz

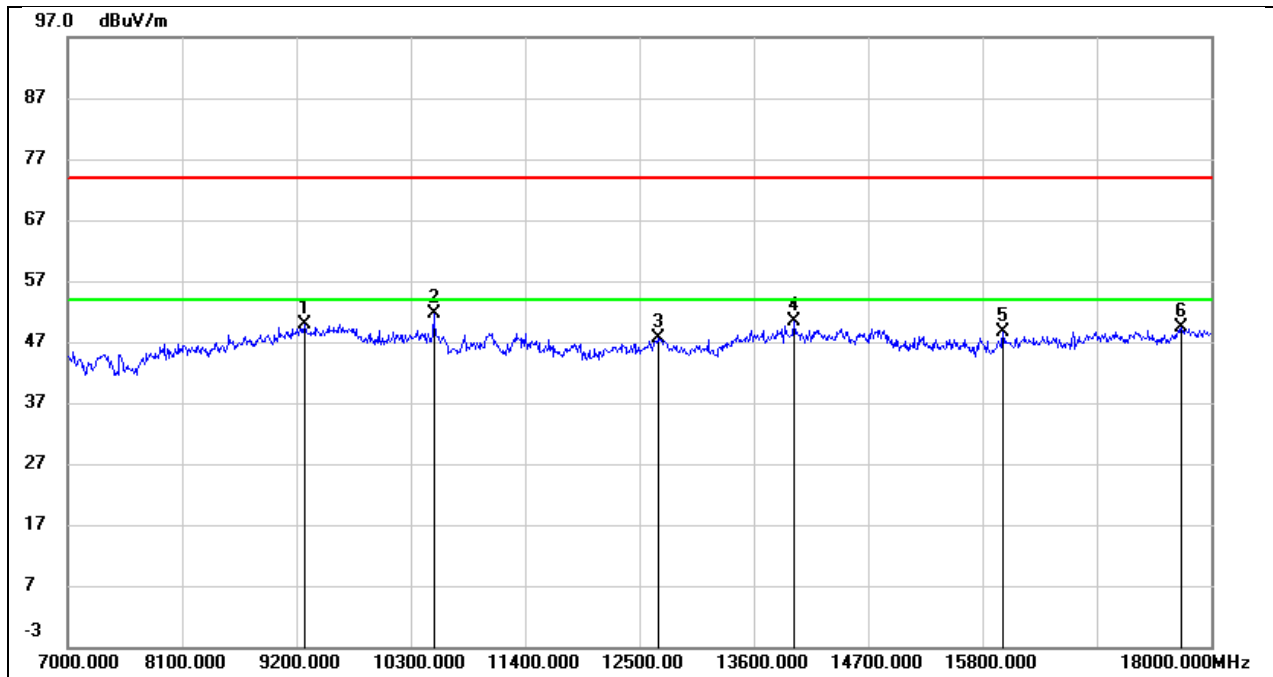

No.	Frequency (MHz)	Reading (dBuV)	Correct (dB/m)	Result (dBuV/m)	Limit (dBuV/m)	Margin (dB)	Remark
1	9277.000	37.91	11.99	49.90	74.00	-24.10	peak
2	10520.000	38.28	13.36	51.64	74.00	-22.36	peak
3	12676.000	29.13	18.47	47.60	74.00	-26.40	peak
4	13985.000	28.34	21.95	50.29	74.00	-23.71	peak
5	15998.000	25.87	22.86	48.73	74.00	-25.27	peak
6	17714.000	23.64	25.71	49.35	74.00	-24.65	peak

Test Mode:	802.11a 20	Frequency(MHz):	5280
Polarity:	Horizontal	Test Voltage:	AC 120V_60Hz

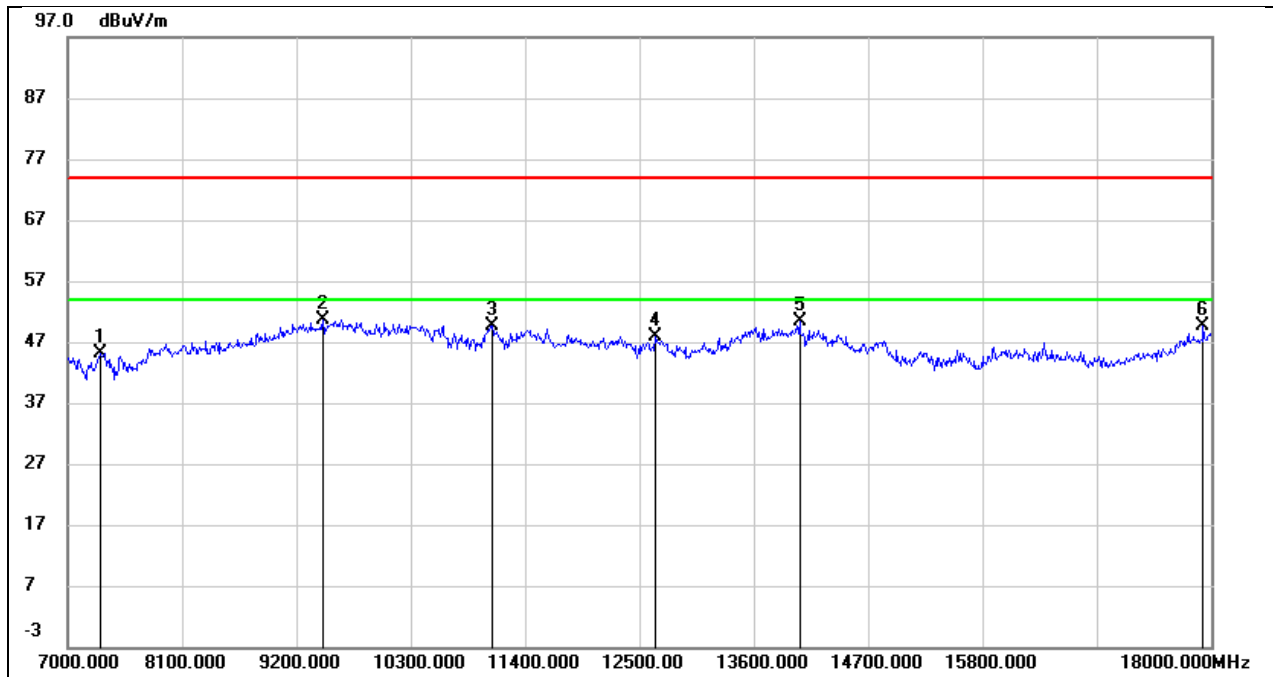

No.	Frequency (MHz)	Reading (dBuV)	Correct (dB/m)	Result (dBuV/m)	Limit (dBuV/m)	Margin (dB)	Remark
1	7319.000	37.48	7.66	45.14	74.00	-28.86	peak
2	9453.000	38.12	12.55	50.67	74.00	-23.33	peak
3	11081.000	34.20	15.51	49.71	74.00	-24.29	peak
4	12654.000	28.45	19.39	47.84	74.00	-26.16	peak
5	14040.000	26.87	23.44	50.31	74.00	-23.69	peak
6	17923.000	20.83	28.78	49.61	74.00	-24.39	peak

Test Mode:	802.11a 20	Frequency(MHz):	5280
Polarity:	Vertical	Test Voltage:	AC 120V_60Hz

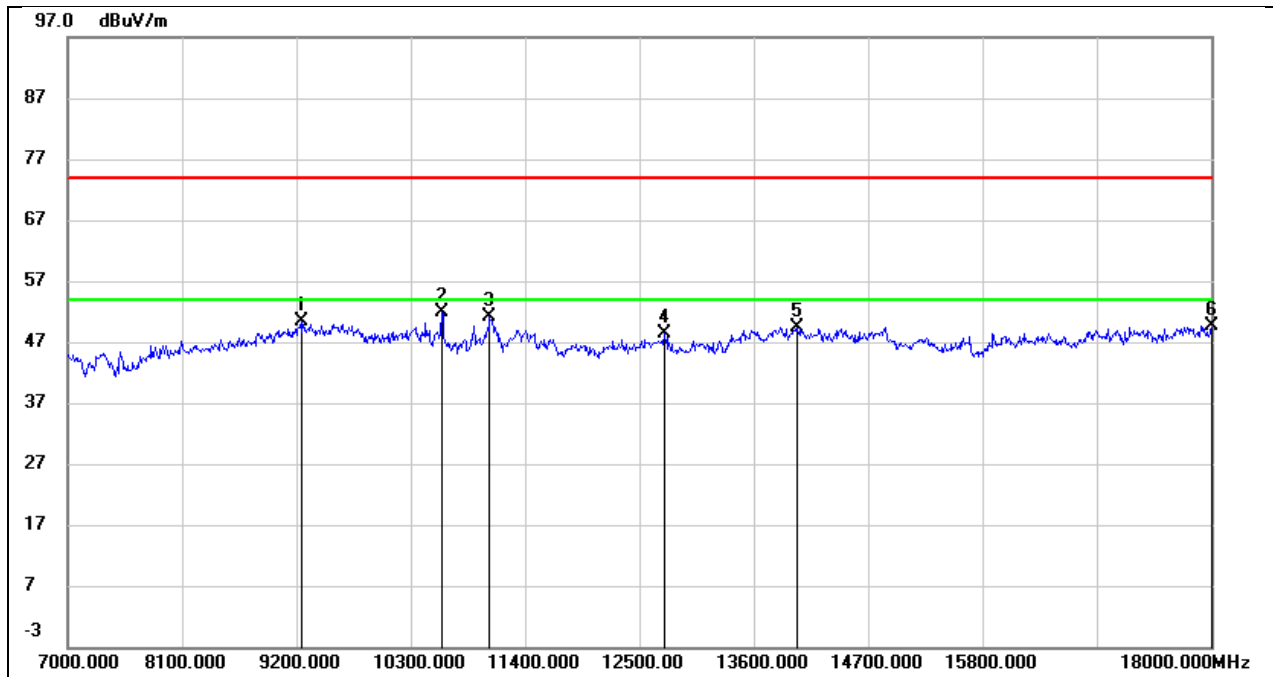

No.	Frequency (MHz)	Reading (dBuV)	Correct (dB/m)	Result (dBuV/m)	Limit (dBuV/m)	Margin (dB)	Remark
1	9244.000	38.37	11.92	50.29	74.00	-23.71	peak
2	10597.000	38.32	13.51	51.83	74.00	-22.17	peak
3	11059.000	36.62	14.51	51.13	74.00	-22.87	peak
4	12742.000	29.59	18.70	48.29	74.00	-25.71	peak
5	14018.000	27.30	21.99	49.29	74.00	-24.71	peak
6	18000.000	22.27	27.41	49.68	74.00	-24.32	peak

Test Mode:	802.11a 20	Frequency(MHz):	5320
Polarity:	Horizontal	Test Voltage:	AC 120V_60Hz

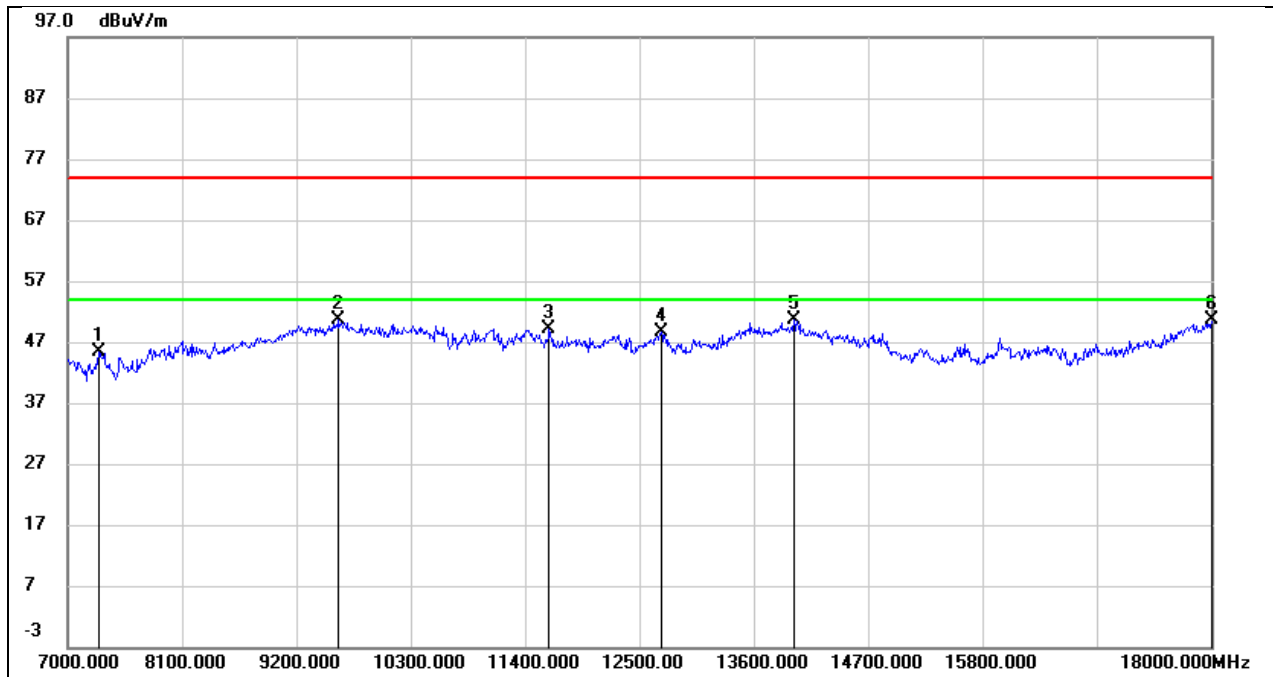

No.	Frequency (MHz)	Reading (dBuV)	Correct (dB/m)	Result (dBuV/m)	Limit (dBuV/m)	Margin (dB)	Remark
1	7297.000	37.79	7.64	45.43	74.00	-28.57	peak
2	9607.000	37.05	13.48	50.53	74.00	-23.47	peak
3	11631.000	31.14	18.08	49.22	74.00	-24.78	peak
4	12709.000	28.98	19.60	48.58	74.00	-25.42	peak
5	13985.000	26.97	23.55	50.52	74.00	-23.48	peak
6	18000.000	21.04	29.61	50.65	74.00	-23.35	peak

Test Mode:	802.11a 20	Frequency(MHz):	5320
Polarity:	Vertical	Test Voltage:	AC 120V_60Hz

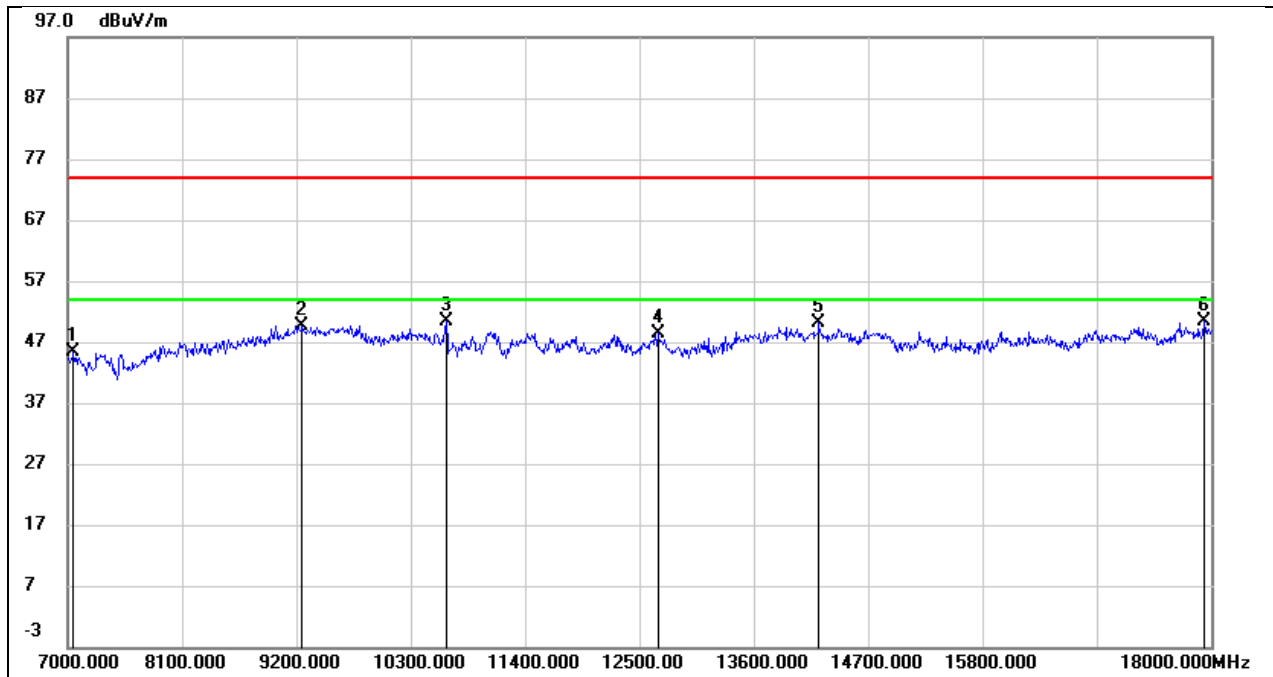

No.	Frequency (MHz)	Reading (dBuV)	Correct (dB/m)	Result (dBuV/m)	Limit (dBuV/m)	Margin (dB)	Remark
1	7055.000	37.19	8.09	45.28	74.00	-28.72	peak
2	9255.000	37.67	11.93	49.60	74.00	-24.40	peak
3	10641.000	36.88	13.58	50.46	74.00	-23.54	peak
4	12676.000	30.02	18.47	48.49	74.00	-25.51	peak
5	14227.000	28.50	21.61	50.11	74.00	-23.89	peak
6	17934.000	23.26	27.00	50.26	74.00	-23.74	peak

Test Mode:	802.11a 20	Frequency(MHz):	5500
Polarity:	Horizontal	Test Voltage:	AC 120V_60Hz

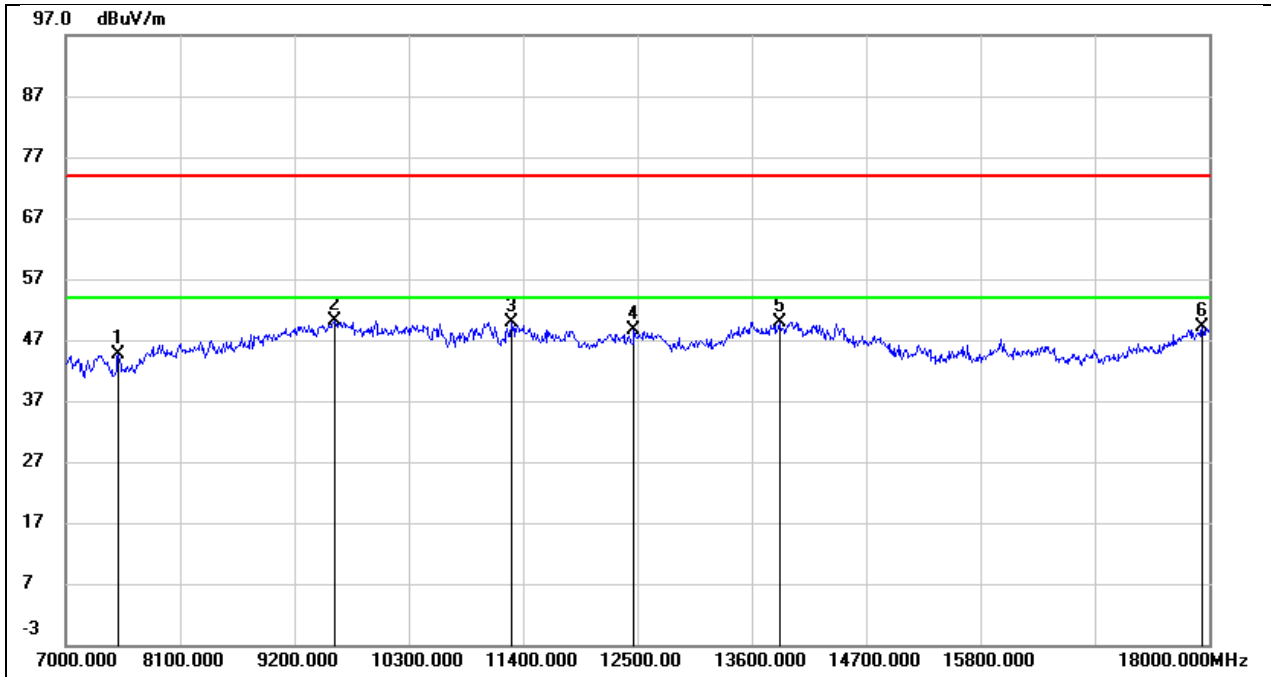

No.	Frequency (MHz)	Reading (dBuV)	Correct (dB/m)	Result (dBuV/m)	Limit (dBuV/m)	Margin (dB)	Remark
1	7506.000	36.89	7.84	44.73	74.00	-29.27	peak
2	9585.000	36.82	13.38	50.20	74.00	-23.80	peak
3	11290.000	33.16	16.70	49.86	74.00	-24.14	peak
4	12467.000	29.57	18.99	48.56	74.00	-25.44	peak
5	13864.000	26.83	23.06	49.89	74.00	-24.11	peak
6	17934.000	20.31	28.91	49.22	74.00	-24.78	peak



Test Mode:	802.11a 20	Frequency(MHz):	5500
Polarity:	Vertical	Test Voltage:	AC 120V_60Hz

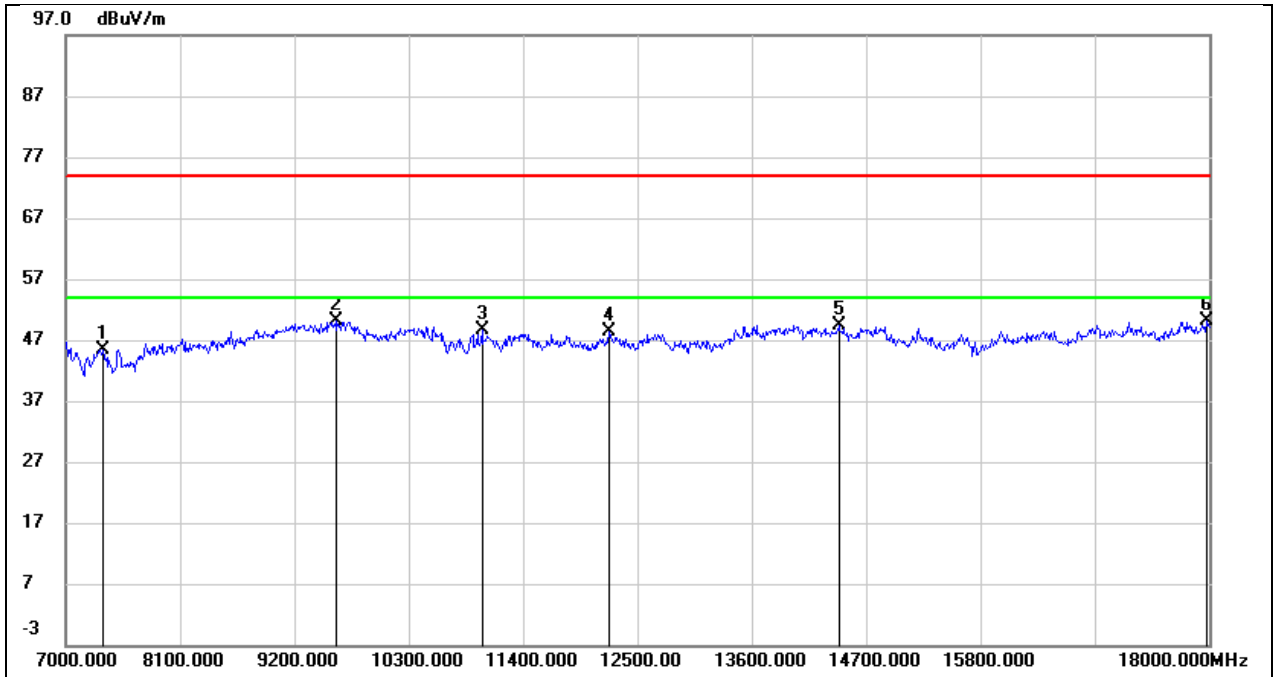

No.	Frequency (MHz)	Reading (dBuV)	Correct (dB/m)	Result (dBuV/m)	Limit (dBuV/m)	Margin (dB)	Remark
1	7363.000	37.08	8.31	45.39	74.00	-28.61	peak
2	9596.000	36.82	13.30	50.12	74.00	-23.88	peak
3	11004.000	34.40	14.27	48.67	74.00	-25.33	peak
4	12225.000	30.69	17.74	48.43	74.00	-25.57	peak
5	14436.000	28.49	20.98	49.47	74.00	-24.53	peak
6	17978.000	22.74	27.28	50.02	74.00	-23.98	peak

Test Mode:	802.11a 20	Frequency(MHz):	5580
Polarity:	Horizontal	Test Voltage:	AC 120V_60Hz

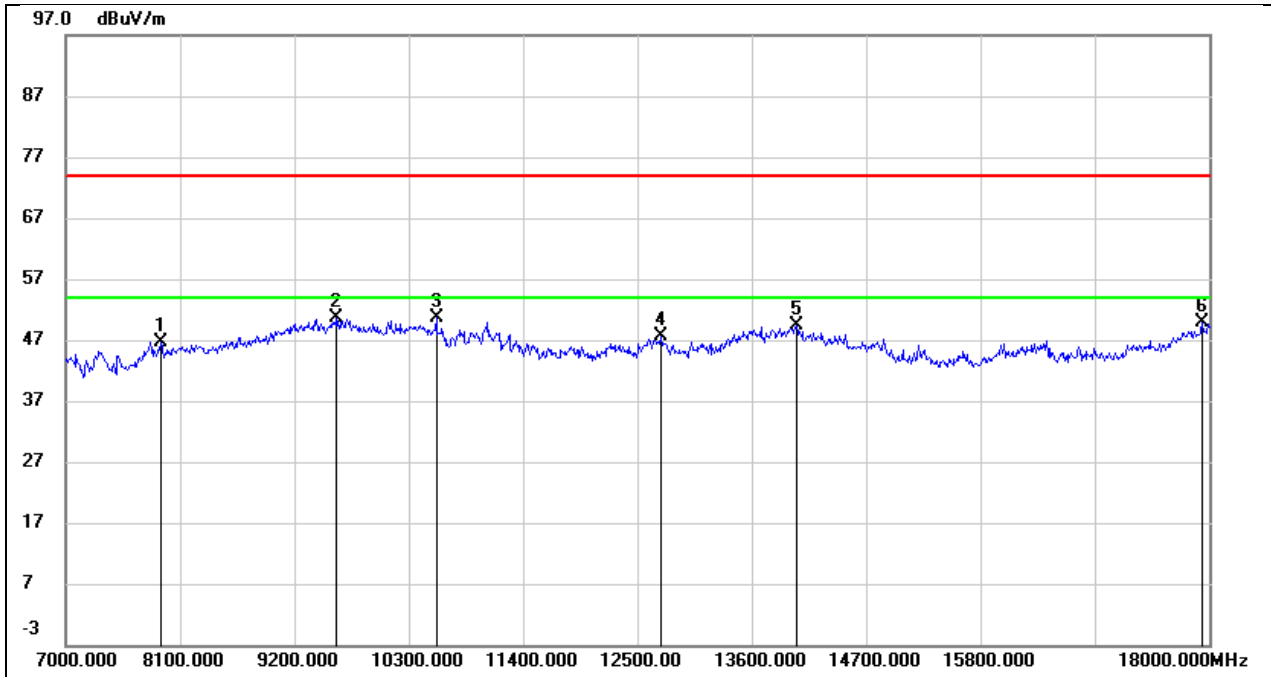

No.	Frequency (MHz)	Reading (dBuV)	Correct (dB/m)	Result (dBuV/m)	Limit (dBuV/m)	Margin (dB)	Remark
1	7913.000	38.57	8.05	46.62	74.00	-27.38	peak
2	9607.000	37.24	13.48	50.72	74.00	-23.28	peak
3	10564.000	37.03	13.72	50.75	74.00	-23.25	peak
4	12720.000	28.00	19.65	47.65	74.00	-26.35	peak
5	14029.000	25.81	23.49	49.30	74.00	-24.70	peak
6	17934.000	20.91	28.91	49.82	74.00	-24.18	peak

Test Mode:	802.11a 20	Frequency(MHz):	5580
Polarity:	Vertical	Test Voltage:	AC 120V_60Hz

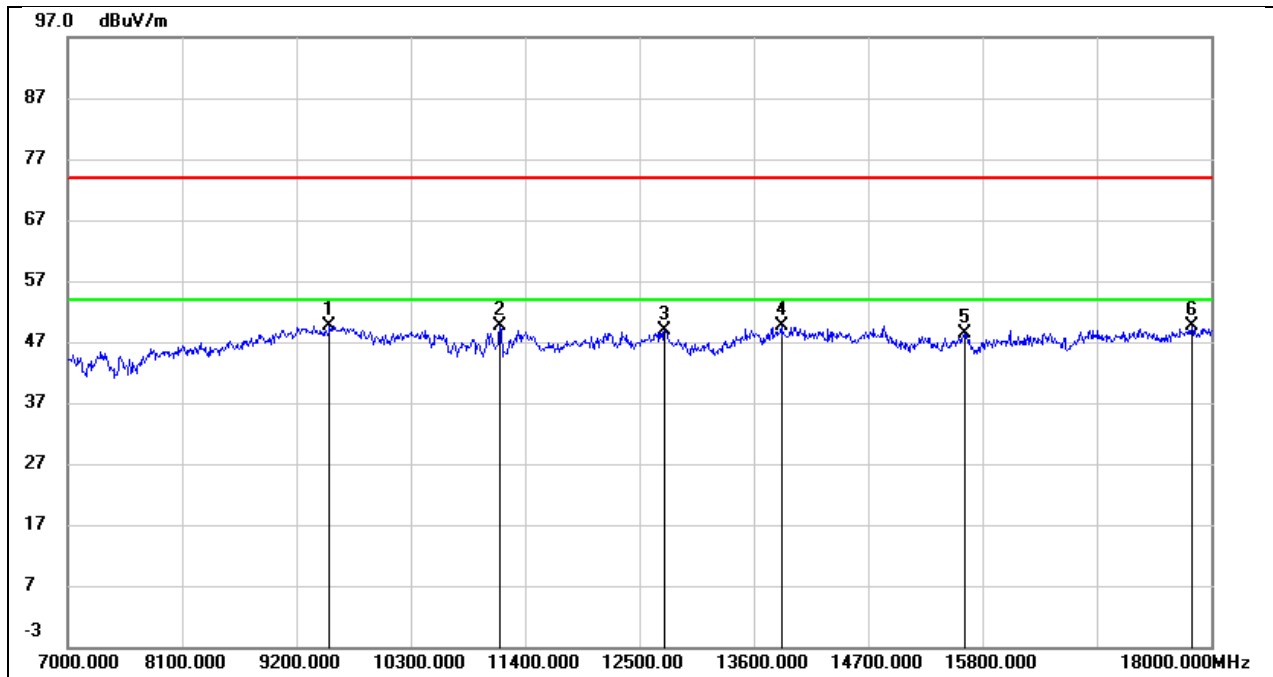

No.	Frequency (MHz)	Reading (dBuV)	Correct (dB/m)	Result (dBuV/m)	Limit (dBuV/m)	Margin (dB)	Remark
1	9519.000	36.72	12.94	49.66	74.00	-24.34	peak
2	11158.000	34.70	14.91	49.61	74.00	-24.39	peak
3	12742.000	30.27	18.70	48.97	74.00	-25.03	peak
4	13864.000	28.19	21.43	49.62	74.00	-24.38	peak
5	15624.000	27.42	20.96	48.38	74.00	-25.62	peak
6	17813.000	23.27	26.24	49.51	74.00	-24.49	peak

Test Mode:	802.11a 20	Frequency(MHz):	5700
Polarity:	Horizontal	Test Voltage:	AC 120V_60Hz

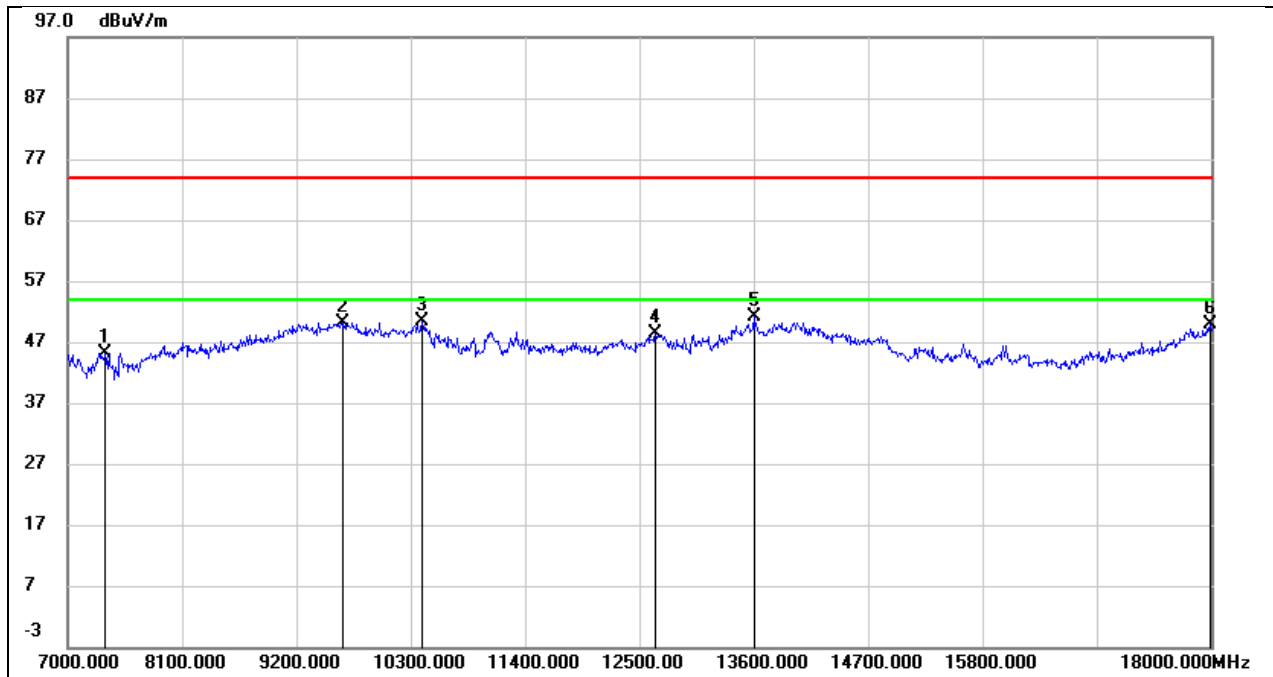

No.	Frequency (MHz)	Reading (dBuV)	Correct (dB/m)	Result (dBuV/m)	Limit (dBuV/m)	Margin (dB)	Remark
1	7363.000	37.53	7.70	45.23	74.00	-28.77	peak
2	9651.000	36.64	13.55	50.19	74.00	-23.81	peak
3	10410.000	36.90	13.38	50.28	74.00	-23.72	peak
4	12654.000	28.87	19.39	48.26	74.00	-25.74	peak
5	13600.000	28.86	22.22	51.08	74.00	-22.92	peak
6	17989.000	20.45	29.49	49.94	74.00	-24.06	peak

Test Mode:	802.11a 20	Frequency(MHz):	5700
Polarity:	Vertical	Test Voltage:	AC 120V_60Hz

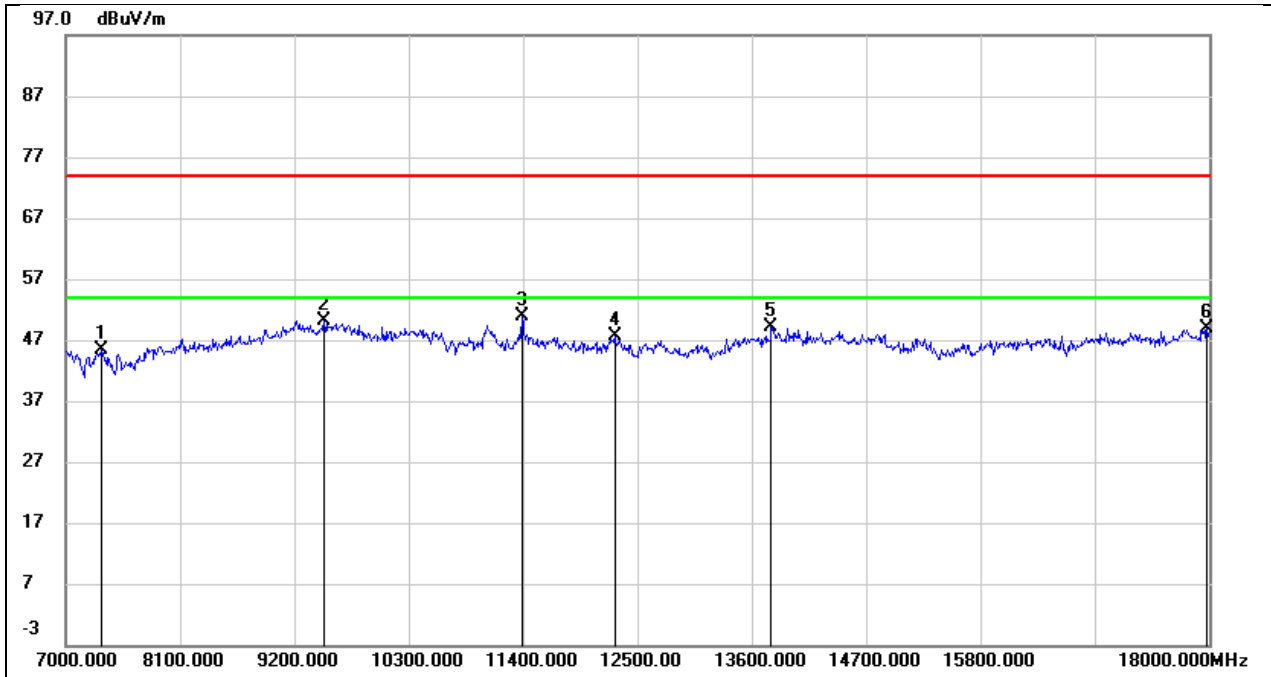

No.	Frequency (MHz)	Reading (dBuV)	Correct (dB/m)	Result (dBuV/m)	Limit (dBuV/m)	Margin (dB)	Remark
1	7341.000	37.08	8.30	45.38	74.00	-28.62	peak
2	9486.000	37.34	12.78	50.12	74.00	-23.88	peak
3	11389.000	34.90	15.95	50.85	74.00	-23.15	peak
4	12280.000	29.69	17.84	47.53	74.00	-26.47	peak
5	13787.000	28.07	21.12	49.19	74.00	-24.81	peak
6	17978.000	21.51	27.28	48.79	74.00	-25.21	peak

Test Mode:	802.11a 20	Frequency(MHz):	5720
Polarity:	Horizontal	Test Voltage:	AC 120V_60Hz

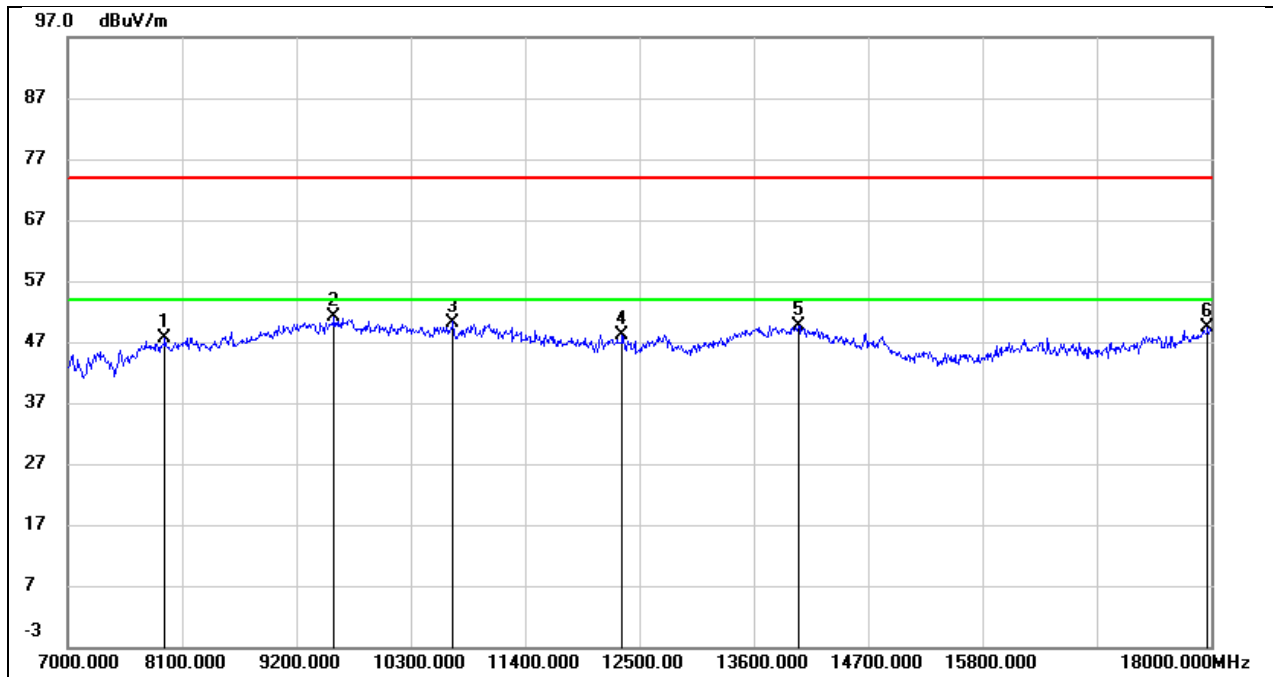

No.	Frequency (MHz)	Reading (dBuV)	Correct (dB/m)	Result (dBuV/m)	Limit (dBuV/m)	Margin (dB)	Remark
1	7935.000	39.63	8.05	47.68	74.00	-26.32	peak
2	9563.000	37.86	13.23	51.09	74.00	-22.91	peak
3	10707.000	36.11	14.14	50.25	74.00	-23.75	peak
4	12335.000	29.28	18.89	48.17	74.00	-25.83	peak
5	14029.000	26.18	23.49	49.67	74.00	-24.33	peak
6	17967.000	20.20	29.26	49.46	74.00	-24.54	peak

Test Mode:	802.11a 20	Frequency(MHz):	5720
Polarity:	Vertical	Test Voltage:	AC 120V_60Hz

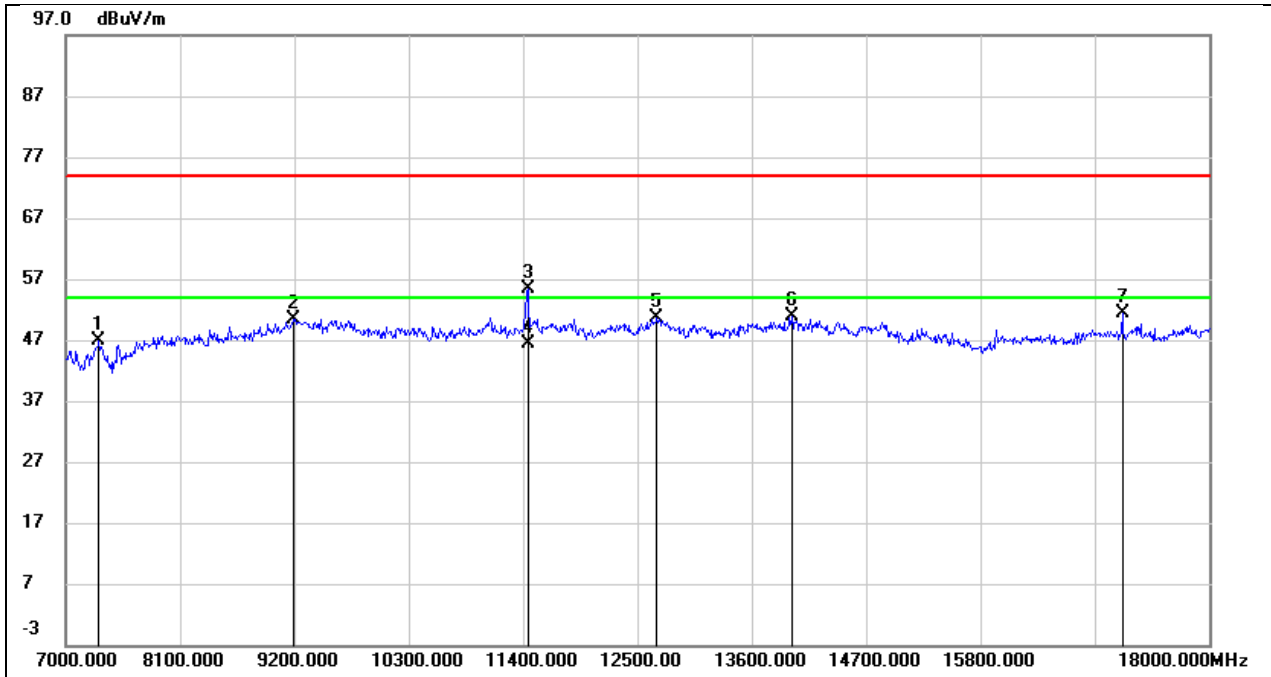

No.	Frequency (MHz)	Reading (dBuV)	Correct (dB/m)	Result (dBuV/m)	Limit (dBuV/m)	Margin (dB)	Remark
1	7319.000	38.53	8.30	46.83	74.00	-27.17	peak
2	9189.000	38.63	11.76	50.39	74.00	-23.61	peak
3	11444.000	39.17	16.15	55.32	74.00	-18.68	peak
4	11444.000	30.18	16.15	46.33	54.00	-7.67	AVG
5	12687.000	32.10	18.51	50.61	74.00	-23.39	peak
6	13985.000	28.91	21.95	50.86	74.00	-23.14	peak
7	17164.000	26.61	24.82	51.43	74.00	-22.57	peak

Test Mode:	802.11a 20	Frequency(MHz):	5745
Polarity:	Horizontal	Test Voltage:	AC 120V_60Hz

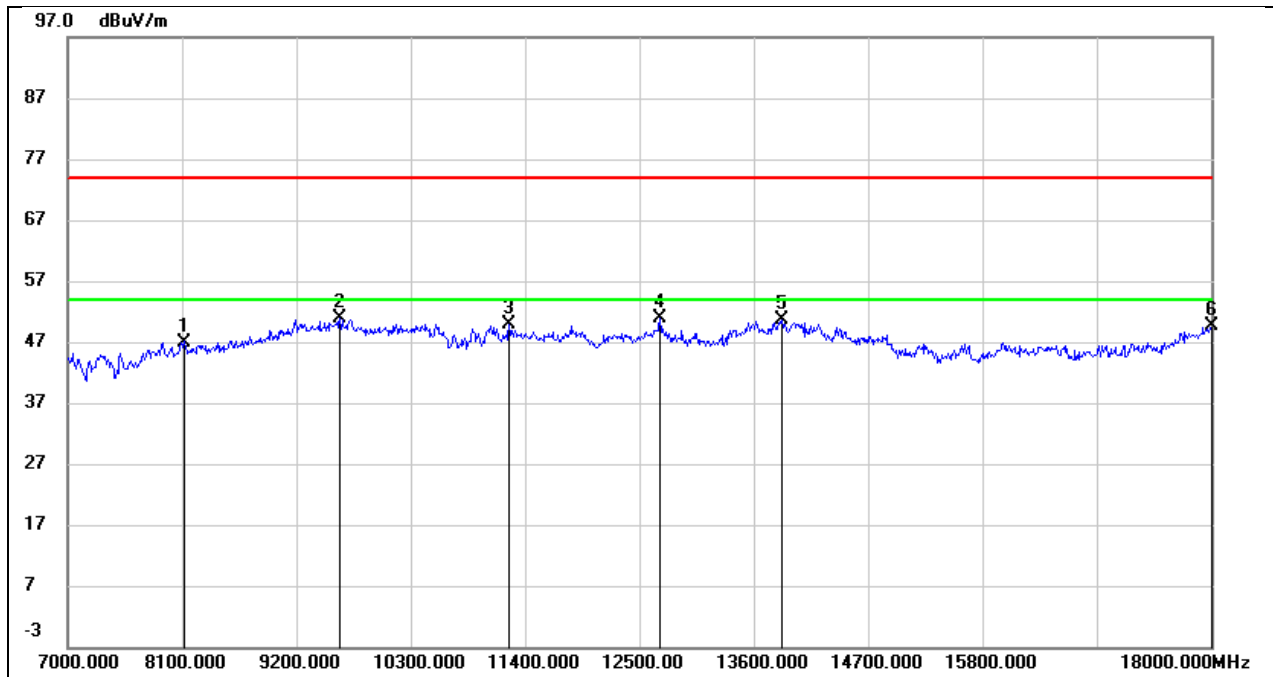

No.	Frequency (MHz)	Reading (dBuV)	Correct (dB/m)	Result (dBuV/m)	Limit (dBuV/m)	Margin (dB)	Remark
1	8122.000	38.76	8.24	47.00	74.00	-27.00	peak
2	9618.000	37.48	13.49	50.97	74.00	-23.03	peak
3	11246.000	33.41	16.44	49.85	74.00	-24.15	peak
4	12698.000	31.20	19.56	50.76	74.00	-23.24	peak
5	13864.000	27.54	23.06	50.60	74.00	-23.40	peak
6	18000.000	20.07	29.61	49.68	74.00	-24.32	peak



Test Mode:	802.11a 20	Frequency(MHz):	5745
Polarity:	Vertical	Test Voltage:	AC 120V_60Hz

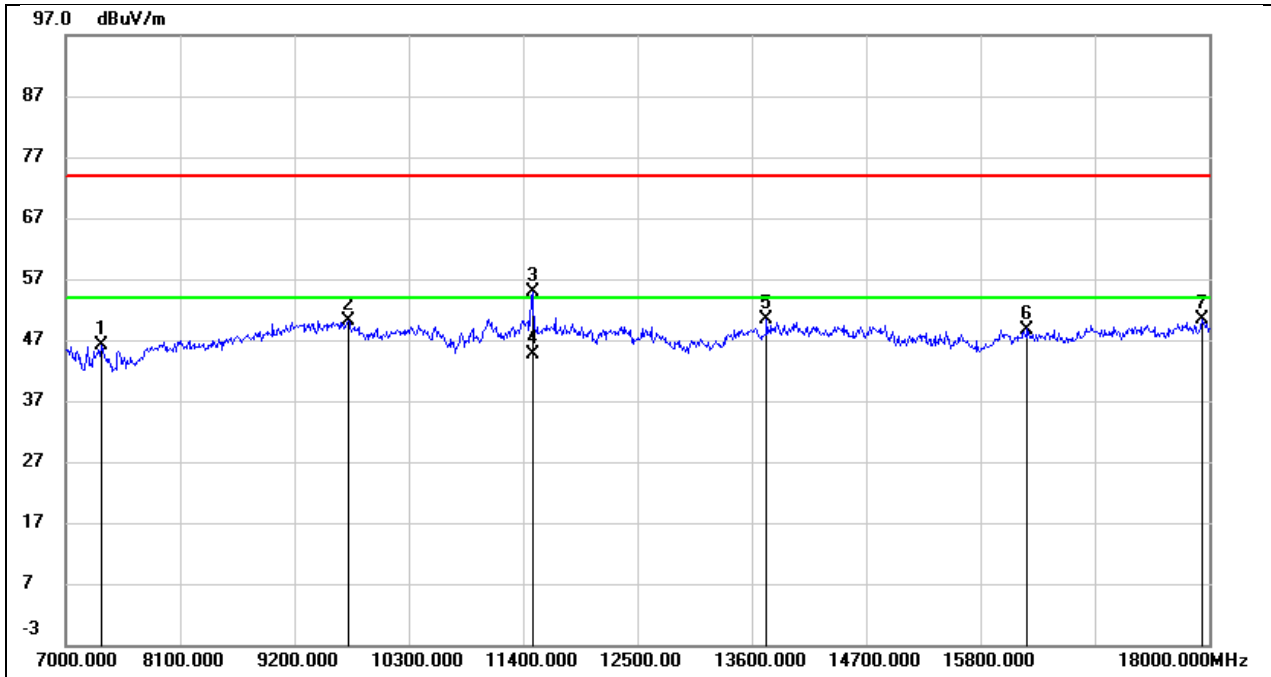

No.	Frequency (MHz)	Reading (dBuV)	Correct (dB/m)	Result (dBuV/m)	Limit (dBuV/m)	Margin (dB)	Remark
1	7341.000	37.80	8.30	46.10	74.00	-27.90	peak
2	9717.000	36.90	13.35	50.25	74.00	-23.75	peak
3	11488.000	38.57	16.29	54.86	74.00	-19.14	peak
4	11488.000	28.39	16.29	44.68	54.00	-9.32	AVG
5	13743.000	29.43	20.99	50.42	74.00	-23.58	peak
6	16251.000	24.74	24.01	48.75	74.00	-25.25	peak
7	17934.000	23.38	27.00	50.38	74.00	-23.62	peak

Test Mode:	802.11a 20	Frequency(MHz):	5785
Polarity:	Horizontal	Test Voltage:	AC 120V_60Hz

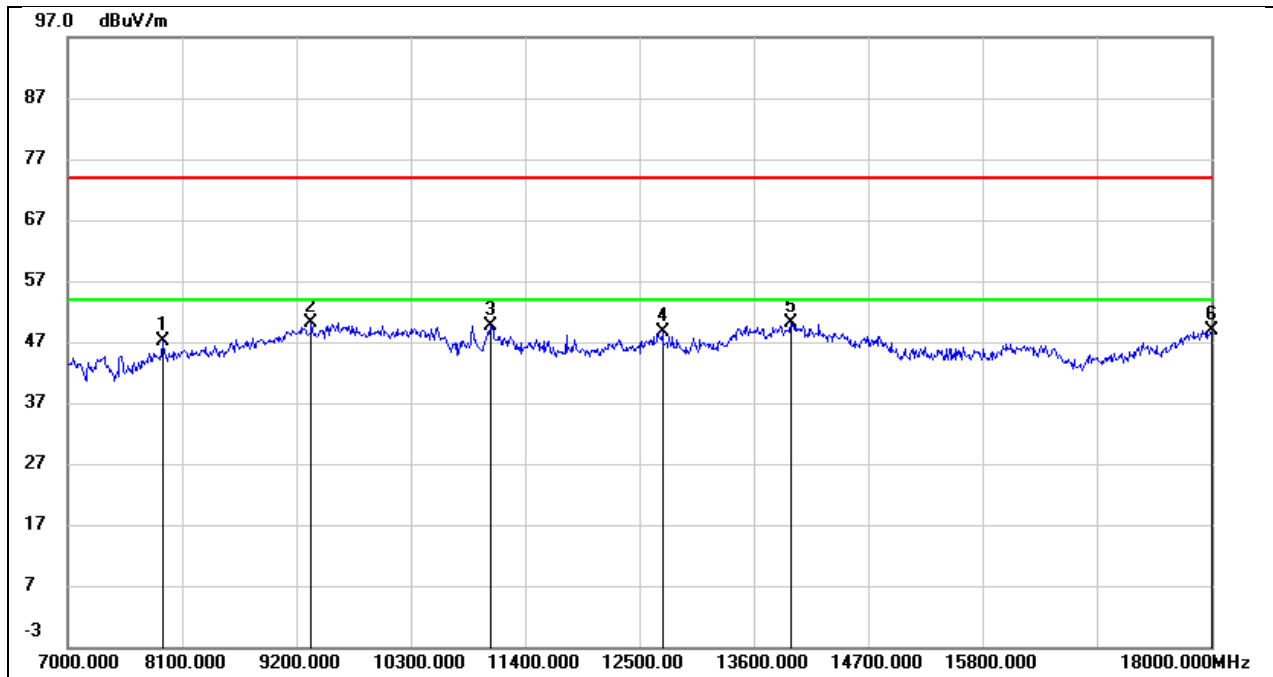

No.	Frequency (MHz)	Reading (dBuV)	Correct (dB/m)	Result (dBuV/m)	Limit (dBuV/m)	Margin (dB)	Remark
1	7913.000	39.04	8.05	47.09	74.00	-26.91	peak
2	9343.000	38.18	12.03	50.21	74.00	-23.79	peak
3	11070.000	34.29	15.44	49.73	74.00	-24.27	peak
4	12720.000	28.88	19.65	48.53	74.00	-25.47	peak
5	13952.000	26.76	23.42	50.18	74.00	-23.82	peak
6	18000.000	19.23	29.61	48.84	74.00	-25.16	peak

Test Mode:	802.11a 20	Frequency(MHz):	5785
Polarity:	Vertical	Test Voltage:	AC 120V_60Hz

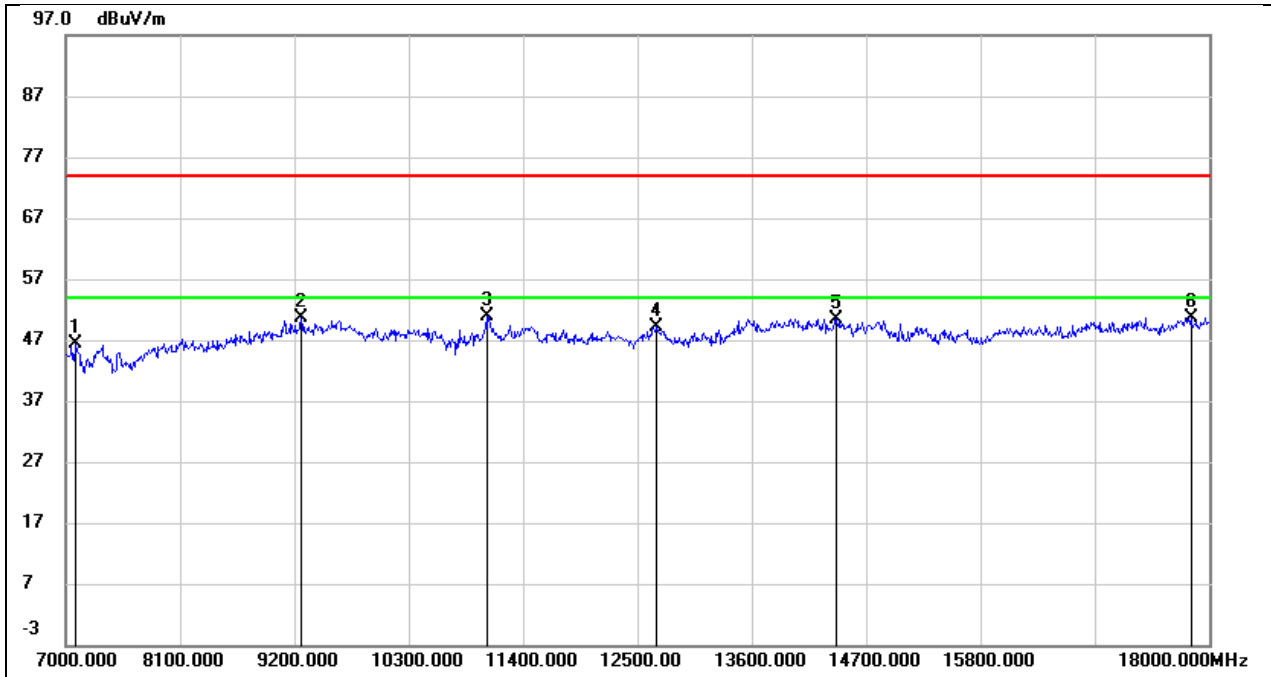

No.	Frequency (MHz)	Reading (dBuV)	Correct (dB/m)	Result (dBuV/m)	Limit (dBuV/m)	Margin (dB)	Remark
1	7099.000	38.31	8.14	46.45	74.00	-27.55	peak
2	9266.000	38.59	11.96	50.55	74.00	-23.45	peak
3	11048.000	36.45	14.46	50.91	74.00	-23.09	peak
4	12676.000	30.71	18.47	49.18	74.00	-24.82	peak
5	14414.000	29.50	20.99	50.49	74.00	-23.51	peak
6	17824.000	24.42	26.31	50.73	74.00	-23.27	peak

Test Mode:	802.11a 20	Frequency(MHz):	5825
Polarity:	Horizontal	Test Voltage:	AC 120V_60Hz

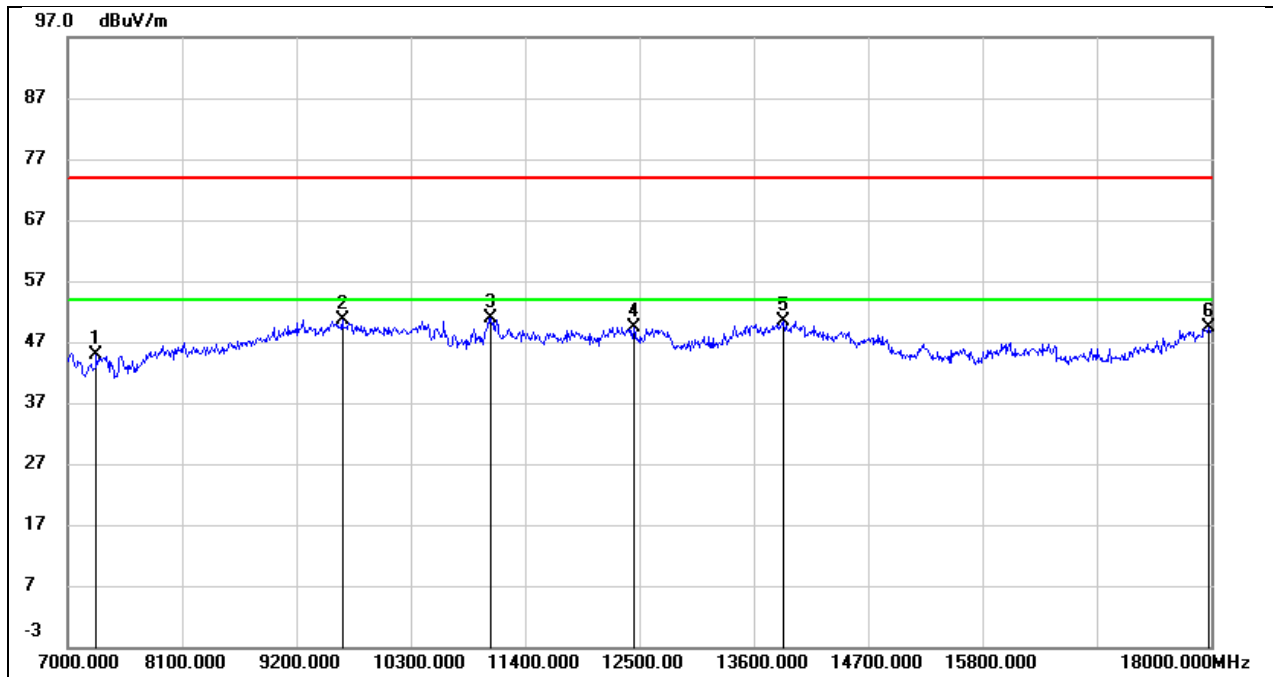

No.	Frequency (MHz)	Reading (dBuV)	Correct (dB/m)	Result (dBuV/m)	Limit (dBuV/m)	Margin (dB)	Remark
1	7275.000	37.26	7.60	44.86	74.00	-29.14	peak
2	9640.000	37.09	13.53	50.62	74.00	-23.38	peak
3	11070.000	35.40	15.44	50.84	74.00	-23.16	peak
4	12445.000	30.37	18.98	49.35	74.00	-24.65	peak
5	13886.000	27.26	23.15	50.41	74.00	-23.59	peak
6	17978.000	20.10	29.38	49.48	74.00	-24.52	peak

Test Mode:	802.11a 20	Frequency(MHz):	5825
Polarity:	Vertical	Test Voltage:	AC 120V_60Hz

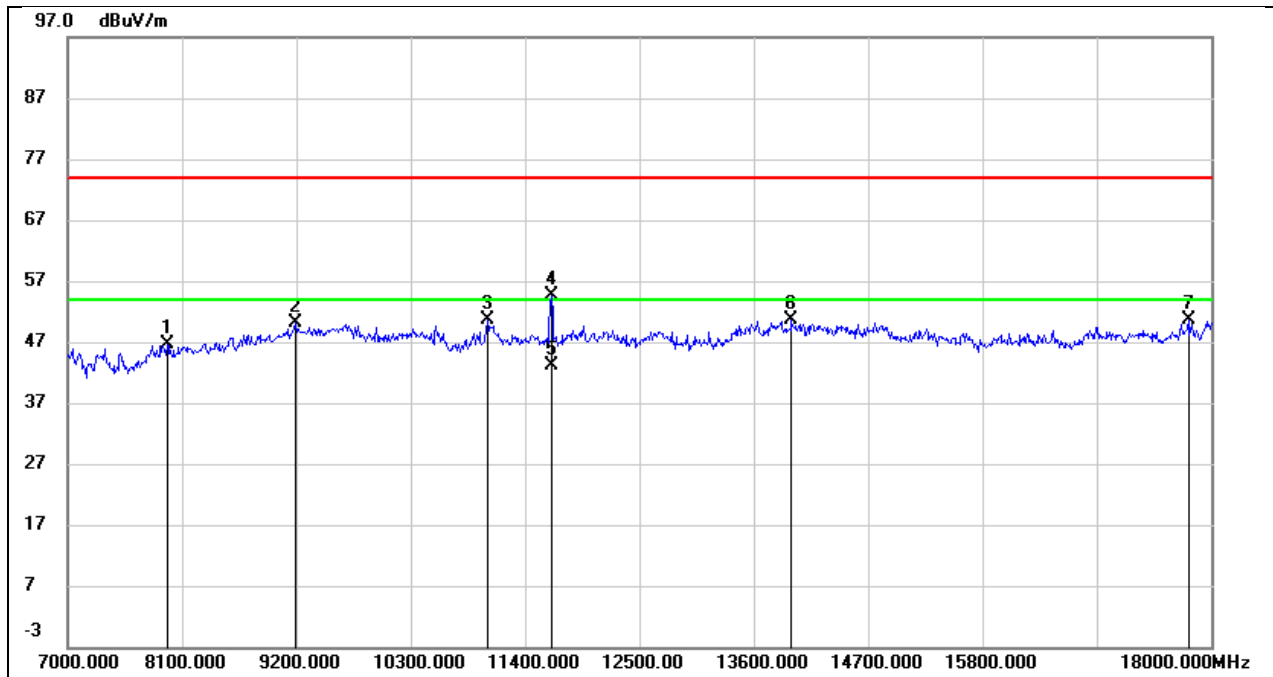

No.	Frequency (MHz)	Reading (dBuV)	Correct (dB/m)	Result (dBuV/m)	Limit (dBuV/m)	Margin (dB)	Remark
1	7957.000	38.01	8.55	46.56	74.00	-27.44	peak
2	9189.000	38.28	11.76	50.04	74.00	-23.96	peak
3	11037.000	36.16	14.42	50.58	74.00	-23.42	peak
4	11653.000	37.89	16.68	54.57	74.00	-19.43	peak
5	11653.000	26.57	16.68	43.25	54.00	-10.75	AVG
6	13963.000	28.68	21.85	50.53	74.00	-23.47	peak
7	17780.000	24.56	26.06	50.62	74.00	-23.38	peak

Test Mode:	802.11n HT20	Frequency(MHz):	5180
Polarity:	Horizontal	Test Voltage:	AC 120V_60Hz

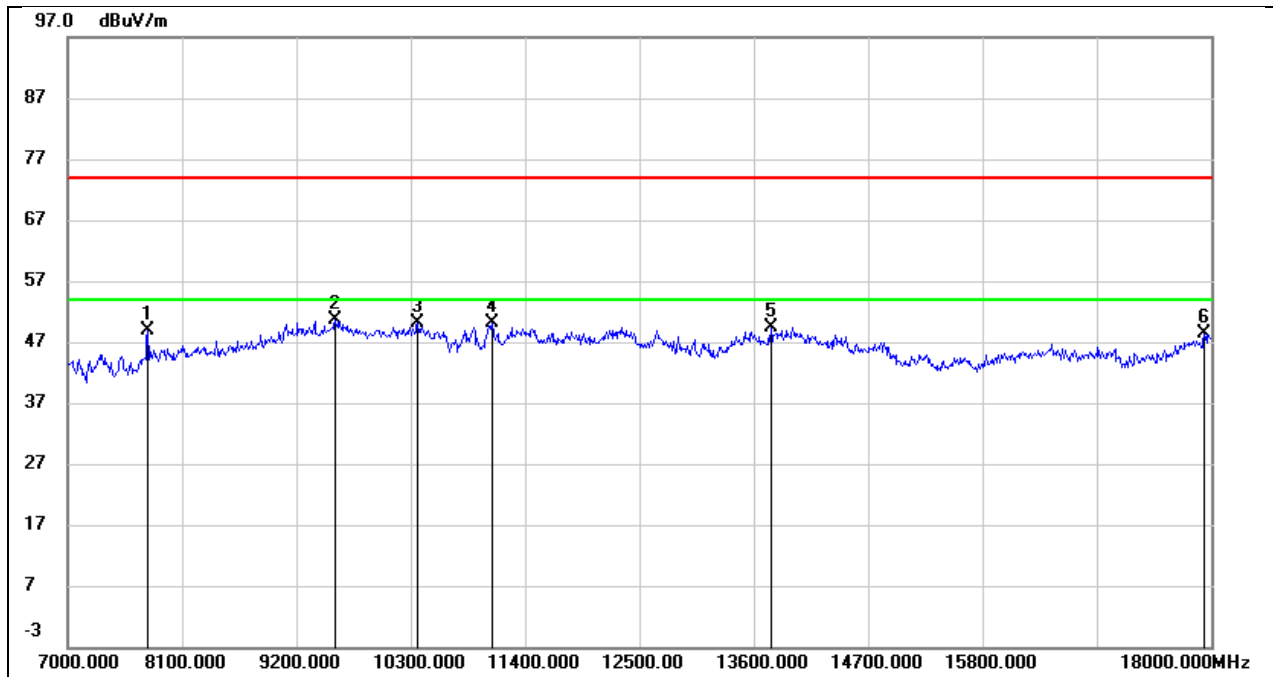

No.	Frequency (MHz)	Reading (dBuV)	Correct (dB/m)	Result (dBuV/m)	Limit (dBuV/m)	Margin (dB)	Remark
1	7770.000	40.87	7.99	48.86	74.00	-25.14	peak
2	9574.000	37.24	13.31	50.55	74.00	-23.45	peak
3	10366.000	36.90	13.32	50.22	74.00	-23.78	peak
4	11081.000	34.55	15.51	50.06	74.00	-23.94	peak
5	13765.000	26.74	22.70	49.44	74.00	-24.56	peak
6	17934.000	19.39	28.91	48.30	74.00	-25.70	peak

Test Mode:	802.11n HT20	Frequency(MHz):	5180
Polarity:	Vertical	Test Voltage:	AC 120V_60Hz

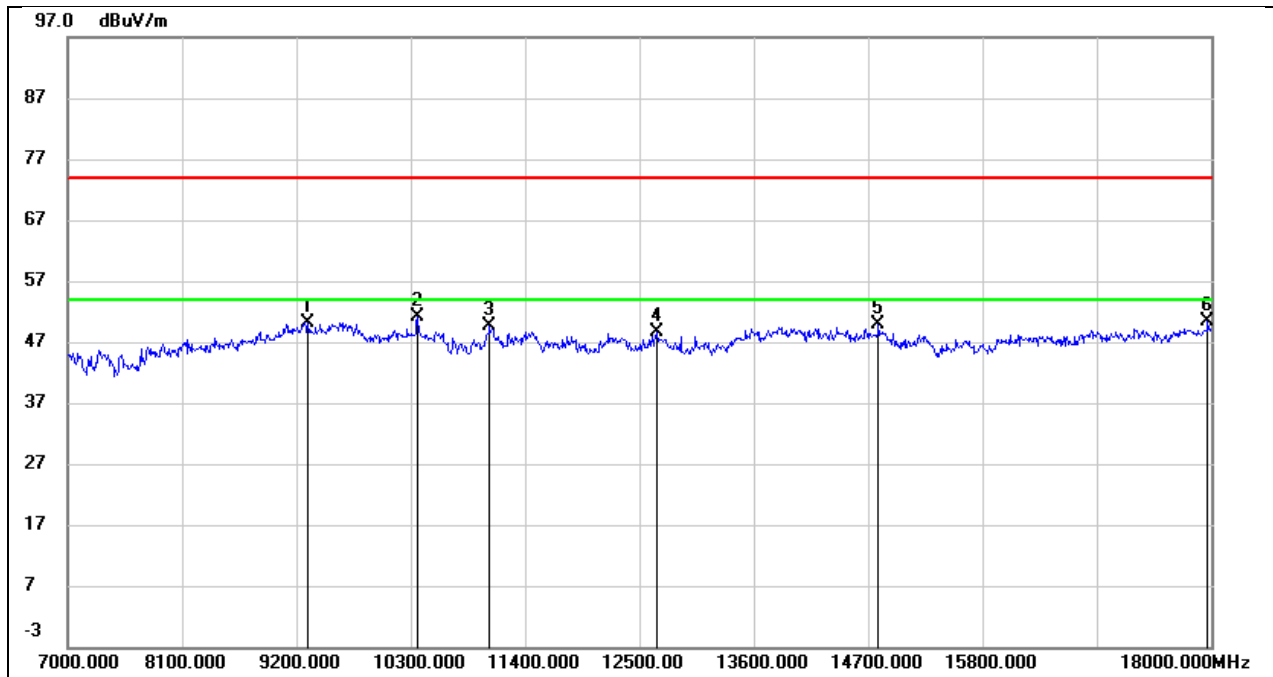

No.	Frequency (MHz)	Reading (dBuV)	Correct (dB/m)	Result (dBuV/m)	Limit (dBuV/m)	Margin (dB)	Remark
1	9310.000	38.11	12.07	50.18	74.00	-23.82	peak
2	10366.000	38.08	12.99	51.07	74.00	-22.93	peak
3	11059.000	35.12	14.51	49.63	74.00	-24.37	peak
4	12665.000	30.17	18.42	48.59	74.00	-25.41	peak
5	14799.000	29.17	20.60	49.77	74.00	-24.23	peak
6	17967.000	23.22	27.20	50.42	74.00	-23.58	peak

Test Mode:	802.11n HT20	Frequency(MHz):	5200
Polarity:	Horizontal	Test Voltage:	AC 120V_60Hz

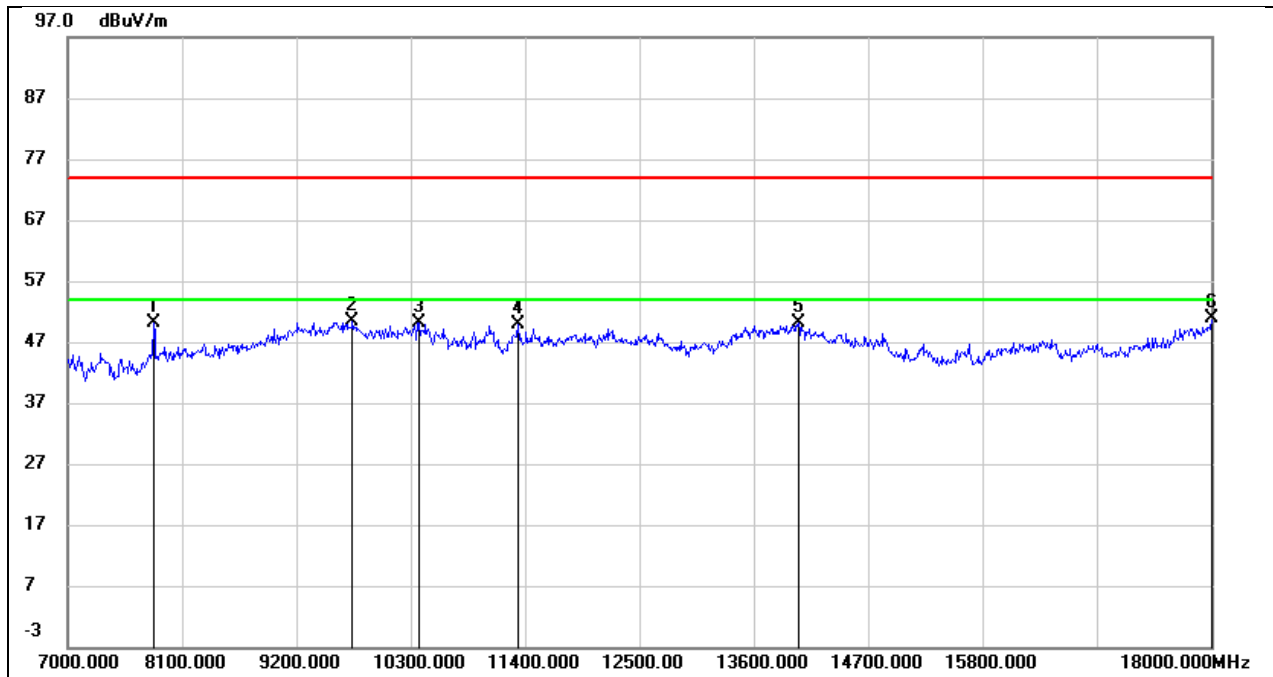

No.	Frequency (MHz)	Reading (dBuV)	Correct (dB/m)	Result (dBuV/m)	Limit (dBuV/m)	Margin (dB)	Remark
1	7825.000	41.99	8.02	50.01	74.00	-23.99	peak
2	9739.000	36.67	13.70	50.37	74.00	-23.63	peak
3	10377.000	36.82	13.34	50.16	74.00	-23.84	peak
4	11334.000	32.90	16.96	49.86	74.00	-24.14	peak
5	14029.000	26.64	23.49	50.13	74.00	-23.87	peak
6	18000.000	21.15	29.61	50.76	74.00	-23.24	peak



Test Mode:	802.11n HT20	Frequency(MHz):	5200
Polarity:	Vertical	Test Voltage:	AC 120V_60Hz

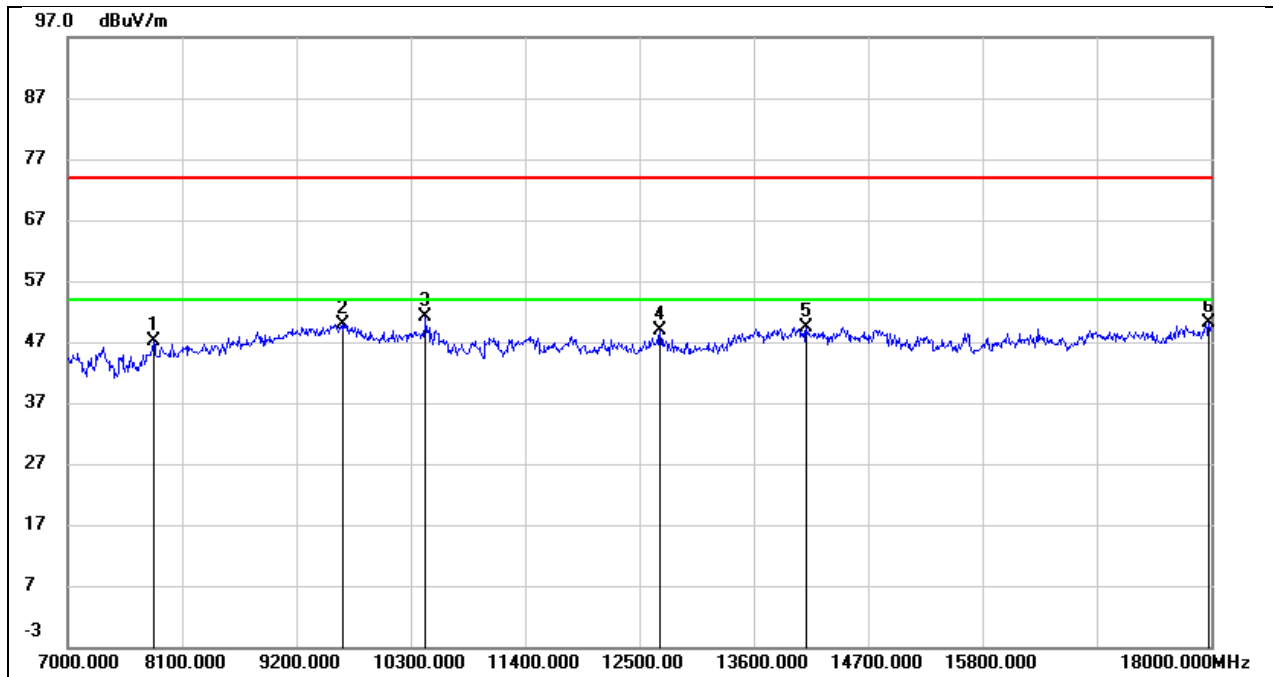

No.	Frequency (MHz)	Reading (dBuV)	Correct (dB/m)	Result (dBuV/m)	Limit (dBuV/m)	Margin (dB)	Remark
1	7825.000	38.62	8.52	47.14	74.00	-26.86	peak
2	9640.000	36.60	13.33	49.93	74.00	-24.07	peak
3	10443.000	38.06	13.17	51.23	74.00	-22.77	peak
4	12698.000	30.44	18.54	48.98	74.00	-25.02	peak
5	14106.000	27.55	21.86	49.41	74.00	-24.59	peak
6	17978.000	22.80	27.28	50.08	74.00	-23.92	peak

Test Mode:	802.11n HT20	Frequency(MHz):	5240
Polarity:	Horizontal	Test Voltage:	AC 120V_60Hz

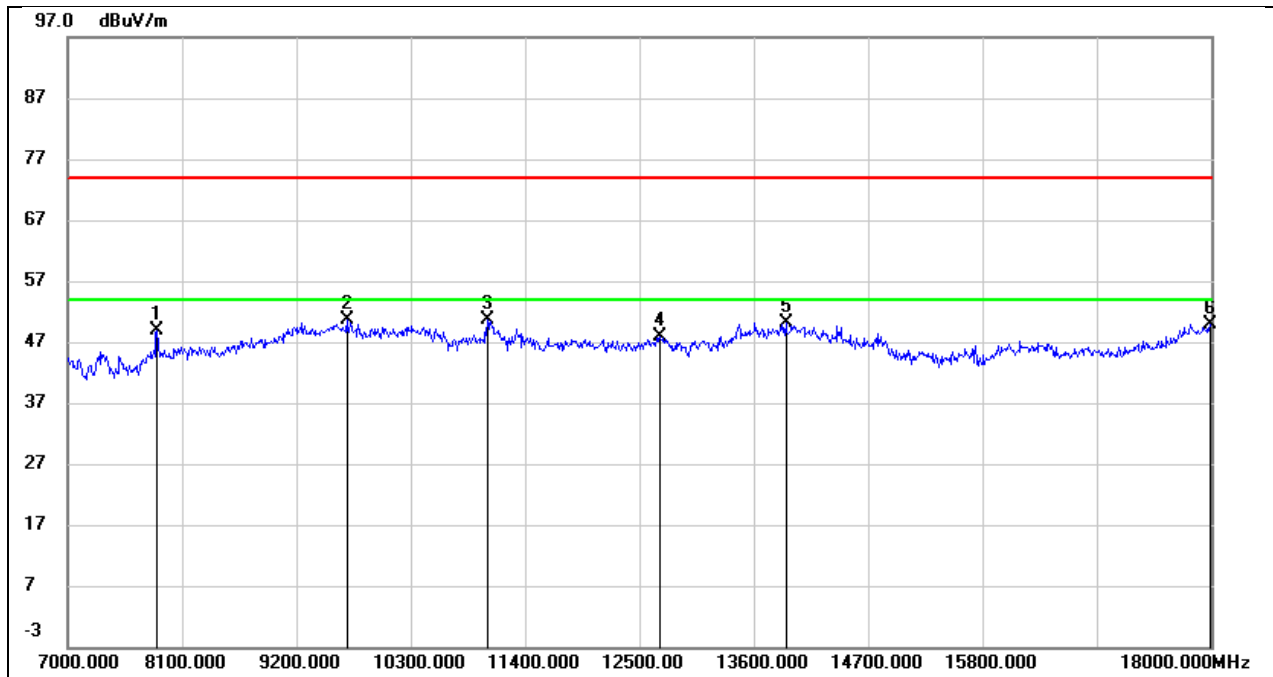

No.	Frequency (MHz)	Reading (dBuV)	Correct (dB/m)	Result (dBuV/m)	Limit (dBuV/m)	Margin (dB)	Remark
1	7858.000	40.92	8.02	48.94	74.00	-25.06	peak
2	9684.000	36.91	13.60	50.51	74.00	-23.49	peak
3	11037.000	35.37	15.27	50.64	74.00	-23.36	peak
4	12698.000	28.20	19.56	47.76	74.00	-26.24	peak
5	13908.000	26.90	23.24	50.14	74.00	-23.86	peak
6	17989.000	20.45	29.49	49.94	74.00	-24.06	peak

Test Mode:	802.11n HT20	Frequency(MHz):	5240
Polarity:	Vertical	Test Voltage:	AC 120V_60Hz

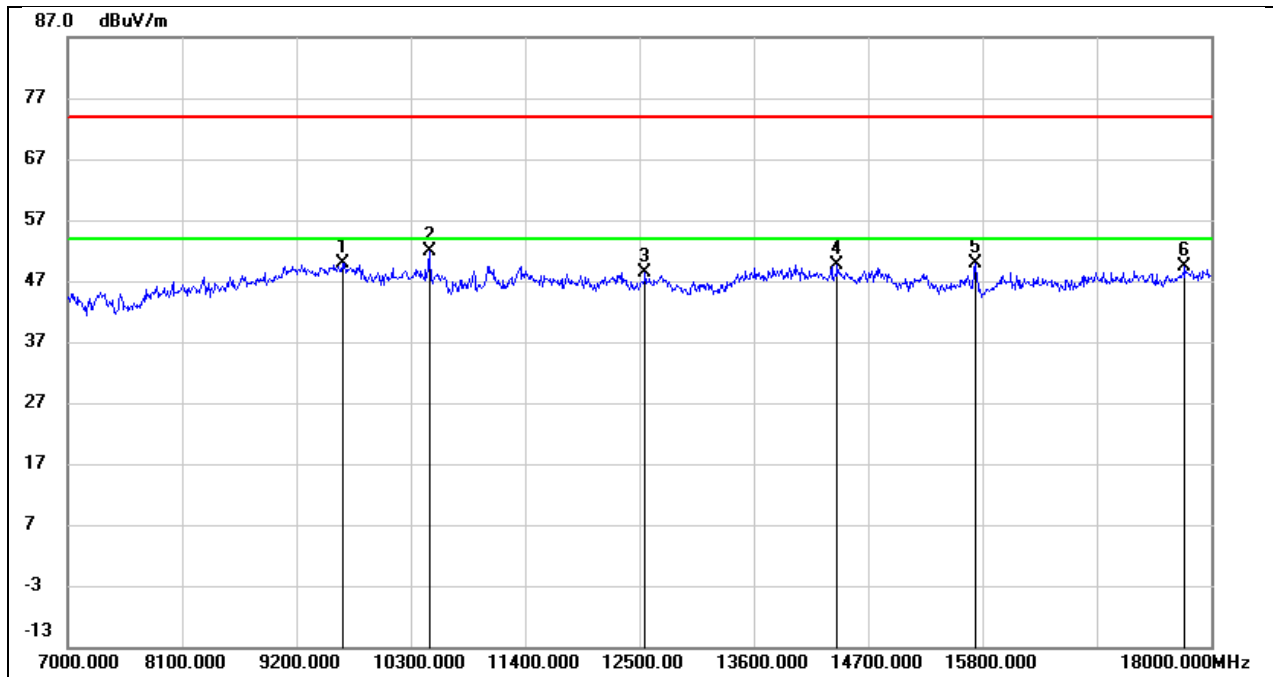

No.	Frequency (MHz)	Reading (dBuV)	Correct (dB/m)	Result (dBuV/m)	Limit (dBuV/m)	Margin (dB)	Remark
1	9640.000	36.59	13.33	49.92	74.00	-24.08	peak
2	10476.000	38.60	13.26	51.86	74.00	-22.14	peak
3	12555.000	30.17	18.15	48.32	74.00	-25.68	peak
4	14403.000	28.71	21.00	49.71	74.00	-24.29	peak
5	15734.000	28.44	21.39	49.83	74.00	-24.17	peak
6	17747.000	23.44	25.89	49.33	74.00	-24.67	peak

Test Mode:	802.11n HT20	Frequency(MHz):	5260
Polarity:	Horizontal	Test Voltage:	AC 120V_60Hz

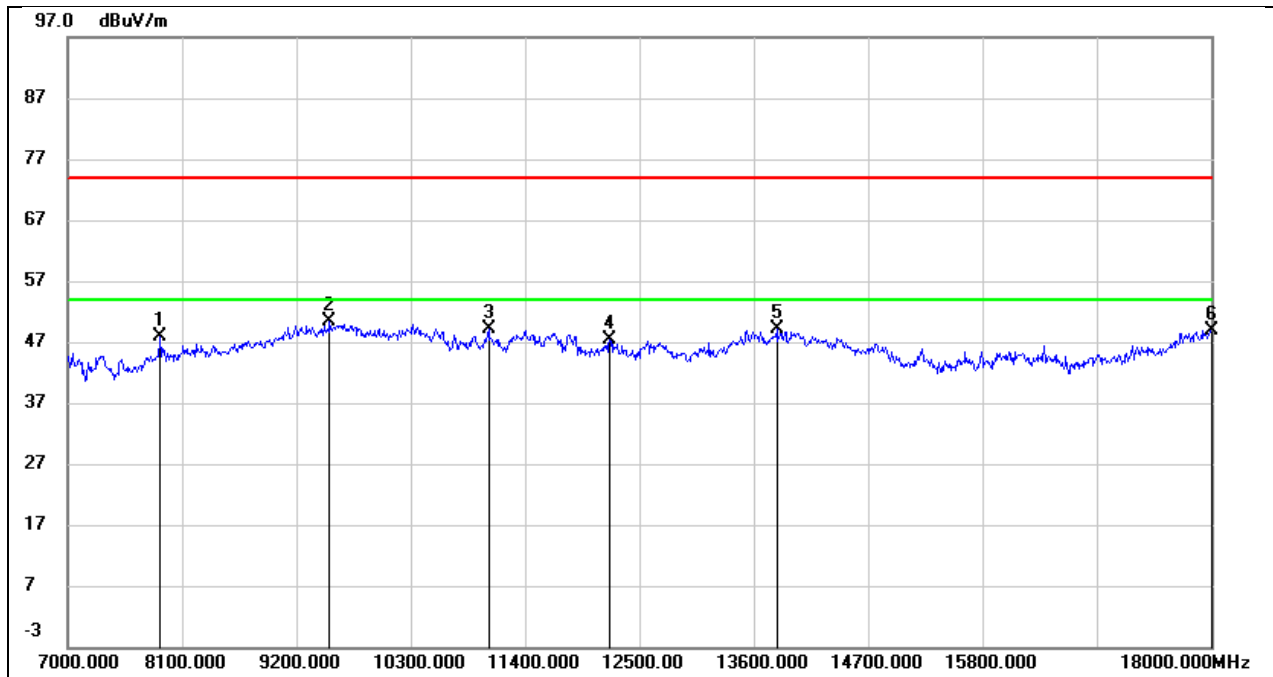

No.	Frequency (MHz)	Reading (dBuV)	Correct (dB/m)	Result (dBuV/m)	Limit (dBuV/m)	Margin (dB)	Remark
1	7891.000	39.92	8.04	47.96	74.00	-26.04	peak
2	9519.000	37.35	12.97	50.32	74.00	-23.68	peak
3	11048.000	33.90	15.33	49.23	74.00	-24.77	peak
4	12214.000	28.55	18.73	47.28	74.00	-26.72	peak
5	13820.000	26.23	22.88	49.11	74.00	-24.89	peak
6	18000.000	19.26	29.61	48.87	74.00	-25.13	peak

Test Mode:	802.11n HT20	Frequency(MHz):	5260
Polarity:	Vertical	Test Voltage:	AC 120V_60Hz

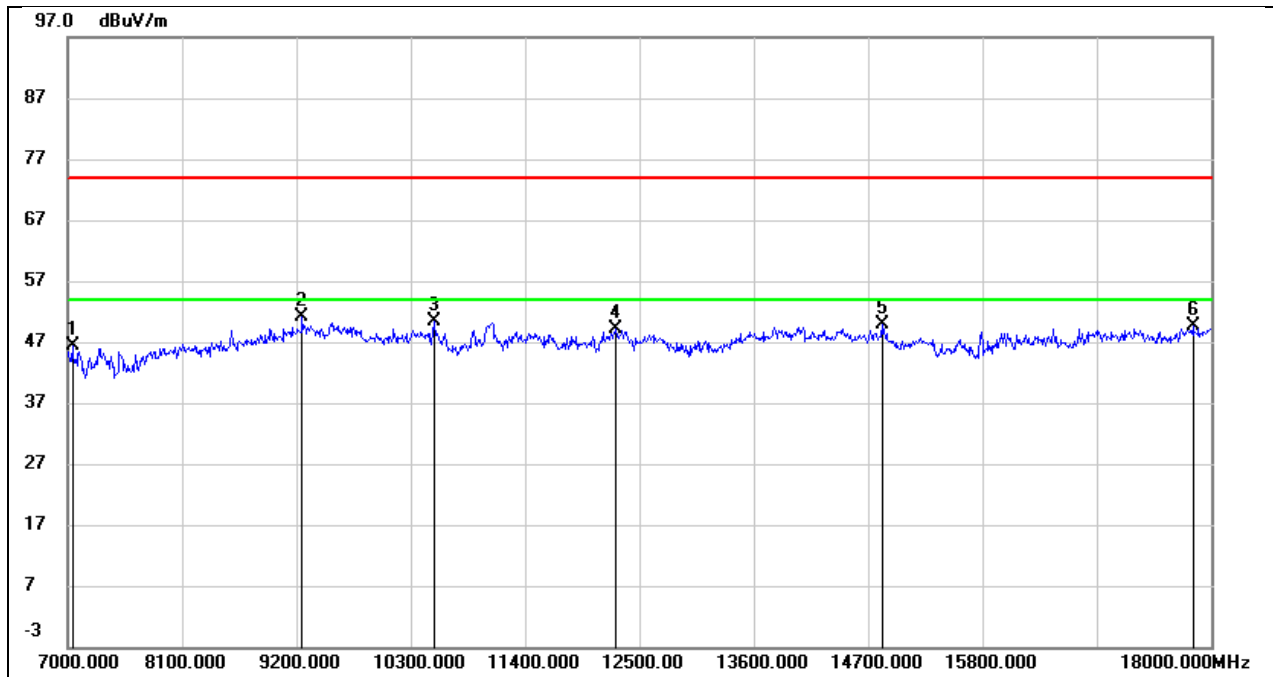

No.	Frequency (MHz)	Reading (dBuV)	Correct (dB/m)	Result (dBuV/m)	Limit (dBuV/m)	Margin (dB)	Remark
1	7044.000	38.25	8.08	46.33	74.00	-27.67	peak
2	9255.000	39.23	11.93	51.16	74.00	-22.84	peak
3	10520.000	36.91	13.36	50.27	74.00	-23.73	peak
4	12269.000	31.32	17.80	49.12	74.00	-24.88	peak
5	14832.000	29.42	20.50	49.92	74.00	-24.08	peak
6	17824.000	23.38	26.31	49.69	74.00	-24.31	peak

Test Mode:	802.11n HT20	Frequency(MHz):	5280
Polarity:	Horizontal	Test Voltage:	AC 120V_60Hz

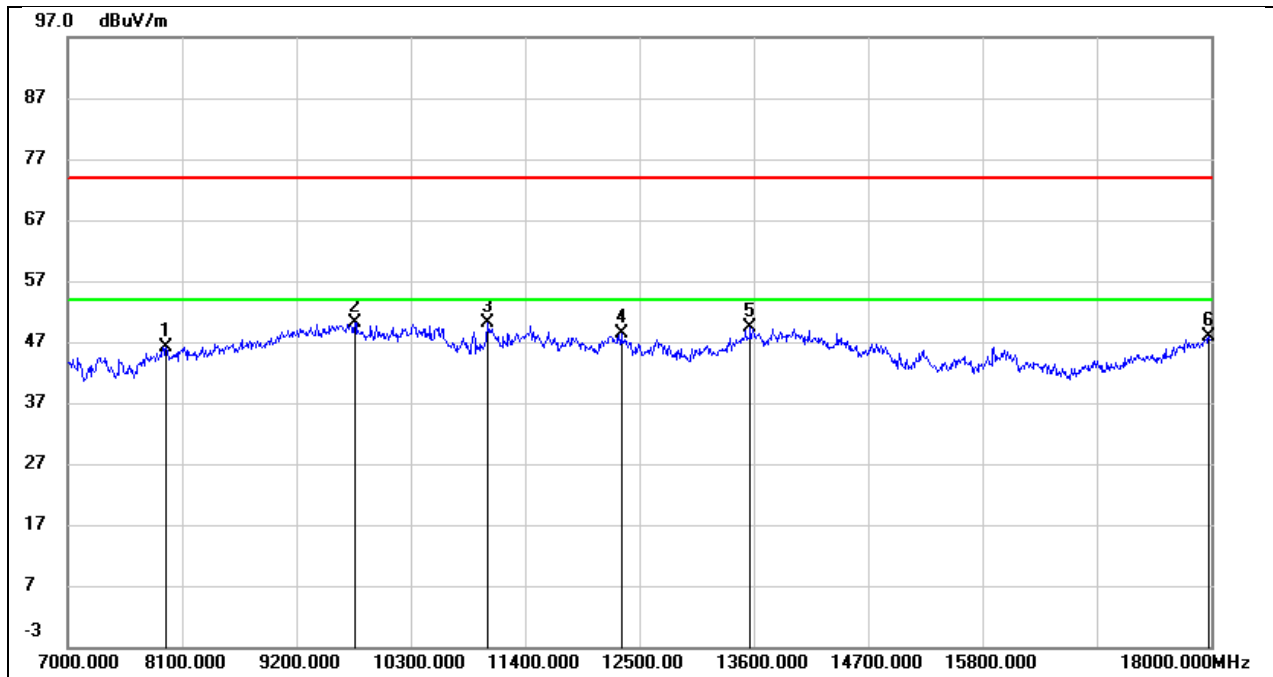

No.	Frequency (MHz)	Reading (dBuV)	Correct (dB/m)	Result (dBuV/m)	Limit (dBuV/m)	Margin (dB)	Remark
1	7946.000	38.07	8.06	46.13	74.00	-27.87	peak
2	9761.000	36.37	13.73	50.10	74.00	-23.90	peak
3	11037.000	34.92	15.27	50.19	74.00	-23.81	peak
4	12324.000	29.51	18.88	48.39	74.00	-25.61	peak
5	13567.000	27.23	22.16	49.39	74.00	-24.61	peak
6	17978.000	18.46	29.38	47.84	74.00	-26.16	peak

Test Mode:	802.11n HT20	Frequency(MHz):	5280
Polarity:	Vertical	Test Voltage:	AC 120V_60Hz

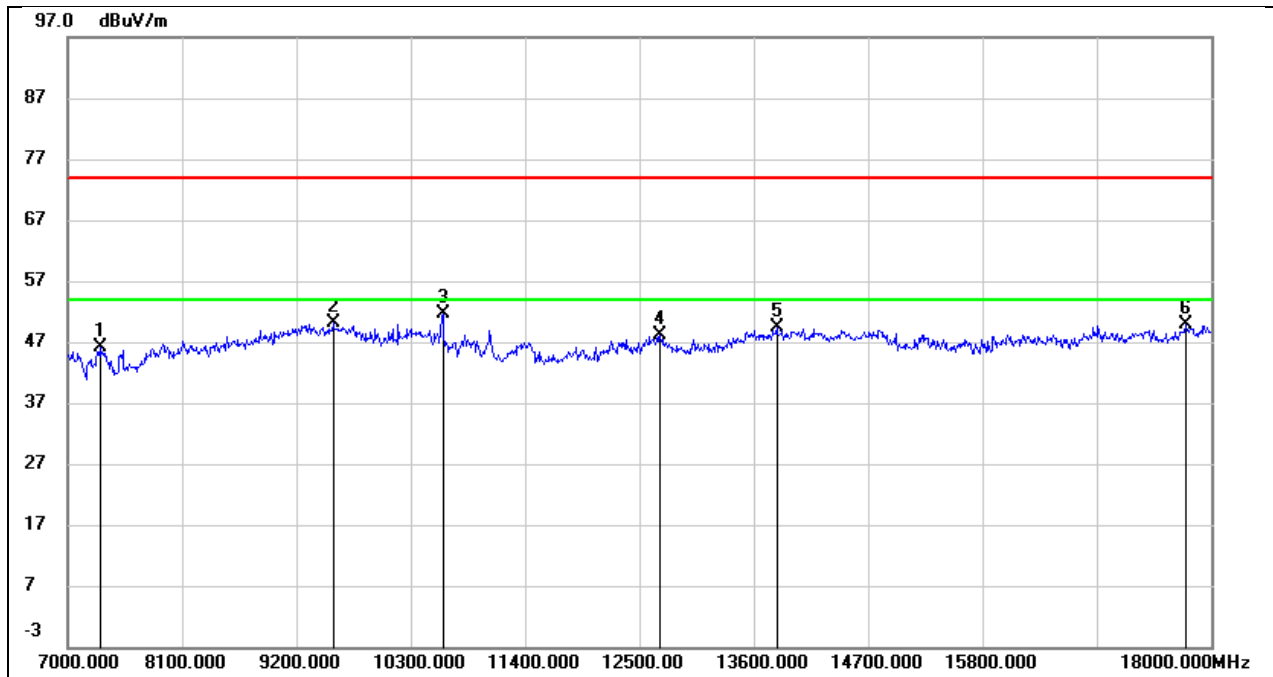

No.	Frequency (MHz)	Reading (dBuV)	Correct (dB/m)	Result (dBuV/m)	Limit (dBuV/m)	Margin (dB)	Remark
1	7308.000	37.75	8.29	46.04	74.00	-27.96	peak
2	9552.000	36.98	13.10	50.08	74.00	-23.92	peak
3	10608.000	38.17	13.52	51.69	74.00	-22.31	peak
4	12698.000	29.56	18.54	48.10	74.00	-25.90	peak
5	13820.000	28.15	21.24	49.39	74.00	-24.61	peak
6	17758.000	23.99	25.94	49.93	74.00	-24.07	peak

Test Mode:	802.11n HT20	Frequency(MHz):	5320
Polarity:	Horizontal	Test Voltage:	AC 120V_60Hz

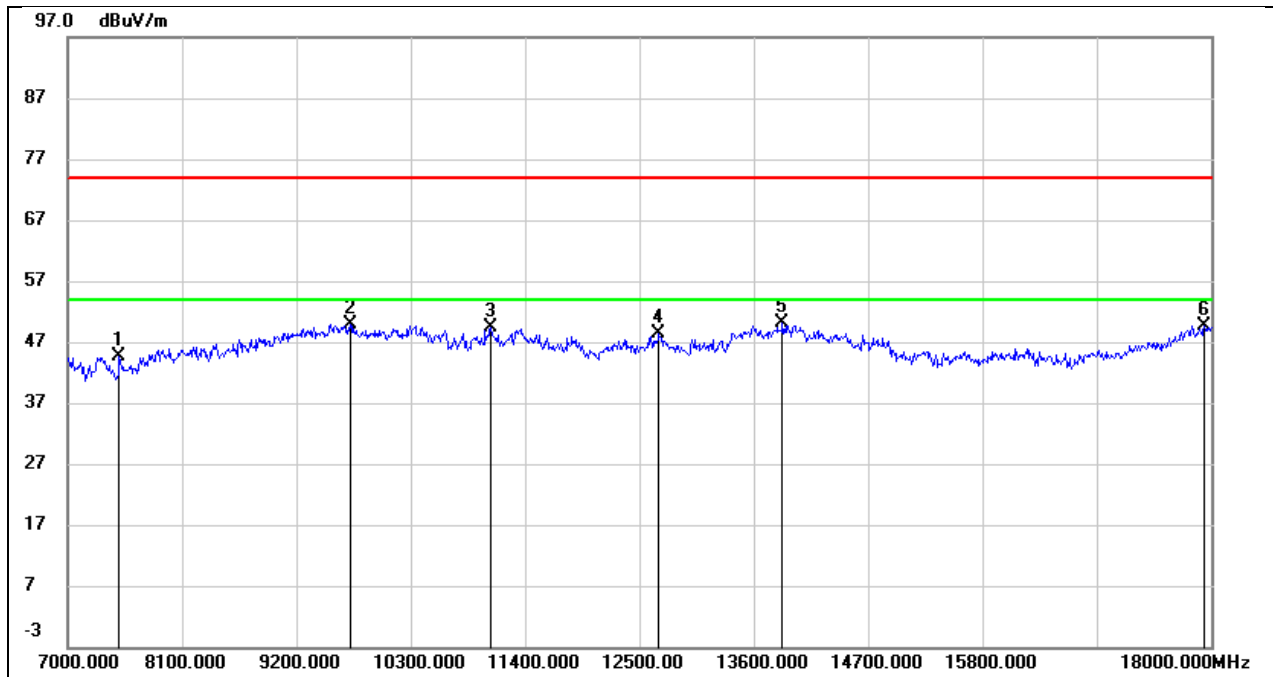

No.	Frequency (MHz)	Reading (dBuV)	Correct (dB/m)	Result (dBuV/m)	Limit (dBuV/m)	Margin (dB)	Remark
1	7495.000	36.80	7.84	44.64	74.00	-29.36	peak
2	9717.000	36.18	13.66	49.84	74.00	-24.16	peak
3	11070.000	33.95	15.44	49.39	74.00	-24.61	peak
4	12687.000	28.81	19.52	48.33	74.00	-25.67	peak
5	13875.000	26.95	23.11	50.06	74.00	-23.94	peak
6	17934.000	20.72	28.91	49.63	74.00	-24.37	peak



Test Mode:	802.11n HT20	Frequency(MHz):	5320
Polarity:	Vertical	Test Voltage:	AC 120V_60Hz

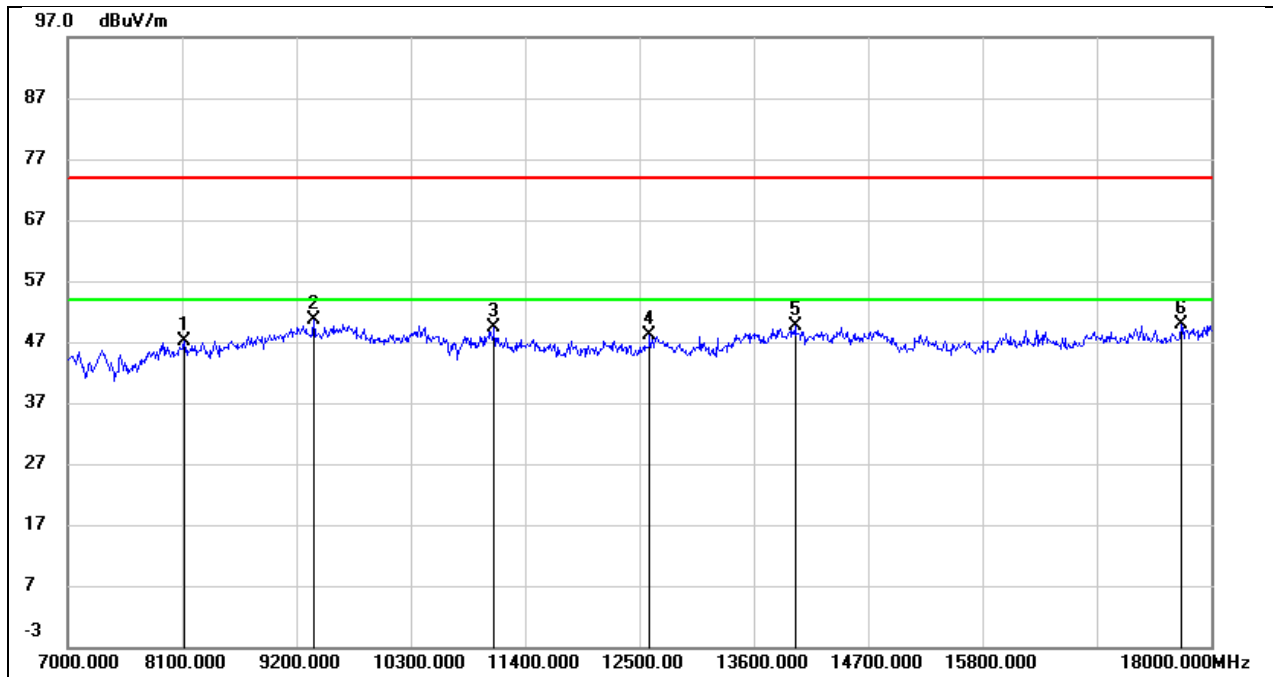

No.	Frequency (MHz)	Reading (dBuV)	Correct (dB/m)	Result (dBuV/m)	Limit (dBuV/m)	Margin (dB)	Remark
1	8122.000	38.28	8.77	47.05	74.00	-26.95	peak
2	9365.000	38.36	12.20	50.56	74.00	-23.44	peak
3	11103.000	34.61	14.68	49.29	74.00	-24.71	peak
4	12599.000	29.92	18.20	48.12	74.00	-25.88	peak
5	13996.000	27.56	21.99	49.55	74.00	-24.45	peak
6	17714.000	24.16	25.71	49.87	74.00	-24.13	peak

Test Mode:	802.11n HT20	Frequency(MHz):	5500
Polarity:	Horizontal	Test Voltage:	AC 120V_60Hz

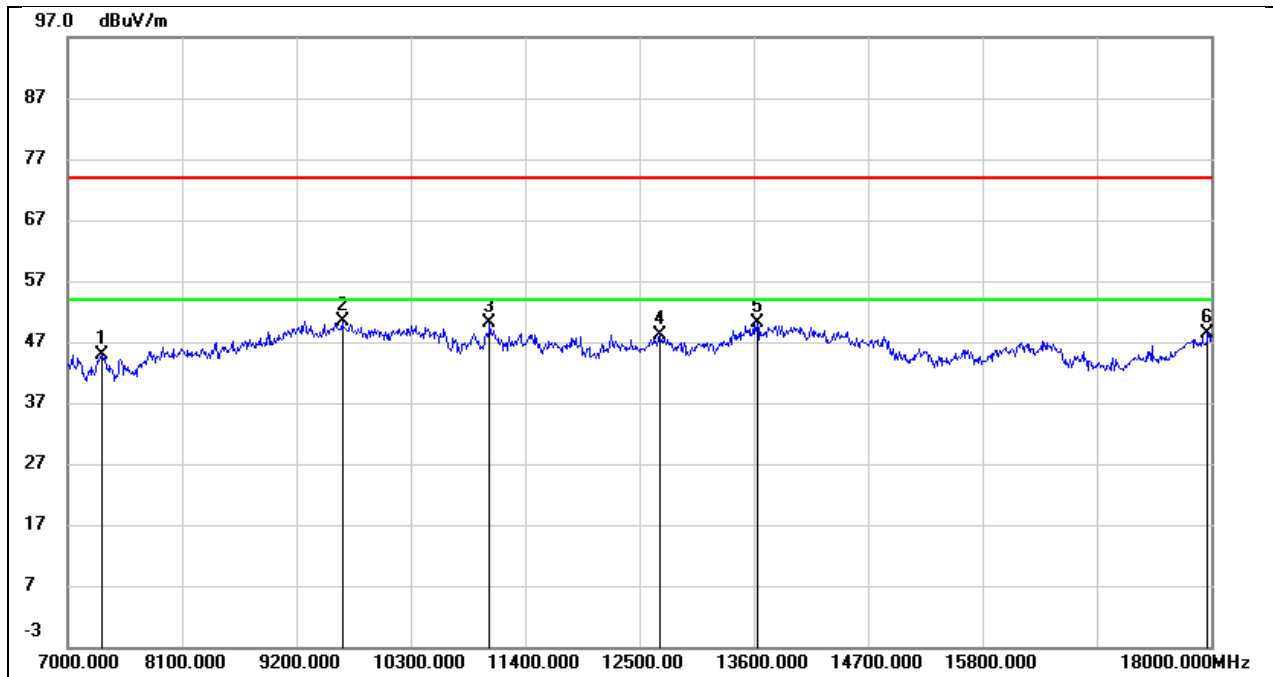

No.	Frequency (MHz)	Reading (dBuV)	Correct (dB/m)	Result (dBuV/m)	Limit (dBuV/m)	Margin (dB)	Remark
1	7330.000	37.28	7.66	44.94	74.00	-29.06	peak
2	9640.000	36.76	13.53	50.29	74.00	-23.71	peak
3	11059.000	34.73	15.39	50.12	74.00	-23.88	peak
4	12698.000	28.58	19.56	48.14	74.00	-25.86	peak
5	13633.000	27.78	22.31	50.09	74.00	-23.91	peak
6	17967.000	19.11	29.26	48.37	74.00	-25.63	peak

Test Mode:	802.11n HT20	Frequency(MHz):	5500
Polarity:	Vertical	Test Voltage:	AC 120V_60Hz

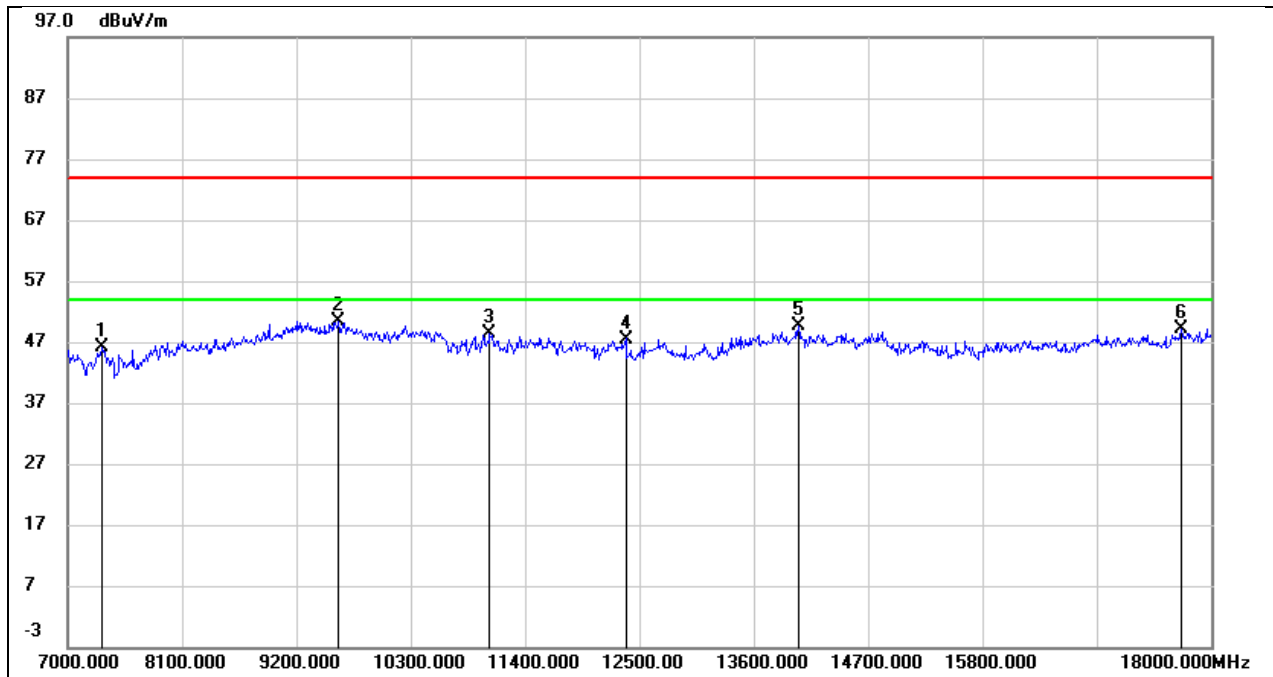

No.	Frequency (MHz)	Reading (dBuV)	Correct (dB/m)	Result (dBuV/m)	Limit (dBuV/m)	Margin (dB)	Remark
1	7330.000	37.84	8.30	46.14	74.00	-27.86	peak
2	9607.000	37.01	13.33	50.34	74.00	-23.66	peak
3	11059.000	33.89	14.51	48.40	74.00	-25.60	peak
4	12368.000	29.52	17.98	47.50	74.00	-26.50	peak
5	14029.000	27.73	21.96	49.69	74.00	-24.31	peak
6	17714.000	23.38	25.71	49.09	74.00	-24.91	peak

Test Mode:	802.11n HT20	Frequency(MHz):	5580
Polarity:	Horizontal	Test Voltage:	AC 120V_60Hz

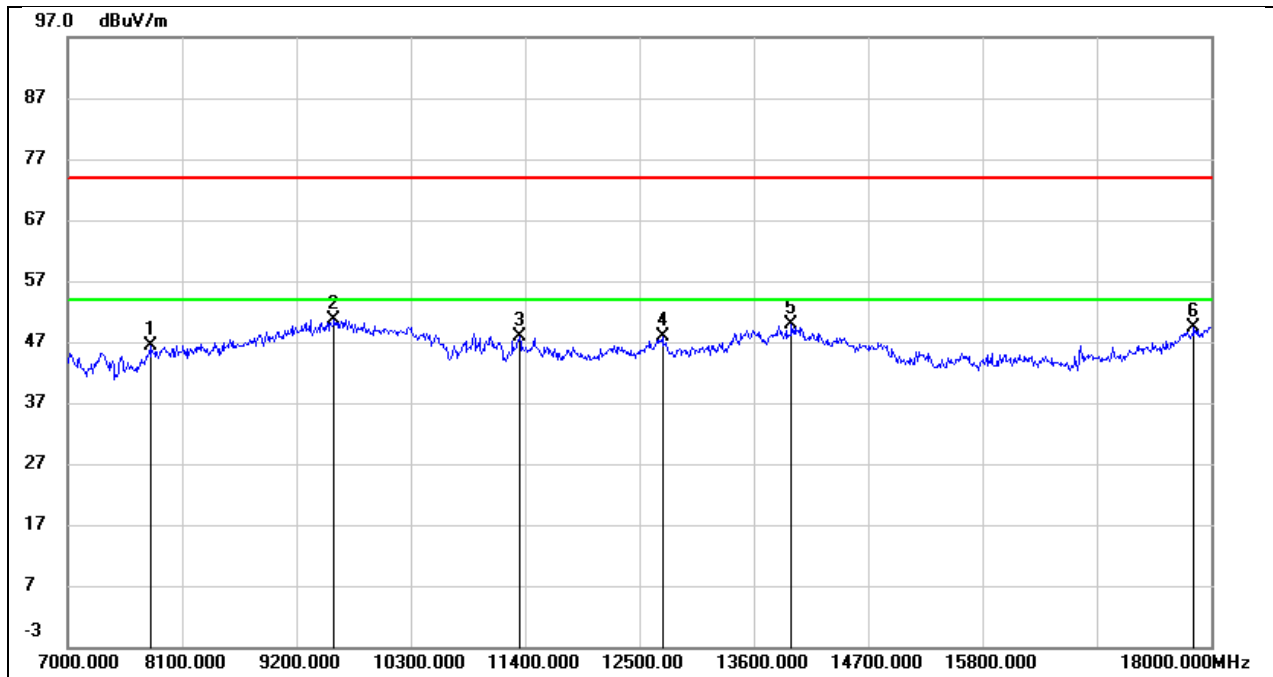

No.	Frequency (MHz)	Reading (dBuV)	Correct (dB/m)	Result (dBuV/m)	Limit (dBuV/m)	Margin (dB)	Remark
1	7792.000	38.26	8.01	46.27	74.00	-27.73	peak
2	9563.000	37.52	13.23	50.75	74.00	-23.25	peak
3	11345.000	30.76	17.04	47.80	74.00	-26.20	peak
4	12720.000	28.35	19.65	48.00	74.00	-26.00	peak
5	13963.000	26.38	23.46	49.84	74.00	-24.16	peak
6	17835.000	21.56	27.86	49.42	74.00	-24.58	peak

Test Mode:	802.11n HT20	Frequency(MHz):	5580
Polarity:	Vertical	Test Voltage:	AC 120V_60Hz

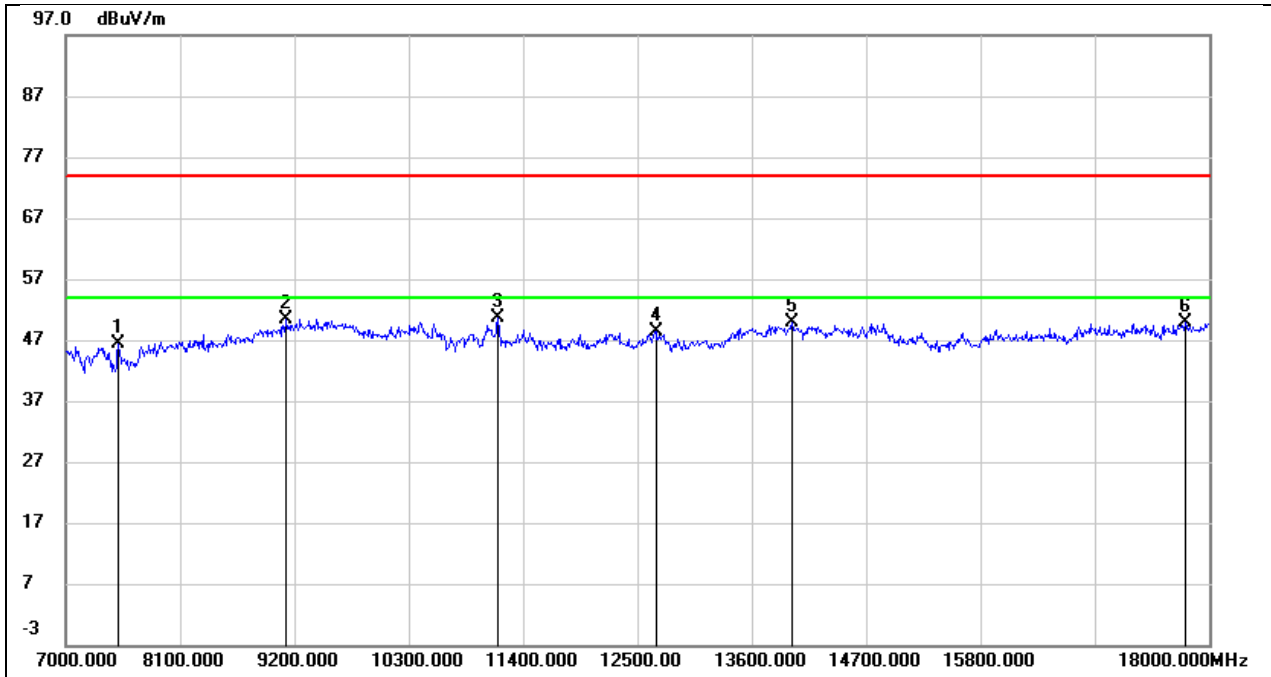

No.	Frequency (MHz)	Reading (dBuV)	Correct (dB/m)	Result (dBuV/m)	Limit (dBuV/m)	Margin (dB)	Remark
1	7506.000	38.02	8.34	46.36	74.00	-27.64	peak
2	9123.000	38.94	11.52	50.46	74.00	-23.54	peak
3	11158.000	35.63	14.91	50.54	74.00	-23.46	peak
4	12676.000	30.02	18.47	48.49	74.00	-25.51	peak
5	13985.000	28.01	21.95	49.96	74.00	-24.04	peak
6	17769.000	23.91	26.00	49.91	74.00	-24.09	peak

Test Mode:	802.11n HT20	Frequency(MHz):	5700
Polarity:	Horizontal	Test Voltage:	AC 120V_60Hz

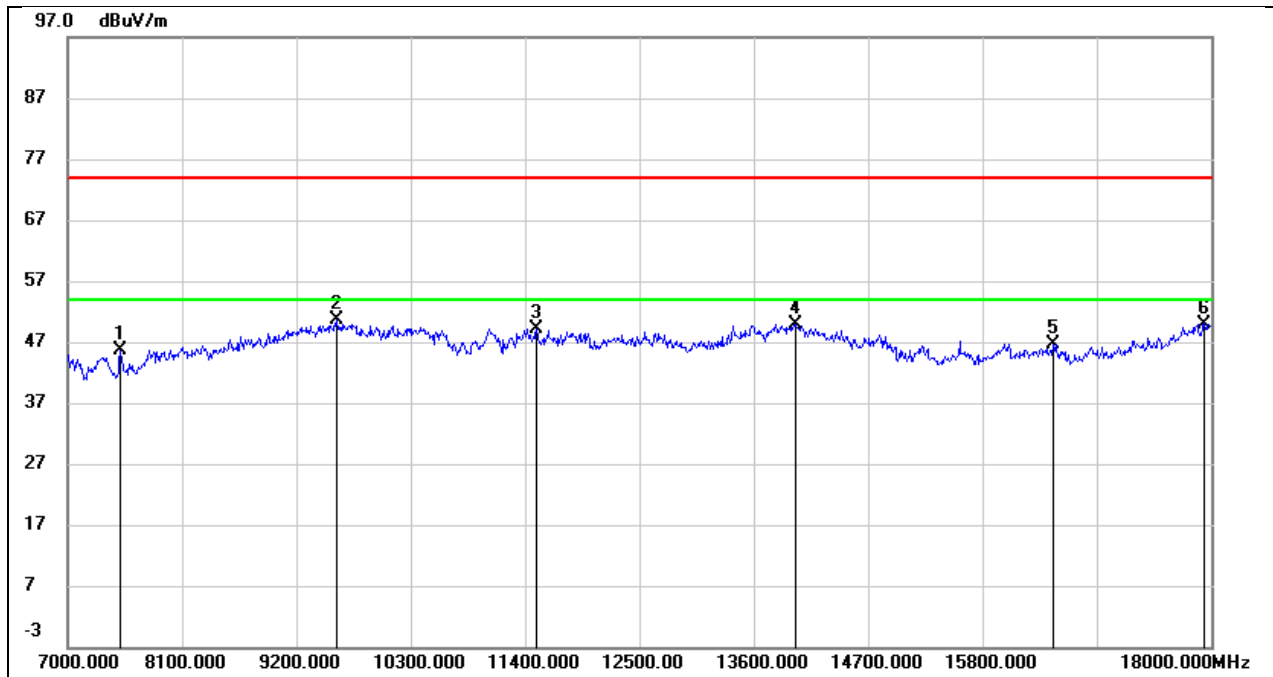

No.	Frequency (MHz)	Reading (dBuV)	Correct (dB/m)	Result (dBuV/m)	Limit (dBuV/m)	Margin (dB)	Remark
1	7506.000	37.67	7.84	45.51	74.00	-28.49	peak
2	9585.000	37.24	13.38	50.62	74.00	-23.38	peak
3	11510.000	31.39	17.86	49.25	74.00	-24.75	peak
4	13996.000	26.41	23.59	50.00	74.00	-24.00	peak
5	16482.000	24.83	21.85	46.68	74.00	-27.32	peak
6	17934.000	21.09	28.91	50.00	74.00	-24.00	peak

Test Mode:	802.11n HT20	Frequency(MHz):	5700
Polarity:	Vertical	Test Voltage:	AC 120V_60Hz

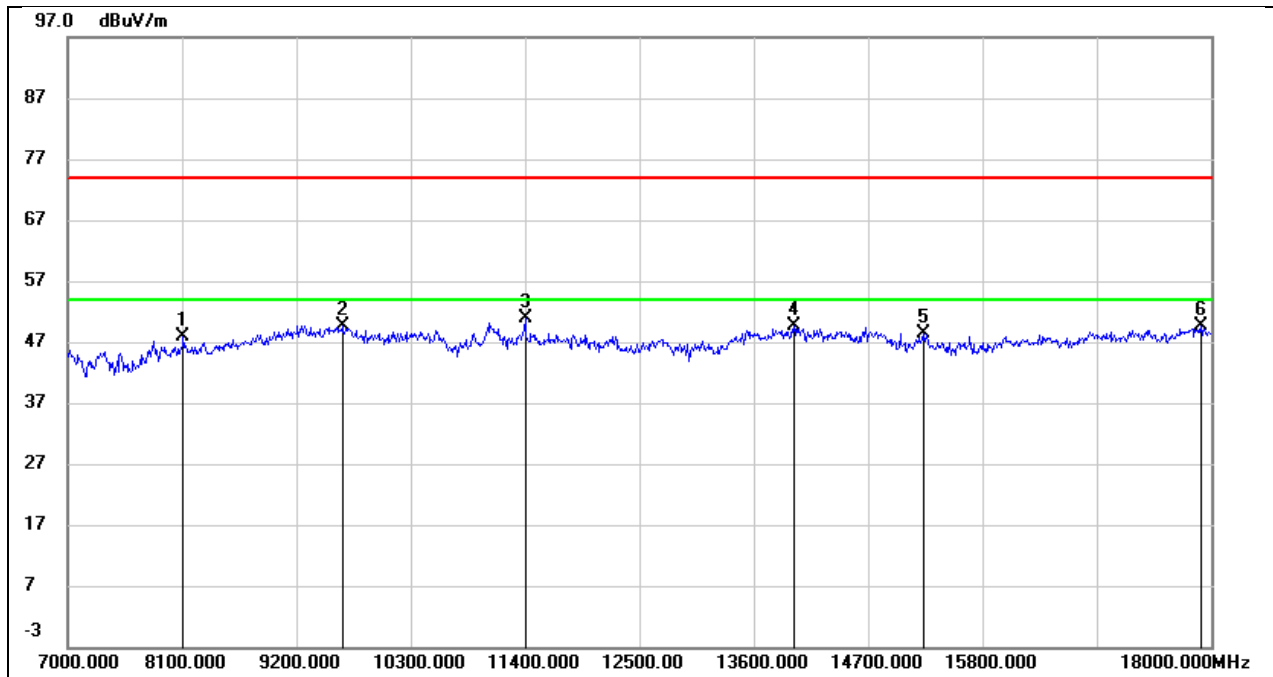

No.	Frequency (MHz)	Reading (dBuV)	Correct (dB/m)	Result (dBuV/m)	Limit (dBuV/m)	Margin (dB)	Remark
1	8111.000	39.05	8.75	47.80	74.00	-26.20	peak
2	9640.000	36.29	13.33	49.62	74.00	-24.38	peak
3	11400.000	34.84	16.00	50.84	74.00	-23.16	peak
4	13985.000	27.59	21.95	49.54	74.00	-24.46	peak
5	15228.000	28.43	20.03	48.46	74.00	-25.54	peak
6	17901.000	22.78	26.79	49.57	74.00	-24.43	peak

Test Mode:	802.11n HT20	Frequency(MHz):	5720
Polarity:	Horizontal	Test Voltage:	AC 120V_60Hz

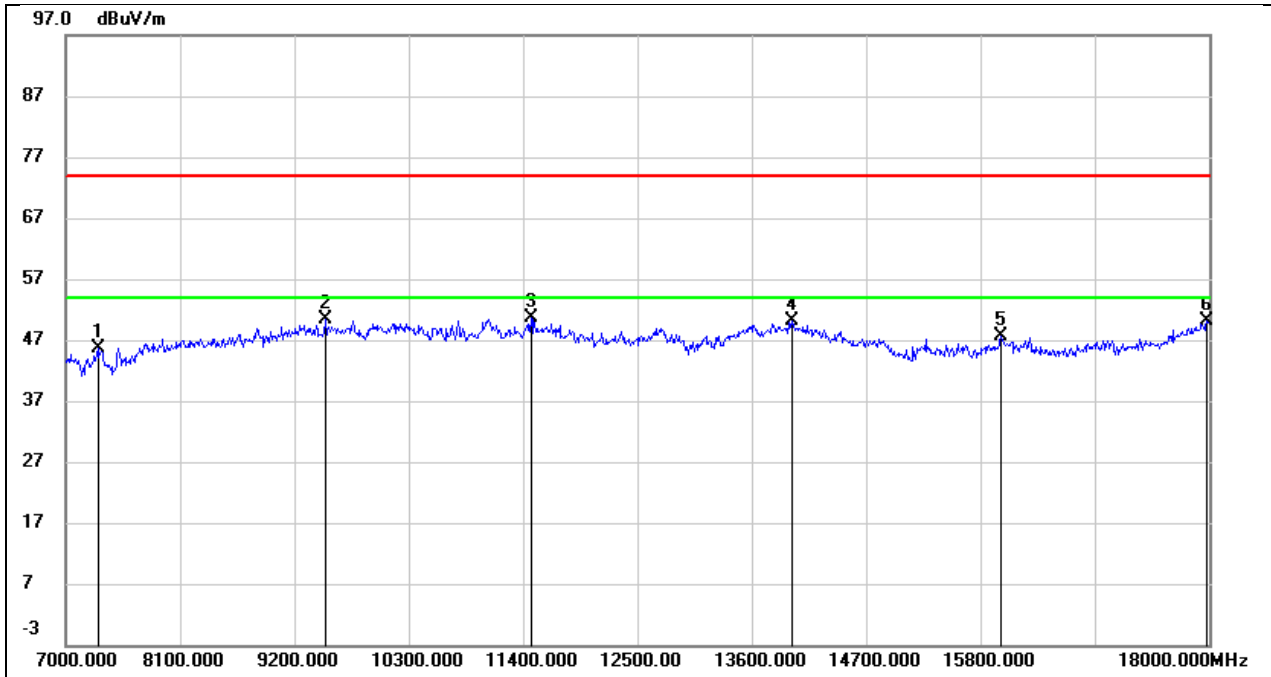

No.	Frequency (MHz)	Reading (dBuV)	Correct (dB/m)	Result (dBuV/m)	Limit (dBuV/m)	Margin (dB)	Remark
1	7308.000	38.08	7.64	45.72	74.00	-28.28	peak
2	9497.000	37.53	12.85	50.38	74.00	-23.62	peak
3	11477.000	32.97	17.73	50.70	74.00	-23.30	peak
4	13985.000	26.58	23.55	50.13	74.00	-23.87	peak
5	15998.000	27.07	20.46	47.53	74.00	-26.47	peak
6	17978.000	20.67	29.38	50.05	74.00	-23.95	peak



Test Mode:	802.11n HT20	Frequency(MHz):	5720
Polarity:	Vertical	Test Voltage:	AC 120V_60Hz

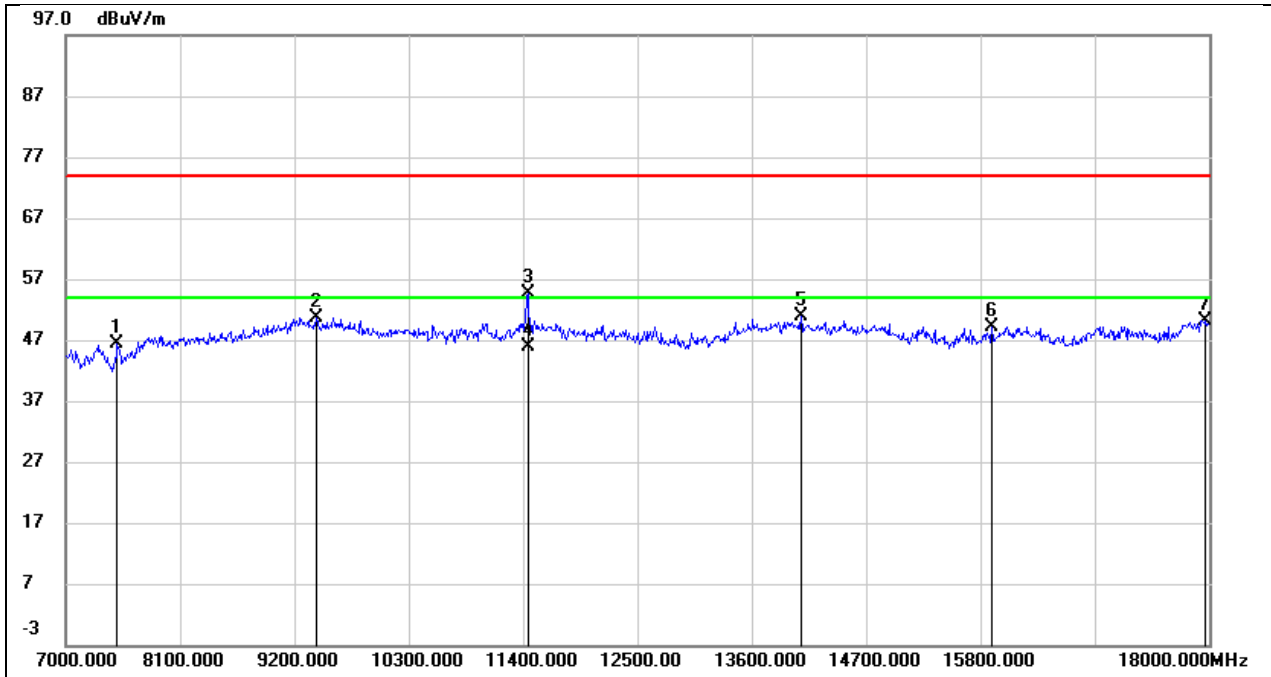

No.	Frequency (MHz)	Reading (dBuV)	Correct (dB/m)	Result (dBuV/m)	Limit (dBuV/m)	Margin (dB)	Remark
1	7495.000	38.05	8.35	46.40	74.00	-27.60	peak
2	9409.000	38.40	12.34	50.74	74.00	-23.26	peak
3	11444.000	38.48	16.15	54.63	74.00	-19.37	peak
4	11444.000	29.64	16.15	45.79	54.00	-8.21	AVG
5	14073.000	28.89	21.90	50.79	74.00	-23.21	peak
6	15910.000	26.86	22.31	49.17	74.00	-24.83	peak
7	17967.000	22.93	27.20	50.13	74.00	-23.87	peak

Test Mode:	802.11n HT20	Frequency(MHz):	5745
Polarity:	Horizontal	Test Voltage:	AC 120V_60Hz

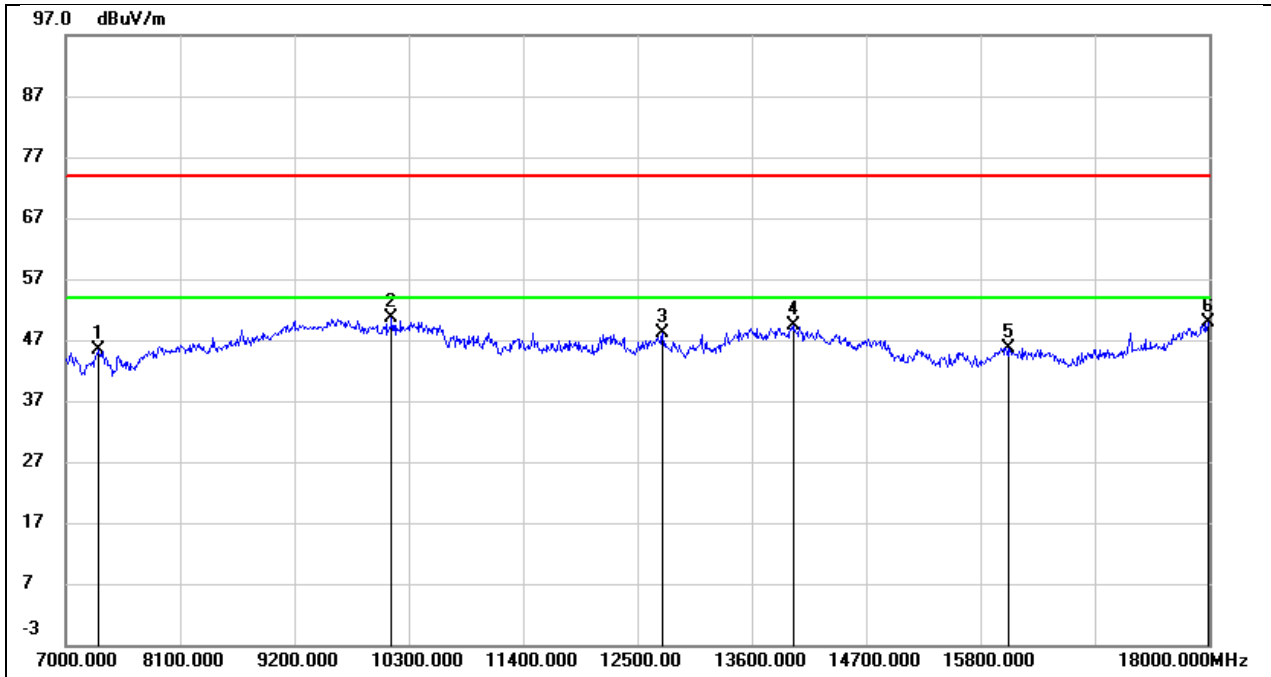

No.	Frequency (MHz)	Reading (dBuV)	Correct (dB/m)	Result (dBuV/m)	Limit (dBuV/m)	Margin (dB)	Remark
1	7319.000	37.61	7.66	45.27	74.00	-28.73	peak
2	10135.000	37.35	13.23	50.58	74.00	-23.42	peak
3	12742.000	28.33	19.75	48.08	74.00	-25.92	peak
4	13996.000	25.87	23.59	49.46	74.00	-24.54	peak
5	16075.000	24.63	21.06	45.69	74.00	-28.31	peak
6	17989.000	20.30	29.49	49.79	74.00	-24.21	peak

Test Mode:	802.11n HT20	Frequency(MHz):	5745
Polarity:	Vertical	Test Voltage:	AC 120V_60Hz

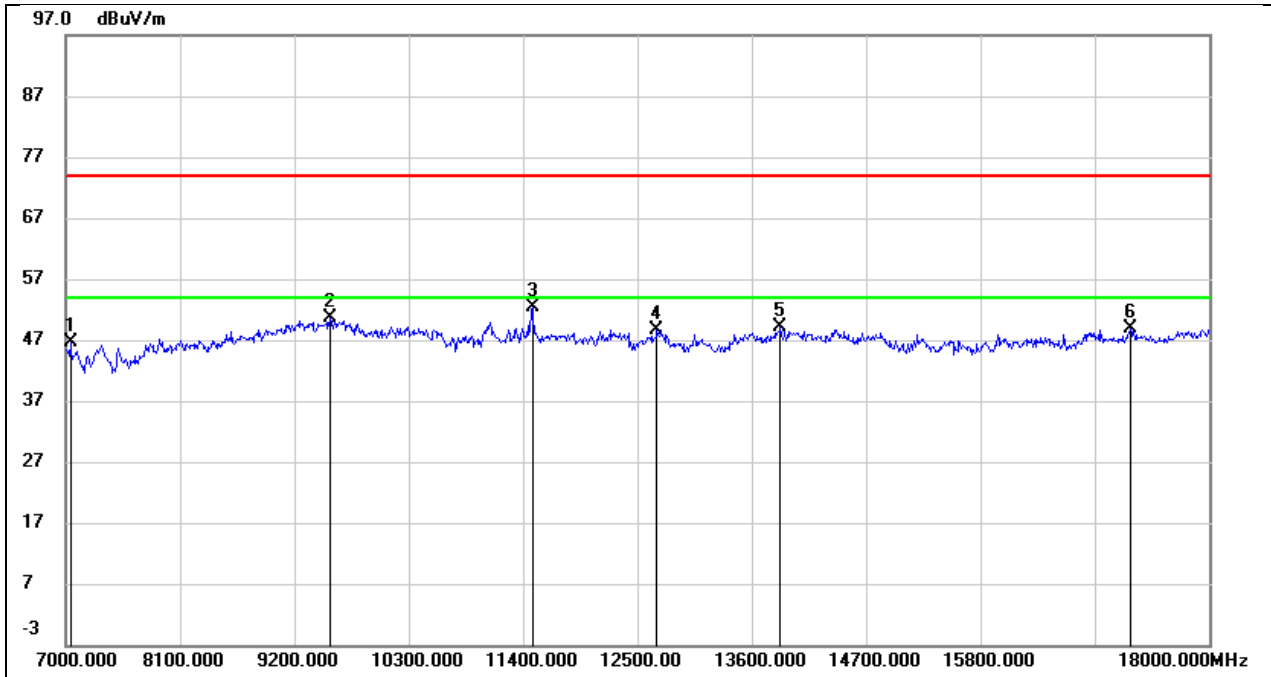

No.	Frequency (MHz)	Reading (dBuV)	Correct (dB/m)	Result (dBuV/m)	Limit (dBuV/m)	Margin (dB)	Remark
1	7044.000	38.49	8.08	46.57	74.00	-27.43	peak
2	9541.000	37.51	13.04	50.55	74.00	-23.45	peak
3	11488.000	36.17	16.29	52.46	74.00	-21.54	peak
4	12687.000	30.17	18.51	48.68	74.00	-25.32	peak
5	13875.000	27.65	21.49	49.14	74.00	-24.86	peak
6	17241.000	23.87	24.94	48.81	74.00	-25.19	peak

Test Mode:	802.11n HT20	Frequency(MHz):	5785
Polarity:	Horizontal	Test Voltage:	AC 120V_60Hz

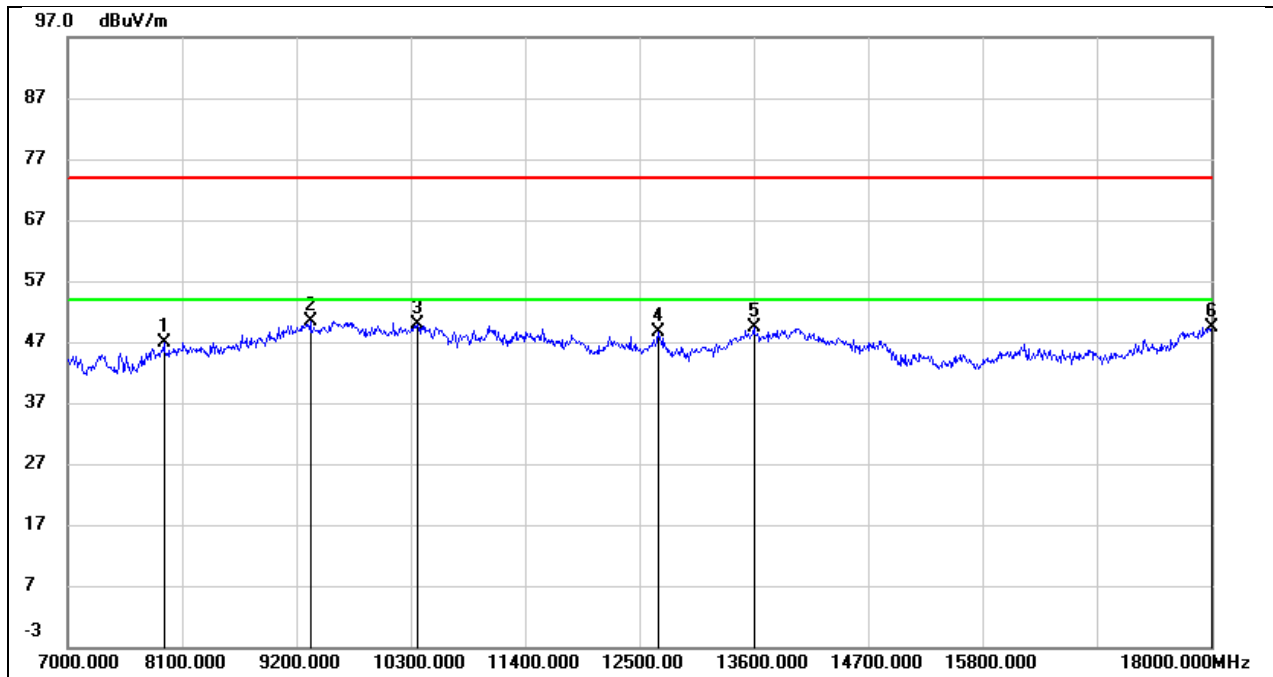

No.	Frequency (MHz)	Reading (dBuV)	Correct (dB/m)	Result (dBuV/m)	Limit (dBuV/m)	Margin (dB)	Remark
1	7924.000	38.84	8.05	46.89	74.00	-27.11	peak
2	9332.000	38.43	11.99	50.42	74.00	-23.58	peak
3	10366.000	36.60	13.32	49.92	74.00	-24.08	peak
4	12676.000	29.04	19.48	48.52	74.00	-25.48	peak
5	13600.000	27.18	22.22	49.40	74.00	-24.60	peak
6	18000.000	19.84	29.61	49.45	74.00	-24.55	peak

Test Mode:	802.11n HT20	Frequency(MHz):	5785
Polarity:	Vertical	Test Voltage:	AC 120V_60Hz

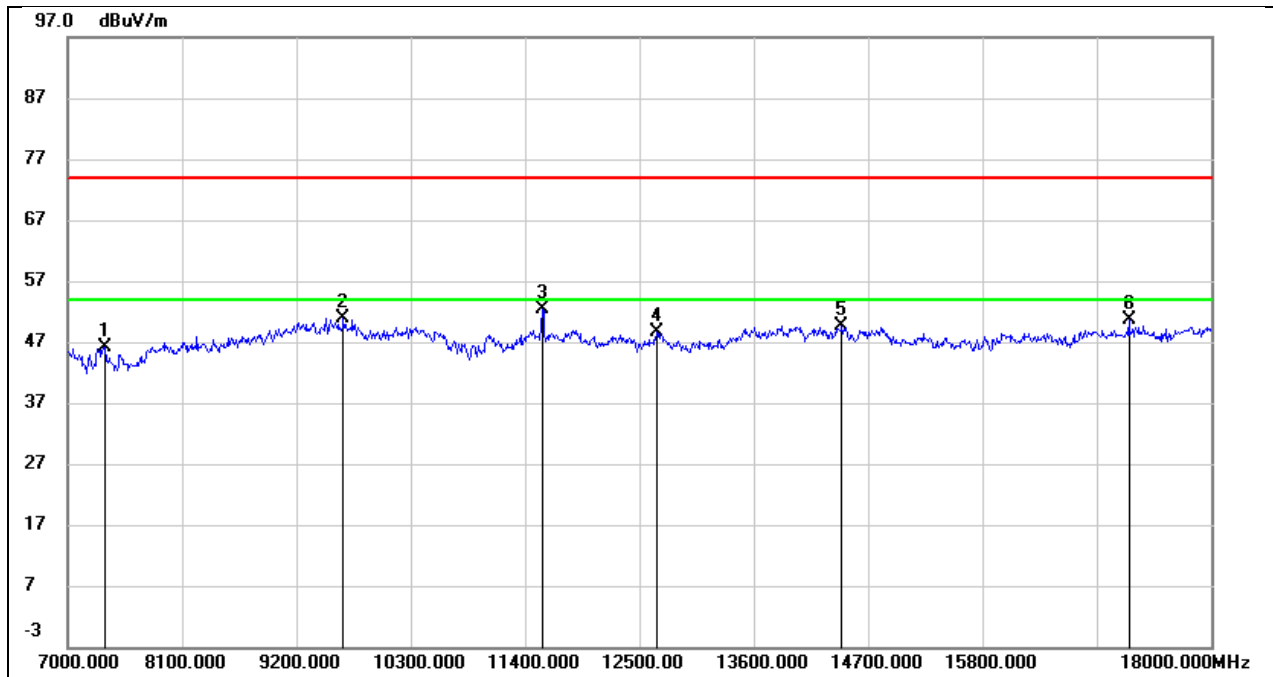

No.	Frequency (MHz)	Reading (dBuV)	Correct (dB/m)	Result (dBuV/m)	Limit (dBuV/m)	Margin (dB)	Remark
1	7363.000	37.82	8.31	46.13	74.00	-27.87	peak
2	9651.000	37.64	13.34	50.98	74.00	-23.02	peak
3	11565.000	35.78	16.56	52.34	74.00	-21.66	peak
4	12665.000	30.10	18.42	48.52	74.00	-25.48	peak
5	14447.000	28.66	20.97	49.63	74.00	-24.37	peak
6	17208.000	25.79	24.92	50.71	74.00	-23.29	peak

Test Mode:	802.11n HT20	Frequency(MHz):	5825
Polarity:	Horizontal	Test Voltage:	AC 120V_60Hz

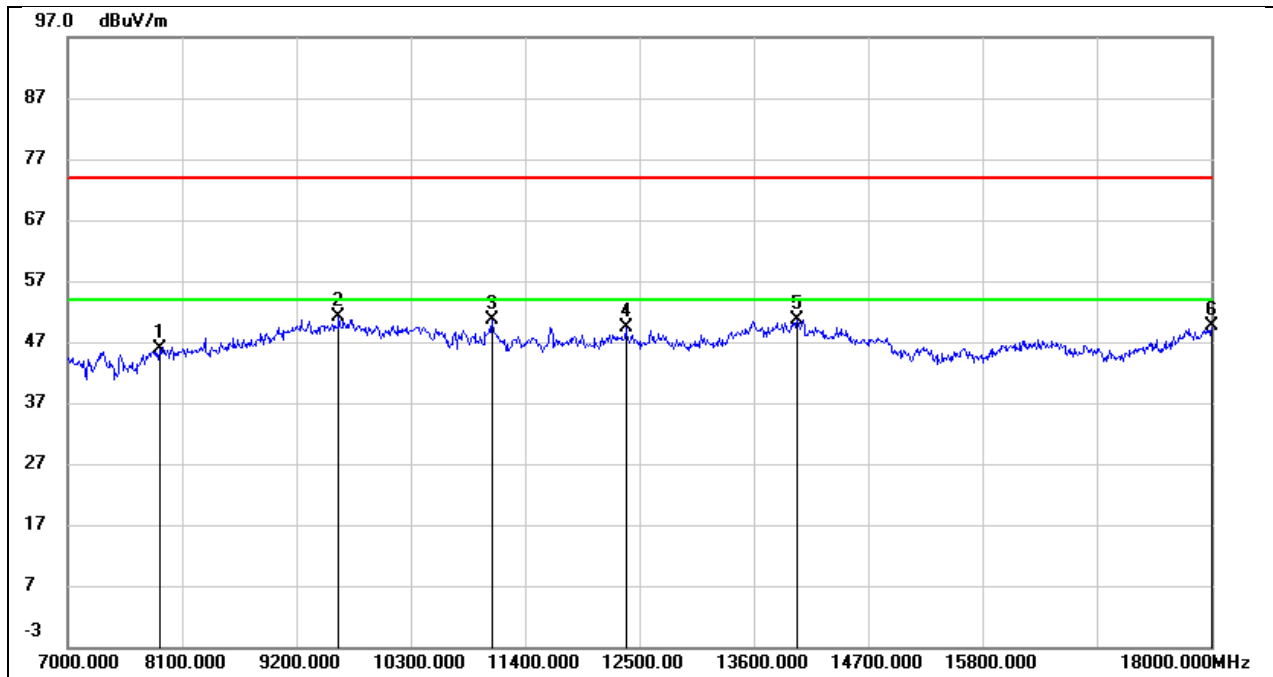

No.	Frequency (MHz)	Reading (dBuV)	Correct (dB/m)	Result (dBuV/m)	Limit (dBuV/m)	Margin (dB)	Remark
1	7880.000	37.78	8.03	45.81	74.00	-28.19	peak
2	9607.000	37.59	13.48	51.07	74.00	-22.93	peak
3	11081.000	35.23	15.51	50.74	74.00	-23.26	peak
4	12368.000	30.39	18.94	49.33	74.00	-24.67	peak
5	14018.000	27.18	23.54	50.72	74.00	-23.28	peak
6	18000.000	19.91	29.61	49.52	74.00	-24.48	peak

Test Mode:	802.11n HT20	Frequency(MHz):	5825
Polarity:	Vertical	Test Voltage:	AC 120V_60Hz

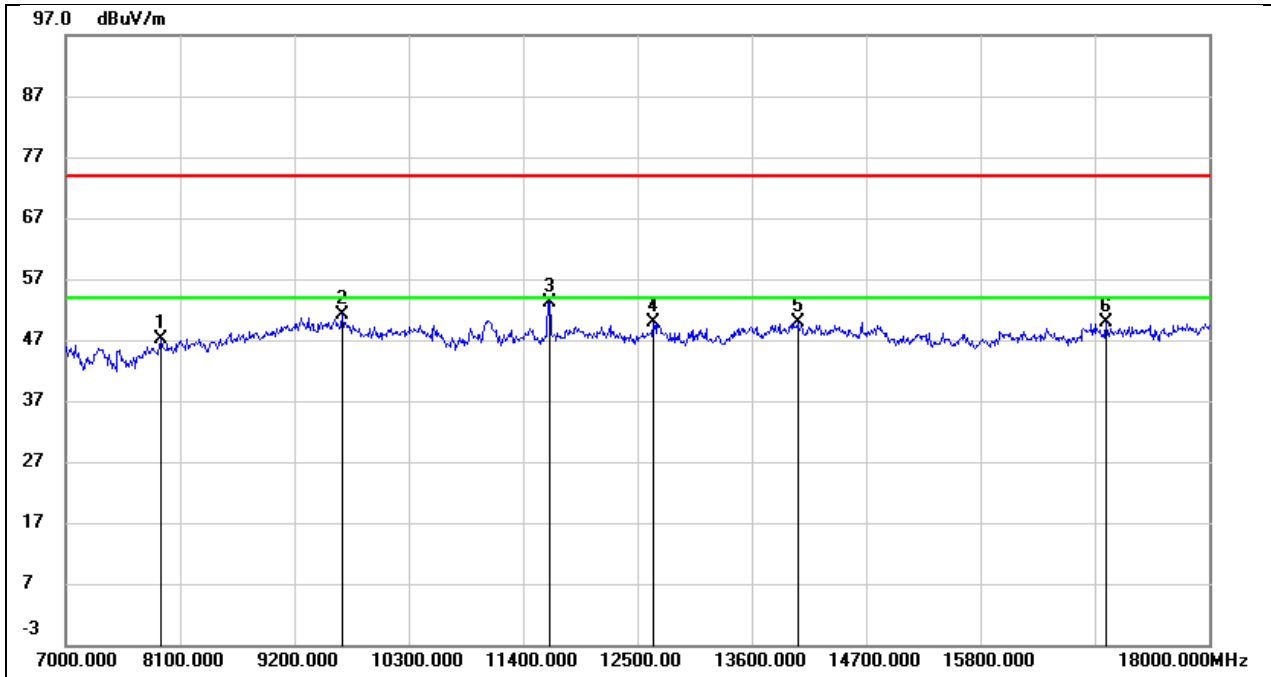

No.	Frequency (MHz)	Reading (dBuV)	Correct (dB/m)	Result (dBuV/m)	Limit (dBuV/m)	Margin (dB)	Remark
1	7913.000	38.57	8.55	47.12	74.00	-26.88	peak
2	9662.000	37.71	13.34	51.05	74.00	-22.95	peak
3	11653.000	36.39	16.68	53.07	74.00	-20.93	peak
4	12654.000	31.49	18.39	49.88	74.00	-24.12	peak
5	14040.000	27.94	21.95	49.89	74.00	-24.11	peak
6	17010.000	25.31	24.45	49.76	74.00	-24.24	peak

### 8.4. SPURIOUS EMISSIONS(9 KHZ~30 MHZ)

Test Mode:	802.11a20	Frequency(MHz):	5745
Polarity:	Horizontal	Test Voltage:	AC 120V_60Hz

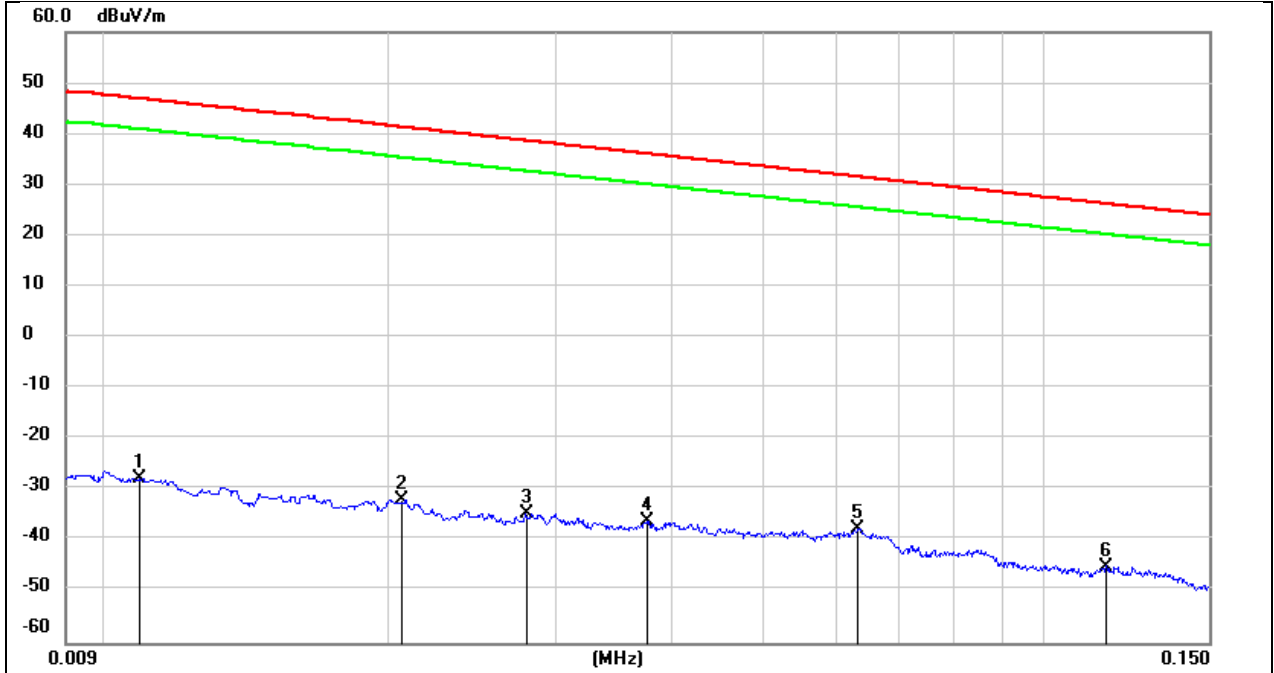

No.	Frequency (MHz)	Reading (dBuV)	Correct (dB/m)	Result (dBuV/m)	Limit (dBuV/m)	Margin (dB)	Remark
1	0.0108	73.51	-101.39	-27.88	46.93	-74.81	peak
2	0.0206	69.42	-101.35	-31.93	41.32	-73.25	peak
3	0.0280	66.79	-101.38	-34.59	38.66	-73.25	peak
4	0.0376	65.25	-101.42	-36.17	36.10	-72.27	peak
5	0.0632	63.88	-101.54	-37.66	31.59	-69.25	peak
6	0.1165	56.74	-101.74	-45.00	26.28	-71.28	peak



Test Mode:	802.11a20	Frequency(MHz):	5745
Polarity:	Horizontal	Test Voltage:	AC 120V_60Hz

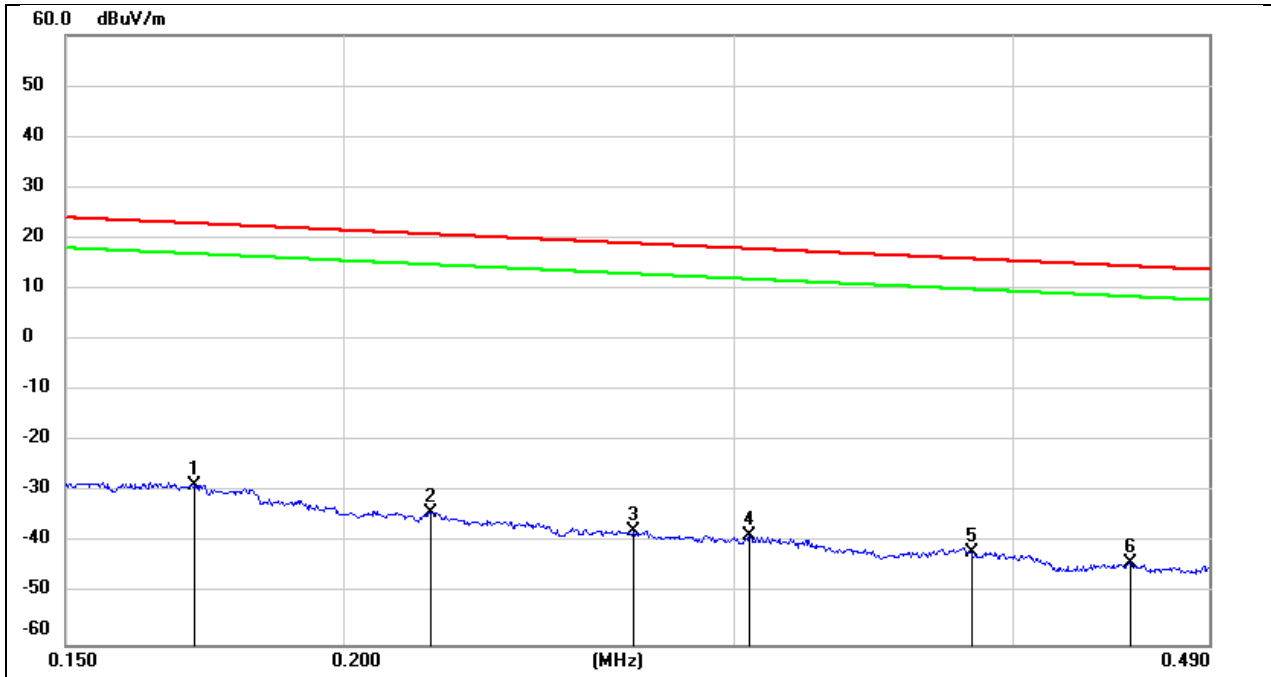

No.	Frequency (MHz)	Reading (dBuV)	Correct (dB/m)	Result (dBuV/m)	Limit (dBuV/m)	Margin (dB)	Remark
1	0.1715	73.11	-101.67	-28.56	22.92	-51.48	peak
2	0.2190	67.77	-101.75	-33.98	20.79	-54.77	peak
3	0.2701	64.31	-101.82	-37.51	18.97	-56.48	peak
4	0.3047	63.34	-101.86	-38.52	17.92	-56.44	peak
5	0.3830	60.20	-101.94	-41.74	15.94	-57.68	peak
6	0.4516	57.95	-102.01	-44.06	14.51	-58.57	peak

Test Mode:	802.11a20	Frequency(MHz):	5745
Polarity:	Horizontal	Test Voltage:	AC 120V_60Hz

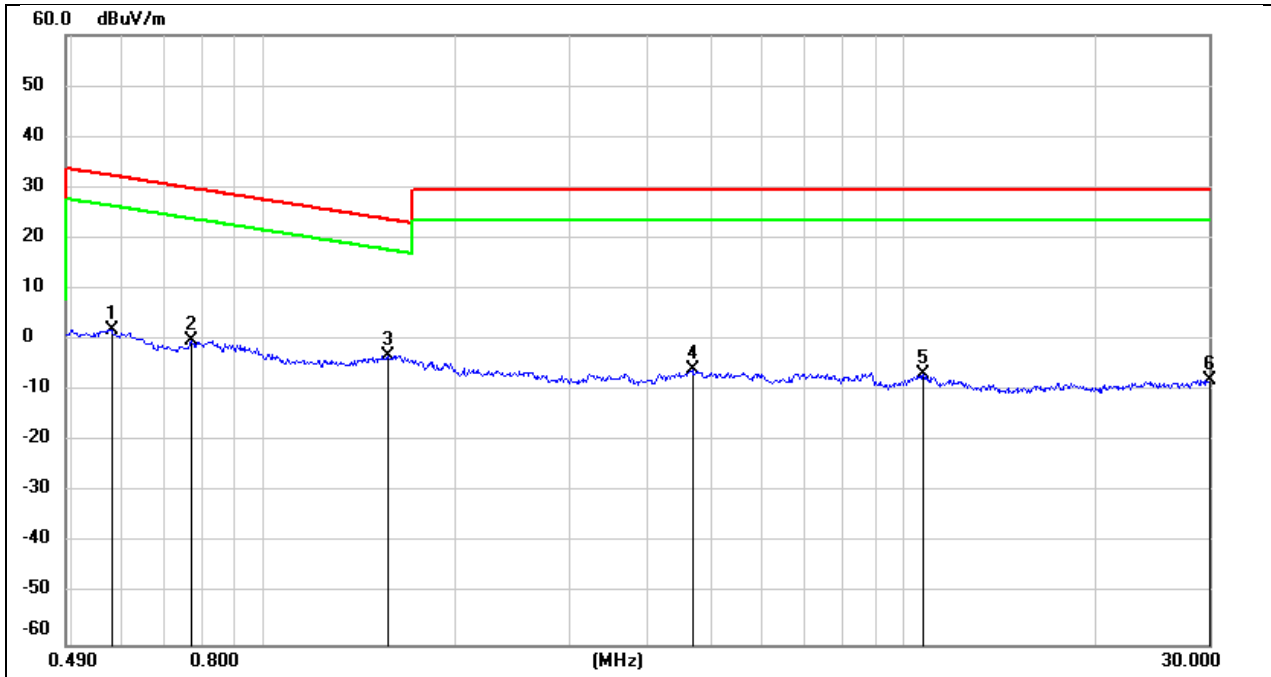

No.	Frequency (MHz)	Reading (dBuV)	Correct (dB/m)	Result (dBuV/m)	Limit (dBuV/m)	Margin (dB)	Remark
1	0.5785	63.90	-62.08	1.82	32.36	-30.54	peak
2	0.7700	61.91	-62.13	-0.22	29.87	-30.09	peak
3	1.5625	58.96	-62.02	-3.06	23.73	-26.79	peak
4	4.6802	55.56	-61.43	-5.87	29.54	-35.41	peak
5	10.7299	53.98	-60.83	-6.85	29.54	-36.39	peak
6	30.0000	51.98	-59.97	-7.99	29.54	-37.53	peak

### 8.5. SPURIOUS EMISSIONS(18 GHZ~26 GHZ)

Test Mode:	802.11a 20	Frequency(MHz):	5745
Polarity:	Horizontal	Test Voltage:	AC 120V_60Hz

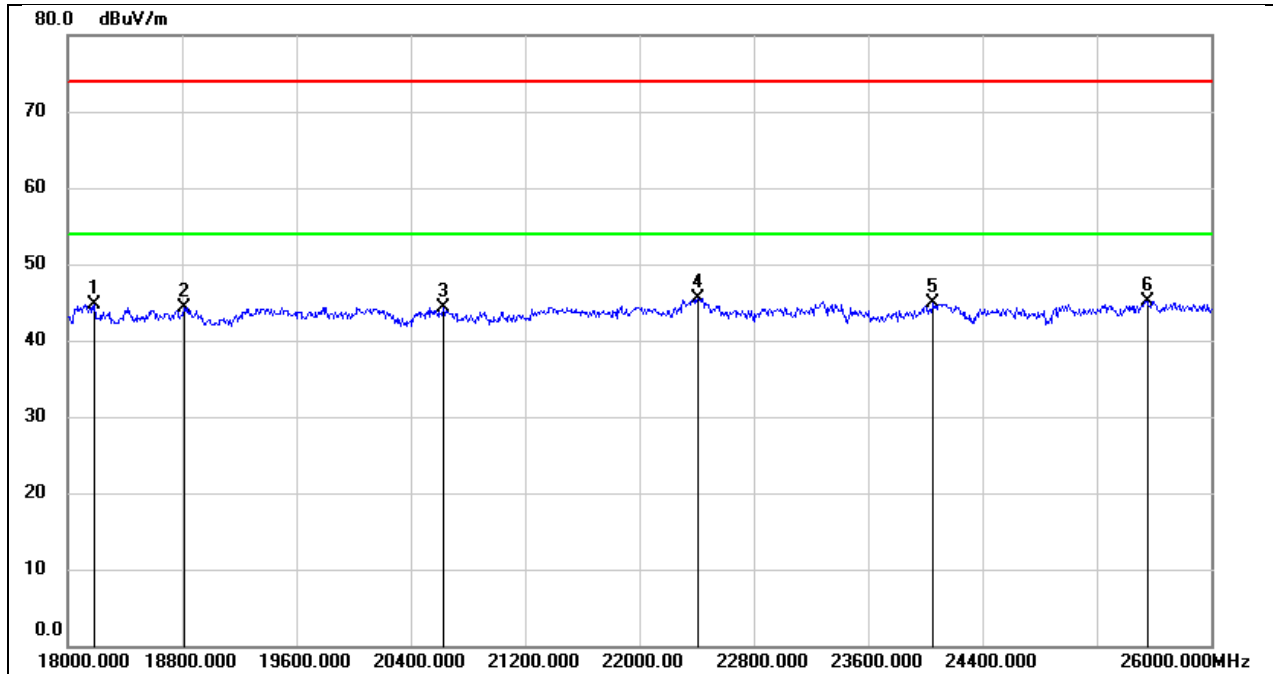

No.	Frequency (MHz)	Reading (dBuV)	Correct (dB/m)	Result (dBuV/m)	Limit (dBuV/m)	Margin (dB)	Remark
1	18184.000	50.15	-5.51	44.64	74.00	-29.36	peak
2	18816.000	49.71	-5.38	44.33	74.00	-29.67	peak
3	20632.000	49.48	-5.23	44.25	74.00	-29.75	peak
4	22408.000	49.57	-4.01	45.56	74.00	-28.44	peak
5	24056.000	47.60	-2.77	44.83	74.00	-29.17	peak
6	25552.000	46.70	-1.54	45.16	74.00	-28.84	peak

Test Mode:	802.11a 20	Frequency(MHz):	5745
Polarity:	Vertical	Test Voltage:	AC 120V_60Hz

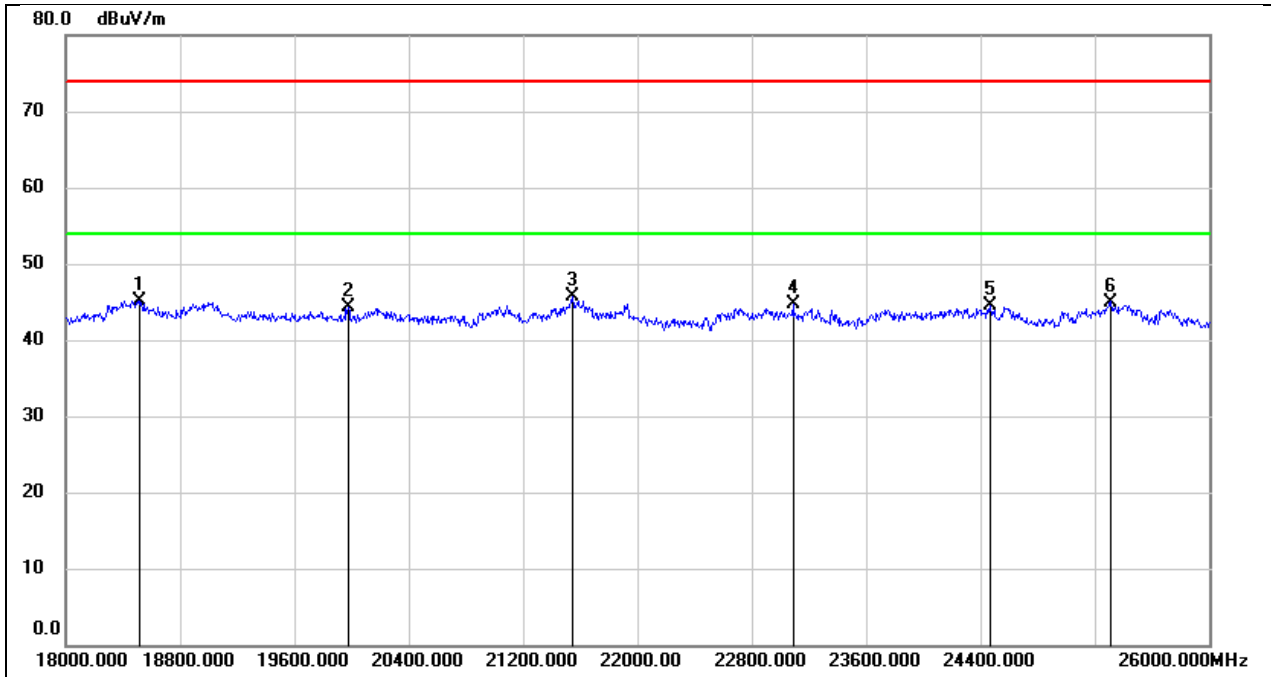

No.	Frequency (MHz)	Reading (dBuV)	Correct (dB/m)	Result (dBuV/m)	Limit (dBuV/m)	Margin (dB)	Remark
1	18520.000	50.44	-5.26	45.18	74.00	-28.82	peak
2	19976.000	49.67	-5.44	44.23	74.00	-29.77	peak
3	21544.000	50.26	-4.63	45.63	74.00	-28.37	peak
4	23088.000	48.02	-3.41	44.61	74.00	-29.39	peak
5	24472.000	46.87	-2.38	44.49	74.00	-29.51	peak
6	25312.000	46.70	-1.70	45.00	74.00	-29.00	peak

### 8.6. SPURIOUS EMISSIONS(26 GHZ~40 GHZ)

Test Mode:	802.11a 20	Frequency(MHz):	5745
Polarity:	Horizontal	Test Voltage:	AC 120V_60Hz

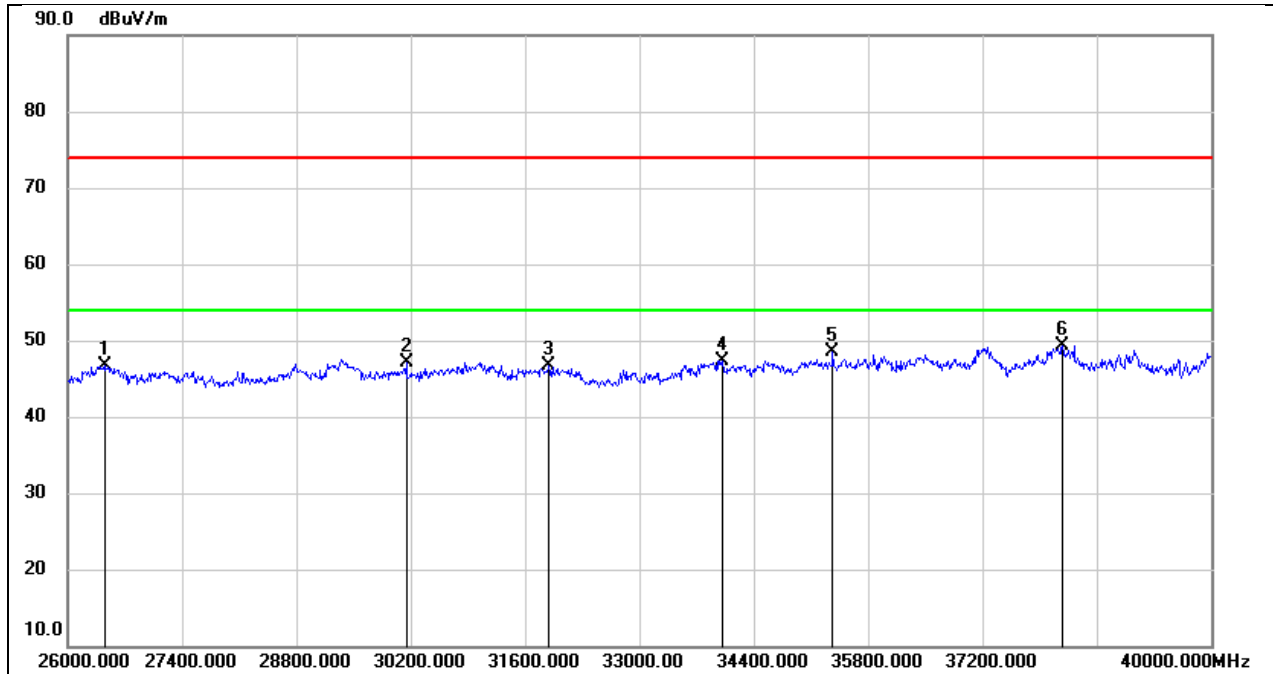

No.	Frequency (MHz)	Reading (dBuV)	Correct (dB/m)	Result (dBuV/m)	Limit (dBuV/m)	Margin (dB)	Remark
1	26448.000	51.49	-4.85	46.64	74.00	-27.36	peak
2	30144.000	48.46	-1.30	47.16	74.00	-26.84	peak
3	31894.000	48.38	-1.76	46.62	74.00	-27.38	peak
4	34008.000	46.26	1.12	47.38	74.00	-26.62	peak
5	35366.000	45.90	2.59	48.49	74.00	-25.51	peak
6	38180.000	45.64	3.69	49.33	74.00	-24.67	peak

Test Mode:	802.11a 20	Frequency(MHz):	5745
Polarity:	Vertical	Test Voltage:	AC 120V_60Hz

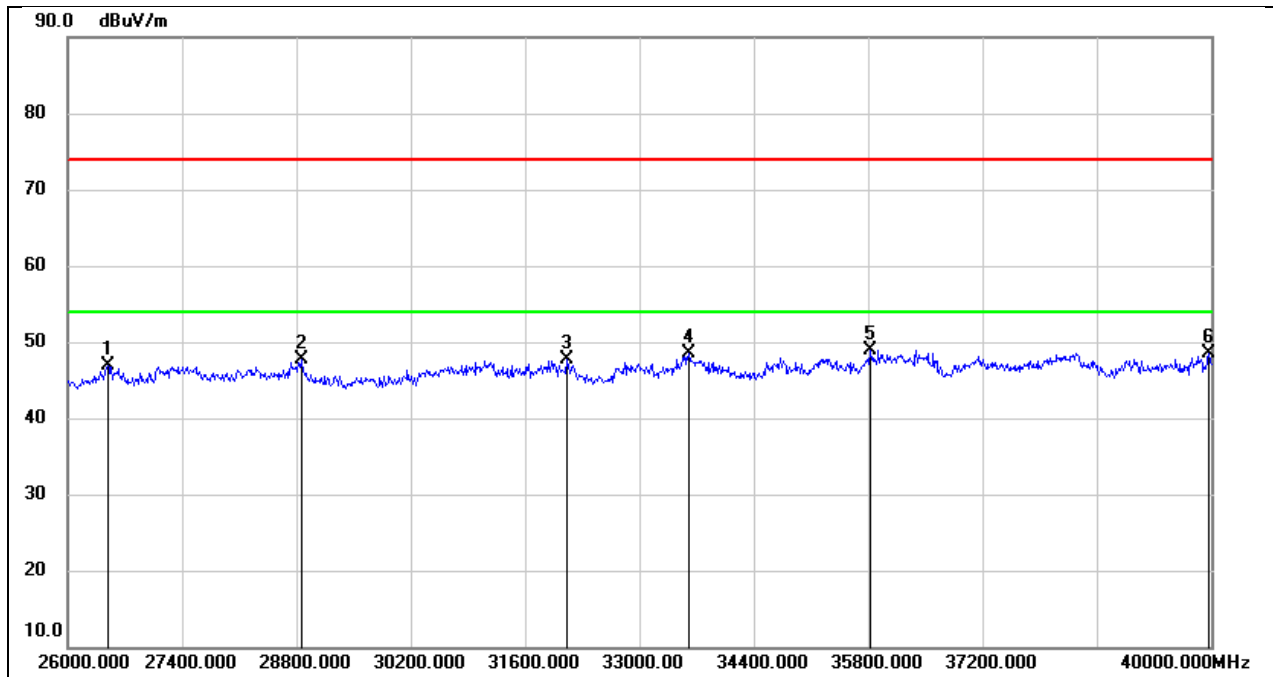

No.	Frequency (MHz)	Reading (dBuV)	Correct (dB/m)	Result (dBuV/m)	Limit (dBuV/m)	Margin (dB)	Remark
1	26490.000	51.55	-4.74	46.81	74.00	-27.19	peak
2	28856.000	48.61	-0.90	47.71	74.00	-26.29	peak
3	32104.000	49.49	-1.75	47.74	74.00	-26.26	peak
4	33602.000	48.01	0.46	48.47	74.00	-25.53	peak
5	35828.000	45.25	3.67	48.92	74.00	-25.08	peak
6	39972.000	43.45	5.13	48.58	74.00	-25.42	peak

### 8.7. SPURIOUS EMISSIONS(30 MHZ~1 GHZ)

Test Mode:	802.11a 20	Frequency(MHz):	5745
Polarity:	Horizontal	Test Voltage:	AC120V_60Hz

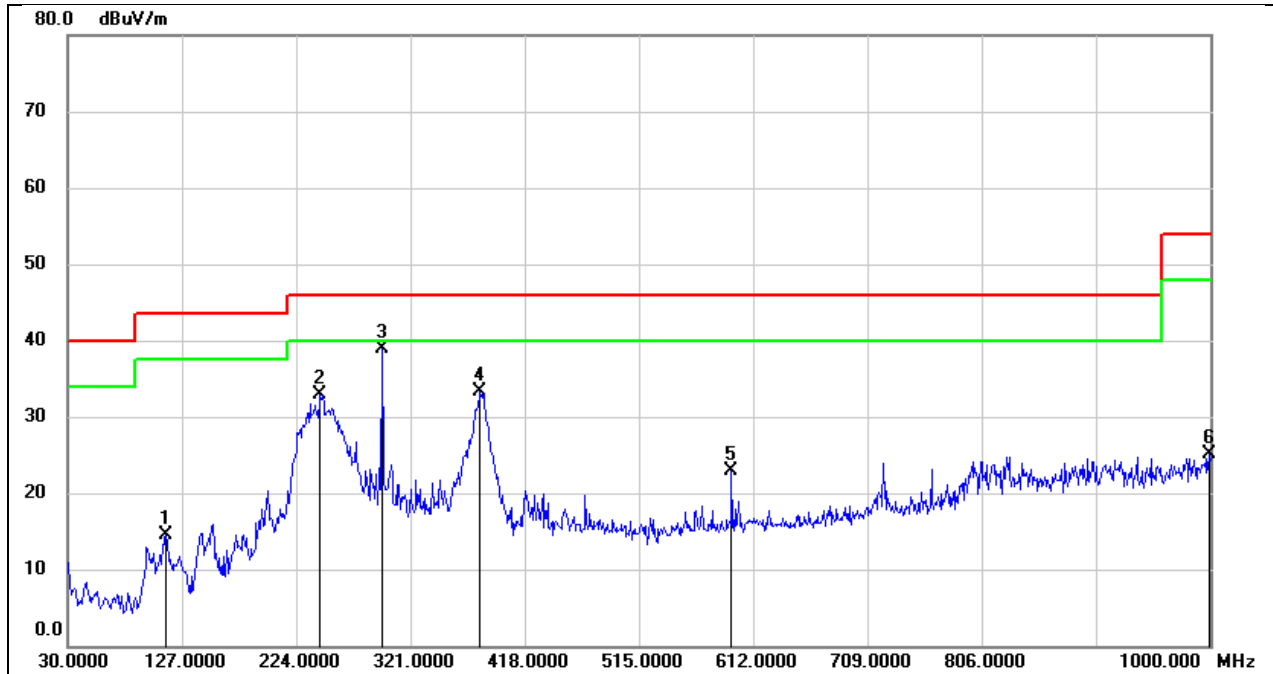

No.	Frequency (MHz)	Reading (dBuV)	Correct (dB/m)	Result (dBuV/m)	Limit (dBuV/m)	Margin (dB)	Remark
1	113.4200	30.35	-15.82	14.53	43.50	-28.97	QP
2	244.3700	48.17	-15.23	32.94	46.00	-13.06	QP
3	296.7500	51.69	-12.79	38.90	46.00	-7.10	QP
4	380.1700	44.15	-10.82	33.33	46.00	-12.67	QP
5	593.5700	30.32	-7.46	22.86	46.00	-23.14	QP
6	999.0300	27.23	-2.12	25.11	54.00	-28.89	QP

Test Mode:	802.11a 20	Frequency(MHz):	5745
Polarity:	Vertical	Test Voltage:	AC120V_60Hz

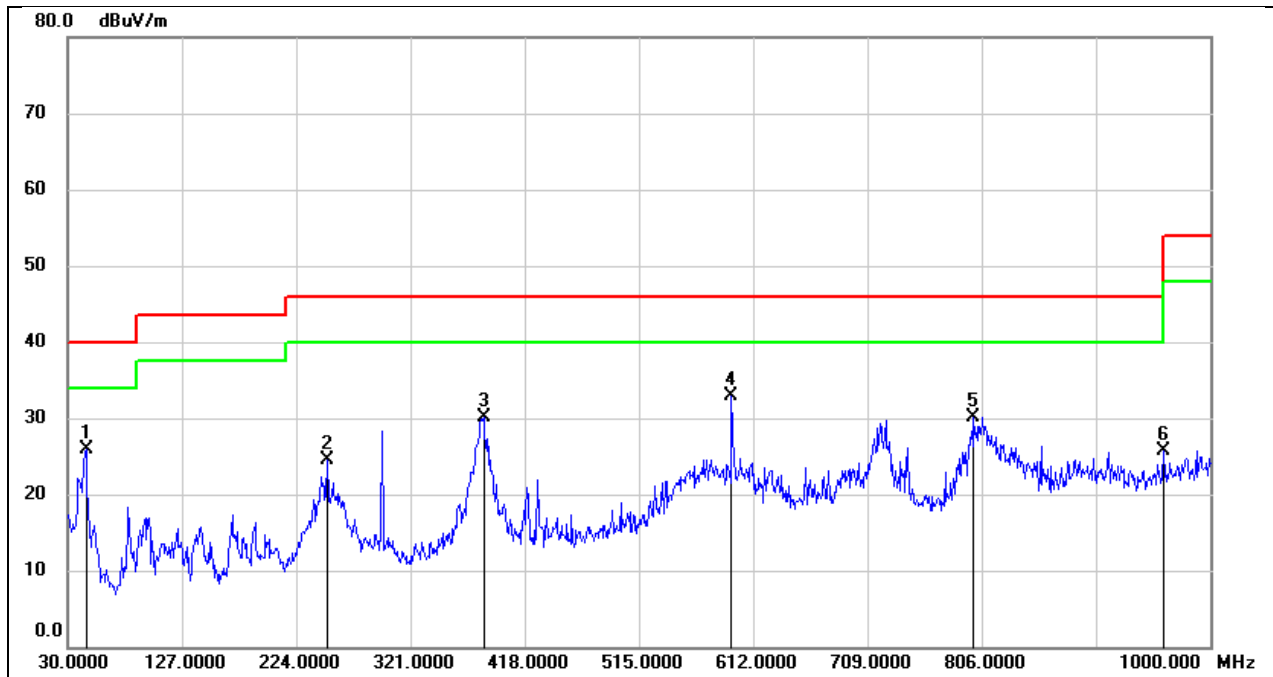

No.	Frequency (MHz)	Reading (dBuV)	Correct (dB/m)	Result (dBuV/m)	Limit (dBuV/m)	Margin (dB)	Remark
1	45.5200	41.31	-15.32	25.99	40.00	-14.01	QP
2	250.1900	39.95	-15.53	24.42	46.00	-21.58	QP
3	383.0799	40.86	-10.83	30.03	46.00	-15.97	QP
4	593.5700	40.35	-7.46	32.89	46.00	-13.11	QP
5	799.2100	34.48	-4.41	30.07	46.00	-15.93	QP
6	960.2300	28.32	-2.62	25.70	54.00	-28.30	QP



## 9. AC POWER LINE CONDUCTED EMISSION

### LIMITS

Please refer to CFR 47 FCC §15.207 (a).

FREQUENCY (MHz)	Quasi-peak	Average
0.15 -0.5	66 - 56 *	56 - 46 *
0.50 -5.0	56.00	46.00
5.0 -30.0	60.00	50.00

### TEST PROCEDURE

Refer to ANSI C63.10-2013 clause 6.2.

The EUT is put on a table of non-conducting material that is 80 cm high. The vertical conducting wall of shielding is located 40 cm to the rear of the EUT. The power line of the EUT is connected to the AC mains through a Artificial Mains Network (A.M.N.). A EMI Measurement Receiver (R&S Test Receiver ESR3) is used to test the emissions from both sides of AC line. According to the requirements in Section 6.2 of ANSI C63.10-2013. Conducted emissions from the EUT measured in the frequency range between 0.15 MHz and 30 MHz using CISPR Quasi-Peak and average detector mode. The bandwidth of EMI test receiver is set at 9 kHz.

The arrangement of the equipment is installed to meet the standards and operating in a manner, which tends to maximize its emission characteristics in a normal application.

### TEST SETUP

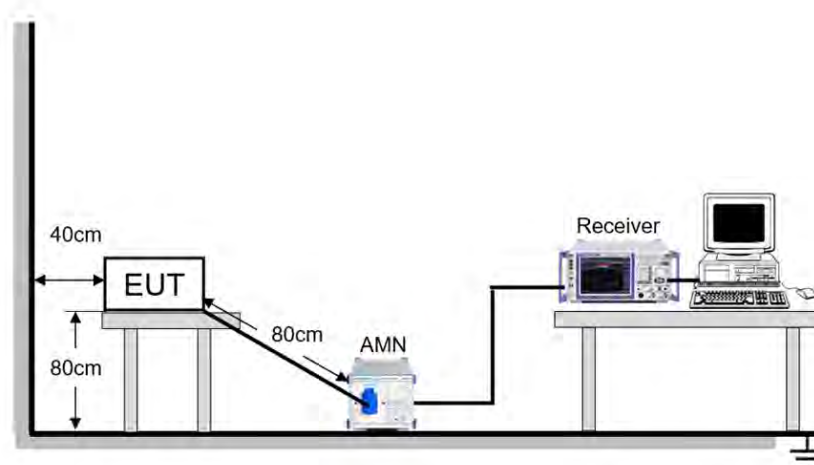

**TEST ENVIRONMENT**

Temperature	21.6°C	Relative Humidity	55.3%
Atmosphere Pressure	101kPa	Test Voltage	AC 120V 60Hz

**TEST DATE / ENGINEER**

Test Date	June 26, 2025	Test By	Deacon Tan
-----------	---------------	---------	------------

**TEST RESULTS**

Test Mode:	802.11a	Frequency(MHz):	5745
Line:	Line		

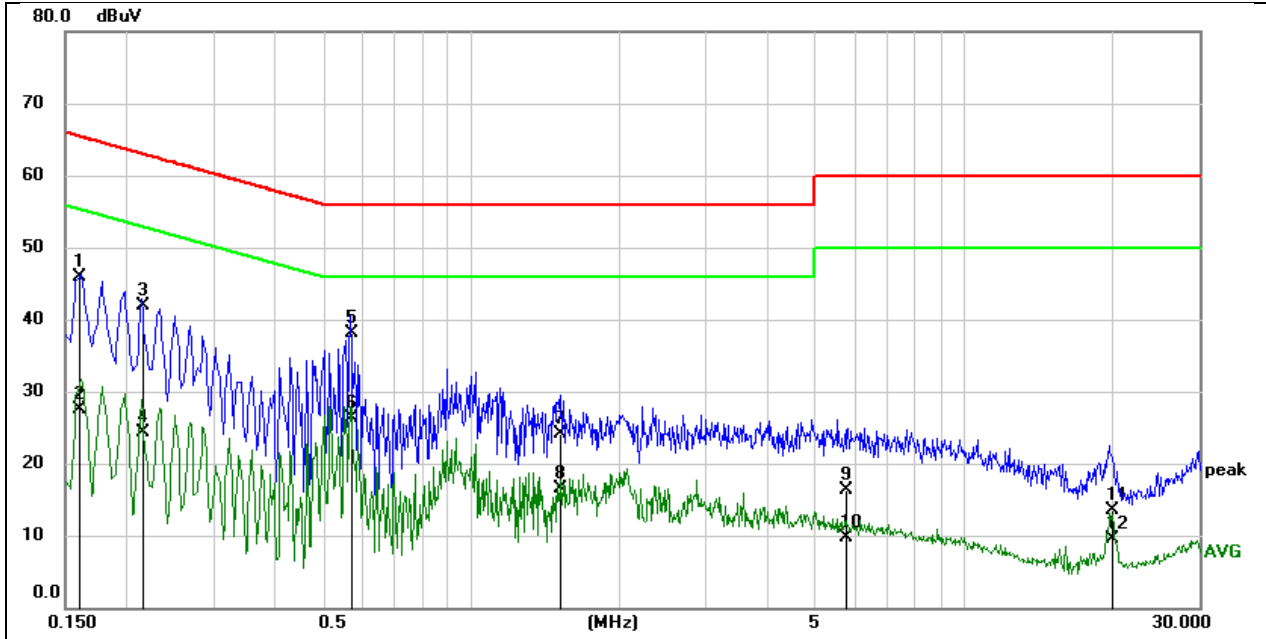

No.	Frequency (MHz)	Reading (dBuV)	Correct (dB)	Result (dBuV)	Limit (dBuV)	Margin (dB)	Remark
1	0.1606	36.09	9.72	45.81	65.43	-19.62	QP
2	0.1606	17.73	9.72	27.45	55.43	-27.98	AVG
3	0.2157	32.19	9.64	41.83	62.98	-21.15	QP
4	0.2157	14.67	9.64	24.31	52.98	-28.67	AVG
5	0.5718	28.53	9.64	38.17	56.00	-17.83	QP
6	0.5718	16.76	9.64	26.40	46.00	-19.60	AVG
7	1.5215	14.40	9.69	24.09	56.00	-31.91	QP
8	1.5215	6.78	9.69	16.47	46.00	-29.53	AVG
9	5.7467	6.62	9.73	16.35	60.00	-43.65	QP
10	5.7467	0.05	9.73	9.78	50.00	-40.22	AVG
11	20.0852	3.79	9.74	13.53	60.00	-46.47	QP
12	20.0852	-0.29	9.74	9.45	50.00	-40.55	AVG

Note:

1. Result = Reading + Correct Factor.
2. If QP Result complies with AV limit, AV Result is deemed to comply with AV limit.
3. Test setup: RBW: 200 Hz (9 kHz ~ 150 kHz), 9 kHz (150 kHz ~ 30 MHz).
4. Step size: 80 Hz (0.009 MHz ~ 0.15 MHz), 4 kHz (0.15 MHz ~ 30 MHz), Scan time: auto.

Note: All the modes have been tested, only the worst data was recorded in the report.

Test Mode:	802.11a	Frequency(MHz):	5745
Line:	Neutral		

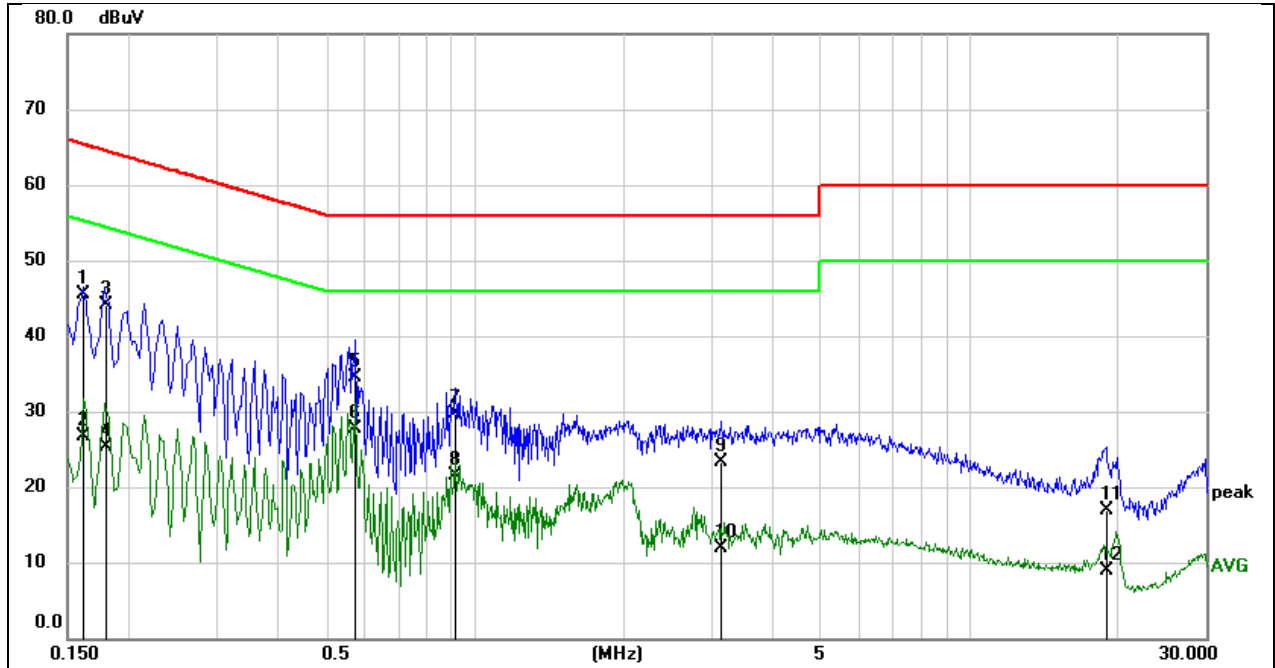

No.	Frequency (MHz)	Reading (dBuV)	Correct (dB)	Result (dBuV)	Limit (dBuV)	Margin (dB)	Remark
1	0.1616	35.84	9.64	45.48	65.38	-19.90	QP
2	0.1616	17.08	9.64	26.72	55.38	-28.66	AVG
3	0.1799	34.42	9.64	44.06	64.49	-20.43	QP
4	0.1799	15.75	9.64	25.39	54.49	-29.10	AVG
5	0.5747	24.90	9.64	34.54	56.00	-21.46	QP
6	0.5747	18.06	9.64	27.70	46.00	-18.30	AVG
7	0.9130	20.10	9.63	29.73	56.00	-26.27	QP
8	0.9130	11.88	9.63	21.51	46.00	-24.49	AVG
9	3.1510	13.68	9.63	23.31	56.00	-32.69	QP
10	3.1510	2.31	9.63	11.94	46.00	-34.06	AVG
11	18.8485	7.20	9.74	16.94	60.00	-43.06	QP
12	18.8485	-0.93	9.74	8.81	50.00	-41.19	AVG

**Note:**

1. Result = Reading + Correct Factor.
2. If QP Result complies with AV limit, AV Result is deemed to comply with AV limit.
3. Test setup: RBW: 200 Hz (9 kHz ~ 150 kHz), 9 kHz (150 kHz ~ 30 MHz).
4. Step size: 80 Hz (0.009 MHz ~ 0.15 MHz), 4 kHz (0.15 MHz ~ 30 MHz), Scan time: auto.

Note: All the modes have been tested, only the worst data was recorded in the report.

## 10. ANTENNA REQUIREMENT

### REQUIREMENT

Please refer to FCC part 15.203

An intentional radiator shall be designed to ensure that no antenna other than that furnished by the responsible party shall be used with the device. The use of a permanently attached antenna or of an antenna that uses a unique coupling to the intentional radiator shall be considered sufficient to comply with the provisions of this section. The manufacturer may design the unit so that a broken antenna can be replaced by the user, but the use of a standard antenna jack or electrical connector is prohibited.

Please refer to FCC part 15.407(a)

For an indoor access point operating in the band 5.15-5.25 GHz, the maximum conducted output power over the frequency band of operation shall not exceed 1 W provided the maximum antenna gain does not exceed 6 dBi. In addition, the maximum power spectral density shall not exceed 17 dBm in any 1 megahertz band. If transmitting antennas of directional gain greater than 6 dBi are used, both the maximum conducted output power and the maximum power spectral density shall be reduced by the amount in dB that the directional gain of the antenna exceeds 6 dBi.

### DESCRIPTION

Pass

## 11. TEST DATA

### 11.1. APPENDIX A: EMISSION BANDWIDTH

#### 11.1.1. Test Result

Test Mode	Antenna	Frequency[MHz]	26db EBW [MHz]	FL[MHz]	FH[MHz]	Verdict
11A	Ant1	5180	23.16	5169.64	5192.80	PASS
		5200	18.20	5191.24	5209.44	PASS
		5240	21.60	5230.04	5251.64	PASS
		5260	17.88	5251.40	5269.28	PASS
		5280	20.12	5269.68	5289.80	PASS
		5320	18.04	5311.40	5329.44	PASS
		5500	18.40	5491.04	5509.44	PASS
		5580	19.16	5570.36	5589.52	PASS
		5700	19.12	5690.56	5709.68	PASS
		5720	20.44	5709.00	5729.44	PASS
		5720_UNII-2C	16	5709.00	5725	PASS
		5720_UNII-3	4.44	5725	5729.44	PASS
		5745	18.88	5735.52	5754.40	PASS
		5785	18.96	5775.48	5794.44	PASS
5825	18.76	5815.40	5834.16	PASS		
11N20SISO	Ant1	5180	18.44	5171.08	5189.52	PASS
		5200	20.20	5190.20	5210.40	PASS
		5240	21.44	5229.20	5250.64	PASS
		5260	18.00	5251.48	5269.48	PASS
		5280	21.12	5270.40	5291.52	PASS
		5320	17.88	5311.64	5329.52	PASS
		5500	18.32	5491.12	5509.44	PASS
		5580	19.32	5570.32	5589.64	PASS
		5700	19.20	5690.32	5709.52	PASS
		5720	19.24	5710.32	5729.56	PASS
		5720_UNII-2C	14.68	5710.32	5725	PASS
		5720_UNII-3	4.56	5725	5729.56	PASS
		5745	19.72	5735.04	5754.76	PASS
		5785	19.56	5775.04	5794.60	PASS
5825	19.44	5815.20	5834.64	PASS		

### 11.1.2. Test Graphs

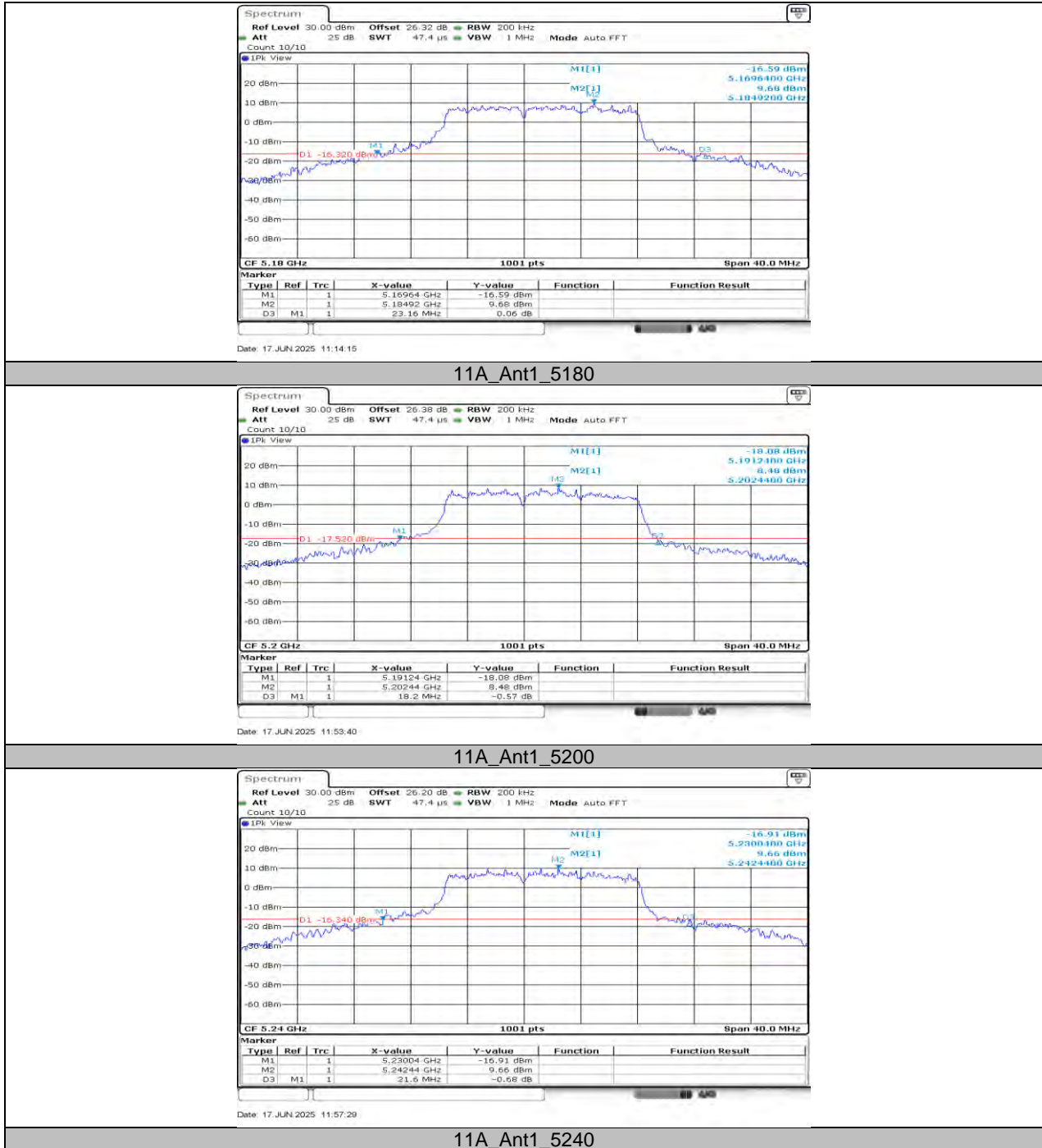

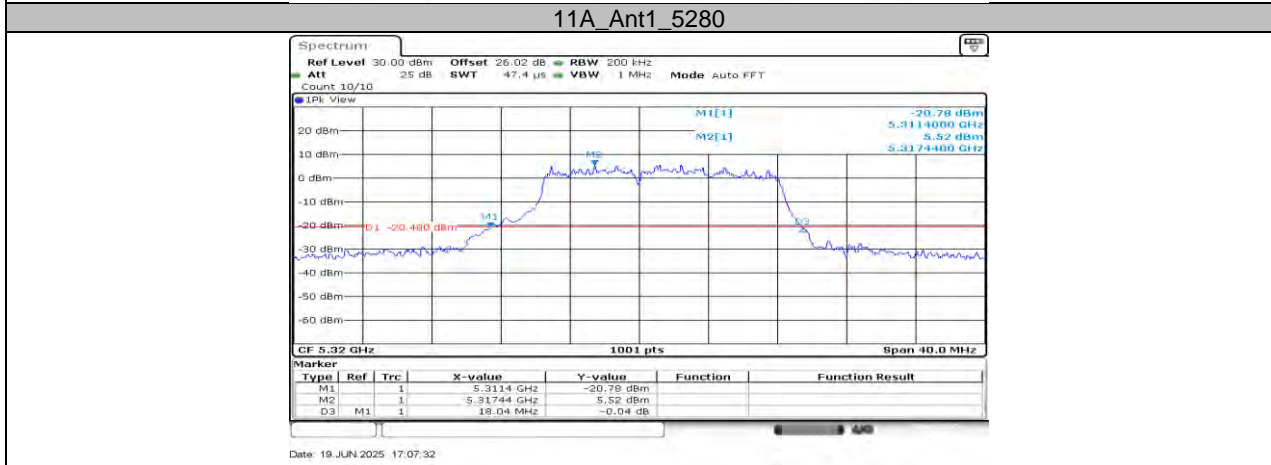
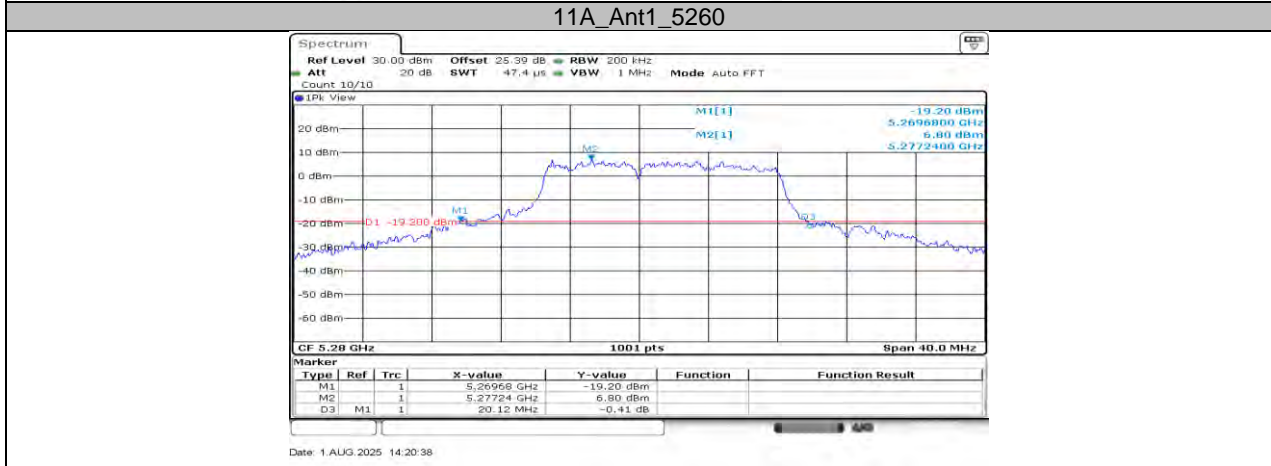
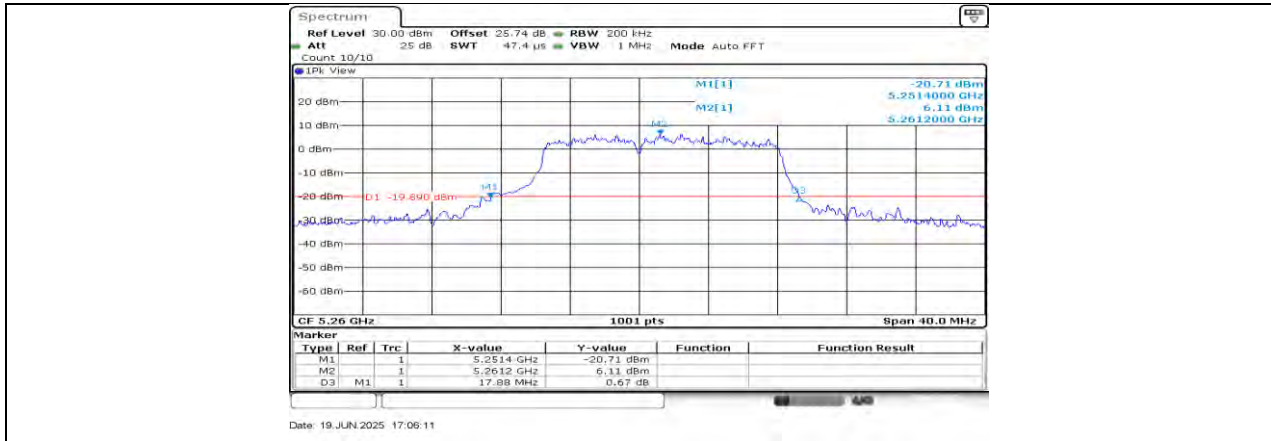



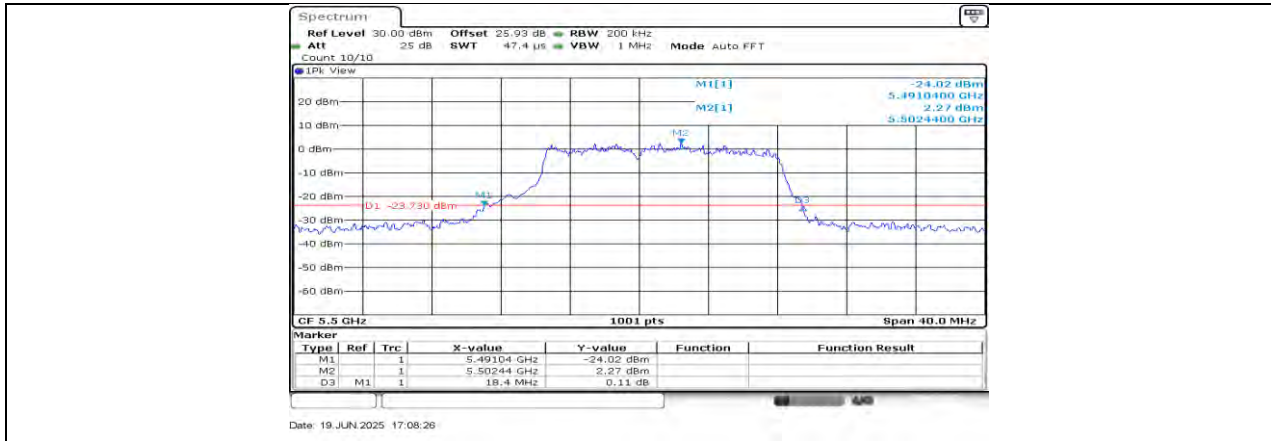

11A\_Ant1\_5500

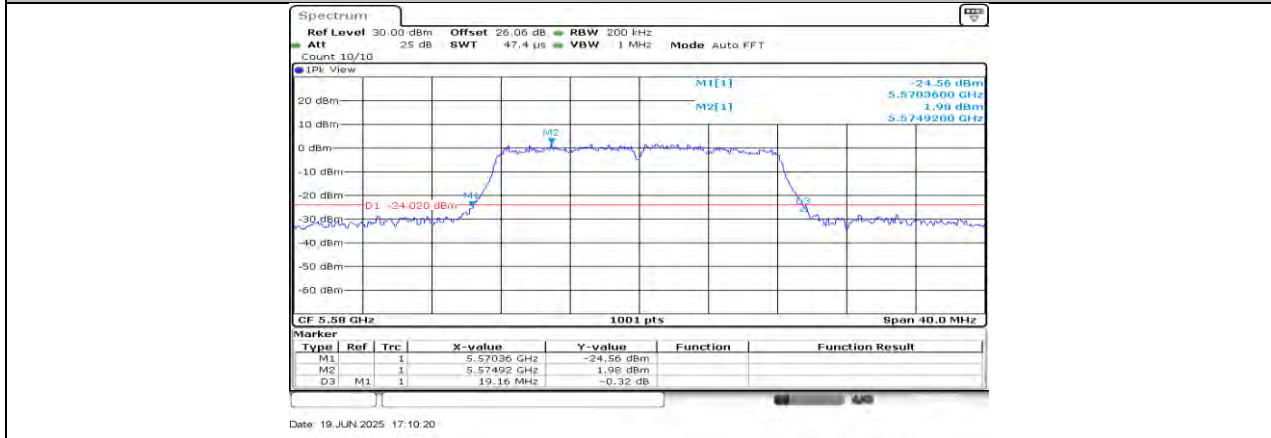

11A\_Ant1\_5580

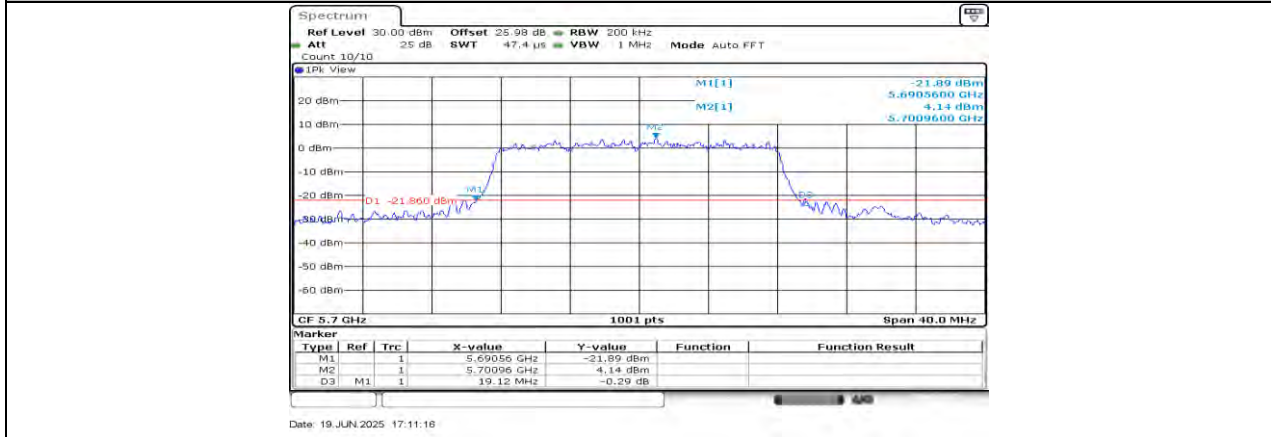

11A\_Ant1\_5700

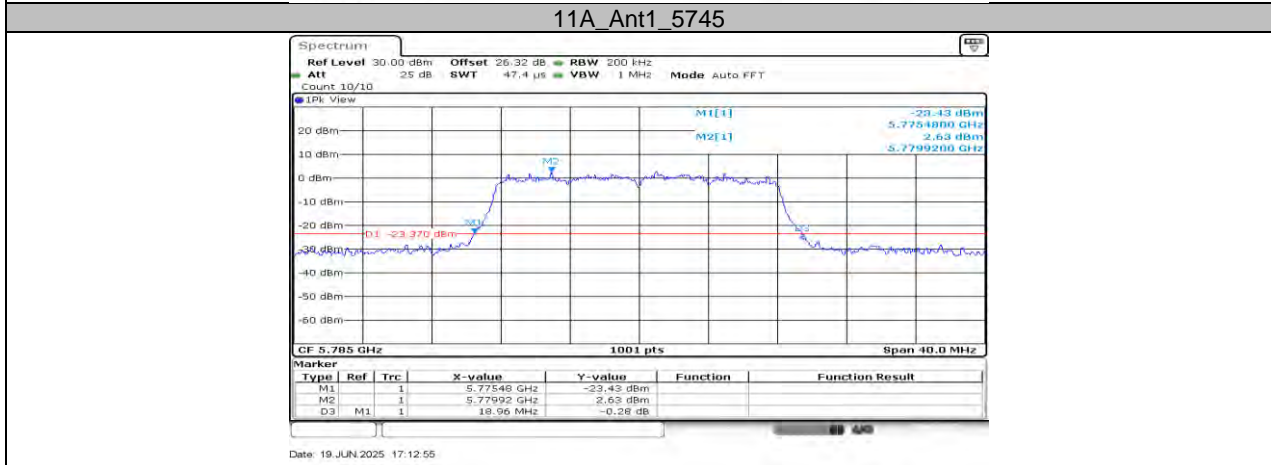
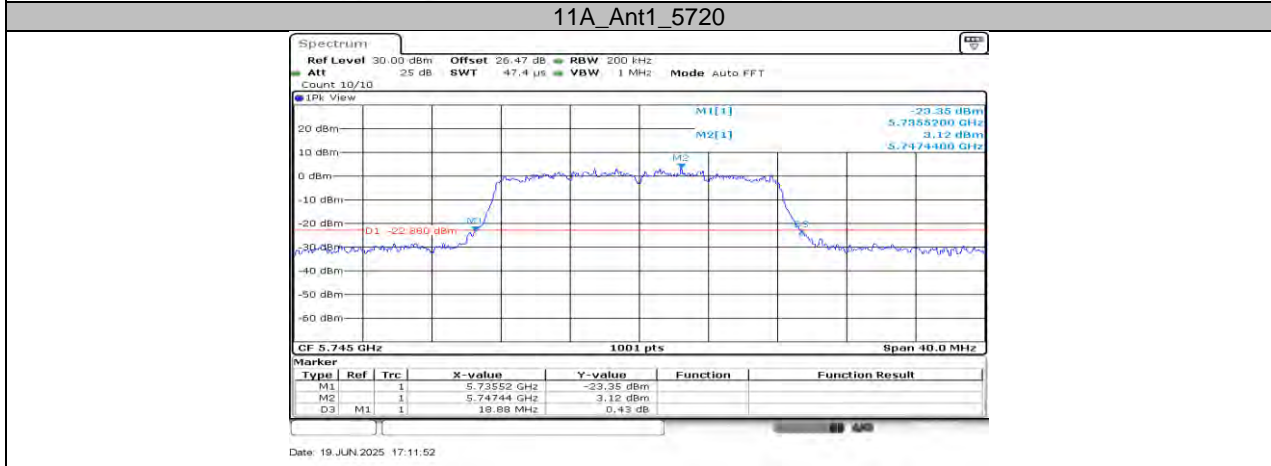
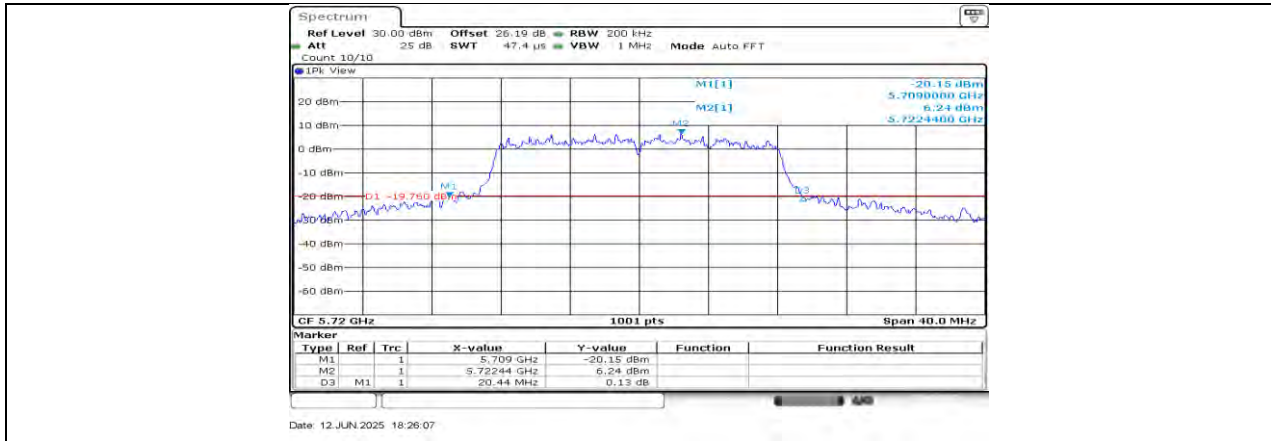

**11A\_Ant1\_5785**

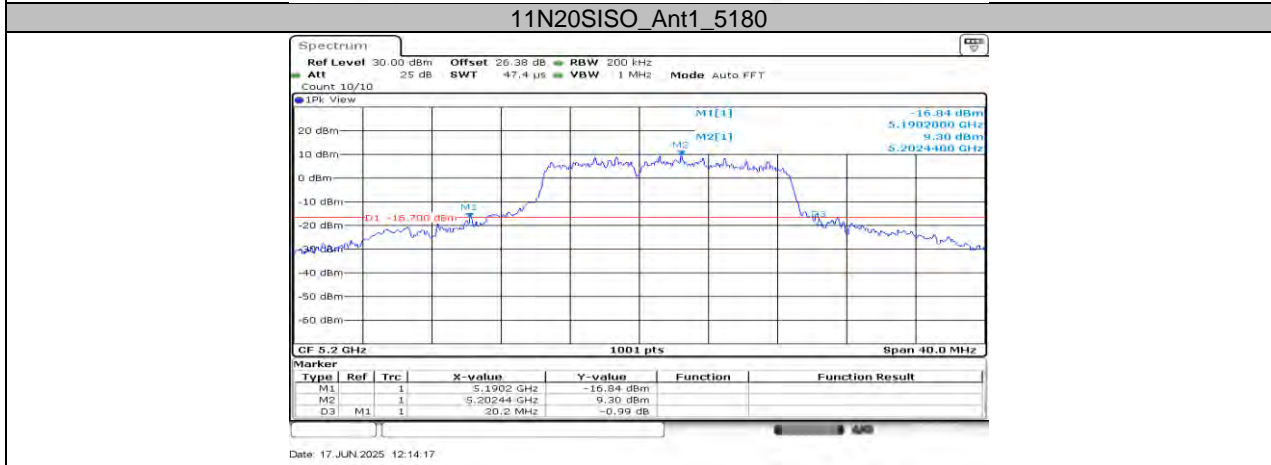
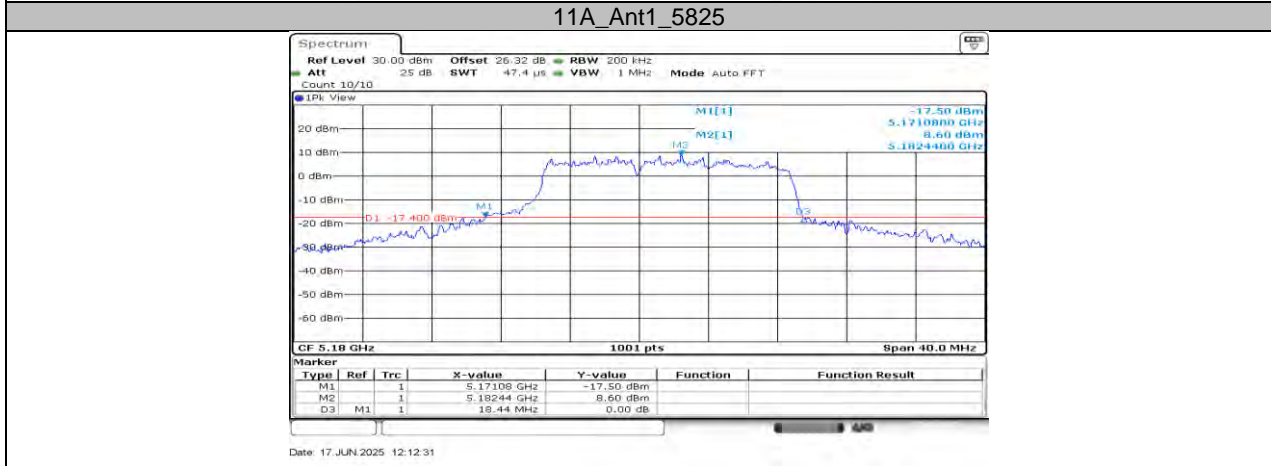
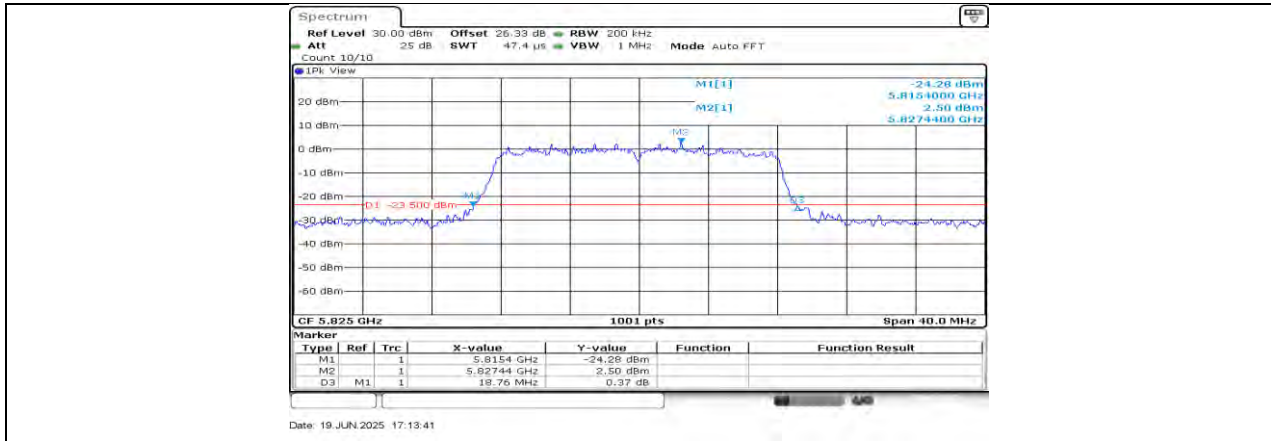

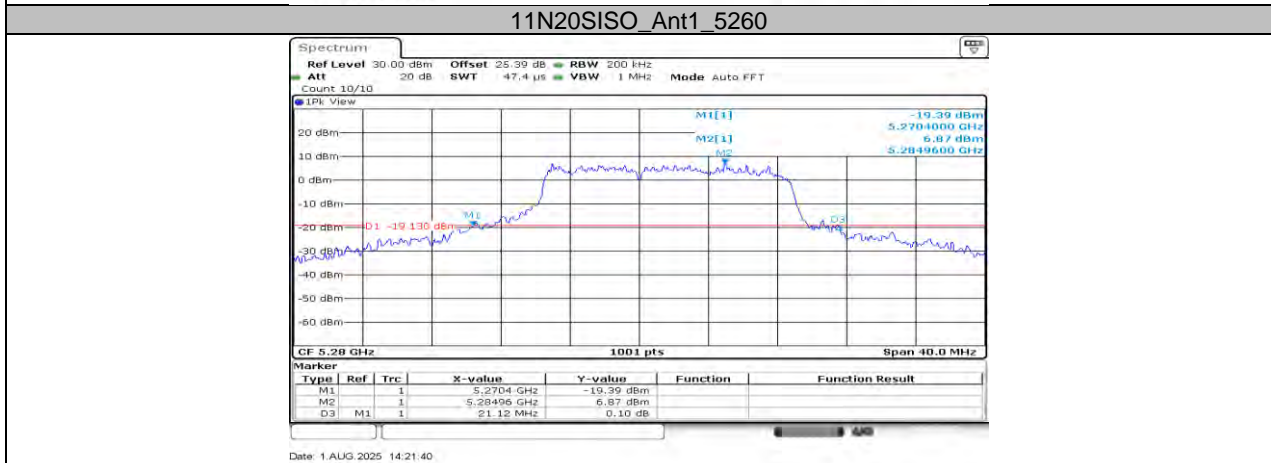
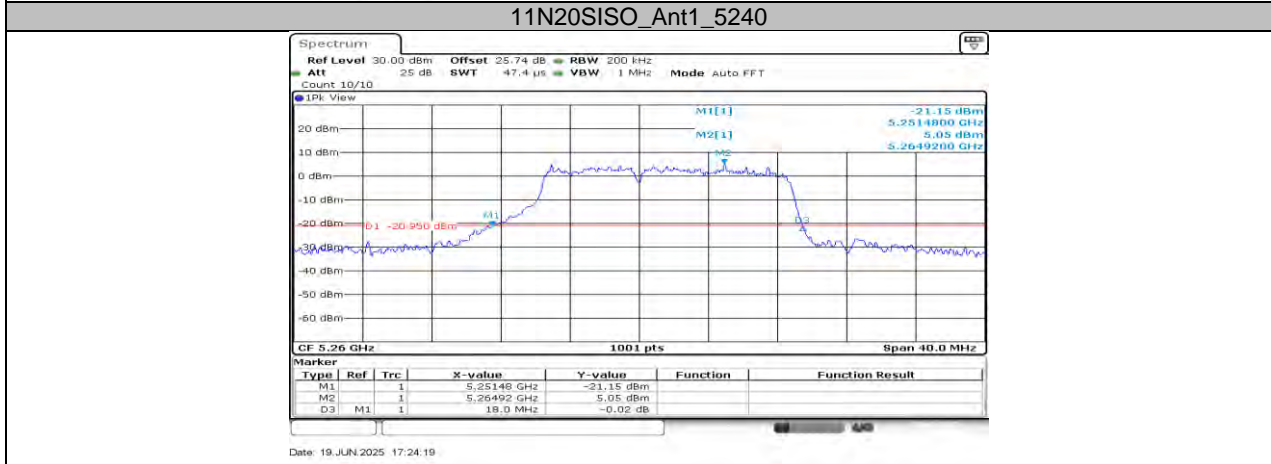
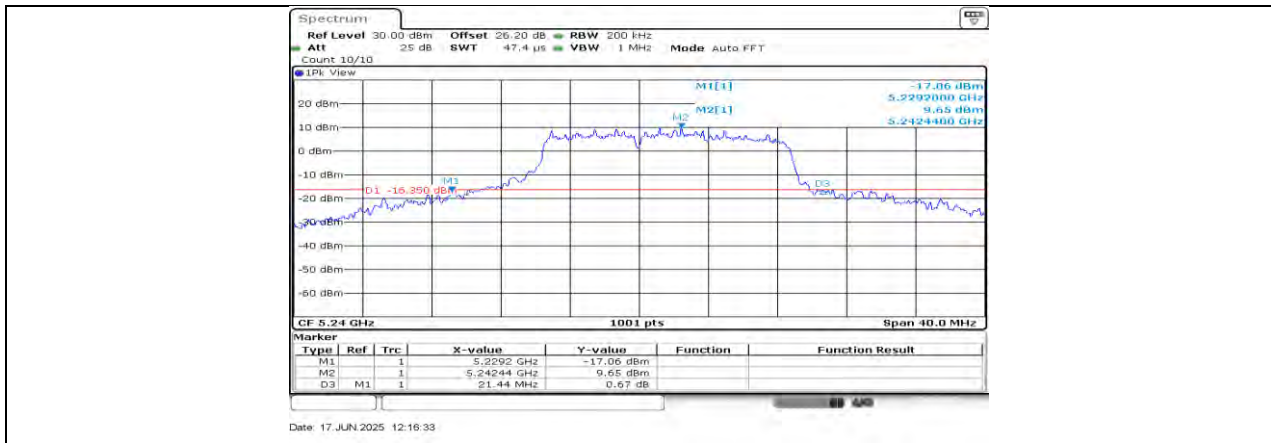



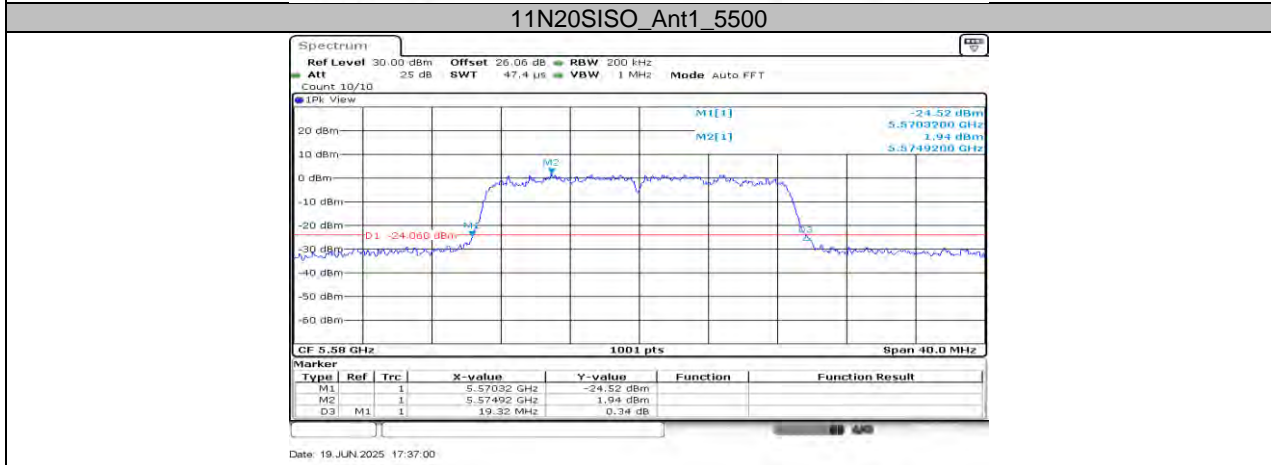
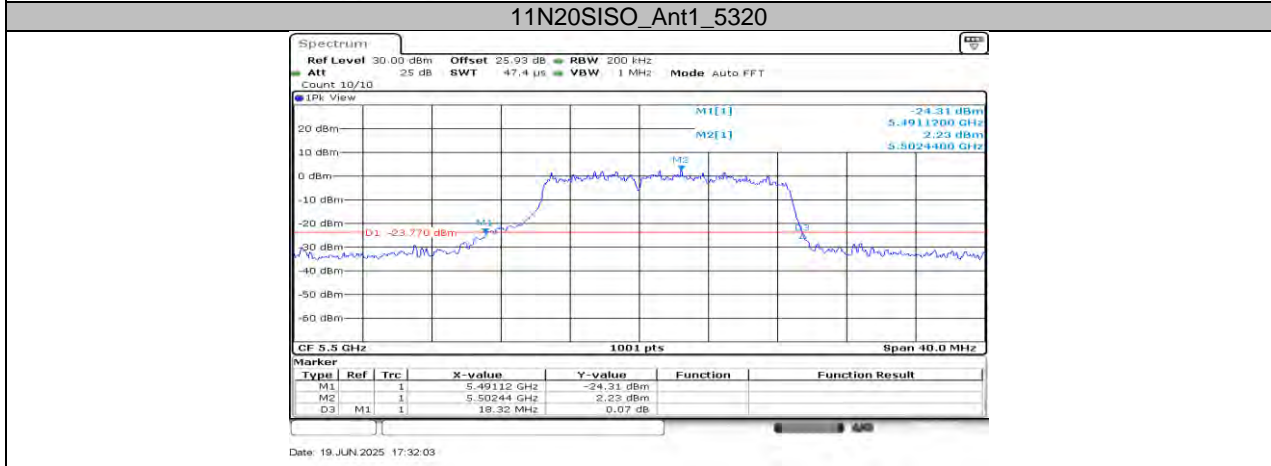
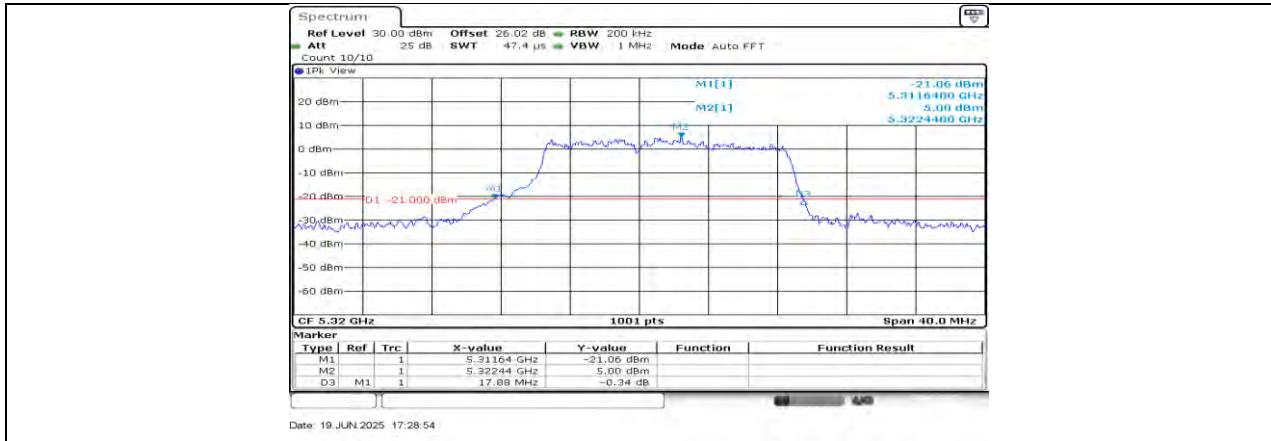

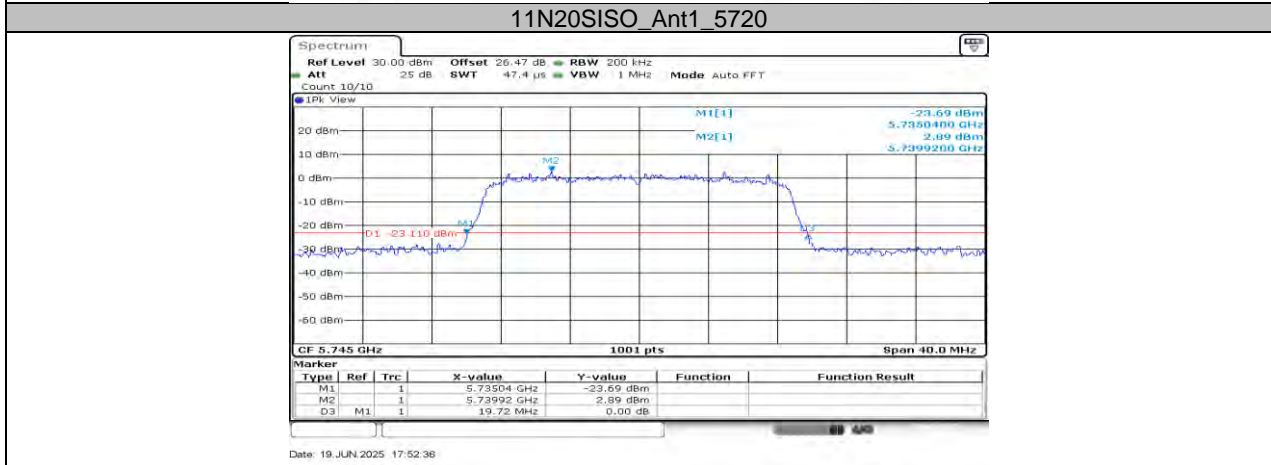
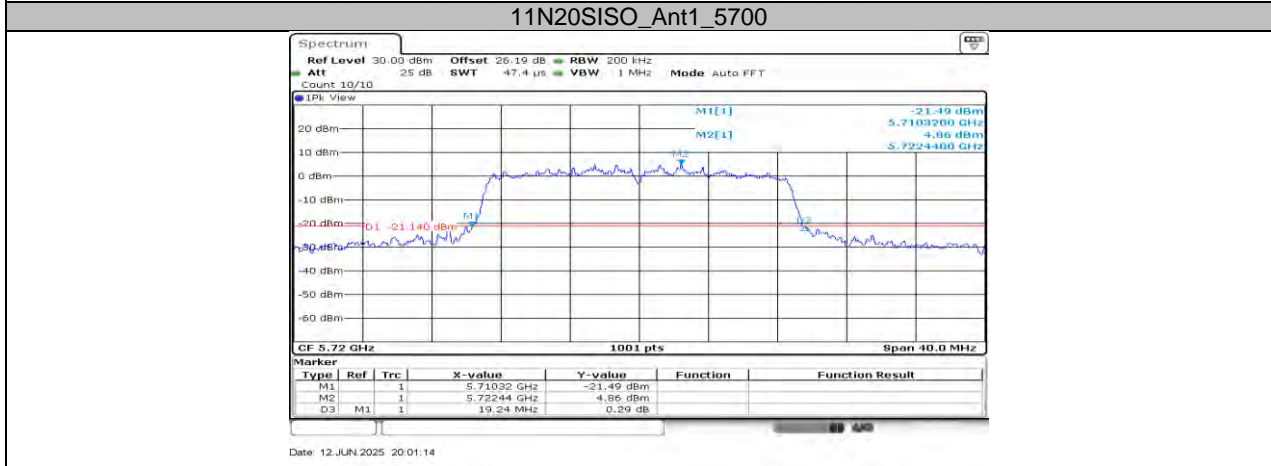
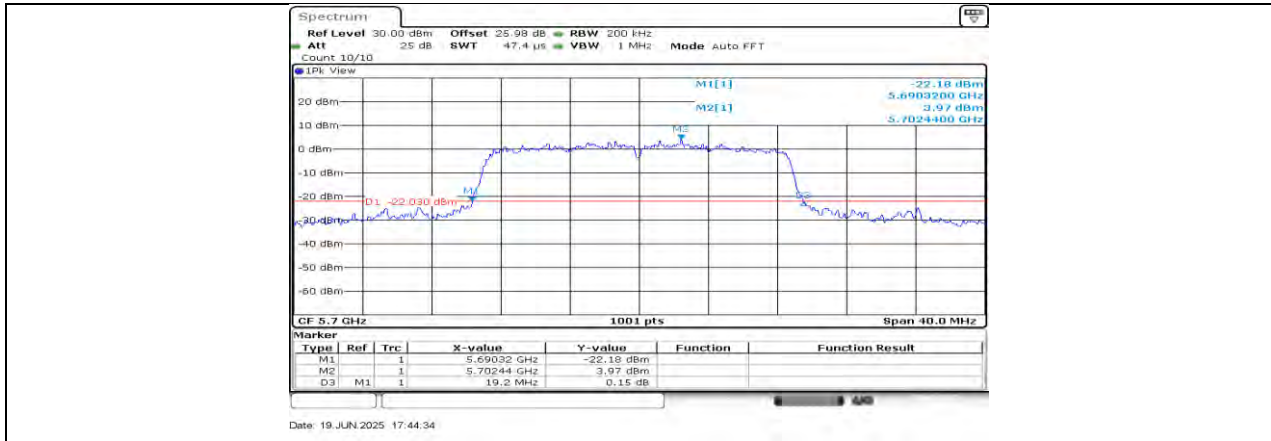

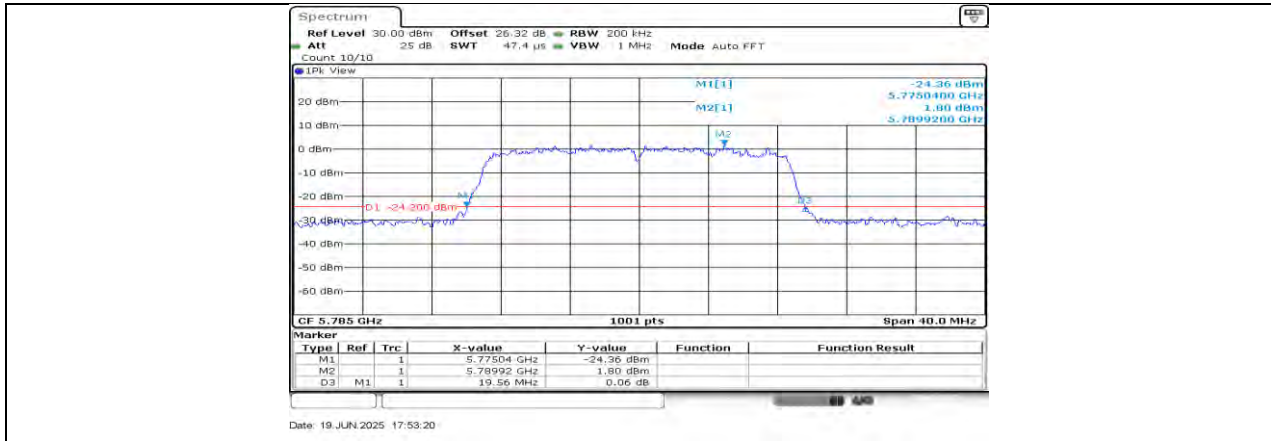

11N20SISO\_Ant1\_5785

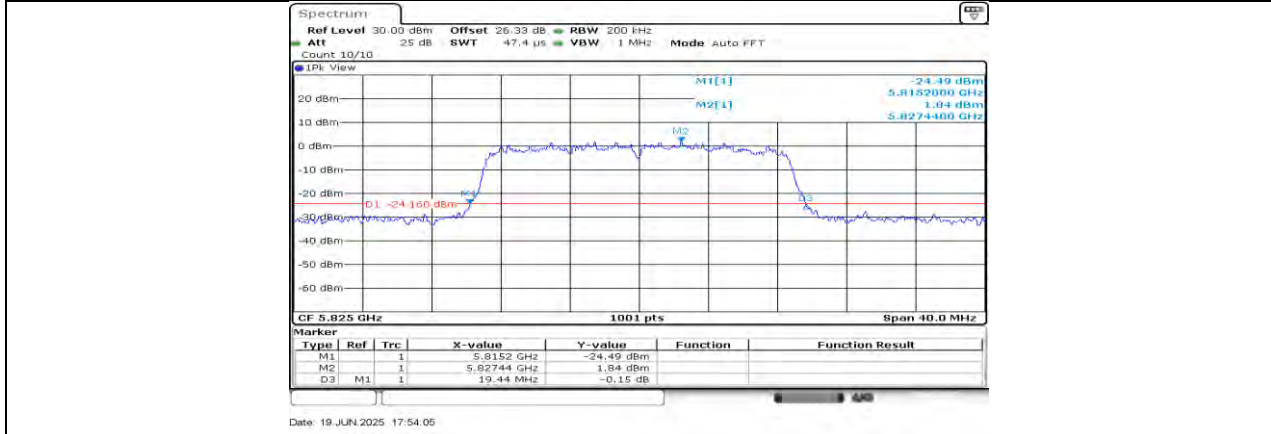

11N20SISO\_Ant1\_5825

## 11.2. APPENDIX B: OCCUPIED CHANNEL BANDWIDTH

### 11.2.1. Test Result

Test Mode	Antenna	Frequency[MHz]	OCB [MHz]	FL[MHz]	FH[MHz]	Verdict
11A	Ant1	5180	15.385	5173.4466	5188.8312	PASS
		5200	14.785	5193.7263	5208.5115	PASS
		5240	15.784	5233.0070	5248.7912	PASS
		5260	15.145	5253.3267	5268.4715	PASS
		5280	15.105	5273.4865	5288.5914	PASS
		5320	14.665	5313.7662	5328.4316	PASS
		5500	14.945	5493.4865	5508.4316	PASS
		5580	16.863	5571.5684	5588.4316	PASS
		5700	16.943	5691.4486	5708.3916	PASS
		5720	17.223	5711.2887	5728.5115	PASS
		5720_UNII-2C	13.711	5711.2887	5725	PASS
		5720_UNII-3	3.511	5725	5728.5115	PASS
		5745	16.783	5736.5684	5753.3516	PASS
		5785	16.943	5776.4486	5793.3916	PASS
		5825	16.943	5816.4486	5833.3916	PASS
11N20SISO	Ant1	5180	15.385	5173.5664	5188.9510	PASS
		5200	15.744	5193.2068	5208.9510	PASS
		5240	16.503	5232.6474	5249.1508	PASS
		5260	15.145	5253.6464	5268.7912	PASS
		5280	15.504	5273.4066	5288.9111	PASS
		5320	15.105	5313.7263	5328.8312	PASS
		5500	15.185	5493.6064	5508.7912	PASS
		5580	17.662	5571.1289	5588.7912	PASS
		5700	17.822	5691.0490	5708.8711	PASS
		5720	17.822	5711.0490	5728.8711	PASS
		5720_UNII-2C	13.951	5711.0490	5725	PASS
		5720_UNII-3	3.871	5725	5728.8711	PASS
		5745	17.702	5736.0889	5753.7912	PASS
		5785	17.702	5776.0490	5793.7512	PASS
		5825	17.742	5816.0490	5833.7912	PASS



### 11.2.2. Test Graphs

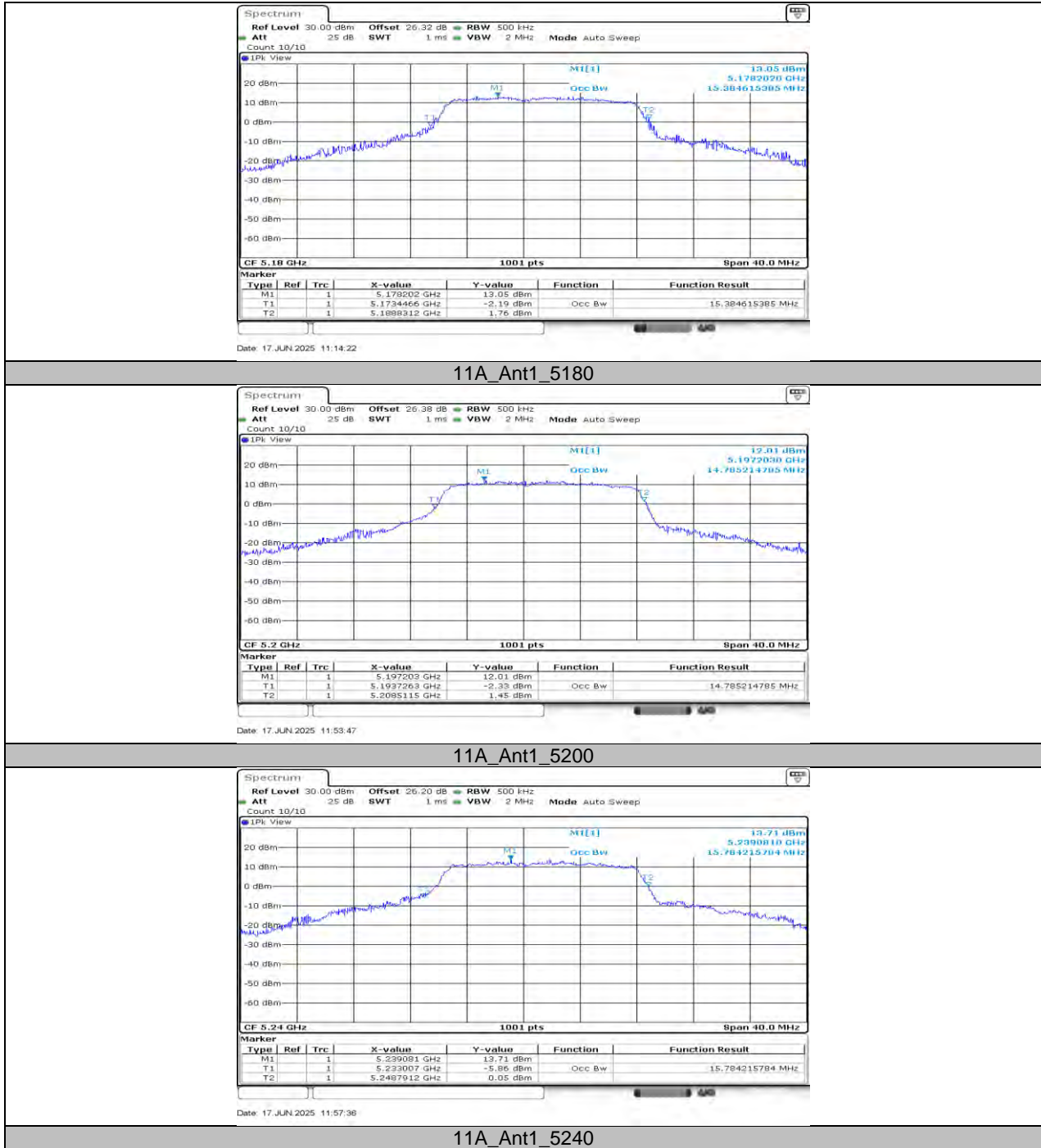

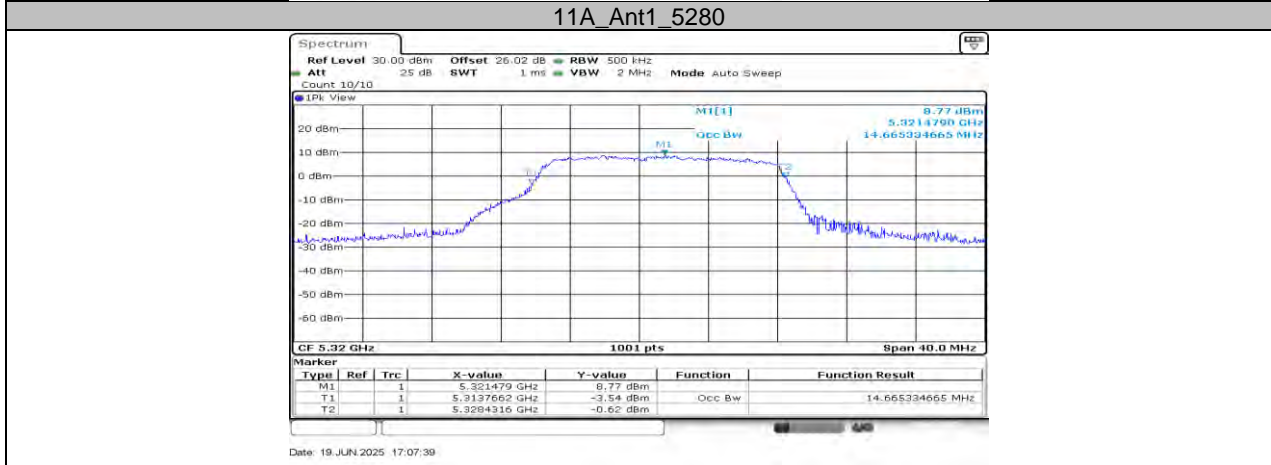

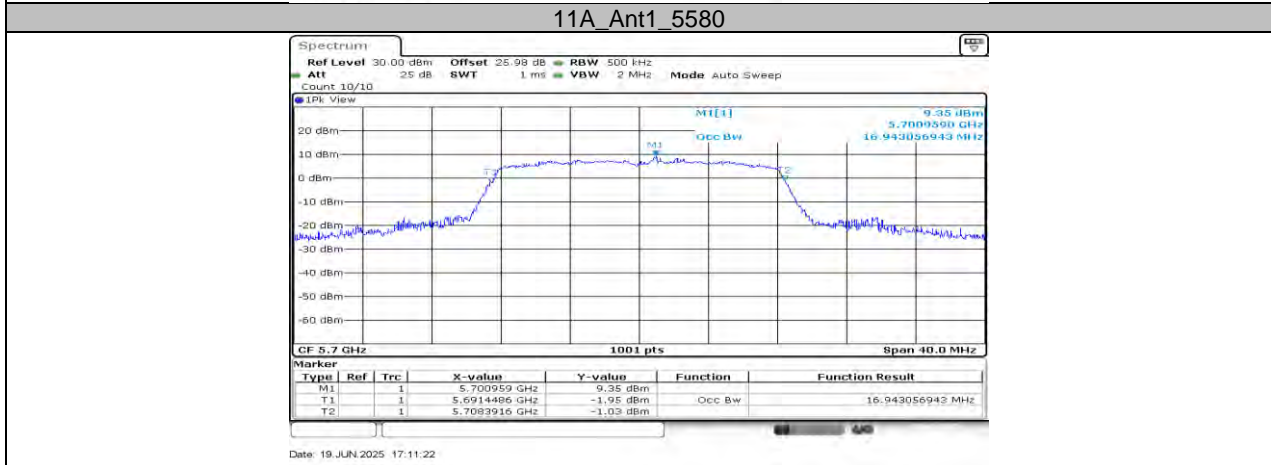
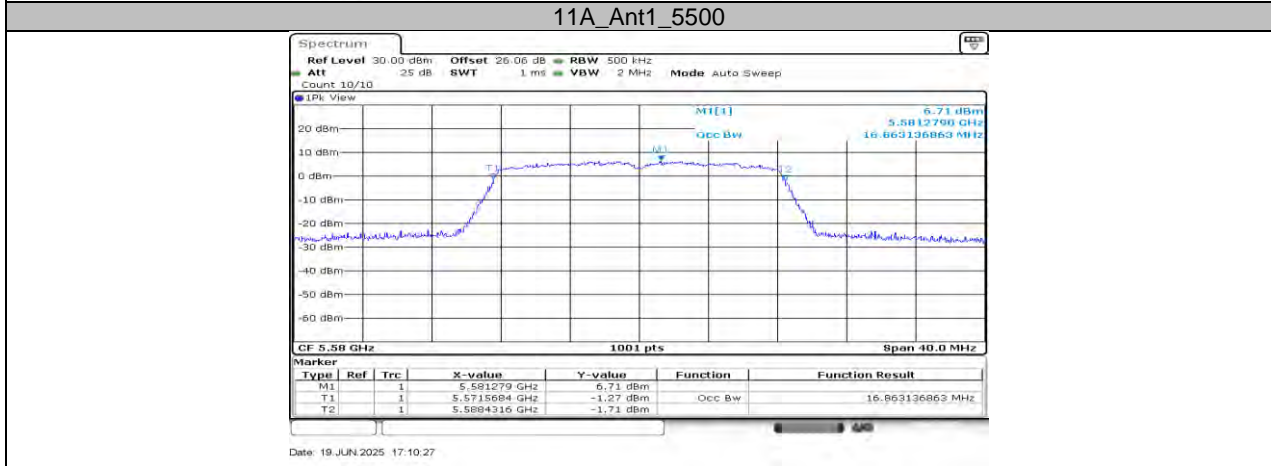

**11A\_Ant1\_5700**

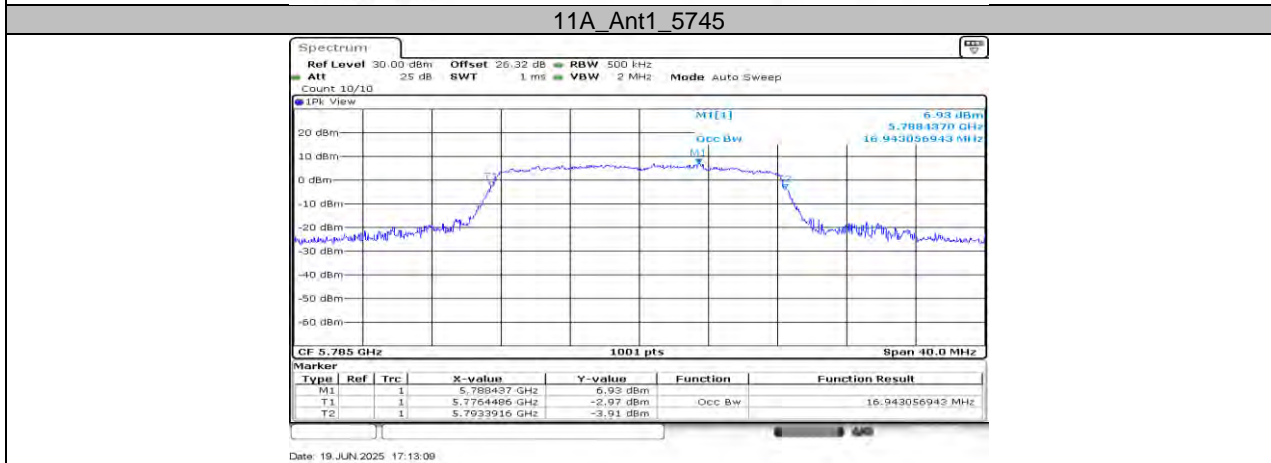
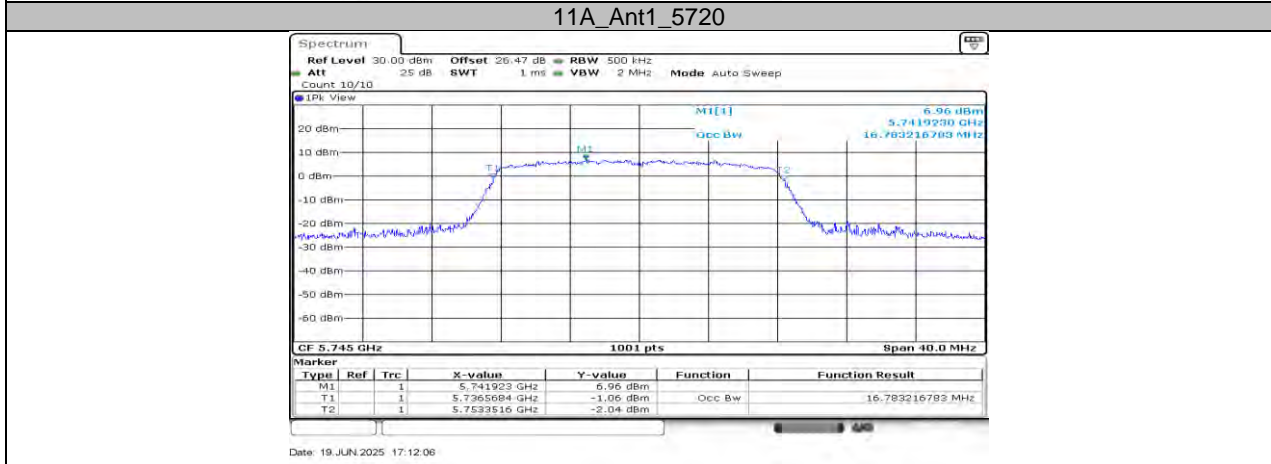
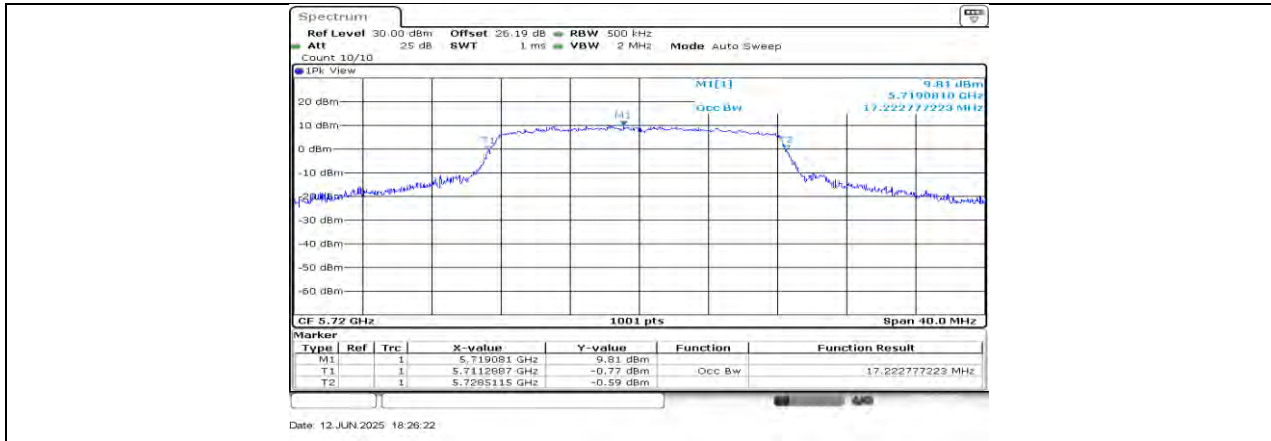



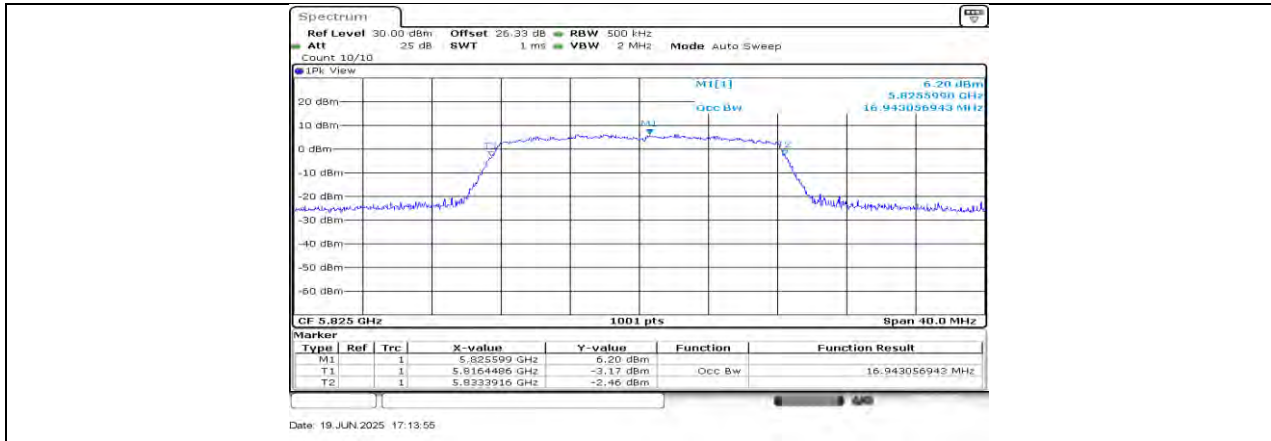

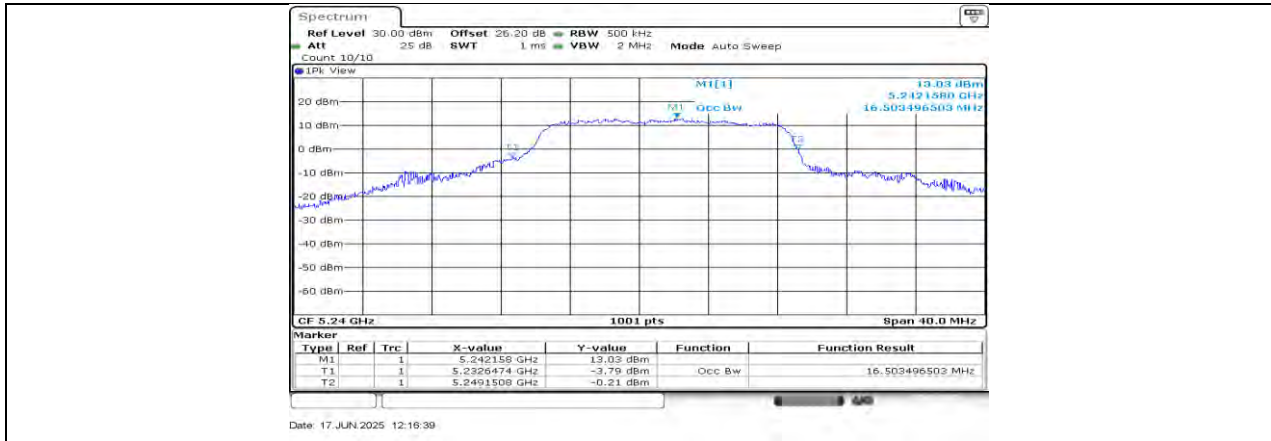

11N20SISO\_Ant1\_5240



11N20SISO\_Ant1\_5260



11N20SISO\_Ant1\_5280

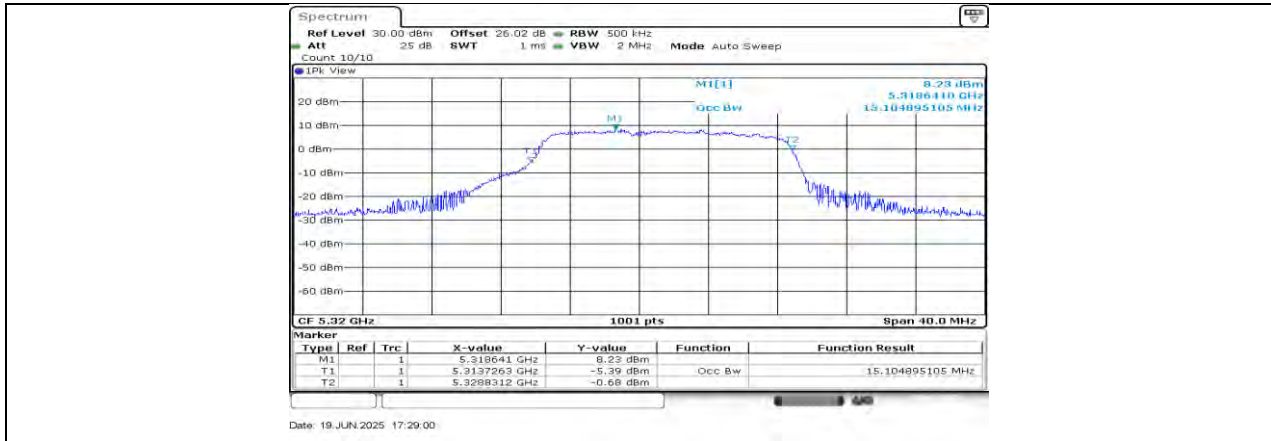

11N20SISO\_Ant1\_5320



11N20SISO\_Ant1\_5500



11N20SISO\_Ant1\_5580

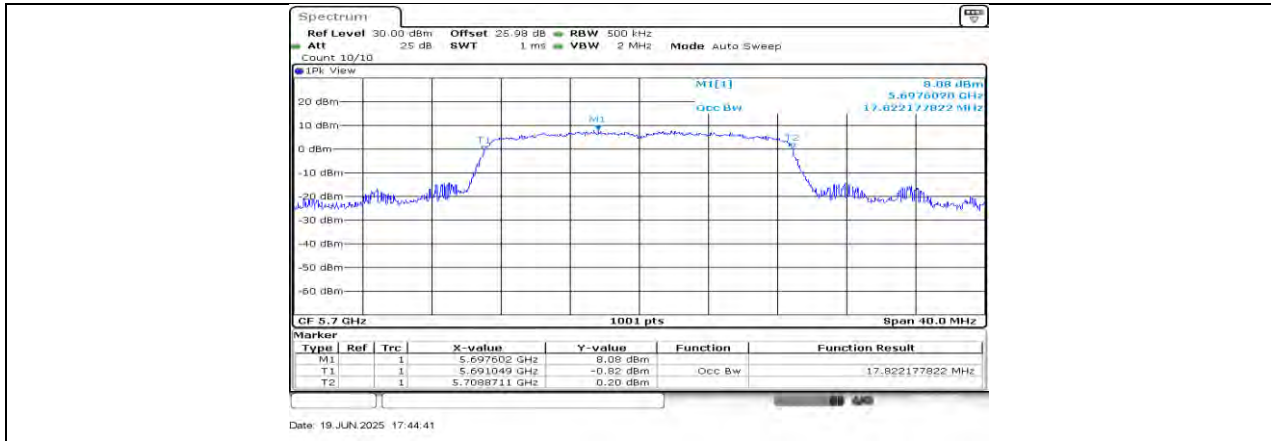

11N20SISO\_Ant1\_5700



11N20SISO\_Ant1\_5720

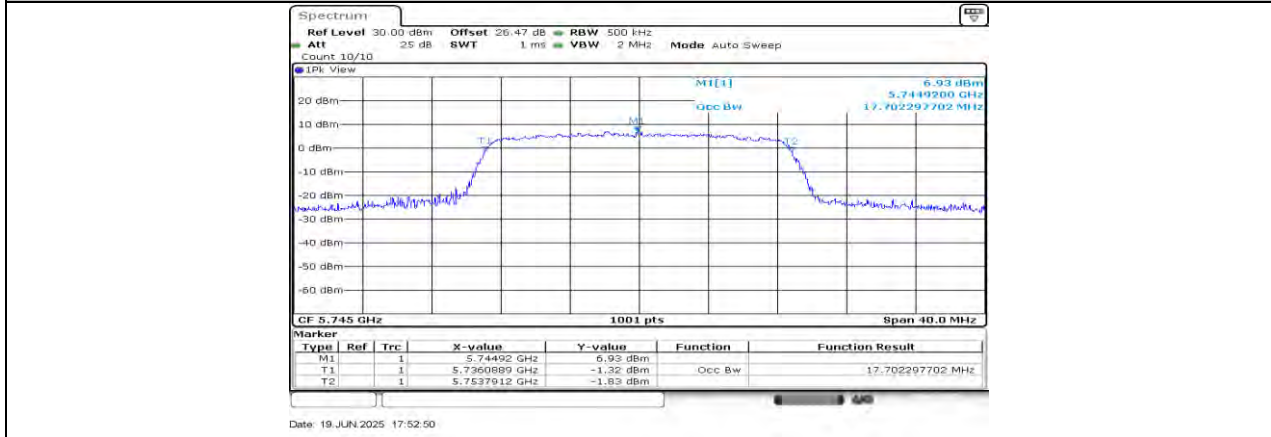

11N20SISO\_Ant1\_5745



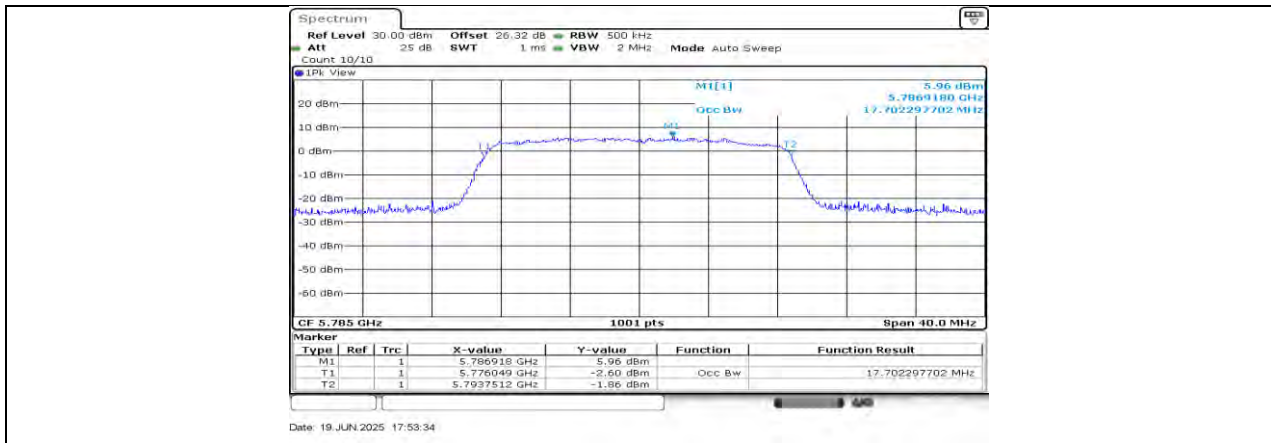

**11.3. APPENDIX C: MIN EMISSION BANDWIDTH**  
**11.3.1. Test Result**

Test Mode	Antenna	Frequency[MHz]	6db EBW [MHz]	FL[MHz]	FH[MHz]	Limit[MHz]	Verdict
11A	Ant1	5720	16.32	5711.76	5728.08	---	---
		5720_UNII-2C	13.24	5711.76	5725	---	---
		5720_UNII-3	3.08	5725	5728.08	$\geq 0.5$	PASS
		5745	15.32	5737.16	5752.48	$\geq 0.5$	PASS
		5785	16.32	5776.76	5793.08	$\geq 0.5$	PASS
		5825	15.52	5817.16	5832.68	$\geq 0.5$	PASS
11N20SISO	Ant1	5720	15.56	5712.12	5727.68	---	---
		5720_UNII-2C	12.88	5712.12	5725	---	---
		5720_UNII-3	2.68	5725	5727.68	$\geq 0.5$	PASS
		5745	17.32	5736.16	5753.48	$\geq 0.5$	PASS
		5785	15.64	5777.04	5792.68	$\geq 0.5$	PASS
		5825	15.12	5817.36	5832.48	$\geq 0.5$	PASS

### 11.3.2. Test Graphs

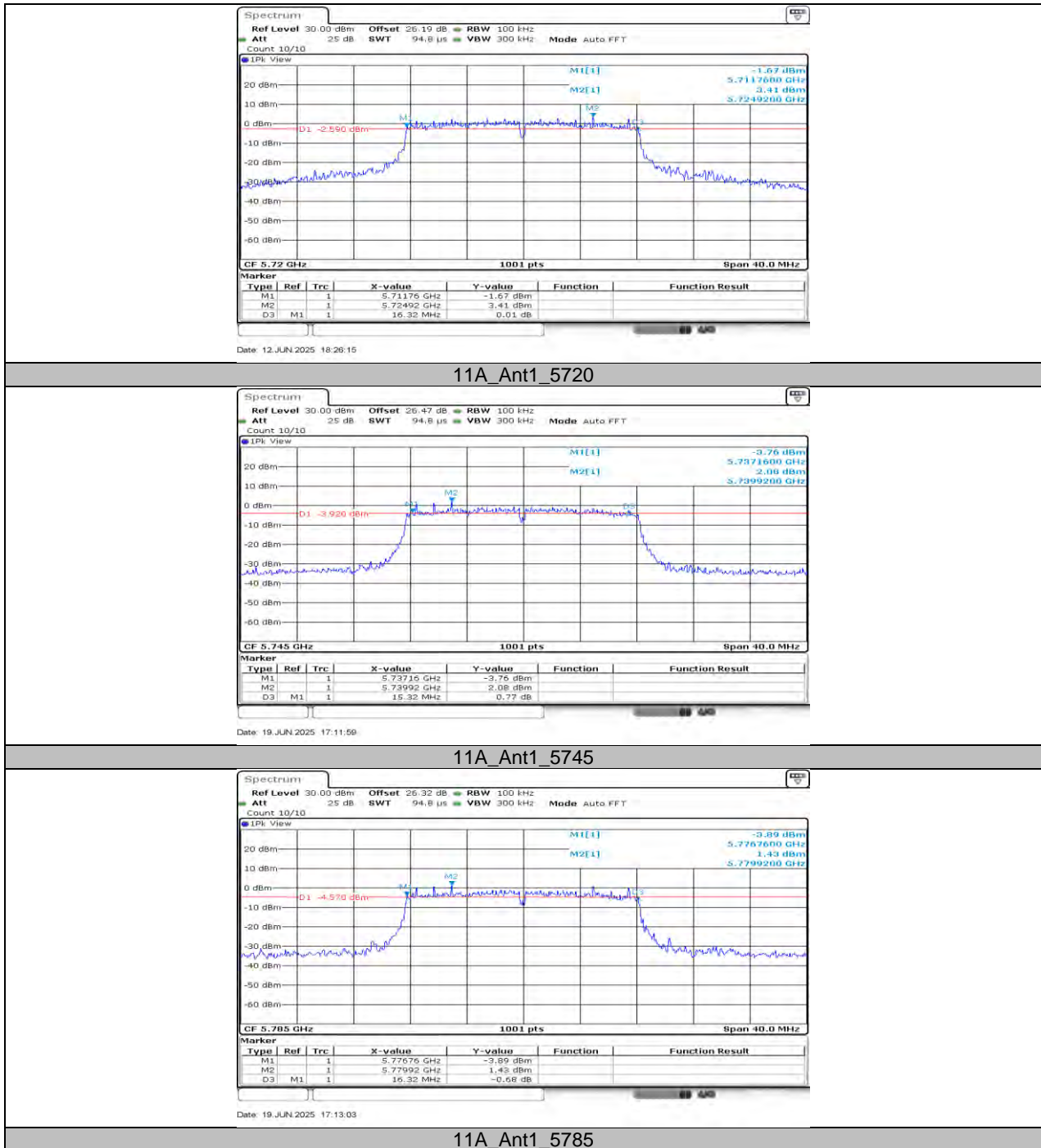

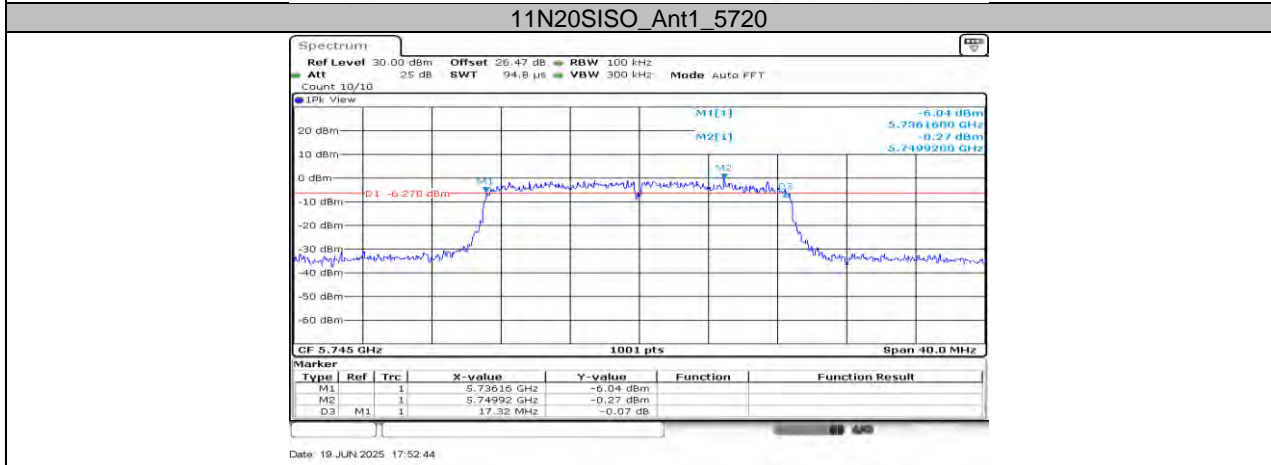
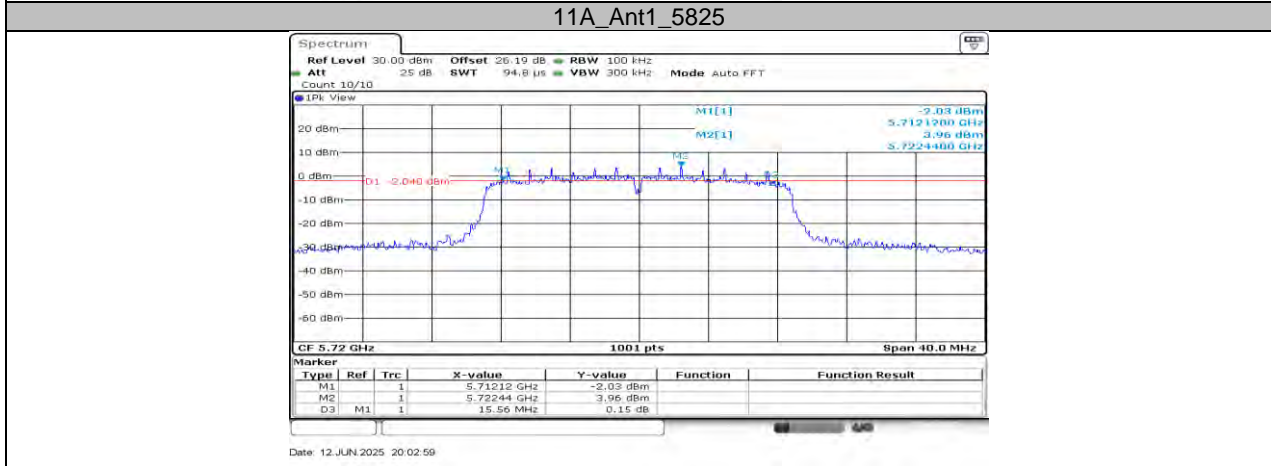
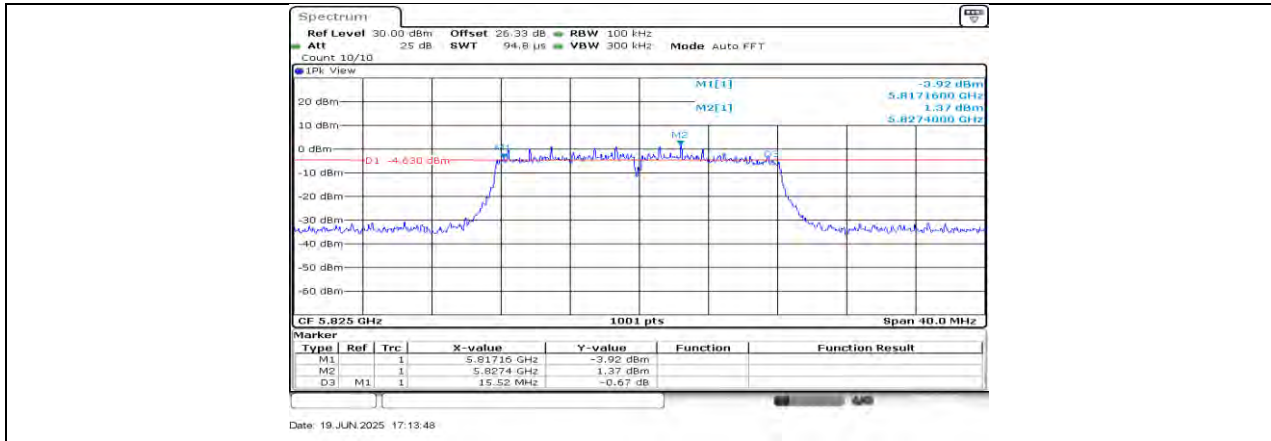

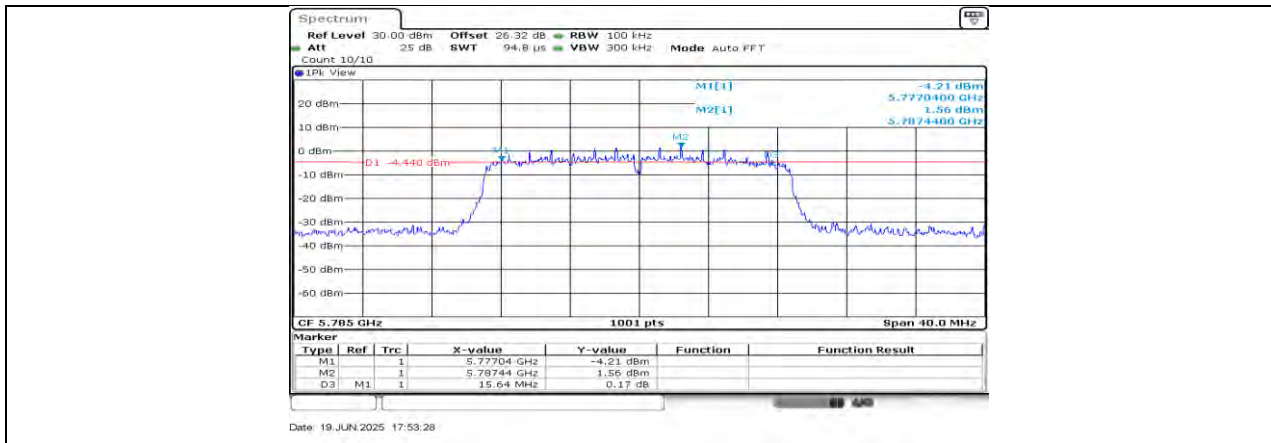

11N20SISO\_Ant1\_5785

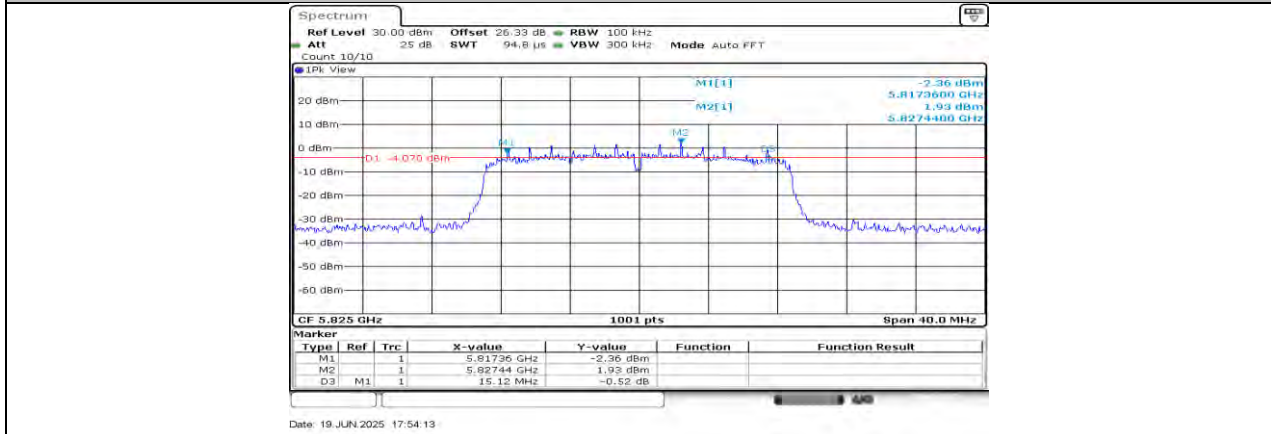

11N20SISO\_Ant1\_5825

## 11.4. APPENDIX D: MAXIMUM AVG CONDUCTED OUTPUT POWER

### 11.4.1. Test Result

Test Mode	Antenna	Frequency[MHz]	Power [dBm]	FCC Limit [dBm]	Verdict
11A	Ant1	5180	20.60	≤23.98	PASS
		5200	21.09	≤23.98	PASS
		5240	20.76	≤23.98	PASS
		5260	20.96	≤23.52	PASS
		5280	21.03	≤23.55	PASS
		5320	18.75	≤23.56	PASS
		5500	18.80	≤23.65	PASS
		5580	21.50	≤23.82	PASS
		5700	18.44	≤23.81	PASS
		5720_UNII-2C	20.16	≤23.04	PASS
		5720_UNII-3	11.75	≤30.00	PASS
		5745	22.94	≤30.00	PASS
		5785	22.28	≤30.00	PASS
		5825	21.79	≤30.00	PASS
11N20SISO	Ant1	5180	20.30	≤23.98	PASS
		5200	20.77	≤23.98	PASS
		5240	20.66	≤23.98	PASS
		5260	20.72	≤23.55	PASS
		5280	20.85	≤23.61	PASS
		5320	20.12	≤23.52	PASS
		5500	18.08	≤23.63	PASS
		5580	21.41	≤23.86	PASS
		5700	17.39	≤23.83	PASS
		5720_UNII-2C	19.64	≤22.67	PASS
		5720_UNII-3	11.60	≤30.00	PASS
		5745	22.76	≤30.00	PASS
		5785	22.13	≤30.00	PASS
		5825	21.59	≤30.00	PASS

Note: The Duty Cycle Factor is compensated in the data.



### 11.4.2. Test Graphs

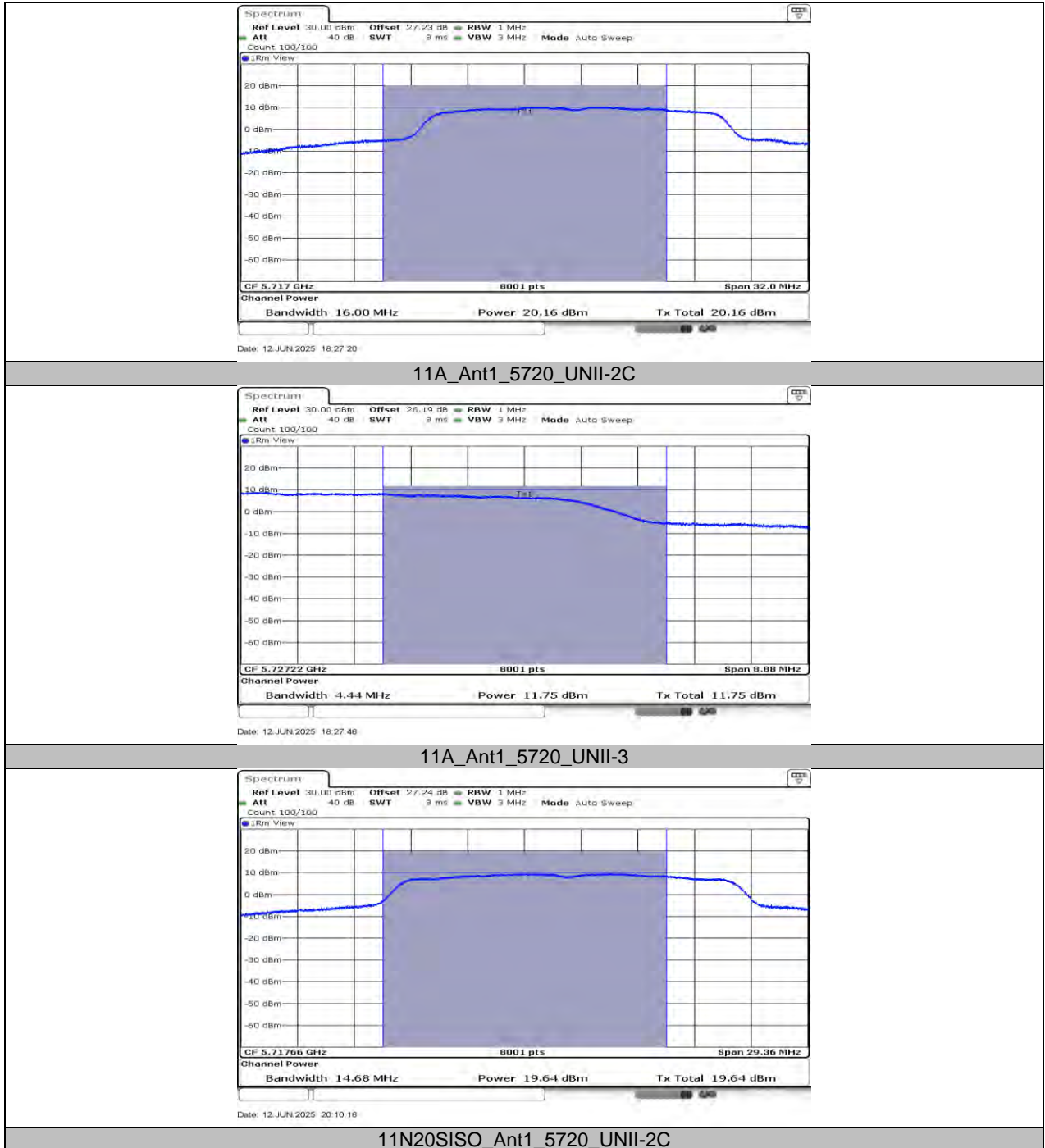





## 11.5. APPENDIX E: MAXIMUM POWER SPECTRAL DENSITY

### 11.5.1. Test Result

Test Mode	Antenna	Frequency[MHz]	Power [dBm/MHz]	Limit [dBm/MHz]	Verdict
11A	Ant1	5180	10.69	≤11.00	PASS
		5200	10.33	≤11.00	PASS
		5240	10.45	≤11.00	PASS
		5260	10.78	≤11.00	PASS
		5280	10.33	≤11.00	PASS
		5320	8.54	≤11.00	PASS
		5500	7.36	≤11.00	PASS
		5580	10.81	≤11.00	PASS
		5700	6.88	≤11.00	PASS
		5720_UNII-2C	9.96	≤11.00	PASS
		5720_UNII-3	5.80	≤30.00	PASS
		5745	9.32	≤30.00	PASS
		5785	8.67	≤30.00	PASS
		5825	8.01	≤30.00	PASS
11N20SISO	Ant1	5180	10.02	≤11.00	PASS
		5200	10.24	≤11.00	PASS
		5240	10.60	≤11.00	PASS
		5260	10.42	≤11.00	PASS
		5280	10.20	≤11.00	PASS
		5320	9.74	≤11.00	PASS
		5500	9.05	≤11.00	PASS
		5580	10.49	≤11.00	PASS
		5700	6.58	≤11.00	PASS
		5720_UNII-2C	9.33	≤11.00	PASS
		5720_UNII-3	5.59	≤30.00	PASS
		5745	8.76	≤30.00	PASS
		5785	8.07	≤30.00	PASS
		5825	7.63	≤30.00	PASS

Note: 1.The Result and Limit Unit is dBm/500 kHz in the band 5.725–5.85 GHz.

2.The Duty Cycle Factor and RBW Factor is compensated in the graph.

### 11.5.2. Test Graphs

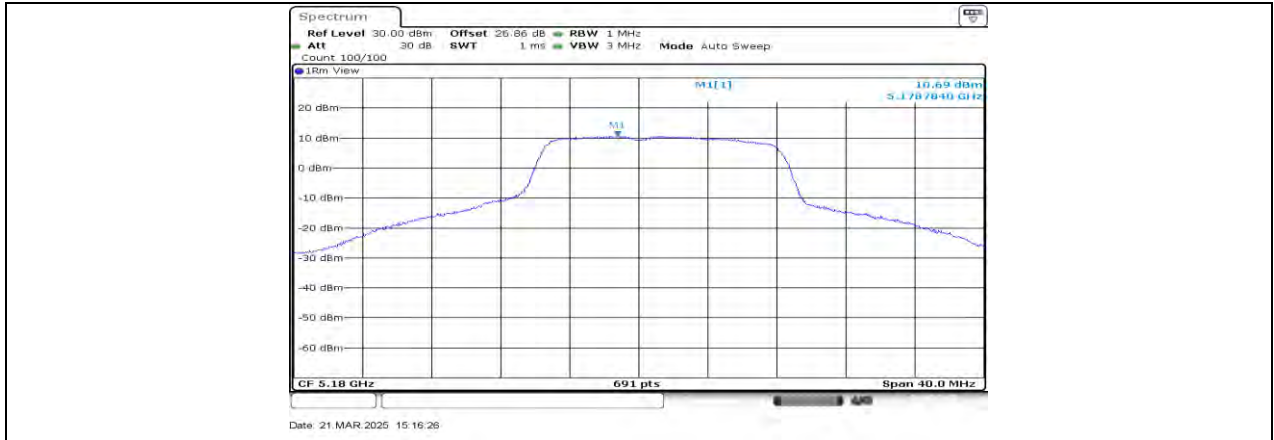

11A\_Ant1\_5180



11A\_Ant1\_5200

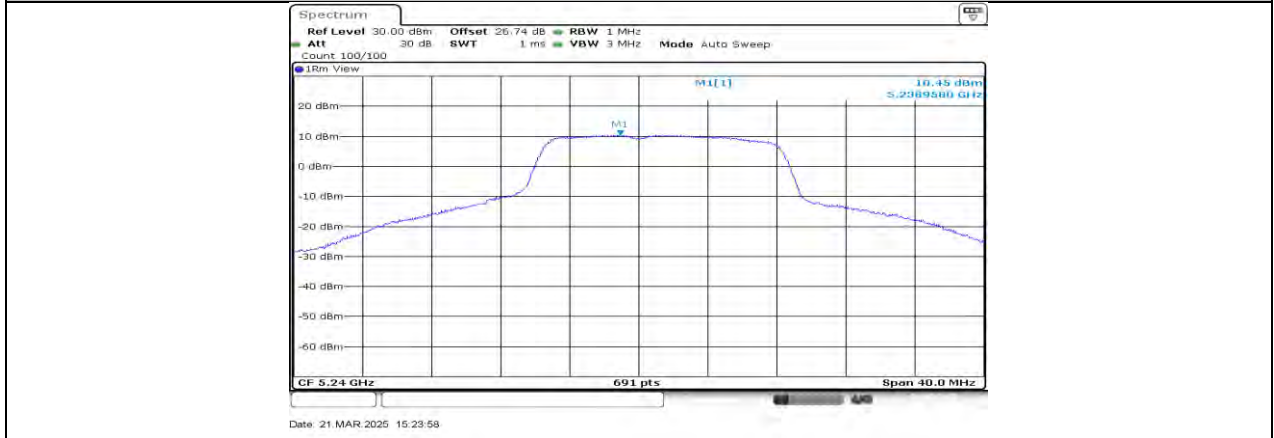

11A\_Ant1\_5240

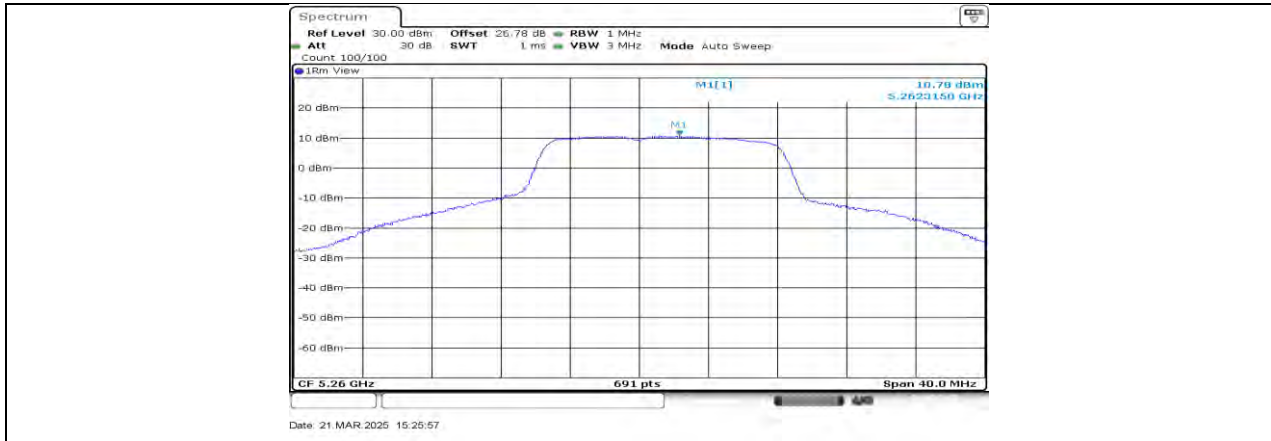

11A\_Ant1\_5260



11A\_Ant1\_5280



11A\_Ant1\_5320

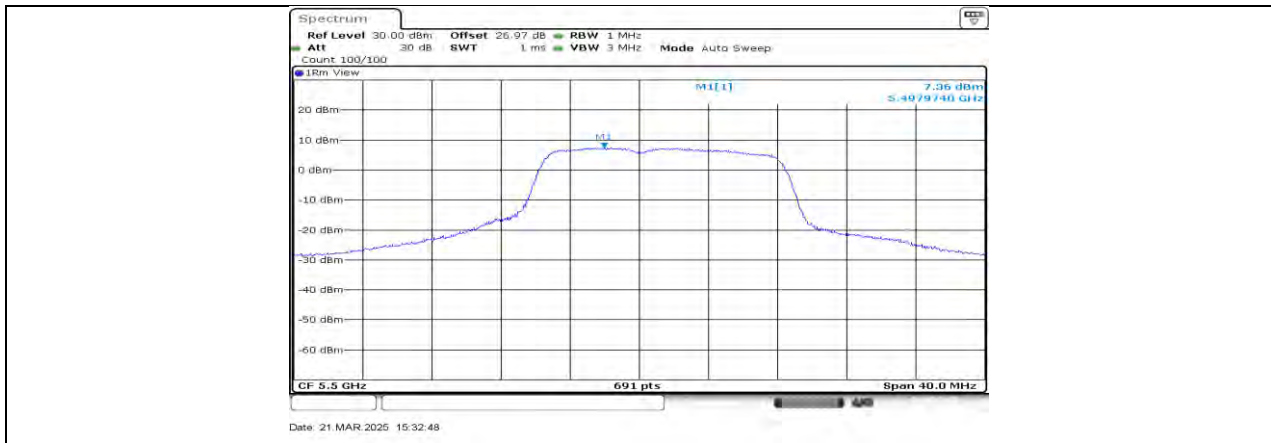

11A\_Ant1\_5500



11A\_Ant1\_5580



11A\_Ant1\_5700

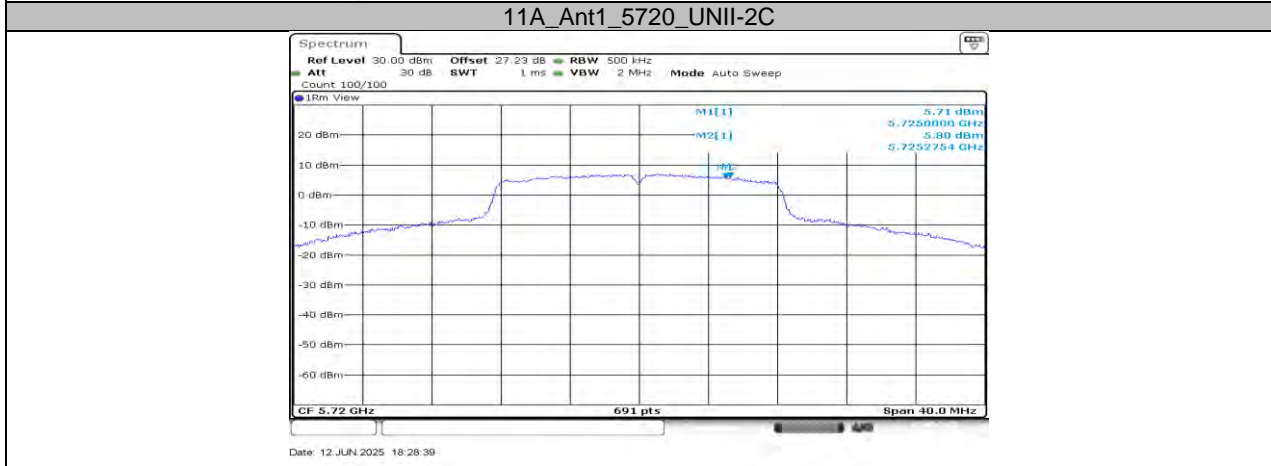

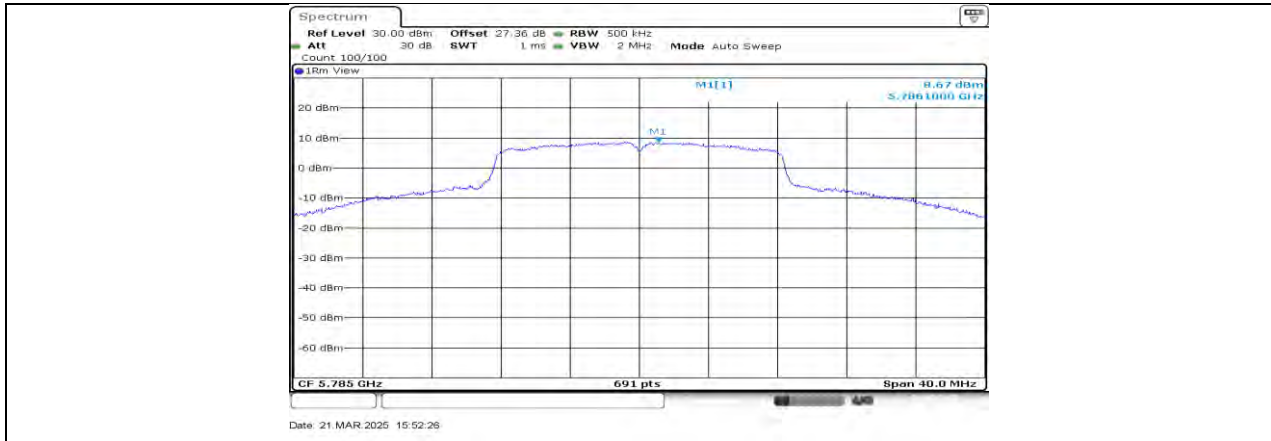

11A\_Ant1\_5785



11A\_Ant1\_5825



11N20SISO\_Ant1\_5180





11N20SISO\_Ant1\_5200



11N20SISO\_Ant1\_5240



11N20SISO\_Ant1\_5260



11N20SISO\_Ant1\_5280



11N20SISO\_Ant1\_5320



11N20SISO\_Ant1\_5500





11N20SISO\_Ant1\_5580



11N20SISO\_Ant1\_5700



11N20SISO\_Ant1\_5720\_UNII-2C





## 11.6. APPENDIX F: FREQUENCY STABILITY

### 11.6.1. Test Result

Frequency Error vs. Voltage									
802.11a:5825MHz									
Temp.	Volt.	0 Minute		2 Minute		5 Minute		10 Minute	
		Freq.Error (MHz)	Tolerance (ppm)	Freq.Error (MHz)	Tolerance (ppm)	Freq.Error (MHz)	Tolerance (ppm)	Freq.Error (MHz)	Tolerance (ppm)
TN	VL	5824.9838	-2.78	5825.0094	1.61	5824.9812	-3.23	5824.9848	-2.61
TN	VN	5825.0061	1.04	5824.9773	-3.89	5825.0075	1.29	5824.9910	-1.55
TN	VH	5824.9920	-1.37	5824.9860	-2.41	5825.0033	0.57	5825.0171	2.93

Frequency Error vs. Temperature									
802.11a:5825MHz									
Temp.	Volt.	0 Minute		2 Minute		5 Minute		10 Minute	
		Freq.Error (MHz)	Tolerance (ppm)	Freq.Error (MHz)	Tolerance (ppm)	Freq.Error (MHz)	Tolerance (ppm)	Freq.Error (MHz)	Tolerance (ppm)
45	VN	5825.0166	2.85	5824.9798	-3.46	5825.0154	2.64	5824.9965	-0.60
40	VN	5824.9954	-0.79	5825.0173	2.97	5824.9965	-0.60	5825.0204	3.50
30	VN	5825.0107	1.84	5824.9953	-0.80	5825.0024	0.42	5825.0000	0.00
20	VN	5825.0035	0.60	5825.0230	3.94	5825.0066	1.13	5825.0126	2.17
10	VN	5824.9980	-0.34	5825.0012	0.20	5824.9811	-3.24	5825.0083	1.43
0	VN	5824.9908	-1.58	5825.0107	1.83	5825.0227	3.90	5824.9963	-0.64
-10	VN	5825.0242	4.15	5824.9881	-2.04	5824.9855	-2.49	5825.0055	0.95
-20	VN	5824.9823	-3.03	5824.9914	-1.48	5824.9999	-0.02	5825.0008	0.15

**Note:**

1. All antennas, test modes and test channels have been tested, only the worst data record in the report.
2. For the detail Test Conditions, please refer to section 7.5 TEST ENVIRONMENT.

## 11.7. APPENDIX G: DUTY CYCLE

### 11.7.1. Test Result

Test Mode	On Time (msec)	Period (msec)	Duty Cycle x (Linear)	Duty Cycle (%)	Duty Cycle Correction Factor (dB)	1/T Minimum VBW (kHz)	Final setting For VBW (kHz)
11A	1.37	1.74	0.7874	78.74	1.04	0.73	1
11N20SISO	1.28	1.63	0.7853	78.53	1.05	0.78	1

Note:

Duty Cycle Correction Factor=10log (1/x).

Where: x is Duty Cycle (Linear)

Where: T is On Time

If that calculated VBW is not available on the analyzer then the next higher value should be used.

### 11.7.2. Test Graphs

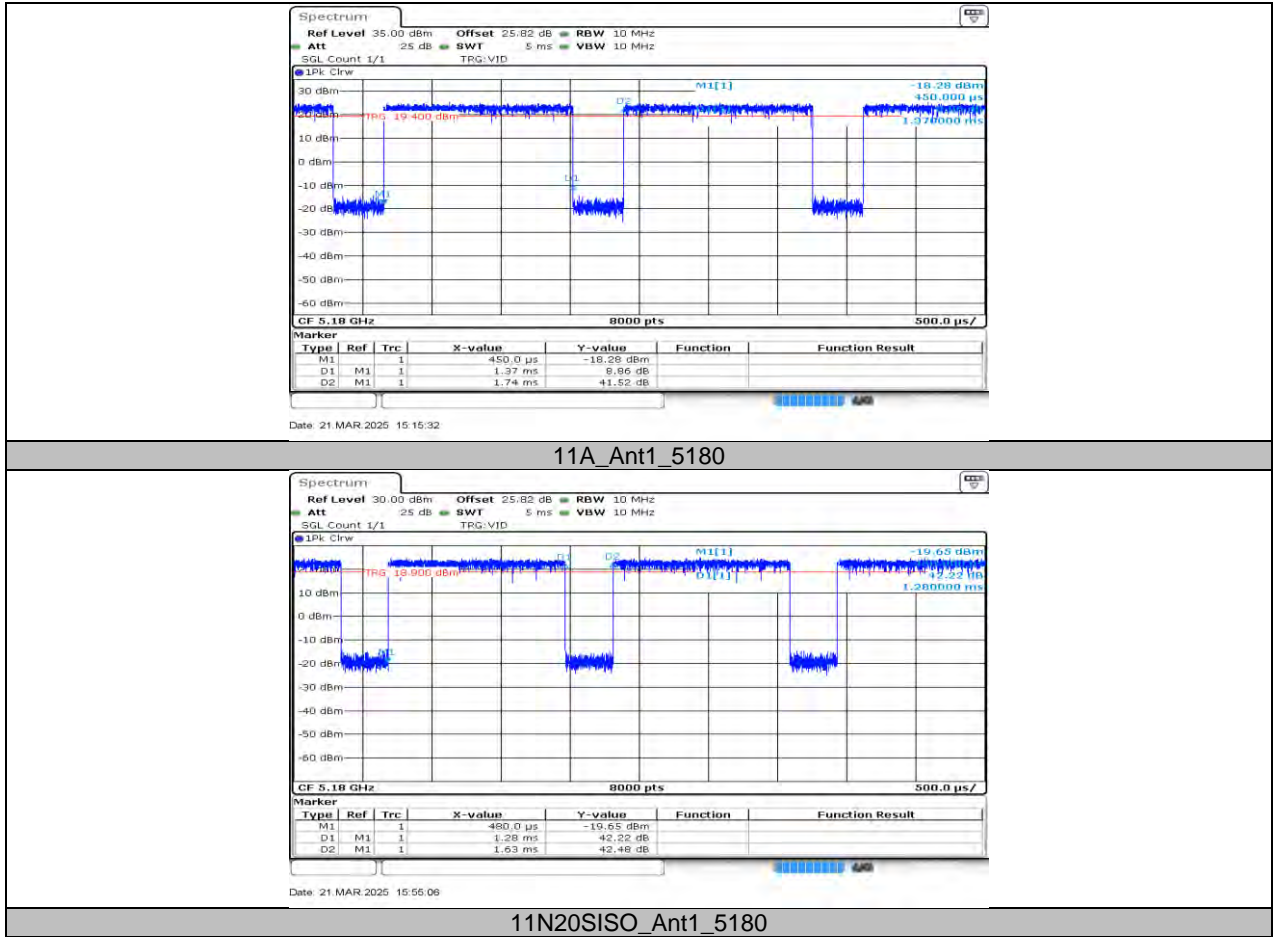

### 11.8. APPENDIX H: CALIBRATION

Mode	Frequency (MHz)	Type	Result	Verdict
n20	5500	DFS_FCC_T0	See test Graph	Pass

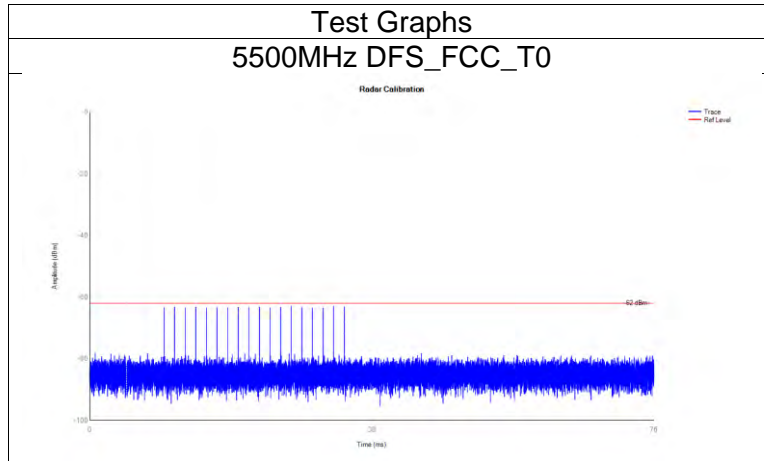

### 11.9. APPENDIX I: SHUTDOWN TIME

Mode	Frequency (MHz)	Channel Move Time (s)	Limit Channel Move Time (s)	Close Transmission Time (s)	Limit Close Transmission Time (s)	Close Transmission Time after 200ms(s)	Limit Close Transmission Time after 200ms (s)	Verdict
n20	5500	0.539	10	0.019	0.26	0.005	0.06	Pass

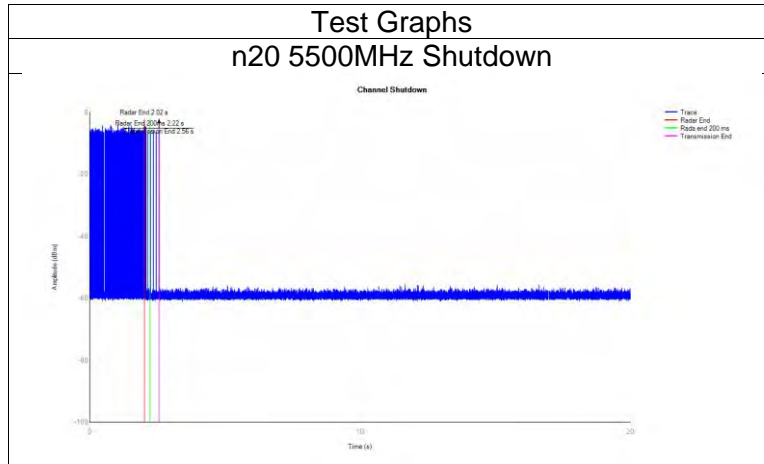



### 11.10. APPENDIX J: NON-OCCUPANCY

Mode	Frequency (MHz)	Result	Verdict
n20	5500	See test Graph	Pass

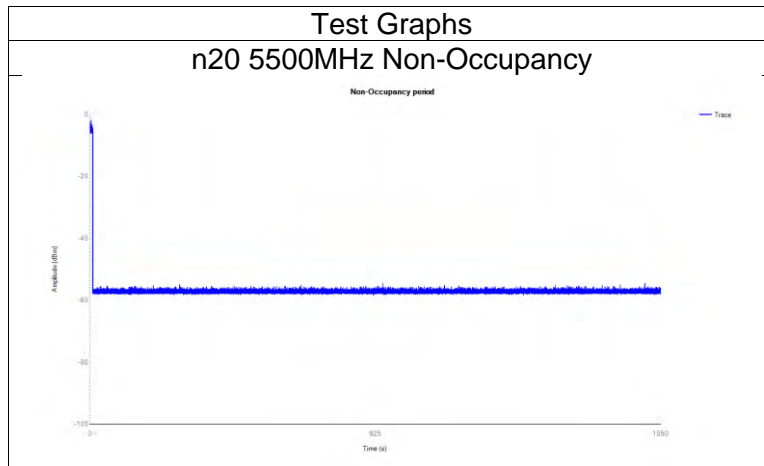

**END OF REPORT**