



RF TEST REPORT

Applicant Flextronics (Shanghai) Co., Ltd

FCC ID 2AP3PAPOC

Product AT100 series (AT100, AT130) – Wired asset tracker
TT400 series (TT400, TT401) – Wired trailer tracker
FT500 series (FT500) – In-cab telematics tracker

Model AT100-LM0Q-GL, AT130-LM0Q-GL,
TT400-LM0Q-GL, FT500-LM0Q-GL
TT401-LM0Q-GL

Report No. R1908A0461-R18

Issue Date November 22, 2019

TA Technology (Shanghai) Co., Ltd. tested the above equipment in accordance with the requirements in **FCC CFR47 Part 2 (2018)/ FCC CFR47 Part 27C (2018)**. The test results show that the equipment tested is capable of demonstrating compliance with the requirements as documented in this report.

Performed by: Peng Tao

Approved by: Kai Xu

TA Technology (Shanghai) Co., Ltd.

No.145, Jintang Rd, Tangzhen Industry Park, Pudong Shanghai, China

TEL: +86-021-50791141/2/3

FAX: +86-021-50791141/2/3-8000



TABLE OF CONTENT

1	Test Laboratory.....	4
1.1	Notes of the Test Report.....	4
1.2	Testing Location.....	4
2	General Description of Equipment under Test.....	5
2.1	Applicant and Manufacturer Information.....	5
2.2	General information.....	5
3	Applied Standards.....	7
4	Test Configuration.....	8
5	Test Case Results.....	9
5.1	RF Power Output and Effective Radiated Power.....	9
5.2	Occupied Bandwidth.....	12
5.3	Band Edge Compliance.....	17
5.4	Peak-to-Average Power Ratio (PAPR).....	20
5.5	Frequency Stability.....	22
5.6	Spurious Emissions at Antenna Terminals.....	25
5.7	Radiates Spurious Emission.....	27
6	Main Test Instruments.....	32



Summary of Measurement Results

Number	Test Case	Clause in FCC rules	Verdict
1	RF power output and Effective Radiated Power	2.1046 27.50(d)(4)	PASS
2	Occupied Bandwidth	2.1049	PASS
3	Band Edge Compliance	27.53(h)	PASS
4	Peak-to-Average Power Ratio	27.50(d)/KDB971168 D01(5.7)	PASS
5	Frequency Stability	2.1055 / 27.54	PASS
6	Spurious Emissions at Antenna Terminals	2.1051 /27.53(h)	PASS
7	Radiates Spurious Emission	2.1053 /27.53(h)	PASS
Note: PASS: The EUT complies with the essential requirements in the standard. FAIL: The EUT does not comply with the essential requirements in the standard.			
Date of Testing: August 26, 2019 ~ October 31, 2019			



1 Test Laboratory

1.1 Notes of the Test Report

This report shall not be reproduced in full or partial, without the written approval of **TA technology (shanghai) co., Ltd.** The results documented in this report apply only to the tested sample, under the conditions and modes of operation as described herein .Measurement Uncertainties were not taken into account and are published for informational purposes only. This report is written to support regulatory compliance of the applicable standards stated above.

1.2 Testing Location

Company: TA Technology (Shanghai) Co., Ltd.
Address: No.145, Jintang Rd, Tangzhen Industry Park, Pudong Shanghai, China
City: Shanghai
Post code: 201201
Country: P. R. China
Contact: Xu Kai
Telephone: +86-021-50791141/2/3
Fax: +86-021-50791141/2/3-8000
Website: <http://www.ta-shanghai.com>
E-mail: xukai@ta-shanghai.com

2 General Description of Equipment under Test

2.1 Applicant and Manufacturer Information

Applicant	Flextronics (Shanghai) Co., Ltd
Applicant address	4F, Bldg. 10, No. 3000 Longdong Ave., Pudong New District, Shanghai, China, 201203
Manufacturer	Flex Industrial, Ltd.
Manufacturer address	Level 3, Alexander House, 35 Cybercity, Ebene, Mauritius

2.2 General information

EUT Description			
Model	AT100-LM0Q-GL, AT130-LM0Q-GL, TT400-LM0Q-GL, FT500-LM0Q-GL, TT401-LM0Q-GL		
IMEI	866425038986982		
Hardware Version	P2.1		
Software Version	2.1.29		
Power Supply	Battery		
Antenna Type	Internal Antenna		
Antenna Gain	1dBi		
Test Mode(s)	NB-IOT Band 4;		
Test Modulation	BPSK, QPSK		
Category	NB1		
Deployment	stand-alone		
Sub-carrier spacing	3.75KHz, 15KHz		
Ntones	single, multi-tone		
Maximum E.I.R.P.	NB-IOT Band 4:	22.01dBm	
Rated Power Supply Voltage:	12V		
Extreme Voltage	Minimum: 6V Maximum: 48V		
Extreme Temperature	Lowest: -40°C Highest: +85°C		
Operating Frequency Range(s)	Mode	Tx (MHz)	Rx (MHz)
	NB-IOT Band 4	1710 ~ 1755	2110 ~ 2155
EUT Accessory			
Battery 1 (AT100-LM0Q-GL, FT500-LM0Q-GL)	Manufacturer: Hangzhou Future Power Technology Co., Ltd Model: FT553561P		
Battery2 (AT130-LM0Q-GL, TT400-LM0Q-GL,	Manufacturer: INVENTUS POWER, INC. – DESIGN CENTER Model: 57484-001		



TT401-LM0Q-GL)

Note: 1. The information of the EUT is declared by the manufacturer.
2. There are more than one Battery, each one should be applied throughout the compliance test respectively, however, only the worst case (Battery1) will be recorded in this report.

The difference between AT100-LM0Q-GL, AT130-LM0Q-GL, TT400-LM0Q-GL, FT500-LM0Q-GL, TT401-LM0Q-GL please refer to *APOC Difference Information*.

However, only the worst model FT500-LM0Q-GL will be recorded in this report.



3 Applied Standards

According to the specifications of the manufacturer, it must comply with the requirements of the following standards:

Test standards:

FCC CFR47 Part 27C (2018)

ANSI C63.26 (2015)

Reference standard:

FCC CFR47 Part 2 (2018)

KDB 971168 D01 Power Meas License Digital Systems v03r01

4 Test Configuration

Radiated measurements are performed by rotating the EUT in three different orthogonal test planes. EUT stand-up position (Z axis), lie-down position (X, Y axis). Receiver antenna polarization (horizontal and vertical), the worst emission was found in position (Z axis, horizontal polarization) and the worst case was recorded.

All modes as Subcarrier Spacing, modulations, Channel were investigated.

Subsequently, only the worst case emissions are reported.

The following testing in NB-IOT is set based on the maximum RF Output Power.

The following testing in different mode is set to detail in the following table:

Test modes are chosen to be reported as the worst case configuration below for NB-IOT Band 4:

Test items	Mode	Deployment mode	Subcarrier Spacing (kHz)		Modulation		Test Channel		
		Stand-alone	3.75	15	BPSK	QPSK	L	M	H
RF power output and Effective Isotropic Radiated power	NB-IOT B4	O	O	O	O	O	O	O	O
Occupied Bandwidth	NB-IOT B4	O	O	O	O	O	O	O	O
Band Edge Compliance	NB-IOT B4	O	O	O	O	O	O	-	O
Peak-to-Average Power Ratio	NB-IOT B4	O	O	O	O	O	-	O	-
Frequency Stability	NB-IOT B4	O	O	O	O	O	O	O	O
Conducted Spurious Emissions	NB-IOT B4	O	-	O	-	O	O	O	O
Radiates Spurious Emission	NB-IOT B4	O	-	O	-	O	O	O	O
<p>Note</p> <ol style="list-style-type: none"> 1. The mark "O" means that this configuration is chosen for testing. 2. The mark "-" means that this configuration is not testing. 									

5 Test Case Results

5.1 RF Power Output and Effective Radiated Power

Ambient condition

Temperature	Relative humidity	Pressure
23°C ~25°C	45%~50%	101.5kPa

Methods of Measurement

During the process of the testing, The EUT is controlled by the Base Station Simulator to ensure max power transmission and proper modulation.

1. The testing follows FCC KDB 971168 D01 v03r01 Section 5.8 and ANSI C63.26 (2015).

- a) Connect the equipment as illustrated. Mount the equipment with the manufacturer specified antenna in a vertical orientation on a manufacturer specified mounting surface located on a non-conducting rotating platform of a RF anechoic chamber (preferred) or a standard radiation site.
- b) Key the transmitter, then rotate the EUT 360° azimuthally and record spectrum analyzer power level (LVL) measurements at angular increments that are sufficiently small to permit resolution of all peaks. If a standard radiation test site is used, raise and lower the test antenna to obtain a maximum reading at each angular increment. (Note: several batteries may be needed to offset the effect of battery voltage droop, which should not exceed 5% of the manufactured specified battery voltage during transmission).
- c) Replace the transmitter under test with a vertically polarized half-wave dipole (or an antenna whose gain is known relative to an ideal half-wave dipole). The center of the antenna should be at the same location as the center of the antenna under test.
- d) Connect the antenna to a signal generator with a known output power and record the path loss (in dB) as LOSS. If a standard radiation test site is used, raise and lower the test antenna to obtain a maximum reading. $LOSS = \text{Generator Output Power (dBm)} - \text{Analyzer reading (dBm)}$
- e) Determine the effective radiated output power at each angular position from the readings in steps b) and d) using the following equation: $ERP \text{ (dBm)} = \text{LVL (dBm)} + \text{LOSS (dB)}$
- f) The maximum ERP is the maximum value determined in the preceding step.
- g) When calculating ERP, in addition to knowing the antenna radiation and matching characteristics, it is necessary to know the loss values of all elements (e.g.transmission line attenuation, mismatches, filters, combiners) interposed between the point where transmitter output power is measured, and the point where power is applied to the antenna. ERP can then be calculated as follows:
 $EIRP \text{ (dBm)} = \text{Output Power (dBm)} - \text{Losses (dB)} + \text{Antenna Gain (dBi)}$
 where:dBd refers to gain relative to an ideal dipole.
 $EIRP \text{ (dBm)} = ERP \text{ (dBm)} + 2.15 \text{ (dB.)}$

The RB allocation refers to section 5.1, using the maximum output power configuration.

Test Setup

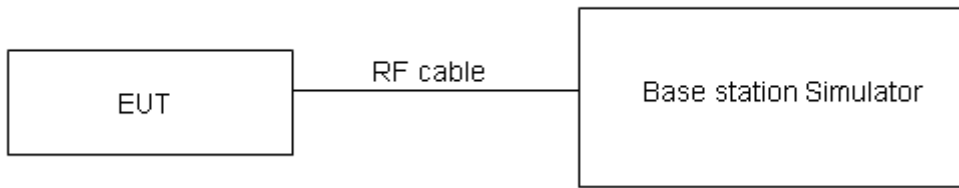

The loss between RF output port of the EUT and the input port of the tester has been taken into consideration.

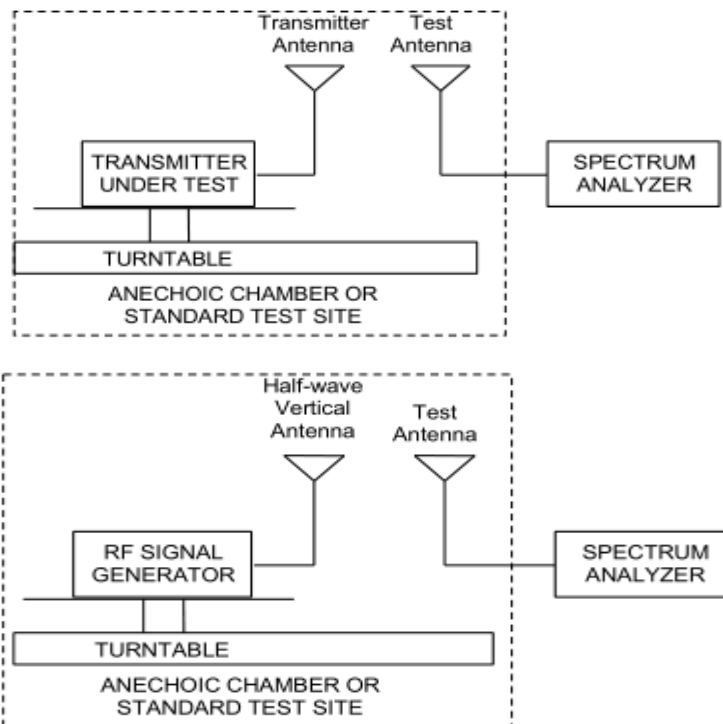

Note: Area side:2.4mX3.6m

The radiated emission was measured in the following position: EUT stand-up position (Z axis), lie-down position (X, Y axis). The worst emission was found in stand-up position (Z axis) and the worst case was recorded.

Limits

No specific RF power output requirements in part 2.1046.

Rule Part 27.50(d) (4) specifies that “Fixed, mobile and portable (hand-held) stations operating in the 1710–1755 MHz band are limited to 1 watt EIRP”

Part 27.50(d)(4)Limit	≤ 1 W (30 dBm)
-----------------------	----------------

Measurement Uncertainty

The assessed measurement uncertainty to ensure 95% confidence level for the normal distribution is with the coverage factor $k = 2$, $U=0.4$ dB for RF power output, $k = 2$, $U= 1.19$ dB for EIRP.

**Test Results**

Mode	Modulation	Sub-carrier spacing (KHz)	Ntones	Conducted Power (dBm) for low/mid/high channel					
				19951/1710.1	EIRP	20175/1732.5	EIRP	20399/1754.9	EIRP
Band 4 Standalone	BPSK	3.75	1@0	20.34	21.34	20.55	21.55	20.34	21.34
			1@47	20.30	21.30	20.50	21.50	20.30	21.30
		15	1@0	20.46	21.46	20.75	21.75	20.94	21.94
			1@11	20.41	21.41	20.70	21.70	20.95	21.95
	QPSK	3.75	1@0	20.31	21.31	20.52	21.52	20.35	21.35
			1@47	20.36	21.36	20.47	21.47	20.31	21.31
		15	1@0	20.34	21.34	20.63	21.63	20.88	21.88
			1@11	20.44	21.44	20.67	21.67	21.07	22.07
		15	12@0	20.80	21.80	21.01	22.01	21.15	22.15

5.2 Occupied Bandwidth

Ambient condition

Temperature	Relative humidity	Pressure
23°C ~25°C	45%~50%	101.5kPa

Method of Measurement

The EUT was connected to Spectrum Analyzer and Base Station Simulator via power Splitter. The occupied bandwidth is measured using spectrum analyzer.

RBW is set to 2kHz, VBW is set to 6.2kHz for NB-IOT Band 4

99% power and -26dBc occupied bandwidths are recorded. Spectrum analyzer plots are included on the following pages.

Test Setup

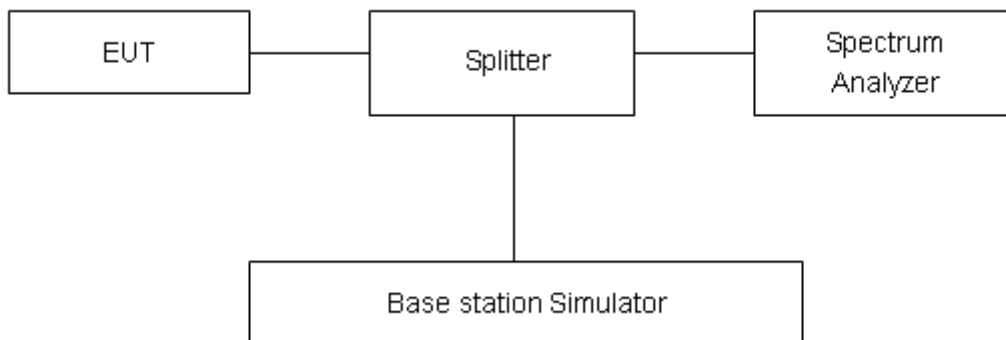

Limits

No specific occupied bandwidth requirements in part 2.1049.

Measurement Uncertainty

The assessed measurement uncertainty to ensure 95% confidence level for the normal distribution is with the coverage factor $k = 2$, $U=624\text{Hz}$.

**Test Result**

NB-IOT Band 4								
Modulation	Sub-carrier spacing (KHz)	Ntones	Bandwidth(KHz) for low/mid/high channel					
			19951/1710.1		20175/1732.5		20399/1754.9	
			99% Power	-26dBc	99% Power	-26dBc	99% Power	-26dBc
QPSK	3.75	1@0	73.81	40.01	75.70	39.65	73.07	42.42
BPSK	3.75	1@0	67.89	38.07	71.84	38.12	64.04	37.56
QPSK	15	1@0	133.57	116.70	135.49	116.90	131.30	114.30
QPSK	15	12@0	185.15	240.20	185.15	261.10	184.03	242.60
BPSK	15	1@0	143.99	121.40	143.97	198.90	139.49	101.50



NB-IOT Band 4 QPSK 3.75KHz 1@0 CH-Low

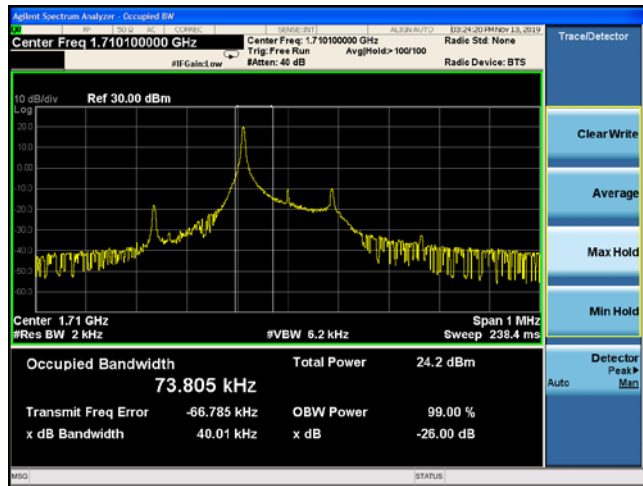

NB-IOT Band 4 BPSK 3.75KHz 1@0 CH-Low

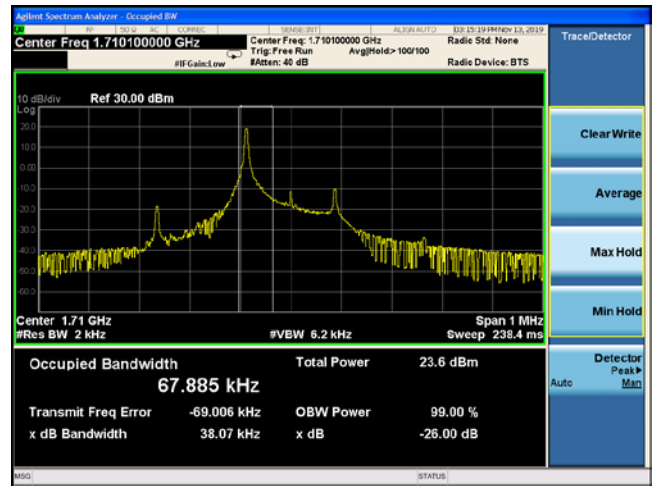

NB-IOT Band 4 QPSK 3.75KHz 1@0 CH-Middle

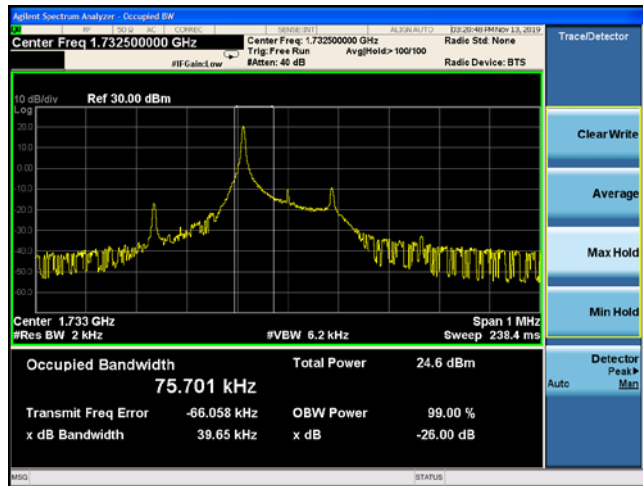

NB-IOT Band 4 BPSK 3.75KHz 1@0 CH-Middle

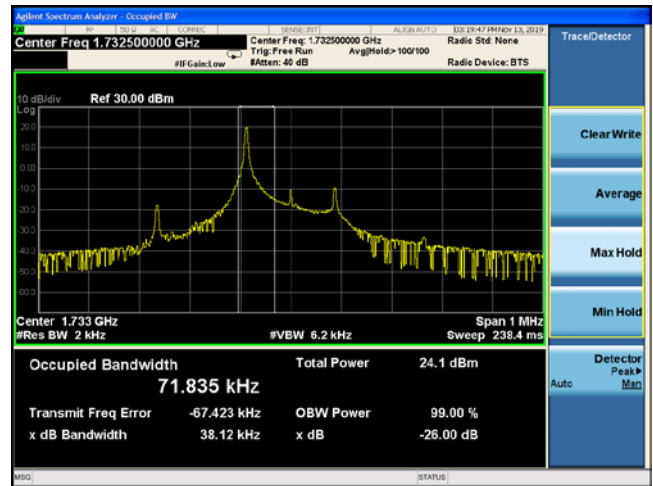

NB-IOT Band 4 QPSK 3.75KHz 1@0 CH-High

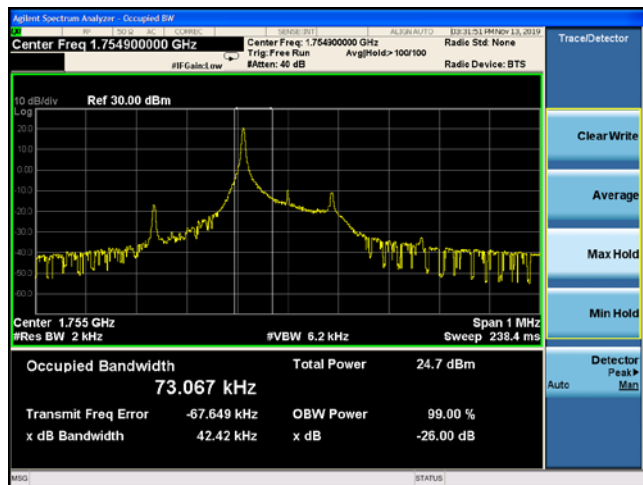

NB-IOT Band 4 BPSK 3.75KHz 1@0 CH-High

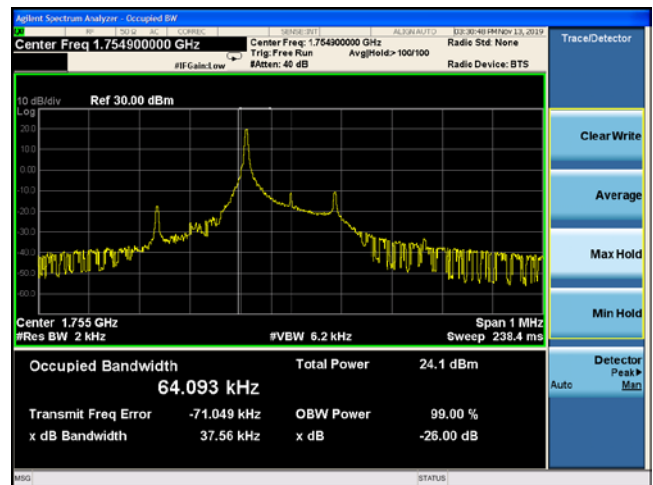



NB-IOT Band 4 QPSK 15KHz 1@0 CH-Low

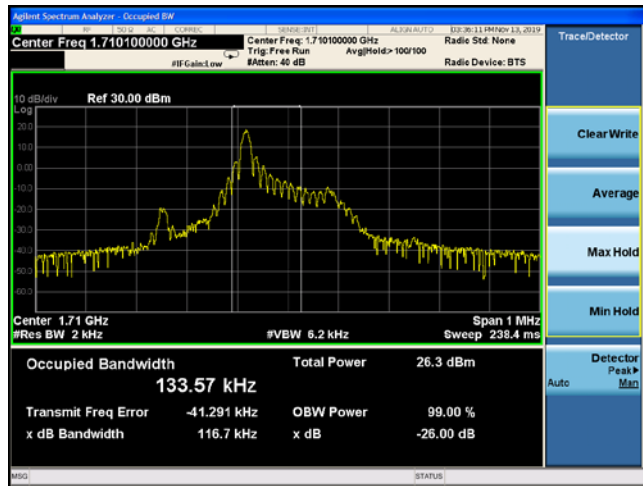

NB-IOT Band 4 QPSK 15KHz 12@0 CH-Low

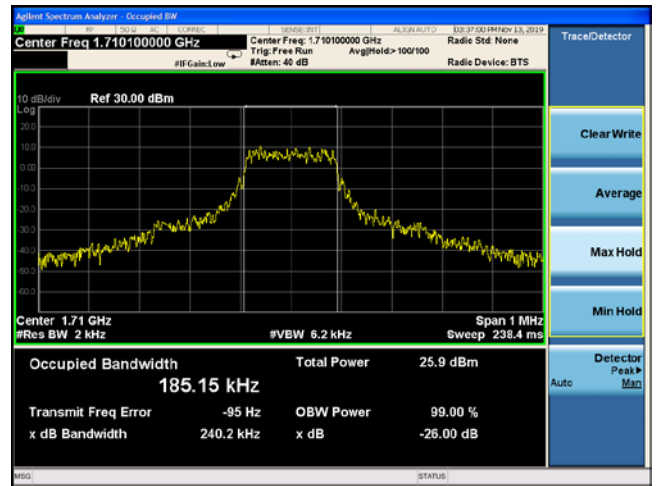

NB-IOT Band 4 QPSK 15KHz 1@0 CH-Middle

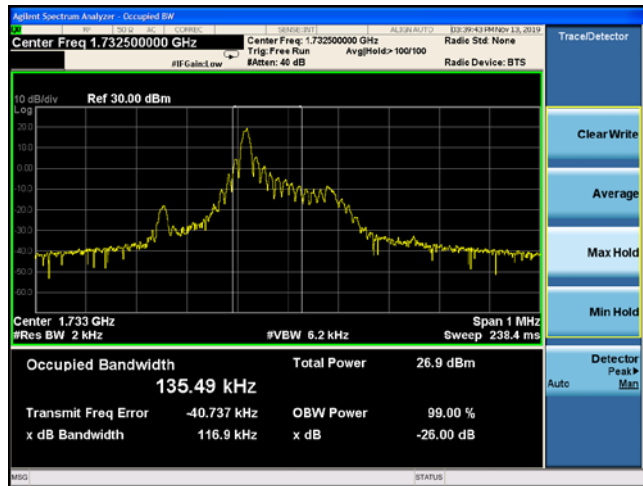

NB-IOT Band 4 QPSK 15KHz 12@0 CH-Middle

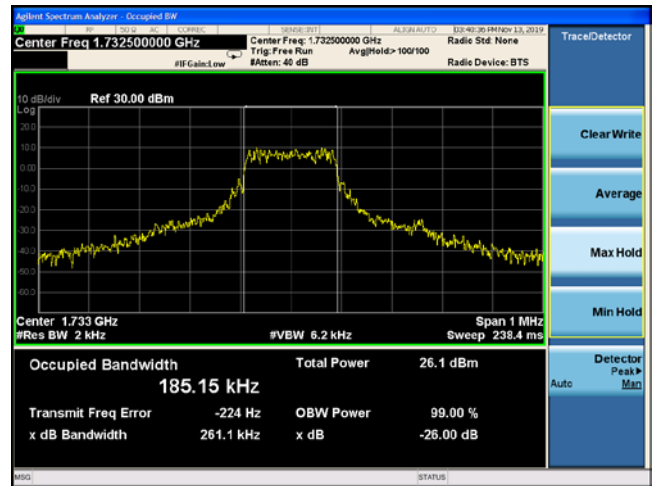

NB-IOT Band 4 QPSK 15KHz 1@0 CH-High

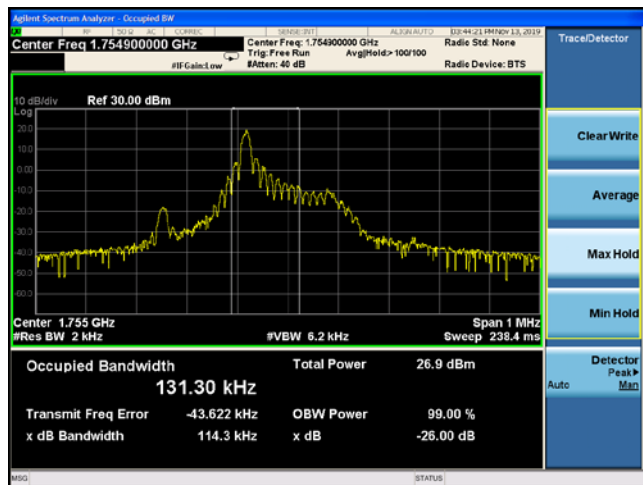

NB-IOT Band 4 QPSK 15KHz 12@0 CH-High

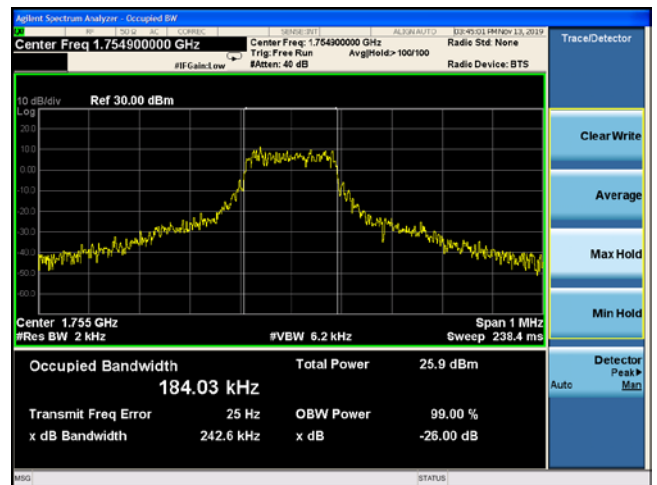

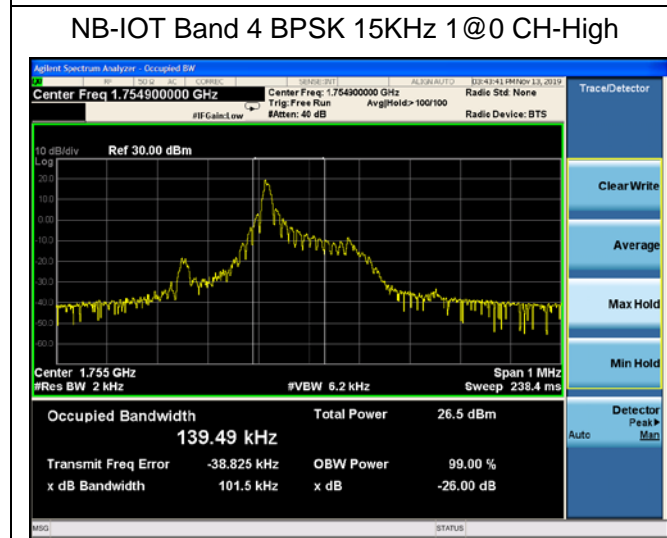
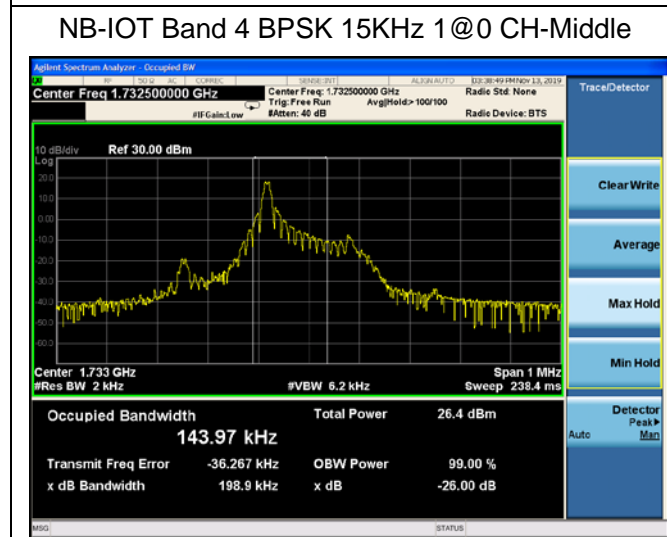
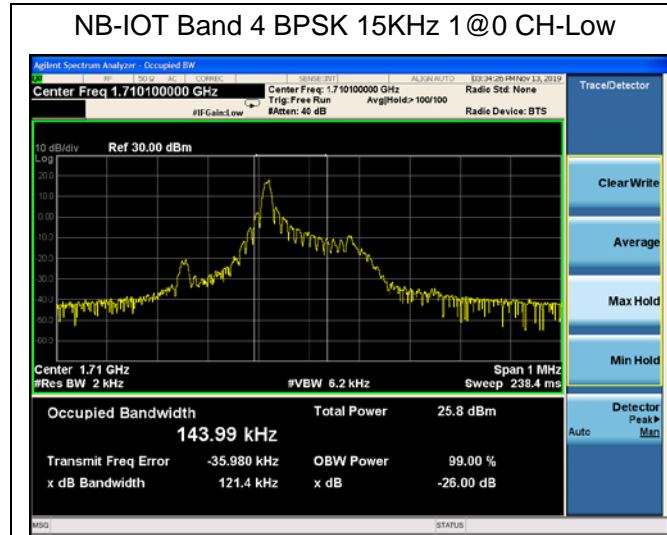

5.3 Band Edge Compliance

Ambient condition

Temperature	Relative humidity	Pressure
23°C ~25°C	45%~50%	101.5kPa

Method of Measurement

The EUT was connected to Spectrum Analyzer and Base Station Simulator via power Splitter. The band edge of the lowest and highest channels were measured.

The testing follows KDB 971168 D01 v03r01 Section 6.0

The EUT was connected to spectrum analyzer and system simulator via a power divider.

The band edges of low and high channels for the highest RF powers were measured.

RBW is set to $\geq 1\%EBW$, VBW is set to 3x RBW.

on spectrum analyzer.

Set spectrum analyzer with RMS detector.

The RF fundamental frequency should be excluded against the limit line in the operating frequency band.

Checked that all the results comply with the emission limit line.

Test Setup

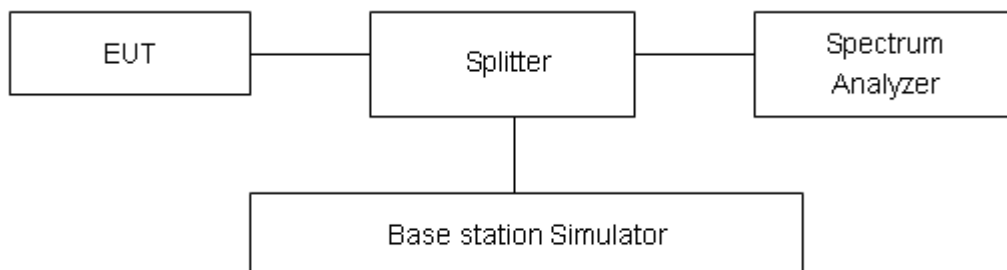

Limits

Rule Part 27.53(h) specifies that “ for operations in the 1695-1710 MHz, 1710-1755 MHz, 1755-1780 MHz, 1915-1920 MHz, 1995-2000 MHz, 2000-2020 MHz, 2110-2155 MHz, 2155-2180 MHz, and 2180-2200 bands, the power of any emission outside a licensee's frequency block shall be attenuated below the transmitter power (P) in watts by at least $43 + 10 \log_{10} (P)$ dB”

Measurement Uncertainty

The assessed measurement uncertainty to ensure 95% confidence level for the normal distribution is with the coverage factor $k = 1.96$, $U=0.684dB$.



Test Result

All the test traces in the plots shows the test results clearly.

NB-IOT Band 4 QPSK 3.75KHz 1@0 CH-Low

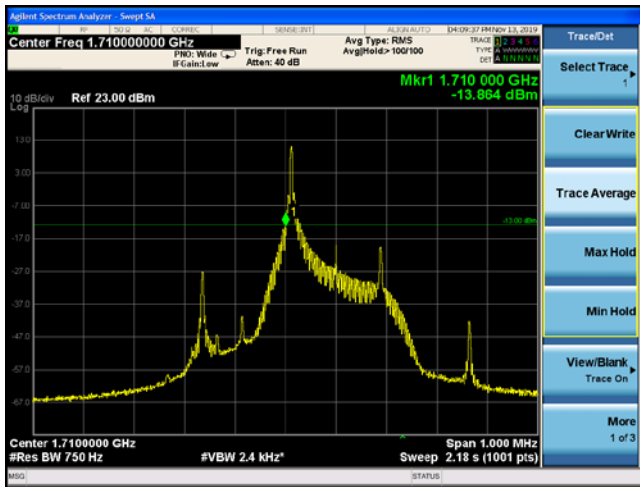

NB-IOT Band 4 QPSK 3.75KHz 1@0 CH-High

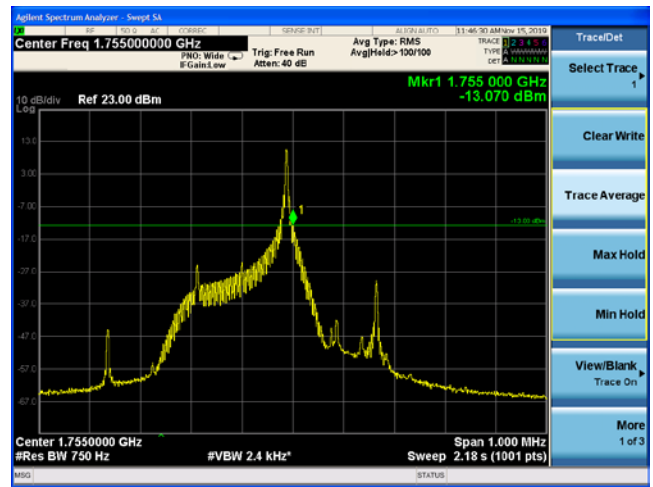

NB-IOT Band 4 QPSK 15KHz 1@0 CH-Low



NB-IOT Band 4 QPSK 15KHz 1@0 CH-High

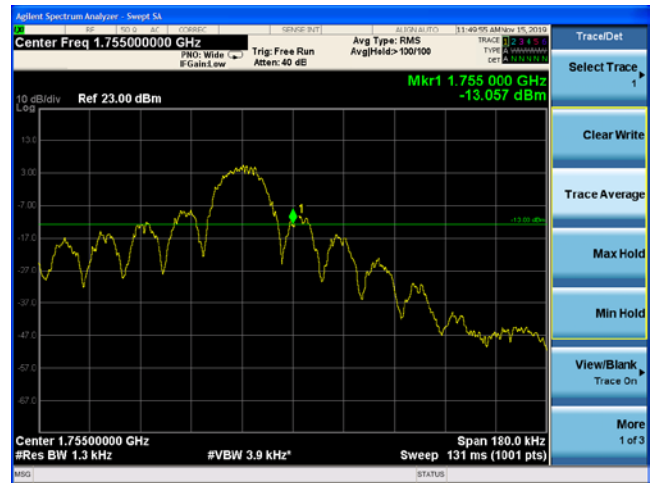

NB-IOT Band 4 QPSK 15KHz 12@0 CH-Low

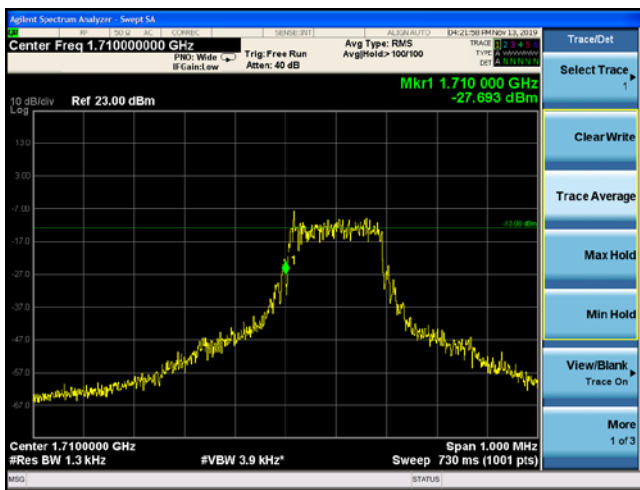

NB-IOT Band 4 QPSK 15KHz 12@0 CH-High

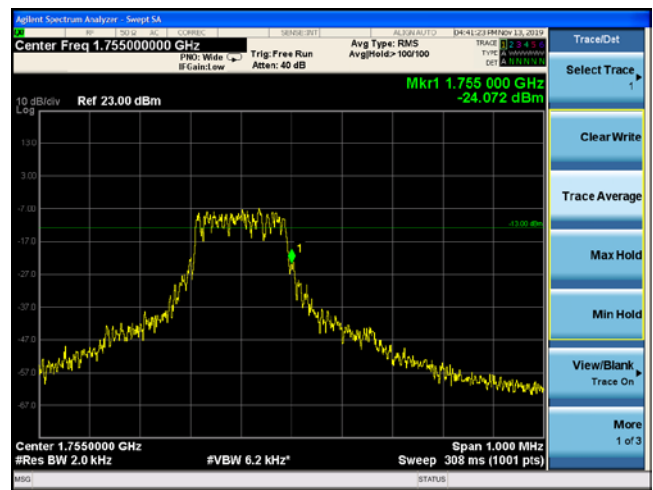



NB-IOT Band 4 BPSK 3.75KHz 1@0 CH-Low

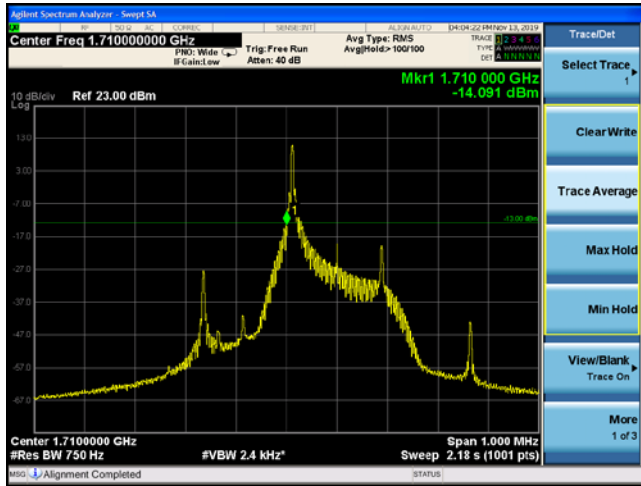

NB-IOT Band 4 BPSK 3.75KHz 1@0 CH-High

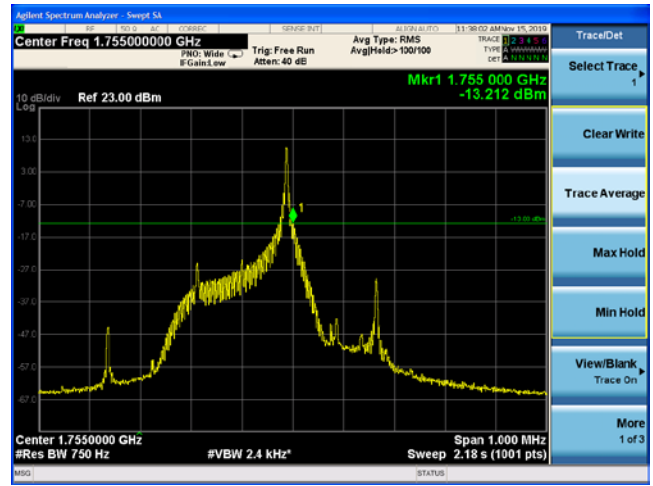

NB-IOT Band 4 BPSK 15KHz 1@0 CH-Low

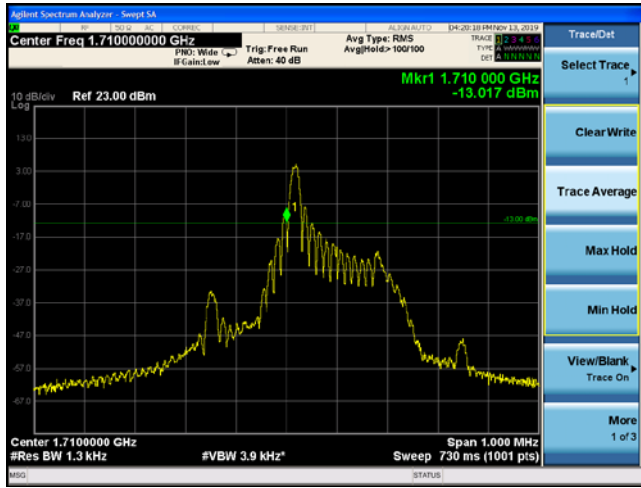

NB-IOT Band 4 BPSK 15KHz 1@0 CH-High



5.4 Peak-to-Average Power Ratio (PAPR)

Ambient condition

Temperature	Relative humidity	Pressure
23°C ~25°C	45%~50%	101.5kPa

Methods of Measurement

Measure the total peak power and record as PPk. And measure the total average power and record as PAvg. Both the peak and average power levels must be expressed in the same logarithmic units (e.g., dBm). Determine the PAPR from:

$$PAPR (dB) = PPk (dBm) - PAvg (dBm).$$

Test Setup

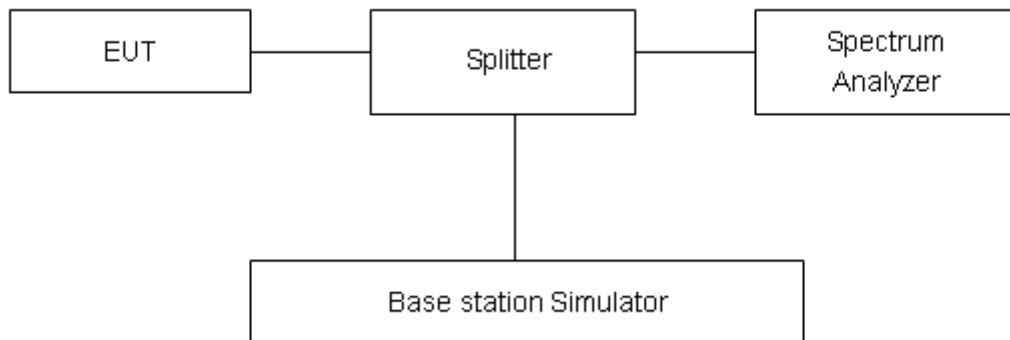

Limits

Rule Part 27.50(d)(5) Equipment employed must be authorized in accordance with the provisions of 24.51. Power measurements for transmissions by stations authorized under this section may be made either in accordance with a Commission-approved average power technique or in compliance with paragraph (d)(6) of this section. In measuring transmissions in this band using an average power technique, the peak-to-average ratio (PAR) of the transmission may not exceed 13 dB.

Measurement Uncertainty

The assessed measurement uncertainty to ensure 95% confidence level for the normal distribution is with the coverage factor $k = 2$, $U = 0.4$ dB.

**Test Results**

NB-IOT Band 4						
Mode	Modulation	Sub-carrier spacing (KHz)	Channel/ Frequency(MHz)	Peak-to-Average Power Ratio (PAPR)		
				Peak(dBm)	Avg(dBm)	PAPR(dB)
Band 4 Standalone	BPSK	3.75	20175/1732.5	22.26	18.32	3.94
	QPSK	3.75	20175/1732.5	21.85	18.41	3.44
	BPSK	15	20175/1732.5	22.17	15.49	6.68
	QPSK	15	20175/1732.5	22.01	15.38	6.63

5.5 Frequency Stability

Ambient condition

Temperature	Relative humidity	Pressure
23°C ~25°C	45%~50%	101.5kPa

Method of Measurement

Frequency Stability (Temperature Variation)

The temperature inside the climate chamber is varied from -40°C to +85°C in 10°C step size.

(1) With all power removed, the temperature was decreased to -10°C and permitted to stabilize for three hours.

(2) Measure the carrier frequency with the test equipment in a “call mode”. These measurements should be made within 1 minute of powering up the mobile station, to prevent significant self warming.

(3) Repeat the above measurements at 10°C increments from -40°C to +85°C. Allow at least 1.5 hours at each temperature, un-powered, before making measurements.

Frequency Stability (Voltage Variation)

The frequency stability shall be measured with variation of primary supply voltage as follows:

(1) Vary primary supply voltage from 85 to 115 percent of the nominal value for other than hand carried battery equipment.

(2) For hand carried, battery powered equipment, reduce primary supply voltage to the battery-operating end point which shall be specified by the manufacturer.

This transceiver is specified to operate with an input voltage of between 6 V and 48 V, with a nominal voltage of 12V.

Test setup

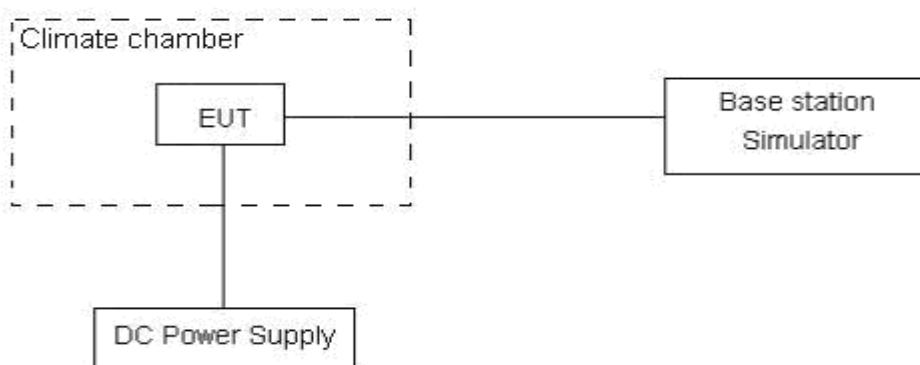

Limits

The frequency stability shall be sufficient to ensure that the fundamental emissions stay within the authorized bands of operation.

Measurement Uncertainty

The assessed measurement uncertainty to ensure 99.75% confidence level for the normal distribution is with the coverage factor $k = 3, U = 0.01\text{ppm}$.



Test Result

NB-IOT Band 4						
Condition		Freq.Error (Hz)	Freq.Error (Hz)	Frequency Stability (ppm)	Frequency Stability (ppm)	Verdict
BANDWIDTH	3.75					
Temperature	Voltage	BPSK	QPSK	BPSK	QPSK	
Normal (25°C)	Normal	9.15	12.51	0.00487	0.00666	PASS
Extreme (85°C)		3.98	4.55	0.00212	0.00242	PASS
Extreme (80°C)		10.12	14.92	0.00538	0.00794	PASS
Extreme (70°C)		11.03	5.78	0.00587	0.00307	PASS
Extreme (60°C)		9.49	12.31	0.00505	0.00655	PASS
Extreme (50°C)		10.23	4.91	0.00544	0.00261	PASS
Extreme (40°C)		6.61	8.89	0.00352	0.00473	PASS
Extreme (30°C)		6.58	9.85	0.00350	0.00524	PASS
Extreme (20°C)		16.83	11.43	0.00895	0.00608	PASS
Extreme (10°C)		10.58	7.97	0.00563	0.00424	PASS
Extreme (0°C)		6.26	9.67	0.00333	0.00514	PASS
Extreme (-10°C)		12.01	7.60	0.00639	0.00404	PASS
Extreme (-20°C)		3.60	15.25	0.00192	0.00811	PASS
Extreme (-30°C)		7.24	17.32	0.00385	0.00921	PASS
Extreme (-40°C)		15.75	10.74	0.00838	0.00571	PASS
25°C	LV	4.51	6.34	0.00240	0.00337	PASS
	HV	14.84	2.16	0.00789	0.00115	PASS

NB-IOT Band 4						
Condition		Freq.Error (Hz)	Freq.Error (Hz)	Frequency Stability (ppm)	Frequency Stability (ppm)	Verdict
BANDWIDTH	15					
Temperature	Voltage	BPSK	QPSK	BPSK	QPSK	
Normal (25°C)	Normal	12.04	2.96	0.00641	0.00157	PASS
Extreme (85°C)		8.90	6.84	0.00473	0.00364	PASS
Extreme (80°C)		11.63	13.64	0.00619	0.00725	PASS
Extreme (70°C)		1.29	3.57	0.00069	0.00190	PASS
Extreme (60°C)		13.97	17.07	0.00743	0.00908	PASS
Extreme (50°C)		1.35	7.65	0.00072	0.00407	PASS
Extreme (40°C)		5.77	4.64	0.00307	0.00247	PASS
Extreme (30°C)		12.82	3.01	0.00682	0.00160	PASS
Extreme (20°C)		2.08	8.19	0.00110	0.00435	PASS
Extreme (10°C)		14.71	8.50	0.00783	0.00452	PASS
Extreme (0°C)		7.99	5.67	0.00425	0.00302	PASS
Extreme (-10°C)		16.15	8.68	0.00859	0.00462	PASS
Extreme (-20°C)		14.33	11.48	0.00762	0.00611	PASS



Extreme (-30°C)		13.95	5.31	0.00742	0.00283	PASS
Extreme (-40°C)		4.73	9.17	0.00251	0.00488	PASS
25°C	LV	17.50	4.66	0.00931	0.00248	PASS
	HV	12.09	16.82	0.00643	0.00895	PASS

5.6 Spurious Emissions at Antenna Terminals

Ambient condition

Temperature	Relative humidity	Pressure
23°C ~25°C	45%~50%	101.5kPa

Method of Measurement

The EUT was connected to Spectrum Analyzer and Base Station Simulator via power Splitter. The measurement is carried out using a spectrum analyzer. The spectrum analyzer scans from 9kHz to the 10th harmonic of the carrier. The peak detector is used.

RBW is set to 100kHz, VBW is set to 300kHz for 30MHz~1GHz

RBW is set to 1MHz, VBW is set to 3MHz for above 1GHz, Sweep is set to ATUO.

Of those disturbances below (limit – 20 dB), the mark is not required for the EUT.

The modulation mode and RB allocation refer to section 5.1, using the maximum output power configuration.

Test setup

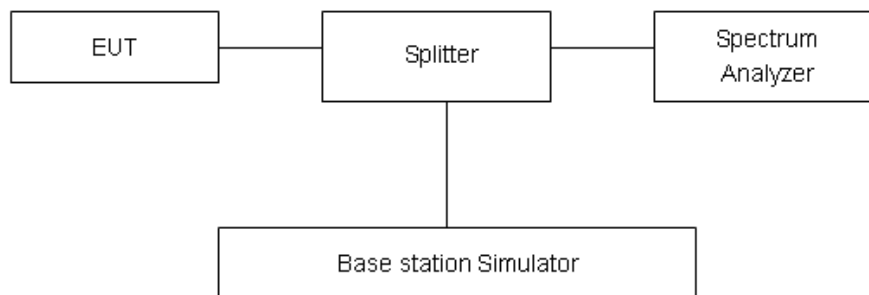

Limits

Rule Part 27.53(h) specifies that “for operations in the 1695-1710 MHz, 1710-1755 MHz, 1755-1780 MHz, 1915-1920 MHz, 1995-2000 MHz, 2000-2020 MHz, 2110-2155 MHz, 2155-2180 MHz, and 2180-2200 bands, the power of any emission outside a licensee's frequency block shall be attenuated below the transmitter power (P) in watts by at least $43 + 10 \log_{10}(P)$ dB..”

Part 27.53(h) Limit	-13 dBm
---------------------	---------

Measurement Uncertainty

The assessed measurement uncertainty to ensure 99.75% confidence level for the normal distribution is with the coverage factor $k = 1.96$.

Frequency	Uncertainty
9kHz-1GHz	0.684 dB
1GHz-27GHz	1.407 dB



Test Result

Sweep the whole frequency band through the range from 9kHz to the 10th harmonic of the carrier, the emissions more than 20 dB below the limit are not reported.

The signal beyond the limit is carrier.

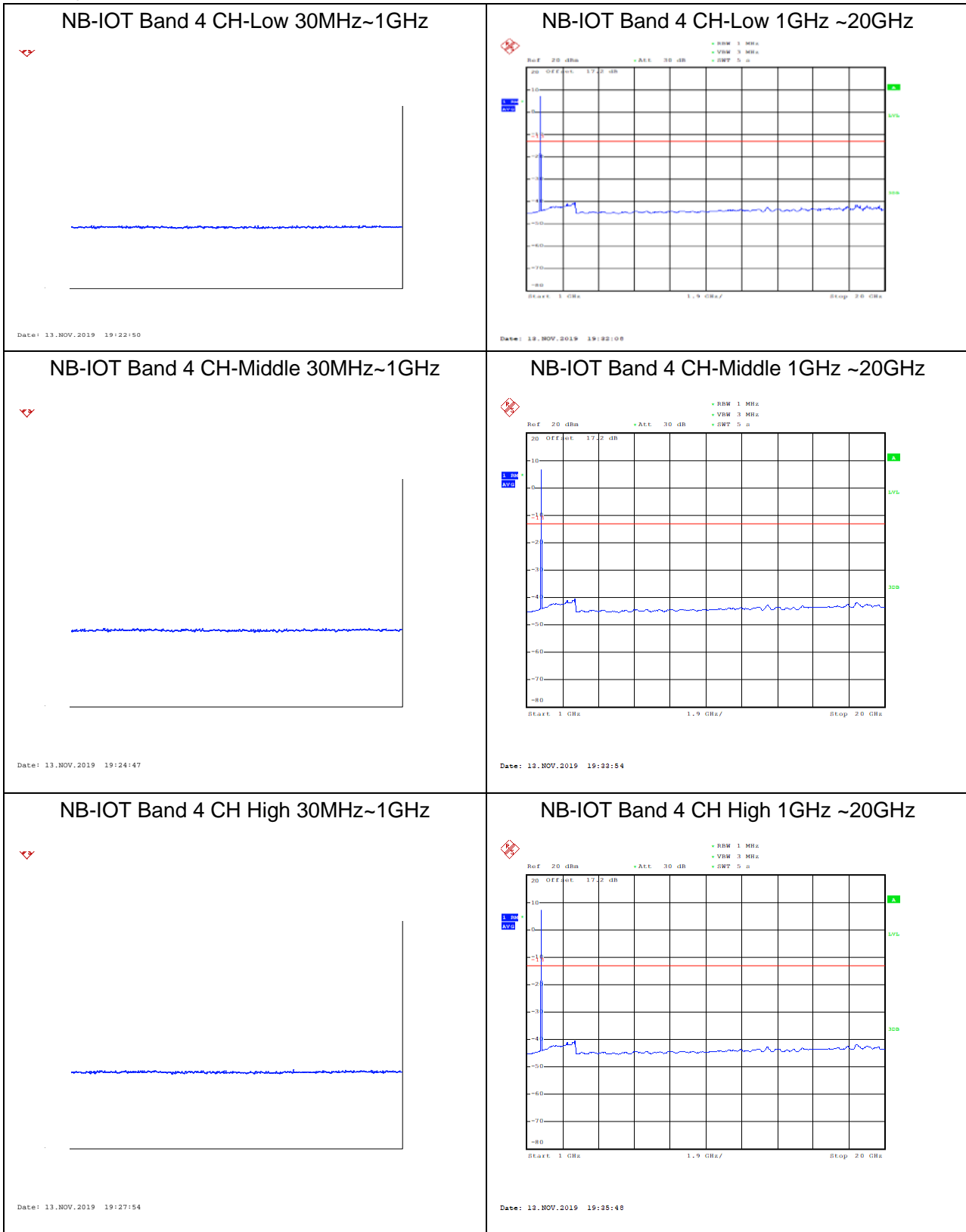

5.7 Radiates Spurious Emission

Ambient condition

Temperature	Relative humidity	Pressure
23°C ~25°C	45%~50%	101.5kPa

Method of Measurement

- The testing follows FCC KDB 971168 D01 v03r01 Section 5.8 and ANSI C63.26 (2015).
- Below 1GHz: The EUT is placed on a turntable 0.8 meters above the ground in the chamber, 3 meter away from the antenna. The maximal emission value is acquired by adjusting the antenna height, polarisation and turntable azimuth. Normally, the height range of antenna is 1 m to 4 m, the azimuth range of turntable is 0° to 360°, and the receive antenna has two polarizations Vertical (V) and Horizontal (H). Above 1GHz: (Note: the FCC's permission to use 1.5m as an alternative per TCBC Conf call of Dec. 2, 2014.) The EUT is placed on a turntable 1.5 meters above the ground in the chamber, 3 meter away from the antenna. The maximal emission value is acquired by adjusting the antenna height, polarisation and turntable azimuth. Normally, the height range of antenna is 1 m to 4 m, the azimuth range of turntable is 0° to 360°, and the receive antenna has two polarizations Vertical (V) and Horizontal (H).
- A loop antenna, A log-periodic antenna or horn antenna shall be substituted in place of the EUT. The log-periodic antenna will be driven by a signal generator and the level will be adjusted till the same power value on the spectrum analyzer or receiver. The level of the spurious emissions can be calculated through the level of the signal generator, cable loss, the gain of the substitution antenna and the reading of the spectrum analyzer or receiver.
- The EUT is then put into continuously transmitting mode at its maximum power level during the test. Set Test Receiver or Spectrum RBW=200Hz,VBW=600Hz for 9kHz150kHz , RBW=10kHz, VBW=30kHz 150kHz-30MHz ,RBW=100kHz,VBW=300kHz for 30MHz to 1GHz and RBW=1MHz, VBW=3MHz for above 1GHz And the maximum value of the receiver should be recorded as (Pr).
- The EUT shall be replaced by a substitution antenna. In the chamber, an substitution antenna for the frequency band of interest is placed at the reference point of the chamber. An RF Signal source for the frequency band of interest is connected to the substitution antenna with a cable that has been constructed to not interfere with the radiation pattern of the antenna. A power (PMea) is applied to the input of the substitution antenna, and adjust the level of the signal generator output until the value of the receiver reach the previously recorded (Pr). The power of signal source (PMea) is recorded. The test should be performed by rotating the test item and adjusting the receiving antenna polarization.
- A amplifier should be connected to the Signal Source output port. And the cable should be connect between the Amplifier and the Substitution Antenna. The cable loss (Pcl) ,the Substitution Antenna Gain (Ga) and the Amplifier Gain (PAg) should be recorded after test.
- The measurement results are obtained as described below:
 $Power(EIRP)=PMea- PAg - Pcl + Ga$
 The measurement results are amend as described below:
 $Power(EIRP)=PMea- Pcl + Ga$
- This value is EIRP since the measurement is calibrated using an antenna of known gain (2.15 dBi) and known input power. ERP can be calculated from EIRP by subtracting the gain of the dipole, ERP

= EIRP-2.15dBi.

The modulation mode and RB allocation refer to section 5.1, using the maximum output power configuration.

Test setup

9KHz ~ 30MHz

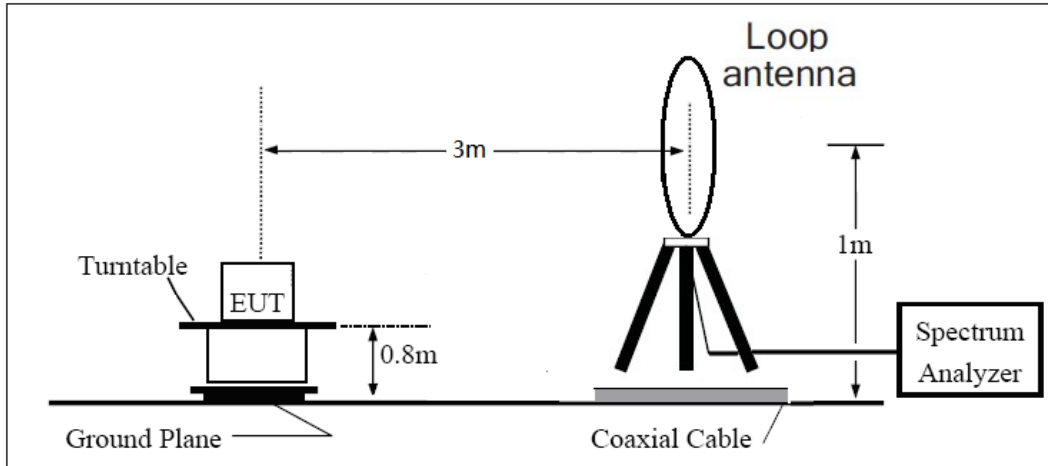

30MHz ~ 1GHz

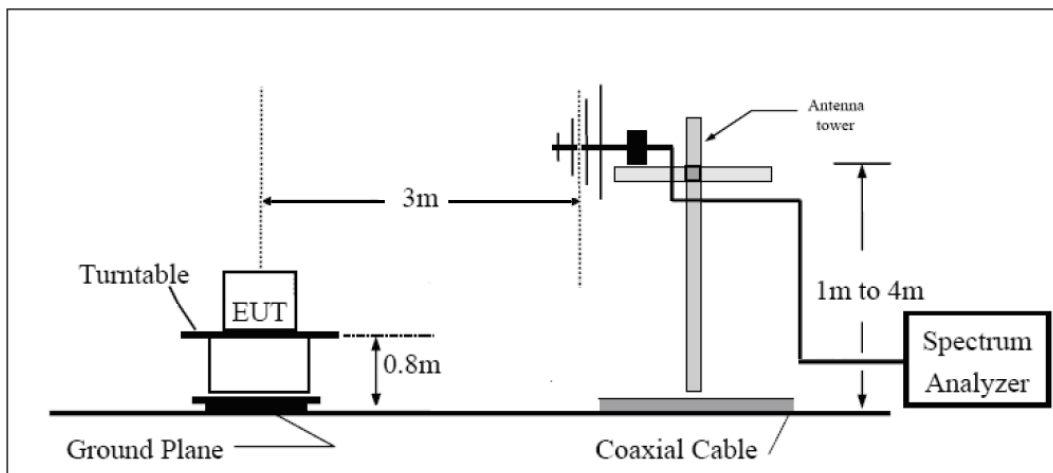

Above 1GHz

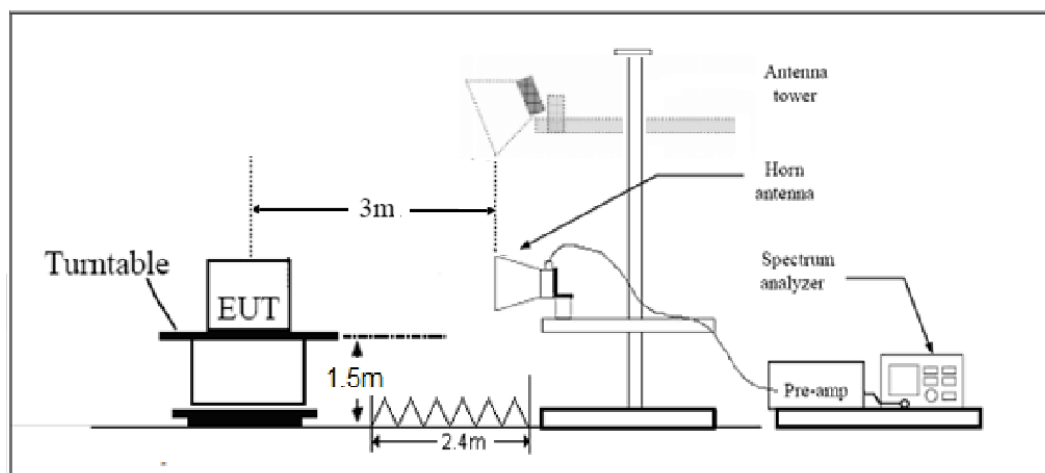

Note: Area side:2.4mX3.6m



Limits

Rule Part 27.53(h) specifies that “for operations in the 1695-1710 MHz, 1710-1755 MHz, 1755-1780 MHz, 1915-1920 MHz, 1995-2000 MHz, 2000-2020 MHz, 2110-2155 MHz, 2155-2180 MHz, and 2180-2200 bands, the power of any emission outside a licensee's frequency block shall be attenuated below the transmitter power (P) in watts by at least $43 + 10 \log_{10} (P)$ dB.”

Part 27.53(h) Limit	-13 dBm
---------------------	---------

Measurement Uncertainty

The assessed measurement uncertainty to ensure 95% confidence level for the normal distribution is with the coverage factor $k = \pm 1.96$, $U = \pm 3.55$ dB.

**Test Result**

Sweep the whole frequency band through the range from 9kHz to the 10th harmonic of the carrier, the emissions below the noise floor will not be recorded in the report.

NB-IOT Band 4 15KHz+QPSK CH-Low

Harmonic	Frequency (MHz)	SG (dBm)	Cable Loss (dB)	Gain (dBi)	Antenna Polarization	EIRP Level (dBm)	Limit (dBm)	Margin (dB)	Azimuth (deg)
2	3465.0	-63.95	2.6	10.15	Horizontal	-56.40	-13.00	43.40	90.0
3	5197.5	-63.81	2.4	11.35	Horizontal	-54.86	-13.00	41.86	315.0
4	6930.0	-58.15	4.5	10.85	Horizontal	-51.80	-13.00	38.80	135.0
5	8662.5	-55.95	5.1	11.35	Horizontal	-49.70	-13.00	36.70	225.0
6	10395.0	-53.95	5.3	11.95	Horizontal	-47.30	-13.00	34.30	270.0
7	12127.5	-54.25	5.5	13.55	Horizontal	-46.20	-13.00	33.20	180.0
8	13860.0	-50.85	6.3	13.75	Horizontal	-43.40	-13.00	30.40	45.0
9	15592.5	-52.75	6.7	13.85	Horizontal	-45.60	-13.00	32.60	135.0
10	17325.0	-48.85	6.8	14.25	Horizontal	-41.40	-13.00	28.40	0.0

Note: 1.The other Spurious RF Radiated emissions level is no more than noise floor.

2. The worst emission was found in the antenna is Horizontal position.

NB-IOT Band 4 15KHz+QPSK CH-Middle

Harmonic	Frequency (MHz)	SG (dBm)	Cable Loss (dB)	Gain (dBi)	Antenna Polarization	EIRP Level (dBm)	Limit (dBm)	Margin (dB)	Azimuth (deg)
2	3420.2	-65.37	2.6	10.75	Horizontal	-57.22	-13.00	44.22	45
3	5130.3	-60.63	2.4	11.05	Horizontal	-51.98	-13.00	38.98	135
4	6840.4	-59.50	4.5	11.15	Horizontal	-52.85	-13.00	39.85	90
5	8550.5	-56.89	5.1	11.35	Horizontal	-50.64	-13.00	37.64	0
6	10260.6	-52.68	5.3	11.95	Horizontal	-46.03	-13.00	33.03	315
7	11970.7	-53.41	5.5	13.55	Horizontal	-45.36	-13.00	32.36	225
8	13680.8	-50.77	6.3	13.75	Horizontal	-43.32	-13.00	30.32	180
9	15390.9	-52.85	6.7	13.85	Horizontal	-45.70	-13.00	32.70	0
10	17101.0	-49.97	6.8	14.25	Horizontal	-42.52	-13.00	29.52	270

Note: 1.The other Spurious RF Radiated emissions level is no more than noise floor.

2. The worst emission was found in the antenna is Horizontal position.



NB-IOT Band 4 15KHz+QPSK CH-High

Harmonic	Frequency (MHz)	SG (dBm)	Cable Loss (dB)	Gain (dBi)	Antenna Polarization	EIRP Level (dBm)	Limit (dBm)	Margin (dB)	Azimuth (deg)
2	3509.8	-63.95	2.6	10.15	Horizontal	-56.40	-13.00	43.40	135
3	5264.7	-64.25	2.4	11.05	Horizontal	-55.60	-13.00	42.60	90
4	7019.6	-56.25	4.5	11.15	Horizontal	-49.60	-13.00	36.60	225
5	8774.5	-55.05	5.1	11.35	Horizontal	-48.80	-13.00	35.80	270
6	10529.4	-52.45	5.3	11.95	Horizontal	-45.80	-13.00	32.80	135
7	12284.3	-54.35	5.5	13.55	Horizontal	-46.30	-13.00	33.30	90
8	14039.2	-50.65	6.3	13.75	Horizontal	-43.20	-13.00	30.20	45
9	15794.1	-52.25	6.7	13.85	Horizontal	-45.10	-13.00	32.10	315
10	17549.0	-50.24	6.8	14.25	Horizontal	-42.79	-13.00	29.79	225

Note: 1.The other Spurious RF Radiated emissions level is no more than noise floor.

2. The worst emission was found in the antenna is Horizontal position.



6 Main Test Instruments

Name	Manufacturer	Type	Serial Number	Calibration Date	Expiration Date
Base Station Simulator	R&S	CMW500	113824	2019-05-19	2020-05-18
Power Splitter	Hua Xiang	SHX-GF2-2-13	10120101	/	/
Spectrum Analyzer	Key sight	N9010A	MY50210259	2019-05-19	2020-05-18
Signal Analyzer	R&S	FSV30	100815	2018-12-16	2019-12-15
Loop Antenna	SCHWARZBECK	FMZB1519	1519-047	2017-09-26	2020-09-25
Trilog Antenna	SCHWARZBECK	VUBL 9163	9163-201	2017-11-18	2020-11-17
Horn Antenna	R&S	HF907	100126	2018-07-07	2020-07-06
Horn Antenna	ETS-Lindgren	3160-09	00102643	2018-06-20	2020-06-19
Signal generator	R&S	SMB 100A	102594	2019-05-19	2020-05-18
Climatic Chamber	ESPEC	SU-242	93000506	2017-12-17	2020-12-16
Preamplifier	R&S	SCU18	102327	2019-05-19	2020-05-18
MOB COMMS DC SUPPLY	Keysight	66319D	MY43004105	2019-05-19	2020-05-18
RF Cable	Agilent	SMA 15cm	0001	2019-06-14	2019-12-13
Software	R&S	EMC32	9.26.0	/	/

*****END OF REPORT *****