



# TEST REPORT

## FCC PART 15.247

Report Reference No. .... : CTL2505095041-WF02

Compiled by: ( position+printed name+signature)	Happy Guo (File administrators)
Tested by: ( position+printed name+signature)	Lynn Tang (Test Engineer)
Approved by: ( position+printed name+signature)	Ivan Xie (Manager)



Product Name ..... : Smart Watch  
 Model/Type reference ..... : P107  
 List Model(s)..... : XSS-SW14  
 Trade Mark..... : N/A  
 FCC ID..... : 2AOM3-P107

Applicant's name ..... : ShenZhen YaWell intelligent Technology Co.,Ltd.  
 Address of applicant ..... : A402, Wuhan University, Shenzhen Research Institute, No. 6  
 Yuexing 2nd Road, Gaoxin District Yuehai Street, Nanshan  
 District, Shenzhen, China

Test Firm..... : Shenzhen CTL Testing Technology Co., Ltd.  
 Address of Test Firm ..... : Floor 1-A, Baisha Technology Park, No.3011, Shahexi Road,  
 Nanshan District, Shenzhen, China 518055

Test specification..... :  
 Standard ..... : FCC Part 15.247: Operation within the bands 902-928 MHz,  
 2400-2483.5 MHz and 5725-5850 MHz.  
 TRF Originator ..... : Shenzhen CTL Testing Technology Co., Ltd.  
 Master TRF..... : Dated 2011-01

Date of receipt of test item ..... : May 27, 2025  
 Date of Test Date..... : May 27, 2025-Jun 27, 2025  
 Date of Issue ..... : Jun 30, 2025  
 Result..... : Pass

**Shenzhen CTL Testing Technology Co., Ltd. All rights reserved.**  
 This publication may be reproduced in whole or in part for non-commercial purposes as long as the Shenzhen CTL Testing Technology Co., Ltd. is acknowledged as copyright owner and source of the material. Shenzhen CTL Testing Technology Co., Ltd. takes no responsibility for and will not assume liability for damages resulting from the reader's interpretation of the reproduced material due to its placement and context.

# TEST REPORT

<b>Test Report No. :</b> CTL2505095041-WF02	Jun 30, 2025
	Date of issue

Equipment under Test : Smart Watch

Sample No : CTL2505095041

Model /Type : P107

Listed Models : XSS-SW14

**Applicant** : **ShenZhen YaWell intelligent Technology Co.,Ltd.**

**Address** : A402, Wuhan University, Shenzhen Research Institute, No. 6  
Yuexing 2nd Road, Gaoxin District Yuehai Street, Nanshan  
District, Shenzhen, China

**Manufacturer** : **ShenZhen YaWell intelligent Technology Co.,Ltd.**

**Address** : A402, Wuhan University, Shenzhen Research Institute, No. 6  
Yuexing 2nd Road, Gaoxin District Yuehai Street, Nanshan  
District, Shenzhen, China

<b>Test result</b>	<b>Pass *</b>
--------------------	---------------

\* In the configuration tested, the EUT complied with the standards specified page 5.

This device (product name: Smart Watch) model name: P107, XSS-SW14 electrical, PCB, BOM are the same, only the model name and appearance color different, which does not affect the test results.

The test results presented in this report relate only to the object tested.

This report shall not be reproduced, except in full, without the written approval of the issuing testing laboratory.



## Table of Contents

Page

<b>1. SUMMARY .....</b>	<b>5</b>
1.1. TEST STANDARDS .....	5
1.2. TEST DESCRIPTION .....	5
1.3. TEST FACILITY .....	6
1.4. AUXILIARY TEST EQUIPMENT INFORMATION .....	6
1.5. STATEMENT OF THE MEASUREMENT UNCERTAINTY .....	6
<b>2. GENERAL INFORMATION .....</b>	<b>8</b>
2.1. ENVIRONMENTAL CONDITIONS .....	8
2.2. GENERAL DESCRIPTION OF EUT .....	8
2.3. DESCRIPTION OF TEST MODES AND TEST FREQUENCY .....	9
2.4. EQUIPMENTS USED DURING THE TEST .....	10
2.5. RELATED SUBMITTAL(S) / GRANT (S) .....	11
2.6. MODIFICATIONS .....	11
<b>3. TEST CONDITIONS AND RESULTS .....</b>	<b>12</b>
3.1. CONDUCTED EMISSIONS TEST .....	12
3.2. RADIATED EMISSIONS AND BAND EDGE .....	15
3.3. MAXIMUM CONDUCTED OUTPUT POWER .....	29
3.4. POWER SPECTRAL DENSITY .....	30
3.5. 6DB BANDWIDTH .....	31
3.6. OUT-OF-BAND EMISSIONS .....	32
3.7. ANTENNA REQUIREMENT .....	33
<b>4. TEST SETUP PHOTOS OF THE EUT .....</b>	<b>34</b>
<b>5. EXTERNAL AND INTERNAL PHOTOS OF THE EUT .....</b>	<b>36</b>

# 1. SUMMARY

## 1.1. TEST STANDARDS

The tests were performed according to following standards:

[FCC Rules Part 15.247](#): Frequency Hopping, Direct Spread Spectrum and Hybrid Systems that are in operation within the bands of 902-928 MHz, 2400-2483.5 MHz, and 5725-5850 MHz

[ANSI C63.10: 2013](#): American National Standard for Testing Unlicensed Wireless Devices

[KDB 558074 D01 15.247 Meas Guidance v05R02](#) : Guidance for Performing Compliance Measurements on Digital Transmission Systems (DTS) Operating Under §15.247

## 1.2. Test Description

FCC PART 15.247		
FCC Part 15.207	AC Power Conducted Emission	PASS
FCC Part 15.247(a)(2)	6dB Bandwidth	PASS
FCC Part 15.247(d)	Spurious RF Conducted Emission	PASS
FCC Part 15.247(b)	Maximum Conducted Output Power	PASS
FCC Part 15.247(e)	Power Spectral Density	PASS
FCC Part 15.109/ 15.205/ 15.209	Radiated Emissions	PASS
FCC Part 15.247(d)	Band Edge	PASS
FCC Part 15.203/15.247 (b)	Antenna Requirement	PASS

Note: N/A= not applicable

### 1.3. Test Facility

#### 1.3.1 Address of the test laboratory

Shenzhen CTL Testing Technology Co., Ltd.

Floor 1-A, Baisha Technology Park, No.3011, Shahexi Road, Nanshan District, Shenzhen, China 518055

There is one 3m semi-anechoic chamber and two line conducted labs for final test. The Test Sites meet the requirements in documents ANSI C63.10 and CISPR 32/EN 55032 requirements.

#### 1.3.2 Laboratory accreditation

The test facility is recognized, certified, or accredited by the following organizations:

##### **CNAS-Lab Code: L7497**

Shenzhen CTL Testing Technology Co., Ltd. has been assessed and proved to be in compliance with CNAS-CL01 Accreditation Criteria for Testing and Calibration Laboratories (identical to ISO/IEC 17025: 2017 General Requirements) for the Competence of Testing and Calibration Laboratories.

##### **A2LA-Lab Cert. No. 4343.01**

Shenzhen CTL Testing Technology Co., Ltd, EMC Laboratory has been accredited by A2LA for technical competence in the field of electrical testing, and proved to be in compliance with ISO/IEC 17025: 2017 General Requirements for the Competence of Testing and Calibration Laboratories and any additional program requirements in the identified field of testing.

##### **IC Registration No.: 9618B**

##### **CAB identifier: CN0041**

The 3m alternate test site of Shenzhen CTL Testing Technology Co., Ltd. EMC Laboratory has been registered by Innovation, Science and Economic Development Canada to test to Canadian radio equipment requirements with Registration No.: 9618B.

##### **FCC-Registration No.: 399832**

##### **Designation No.: CN1216**

Shenzhen CTL Testing Technology Co., Ltd. EMC Laboratory has been registered and fully described in a report filed with the (FCC) Federal Communications Commission. The acceptance letter from the FCC is maintained in our files. Registration 399832.

### 1.4. Auxiliary test equipment information

Manufacturer	Description	Model	Serial Number
Huawei	SuperCharge	HW-100225C00	HC78E2N4121901

### 1.5. Statement of the measurement uncertainty

The data and results referenced in this document are true and accurate. The reader is cautioned that there may be errors within the calibration limits of the equipment and facilities. The measurement uncertainty was calculated for all measurements listed in this test report acc. to CISPR 16 - 4 "Specification for radio disturbance and immunity measuring apparatus and methods – Part 4: Uncertainty in EMC Measurements" and is documented in the Shenzhen CTL Testing Technology Co., Ltd. quality system acc. to DIN EN ISO/IEC 17025. Furthermore, component and process variability of devices similar to that tested may result in additional deviation. The manufacturer has the sole responsibility of continued compliance of the device.

Hereafter the best measurement capability for CTL laboratory is reported:

Test	Measurement	Notes
------	-------------	-------

	<b>Uncertainty</b>	
Transmitter power Radiated	±2.20 dB	(1)
Occupied Bandwidth	±0.02ppm	(1)
Radiated Emission 30~1000MHz	±4.08dB	(1)
Radiated Emission Above 1GHz	±4.32dB	(1)
Conducted Disturbance0.15~30MHz	±2.96dB	(1)
20dB Emission Bandwidth	±1.9%	(1)
Carrier Frequency Separation	±1.9%	(1)
Maximum Power Spectral Density Level	±0.98 dB	(1)
Number of Hopping Channel	±1.9%	(1)
Time of Occupancy	±0.11%	(1)
Max Peak Conducted Output Power	±0.98 dB	(1)
Band-edge Spurious Emission	±1.21dB	(1)
Conducted RF Spurious Emission	9kHz-7GHz:±1.09dB 7GHz-26.5GHz: ±3.27dB	(1)

(1) This uncertainty represents an expanded uncertainty expressed at approximately the 95%

(2) confidence level using a coverage factor of k=1.96.



## 2. GENERAL INFORMATION

### 2.1. Environmental conditions

During the measurement the environmental conditions were within the listed ranges:

Normal Temperature:	25°C
Relative Humidity:	55 %
Air Pressure:	101 kPa

### 2.2. General Description of EUT

Product Name:	Smart Watch
Model/Type reference:	P107
Power supply:	DC 3.8V form battery or charging by AC-DC adapter
Test Voltage:	DC 3.8V
<b>Bluetooth Low Energy</b>	
Supported type:	Bluetooth Low Energy
Modulation:	GFSK
Operation frequency:	2402MHz~2480MHz
Channel number:	40
Channel separation:	2MHz
Antenna type:	Built-in antenna
Antenna gain:	0.17 dBi

Note1: For more details, please refer to the user's manual of the EUT.

Note2: Antenna gain provided by the applicant.



### 2.3. Description of Test Modes and Test Frequency

The Applicant provides communication tools software to control the EUT for staying in continuous transmitting (Duty Cycle more than 98%) and receiving mode for testing.

There are 40 channels provided to the EUT and Channel 00/19/39 were selected for BLE test.

#### Operation Frequency List :

Channel	Frequency (MHz)
<b>00</b>	<b>2402</b>
02	2404
03	2406
:	:
<b>19</b>	<b>2440</b>
:	:
37	2476
38	2478
<b>39</b>	<b>2480</b>

Note: The line display in grey were the channel selected for testing

## 2.4. Equipments Used during the Test

Test Equipment	Manufacturer	Model No.	Serial No.	Last Cal.	Cal.Due
EMI Test Receiver	ROHDE & SCHWARZ	ESCI	1166.5950.03	2025/04/29	2026/04/28
LISN	ROHDE & SCHWARZ	ESH2-Z5	860014/010	2025/04/29	2026/04/28
Limitator	ROHDE & SCHWARZ	ESH3-Z2	100408	2025/04/29	2026/04/28
Software:					
Name of Software:			Version:		
ES-K1			V1.71		

Test Equipment	Manufacturer	Model No.	Serial No.	Last Cal.	Cal.Due
Ring antenna	Da Ze	ZN30900A	/	2024/04/30	2027/04/29
Double cone logarithmic antenna	Schwarzbeck	VULB 9168	824	2023/02/13	2026/02/12
Horn Antenna	Sunol Sciences Corp.	DRH-118	A062013	2024/11/25	2027/11/24
Horn Antenna	Ocean Microwave	OBH100400	26999002	2025/02/21	2028/02/20
Amplifier	/	XSD-LNA-1-18G-45A	/	2025/04/30	2026/04/29
Amplifier	Agilent	8449B	3008A02306	2025/05/01	2026/04/30
Amplifier	Brief&Smart	LNA-4018	2104197	2025/04/30	2026/04/29
EMI Test Receiver	ROHDE & SCHWARZ	ESCI	1166.5950.03	2025/04/29	2026/04/28
Spectrum Analyzer	RS	FSP	1164.4391.38	2025/04/29	2026/04/28
9kHz-40GHz coaxial line chamber 2	/	Z108-NJ-NJ-9.5M	21121049	2024/12/01	2025/11/30
Software:					
Name of Software:			Version:		
EZ_EMG(Below 1GHz)			V1.1.4.2		
EZ_EMG(Above 1GHz)			V1.1.4.2		

Test Equipment	Manufacturer	Model No.	Serial No.	Last Cal.	Cal.Due
Spectrum Analyzer	Keysight	N9020A	MY53420874	2025/04/29	2026/04/28
Temperature/Humidity Meter	Ji Yu	MC501	/	2025/05/06	2026/05/05
Software:					
Name of Software:			Version:		
TST-PASS			V2.0		

## **2.5. Related Submittal(s) / Grant (s)**

This submittal(s) (test report) is intended to comply with Section 15.247 of the FCC Part 15, Subpart C Rules.

## **2.6. Modifications**

No modifications were implemented to meet testing criteria.

### 3. TEST CONDITIONS AND RESULTS

#### 3.1. Conducted Emissions Test

##### LIMIT

FCC CFR Title 47 Part 15 Subpart C Section 15.207

Frequency range (MHz)	Limit (dBuV)	
	Quasi-peak	Average
0.15-0.5	66 to 56*	56 to 46*
0.5-5	56	46
5-30	60	50

\* Decreases with the logarithm of the frequency.

##### TEST CONFIGURATION

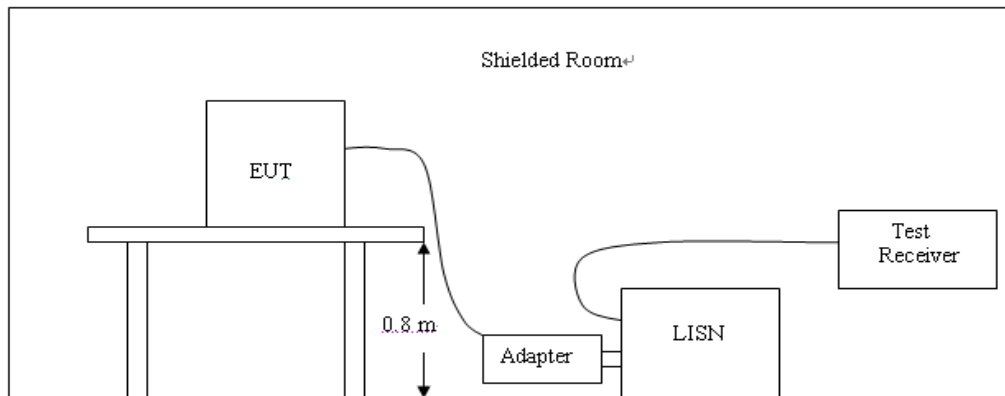

##### TEST PROCEDURE

1. The equipment was set up as per the test configuration to simulate typical actual usage per the user's manual. The EUT is a Smart Watchop system; a wooden table with a height of 0.8 meters is used and is placed on the ground plane as per ANSI C63.10:2013.
2. Support equipment, if needed, was placed as per ANSI C63.10:2013.
3. All I/O cables were positioned to simulate typical actual usage as per ANSI C63.10:2013.
4. The adapter received AC120V/60Hz power through a Line Impedance Stabilization Network (LISN) which supplied power source and was grounded to the ground plane.
5. All support equipments received AC power from a second LISN, if any.
6. The EUT test program was started. Emissions were measured on each current carrying line of the EUT using a spectrum Analyzer / Receiver connected to the LISN powering the EUT. The LISN has two monitoring points: Line 1 (Hot Side) and Line 2 (Neutral Side). Two scans were taken: one with Line 1 connected to Analyzer / Receiver and Line 2 connected to a 50 ohm load; the second scan had Line 1 connected to a 50 ohm load and Line 2 connected to the Analyzer / Receiver.
7. Analyzer / Receiver scanned from 150 KHz to 30MHz for emissions in each of the test modes.
8. During the above scans, the emissions were maximized by cable manipulation.

**TEST RESULTS**

Remark:

1. All low, middle and high channel were tested; only the worst result of low channel was reported as below:

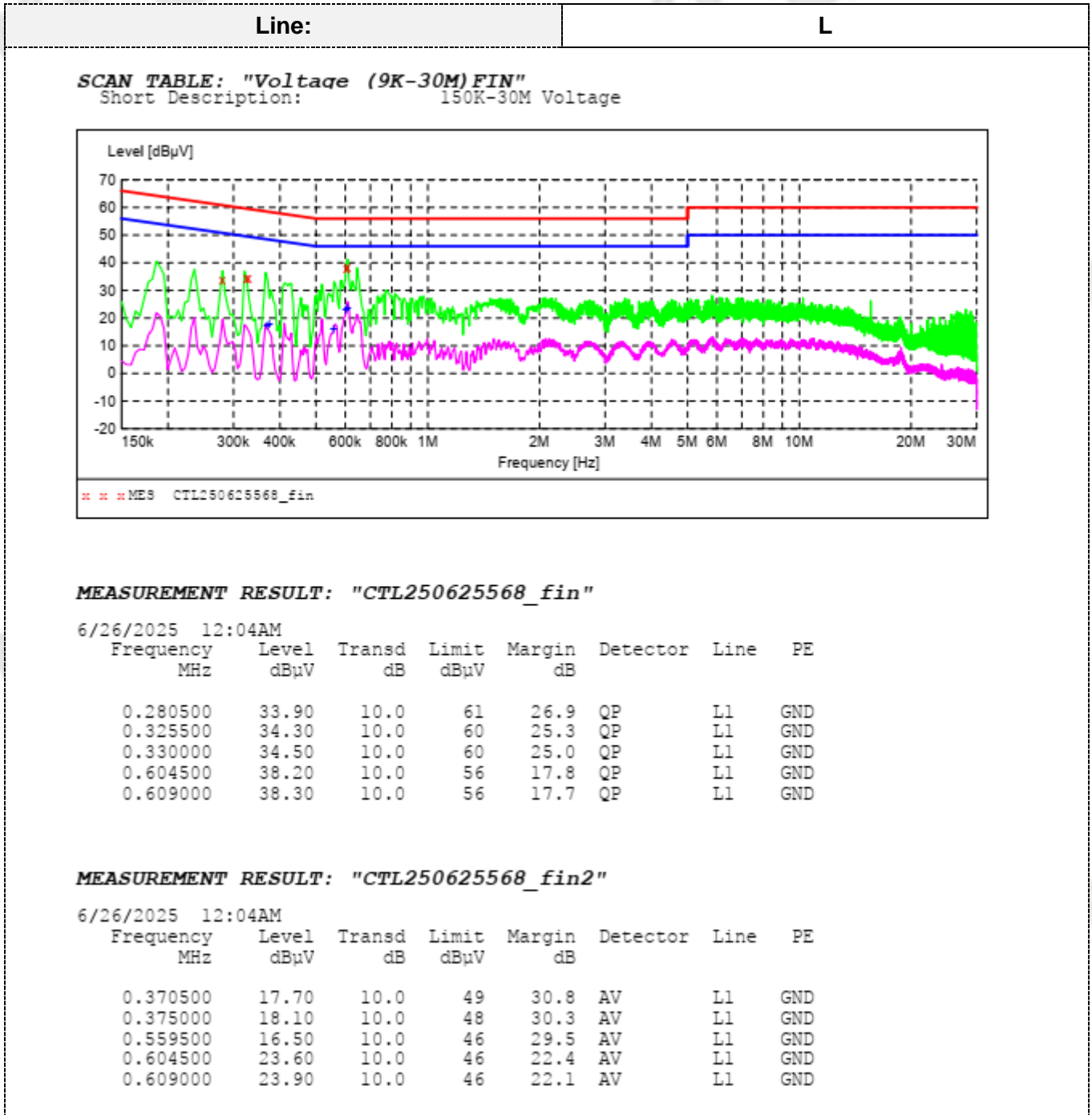

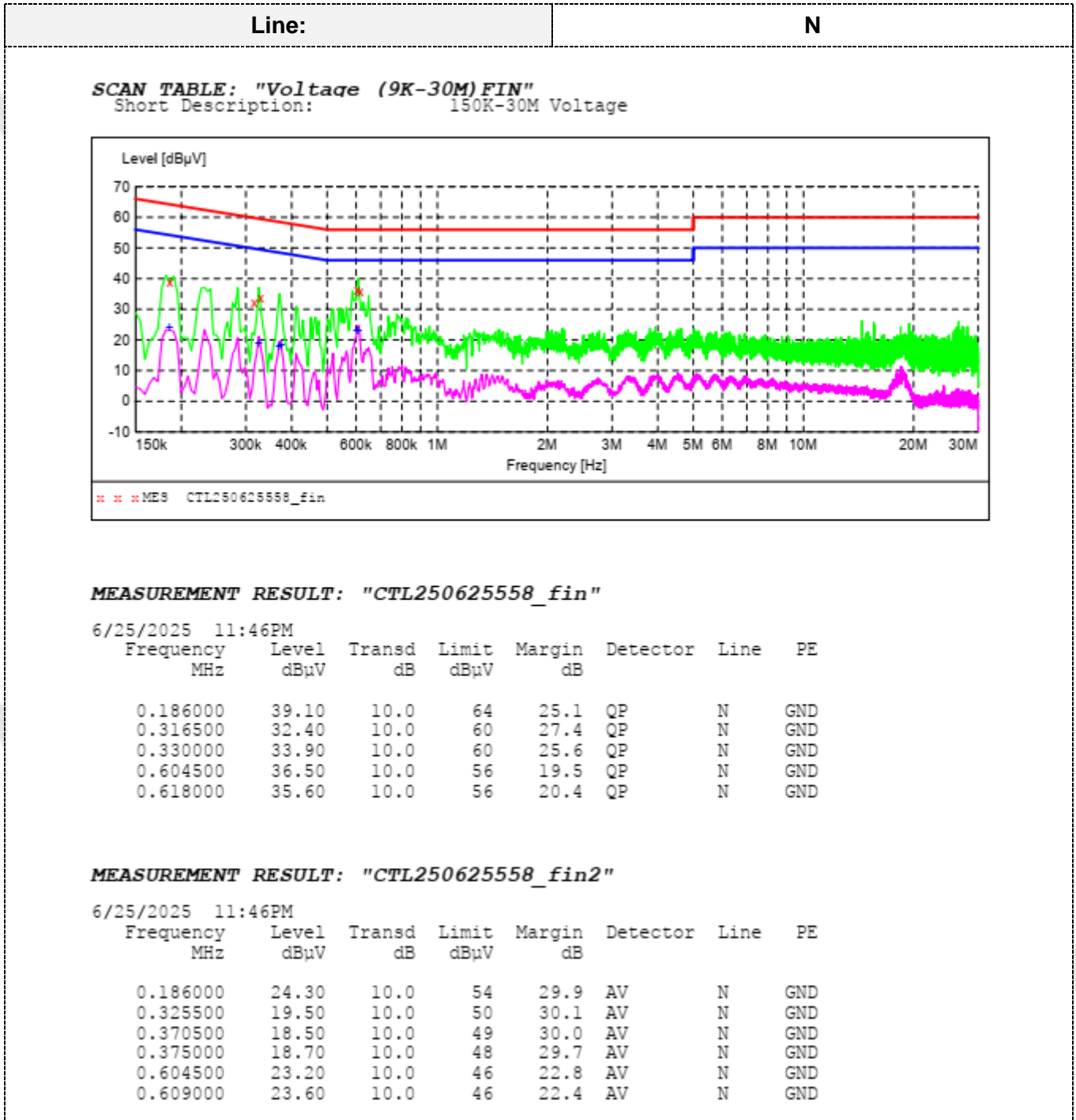

### 3.2. Radiated Emissions and Band Edge

#### Limit

For intentional device, according to § 15.209(a), the general requirement of field strength of radiated emission out of authorized band shall not exceed the following table at a 3 meters measurement distance.

In addition, radiated emissions which fall in the restricted bands, as defined in §15.205(a), must also comply with the radiated emission limits specified in §15.209(a)

Radiated emission limits

Frequency (MHz)	Distance (Meters)	Radiated (dBµV/m)	Radiated (µV/m)
0.009-0.49	3	$20\log(2400/F(\text{KHz}))+40\log(300/3)$	$2400/F(\text{KHz})$
0.49-1.705	3	$20\log(24000/F(\text{KHz}))+40\log(30/3)$	$24000/F(\text{KHz})$
1.705-30	3	$20\log(30)+40\log(30/3)$	30
30-88	3	40.0	100
88-216	3	43.5	150
216-960	3	46.0	200
Above 960	3	54.0	500

#### TEST CONFIGURATION

(A) Radiated Emission Test Set-Up, Frequency Below 30MHz

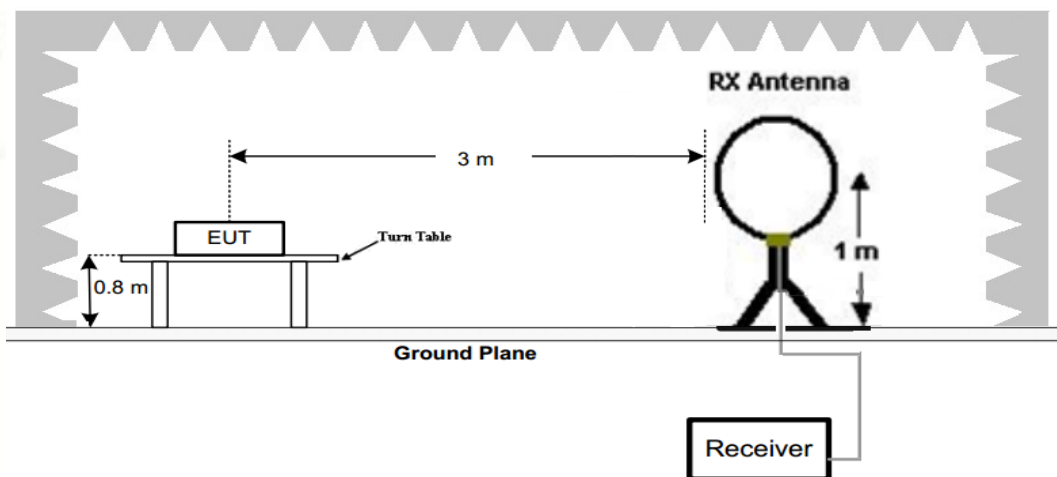

(B) Radiated Emission Test Set-Up, Frequency below 1000MHz

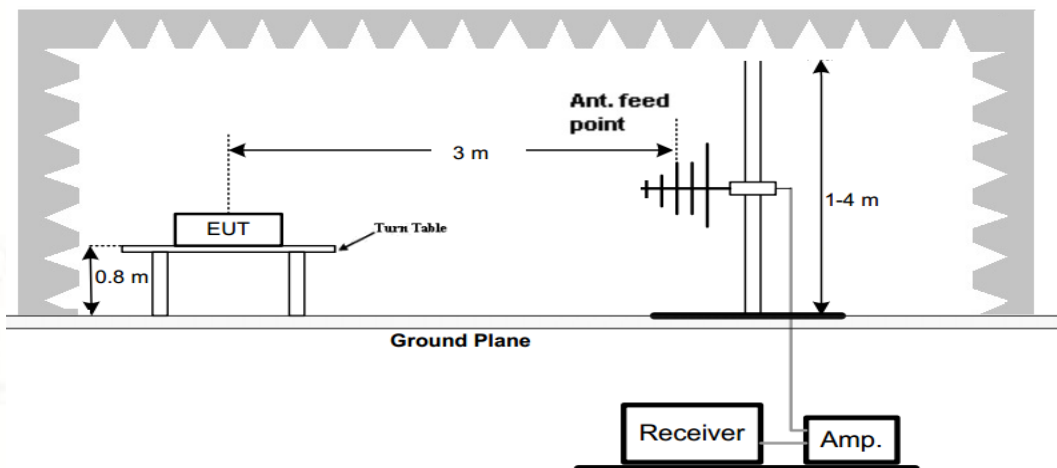

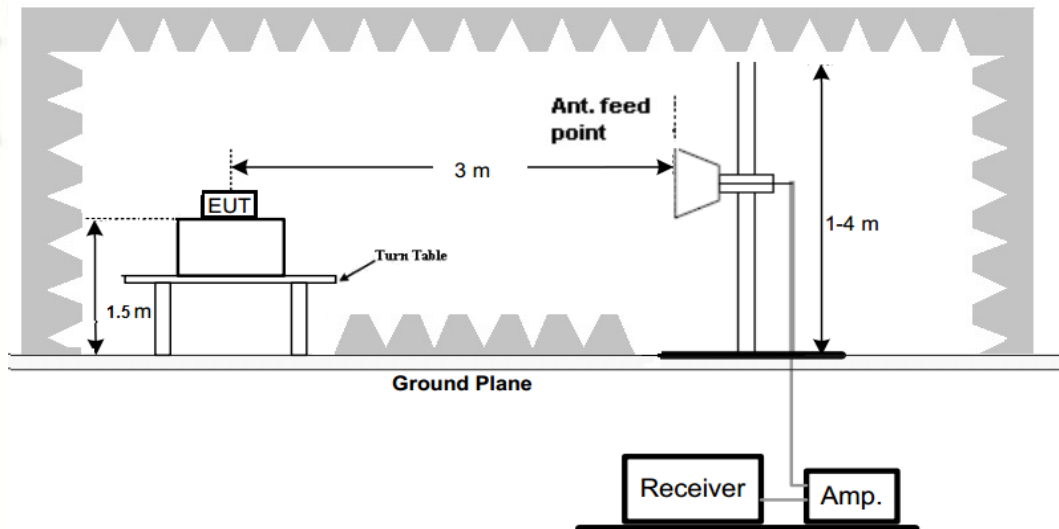

## (C) Radiated Emission Test Set-Up, Frequency above 1000MHz

**Test Procedure**

1. Below 1GHz measurement the EUT is placed on a turntable which is 0.8m above ground plane, and above 1GHz measurement EUT was placed on a low permittivity and low loss tangent turn table which is 1.5m above ground plane.
2. Maximum procedure was performed by raising the receiving antenna from 1m to 4m and rotating the turn table from 0°C to 360°C to acquire the highest emissions from EUT
3. And also, each emission was to be maximized by changing the polarization of receiving antenna both horizontal and vertical.
4. Repeat above procedures until all frequency measurements have been completed.
5. The EUT was pretested with 3 orientations placed on the table for the radiated emission
6. measurement –X, Y, and Z-plane. The X-plane results were found as the worst case and were
7. shown in this report

**TEST RESULTS**

## Remark:

1. We have tested low channel, middle channel, high channel, only recorded worst at low channel.
2. Radiated emission test from 9 KHz to 10th harmonic of fundamental was verified, Found the emission level are attenuated 20dB below the limits from 9 kHz to 30MHz, so it does not recorded in report.

For 30MHz-1GHz

Horizontal



Shenzhen CTL Testing Technology Co., Ltd  
Tel: +86-755-89486194

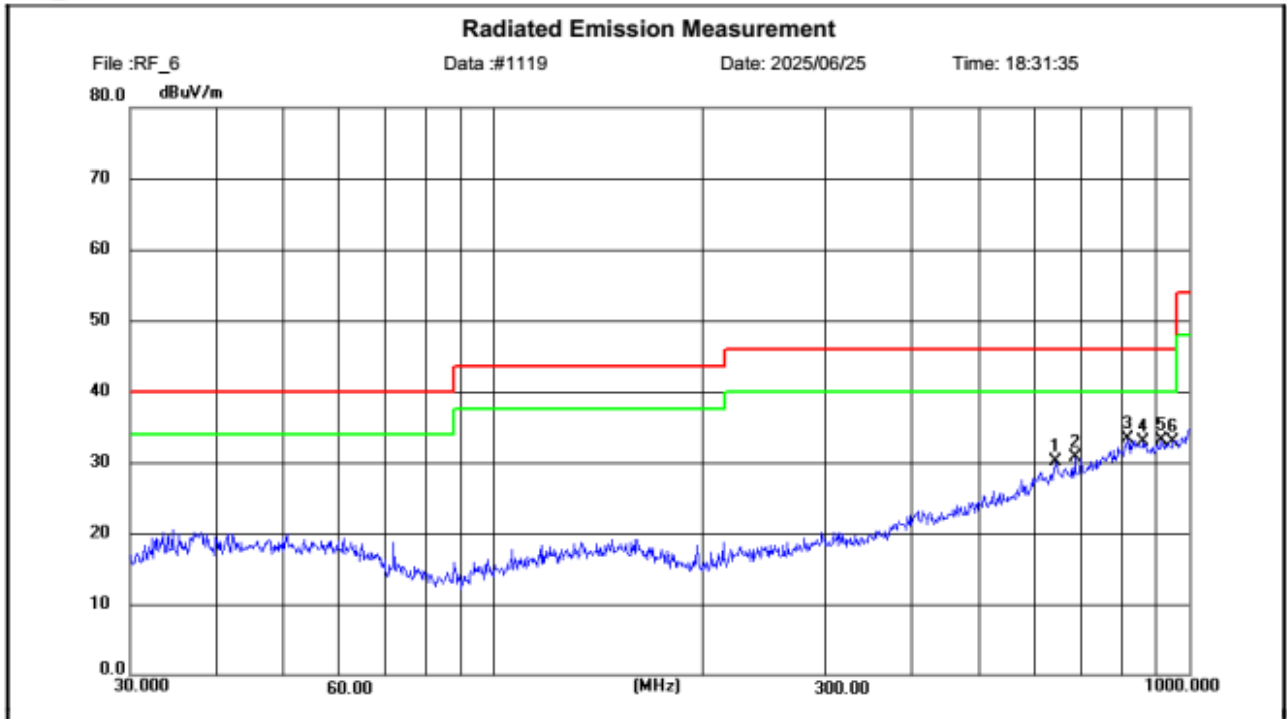

Site LAB Chamber 2      Polarization: *Horizontal*      Temperature: 25(C)  
Limit: FCC Part15 RE-Class C\_30-1000MHz      Power:      Humidity: 50 %  
EUT:      Distance: 3m  
M/N:  
Mode: BLE1M 2402MHz  
Note: CTL2505095041-WF

No.	Frequency (MHz)	Reading (dBuV)	Factor (dB/m)	Level (dBuV/m)	Limit (dBuV/m)	Margin (dB)	Detector	Height (cm)	Azimuth (deg.)	P/F	Remark
1	643.1431	7.36	22.67	30.03	46.00	15.97	peak	100	327	P	
2	686.2476	7.94	22.74	30.68	46.00	15.32	peak	100	54	P	
3	817.3996	7.39	25.97	33.36	46.00	12.64	peak	100	340	P	
4	861.5443	6.44	26.38	32.82	46.00	13.18	peak	100	355	P	
5	915.6672	6.27	26.75	33.02	46.00	12.98	peak	100	212	P	
6	949.1770	5.77	27.11	32.88	46.00	13.12	peak	100	155	P	

Vertical



Shenzhen CTL Testing Technology Co., Ltd  
Tel: +86-755-89486194

Radiated Emission Measurement

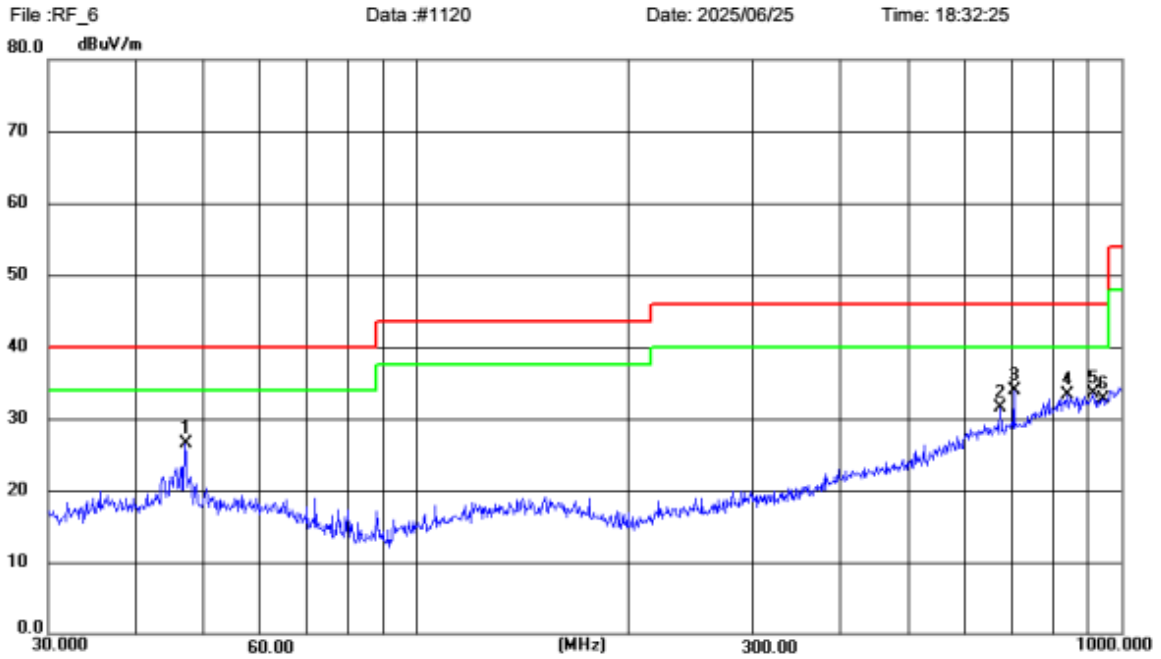

Site LAB Chamber 2      Polarization: *Vertical*      Temperature: 25(C)  
 Limit: FCC Part15 RE-Class C\_30-1000MHz      Power:      Humidity: 50 %  
 EUT:      Distance: 3m  
 M/N:  
 Mode: BLE1M 2402MHz  
 Note: CTL2505095041-WF

No.	Frequency (MHz)	Reading (dBuV)	Factor (dB/m)	Level (dBuV/m)	Limit (dBuV/m)	Margin (dB)	Detector	Height (cm)	Azimuth (deg.)	P/F	Remark
1	46.9948	12.06	14.38	26.44	40.00	13.56	peak	100	278	P	
2	673.1395	8.87	22.61	31.48	46.00	14.52	peak	100	206	P	
3	704.8437	11.24	22.67	33.91	46.00	12.09	peak	100	108	P	
4	841.3917	7.02	26.21	33.23	46.00	12.77	peak	100	263	P	
5	913.2623	6.84	26.71	33.55	46.00	12.45	peak	100	163	P	
6	944.1975	5.63	27.10	32.73	46.00	13.27	peak	100	278	P	

For 1GHz to 18GHz

BLE Mode (above 1GHz)

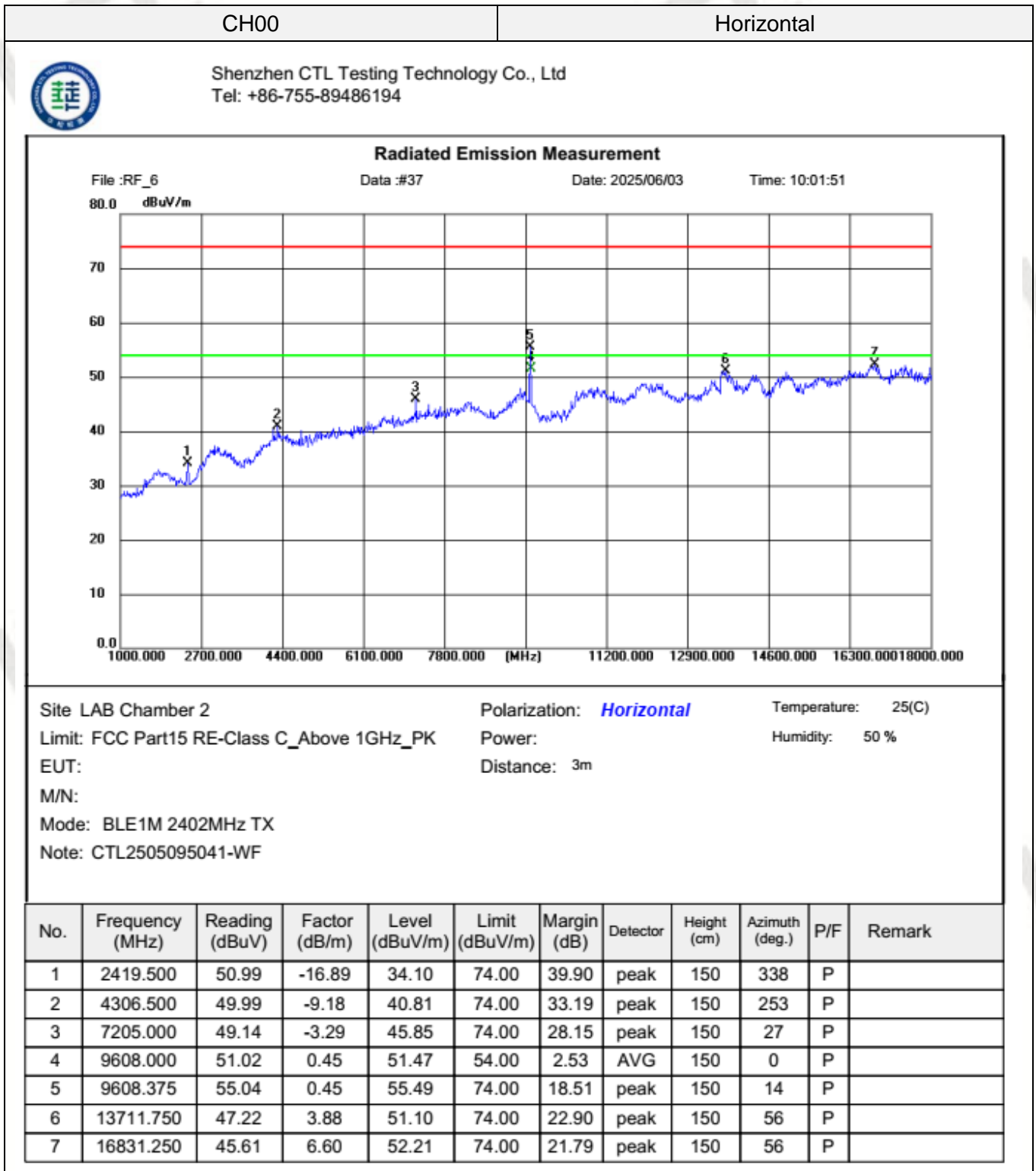

CH00

Vertical



Shenzhen CTL Testing Technology Co., Ltd  
Tel: +86-755-89486194

**Radiated Emission Measurement**

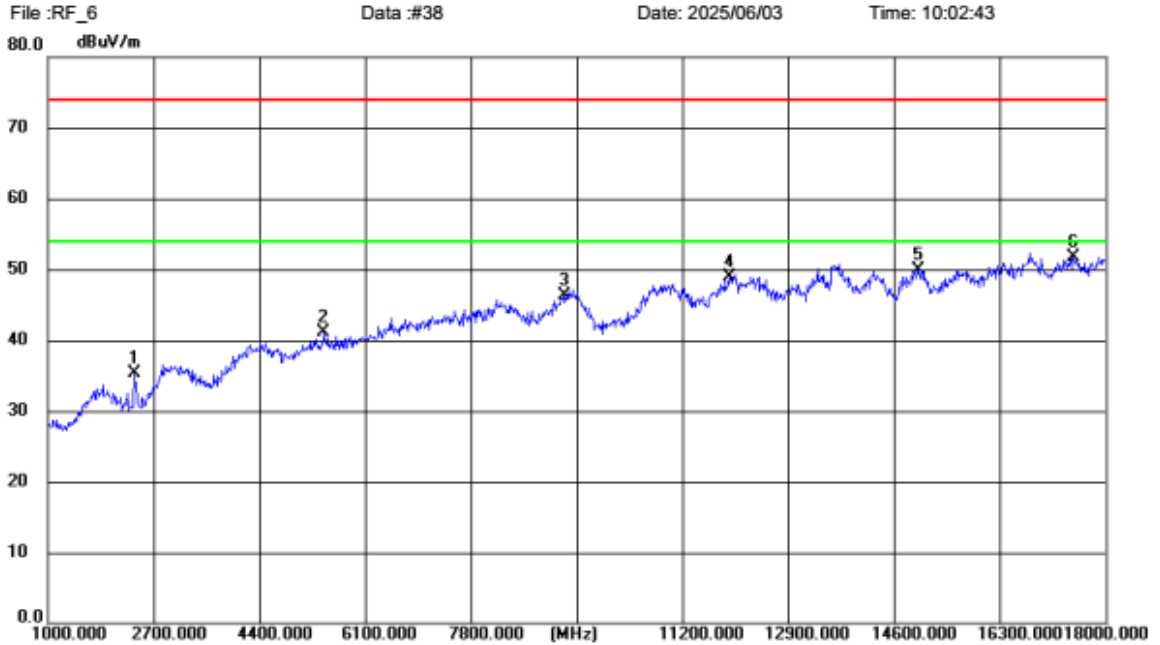

Site LAB Chamber 2      Polarization: **Vertical**      Temperature: 25(C)  
 Limit: FCC Part15 RE-Class C\_Above 1GHz\_PK      Power:      Humidity: 50 %  
 EUT:      Distance: 3m  
 M/N:  
 Mode: BLE1M 2402MHz TX  
 Note: CTL2505095041-WF

No.	Frequency (MHz)	Reading (dBuV)	Factor (dB/m)	Level (dBuV/m)	Limit (dBuV/m)	Margin (dB)	Detector	Height (cm)	Azimuth (deg.)	P/F	Remark
1	2400.375	52.25	-16.92	35.33	74.00	38.67	peak	150	222	P	
2	5443.375	48.98	-7.81	41.17	74.00	32.83	peak	150	222	P	
3	9304.500	46.11	0.11	46.22	74.00	27.78	peak	150	222	P	
4	11960.750	46.85	2.07	48.92	74.00	25.08	peak	150	222	P	
5	14999.500	46.58	3.34	49.92	74.00	24.08	peak	150	222	P	
6	17496.375	42.55	9.15	51.70	74.00	22.30	peak	150	222	P	

CH19

Horizontal



Shenzhen CTL Testing Technology Co., Ltd  
Tel: +86-755-89486194

**Radiated Emission Measurement**

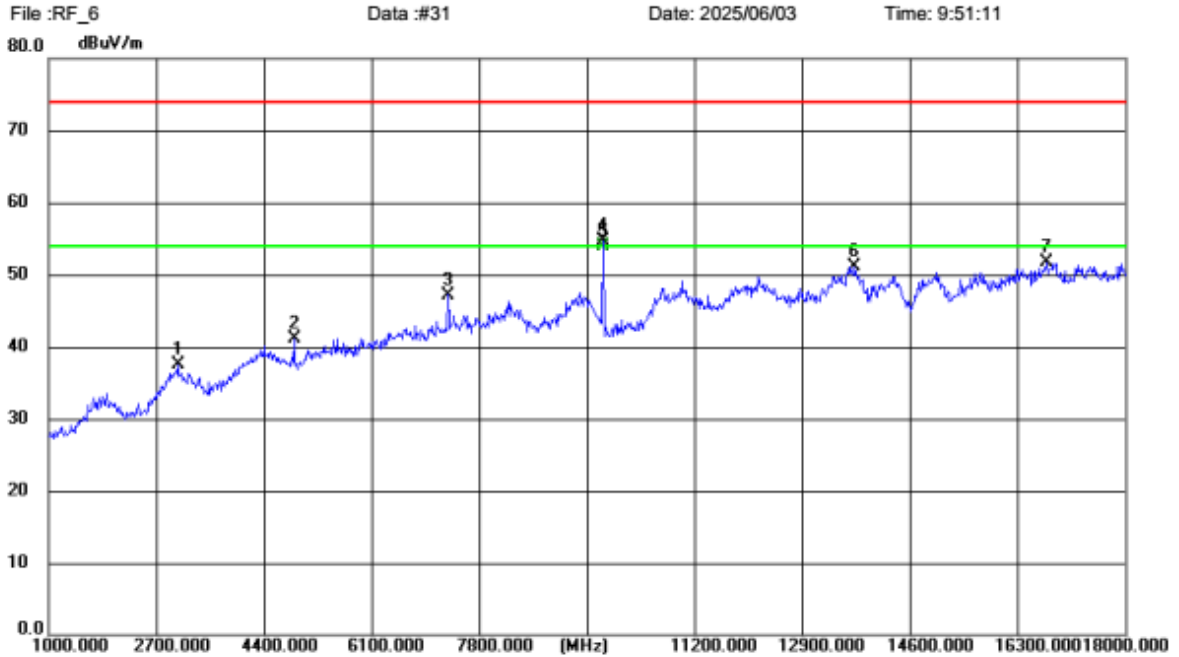

Site LAB Chamber 2      Polarization: *Horizontal*      Temperature: 25(C)  
 Limit: FCC Part15 RE-Class C\_Above 1GHz\_PK      Power:      Humidity: 50 %  
 EUT:      Distance: 3m  
 M/N:  
 Mode: BLE1M 2440MHz TX  
 Note: CTL2505095041-WF

No.	Frequency (MHz)	Reading (dBuV)	Factor (dB/m)	Level (dBuV/m)	Limit (dBuV/m)	Margin (dB)	Detector	Height (cm)	Azimuth (deg.)	P/F	Remark
1	3040.000	51.43	-13.84	37.59	74.00	36.41	peak	150	309	P	
2	4880.250	49.07	-7.96	41.11	74.00	32.89	peak	150	239	P	
3	7319.750	50.18	-2.98	47.20	74.00	26.80	peak	150	14	P	
4	9759.250	54.15	0.51	54.66	74.00	19.34	peak	150	14	P	
5	9759.980	53.36	0.51	53.87	54.00	0.13	AVG	150	0	P	
6	13747.875	47.34	3.81	51.15	74.00	22.85	peak	150	1	P	
7	16773.875	45.10	6.55	51.65	74.00	22.35	peak	150	140	P	

CH19

Vertical



Shenzhen CTL Testing Technology Co., Ltd  
Tel: +86-755-89486194

**Radiated Emission Measurement**

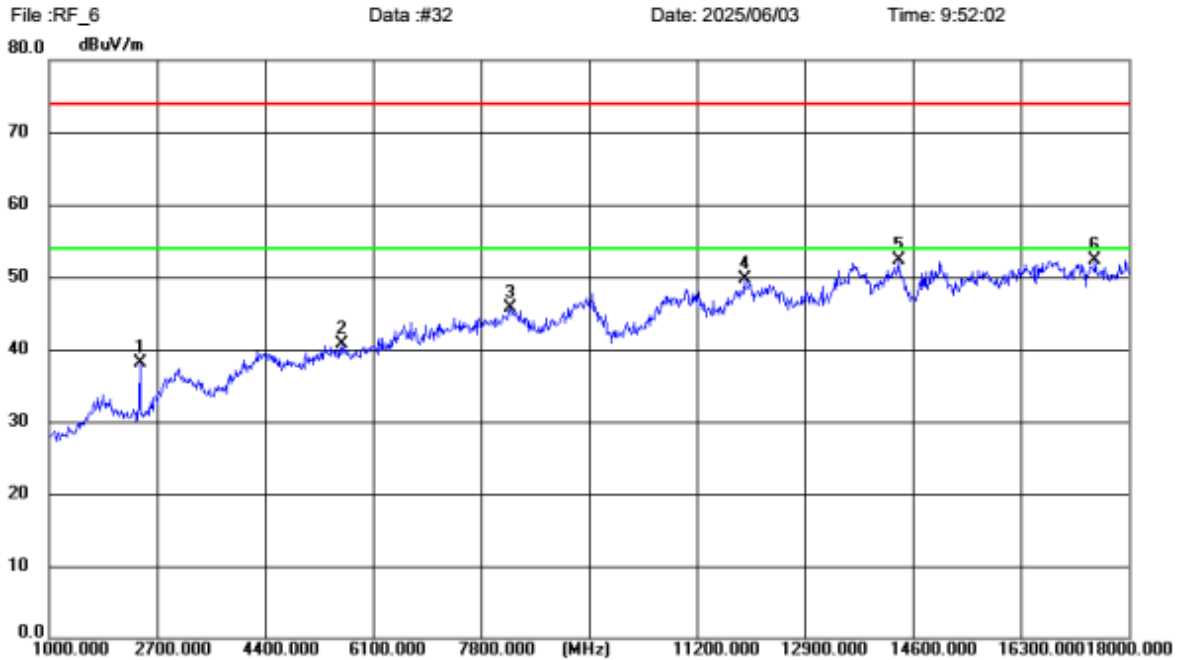

Site LAB Chamber 2      Polarization: **Vertical**      Temperature: 25(C)  
 Limit: FCC Part15 RE-Class C\_Above 1GHz\_PK      Power:      Humidity: 50 %  
 EUT:      Distance: 3m  
 M/N:  
 Mode: BLE1M 2440MHz TX  
 Note: CTL2505095041-WF

No.	Frequency (MHz)	Reading (dBuV)	Factor (dB/m)	Level (dBuV/m)	Limit (dBuV/m)	Margin (dB)	Detector	Height (cm)	Azimuth (deg.)	P/F	Remark
1	2438.625	54.97	-16.85	38.12	74.00	35.88	peak	150	261	P	
2	5613.375	47.92	-7.24	40.68	74.00	33.32	peak	150	35	P	
3	8259.000	48.06	-2.28	45.78	74.00	28.22	peak	150	191	P	
4	11962.875	47.54	2.08	49.62	74.00	24.38	peak	150	275	P	
5	14381.125	49.54	2.67	52.21	74.00	21.79	peak	150	204	P	
6	17479.375	43.26	9.07	52.33	74.00	21.67	peak	150	134	P	



CH39

Horizontal



Shenzhen CTL Testing Technology Co., Ltd  
Tel: +86-755-89486194

**Radiated Emission Measurement**

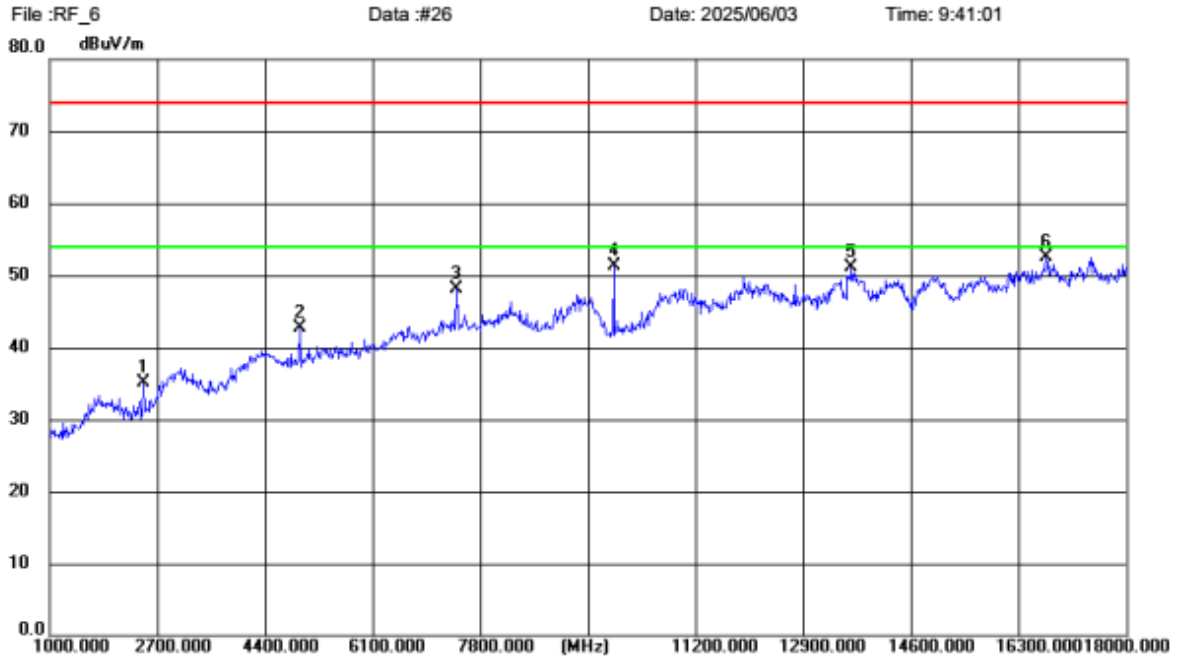

Site LAB Chamber 2      Polarization: *Horizontal*      Temperature: 25(C)  
 Limit: FCC Part15 RE-Class C\_Above 1GHz\_PK      Power:      Humidity: 50 %  
 EUT:      Distance: 3m  
 M/N:  
 Mode: BLE1M 2480MHz TX  
 Note: CTL2505095041-WF

No.	Frequency (MHz)	Reading (dBuV)	Factor (dB/m)	Level (dBuV/m)	Limit (dBuV/m)	Margin (dB)	Detector	Height (cm)	Azimuth (deg.)	P/F	Remark
1	2479.000	51.81	-16.65	35.16	74.00	38.84	peak	150	184	P	
2	4958.875	50.64	-7.85	42.79	74.00	31.21	peak	150	268	P	
3	7440.875	51.01	-2.81	48.20	74.00	25.80	peak	150	28	P	
4	9920.750	50.62	0.61	51.23	74.00	22.77	peak	150	1	P	
5	13675.625	47.28	3.91	51.19	74.00	22.81	peak	150	360	P	
6	16756.875	46.00	6.53	52.53	74.00	21.47	peak	150	70	P	

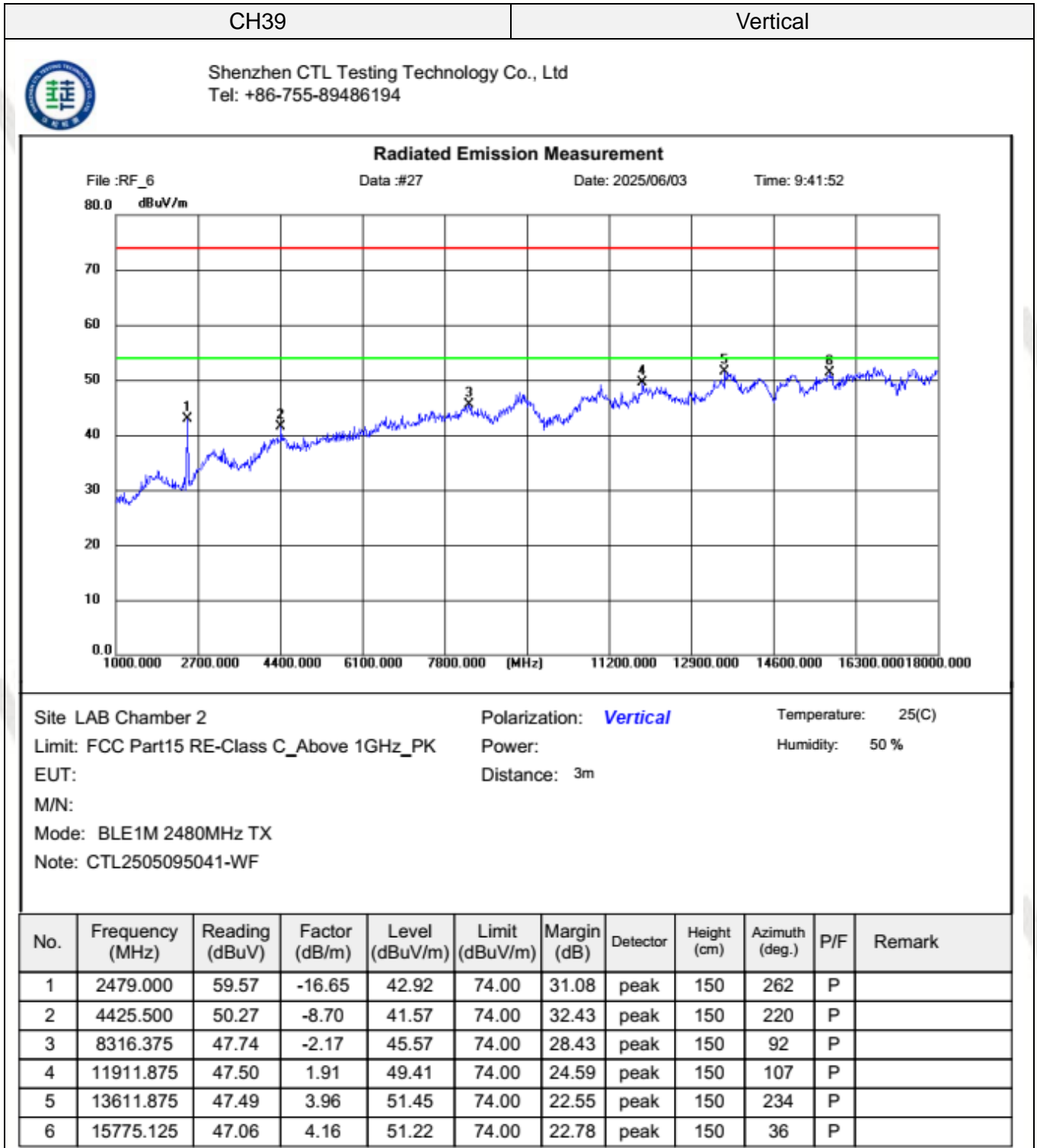

REMARKS:

1. Emission level (dBuV/m) =Raw Value (dBuV)+Correction Factor (dB/m)
2. Correction Factor (dB/m) = Antenna Factor (dB/m)+Cable Factor (dB)-Pre-amplifier Factor
3. Margin value = Limit value- Emission level.
4. RBW1MHz VBW3MHz Peak detector is for PK value; RBW 1MHz VBW10Hz Peak detector is for AV value.
5. Other emissions are attenuated 20dB below the limits from 9kHz to 30MHz, so it does not recorded in report.
6. 18GHz-26GHz not recorded for no spurious point have a margin of less than 6 dB with respect to the limits.

**Results of Band Edges Test (Radiated)**

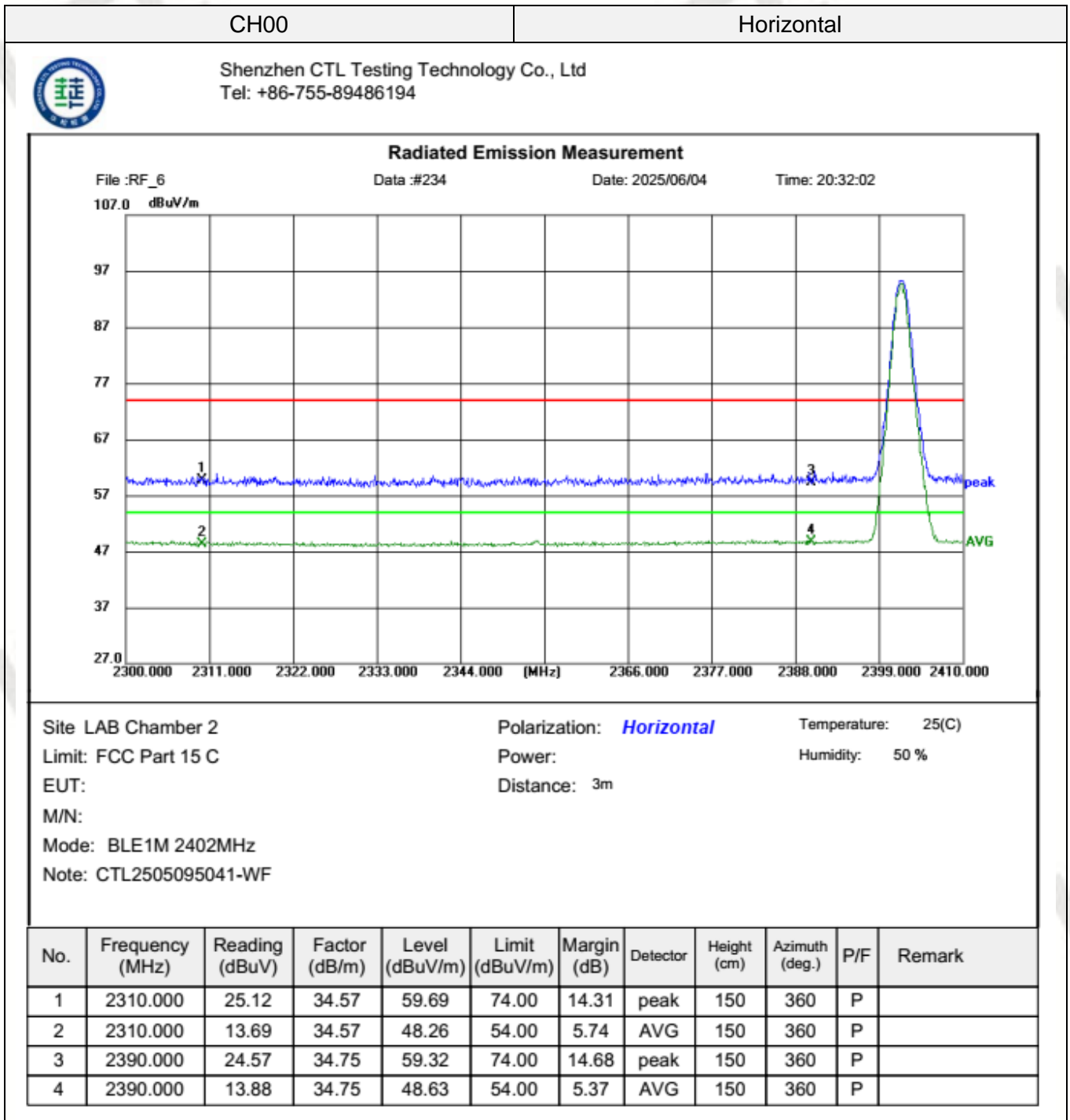

CH00

Vertical



Shenzhen CTL Testing Technology Co., Ltd  
Tel: +86-755-89486194

**Radiated Emission Measurement**

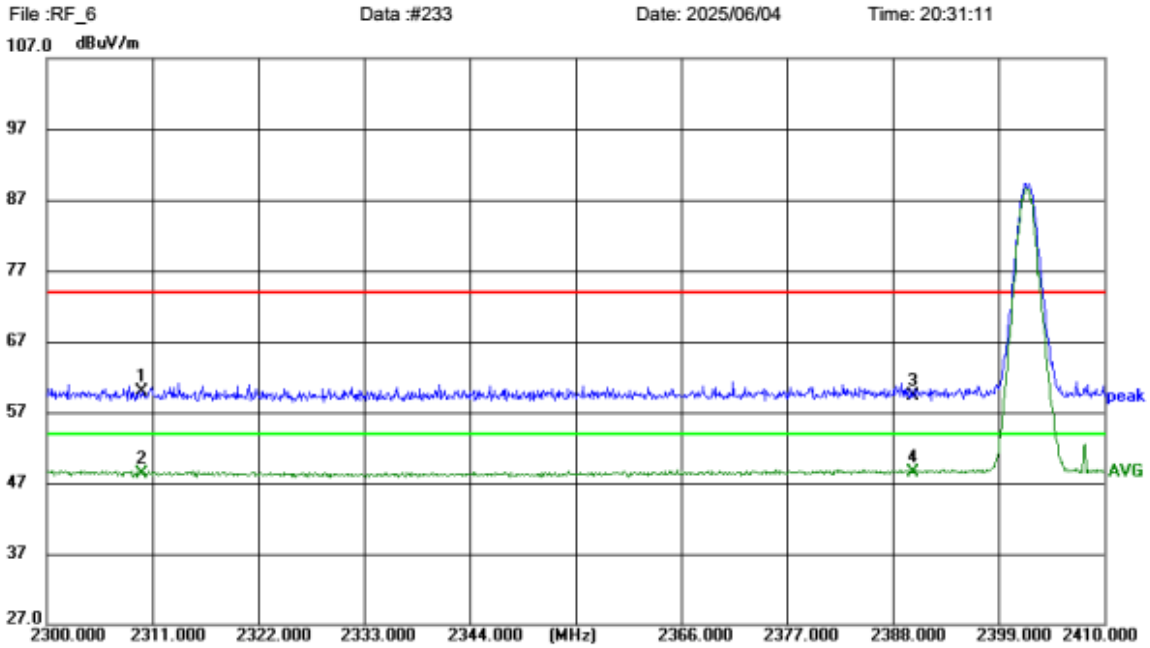

Site LAB Chamber 2      Polarization: **Vertical**      Temperature: 25(C)  
 Limit: FCC Part 15 C      Power:      Humidity: 50 %  
 EUT:      Distance: 3m  
 M/N:  
 Mode: BLE1M 2402MHz  
 Note: CTL2505095041-WF

No.	Frequency (MHz)	Reading (dBuV)	Factor (dB/m)	Level (dBuV/m)	Limit (dBuV/m)	Margin (dB)	Detector	Height (cm)	Azimuth (deg.)	P/F	Remark
1	2310.000	25.43	34.57	60.00	74.00	14.00	peak	150	0	P	
2	2310.000	13.77	34.57	48.34	54.00	5.66	AVG	150	0	P	
3	2390.000	24.59	34.75	59.34	74.00	14.66	peak	150	0	P	
4	2390.000	13.73	34.75	48.48	54.00	5.52	AVG	150	0	P	

CH39

Horizontal



Shenzhen CTL Testing Technology Co., Ltd  
Tel: +86-755-89486194

**Radiated Emission Measurement**

File :RF\_6      Data :#201      Date: 2025/06/04      Time: 19:44:57

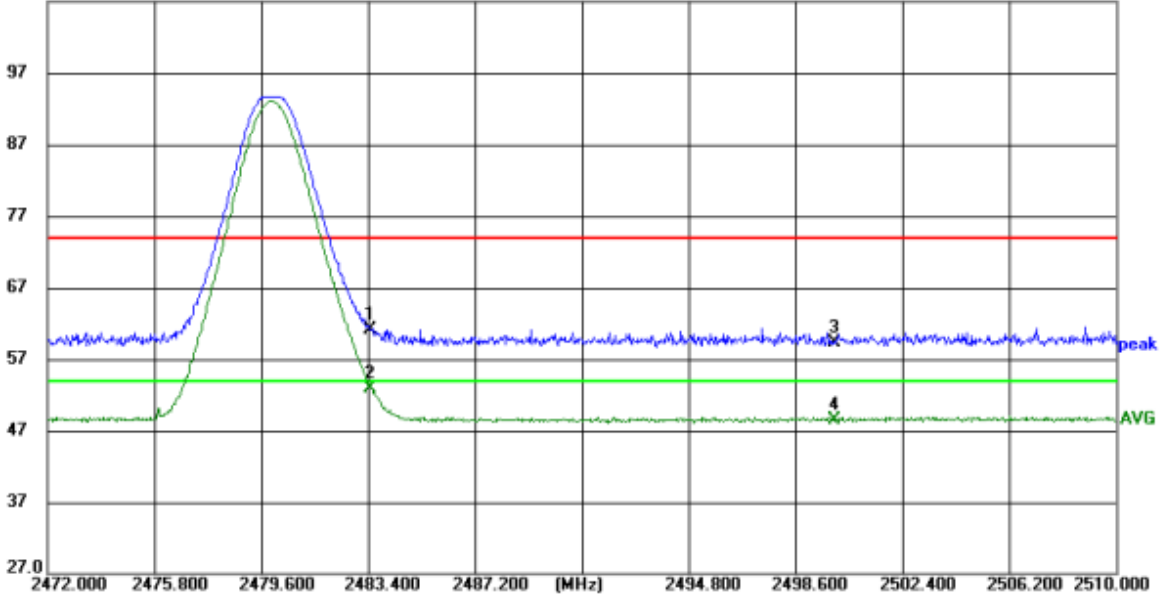

Site LAB Chamber 2  
Limit: FCC Part 15 C  
EUT:  
M/N:  
Mode: BLE1M 2480MHz  
Note: CTL2505095041-WF

Polarization: *Horizontal*  
Power:  
Distance: 3m

Temperature: 25(C)  
Humidity: 50 %

No.	Frequency (MHz)	Reading (dBuV)	Factor (dB/m)	Level (dBuV/m)	Limit (dBuV/m)	Margin (dB)	Detector	Height (cm)	Azimuth (deg.)	P/F	Remark
1	2483.500	26.07	35.03	61.10	74.00	12.90	peak	150	360	P	
2	2483.500	17.93	35.03	52.96	54.00	1.04	AVG	150	360	P	
3	2500.000	24.19	35.12	59.31	74.00	14.69	peak	150	360	P	
4	2500.000	13.39	35.12	48.51	54.00	5.49	AVG	150	360	P	

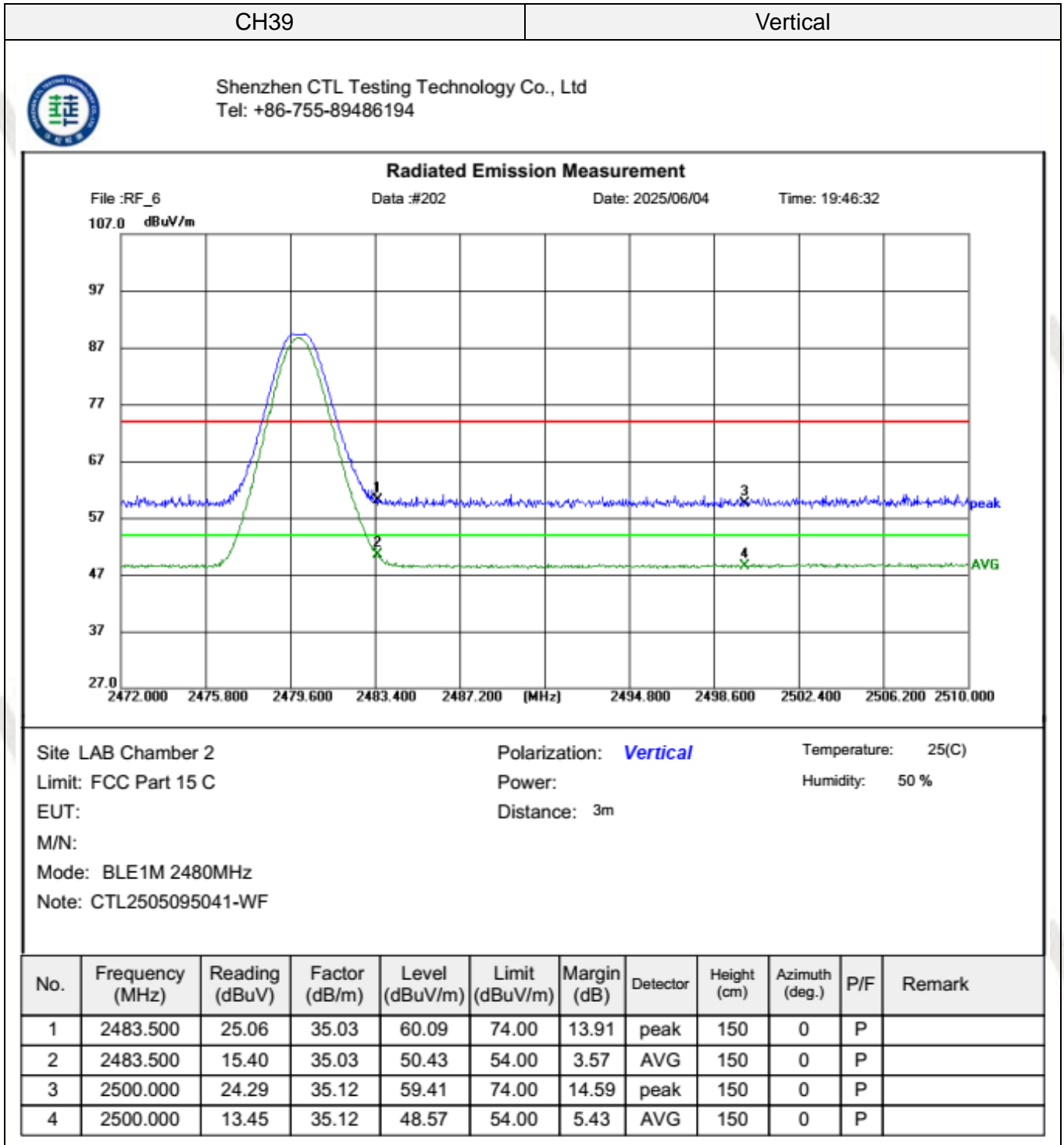

REMARKS:

1. Emission level (dBuV/m) =Raw Value (dBuV)+Correction Factor (dB/m)
2. Correction Factor (dB/m) = Antenna Factor (dB/m)+Cable Factor (dB)-Pre-amplifier Factor
3. Margin value = Limit value- Emission level.
4. RBW1MHz VBW3MHz Peak detector is for PK value; RBW 1MHz VBW10Hz Peak detector is for AV value.
5. For fundamental frequency, RBW 3MHz VBW 3MHz Peak detector is for PK Value; RMS detector is for AV value.
6. Other emissions are attenuated 20dB below the limits from 9kHz to 30MHz, so it does not recorded in report.

### 3.3. Maximum Conducted Output Power

#### Limit

The Maximum Peak Output Power Measurement is 30dBm.

#### Test Procedure

Remove the antenna from the EUT and then connect a low loss RF cable from the antenna port to the spectrum.

#### Test Configuration



#### Test Results

Raw data reference to Appendix Test Data for Bluetooth LE Section 2.



### 3.4. Power Spectral Density

#### Limit

For digitally modulated systems, the power spectral density conducted from the intentional radiator to the antenna shall not be greater than 8 dBm in any 3 kHz band during any time interval of continuous transmission.

#### Test Procedure

1. Use this procedure when the maximum peak conducted output power in the fundamental emission is used to demonstrate compliance.
2. Set the RBW  $\geq$  3 kHz.
3. Set the VBW  $\geq$  3 $\times$  RBW.
4. Set the span to 1.5 times the DTS channel bandwidth.
5. Detector = peak.
6. Sweep time = auto couple.
7. Trace mode = max hold.
8. Allow trace to fully stabilize.
9. Use the peak marker function to determine the maximum power level.
10. If measured value exceeds limit, reduce RBW (no less than 3 kHz) and repeat.
11. The resulting peak PSD level must be 8dBm.

#### Test Configuration

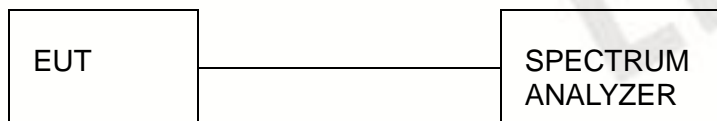

#### Test Results

Raw data reference to Appendix Test Data for Bluetooth LE Section 3.

### 3.5. 6dB Bandwidth

#### Limit

For digital modulation systems, the minimum 6 dB bandwidth shall be at least 500 kHz

#### Test Procedure

The transmitter output was connected to the spectrum analyzer through an attenuator. The bandwidth of the fundamental frequency was measured by spectrum analyzer with 100 KHz RBW and 300 KHz VBW. The 6dB bandwidth is defined as the total spectrum the power of which is higher than peak power minus 6dB.

#### Test Configuration



#### Test Results

Raw data reference to Appendix Test Data for Bluetooth LE Section 1.

### 3.6. Out-of-band Emissions

#### Limit

In any 100 kHz bandwidth outside the frequency band in which the spread spectrum or digitally modulated intentional radiator is operating, the radio frequency power that is produced by the intentional radiator shall be at least 20 dB below that in the 100 kHz bandwidth within the band that contains the highest level of the desired power, based on either an RF conducted or a radiated measurement, provided the transmitter demonstrates compliance with the peak conducted power limits. If the transmitter complies with the conducted power limits based on the use of RMS averaging over a time interval, as permitted under paragraph (b)(3) of this section, the attenuation required under this paragraph shall be 30 dB instead of 20 dB. Attenuation below the general limits specified in §15.209(a) is not required.

#### Test Procedure

Connect the transmitter output to spectrum analyzer using a low loss RF cable, and set the spectrum analyzer to RBW=100 kHz, VBW= 300 kHz, peak detector, and max hold. Measurements utilizing these settings are made of the in-band reference level, band edge and out-of-band emissions.

#### Test Configuration

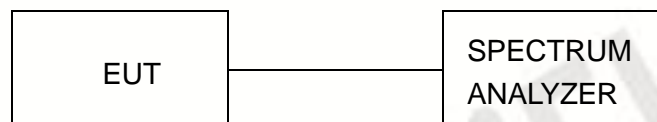

#### Test Results

Raw data reference to Appendix Test Data for Bluetooth LE Section 4.

### 3.7. Antenna Requirement

#### Standard Applicable

**For intentional device, according to FCC 47 CFR Section 15.203:**

An intentional radiator shall be designed to ensure that no antenna other than that furnished by the responsible party shall be used with the device. The use of a permanently attached antenna or of an antenna that uses a unique coupling to the intentional radiator, the manufacturer may design the unit so that a broken antenna can be replaced by the user, but the use of a standard antenna jack or electrical connector is prohibited

**FCC CFR Title 47 Part 15 Subpart C Section 15.247(c) (1) (I):**

(i) Systems operating in the 2400-2483.5 MHz band that is used exclusively for fixed. Point-to-point operations may employ transmitting antennas with directional gain greater than 6dBi provided the maximum conducted output power of the intentional radiator is reduced by 1 dB for every 3 dB that the directional gain of the antenna exceeds 6dBi.

#### Test Result:

The maximum gain of antenna was 0.17dBi

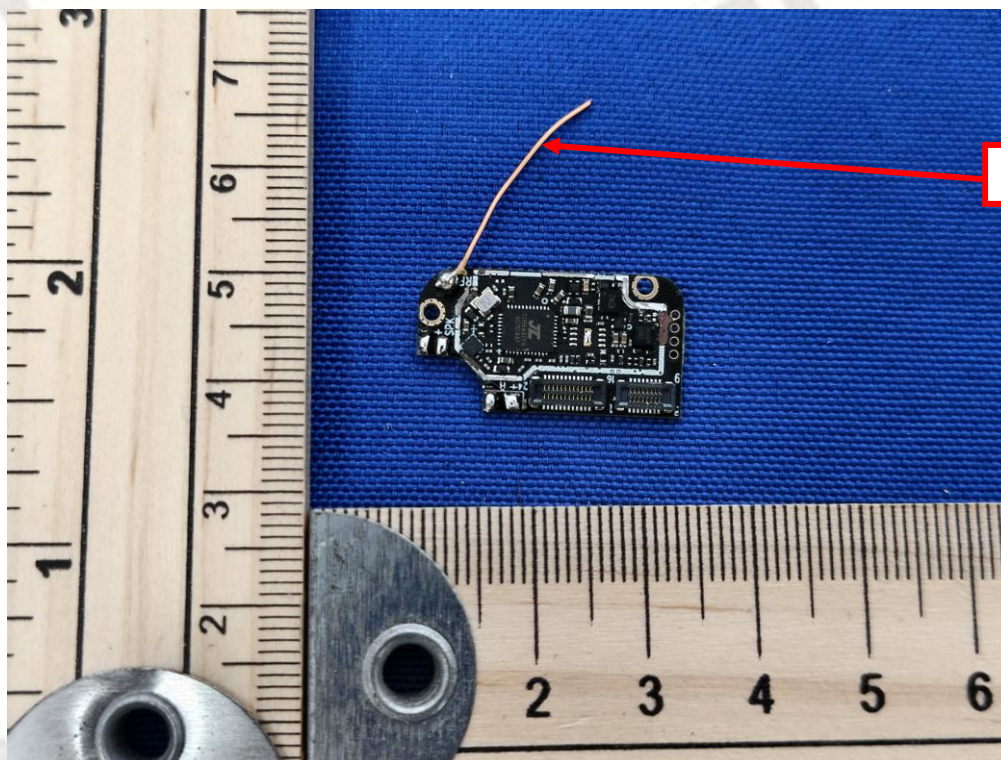



### 4. Test Setup Photos of the EUT

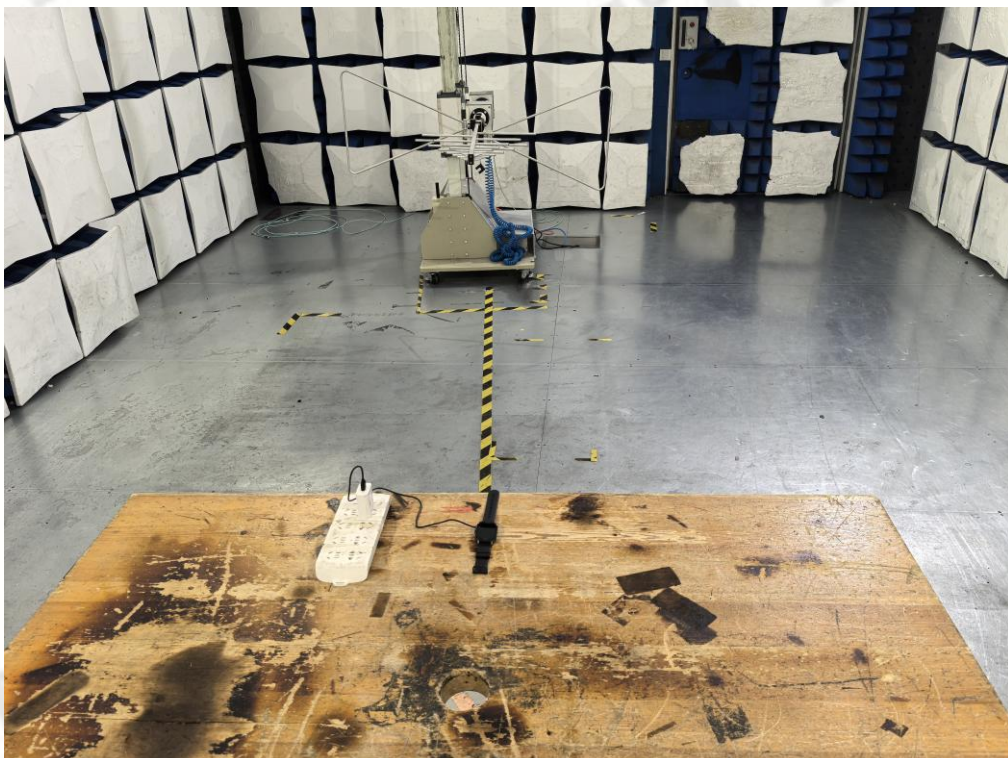

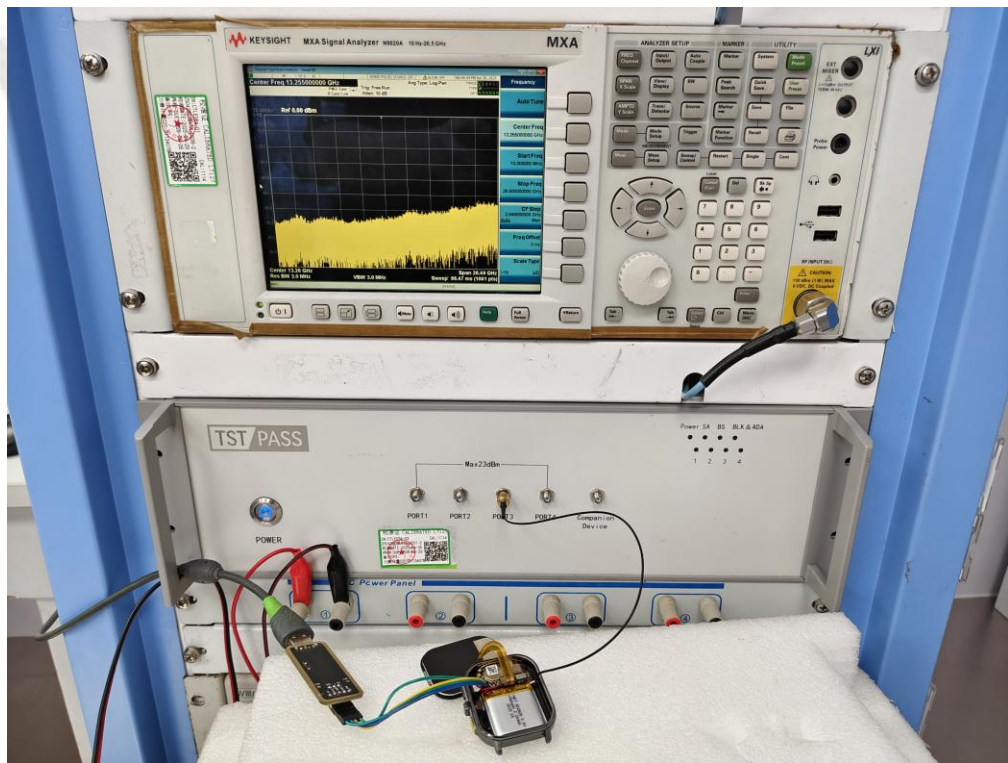



## 5. External and Internal Photos of the EUT

Reference to the test report No. CTL2505095041-WF01

\*\*\*\*\* End of Report \*\*\*\*\*