

FCC Radio Test Report

FCC ID: 2ANR7-TPMS6

Report No. : BTL-FCCP-3-2502T052
Equipment : Tire-pressure monitoring system
Model Name : TPMS6
Brand Name : Snap-on
Applicant : ATEQ INSTRUMENTS (ASIA) PTE LTD.TAIWAN BRANCH
(SINGAPORE)
Address : NO.3, LANE 223, SAN JIA DONG STREET, 40642, TAICHUNG, TAIWAN
Radio Function : Short Range Devices
FCC Rule Part(s) : FCC CFR Title 47, Part 15, Subpart C (15.249)
Measurement Procedure(s) : ANSI C63.10-2013
Date of Receipt : 2025/2/13
Date of Test : 2025/3/3~ 2025/4/2
Issued Date : 2025/5/26

The above equipment has been tested and found in compliance with the requirement of the above standards by BTL Inc.

Prepared by : Brett Shen
Brett Shen, Engineer

Approved by : Jerry Chuang
Jerry Chuang, Supervisor

**BTL Inc.**

No.18, Ln. 171, Sec. 2, Jiuzong Rd., Neihu Dist., Taipei City 114, Taiwan

Tel: +886-2-2657-3299 Fax: +886-2-2657-3331 Web: www.newbtl.com Service mail: btl_qa@newbtl.com

Declaration

BTL represents to the client that testing is done in accordance with standard procedures as applicable and that test instruments used has been calibrated with standards traceable to international standard(s) and/or national standard(s).

BTL's reports apply only to the specific samples tested under conditions. It is manufacture's responsibility to ensure that additional production units of this model are manufactured with the identical electrical and mechanical components. **BTL** assumes no responsibility for the data provided by the Customer, any statements, inferences or generalizations drawn by the customer or others from the reports issued by **BTL**.

This report is the confidential property of the client. As a mutual protection to the clients, the public and ourselves, the test report shall not be reproduced, except in full, without our written approval.

BTL's laboratory quality assurance procedures are in compliance with the **ISO/IEC 17025** requirements, and accredited by the conformity assessment authorities listed in this test report.

BTL is not responsible for the sampling stage, so the results only apply to the sample as received.

The information, data and test plan are provided by manufacturer which may affect the validity of results, so it is manufacturer's responsibility to ensure that the apparatus meets the essential requirements of applied standards and in all the possible configurations as representative of its intended use.

Limitation

For the use of the authority's logo is limited unless the Test Standard(s)/Scope(s)/Item(s) mentioned in this test report is (are) included in the conformity assessment authorities acceptance respective.

Please note that the measurement uncertainty is provided for informational purpose only and are not use in determining the Pass/Fail results.

CONTENTS

REVISION HISTORY	4
1 SUMMARY OF TEST RESULTS	5
1.1 TEST FACILITY	6
1.2 MEASUREMENT UNCERTAINTY	6
1.3 TEST ENVIRONMENT CONDITIONS	6
1.4 TABLE OF PARAMETERS OF TEXT SOFTWARE SETTING	6
1.5 DUTY CYCLE	7
2 GENERAL INFORMATION	8
2.1 DESCRIPTION OF EUT	8
2.2 TEST MODES	9
2.3 BLOCK DIAGRAM SHOWING THE CONFIGURATION OF SYSTEM TESTED	10
2.4 SUPPORT UNITS	11
3 AC POWER LINE CONDUCTED EMISSIONS TEST	12
3.1 LIMIT	12
3.2 TEST PROCEDURE	12
3.3 DEVIATION FROM TEST STANDARD	13
3.4 TEST SETUP	13
3.5 TEST RESULT	13
4 RADIATED EMISSIONS TEST	14
4.1 LIMIT	14
4.2 TEST PROCEDURE	15
4.3 DEVIATION FROM TEST STANDARD	15
4.4 TEST SETUP	15
4.5 EUT OPERATING CONDITIONS	17
4.6 TEST RESULT – 9 KHZ TO 30 MHZ	17
4.7 TEST RESULT – 30 MHZ TO 1 GHZ	17
4.8 TEST RESULT – ABOVE 1 GHZ	17
5 BANDWIDTH TEST	18
5.1 APPLIED PROCEDURES / LIMIT	18
5.2 TEST PROCEDURE	18
5.3 DEVIATION FROM STANDARD	18
5.4 TEST SETUP	18
5.5 EUT OPERATION CONDITIONS	18
5.6 TEST RESULTS	18
6 LIST OF MEASURING EQUIPMENTS	19
7 EUT TEST PHOTO	20
8 EUT PHOTOS	20
APPENDIX A AC POWER LINE CONDUCTED EMISSIONS	21
APPENDIX B RADIATED EMISSIONS - 9 KHZ TO 30 MHZ	26
APPENDIX C RADIATED EMISSIONS - 30 MHZ TO 1 GHZ	31
APPENDIX D RADIATED EMISSIONS - ABOVE 1 GHZ	34
APPENDIX E BANDWIDTH	40

REVISION HISTORY

Report No.	Version	Description	Issued Date	Note
BTL-FCCP-3-2502T052	R00	Original Report.	2025/4/29	Invalid
BTL-FCCP-3-2502T052	R01	Revised report to address TCB's comments.	2025/5/26	Valid

1 SUMMARY OF TEST RESULTS

Test procedures according to the technical standards.

Standard(s) Section	Description	Test Result	Judgement	Remark
15.207	AC Power Line Conducted Emissions	APPENDIX A	Pass	-----
15.205 15.209 15.249(a)(d)	Radiated Emissions	APPENDIX B APPENDIX C APPENDIX D	Pass	-----
15.215(c)	Bandwidth	APPENDIX E	Pass	-----

Statement of Conformity

The statement of conformity is based on the binary decision rule according to IEC Guide 115 and ILAC G8 "simple acceptance" principle. Without considering measurement uncertainty, its specific risk is less than 50% PFA. (PFA: Probability of False Accept)

NOTE:

- (1) "N/A" denotes test is not applicable in this Test Report.
- (2) The report format version is TP.1.1.1.

1.1 TEST FACILITY

The test locations stated below are under the TAF Accreditation Number 0659.

The test location(s) used to collect the test data in this report are:

No. 68-1, Ln. 169, Sec. 2, Datong Rd., Xizhi Dist., New Taipei City 221, Taiwan
(FCC DN: TW0659)

C05 CB08 CB11 SR10 SR11

No. 72, Ln. 169, Sec. 2, Datong Rd., Xizhi Dist., New Taipei City 221, Taiwan
(FCC DN: TW0659)

C06 CB21 CB22

1.2 MEASUREMENT UNCERTAINTY

The reported uncertainty of measurement $y \pm U$, where expanded uncertainty U is based on a standard uncertainty multiplied by a coverage factor of $k = 2$, providing a level of confidence of approximately **95 %**.

A. AC power line conducted emissions test:

Test Site	Method	Measurement Frequency Range	U (dB)
C05	CISPR	150 kHz ~ 30MHz	3.44

B. Radiated emissions test :

Test Site	Measurement Frequency Range	U (dB)
CB21	0.03 GHz ~ 0.2 GHz	4.17
	0.2 GHz ~ 1 GHz	4.72
	1 GHz ~ 6 GHz	5.21
	6 GHz ~ 18 GHz	5.51
	18 GHz ~ 26 GHz	3.69
	26 GHz ~ 40 GHz	4.23

C. Conducted test :

Test Item	U (dB)
Bandwidth	0.5334

NOTE:

Unless specifically mentioned, the uncertainty of measurement has not been taken into account to declare the compliance or non-compliance to the specification.

1.3 TEST ENVIRONMENT CONDITIONS

Test Item	Environment Condition	Test Voltage	Tested by
AC Power Line Conducted Emissions	24 °C, 53 %	AC 120V	Ken Lan
Radiated emissions below 1 GHz	Refer to data	AC 120V	Mark Wang
Radiated emissions above 1 GHz	Refer to data	AC 120V	Mark Wang
Bandwidth	23 °C, 55 %	DC 5V	Easton Tsai

1.4 TABLE OF PARAMETERS OF TEXT SOFTWARE SETTING

Test Software	Button		
Modulation Mode	2450 MHz		Data Rate
SRD	DEF		-

1.5 DUTY CYCLE

If duty cycle is $\geq 98\%$, duty factor is not required.
 If duty cycle is $< 98\%$, duty factor shall be considered.

Mode	ON (ms)	Numbers (ON)	On Time (B) (ms)	Period (ON+OFF) (ms)	Duty Cycle (%)	Duty Factor (dB)
SRD	23.980	1	23.980	46.900	51.13%	2.91

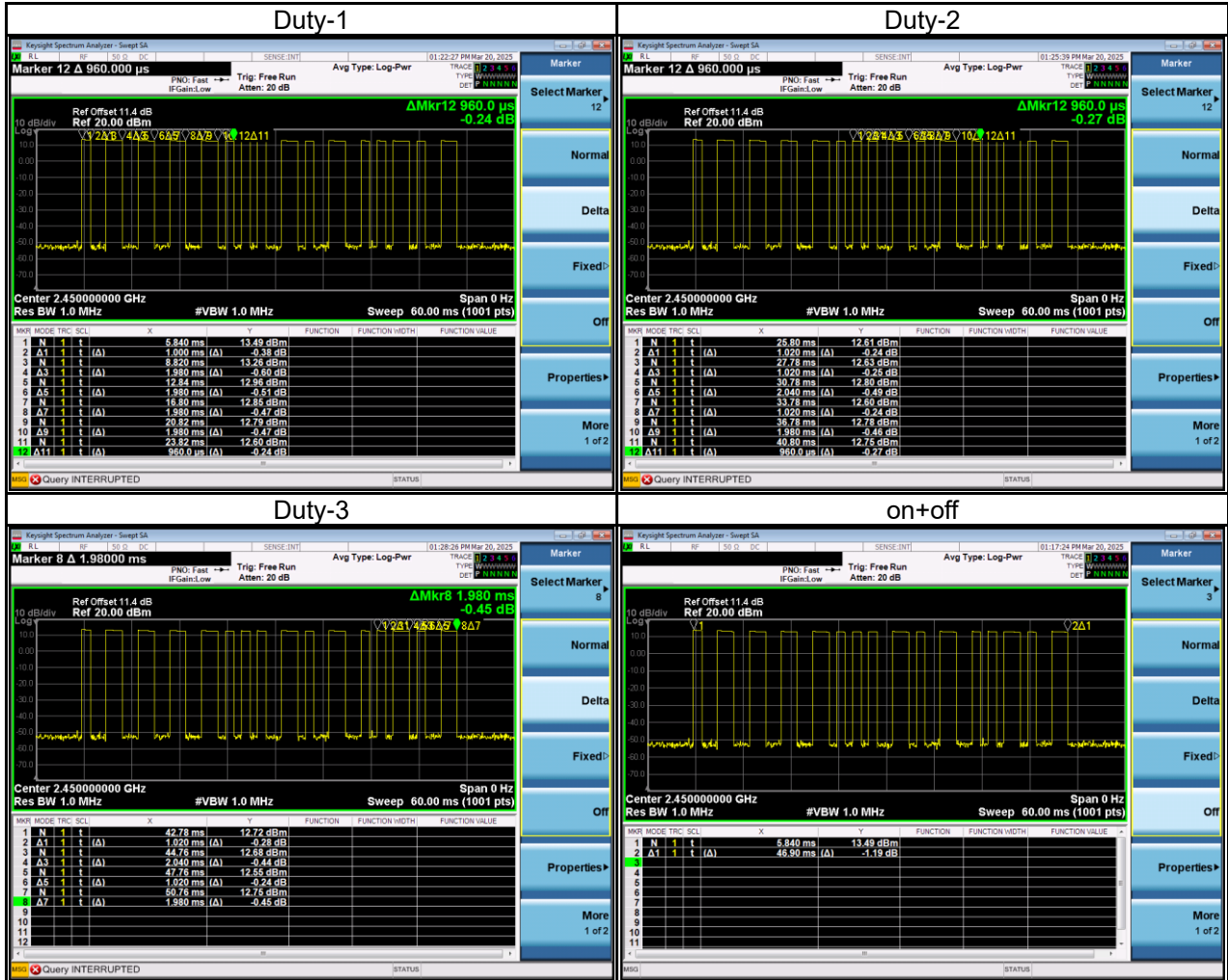

2 GENERAL INFORMATION

2.1 DESCRIPTION OF EUT

Equipment	Tire-pressure monitoring system
Model Name	TPMS6
Brand Name	Snap-on
Model Difference	N/A
Power Source	DC Voltage supplied from AC/DC adapter.
Power Rating	I/P: AC 100-240V~50/60Hz 0.3A O/P: +5.0V---2.0A, 10.0W
Products Covered	1* Adapter: DEE VAN / DSA-10PFP-05 050200 1* WIFI 2.4GHz Module: ESPRESSIF / ESP32-C3-WROOM-02 1* 2.4GHz OOK Module: TEXAS / CC2500 1* USB Cable 4* Plug
Frequency Range	2450 MHz
Operation Frequency	2450 MHz
Modulation Technology	OOK
Transfer Rate	1 Mbps
Field Strength	86.52 dBμV/m @ 3 m (Average)
Test Model	TPMS6
Sample Status	Engineering Sample
EUT Modification(s)	N/A

NOTE:

(1) The above EUT information is declared by manufacturer and for more detailed features description, please refers to the manufacturer's specifications or user's manual.

(2) Channel List:

Channel	Frequency (MHz)
01	2450

(3) Table for Filed Antenna:

Antenna	Brand	P/N	Type	Connector	Gain (dBi)
1	molex	1461539150	Flex	MHF	2.8

(4) The above Antenna information are derived from the antenna data sheet provided by manufacturer and for more detailed features description, please refer to the manufacturer's specifications, the laboratory shall not be held responsible.

2.2 TEST MODES

Test Items	Test mode	Channel	Note
AC power line conducted emissions	Normal/Idle	-	-
Transmitter Radiated Emissions (below 1GHz)	SRD	01	-
Transmitter Radiated Emissions (above 1GHz)	SRD	01	Fundamental
	SRD	01	Harmonic
Transmitter Radiated Emissions (above 18GHz)	SRD	01	-
Bandwidth	SRD	01	-

NOTE:

- (1) For radiated emission band edge test, both Vertical and Horizontal are evaluated, but only the worst case (Horizontal) is recorded.
- (2) All X, Y and Z axes are evaluated, but only the worst case (X axis) is recorded.

2.3 BLOCK DIAGRAM SHOWING THE CONFIGURATION OF SYSTEM TESTED

Equipment letters and Cable numbers refer to item numbers described in the tables of clause 2.4.

AC Power Line Conducted Emissions Test

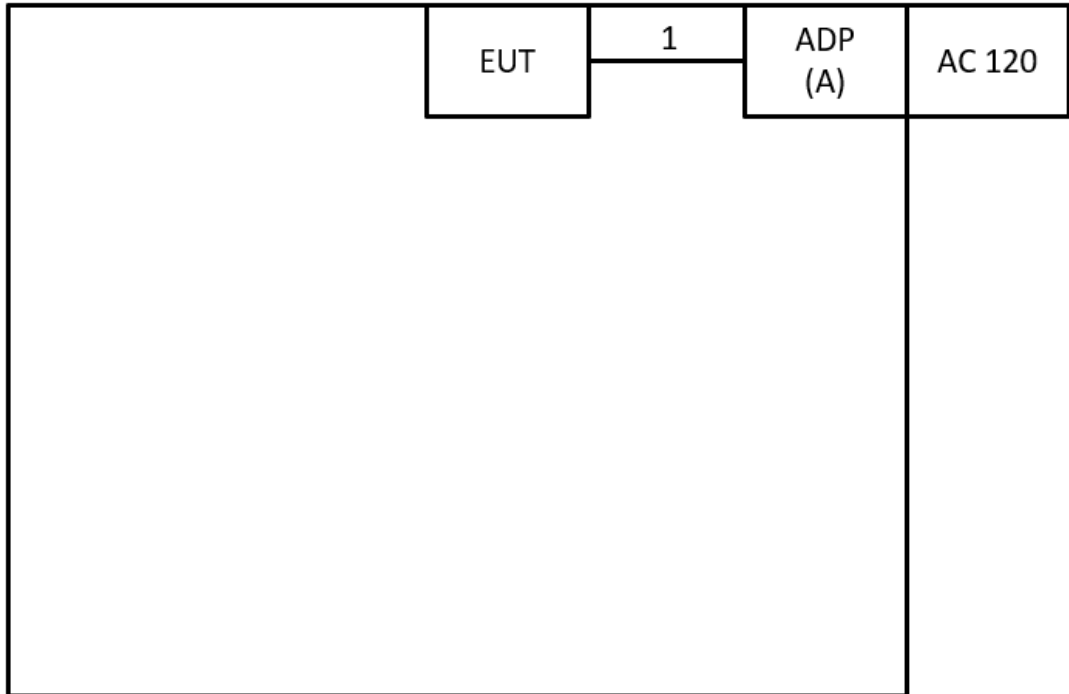

Radiated Emissions Test

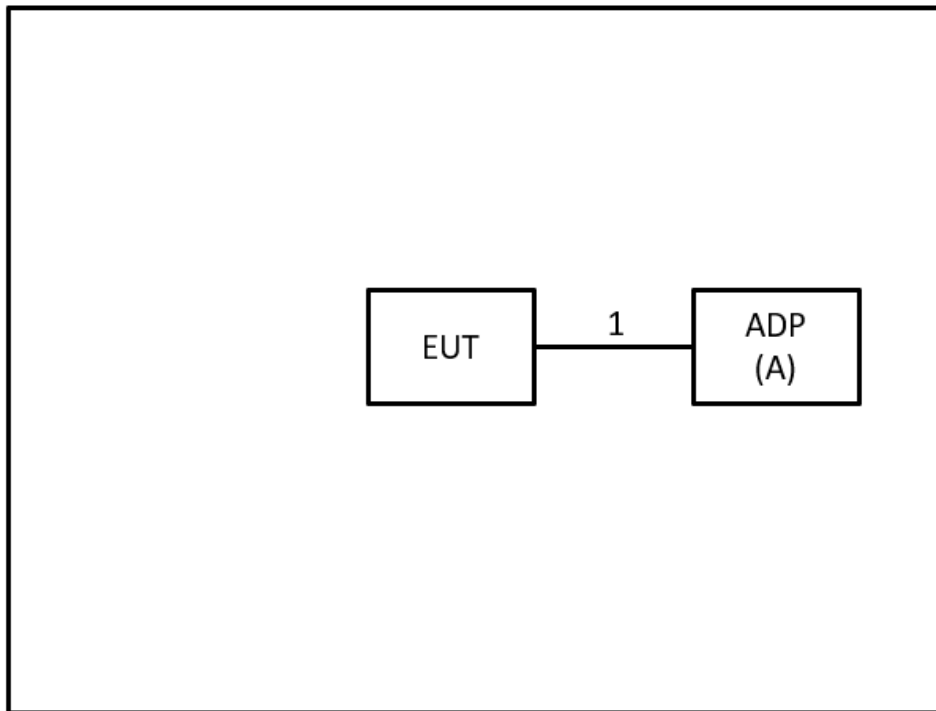

2.4 SUPPORT UNITS

Item	Equipment	Brand	Model No.	Series No.	Remarks
A	ADP	DEEVAN	DSA-10PFP-05	N/A	Supplied by test requester

Item	Shielded	Ferrite Core	Length	Cable Type	Remarks
1	N/A	N/A	1.05m	USB Cable	Supplied by test requester

3 AC POWER LINE CONDUCTED EMISSIONS TEST

3.1 LIMIT

Frequency (MHz)	Limit (dB μ V)	
	Quasi-peak	Average
0.15 - 0.5	66 - 56 *	56 - 46 *
0.50 - 5.0	56	46
5.0 - 30.0	60	50

NOTE:

- (1) The tighter limit applies at the band edges.
- (2) The limit of " * " marked band means the limitation decreases linearly with the logarithm of the frequency in the range.
- (3) The test result calculated as following:
 Measurement Value = Reading Level + Correct Factor
 Correct Factor = Insertion Loss + Cable Loss + Attenuator Factor (if use)
 Margin Level = Measurement Value – Limit Value
 Calculation example:

Reading Level (dB μ V)		Correct Factor (dB)		Measurement Value (dB μ V)
38.22	+	3.45	=	41.67

Measurement Value (dB μ V)		Limit Value (dB μ V)		Margin Level (dB)
41.67	-	60	=	-18.33

The following table is the setting of the receiver.

Receiver Parameter	Setting
Attenuation	10 dB
Start Frequency	0.15 MHz
Stop Frequency	30 MHz
IF Bandwidth	9 KHz

3.2 TEST PROCEDURE

- a. The EUT was placed 0.8 m above the horizontal ground plane with the EUT being connected to the power mains through a line impedance stabilization network (LISN).
 All other support equipment were powered from an additional LISN(s).
 The LISN provides 50 Ohm/50uH of impedance for the measuring instrument.
- b. Interconnecting cables that hang closer than 40 cm to the ground plane shall be folded back and forth in the center forming a bundle to keep the cable above 40 cm.
- c. Excess I/O cables that are not connected to a peripheral shall be bundled in the center.
 The end of the cable will be terminated, using the correct terminating impedance.
 The overall length shall not exceed 1 m.
- d. The LISN is spaced at least 80 cm from the nearest part of the EUT chassis.
- e. For the actual test configuration, please refer to the related Item – EUT TEST PHOTO.

NOTE:

- (1) In the results, each reading is marked as Peak, QP or AVG per the detector used.
 BW=9 kHz (6 dB Bandwidth)
- (2) All readings are Peak unless otherwise stated QP or AVG in column of Note. Both the QP and the AVG readings must be less than the limit for compliance.

3.3 DEVIATION FROM TEST STANDARD

No deviation.

3.4 TEST SETUP

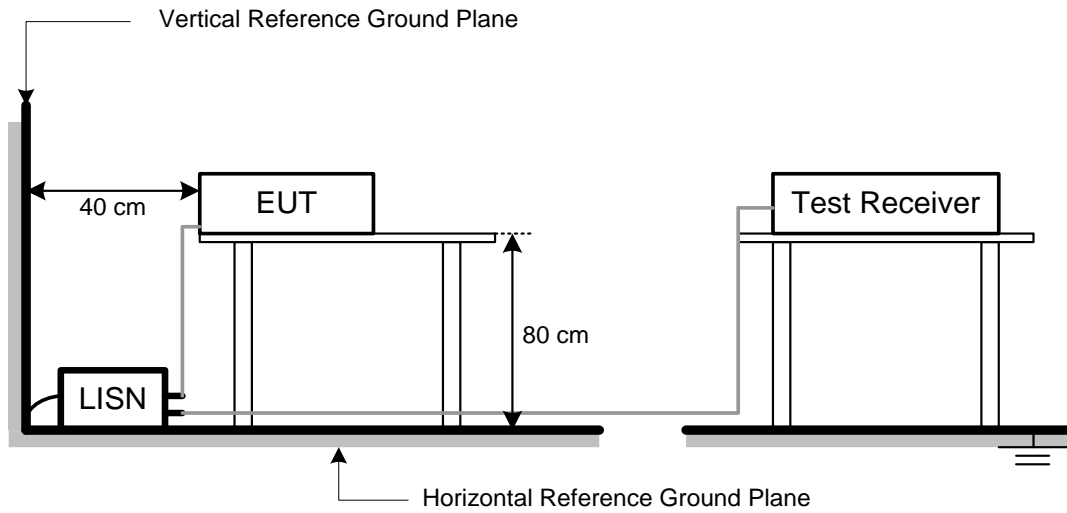

3.5 TEST RESULT

Please refer to the APPENDIX A.

4 RADIATED EMISSIONS TEST

4.1 LIMIT

In case the emission fall within the restricted band specified on 15.205, then the 15.209 limit in the table below has to be followed.

LIMITS OF RADIATED EMISSIONS MEASUREMENT (9 kHz to 1000 MHz)

Frequency (MHz)	Field Strength (microvolts/meter)	Measurement Distance (meters)
0.009~0.490	2400/F(KHz)	300
0.490~1.705	24000/F(KHz)	30
1.705~30.0	30	30
30~88	100	3
88~216	150	3
216~960	200	3
960~1000	500	3

LIMITS OF RADIATED EMISSIONS MEASUREMENT (Above 1000 MHz)

Frequency (MHz)	Radiated Emissions (dBuV/m)		Measurement Distance (meters)
	Peak	Average	
Above 1000	74	54	3

NOTE:

- (1) The limit for radiated test was performed according to FCC CFR Title 47, Part 15, Subpart C.
- (2) The tighter limit applies at the band edges.
- (3) Emission level (dBuV/m)=20log Emission level (uV/m).
- (4) The test result calculated as following:

Measurement Value = Reading Level + Correct Factor

Correct Factor = Antenna Factor + Cable Loss - Amplifier Gain(if use)

Margin Level = Measurement Value - Limit Value

Calculation example:

Reading Level (dBμV)		Correct Factor (dB/m)		Measurement Value (dBμV/m)
41.91	+	-8.36	=	33.55

Measurement Value (dBμV/m)		Limit Value (dBμV/m)		Margin Level (dB)
33.55	-	43.50	=	-9.95

Spectrum Parameter	Setting
Attenuation	Auto
Start Frequency	1000 MHz
Stop Frequency	10th carrier harmonic
RBW / VBW (Emission in restricted band)	1MHz / 3MHz for Peak, 1MHz / 1/T for Average

Spectrum Parameter	Setting
Attenuation	Auto
Start ~ Stop Frequency	9KHz~90KHz for PK/AVG detector
Start ~ Stop Frequency	90KHz~110KHz for QP detector
Start ~ Stop Frequency	110KHz~490KHz for PK/AVG detector
Start ~ Stop Frequency	490KHz~30MHz for QP detector
Start ~ Stop Frequency	30MHz~1000MHz for QP detector

4.2 TEST PROCEDURE

- a. The measuring distance of 1 m shall be used for measurements. The EUT was placed on the top of a rotating table 0.8 meter above the ground at a 3 meter semi-anechoic chamber. The table was rotated 360 degrees to determine the position of the highest radiation.(below 30MHz)
- b. The measuring distance of 3 m shall be used for measurements. The EUT was placed on the top of a rotating table 0.8 meter above the ground at a 3 meter semi-anechoic chamber. The table was rotated 360 degrees to determine the position of the highest radiation.(below 1GHz)
- c. The measuring distance of 3 m shall be used for measurements. The EUT was placed on the top of a rotating table 1.5 meter above the ground at a 3 meter semi-anechoic chamber. The table was rotated 360 degrees to determine the position of the highest radiation.(above 1GHz)
- d. The height of the equipment or of the substitution antenna shall be 0.8 m or 1.5 m, the height of the test antenna shall vary between 1 m to 4 m. Both horizontal and vertical polarizations of the antenna are set to make the measurement.
- e. For each suspected emission, the EUT was arranged to its worst case and then the antenna was tuned to heights find the maximum reading (used Bore sight function).
- f. The receiver system was set to peak and average detect function and specified bandwidth with maximum hold mode when the test frequency is above 1GHz.
- g. The initial step in collecting radiated emission data is a receiver peak detector mode pre-scanning the measurement frequency range. Significant peaks are then marked and then Quasi Peak detector mode re-measured.
- h. All readings are Peak unless otherwise stated QP in column of Note. Peak denotes that the Peak reading compliance with the QP Limits and then QP Mode measurement didn't perform. (below 1GHz)
- i. All readings are Peak Mode value unless otherwise stated AVG in column of Note. If the Peak Mode Measured value compliance with the Peak Limits and lower than AVG Limits, the EUT shall be deemed to meet both Peak & AVG Limits and then only Peak Mode was measured, but AVG Mode didn't perform. (above 1GHz)
- j. For the actual test configuration, please refer to the related Item – EUT TEST PHOTO.

4.3 DEVIATION FROM TEST STANDARD

No deviation.

4.4 TEST SETUP

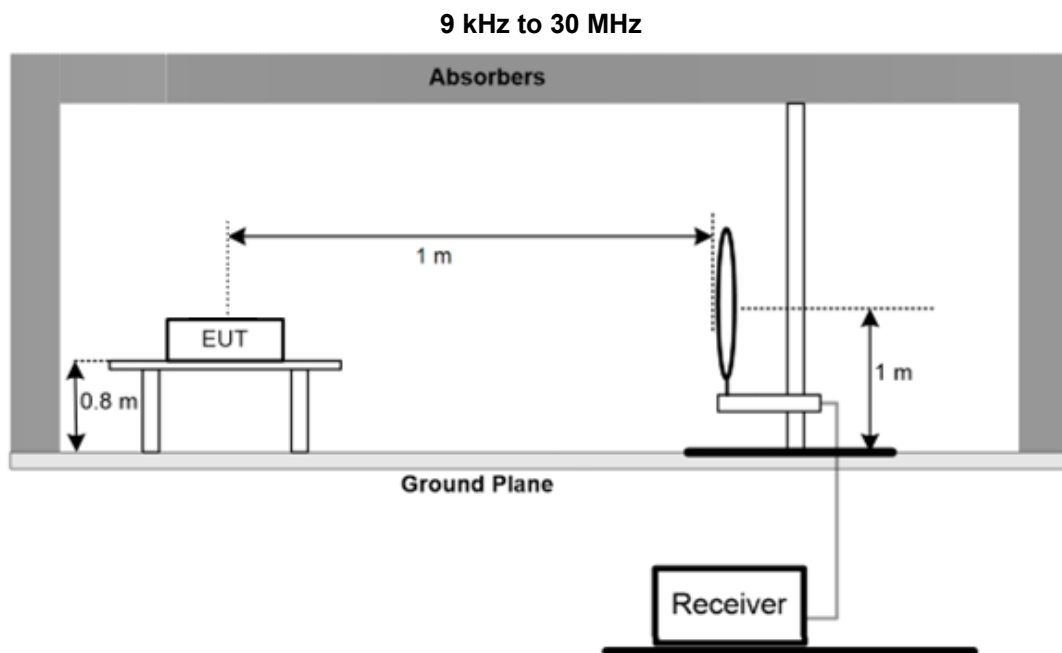

30 MHz to 1 GHz

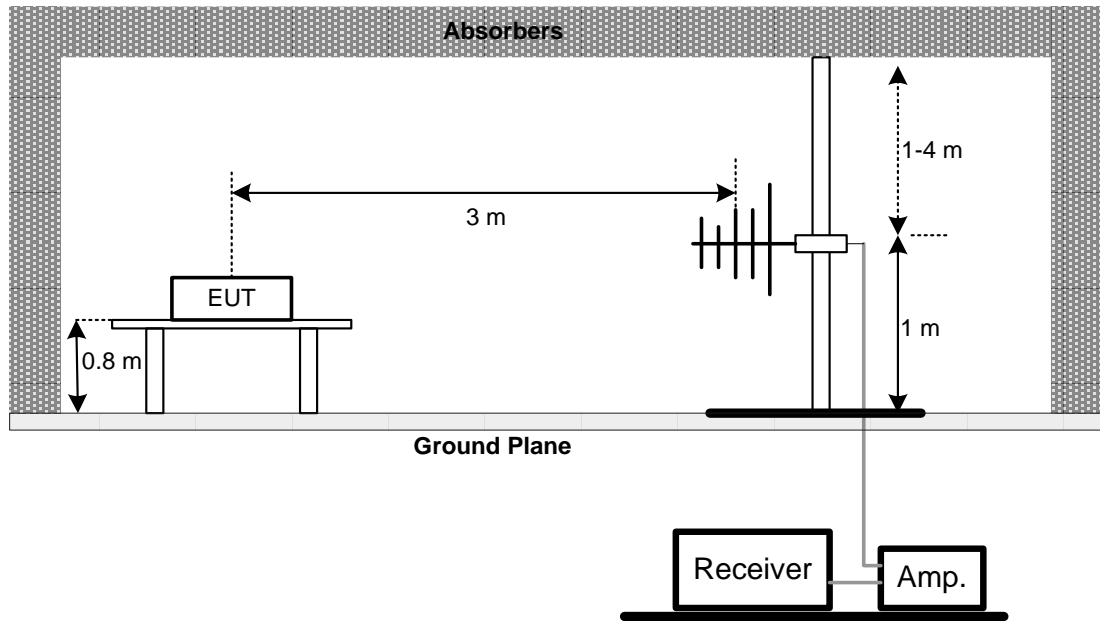

Above 1 GHz

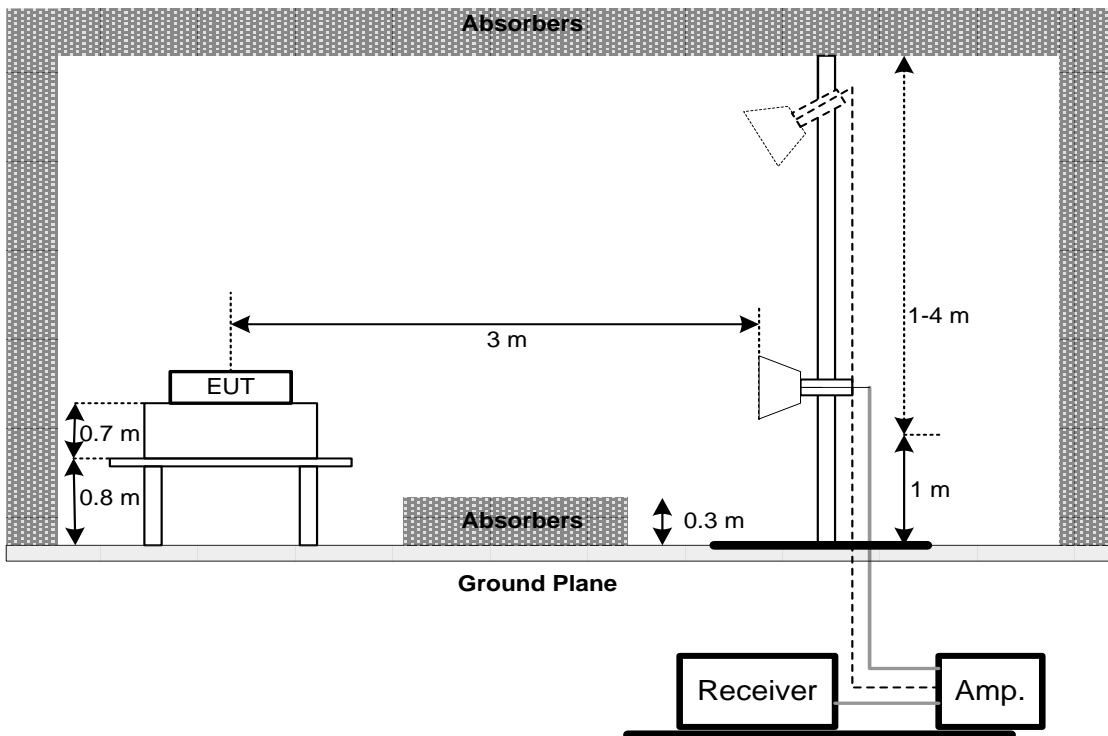

4.5 EUT OPERATING CONDITIONS

The EUT was programmed to be in continuously transmitting mode.

4.6 TEST RESULT – 9 KHZ TO 30 MHZ

Please refer to the APPENDIX B.

4.7 TEST RESULT – 30 MHZ TO 1 GHZ

Please refer to the APPENDIX C.

4.8 TEST RESULT – ABOVE 1 GHZ

Please refer to the APPENDIX D.

NOTE:

- (1) No limit: This is fundamental signal, the judgment is not applicable.
For fundamental signal judgment was referred to Peak output test.

5 BANDWIDTH TEST

5.1 APPLIED PROCEDURES / LIMIT

Intentional radiators operating under the alternative provisions to the general emission limits, as contained in §§15.217 through 15.257 and in subpart E of this part, must be designed to ensure that the 20 dB bandwidth of the emission, or whatever bandwidth may otherwise be specified in the specific rule section under which the equipment operates, is contained within the frequency band designated in the rule section under which the equipment is operated. In the case of intentional radiators operating under the provisions of subpart E, the emission bandwidth may span across multiple contiguous frequency bands identified in that subpart. The requirement to contain the designated bandwidth of the emission within the specified frequency band includes the effects from frequency sweeping, frequency hopping and other modulation techniques that may be employed as well as the frequency stability of the transmitter over expected variations in temperature and supply voltage. If a frequency stability is not specified in the regulations, it is recommended that the fundamental emission be kept within at least the central 80% of the permitted band in order to minimize the possibility of out-of-band operation.

5.2 TEST PROCEDURE

- a. The EUT was directly connected to the spectrum analyzer and antenna output port as show in the block diagram below,
- b. Spectrum Setting : RBW= 100KHz, VBW=300KHz, Sweep time = 2.5 ms.

5.3 DEVIATION FROM STANDARD

No deviation.

5.4 TEST SETUP

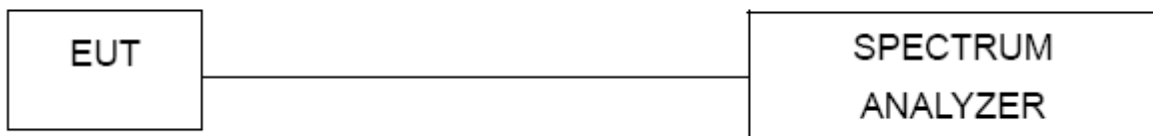

5.5 EUT OPERATION CONDITIONS

The EUT tested system was configured as the statements of 4.1.5 unless otherwise a special operating condition is specified in the follows during the testing.

5.6 TEST RESULTS

Please refer to the APPENDIX E.

6 LIST OF MEASURING EQUIPMENTS

AC Power Line Conducted Emissions						
Item	Kind of Equipment	Manufacturer	Type No.	Serial No.	Calibrated Date	Calibrated Until
1	TWO-LINE V-NETWORK	R&S	ENV216	101521	2024/9/5	2025/9/4
2	Test Cable	EMCI	EMCCFD300-BM-BMR-5000	220331	2024/3/30	2025/3/29
3	EMI Test Receiver	R&S	ESR 7	101433	2024/11/7	2025/11/6
4	Measurement Software	EZ	EZ EMC (Version NB-03A1-01)	N/A	N/A	N/A

Radiated Emissions						
Item	Kind of Equipment	Manufacturer	Type No.	Serial No.	Calibrated Date	Calibrated Until
1	Preamplifier	EMCI	EMC330N	980850	2024/9/5	2025/9/4
2	Preamplifier	EMCI	EMC118A45SE	980819	2025/3/5	2026/3/4
3	Pre-Amplifier	EMCI	EMC184045SE	980907	2024/9/4	2025/9/3
4	Preamplifier	EMCI	EMC001340	980579	2024/9/4	2025/9/3
5	Test Cable	EMCI	EMC104-SM-1000	180809	2025/3/5	2026/3/4
6	Test Cable	EMCI	EMC104-SM-SM-3000	220322	2025/3/5	2026/3/4
7	Test Cable	EMCI	EMC104-SM-SM-7000	220324	2025/3/5	2026/3/4
8	EXA Signal Analyzer	keysight	N9020B	MY57120120	2025/2/19	2026/2/18
9	Loop Ant	Electro-Metrics	EMCI-LPA600	291	2024/9/9	2025/9/8
10	Horn Antenna	RFSPIN	DRH18-E	211202A18EN	2024/5/9	2025/5/8
11	Horn Ant	Schwarzbeck	BBHA 9170D	1136	2024/5/17	2025/5/16
12	Log-bicon Antenna	Schwarzbeck	VULB9168	1369	2024/6/14	2025/6/13
13	6dB Attenuator	EMCI	EMCI-N-6-06	AT-06001	2024/6/14	2025/6/13
14	Test Cable	EMCI	EMC101G-KM-KM-3000	220329	2025/3/12	2026/3/11
15	Test Cable	EMCI	EMC102-KM-KM-1000	220327	2025/3/12	2026/3/11
16	Measurement Software	EZ	EZ EMC (Version NB-03A1-01)	N/A	N/A	N/A

Bandwidth						
Item	Kind of Equipment	Manufacturer	Type No.	Serial No.	Calibrated Date	Calibrated Until
1	EXA Spectrum Analyzer	Keysight	N9010A	MY56480489	2025/1/2	2026/1/1

Remark: "N/A" denotes no model name, no serial no. or no calibration specified.
All calibration period of equipment list is one year.

7 EUT TEST PHOTO

Please refer to document Appendix No.: TP-2502T052-FCCP-1 (APPENDIX-TEST PHOTOS).

8 EUT PHOTOS

Please refer to document Appendix No.: EP-2502T052-3 (APPENDIX-EUT PHOTOS).

APPENDIX A AC POWER LINE CONDUCTED EMISSIONS

Test Mode	Normal	Tested Date	2025/3/4
Test Frequency	-	Phase	Line

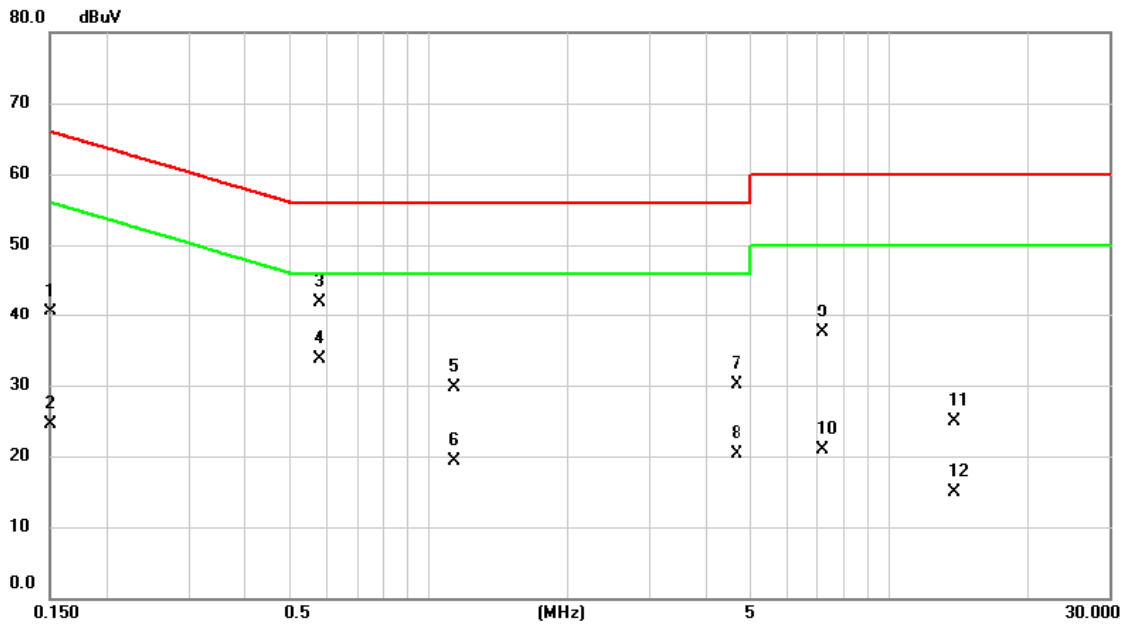

No.	Mk.	Freq. MHz	Reading Level dBuV	Correct Factor dB	Measure- ment dBuV	Limit dBuV	Margin dB	Detector	Comment
1		0.1500	30.83	9.67	40.50	66.00	-25.50	QP	
2		0.1500	14.76	9.67	24.43	56.00	-31.57	AVG	
3		0.5820	32.33	9.57	41.90	56.00	-14.10	QP	
4	*	0.5820	24.09	9.57	33.66	46.00	-12.34	AVG	
5		1.1332	20.15	9.56	29.71	56.00	-26.29	QP	
6		1.1332	9.70	9.56	19.26	46.00	-26.74	AVG	
7		4.6658	20.47	9.72	30.19	56.00	-25.81	QP	
8		4.6658	10.57	9.72	20.29	46.00	-25.71	AVG	
9		7.1768	27.82	9.70	37.52	60.00	-22.48	QP	
10		7.1768	11.14	9.70	20.84	50.00	-29.16	AVG	
11		13.8278	15.24	9.70	24.94	60.00	-35.06	QP	
12		13.8278	5.13	9.70	14.83	50.00	-35.17	AVG	

REMARKS:

- (1) Measurement Value = Reading Level + Correct Factor.
- (2) Margin Level = Measurement Value - Limit Value.

Test Mode	Normal	Tested Date	2025/3/4
Test Frequency	-	Phase	Neutral

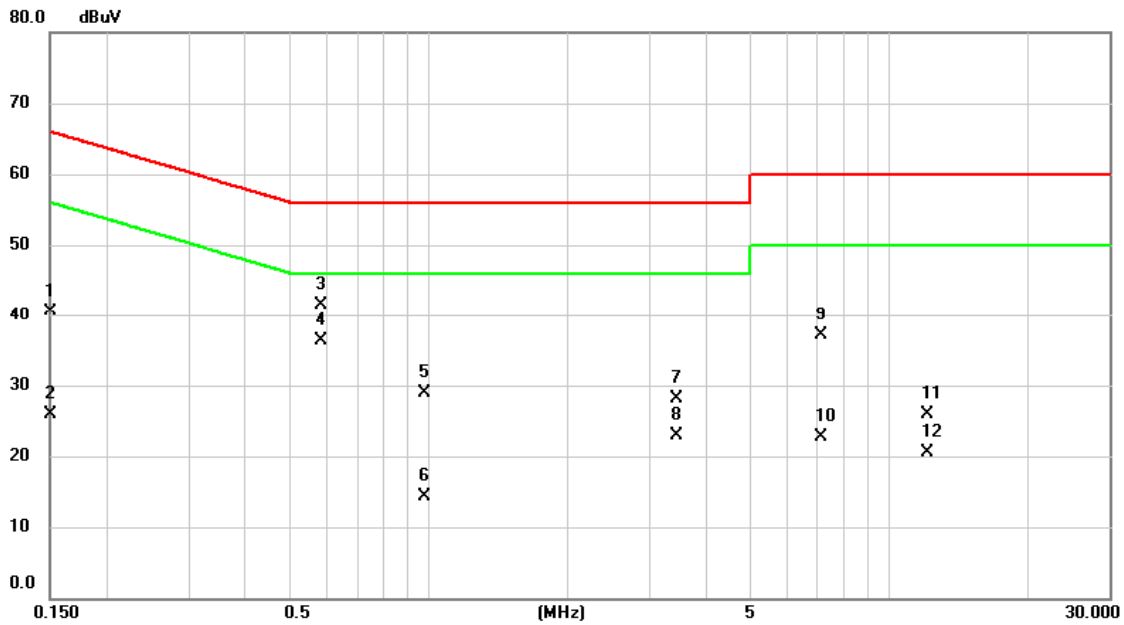

No.	Mk.	Freq. MHz	Reading Level dBuV	Correct Factor dB	Measure- ment dBuV	Limit dBuV	Margin dB	Detector	Comment
1		0.1500	30.81	9.65	40.46	66.00	-25.54	QP	
2		0.1500	16.29	9.65	25.94	56.00	-30.06	AVG	
3		0.5842	31.85	9.56	41.41	56.00	-14.59	QP	
4	*	0.5842	26.73	9.56	36.29	46.00	-9.71	AVG	
5		0.9802	19.27	9.55	28.82	56.00	-27.18	QP	
6		0.9802	4.81	9.55	14.36	46.00	-31.64	AVG	
7		3.4350	18.40	9.69	28.09	56.00	-27.91	QP	
8		3.4350	13.28	9.69	22.97	46.00	-23.03	AVG	
9		7.1250	27.28	9.73	37.01	60.00	-22.99	QP	
10		7.1250	13.01	9.73	22.74	50.00	-27.26	AVG	
11		12.1446	16.26	9.72	25.98	60.00	-34.02	QP	
12		12.1446	10.73	9.72	20.45	50.00	-29.55	AVG	

REMARKS:

- (1) Measurement Value = Reading Level + Correct Factor.
- (2) Margin Level = Measurement Value - Limit Value.

Test Mode	Idle	Tested Date	2025/3/4
Test Frequency	-	Phase	Line

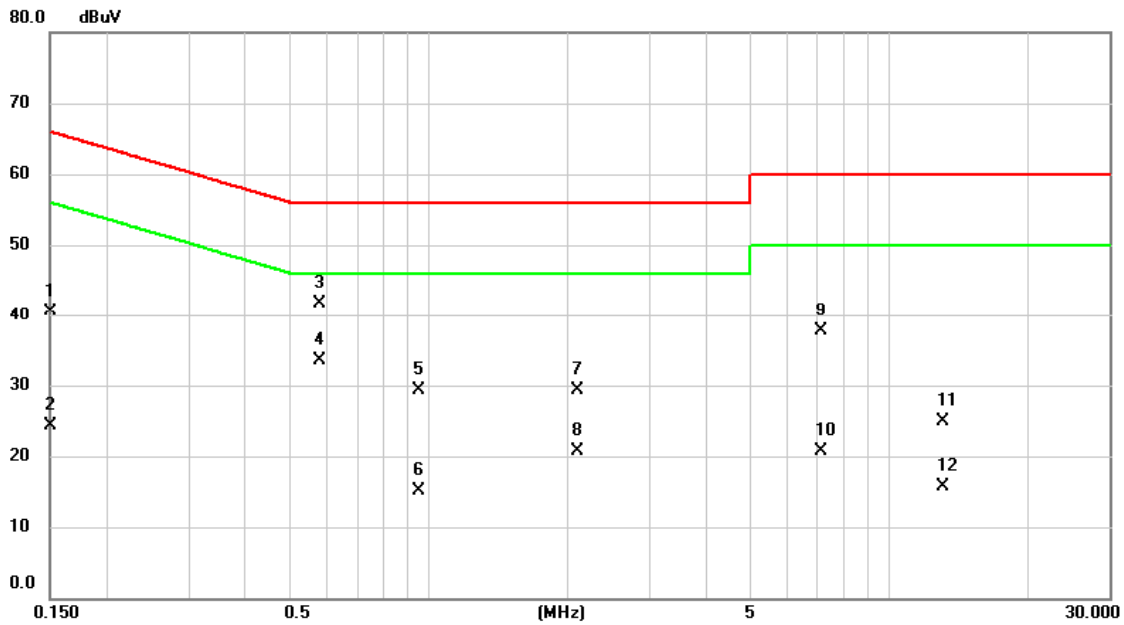

No.	Mk.	Freq. MHz	Reading Level dBuV	Correct Factor dB	Measure- ment dBuV	Limit dBuV	Margin dB	Detector	Comment
1		0.1500	30.82	9.67	40.49	66.00	-25.51	QP	
2		0.1500	14.73	9.67	24.40	56.00	-31.60	AVG	
3		0.5820	32.14	9.57	41.71	56.00	-14.29	QP	
4	*	0.5820	23.86	9.57	33.43	46.00	-12.57	AVG	
5		0.9532	19.78	9.56	29.34	56.00	-26.66	QP	
6		0.9532	5.51	9.56	15.07	46.00	-30.93	AVG	
7		2.1030	19.68	9.55	29.23	56.00	-26.77	QP	
8		2.1030	11.12	9.55	20.67	46.00	-25.33	AVG	
9		7.1115	27.95	9.70	37.65	60.00	-22.35	QP	
10		7.1115	11.07	9.70	20.77	50.00	-29.23	AVG	
11		13.0538	15.31	9.69	25.00	60.00	-35.00	QP	
12		13.0538	5.94	9.69	15.63	50.00	-34.37	AVG	

REMARKS:

- (1) Measurement Value = Reading Level + Correct Factor.
- (2) Margin Level = Measurement Value - Limit Value.

Test Mode	Idle	Tested Date	2025/3/4
Test Frequency	-	Phase	Neutral

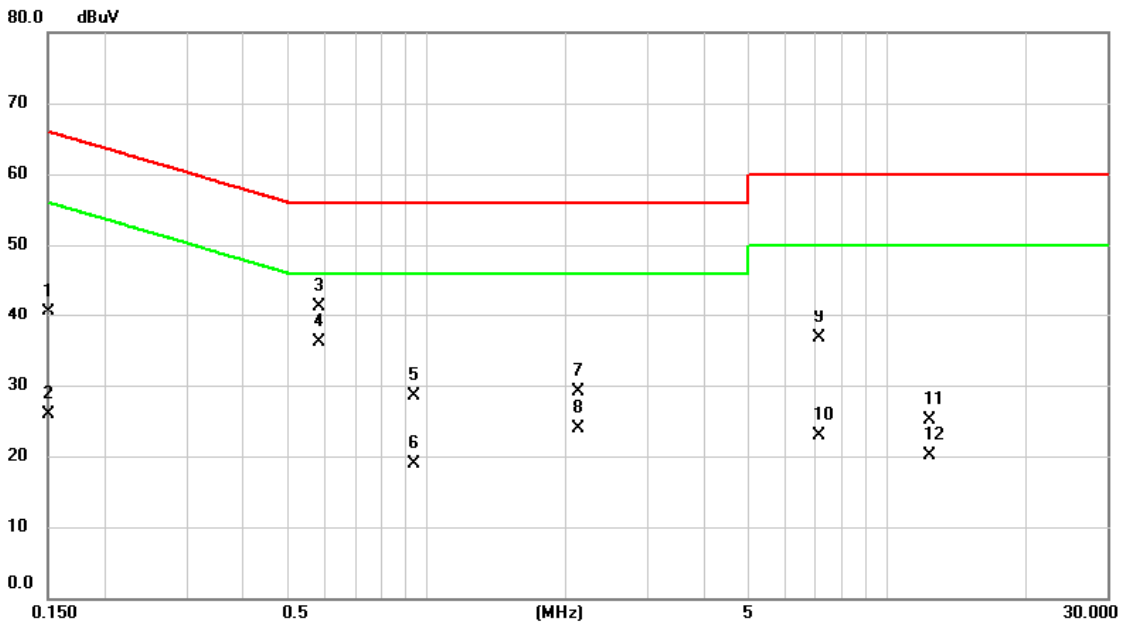

No.	Mk.	Freq. MHz	Reading Level dBuV	Correct Factor dB	Measure- ment dBuV	Limit dBuV	Margin dB	Detector	Comment
1		0.1500	30.81	9.65	40.46	66.00	-25.54	QP	
2		0.1500	16.26	9.65	25.91	56.00	-30.09	AVG	
3		0.5842	31.80	9.56	41.36	56.00	-14.64	QP	
4	*	0.5842	26.63	9.56	36.19	46.00	-9.81	AVG	
5		0.9397	18.91	9.55	28.46	56.00	-27.54	QP	
6		0.9397	9.33	9.55	18.88	46.00	-27.12	AVG	
7		2.1233	19.59	9.57	29.16	56.00	-26.84	QP	
8		2.1233	14.30	9.57	23.87	46.00	-22.13	AVG	
9		7.1160	27.06	9.73	36.79	60.00	-23.21	QP	
10		7.1160	13.17	9.73	22.90	50.00	-27.10	AVG	
11		12.3450	15.33	9.73	25.06	60.00	-34.94	QP	
12		12.3450	10.31	9.73	20.04	50.00	-29.96	AVG	

REMARKS:

- (1) Measurement Value = Reading Level + Correct Factor.
- (2) Margin Level = Measurement Value - Limit Value.

APPENDIX B RADIATED EMISSIONS - 9 KHZ TO 30 MHZ

Test Mode	SRD	Test Date	2025/4/2
Test Frequency	2450Mhz	Polarization	Vertical
Temp	26°C	Hum.	57%

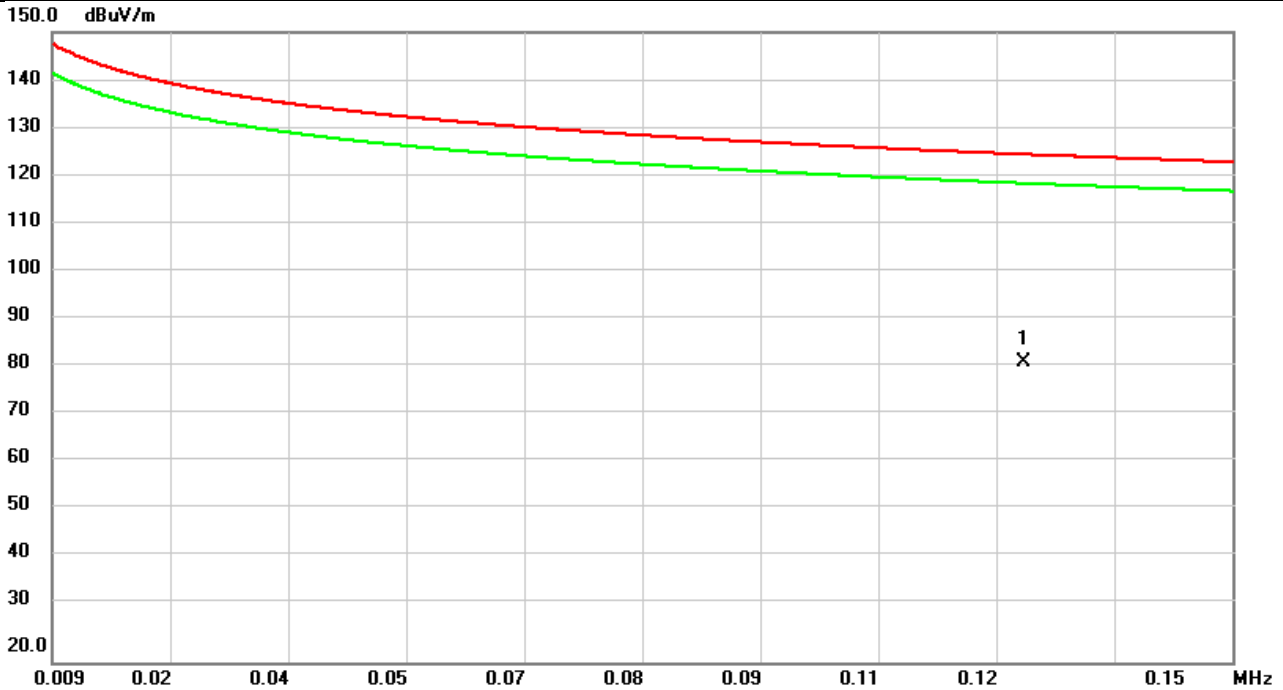

No.	Mk.	Freq.	Reading Level	Correct Factor	Measurement	Limit	Over	Detector	Comment
		MHz	dBuV	dB	dBuV/m	dBuV/m	dB		
1	*	0.1250	66.72	15.12	81.84	124.75	-42.91	AVG	

REMARKS:

- (1) Measurement Value = Reading Level + Correct Factor.
- (2) Margin Level = Measurement Value - Limit Value.

Test Mode	SRD	Test Date	2025/4/2
Test Frequency	2450Mhz	Polarization	Vertical
Temp	26°C	Hum.	57%



No.	Mk.	Freq. MHz	Reading Level dBuV	Correct Factor dB	Measure- ment dBuV/m	Limit dBuV/m	Over dB	Detector	Comment
1		0.2505	29.90	9.60	39.50	118.71	-79.21	AVG	
2		4.4315	19.09	-4.21	14.88	88.62	-73.74	QP	
3		13.5586	14.87	-3.32	11.55	88.62	-77.07	QP	
4		22.3763	23.79	-3.46	20.33	88.62	-68.29	QP	
5	*	24.8767	28.77	-2.97	25.80	88.62	-62.82	QP	
6		26.1265	27.09	-2.73	24.36	88.62	-64.26	QP	

REMARKS:

- (1) Measurement Value = Reading Level + Correct Factor.
- (2) Margin Level = Measurement Value - Limit Value.

Test Mode	SRD	Test Date	2025/4/2
Test Frequency	2450Mhz	Polarization	Horizontal
Temp	26°C	Hum.	57%

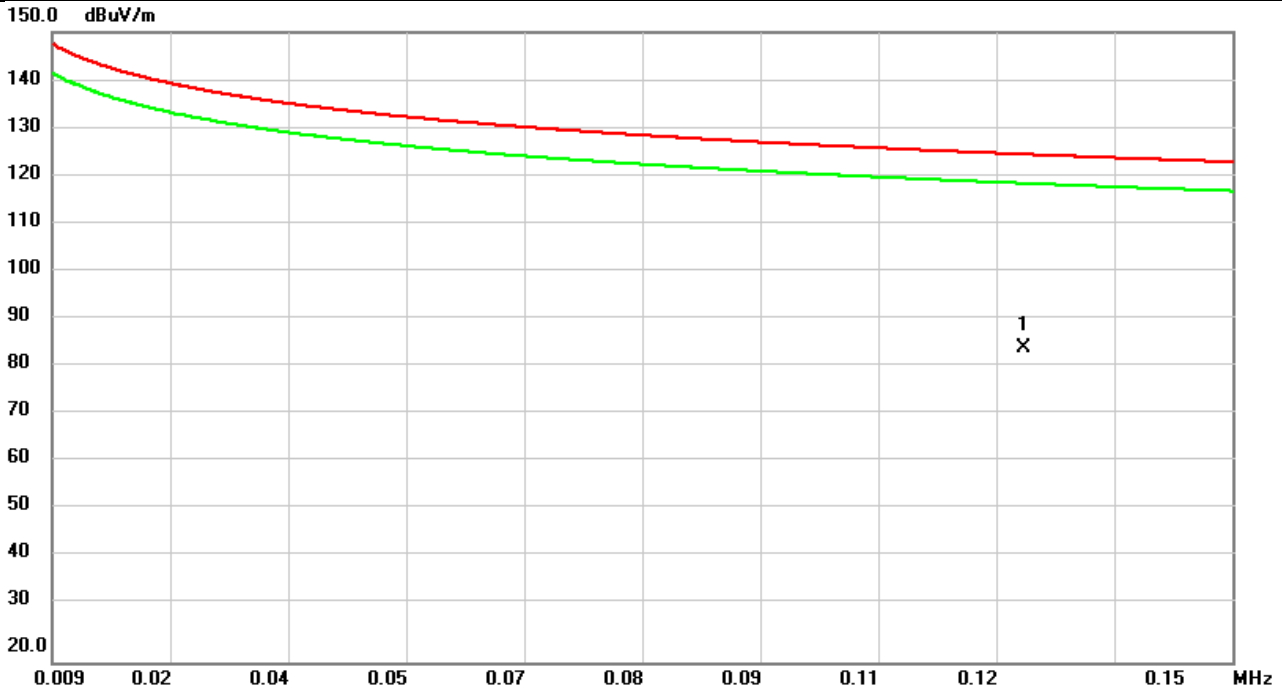

No.	Mk.	Freq.	Reading Level	Correct Factor	Measurement	Limit	Over	Detector	Comment
		MHz	dBuV	dB	dBuV/m	dBuV/m	dB		
1	*	0.1250	69.87	15.12	84.99	124.75	-39.76	AVG	

REMARKS:

- (1) Measurement Value = Reading Level + Correct Factor.
- (2) Margin Level = Measurement Value - Limit Value.

Test Mode	SRD	Test Date	2025/4/2
Test Frequency	2450Mhz	Polarization	Horizontal
Temp	26°C	Hum.	57%

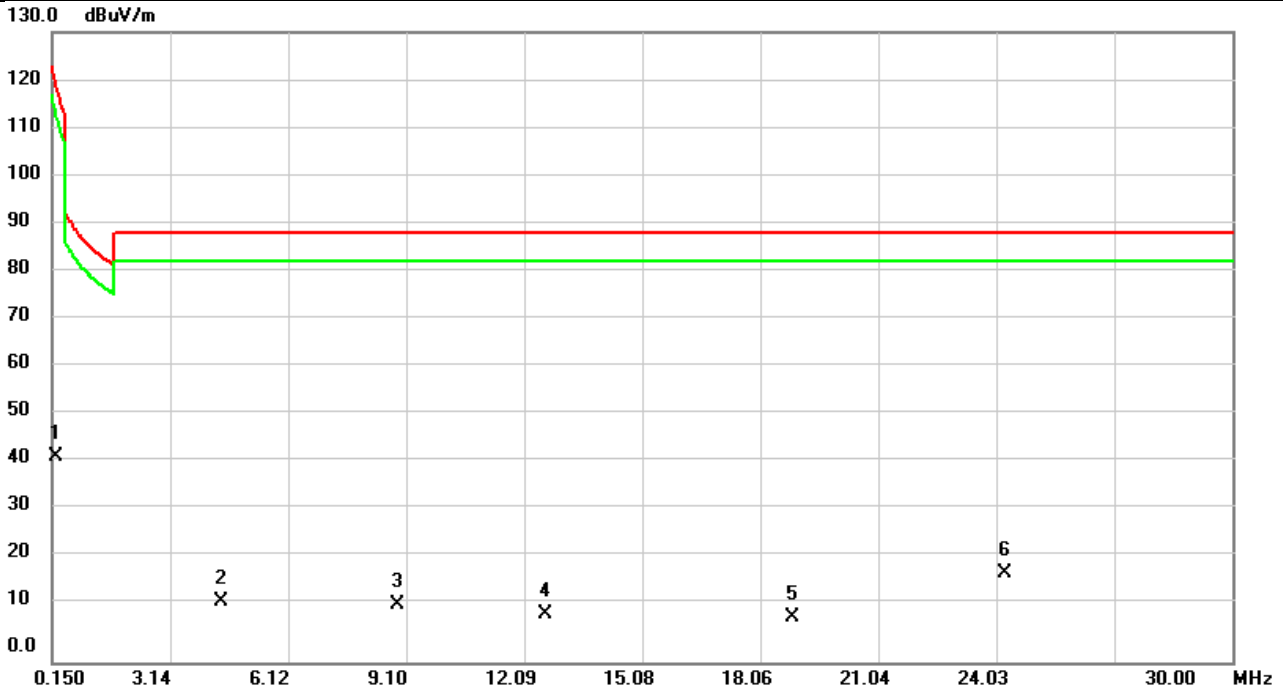

No.	Mk.	Freq.	Reading Level	Correct Factor	Measurement	Limit	Over	Detector	Comment
		MHz	dBuV	dB	dBuV/m	dBuV/m	dB		
1		0.2495	32.71	9.64	42.35	118.74	-76.39	AVG	
2		4.4403	16.73	-4.21	12.52	88.62	-76.10	QP	
3		8.8752	15.12	-3.30	11.82	88.62	-76.80	QP	
4		12.6263	13.22	-3.24	9.98	88.62	-78.64	QP	
5		18.8760	12.99	-3.82	9.17	88.62	-79.45	QP	
6	*	24.2540	21.48	-3.10	18.38	88.62	-70.24	QP	

REMARKS:

- (1) Measurement Value = Reading Level + Correct Factor.
- (2) Margin Level = Measurement Value - Limit Value.

APPENDIX C RADIATED EMISSIONS - 30 MHZ TO 1 GHZ

Test Mode	SRD	Test Date	2025/4/2
Test Frequency	2450Mhz	Polarization	Vertical
Temp	26°C	Hum.	57%

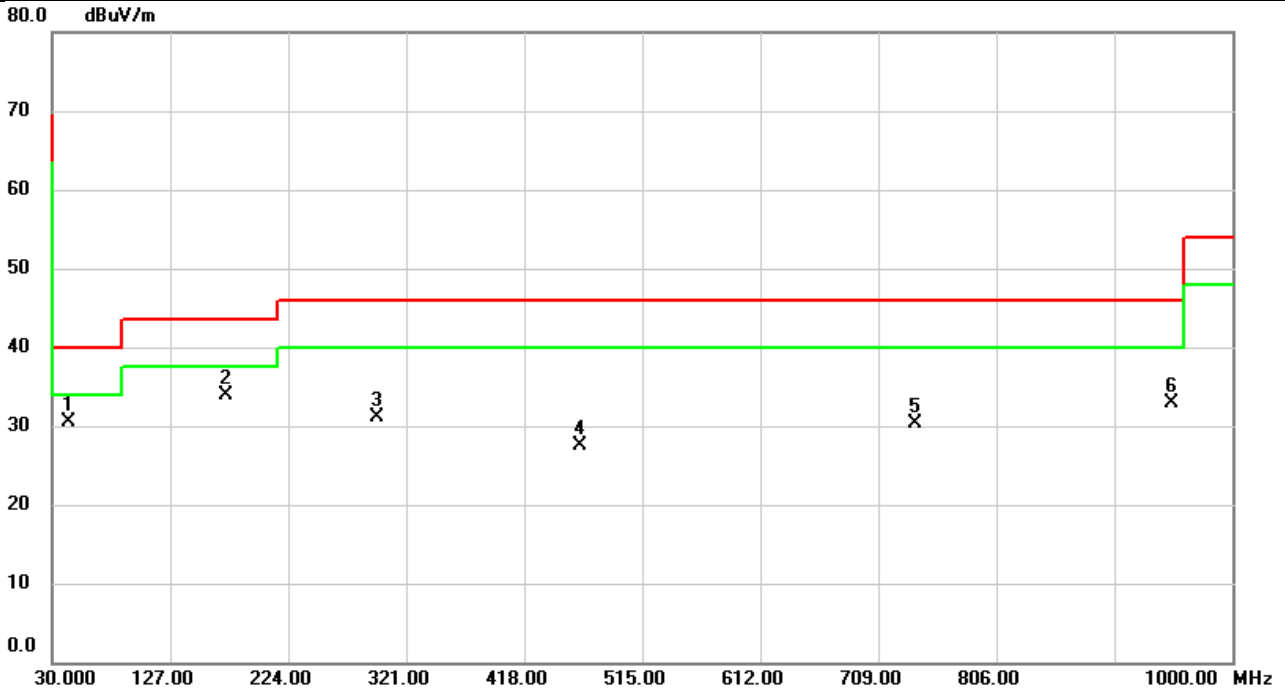

No.	Mk.	Freq.	Reading Level	Correct Factor	Measurement	Limit	Over	Detector	Comment
		MHz	dBuV	dB	dBuV/m	dBuV/m	dB		
1	*	43.6770	42.38	-11.88	30.50	40.00	-9.50	peak	
2		172.4930	46.51	-12.68	33.83	43.50	-9.67	peak	
3		297.0410	42.35	-11.22	31.13	46.00	-14.87	peak	
4		463.5577	34.42	-6.97	27.45	46.00	-18.55	peak	
5		739.1347	32.17	-1.79	30.38	46.00	-15.62	peak	
6		949.7863	31.83	1.12	32.95	46.00	-13.05	peak	

REMARKS:

- (1) Measurement Value = Reading Level + Correct Factor.
- (2) Margin Level = Measurement Value - Limit Value.

Test Mode	SRD	Test Date	2025/4/2
Test Frequency	2450Mhz	Polarization	Horizontal
Temp	26°C	Hum.	57%

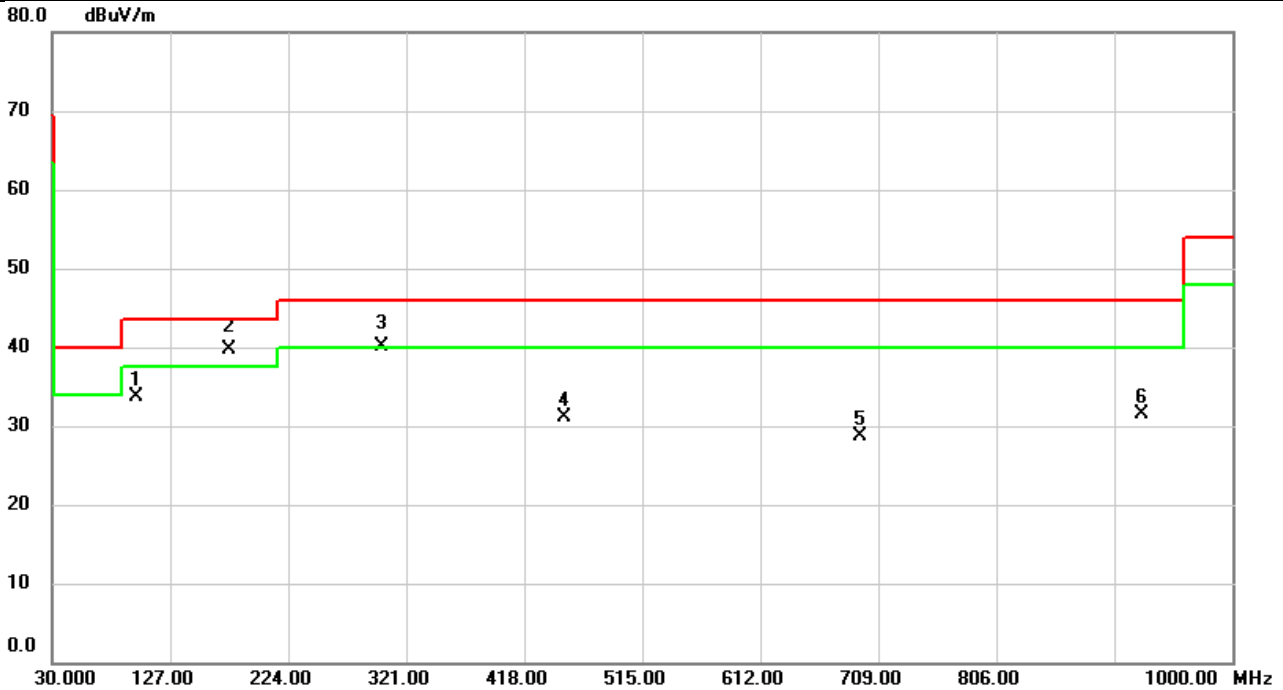

No.	Mk.	Freq.	Reading Level	Correct Factor	Measurement	Limit	Over	Detector	Comment
		MHz	dBuV	dB	dBuV/m	dBuV/m	dB		
1		99.0317	50.50	-16.70	33.80	43.50	-9.70	peak	
2	*	175.3707	52.72	-12.95	39.77	43.50	-3.73	QP	
3	!	300.8887	51.16	-11.11	40.05	46.00	-5.95	QP	
4		450.8830	38.14	-7.12	31.02	46.00	-14.98	peak	
5		694.4823	31.37	-2.70	28.67	46.00	-17.33	peak	
6		924.9867	30.82	0.64	31.46	46.00	-14.54	peak	

REMARKS:

- (1) Measurement Value = Reading Level + Correct Factor.
- (2) Margin Level = Measurement Value - Limit Value.

APPENDIX D RADIATED EMISSIONS - ABOVE 1 GHZ

Test Mode	SRD	Test Date	2025/4/1
Test Frequency	2450MHz	Polarization	Horizontal
Temp	20°C	Hum.	66%

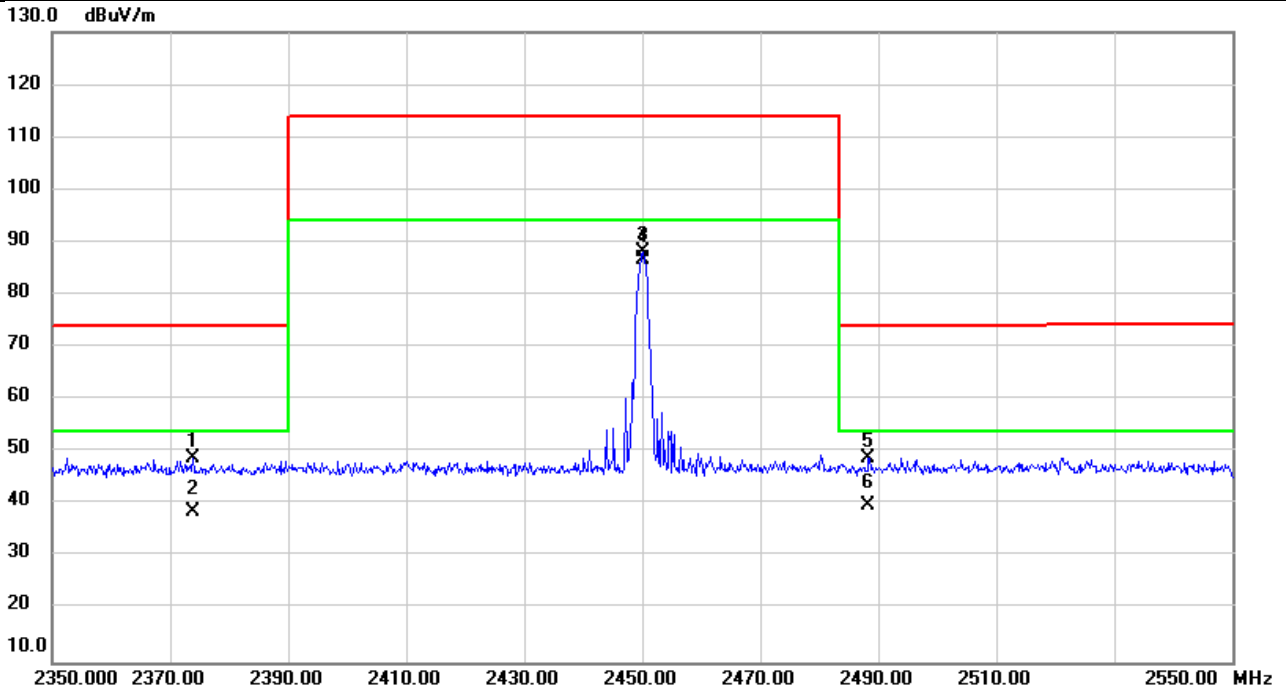

No.	Mk.	Freq.	Reading Level	Correct Factor	Measurement	Limit	Over	Detector	Comment
		MHz	dBuV	dB	dBuV/m	dBuV/m	dB		
1		2373.947	53.17	-4.18	48.99	74.00	-25.01	peak	
2		2373.947	42.97	-4.18	38.79	54.00	-15.21	AVG	
3		2450.000	92.18	-4.09	88.09	114.00	-25.91	peak	NoLimit
4	*	2450.000	90.61	-4.09	86.52	94.00	-7.48	AVG	NoLimit
5		2488.393	52.91	-4.05	48.86	74.03	-25.17	peak	
6		2488.393	43.89	-4.05	39.84	54.01	-14.17	AVG	

REMARKS:

- (1) Measurement Value = Reading Level + Correct Factor.
- (2) Margin Level = Measurement Value - Limit Value.
- (3) Average Correct Factor = 20Log(duty cycle) = 0

Test Mode	SRD	Test Date	2025/4/2
Test Frequency	2450Mhz	Polarization	Vertical
Temp	26°C	Hum.	57%

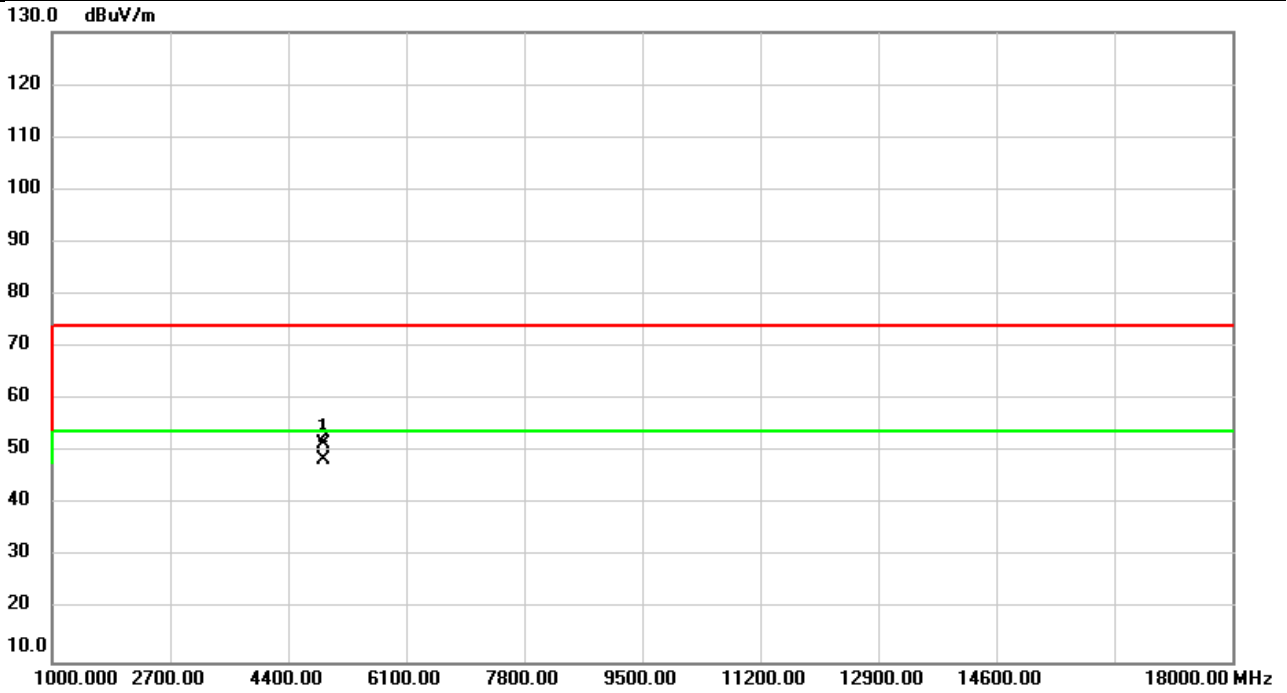

No.	Mk.	Freq.	Reading Level	Correct Factor	Measurement	Limit	Over	Detector	Comment
		MHz	dBuV	dB	dBuV/m	dBuV/m	dB		
1		4900.000	49.35	2.13	51.48	74.00	-22.52	peak	
2	*	4900.000	46.41	2.13	48.54	54.00	-5.46	AVG	

REMARKS:

- (1) Measurement Value = Reading Level + Correct Factor.
- (2) Margin Level = Measurement Value - Limit Value.
- (3) Average Correct Factor = 20Log(duty cycle) = 0

Test Mode	SRD	Test Date	2025/4/2
Test Frequency	2450Mhz	Polarization	Horizontal
Temp	26°C	Hum.	57%

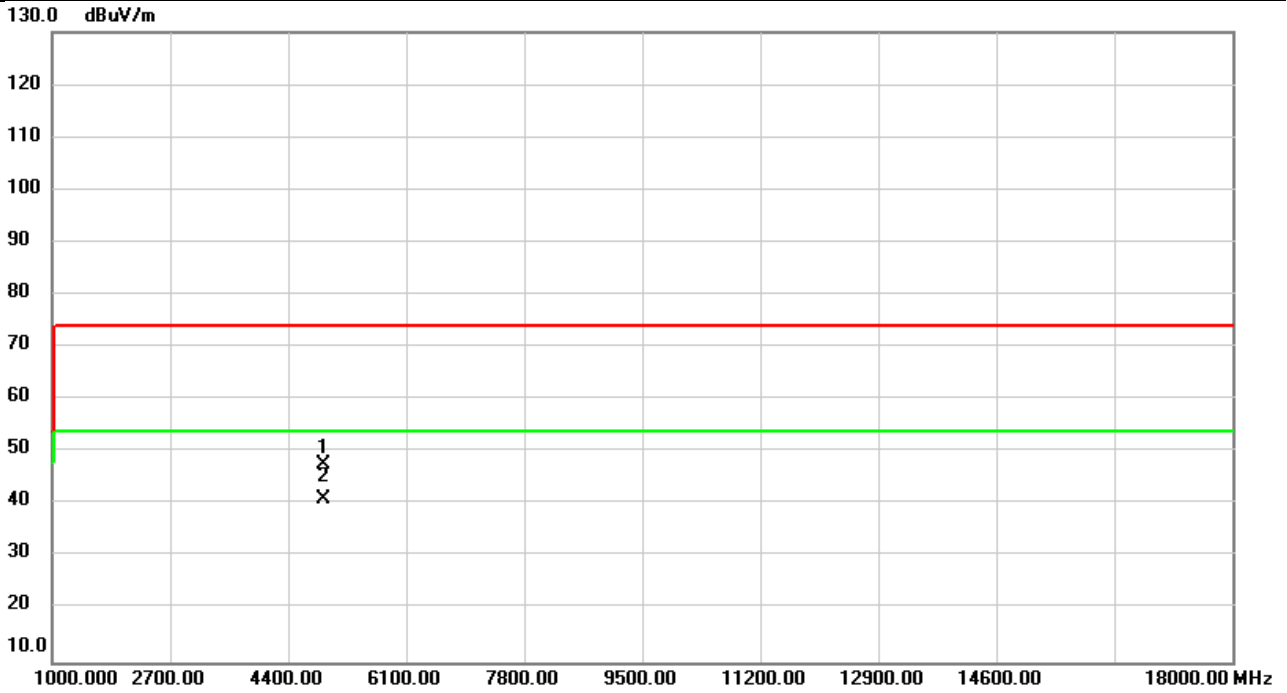

No.	Mk.	Freq. MHz	Reading Level dBuV	Correct Factor dB	Measure- ment dBuV/m	Limit dBuV/m	Over dB	Detector	Comment
1		4900.000	45.55	2.13	47.68	74.00	-26.32	peak	
2	*	4900.000	39.06	2.13	41.19	54.00	-12.81	AVG	

REMARKS:

- (1) Measurement Value = Reading Level + Correct Factor.
- (2) Margin Level = Measurement Value - Limit Value.
- (3) Average Correct Factor = 20Log(duty cycle) = 0

Test Mode	SRD	Test Date	2025/4/2
Test Frequency	2450Mhz	Polarization	Vertical
Temp	26°C	Hum.	57%

130.0 dBuV/m

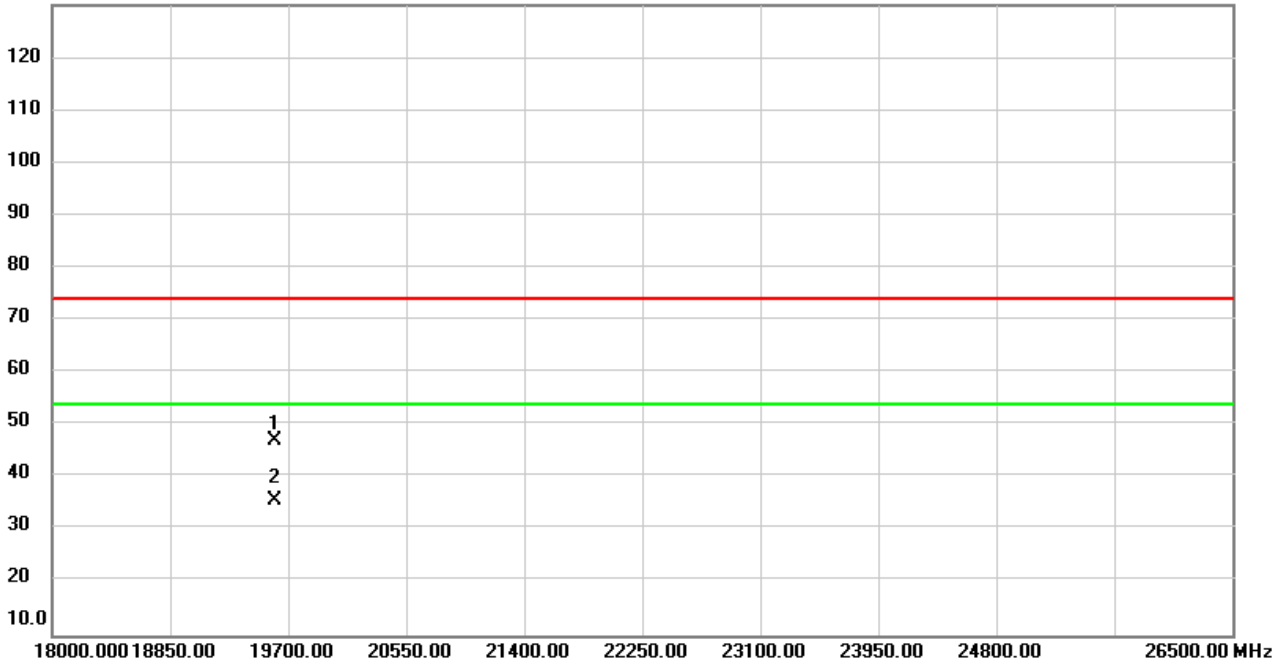

No.	Mk.	Freq. MHz	Reading Level dBuV	Correct Factor dB	Measure- ment dBuV/m	Limit dBuV/m	Over dB	Detector	Comment
1		19600.00	53.13	-5.96	47.17	74.00	-26.83	peak	
2	*	19600.00	41.53	-5.96	35.57	54.00	-18.43	AVG	

REMARKS:

- (1) Measurement Value = Reading Level + Correct Factor.
- (2) Margin Level = Measurement Value - Limit Value.
- (3) Average Correct Factor = 20Log(duty cycle) = 0

Test Mode	SRD	Test Date	2025/3/13
Test Frequency	2450Mhz	Polarization	Horizontal
Temp	26°C	Hum.	57%

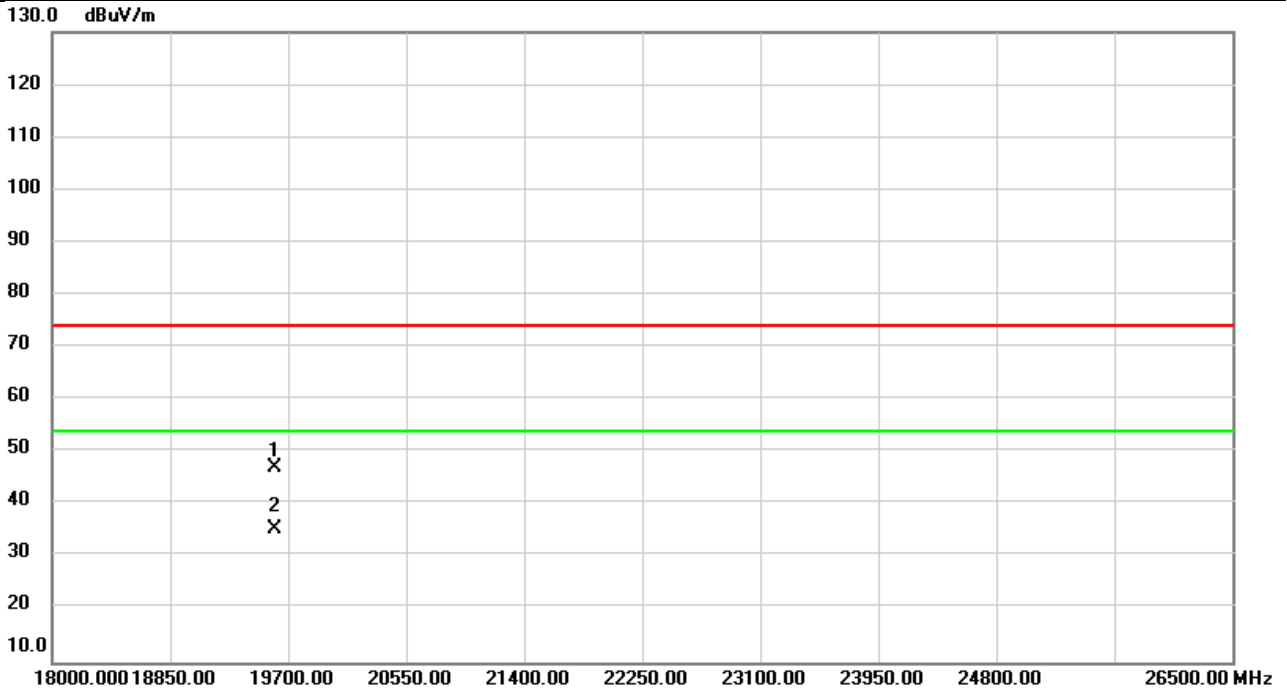

No.	Mk.	Freq. MHz	Reading Level dBuV	Correct Factor dB	Measure- ment dBuV/m	Limit dBuV/m	Over dB	Detector	Comment
1		19600.00	53.09	-5.96	47.13	74.00	-26.87	peak	
2	*	19600.00	41.43	-5.96	35.47	54.00	-18.53	AVG	

REMARKS:

- (1) Measurement Value = Reading Level + Correct Factor.
- (2) Margin Level = Measurement Value - Limit Value.
- (3) Average Correct Factor = 20Log(duty cycle) = 0

APPENDIX E BANDWIDTH

Test Mode: SRD

Frequency (MHz)	20dB Bandwidth (MHz)	99% Occupied BW (MHz)
2450	1.16	1.64

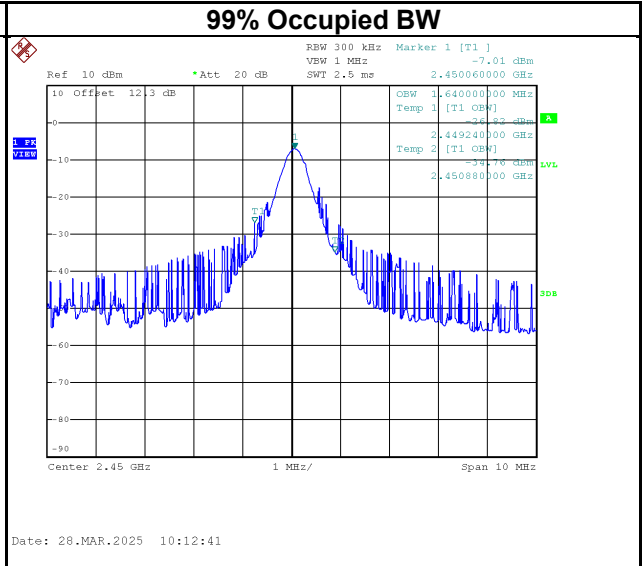
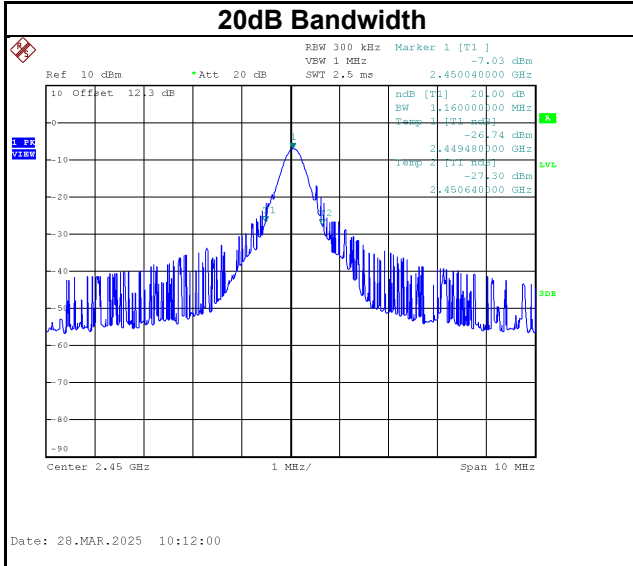

End of Test Report