



# FCC Report

**Application Purpose** : Original grant  
**Applicant Name:** : Jiangxi Jade IOT-Sensing Technology Co., Ltd  
**FCC ID** : 2ALRU-JD-GP11  
**Equipment Type** : Control Panel  
**Model Name** : JD-GP11  
**Report Number** : FCC17030205A-1  
**Standard(S)** : FCC Part 15 Subpart C  
**Date Of Receipt** : March 24, 2017  
**Date Of Issue** : May 09, 2017

**Test By** :   
\_\_\_\_\_  
(Dekun Liu)

**Reviewed By** :   
\_\_\_\_\_  
(Sol Qin)

**Authorized by** :   
\_\_\_\_\_  
(Michal Ling)

**Prepared by** : **QTC Certification & Testing Co., Ltd.**  
2nd Floor,B1 Buiding,Fengyeyuan Industrial Plant,,Liuxian  
2st.Road,Xin'an Street,Bao'an District,,Shenzhen,  
518000China.  
Registration Number: 588523

<b>REPORT REVISE RECORD</b>				
<b>Report Version</b>	<b>Revise Time</b>	<b>Issued Date</b>	<b>Valid Version</b>	<b>Notes</b>
V1.0	/	May 09, 2017	Valid	Original Report

<b>Table of Contents</b>	<b>Page</b>
<b>1. GENERAL INFORMATION</b>	<b>5</b>
<b>2. TEST DESCRIPTION</b>	<b>7</b>
<b>2.1 MEASUREMENT UNCERTAINTY</b>	<b>7</b>
<b>2.2 DESCRIPTION OF TEST MODES</b>	<b>8</b>
<b>2.3 CONFIGURATION OF SYSTEM UNDER TEST</b>	<b>9</b>
<b>2.4 DESCRIPTION OF SUPPORT UNITS</b>	<b>9</b>
<b>3. SUMMARY OF TEST RESULTS</b>	<b>10</b>
<b>4. MEASUREMENT INSTRUMENTS</b>	<b>11</b>
<b>5. EMC EMISSION TEST</b>	<b>13</b>
<b>5.1 CONDUCTED EMISSION MEASUREMENT</b>	<b>13</b>
5.1.1 POWER LINE CONDUCTED EMISSION LIMITS (FREQUENCY RANGE 150KHZ-30MHZ)	13
5.1.2 TEST PROCEDURE	14
5.1.3 DEVIATION FROM TEST STANDARD	14
5.1.4 TEST SETUP	14
5.1.5 EUT OPERATING CONDITIONS	14
5.1.6 TEST RESULTS	15
<b>5.2 RADIATED EMISSION MEASUREMENT</b>	<b>17</b>
5.2.1 RADIATED EMISSION LIMITS	17
5.2.2 TEST PROCEDURE	18
5.2.3 DEVIATION FROM TEST STANDARD	18
5.2.4 TEST SETUP	19
5.2.5 EUT OPERATING CONDITIONS	20
<b>5.2.6 TEST RESULTS</b>	<b>21</b>
<b>5.3 TRANSMIT TIME</b>	<b>24</b>
5.3.1 AUTOMATICALLY LIMITING OPERATION LIMITS	24
5.3.2 TEST PROCEDURE	24
5.3.3 DEVIATION FROM TEST STANDARD	24
5.3.4 TEST SETUP	24
5.3.5 EUT OPERATING CONDITIONS	24
5.3.6 TEST RESULTS	24
<b>5.4 OCCUPIED BANDWIDTH</b>	<b>26</b>
5.4.1 LIMITS OF BAND	26
5.4.3 TEST PROCEDURE	26
5.4.4 TEST SETUP	26
5.4.5 TEST RESULT	26
<b>6. ANTENNA REQUIREMENT</b>	<b>28</b>

**Table of Contents**

**Page**

**7. EUT TEST PHOTO**

**29**

**8. PHOTOGRAPHS OF EUT**

**31**

## 1. GENERAL INFORMATION

Test Model	JD-GP11
Applicant	Jiangxi Jade IOT-Sensing Technology Co., Ltd
Address	Jade Industrial Park,Gantong Street No.109,Ganzhou economic development district,Ganzhou City,Jiangxi Province,China.
Manufacturer	Jiangxi Jade IOT-Sensing Technology Co., Ltd
Address	Jade Industrial Park,Gantong Street No.109,Ganzhou economic development district,Ganzhou City,Jiangxi Province,China.
Equipment Type	Control Panel
Brand Name	JADE
Hardware version:	V1.0
Software version:	V1.0
Extreme Temp. Tolerance	-10°C--+55°C
Battery information:	Lithium ion batteries : JG 953450-28 Capacity:1800mAh Voltage: 7.4V
Adapter Information:	Adapter: LY012SPS-120100UH Input: AC 100~240V 50/60Hz 0.35A Output: DC 12V---1A
Operating Frequency	433.92±0.5MHz
Channels	1
Channel Spacing	N/A
Modulation Type	2ASK
Version	N/A
Antenna Type:	Integral Antenna
Antenna gain:	3dBi
Data of receipt	March 24, 2017
Date of test	March 24, 2017 to May 09, 2017
Deviation	None
Condition of Test Sample	Normal

**We hereby certify that:**

All measurement facilities used to collect the measurement data are located at QTC Certification & Testing Co., Ltd.

Registration Number: 588523

The data evaluation, test procedures, and equipment configurations shown in this report were made in accordance with the procedures given in ANSI C 63.10:2013. The sample tested as described in this report is in compliance with the FCC Rules Part15 Subpart C.

The test results of this report relate only to the tested sample identified in this report.

## 2. TEST DESCRIPTION

### 2.1 MEASUREMENT UNCERTAINTY

The reported uncertainty of measurement  $y \pm U$ , where expanded uncertainty  $U$  is based on a standard uncertainty multiplied by a coverage factor of  $k=2$ , providing a level of confidence of approximately **95** %.

No.	Item	Uncertainty
1	Conducted Emission Test	$\pm 3.2$ dB
2	RF power, conducted	$\pm 0.16$ dB
3	Spurious emissions, conducted	$\pm 0.21$ dB
4	All emissions, radiated(<1G)	$\pm 4.7$ dB
5	All emissions, radiated(>1G)	$\pm 4.7$ dB
6	Temperature	$\pm 0.5$ °C
7	Humidity	$\pm 2$ %

## 2.2 DESCRIPTION OF TEST MODES

To investigate the maximum EMI emission characteristics generates from EUT, the test system was pre-scanning tested base on the consideration of following EUT operation mode or test configuration mode which possible have effect on EMI emission level. Each of these EUT operation mode(s) or test configuration mode(s) mentioned above was evaluated respectively.

<b>For Conducted Emission</b>	
Final Test Mode	Description
Mode 1	Transmitter

<b>For Radiated Emission</b>	
Final Test Mode	Description
Mode 1	Transmitter



## 2.3 CONFIGURATION OF SYSTEM UNDER TEST

Mode 1

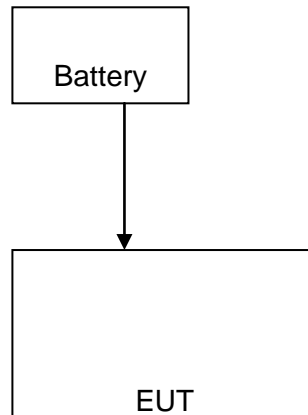

(EUT: Emergency button)

I/O Port of EUT			
I/O Port Type	Q'TY	Cable	Tested with
/	/	/	/
/	/	/	/

## 2.4 DESCRIPTION OF SUPPORT UNITS

The EUT has been tested as an independent unit together with other necessary accessories or support units. The following support units or accessories were used to form a representative test configuration during the tests.

Item	Equipment	Mfr/Brand	Model/Type No.	Series No.	Note
1	/	/	/	/	/
2	/	/	/	/	/
3	/	/	/	/	/

Note:

- (1) The support equipment was authorized by Declaration of Confirmation.
- (2) For detachable type I/O cable should be specified the length in cm in 『Length』 column.

### 3. SUMMARY OF TEST RESULTS

Test procedures according to the technical standards:

FCC Part15 , Subpart C			
Standard Section	Test Item	Judgment	Remark
15.207	Conducted Emission	PASS	
15.209 ,15.231(e)	Radiated Emission	PASS	
Section 15.231(e)	Transmit time	PASS	
Section 15.231(c)	Occupied Bandwidth	PASS	
15.203	Antenna Requirement	PASS	

NOTE:

(1) "N/A" denotes test is not applicable in this test report.

## 4. MEASUREMENT INSTRUMENTS

NAME OF EQUIPMENT	MANUFACTURER	MODEL	SERIAL NUMBER	Calibration Date	Calibration Due.
EMI Test Receiver	R&S	ESCI	100005	08/19/2016	08/18/2017
LISN	AFJ	LS16	16010222119	08/19/2016	08/18/2017
LISN(EUT)	Mestec	AN3016	04/10040	08/19/2016	08/18/2017
Universal Radio Communication Tester	R&S	CMU 200	1100.0008.02	08/19/2016	08/18/2017
Coaxial cable	Megalon	LMR400	N/A	08/12/2016	08/11/2017
GPIB cable	Megalon	GPIB	N/A	08/12/2016	08/11/2017
Spectrum Analyzer	R&S	FSU	100114	08/19/2016	08/18/2017
Pre Amplifier	H.P.	HP8447E	2945A02715	10/13/2016	10/12/2017
Pre-Amplifier	CDSI	PAP-1G18-38	--	10/13/2016	10/12/2017
Bi-log Antenna	SUNOL Sciences	JB3	A021907	09/13/2016	09/12/2017
9*6*6 Anechoic	--	--	--	08/21/2016	08/20/2017
Horn Antenna	COMPLIANCE ENGINEERING	CE18000	--	09/13/2016	09/12/2017
Horn Antenna	SCHWARZBECK	BBHA9120D	9120D-631	08/23/2016	08/22/2017
Cable	TIME MICROWAVE	LMR-400	N-TYPE04	04/25/2016	04/24/2017
System-Controller	CCS	N/A	N/A	N.C.R	N.C.R
Turn Table	CCS	N/A	N/A	N.C.R	N.C.R
Antenna Tower	CCS	N/A	N/A	N.C.R	N.C.R
RF cable	Murata	MXHQ87WA3000	-	08/21/2016	08/20/2017
Loop Antenna	EMCO	6502	00042960	08/22/2016	08/21/2017
Horn Antenna	SCHWARZBECK	BBHA 9170	1123	08/19/2016	08/18/2017
Power meter	Anritsu	ML2487A	6K00003613	08/23/2016	08/22/2017
Power sensor	Anritsu	MX248XD	--	08/19/2016	08/18/2017

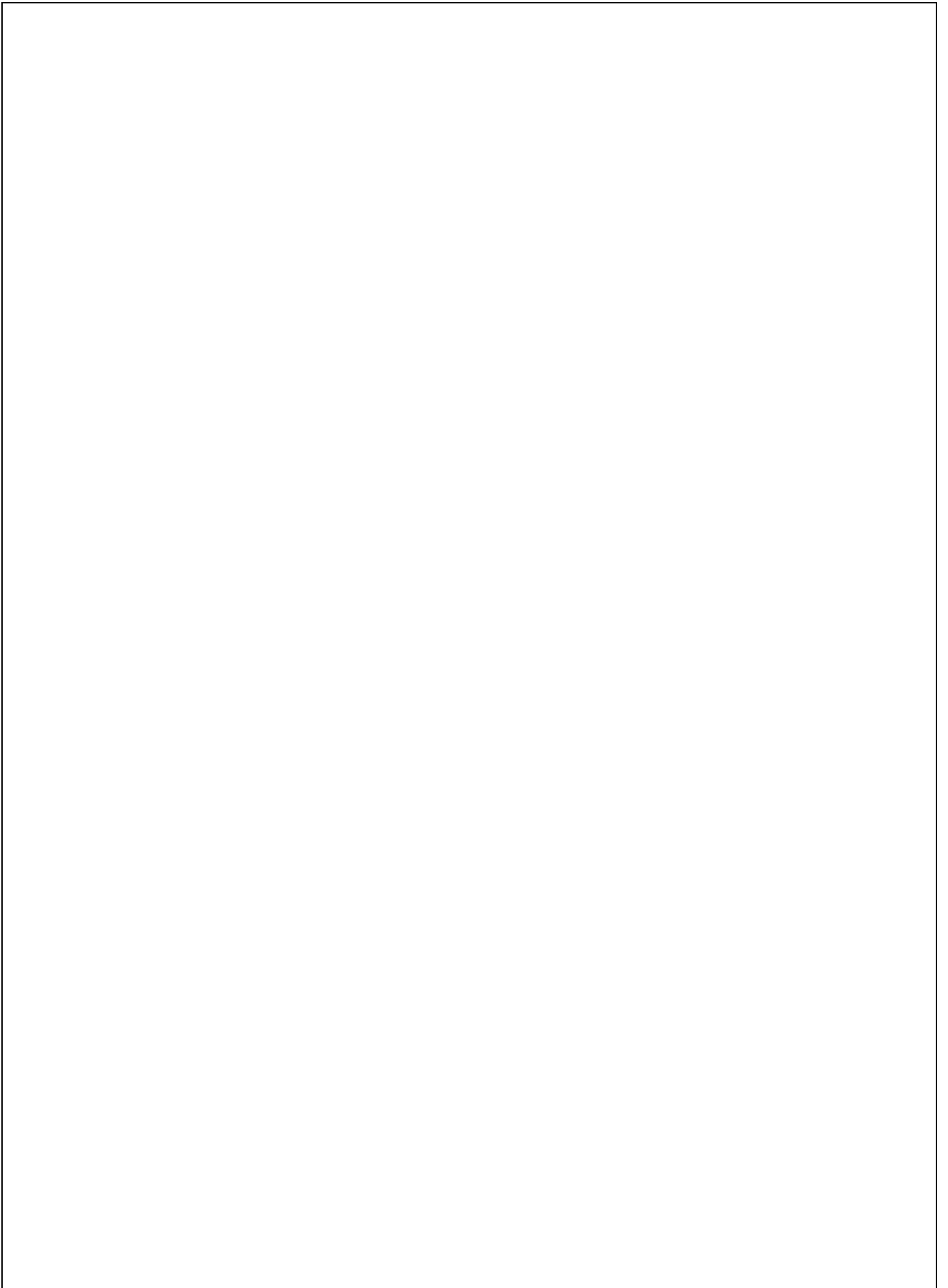

# 5. EMC EMISSION TEST

## 5.1 CONDUCTED EMISSION MEASUREMENT

### 5.1.1 POWER LINE CONDUCTED EMISSION Limits (Frequency Range 150KHz-30MHz)

FREQUENCY (MHz)	Class A (dBuV)		Class B (dBuV)		Standard
	Quasi-peak	Average	Quasi-peak	Average	
0.15 -0.5	79.00	66.00	66 - 56 *	56 - 46 *	FCC
0.50 -5.0	73.00	60.00	56.00	46.00	FCC
5.0 -30.0	73.00	60.00	60.00	50.00	FCC

Note:

- (1) The tighter limit applies at the band edges.
- (2) The limit of " \* " marked band means the limitation decreases linearly with the logarithm of the frequency in the range.

The following table is the setting of the receiver

Receiver Parameters	Setting
Attenuation	10 dB
Start Frequency	0.15 MHz
Stop Frequency	30 MHz
IF Bandwidth	9 kHz

### 5.1.2 TEST PROCEDURE

- The EUT was placed 0.4 meters from the horizontal ground plane with EUT being connected to the power mains through a line impedance stabilization network (LISN). All other support equipments powered from additional LISN(s). The LISN provide 50 Ohm/ 50uH of coupling impedance for the measuring instrument.
- Interconnecting cables that hang closer than 40 cm to the ground plane shall be folded back and forth in the center forming a bundle 30 to 40 cm long.
- I/O cables that are not connected to a peripheral shall be bundled in the center. The end of the cable may be terminated, if required, using the correct terminating impedance. The overall length shall not exceed 1 m.
- LISN at least 80 cm from nearest part of EUT chassis.
- For the actual test configuration, please refer to the related Item –EUT Test Photos.

### 5.1.3 DEVIATION FROM TEST STANDARD

No deviation

### 5.1.4 TEST SETUP

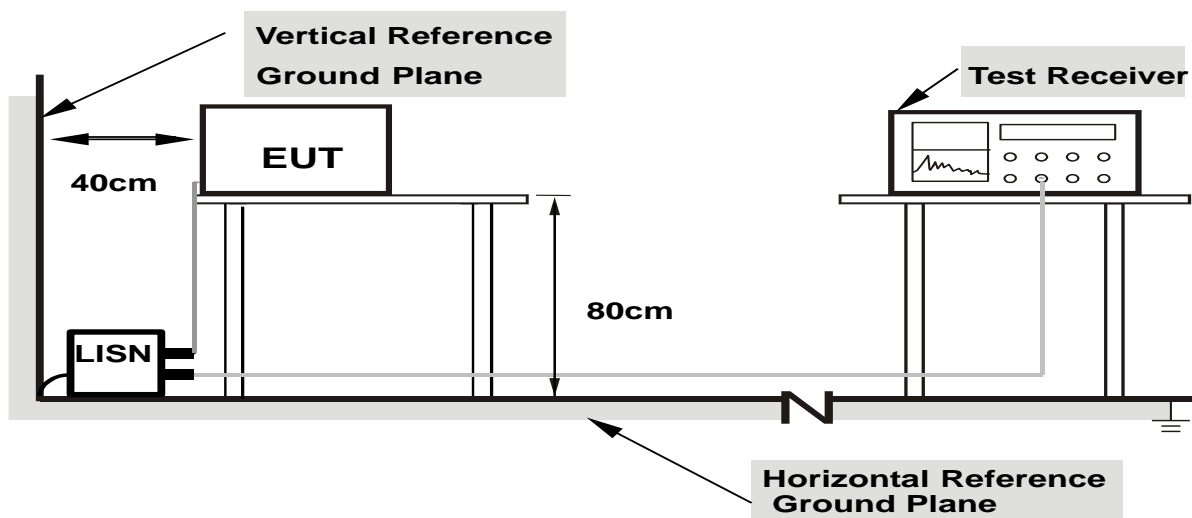

- Note: 1.Support units were connected to second LISN.**  
**2.Both of LISNs (AMN) are 80 cm from EUT and at least 80 from other units and other metal planes**

### 5.1.5 EUT OPERATING CONDITIONS

The EUT was configured for testing in a typical fashion (as a customer would normally use it). The EUT has been programmed to continuously transmit during test. This operating condition was tested and used to collect the included data.

## 5.1.6 TEST RESULTS

EUT	Control Panel	Model Name	JD-GP11
Temperature	26 °C	Relative Humidity	54%
Pressure	1010hPa	Phase	L
Voltage	120V/60Hz	Test Mode	Mode 1

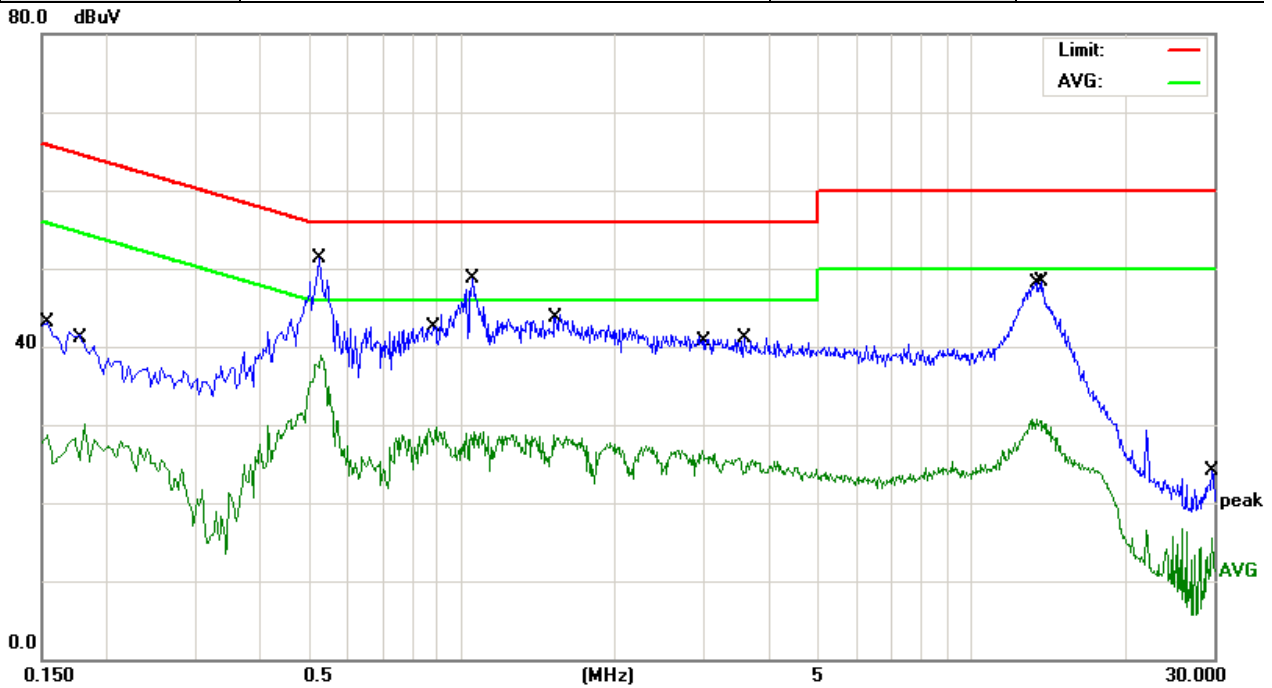

No.	Mk.	Freq. MHz	Reading Level dBuV	Correct Factor dB	Measure- ment dBuV	Limit dBuV	Over dB	Detector
1		0.1539	31.17	11.85	43.02	65.78	-22.76	QP
2		0.1819	18.65	11.46	30.11	54.39	-24.28	AVG
3	*	0.5260	40.57	10.80	51.37	56.00	-4.63	QP
4		0.5299	28.06	10.80	38.86	46.00	-7.14	AVG
5		0.8900	18.98	10.68	29.66	46.00	-16.34	AVG
6		1.0500	38.14	10.63	48.77	56.00	-7.23	QP
7		1.5180	18.08	10.60	28.68	46.00	-17.32	AVG
8		2.9739	16.15	10.57	26.72	46.00	-19.28	AVG
9		3.6020	30.50	10.56	41.06	56.00	-14.94	QP
10		13.4700	20.11	10.59	30.70	50.00	-19.30	AVG
11		13.7860	37.67	10.59	48.26	60.00	-11.74	QP
12		29.7700	13.51	10.68	24.19	60.00	-35.81	QP

Remark: All the modes have been investigated, and only worst mode is presented in this report.

EUT	Control Panel	Model Name	JD-GP11
Temperature	26 °C	Relative Humidity	54%
Pressure	1010hPa	Phase	N
Voltage	120V/60Hz	Test Mode	Mode 1

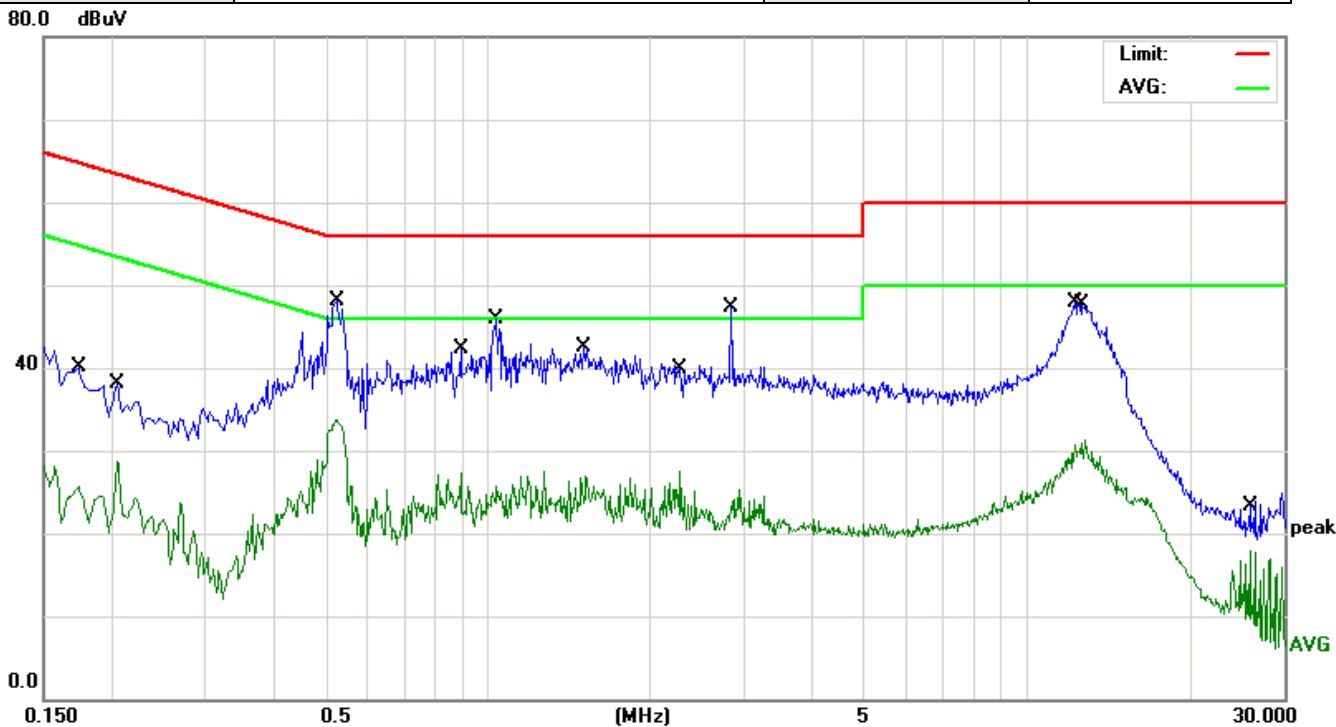

No.	Mk.	Freq. MHz	Reading Level dBuV	Correct Factor dB	Measure- ment dBuV	Limit dBuV	Over dB	Detector
1		0.1740	28.44	11.57	40.01	64.76	-24.75	QP
2		0.2060	17.54	11.19	28.73	53.36	-24.63	AVG
3		0.5220	22.90	10.80	33.70	46.00	-12.30	AVG
4	*	0.5260	37.21	10.80	48.01	56.00	-7.99	QP
5		0.8900	16.60	10.68	27.28	46.00	-18.72	AVG
6		1.0420	35.33	10.63	45.96	56.00	-10.04	QP
7		1.5100	31.98	10.60	42.58	56.00	-13.42	QP
8		2.2820	16.93	10.58	27.51	46.00	-18.49	AVG
9		2.8380	36.65	10.57	47.22	56.00	-8.78	QP
10		12.2580	37.31	10.58	47.89	60.00	-12.11	QP
11		12.8380	20.76	10.60	31.36	50.00	-18.64	AVG
12		25.8779	7.23	10.60	17.83	50.00	-32.17	AVG

Remark: All the modes have been investigated, and only worst mode is presented in this report.



## 5.2 RADIATED EMISSION MEASUREMENT

### 5.2.1 RADIATED EMISSION LIMITS (Frequency Range 9kHz-1000MHz)

The emissions from an intentional radiator shall not exceed the field strength levels specified in the following table:

(b) In addition to the provisions of §15.205, the field strength of emissions from intentional radiators operated under this section shall not exceed the following:

Fundamental frequency (MHz)	Field strength of fundamental (microvolts/meter)	Field strength of spurious emissions (microvolts/meter)
40.66-40.70	2,250	225
70-130	1,250	125
130-174	<sup>1</sup> 1,250 to 3,750	<sup>1</sup> 125 to 375
174-260	3,750	375
260-470	<sup>1</sup> 3,750 to 12,500	<sup>1</sup> 375 to 1,250
Above 470	12,500	1,250

#### LIMITS OF RADIATED EMISSION MEASUREMENT (Above 1000MHz)

FREQUENCY (MHz)	Limit (dBuV/m) (at 3M)	
	PEAK	AVERAGE
Above 1000	74	54

Notes:

- (1) The limit for radiated test was performed according to FCC PART 15C.
- (2) The tighter limit applies at the band edges.
- (3) Emission level (dBuV/m)=20log Emission level (uV/m).

Spectrum Parameter	Setting
Attenuation	Auto
Start Frequency	1000 MHz
Stop Frequency	10th carrier harmonic
RB / VB (emission in restricted band)	1 MHz / 1 MHz for Peak, 1 MHz / 10Hz for Average

Receiver Parameter	Setting
Attenuation	Auto
Start ~ Stop Frequency	9kHz~150kHz / RB 200Hz for QP
Start ~ Stop Frequency	150kHz~30MHz / RB 9kHz for QP
Start ~ Stop Frequency	30MHz~1000MHz / RB 120kHz for QP

**5.2.2 TEST PROCEDURE**

- a. The measuring distance of at 3 m shall be used for measurements at frequency up to 1GHz. For frequencies above 1GHz, any suitable measuring distance may be used.
- b. The EUT was placed on the top of a rotating table 0.8 meters above the ground at a 3 meter open area test site. The table was rotated 360 degrees to determine the position of the highest radiation.
- c. The height of the equipment or of the substitution antenna shall be 0.8 m; the height of the test antenna shall vary between 1 m to 4 m. Both horizontal and vertical polarizations of the antenna are set to make the measurement.
- d. The initial step in collecting conducted emission data is a spectrum analyzer peak detector mode pre-scanning the measurement frequency range. Significant peaks are then marked and then Quasi Peak detector mode re-measured.
- e. If the Peak Mode measured value compliance with and lower than Quasi Peak Mode Limit, the EUT shall be deemed to meet QP Limits and then no additional QP Mode measurement performed.
- f. For the actual test configuration, please refer to the related Item –EUT Test Photos.

Note:

***Both horizontal and vertical antenna polarities were tested  
And performed pretest to three orthogonal axis. The worst case emissions were reported***

**5.2.3 DEVIATION FROM TEST STANDARD**

No deviation

## 5.2.4 TEST SETUP

### (A) Radiated Emission Test-Up Frequency Below 30MHz

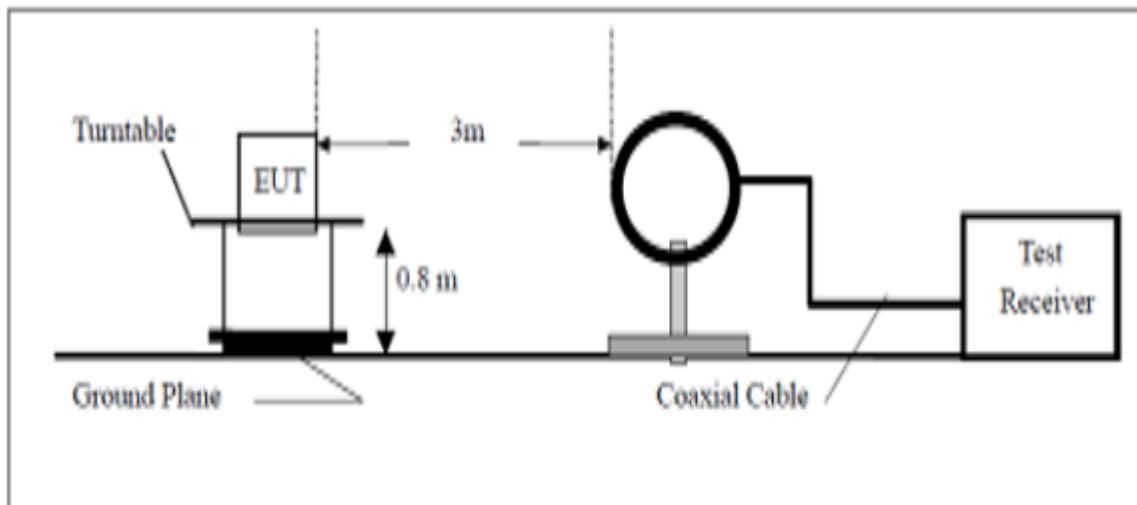

### (B) Radiated Emission Test-Up Frequency 30MHz~1GHz

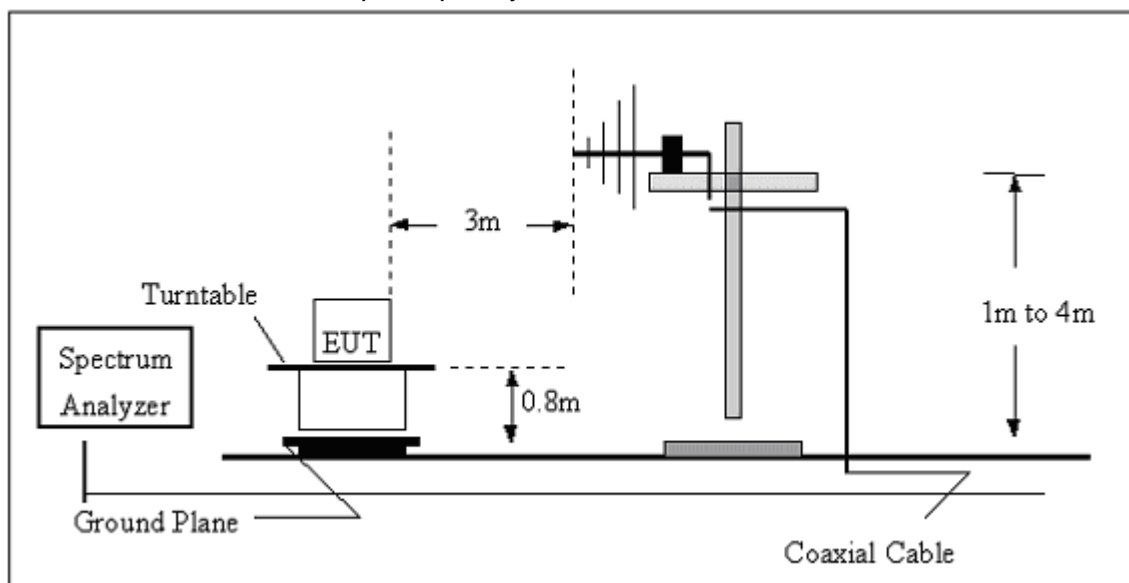

## (C) Radiated Emission Test-Up Frequency Above 1GHz

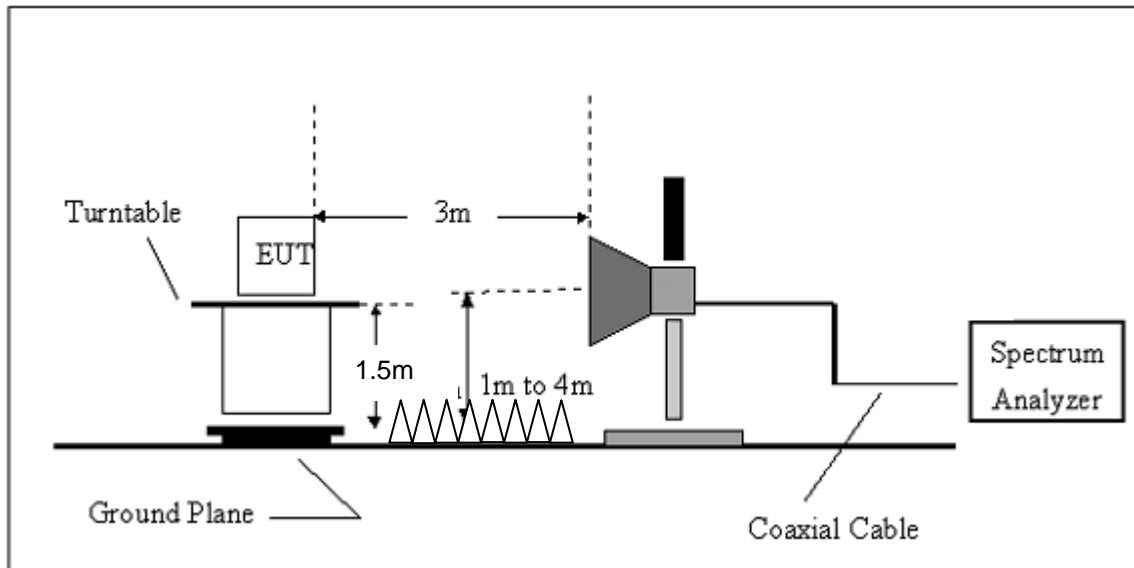
**5.2.5 EUT OPERATING CONDITIONS**

The EUT tested system was configured as the statements of 2.2 Unless otherwise a special operating condition is specified in the follows during the testing.

**5.2.6 TEST RESULTS**

**Field strength of the transmitter at its**

Freq. (MHz)	Horizontal/Vertical	Emission (dBuV/m) PK
433.92	Horizontal	81.41
433.92	Vertical	81.17

**Radiated Emission Data (Frequency from 30MHz to 1GHz)**

EUT	Control Panel	Model Name	JD-GP11
Temperature	20 °C	Relative Humidity	48%
Pressure	1010 hPa	Polarization :	Horizontal
Test Mode	Mode 1	Test Date	April 20, 2017

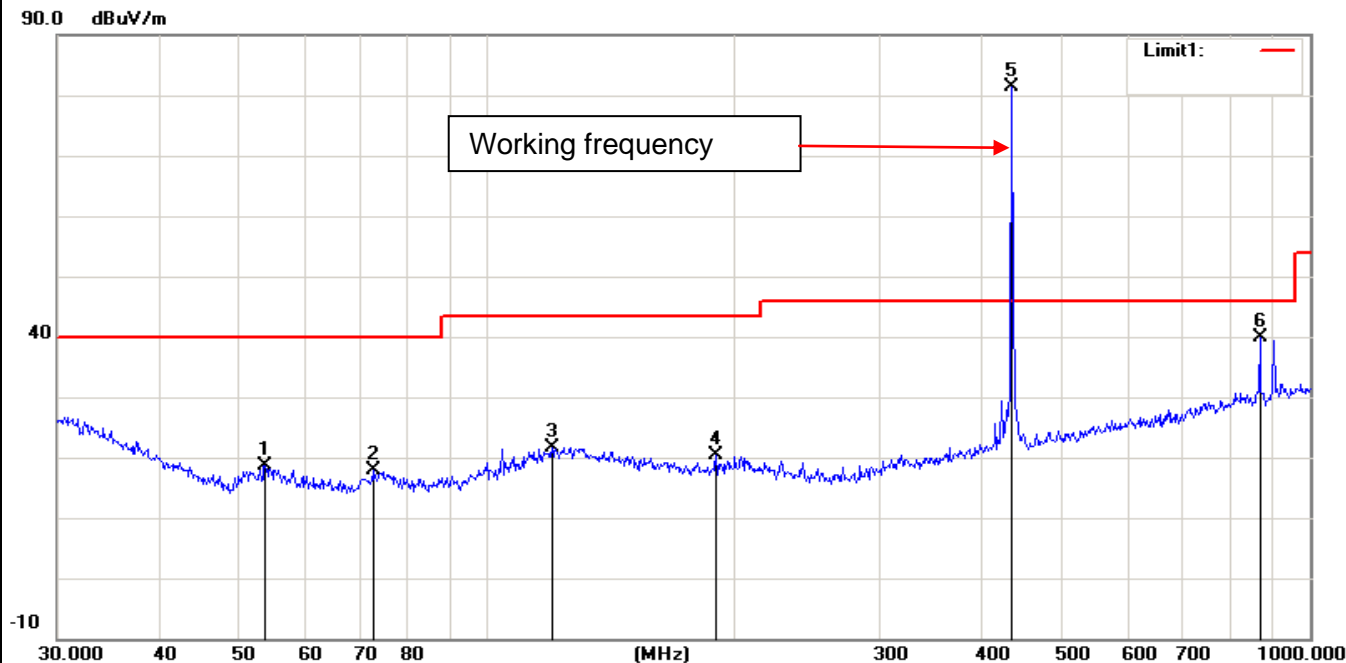

No.	Mk.	Freq. MHz	Reading Level dBuV	Correct Factor dB	Measurement dBuV/m	Limit dBuV/m	Over dB	Detector
1		53.6932	28.02	-9.37	18.65	40.00	-21.35	peak
2		72.5916	25.56	-7.67	17.89	40.00	-22.11	peak
3		119.8556	24.03	-2.33	21.70	43.50	-21.80	peak
4		189.7385	25.55	-5.28	20.27	43.50	-23.23	peak
5	*	434.0651	83.80	-2.39	81.41	46.00	35.41	peak
6		869.1301	35.06	4.89	39.95	46.00	-6.05	peak

Remark: All the modes have been investigated, and only worst mode is presented in this report.

EUT	Control Panel	Model Name	JD-GP11
Temperature	20 °C	Relative Humidity	48%
Pressure	1010 hPa	Polarization :	Vertical
Test Mode	Mode 1	Test Date	April 20, 2017

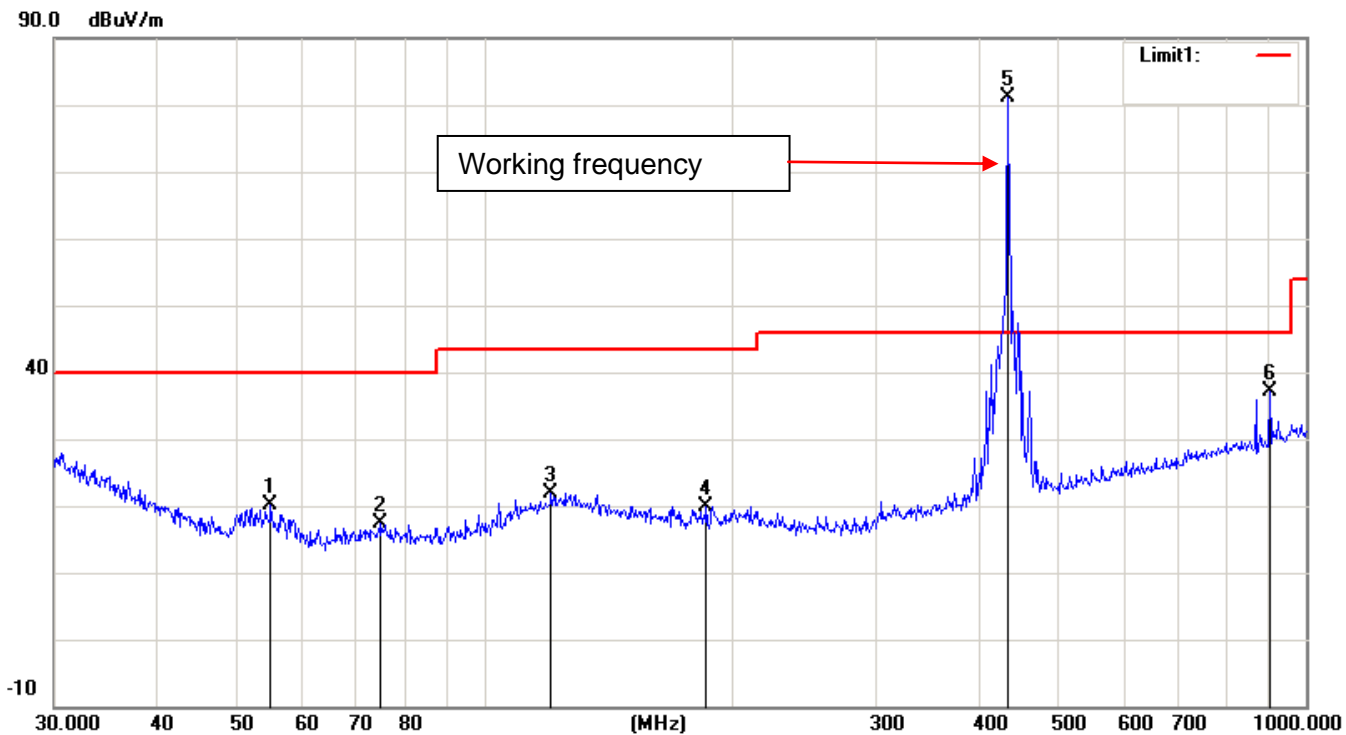

No.	Mk.	Freq. MHz	Reading Level dBuV	Correct Factor dB	Measure- ment dBuV/m	Limit dBuV/m	Over dB	Detector
1		55.0274	29.53	-9.50	20.03	40.00	-19.97	peak
2		74.9191	24.95	-7.53	17.42	40.00	-22.58	peak
3		120.6991	24.24	-2.29	21.95	43.50	-21.55	peak
4		186.4409	25.18	-5.27	19.91	43.50	-23.59	peak
5	*	434.0651	83.56	-2.39	81.17	46.00	35.17	peak
6		903.3093	31.30	5.91	37.21	46.00	-8.79	peak

Remark: All the modes have been investigated, and only worst mode is presented in this report.

**B. Radiated Emission Data (Frequency above 1GHz)**

EUT	Control Panel	Model Name	JD-GP11
Temperature	20 °C	Relative Humidity	48%
Pressure	1010 hPa	Test Mode	Mode 1
Test Date	April 20, 2017		

Freq. (MHz)	Ant. Pol.	Emission Level(dBuV)		Limit 3m(dBuV/m)		Over(dB)	
		PK	AV	PK	AV	PK	AV
1652.14	V	59.21	39.51	74	54	-14.79	-14.49
2829.30	V	58.96	40.40	74	54	-15.04	-13.60
1698.66	H	58.17	39.85	74	54	-15.83	-14.15
2814.16	H	59.03	40.03	74	54	-14.97	-13.97

**Remark:**

1.All emissions not reported were more than 20dB below the specified limit or in the noise floor.

Factor = Antenna Factor + Cable Loss – Pre-amplifier.

2.All the x/y/z orientation has been investigated, and only worst case is presented in this report.

3.Limit is given in the average value (AV) limit, and peak detection method is used in test detection (PK), according to Section 15.231

4.If average emission measurements are employed, the provisions in §15.35 for averaging pulse d emissions and for limiting peak emissions apply. Therefore:

$$\text{Emission\_AV} = \text{Emission\_PK} + \text{AV Factor}$$

$$\text{AV Factor} = 20 \lg(\text{The duration of one cycle}) / (\text{Effective period of the cycle})$$

Acroding to section 5.3 of this report, the one pluse dwell time is longer then 100ms,so the duty cycle is consider to be 1,AV Factor =0.

## 5.3 TRANSMIT TIME

### 5.3.1 AUTOMATICALLY LIMITING OPERATION Limits

**Regulation 15.231 (e)** In addition, devices operated under the provisions of this paragraph shall be provided with a means for automatically limiting operation so that the duration of each transmission shall not be greater than one second and the silent period between transmissions shall be at least 30 times the duration of the transmission but in no case less than 10 seconds.

### 5.3.2 TEST PROCEDURE

The EUT was directly connected to the spectrum analyzer and antenna output port as show in the block diagram below.

- Set span to 0 Hz.
- Set RBW = 100kHz.
- Set VBW  $\geq 3 \times$  RBW.
- Sweep time = 29S.
- Detector = Peak.

### 5.3.3 DEVIATION FROM TEST STANDARD

No deviation

### 5.3.4 TEST SETUP

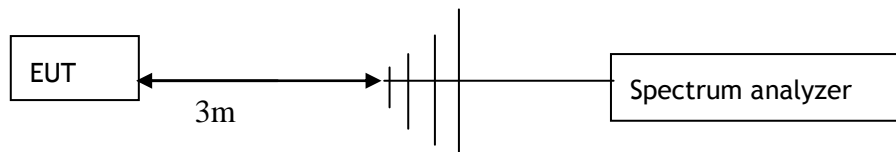

### 5.3.5 EUT OPERATING CONDITIONS

The EUT was configured for testing in a typical function (as a customer would normally use it). This operating condition was tested and used to collect the included data.

### 5.3.6 TEST RESULTS

Ton/Toff (s)	Ton/Toff limits(s)	Result
0.744	Ton<1	Pass
22.680	T <sub>off</sub> >30Ton	Pass





RBW 100 kHz      Marker 2 [T1]      96.19 dBμV  
\* VBW 300 kHz      25.235577 s  
Ref 112 dBμV      \* Att 0 dB      SWT 29 s

1 PK  
VIEW

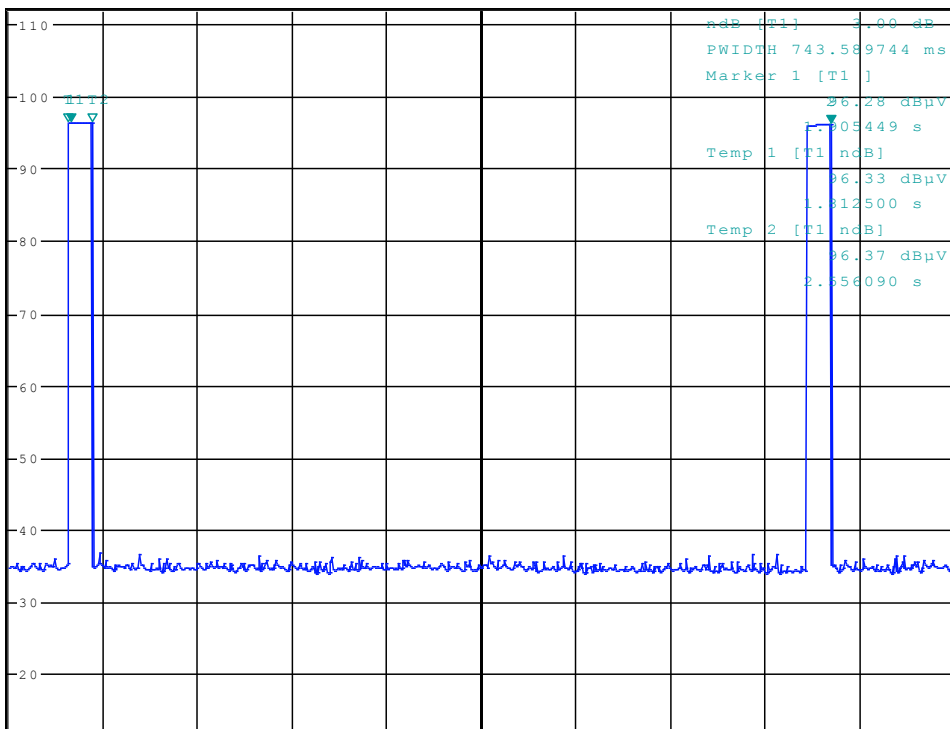

Center 433.92 MHz      2.9 s/

Date: 9.MAY.2017 10:39:42

## 5.4 OCCUPIED BANDWIDTH

### 5.4.1 LIMITS OF BAND

The bandwidth of the emission shall be no wider than 0.25% of the center frequency for device operating above 70MHz and below 900MHz.

### 5.4.3 TEST PROCEDURE

The EUT was placed on a turn table was 0.8meter above ground.

The signal was coupled to the specturm analyzer through an antenna.

Set SPA RBW:10KHz,VBW:30KHz sweep time :auto

Set SPA trace max hold,then view.

### 5.4.4 TEST SETUP

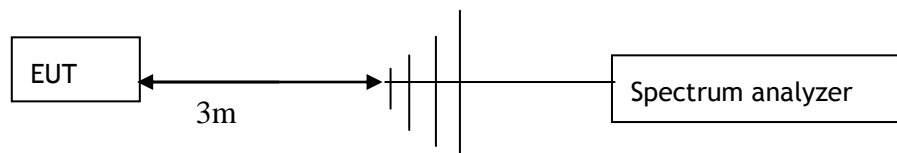

### 5.4.5 TEST RESULT

Frequency (MHz)	20dB bandwidth (KHz)	Maximum Limit (KHz)	Result
433.92	76	1084.8	Pass

Details please see the following test plots.



Ref 110 dBμV      \*Att 10 dB      \*RBW 10 kHz      Marker 1 [T1]      79.70 dBμV  
SWT 20 ms      433.915993590 MHz

1 PR  
VIEW

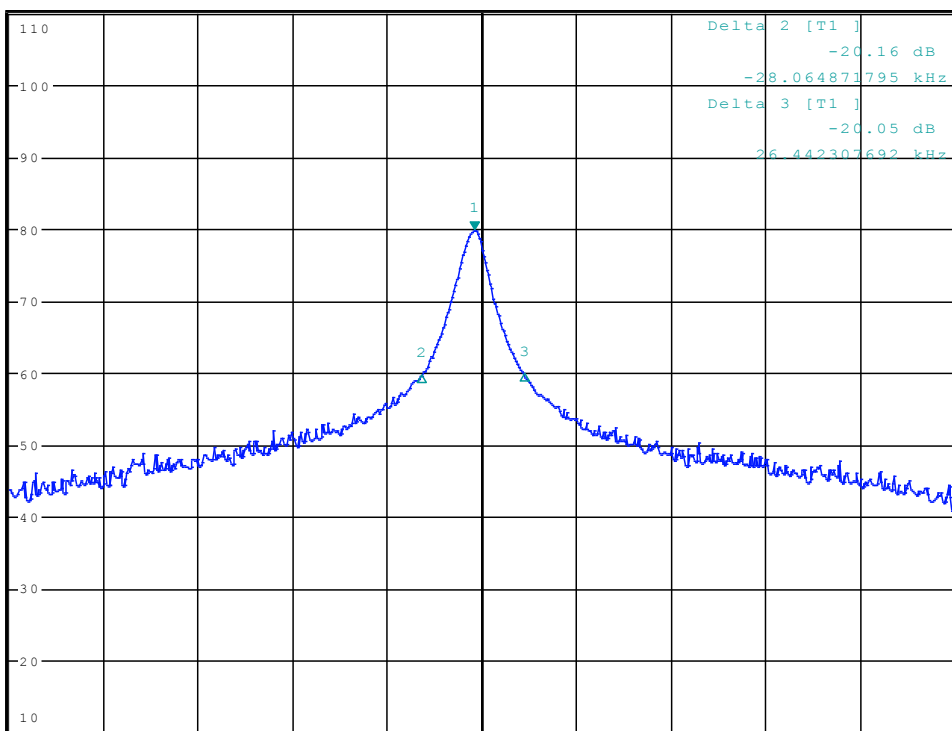

Center 433.92 MHz      50 kHz/      Span 500 kHz

Date: 8.APR.2017 09:30:23

# 6. Antenna Requirement

## 6.1 Antenna requirement

The EUT's antenna is met the requirement of FCC part 15C section 15.203.

## 6.2 Result

The antenna used in this product is an integrated antenna, The antenna's gain is 3dBi and meets the requirement.

## 7. EUT TEST PHOTO

CONDUCTED EMISSION TEST



RADIATED EMISSION TEST  
(Frequency from 30MHz to 1GHz)

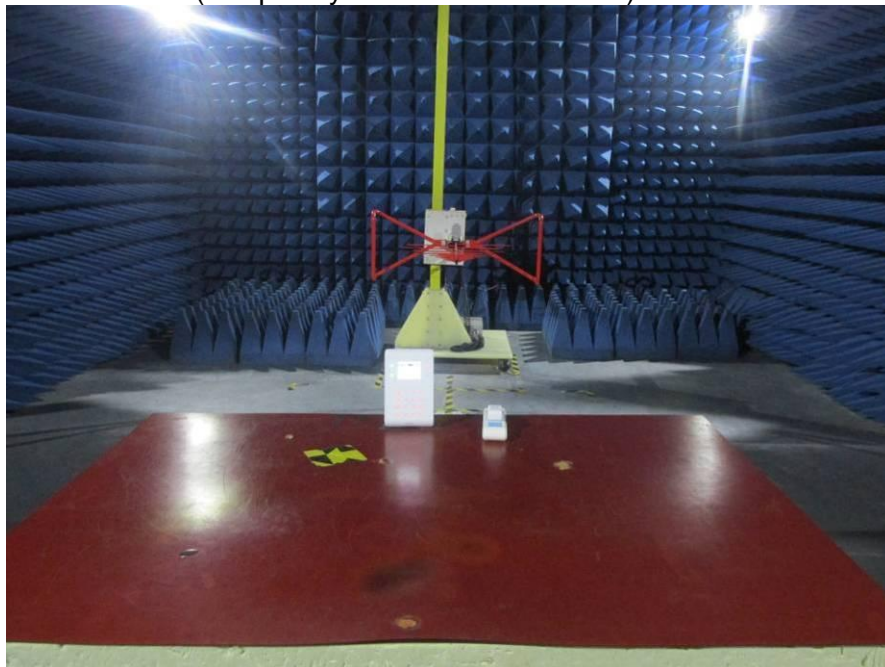

RADIATED EMISSION TEST  
(Frequency above 1GHz)





## 8. PHOTOGRAPHS OF EUT

Appearance photograph of EUT



Appearance photograph of EUT



Appearance photograph of EUT



Appearance photograph of EUT





Appearance photograph of EUT



Appearance photograph of EUT



Appearance photograph of EUT



Appearance photograph of EUT





Internal photograph of EUT



Internal photograph of EUT

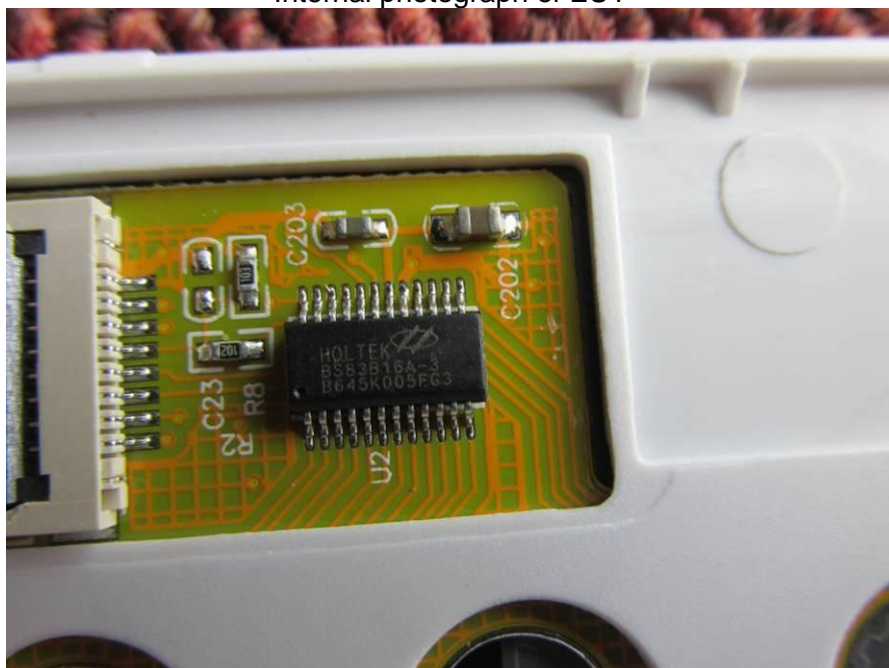

Internal photograph of EUT

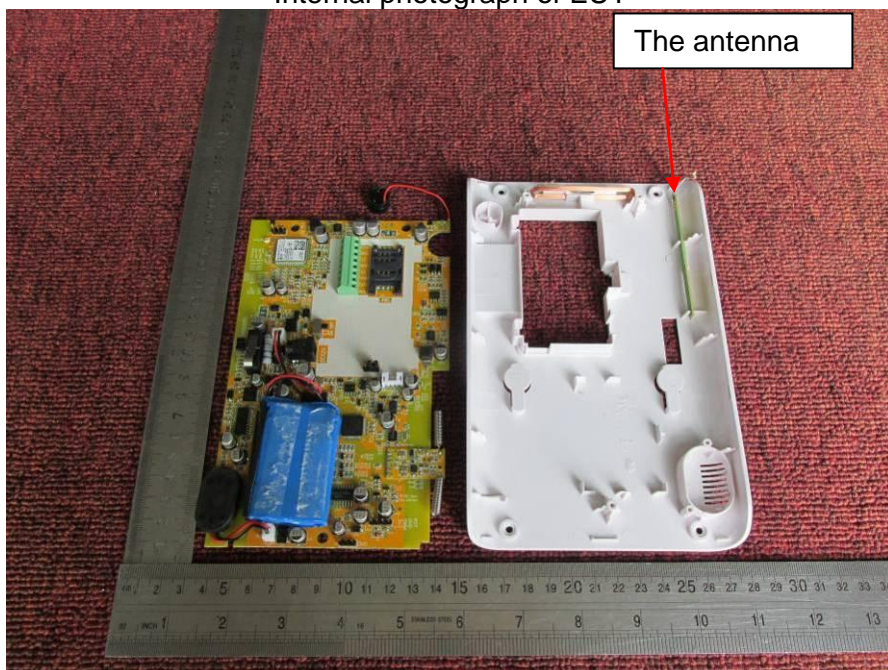

Internal photograph of EUT





Internal photograph of EUT



Internal photograph of EUT





Internal photograph of EUT

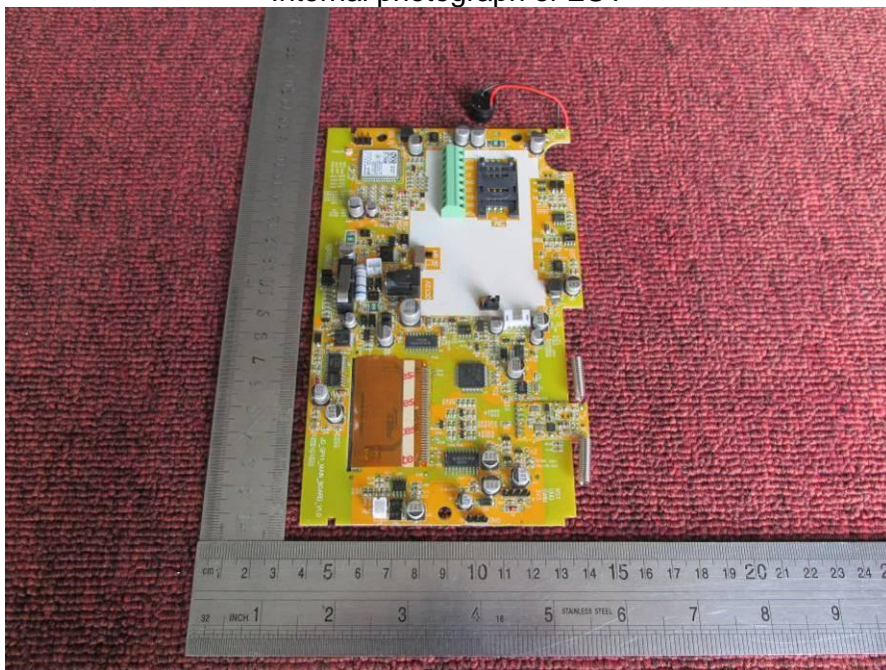

Internal photograph of EUT

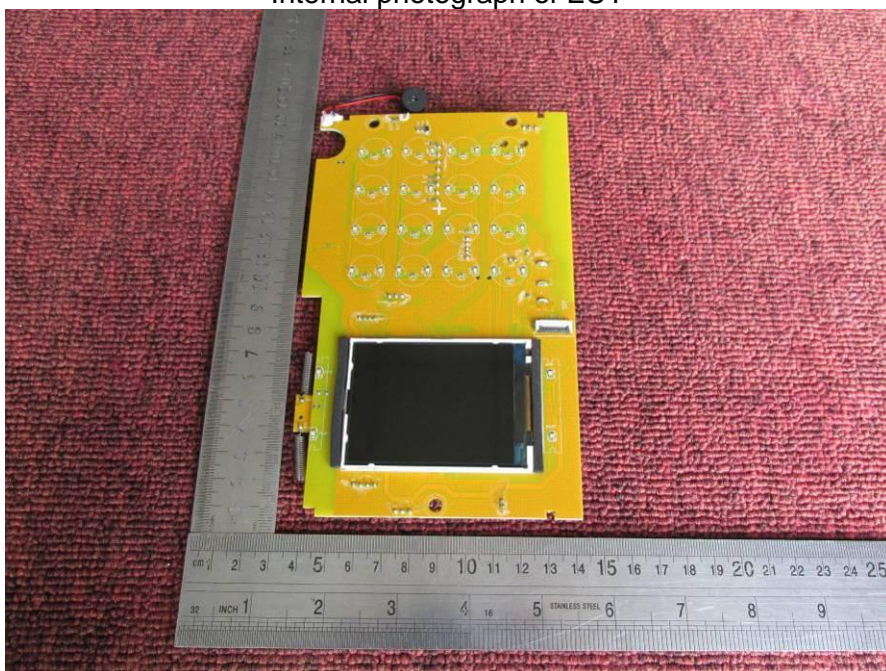

Internal photograph of EUT

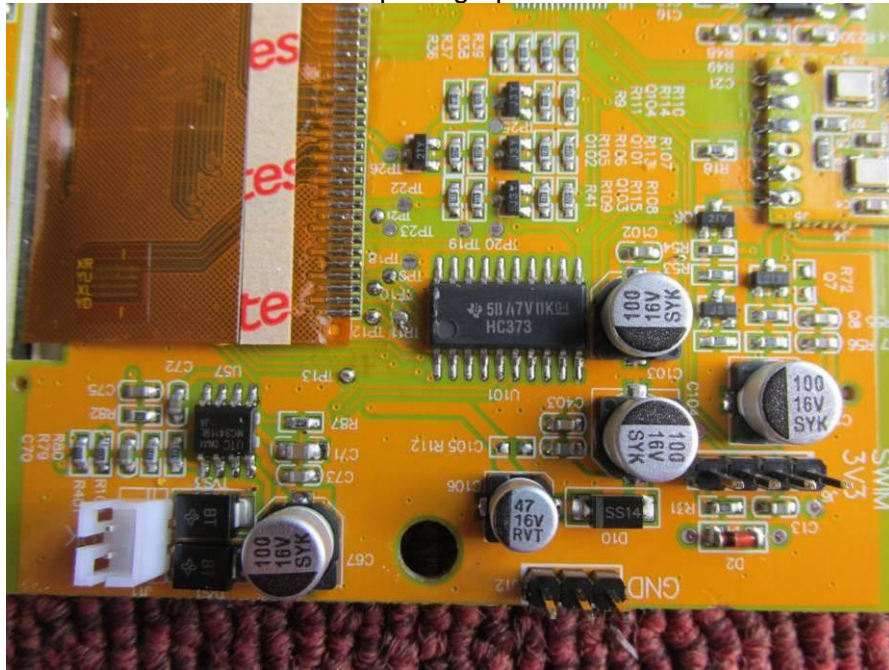

Internal photograph of EUT

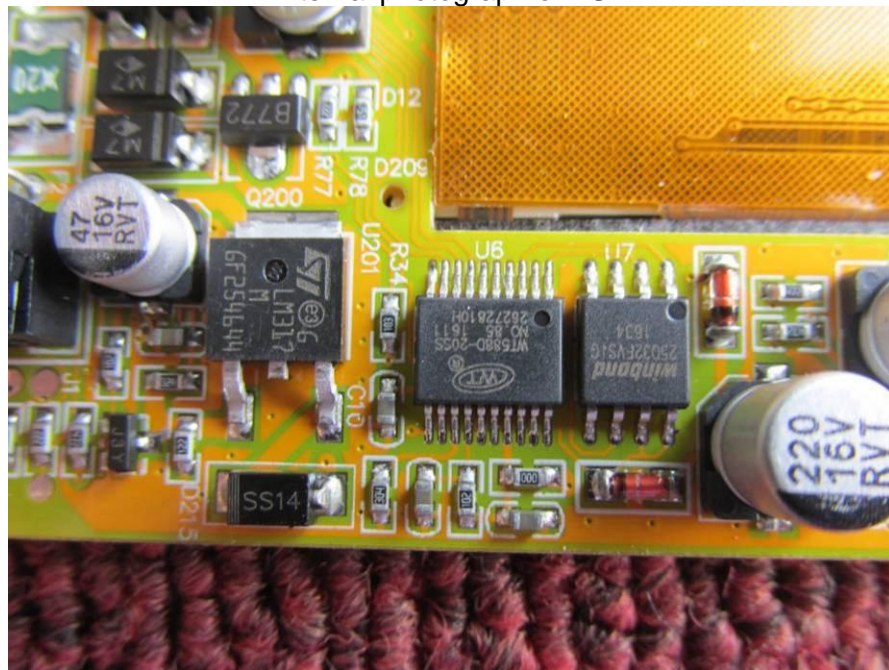



Internal photograph of EUT

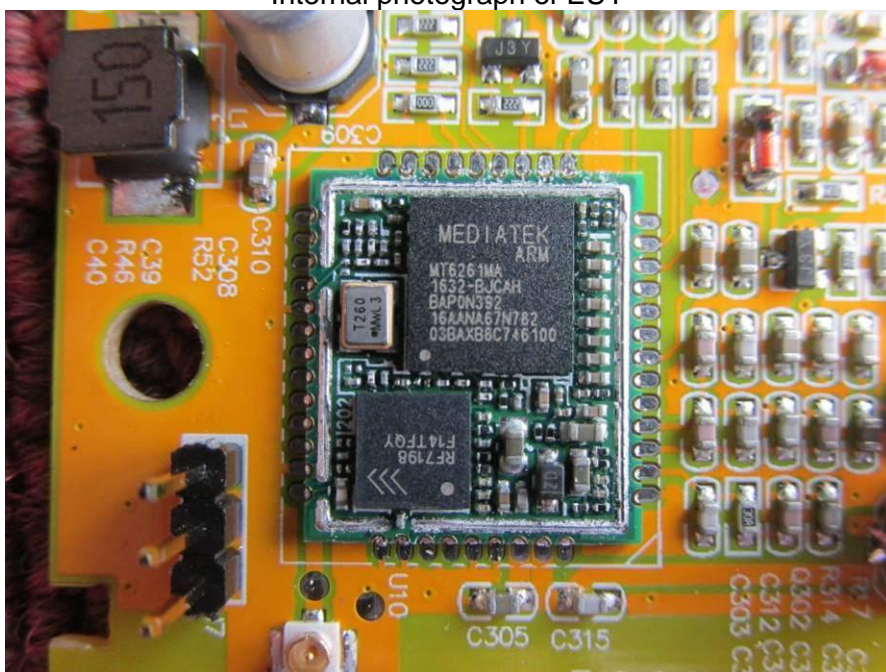

Internal photograph of EUT

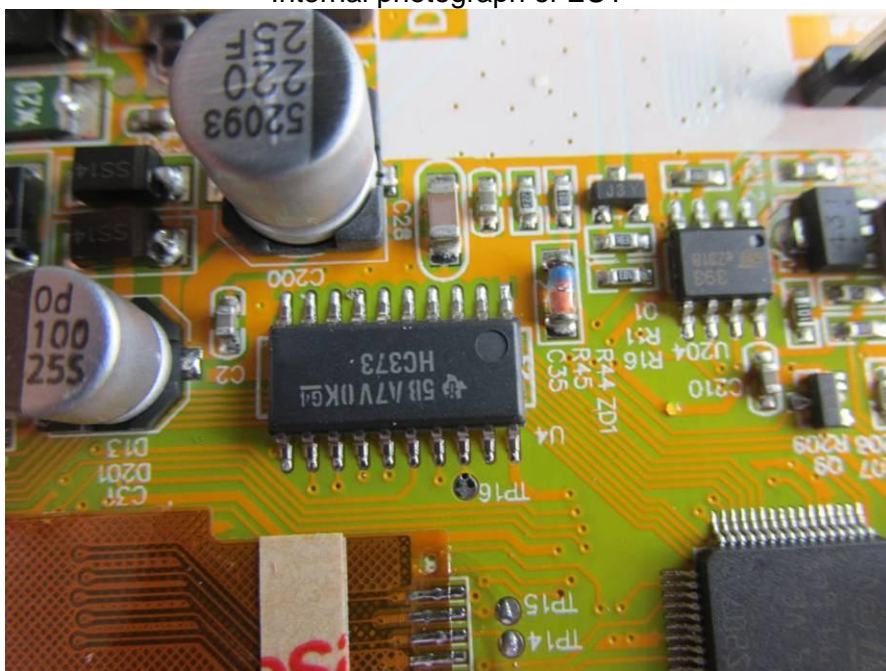



Internal photograph of EUT

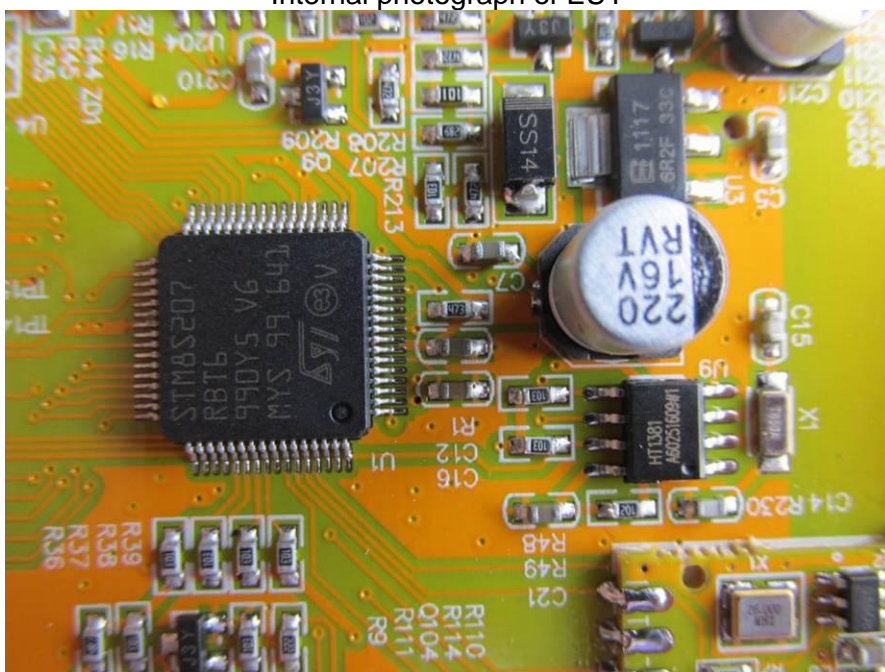

Internal photograph of EUT

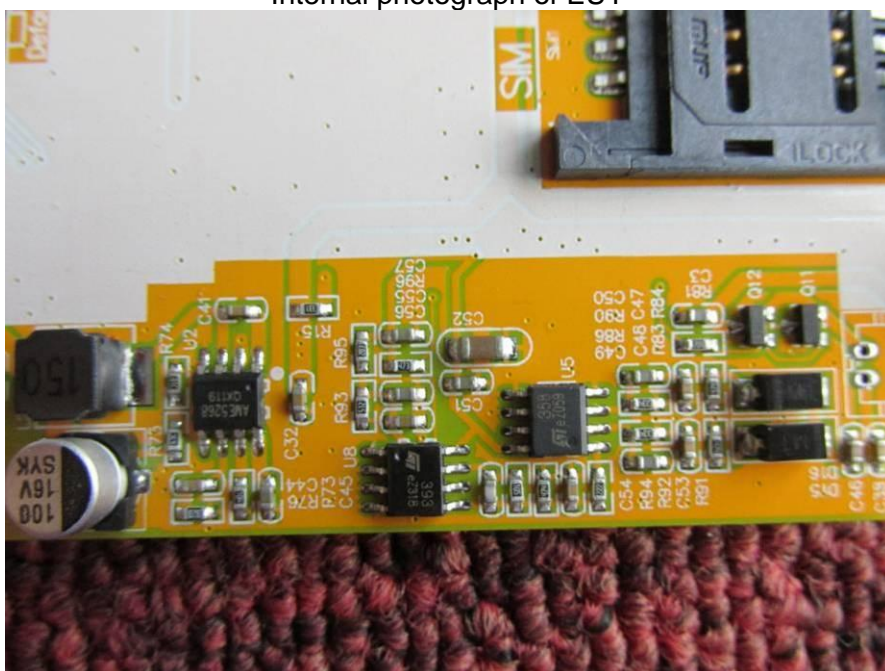

---END OF REPORT---