

# FCC RADIO TEST REPORT

## FCC 47 CFR PART 15 SUBPART C

<b>Test Standard</b>	<b>FCC Part 15.231</b>
<b>FCC ID</b>	<b>2ALECLINK100</b>
<b>Trade name</b>	<b>Buddy</b>
<b>Product name</b>	<b>Ohm Link 100</b>
<b>Model No.</b>	<b>Ohm Link 100</b>
<b>Operation Freq.</b>	<b>434.00MHz</b>
<b>Test Result</b>	<b>Pass</b>

The test Result was tested by Compliance Certification Services Inc. The test data, data evaluation, test procedures, and equipment configurations shown in this report were given in ANSI C63.10: 2013 and compliance standards.

The test results of this report relate only to the tested sample (EUT) identified in this report.

The test Report of full or partial shall not copy. Without written approval of Compliance Certification Services Inc.(Wugu Laboratory)

The sample selected for test was production product and was provided by manufacturer.



Approved by:

A handwritten signature in black ink, appearing to read 'Sam Chuang'.

---

Sam Chuang  
Manager

Reviewed by:

A handwritten signature in black ink, appearing to read 'ED. Chiang'.

---

ED Chiang  
Engineer

## Revision History

Rev.	Issue Date	Revisions	Revised By
00	May 2, 2017	Initial Issue	Angel Cheng
01	May 12, 2017	<ol style="list-style-type: none"> <li>1. Revise Section 1.5 in page 7</li> <li>2. Revise Section 2 in page 9</li> <li>3. Revise Section 4.1.4 in page 13-14</li> <li>4. Revise 99% occupied BW and 20dB Bandwidth in page 15-16</li> <li>5. Revise detector in page 19.</li> </ol>	Angel Cheng
02	May 19 2017	<ol style="list-style-type: none"> <li>1. Revise conducted emission setup photo in page 31.</li> <li>2. Revise section 4.3.4 in page 16,17.</li> <li>3. Add Accessories Equipment in page 8.</li> </ol>	Angel Cheng
03	May 22 2017	<ol style="list-style-type: none"> <li>1. Revise section 4.3.4 in page 18,19</li> </ol>	Angel Cheng

## Table of contents

1. GENERAL INFORMATION .....	4
1.1 EUT INFORMATION .....	4
1.2 EUT CHANNEL INFORMATION .....	5
1.3 ANTENNA INFORMATION .....	5
1.4 MEASUREMENT UNCERTAINTY.....	6
1.5 FACILITIES AND TEST LOCATION .....	7
1.6 INSTRUMENT CALIBRATION .....	7
1.7 SUPPORT AND EUT ACCESSORIES EQUIPMENT .....	8
2. TEST SUMMERY .....	9
3. DESCRIPTION OF TEST MODES .....	10
3.1 THE WORST MODE OF OPERATING CONDITION .....	10
3.2 THE WORST MODE OF MEASUREMENT .....	10
3.3 EUT DUTY CYCLE.....	11
4. TEST RESULT .....	12
4.1 AC POWER LINE CONDUCTED EMISSION .....	12
4.2 EMISSION BANDWIDTH .....	15
4.3 FIELD STRENGTH OF FUNDAMENTAL .....	17
4.4 RADIATION UNWANTED EMISSION .....	20
4.5 OPERATION RESTRICTION.....	28

### APPENDIX 1 – PHOTOGRAPHS OF EUT

# 1. GENERAL INFORMATION

## 1.1 EUT INFORMATION

Applicant	Buddy Platform, Inc. 217 Pine Street, Suite 700 Seattle, WA 98101, USA
Equipment	Ohm Link 100
Model Name	Ohm Link 100
Model Discrepancy	N/A
Received Date	February 24, 2017
Date of Test	April 24 ~ May 15, 2017
Maximum Output Power	1mW
Periodic operation	<input type="checkbox"/> (1) A manually operated transmitter shall employ a switch that will automatically deactivate the transmitter within not more than 5 seconds of being released. <input type="checkbox"/> (2) A transmitter activated automatically shall cease transmission within 5 seconds after activation <input type="checkbox"/> (3) Periodic transmissions at regular predetermined intervals are not permitted. <input checked="" type="checkbox"/> (4) Periodic transmissions (lower field strength): each transmission is not greater than 1 sec and the silent period between transmissions is at least 30 times the duration of the transmission but in no case less than 10 sec.
Power Operation	<input checked="" type="checkbox"/> AC Adapter 1. HON-KWANG Model: A9-02A I/P: 120VAC, 60Hz, 5W O/P:9VAC, 200mA 2. I.T.E. POWER SUPPLY Model: HK-U-050A120-CP I/P: 100-240V, 50/60Hz, 0.2A O/P:5V, 1.2A <input checked="" type="checkbox"/> DC Type : <input checked="" type="checkbox"/> Battery : 4.5V <input type="checkbox"/> DC Power Supply <input type="checkbox"/> External DC adapter

## 1.2 EUT CHANNEL INFORMATION

Frequency Range	434.00 MHz
Modulation Type	GFSK
Bandwidth	118.96 KHz
Number of Channels	1 channel

**Remark:**

Refer as ANSI 63.10:2013 clause 5.6.1 Table 4 for test channels

Number of frequencies to be tested		
Frequency range in which device operates	Number of frequencies	Location in frequency range of operation
<input checked="" type="checkbox"/> 1 MHz or less	1	Middle
<input type="checkbox"/> 1 MHz to 10 MHz	2	1 near top and 1 near bottom
<input type="checkbox"/> More than 10 MHz	3	1 near top, 1 near middle, and 1 near bottom

## 1.3 ANTENNA INFORMATION

<b>Antenna Type</b>	Omni Antenna
<b>Antenna Gain</b>	2 dBi

## 1.4 MEASUREMENT UNCERTAINTY

PARAMETER	UNCERTAINTY
AC Powerline Conducted Emission	+/- 1.2575
Emission bandwidth, 20dB bandwidth	+/- 1.4003
RF output power, conducted	+/- 1.1372
Power density, conducted	+/- 1.4003
3M Semi Anechoic Chamber / 30M~200M	+/- 4.0138
3M Semi Anechoic Chamber / 200M~1000M	+/- 3.9483
3M Semi Anechoic Chamber / 1GHz~8GHz	+/- 2.5975
3M Semi Anechoic Chamber / 8GHz~18GHz	+/- 2.6112
3M Semi Anechoic Chamber / 18GHz~26GHz	+/- 2.7389
3M Semi Anechoic Chamber / 26GHz~40GHz	+/- 2.9683
3M Semi Anechoic Chamber / 40GHz~60GHz	+/- 1.8509
3M Semi Anechoic Chamber / 60GHz~75GHz	+/- 1.9869
3M Semi Anechoic Chamber / 75GHz~110GHz	+/- 2.9651
3M Semi Anechoic Chamber / 110GHz~170GHz	+/- 2.7807
3M Semi Anechoic Chamber / 170GHz~220GHz	+/- 3.6437
3M Semi Anechoic Chamber / 220GHz~325GHz	+/- 4.2982

**Remark:**

1. This uncertainty represents an expanded uncertainty expressed at approximately the 95% confidence level using a coverage factor of  $k=2$
2. ISO/IEC 17025 requires that an estimate of the measurement uncertainties associated with the emissions test results be included in the report.

## 1.5 FACILITIES AND TEST LOCATION

All measurement facilities used to collect the measurement data are located at No.11, Wugong 6th Rd., Wugu Dist., New Taipei City 24891, Taiwan. (R.O.C.)

Test site	Test Engineer	Remark
AC Conduction Room	Eric Lee	-
Radiation	ED Chiang	-
RF Conducted	Eric Lee	-

**Remark:** The sites are constructed in conformance with the requirements of ANSI C63.7, ANSI C63.4 and CISPR Publication 22.

## 1.6 INSTRUMENT CALIBRATION

RF Conducted Test Site					
Equipment	Manufacturer	Model	S/N	Cal Date	Cal Due
Spectrum Analyzer	R&S	FSV 40	101073	10/05/2016	10/04/2017

3M 966 Chamber Test Site					
Equipment	Manufacturer	Model	S/N	Cal Date	Cal Due
Bilog Antenna	Sunol Sciences	JB3	A030105	07/03/2016	07/02/2017
Horn Antenna	EMCO	3117	00055165	02/20/2017	02/19/2018
Pre-Amplifier	EMCI	EMC 012635	980151	06/23/2016	06/22/2017
Pre-Amplifier	EMEC	EM330	060609	06/08/2016	06/07/2017
Spectrum Analyzer	Agilent	E4446A	US42510252	12/05/2016	12/04/2017
Antenna Tower	CCS	CC-A-1F	N/A	N.C.R	N.C.R
Controller	CCS	CC-C-1F	N/A	N.C.R	N.C.R
Turn Table	CCS	CC-T-1F	N/A	N.C.R	N.C.R
Bilog Antenna	Sunol Sciences	JB3	A030105	07/03/2016	07/02/2017

AC Conducted Emissions Test Site					
Equipment	Manufacturer	Model	S/N	Cal Date	Cal Due
LISN	R&S	ENV216	101054	05/11/2016	05/10/2017
LISN	SCHWARZBECK	NSLK 8127	8127-541	02/14/2017	02/13/2018
Receiver	R&S	ESCI	101073	08/20/2016	08/19/2017

**Remark:** Each piece of equipment is scheduled for calibration once a year.

## 1.7 SUPPORT AND EUT ACCESSORIES EQUIPMENT

There are no accessories and support equipment be used during the test.

EUT Accessories Equipment					
No.	Equipment	Brand	Model	Series No.	FCC ID
1	Current Transformer	YHDC	SCT013-000	N/A	N/A

Support Equipment					
No.	Equipment	Brand	Model	Series No.	FCC ID
	N/A				

## 1.8 Test methodology and applied standards

The test methodology, setups and results comply with all requirements in accordance with ANSI C63.10:2013, FCC 15.231 Rules.

## 1.9 Table of Accreditations and Listings

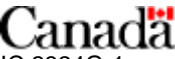
Country	Agency	Scope of Accreditation	Logo
USA	FCC	3M Semi Anechoic Chamber (FCC MRA: TW1039) to perform FCC Part 15 measurements	 FCC MRA: TW1039
Canada	Industry Canada	3M Semi Anechoic Chamber (IC 2324G-1 / IC 2324G-2) to perform	 IC 2324G-1 IC 2324G-2

*\* No part of this report may be used to claim or imply product endorsement by A2LA or any agency of the US Government.*



## 2. TEST SUMMERY

<b>Standard Sec.</b>	<b>Chapter</b>	<b>Test Item</b>	<b>Result</b>
15.203	1.3	Antenna Requirement	Pass
15.207	4.1	AC Power-line Conducted Emission	Pass
15.231(c)	4.2	Emission Bandwidth	Pass
15.231(e)	4.3	Fundamental Emission	Pass
15.231(e)	4.4	Transmitter Radiated Emission	Pass
15.231(a)	4.5	Operation Restriction	Pass

### 3. DESCRIPTION OF TEST MODES

#### 3.1 THE WORST MODE OF OPERATING CONDITION

Operation mode	434.00 MHz
RF Filed strength	Peak : 87.51 dBuv/m Average : 46.58 dBuv/m

Remark: Field strength performed Average level at 3m.

#### 3.2 THE WORST MODE OF MEASUREMENT

AC Power Line Conducted Emission	
Test Condition	AC Power line conducted emission for line and neutral
Voltage/Hz	120V/60Hz
Test Mode	Mode 1:EUT power by AC adapter(A9-02A). Mode 2:EUT power by AC adapter(HK-U-050A120-CP). Mode 3:EUT power by Battery(4.5V).
Worst Mode	<input checked="" type="checkbox"/> Mode 1 <input type="checkbox"/> Mode 2 <input type="checkbox"/> Mode 3 <input type="checkbox"/> Mode 4
Radiated Emission Measurement Above 1G	
Test Condition	Band edge, Emission for Unwanted and Fundamental
Voltage/Hz	120V/60Hz
Test Mode	Mode 1:EUT power by AC adapter(A9-02A). Mode 2:EUT power by AC adapter(HK-U-050A120-CP). Mode 3:EUT power by Battery(4.5V).
Worst Mode	<input checked="" type="checkbox"/> Mode 1 <input type="checkbox"/> Mode 2 <input type="checkbox"/> Mode 3 <input type="checkbox"/> Mode 4
Worst Position	<input type="checkbox"/> Placed in fixed position. <input checked="" type="checkbox"/> Placed in fixed position at X-Plane (E2-Plane) <input type="checkbox"/> Placed in fixed position at Y-Plane (E1-Plane) <input type="checkbox"/> Placed in fixed position at Z-Plane (H-Plane)
Worst Polarity	<input checked="" type="checkbox"/> Horizontal <input type="checkbox"/> Vertical
Radiated Emission Measurement Below 1G	
Test Condition	Radiated Emission Below 1G
Voltage/Hz	120V/60Hz
Test Mode	Mode 1:EUT power by AC adapter(A9-02A). Mode 2:EUT power by AC adapter(HK-U-050A120-CP). Mode 3:EUT power by Battery(4.5V).
Worst Mode	<input checked="" type="checkbox"/> Mode 1 <input type="checkbox"/> Mode 2 <input type="checkbox"/> Mode 3 <input type="checkbox"/> Mode 4

**Remark:**

1. The worst mode was record in this test report.
2. EUT pre-scanned in three axis ,X,Y, Z and two polarity, Horizontal and Vertical for radiated measurement. The worst case(X-Plane and Horizontal) were recorded in this report
3. AC power line conducted emission and for below 1G radiation emission were performed the EUT transmit at the highest output power channel as worse case.

### 3.3 EUT DUTY CYCLE

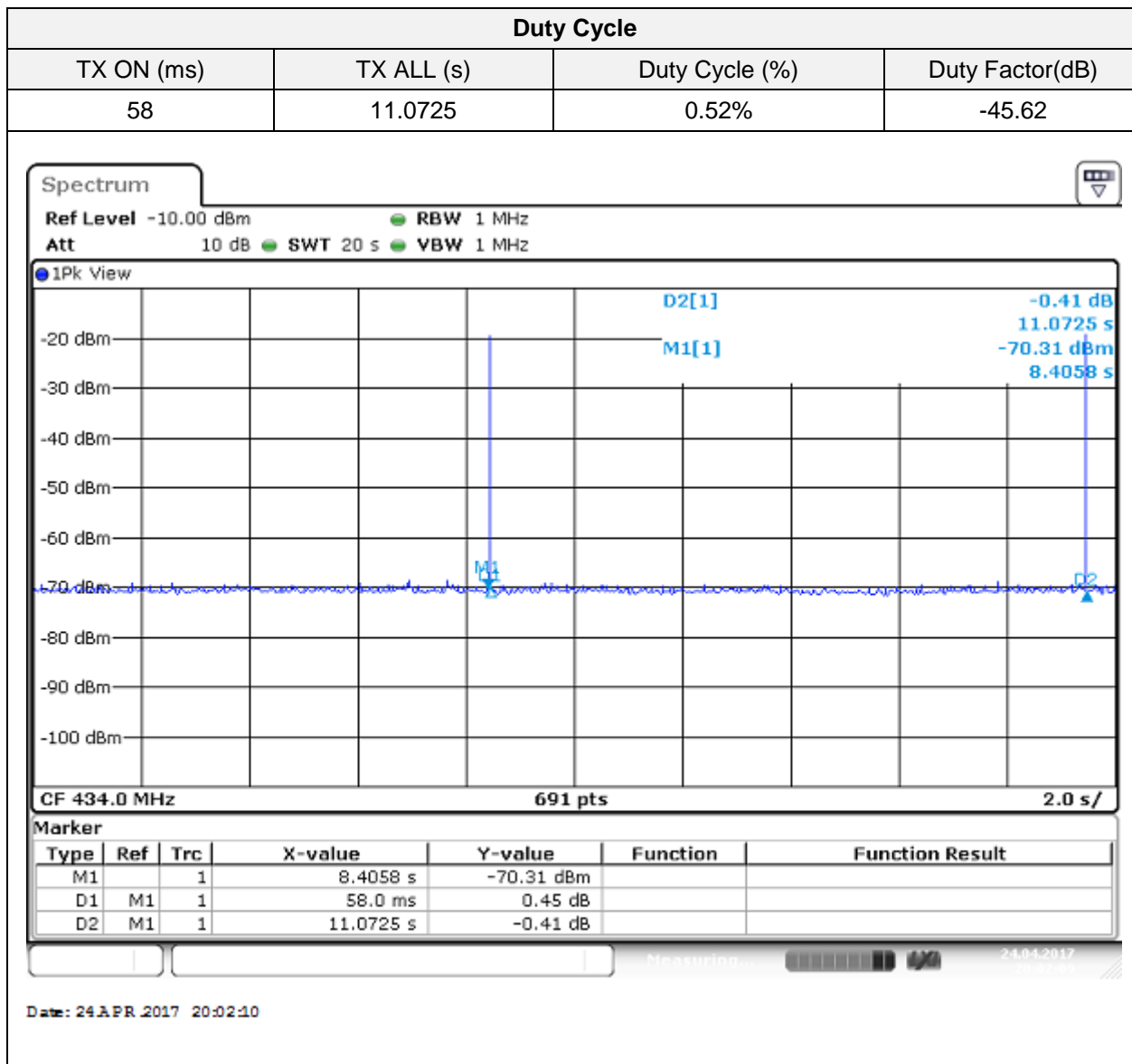

## 4. TEST RESULT

### 4.1 AC POWER LINE CONDUCTED EMISSION

#### 4.1.1 Test Limit

According to §15.207(a) ,

Frequency Range (MHz)	Limits(dBμV)	
	Quasi-peak	Average
0.15 to 0.50	66 to 56*	56 to 46*
0.50 to 5	56	46
5 to 30	60	50

\* Decreases with the logarithm of the frequency.

#### 4.1.2 Test Procedure

Test method Refer as ANSI 63.10:2013 clause 6.2,

1. The EUT was placed on a table, which is 0.8m above ground plane.
2. Maximum procedure was performed on the six highest emissions to ensure EUT compliance.
3. Repeat above procedures until all frequency measured were complete

#### 4.1.3 Test Setup

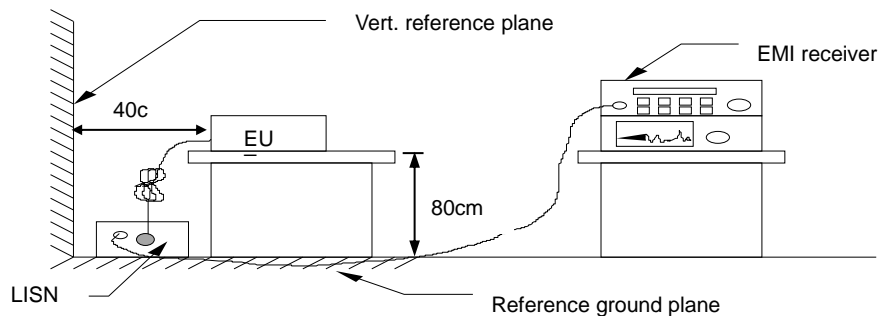

### 4.1.4 Test Result

#### Test Data

Test Mode:	Mode 1	Test Date	2017/04/28
Temp/Hum	24(°C)/ 50%RH	Test Engineer	Eric Lee
Phase:	Line		

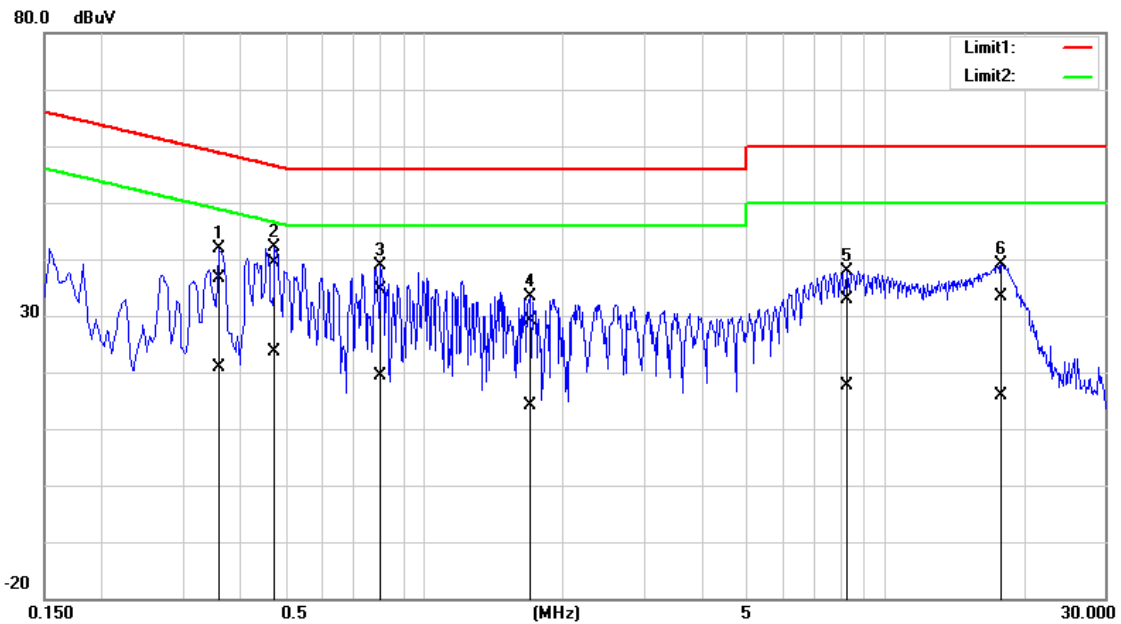

Frequency (MHz)	Quasi Peak reading (dBuV)	Average reading (dBuV)	Correction factor (dB)	Quasi Peak result (dBuV)	Average result (dBuV)	Quasi Peak limit (dBuV)	Average limit (dBuV)	Quasi Peak margin (dB)	Average margin (dB)	Remark
0.3580	26.97	11.27	9.68	36.65	20.95	58.77	48.77	-22.12	-27.82	Pass
0.4740	29.65	13.96	9.68	39.33	23.64	56.44	46.44	-17.11	-22.80	Pass
0.8060	24.91	9.68	9.69	34.60	19.37	56.00	46.00	-21.40	-26.63	Pass
1.7020	19.36	4.40	9.70	29.06	14.10	56.00	46.00	-26.94	-31.90	Pass
8.3180	23.11	8.00	9.75	32.86	17.75	60.00	50.00	-27.14	-32.25	Pass
17.8500	23.58	5.97	9.84	33.42	15.81	60.00	50.00	-26.58	-34.19	Pass

Test Mode:	Mode 1	Test Date	2017/04/28
Temp/Hum	27(°C)/ 53%RH	Test Engineer	Eric Lee
Phase:	Neutral		

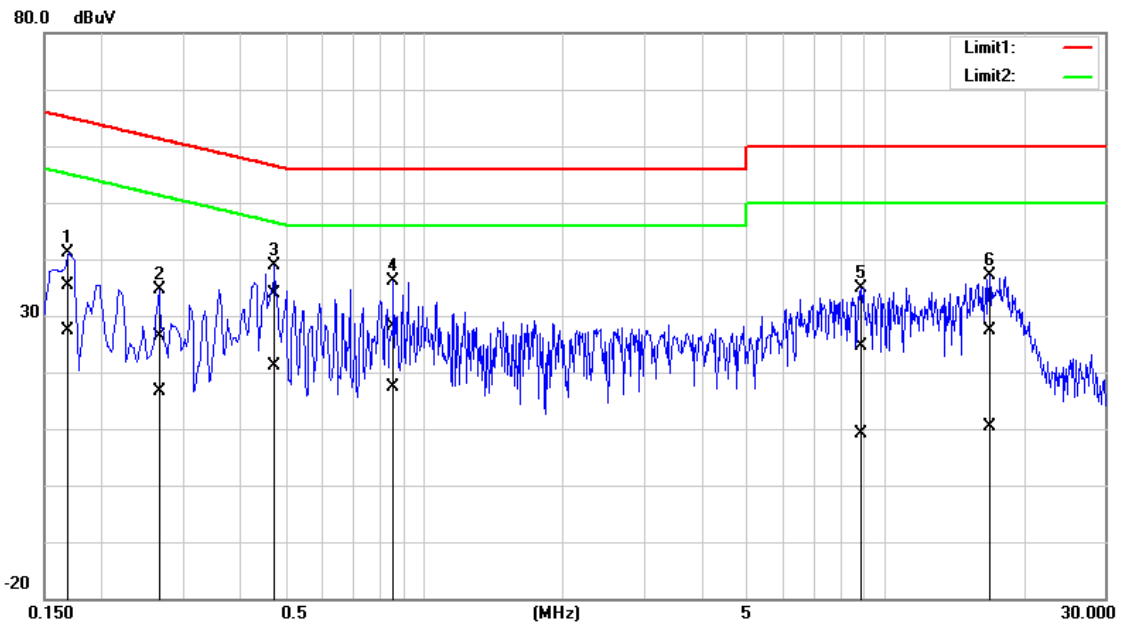

Frequency (MHz)	Quasi Peak reading (dBuV)	Average reading (dBuV)	Correction factor (dB)	Quasi Peak result (dBuV)	Average result (dBuV)	Quasi Peak limit (dBuV)	Average limit (dBuV)	Quasi Peak margin (dB)	Average margin (dB)	Remark
0.1700	25.74	17.63	9.71	35.45	27.34	64.96	54.96	-29.51	-27.62	Pass
0.2660	16.62	6.93	9.70	26.32	16.63	61.24	51.24	-34.92	-34.61	Pass
0.4740	24.19	11.50	9.69	33.88	21.19	56.44	46.44	-22.56	-25.25	Pass
0.8580	18.32	7.74	9.69	28.01	17.43	56.00	46.00	-27.99	-28.57	Pass
8.9140	14.82	-0.67	9.76	24.58	9.09	60.00	50.00	-35.42	-40.91	Pass
16.8740	17.50	0.57	9.88	27.38	10.45	60.00	50.00	-32.62	-39.55	Pass

## 4.2 EMISSION BANDWIDTH

### 4.2.1 Test Limit

According to §15.231(c) ,

Limit	<input checked="" type="checkbox"/> 70 MHz - 900 MHz : $F_c * 0.25 \%$ <input type="checkbox"/> Above 900 MHz : $F_c * 0.5 \%$
-------	---

### 4.2.2 Test Procedure

Test method Refer as ANSI 63.10:2013 clause 6.9.2,

The Loop antenna connected to the spectrum analyzer, was touching to the transmitter antenna. Set the RBW=10KHz, VBW ≥ 3 x RBW, Detector = Peak, Trace mode = Max hold, Sweep = Auto. Measure the maximum width of the emission that is constrained by the frequencies associated with the 20dB Bandwidth and Occupied Bandwidth(99%).

### 4.2.3 Test Setup

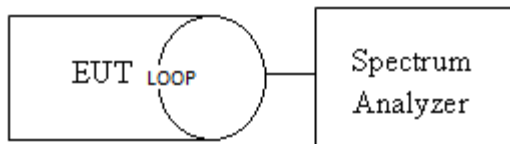

### 4.2.4 Test Result

Spectrum Bandwidth			
Frequency (MHz)	99% Occupied BW (KHz)	20dB Bandwidth (KHz)	20dB Bandwidth Limits (MHz)
434.00	100.724	94.650	1.08

**Test Data**

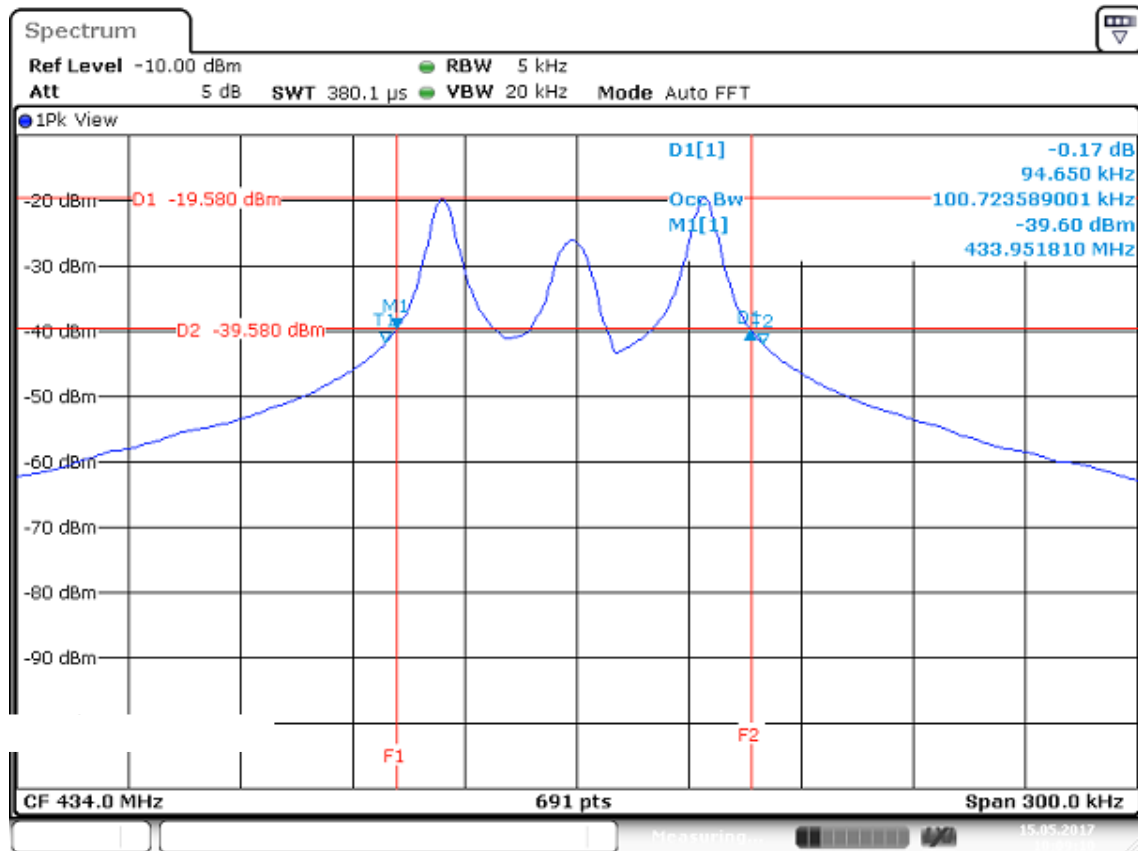

Date: 15 MAY 2017 10:09:10



### 4.3 FIELD STRENGTH OF FUNDAMENTAL

#### 4.3.1 Test Limit

According to §15.231(e), For Periodic transmissions (lower field strength): each transmission is not greater than 1 sec and the silent period between transmissions is at least 30 times the duration of the transmission but in no case less than 10 sec.

Fundamental frequency (MHz)	Field strength of fundamental (microvolts/meter)	Field strength of spurious emission (microvolts/meter)
40.66-40.70	1,000	100
70-130	500	50
130-174	500 to 1,500 <sup>1</sup>	50 to 150 <sup>1</sup>
174-260	1,500	150
260-470	1,500 to 5,000 <sup>1</sup>	150 to 500 <sup>1</sup>
Above 470	5,000	500

**REMARK:**

1. Linear interpolations
2. Based on the average value of the measured Field strength of fundamental.

#### 4.3.2 Test Procedure

Test method Refer as ANSI 63.10:2013 clause 4.1.4 and clause 6.5

clause 4.1.4	<input checked="" type="checkbox"/> 4.1.4.2.2: Measurement Peak value. <input type="checkbox"/> 4.1.4.2.3: Duty cycle ≥ 100%. <input checked="" type="checkbox"/> 4.1.4.2.4: Measurement Average value.
--------------	---

**REMARK:**

1. Duty factor =  $20 \log(\text{dwell time})$
2. Average emission = Peak emission +  $20 \log(\text{duty cycle})$ .

### 4.3.3 Test Setup

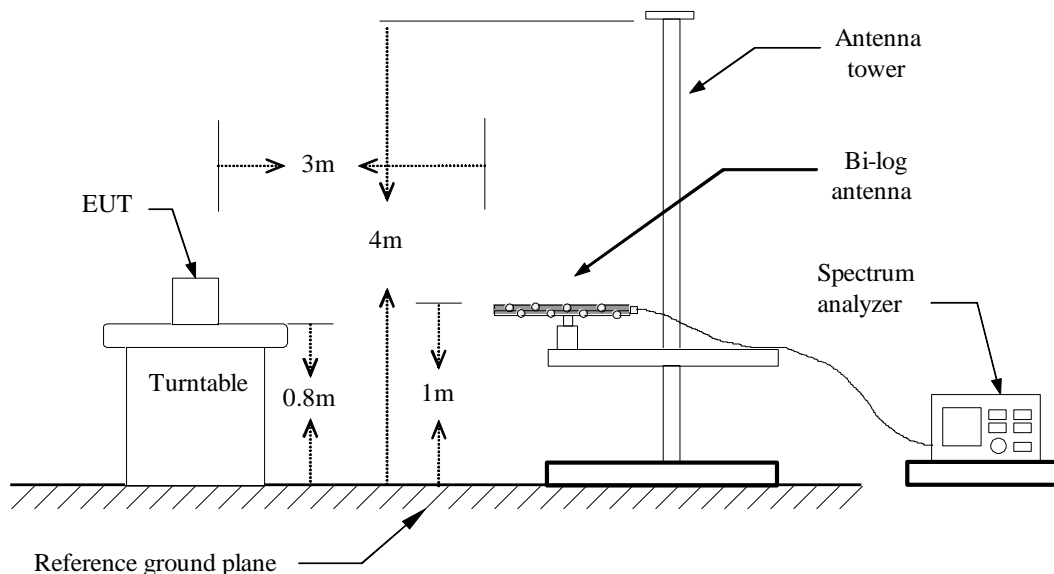

### 4.3.4 Test Result

Field Strength					
Frequency (MHz)	Fundamental (dBuV/m) at 3m	Limit (dBuV/m) at 3m	Margin (dB)	Axis/Pol.	Remark
434.00	41.89	72.87	-30.98	X/H	Avg

**Remark**

1. Average results = actual peak readings + correction factor (-45.62 dB).
2. The correction factor can be referring duty factor of section 3.3
3. Fundamental measured method setting on spectrum, RBW=100 kHz, VBW=100kHz and Detector=Peak.

**Test Data**

Test Mode:	TX	Temp/Hum	27(°C)/ 53%RH
Test Item	Fundamental	Test Date	2017/04/26
Axis/Polarize	X-Plane/Hor	Test Engineer	ED Chiang.
Detector	Peak		

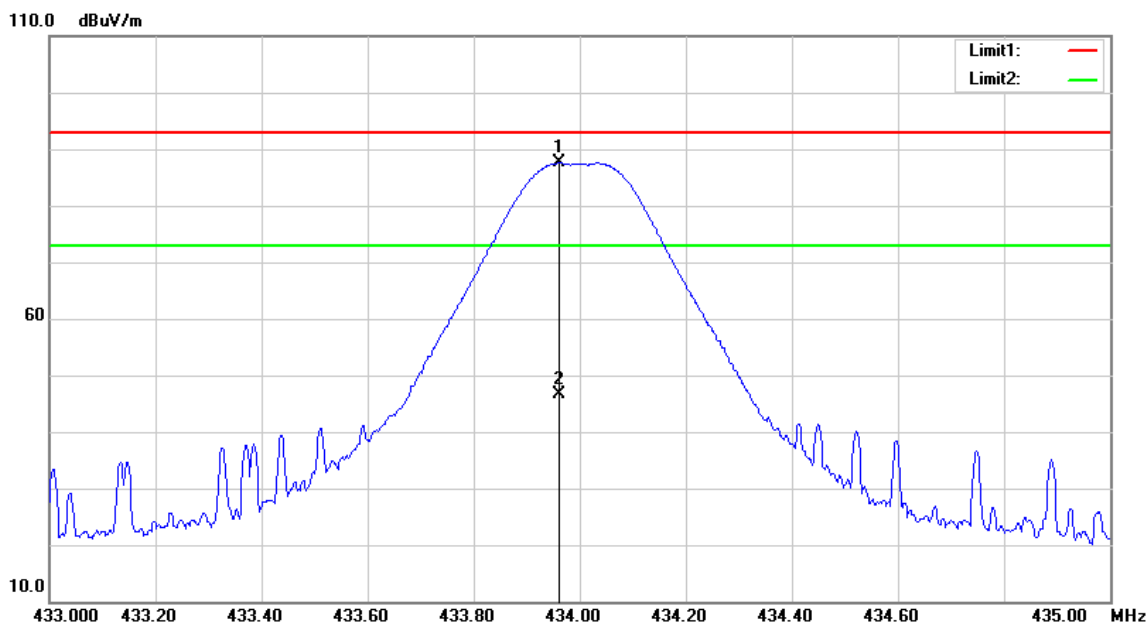

No.	Frequency (MHz)	Reading (dBuV)	Correct Factor(dB/m)	Result (dBuV/m)	Limit (dBuV/m)	Margin (dB)	Remark
1	433.9620	100.61	-13.10	87.51	92.87	-5.36	peak
2	433.9620	59.68	-13.10	41.89	72.87	-30.98	AVG

Average results = actual peak readings + correction factor (-45.62 dB)

## 4.4 RADIATION UNWANTED EMISSION

### 4.4.1 Test Limit

According to §15.231(e) and §15.209

Unwanted emissions limit follow the table or the FCC Part 15.209.

According to §15.231(e), For Periodic transmissions (lower field strength): each transmission is not greater than 1 sec and the silent period between transmissions is at least 30 times the duration of the transmission but in no case less than 10 sec.

Fundamental frequency (MHz)	Field strength of fundamental (microvolts/meter)	Field strength of spurious emission (microvolts/meter)
40.66-40.70	1,000	100
70-130	500	50
130-174	500 to 1,500 <sup>1</sup>	50 to 150 <sup>1</sup>
174-260	1,500	150
260-470	1,500 to 5,000 <sup>1</sup>	150 to 500 <sup>1</sup>
Above 470	5,000	500

**REMARK:**

1. Linear interpolations
2. Based on the average value of the measured Field strength of fundamental.

### Below 30MHz

Frequency (MHz)	Field Strength				
	(µV/m)	(dBµV/m)	Measurement Distance (meter)	(dBµV/m)	Measurement Distance (meter)
0.009 - 0.490	2400/F(kHz)	48.52 – 13.80	300	128.52– 104.84	3
0.490 - 1.705	24000/F(kHz)	33.80 – 22.97	30	73.80– 62.97	3
1.705 – 30.0	30	29.54	30	69.54	3

### Above 30MHz

Frequency (MHz)	Field Strength		Measurement Distance (meter)
	(µV/m)	(dBµV/m)	
30-88	100	40.0	3
88-216	150	43.5	3
216-960	200	46.0	3
Above 960	500	54.0	3

### 4.4.2 Test Procedure

Test method Refer as ANSI 63.10:2013

<input checked="" type="checkbox"/> Unwanted Emission	<input checked="" type="checkbox"/> clause 4.1.4.2.2: Measurement Peak value. <input type="checkbox"/> clause 4.1.4.2.3: Duty cycle $\geq$ 100%. <input checked="" type="checkbox"/> clause 4.1.4.2.4: Measurement Average value.
---	---

**REMARK:**

1. Duty factor =  $20\log(\text{dwell time}/100\text{ ms})$
2. Average emission = Peak emission +  $20\log(\text{duty cycle})$ .

<input checked="" type="checkbox"/> Radiated Emission	<input checked="" type="checkbox"/> clause 6.4: below 30 MHz and test distance is 3m. <input checked="" type="checkbox"/> clause 6.5: below 30 MHz -1 GHz and test distance is 3m. <input checked="" type="checkbox"/> clause 6.6: Above 30 MHz and test distance is 3m.
---	--

1. The EUT is placed on a turntable, which is 0.8m for test below 1GHz and 1.5m for test above 1GHz, above ground plane.
2. The turntable shall be rotated for 360 degrees to determine the position of maximum emission level.
3. EUT is set 3m away from the receiving antenna, which is varied from 1m to 4m to find out the highest emissions.
4. Maximum procedure was performed on the six highest emissions to ensure EUT compliance.
5. And also, each emission was to be maximized by changing the polarization of receiving antenna both horizontal and vertical.
6. Set the spectrum analyzer in the following setting as:  
 Below 1GHz:  
                     RBW=100kHz / VBW=300kHz / Sweep=AUTO  
 Above 1GHz:  
                     (a)PEAK: RBW=1MHz / VBW=3MHz / Sweep=AUTO  
                     (b)AVERAGE: RBW=1MHz,
7. Repeat above procedures until the measurements for all frequencies are complete.

*Remark.*

1. The EUT has a oscillator operating at 32 MHz, harmonic/spurious was verified. And didn't catch any emission at 32MHz.
2. Although these tests were performed other than open area test site, adequate comparison measurements were confirmed against 30 m open are test site. Therefore sufficient tests were made to demonstrate that the alternative site produces results that correlate with the ones of tests made in an open field based on KDB 937606.
3. No emission found between lowest internal used/generated frequency to 30MHz (9kHz~30MHz).

### 4.4.3 Test Setup

#### 9kHz ~ 30MHz

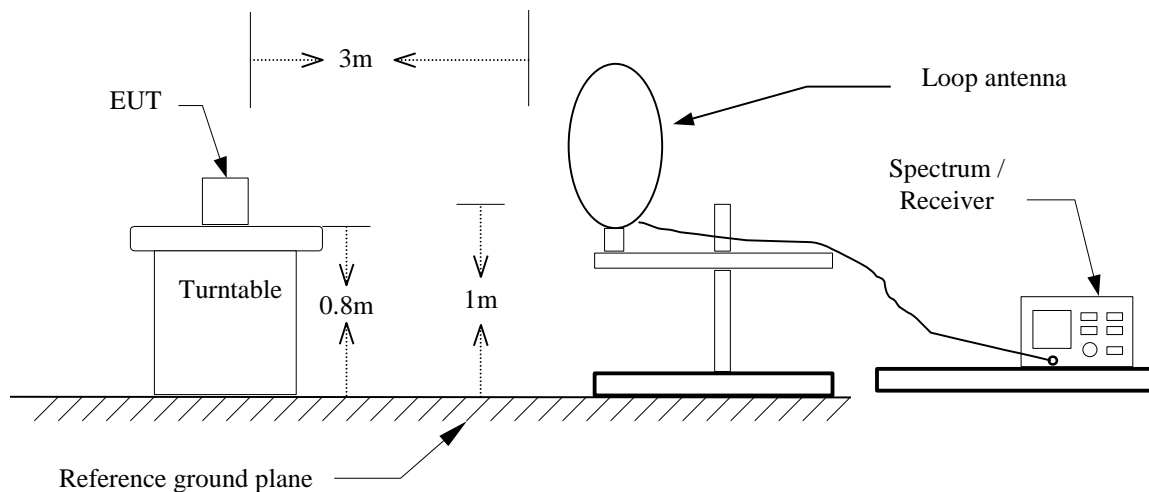

#### 30MHz ~ 1 GHz

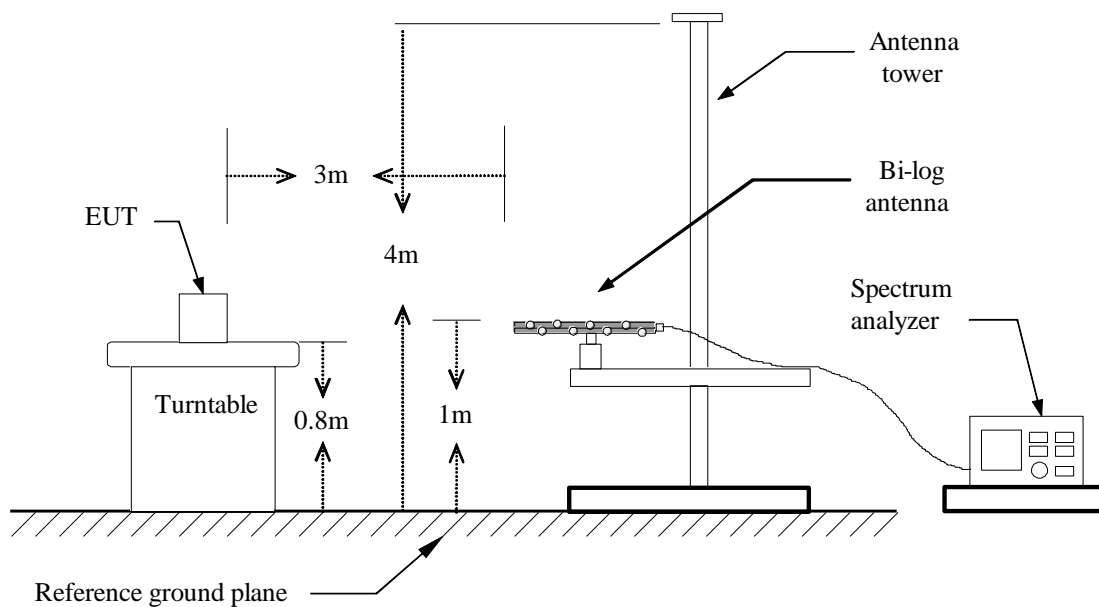

**Above 1 GHz**

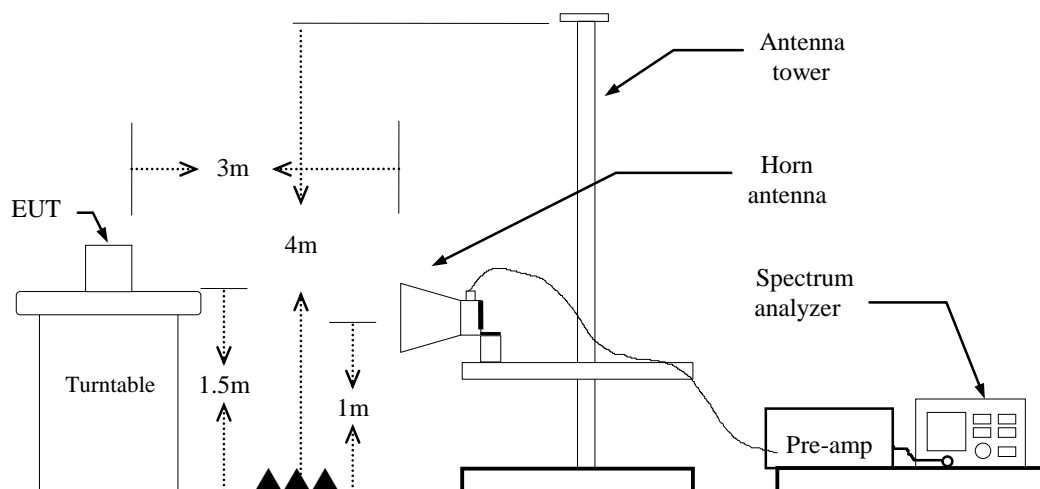

**4.4.4 Test Result**

**Pass.**

**Test Data**

**Below 1GHz**

Test Mode:	TX	Temp/Hum	27(°C)/ 53%RH
Test Item	Below 1GHz	Test Date	2017/04/24
Polarize	Vertical	Test Engineer	ED Chiang.
Detector	Peak		

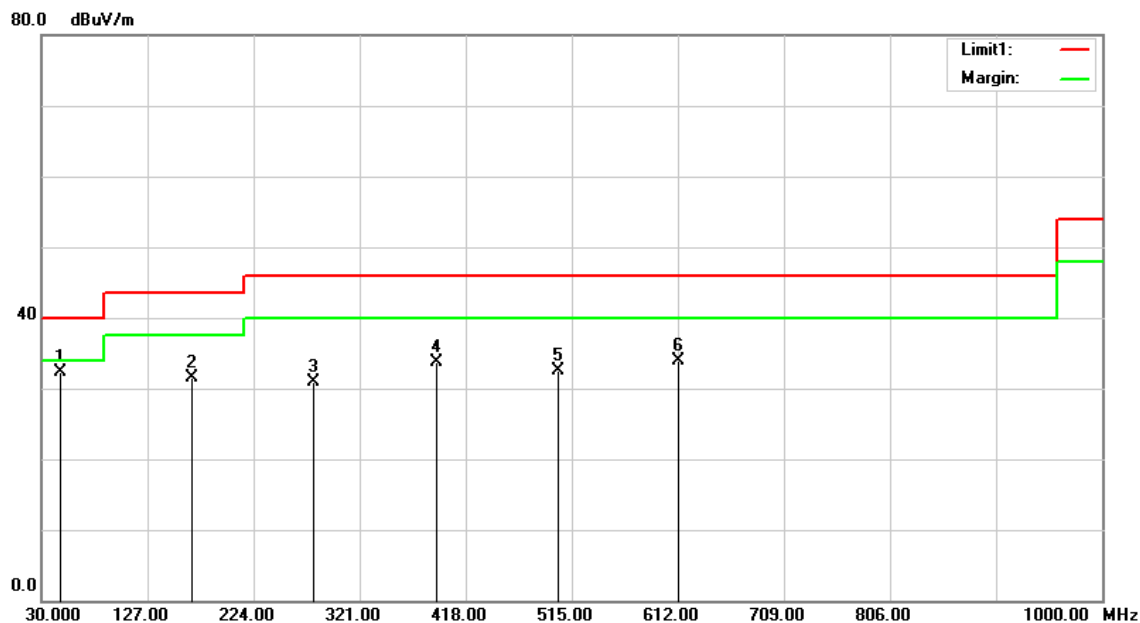

Frequency (MHz)	Reading (dBuV)	Correction Factor (dB/m)	Result (dBuV/m)	Limit (dBuV/m)	Margin (dB)	Remark
47.4600	51.85	-19.61	32.24	40.00	-7.76	QP
167.7400	48.22	-16.74	31.48	43.50	-12.02	peak
279.2900	45.51	-14.63	30.88	46.00	-15.12	peak
390.8400	45.61	-11.92	33.69	46.00	-12.31	peak
502.3900	41.71	-9.20	32.51	46.00	-13.49	peak
612.9700	41.35	-7.45	33.90	46.00	-12.10	peak



Test Mode:	TX	Temp/Hum	27(°C)/ 53%RH
Test Item	Below 1GHz	Test Date	2017/04/24
Polarize	Horizontal	Test Engineer	ED Chiang.
Detector	Peak		

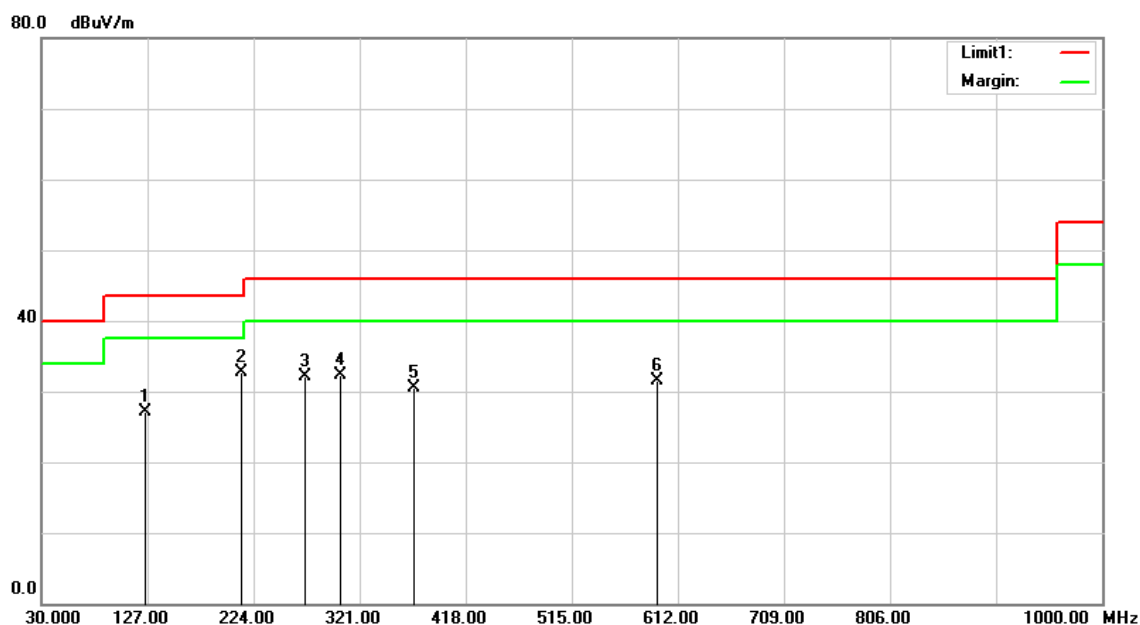

Frequency (MHz)	Reading (dBuV)	Correction Factor (dB/m)	Result (dBuV/m)	Limit (dBuV/m)	Margin (dB)	Remark
125.0600	42.77	-15.5	27.20	43.50	-16.30	peak
212.3600	49.22	-16.42	32.80	43.50	-10.70	peak
271.5300	46.85	-14.77	32.08	46.00	-13.92	peak
303.5400	46.36	-14.14	32.22	46.00	-13.78	peak
370.4700	42.88	-12.40	30.48	46.00	-15.52	peak
593.5700	39.42	-7.85	31.57	46.00	-14.43	peak

**Above 1GHz**

Test Mode:	TX	Temp/Hum	27(°C)/ 53%RH
Test Item	Above 1GHz	Test Date	2017/04/24
Polarize	Vertical	Test Engineer	ED Chiang.
Detector	Peak		

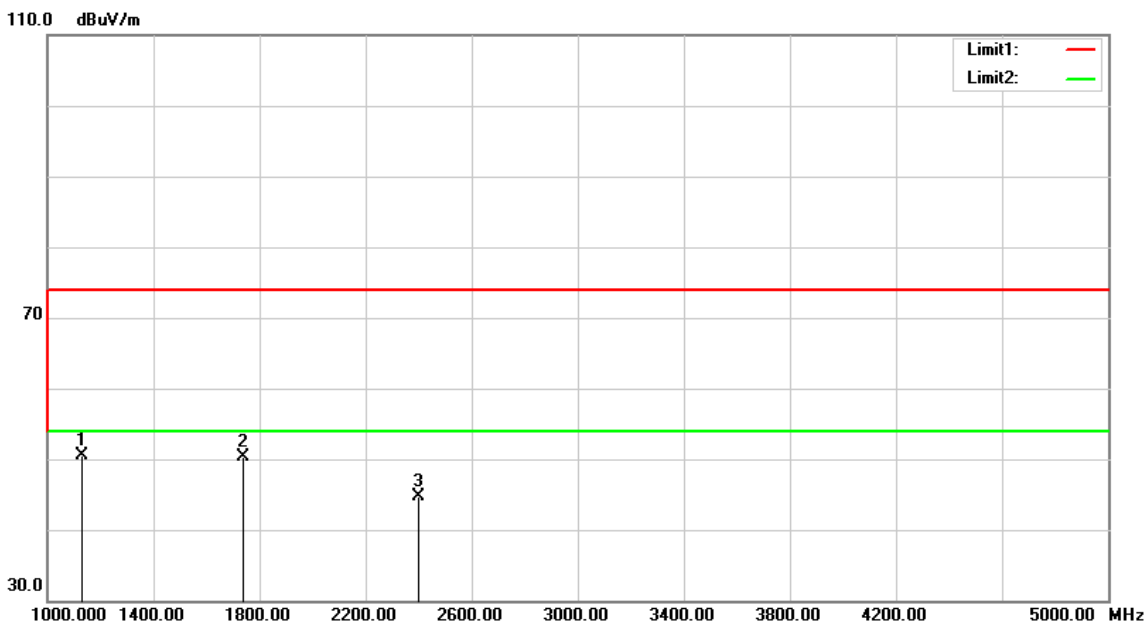

Frequency (MHz)	Reading (dBuV)	Correction Factor (dB/m)	Result (dBuV/m)	Limit (dBuV/m)	Margin (dB)	Remark
1132.000	58.03	-7.48	50.55	74.00	-23.45	peak
1736.000	55.32	-4.97	50.35	74.00	-23.65	peak
2400.000	47.14	-2.41	44.73	74.00	-29.27	peak

**Remark:**

1. Measuring frequencies from 1 GHz to the 10th harmonic of highest fundamental frequency.

Test Mode:	TX	Temp/Hum	27(°C)/ 53%RH
Test Item	Above 1GHz	Test Date	2017/04/24
Polarize	Horizontal	Test Engineer	ED Chiang.
Detector	Peak		

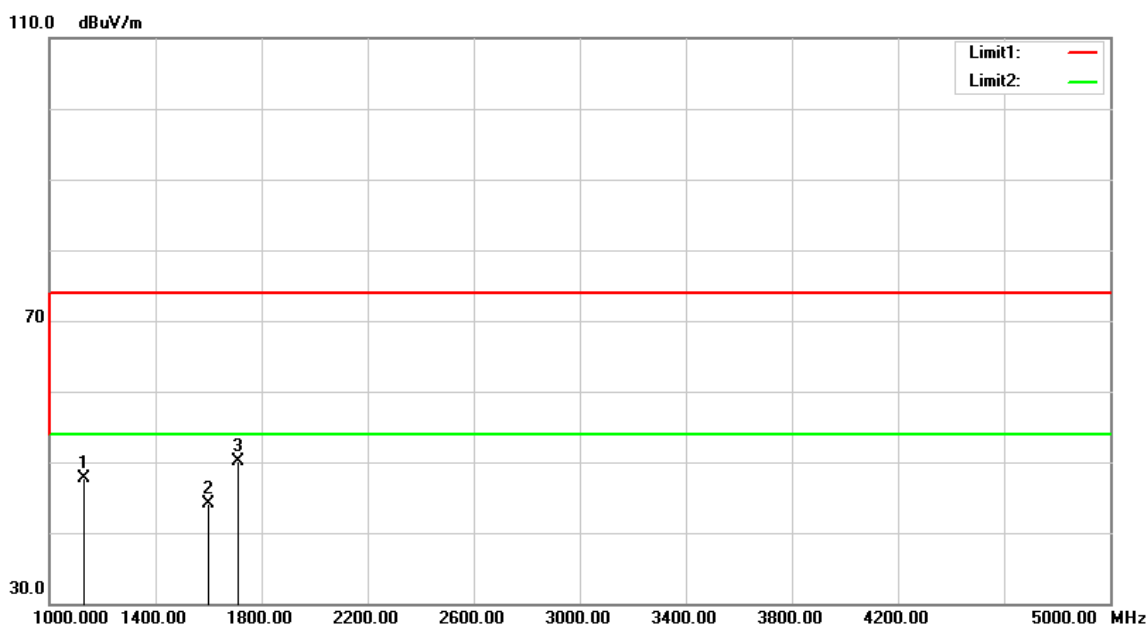

Frequency (MHz)	Reading (dBuV)	Correction Factor (dB/m)	Result (dBuV/m)	Limit (dBuV/m)	Margin (dB)	Remark
1132.000	55.27	-7.48	47.79	74.00	-26.21	peak
1600.000	49.69	-5.67	44.02	74.00	-29.98	peak
1712.000	55.24	-5.09	50.15	74.00	-23.85	peak

**Remark:**

1. Measuring frequencies from 1 GHz to the 10th harmonic of highest fundamental frequency.

## 4.5 OPERATION RESTRICTION

### 4.5.1 Test Limit

According to §15.231(a) (e).

Devices operated under the provisions of this paragraph shall be provided with a means for automatically limiting operation so that the duration of each transmission shall not be greater than one second and the silent period between transmissions shall be at least 30 times the duration of the transmission but in no case less than 10 seconds.

### 4.5.2 Test Procedure

Test method Refer as ANSI 63.10:2013 clause 7.4

The Loop antenna connected to the spectrum analyzer, was touching to the transmitter antenna. Set the RBW=1MHz, VBW ≥ 3 x RBW, Detector = Peak, Trace mode = Max hold, Sweep = 20s.Measure

### 4.5.3 Test Setup

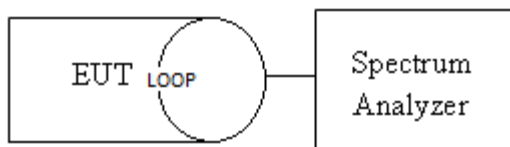

### 4.5.4 Test Result

Dwell Time		
Operation condition	Burst Duration	Limits
Automatically Operated	58 ms	1 sec

**Test Data**

