

Smart Cat Litter Toilet



Precautions for use

Before use, please carefully read this product manual. Once installed or used, it means that you have carefully read and accepted the following safety instructions. Our company is not responsible or liable for any accidents or losses caused by illegal operations. The interpretation and modification rights of this statement belong to our company.

WARNING

- Do not use damp hands to plug or unplug the power adapter.
- Any abnormality with this product, please immediately stop using it and unplug the power adapter.。
- Please use indoors and stay away from ignition sources.
- Pets biting wires may cause electrical leakage. Please guide the use correctly.
- When using, please stay away from other electrical equipment to prevent damage caused by accidental water splashing.
- Do not disassemble or repair this product without permission, as it may cause injury or machine malfunction.

Attention

Please do not place this product at a high place to prevent it from falling and causing product damage or pet safety issues. At the same time, to prevent pets from falling over the product, it is recommended to place it in a corner or against a wall.

Keep the device level and do not overturn it, as it may cause it to malfunction. If children are using this device, please ensure to use it under adult guidance.

Except for maintenance personnel, no one is allowed to repair this product to avoid causing various unexpected injuries. The maximum height of cat litter added shall not exceed the (MAX) marking line.

This product recommends using tofu cat litter or mixed cat litter.

This product cannot be washed with water, only the surface can be wiped and dried before use.

Be sure to place the machine on a flat and hard ground (do not place it on flexible materials such as carpets or surfaces with height differences), otherwise it will affect the normal operation of the machine.

Do not use this product for a long time in an environment with strong magnetic fields, as this may cause the device to malfunction.

This device complies with Part 15 of the FCC Rules. Operation is subject to the following two conditions:

- (1) this device may not cause harmful interference, and
- (2) this device must accept any interference received, including interference that may cause undesired operation.

Attention

FCC WARNING

This device complies with part 15 of the FCC Rules. Operation is subject to the following two conditions: (1) this device may not cause harmful interference, and (2) this device must accept any interference received, including interference that may cause undesired operation.

Any changes or modifications not expressly approved by the party responsible for compliance could void the user's authority to operate the equipment.

NOTE: This equipment has been tested and found to comply with the limits for a Class B digital device, pursuant to Part 15 of the FCC Rules. These limits are designed to provide reasonable protection against harmful interference in a residential installation. This equipment generates, uses and can radiate radio frequency energy and, if not installed and used in accordance with the instructions, may cause harmful interference to radio communications.

However, there is no guarantee that interference will not occur in a particular installation. If this equipment does cause harmful interference to radio or television reception,

which can be determined by turning the equipment off and on, the user is encouraged to try to correct the interference by one or more of the following measures:

- Reorient or relocate the receiving antenna.
- Increase the separation between the equipment and receiver.
- Connect the equipment into an outlet on a circuit different from that to which the receiver is connected.
- Consult the dealer or an experienced radio/TV technician for help.

To maintain compliance with FCC's RF Exposure guidelines, This equipment should be installed and operated with minimum 20cm distance between the radiator and your body: Use only the supplied antenna.

Component Instruction

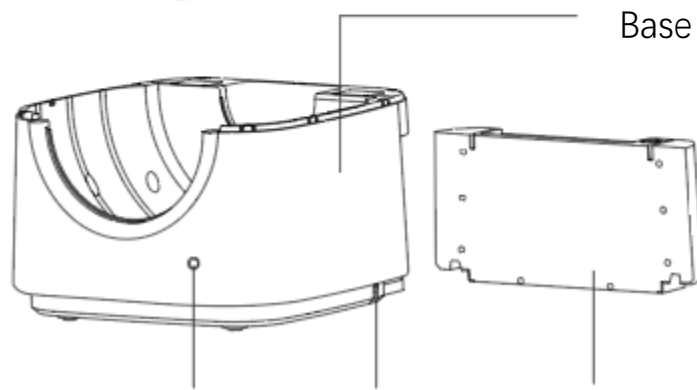
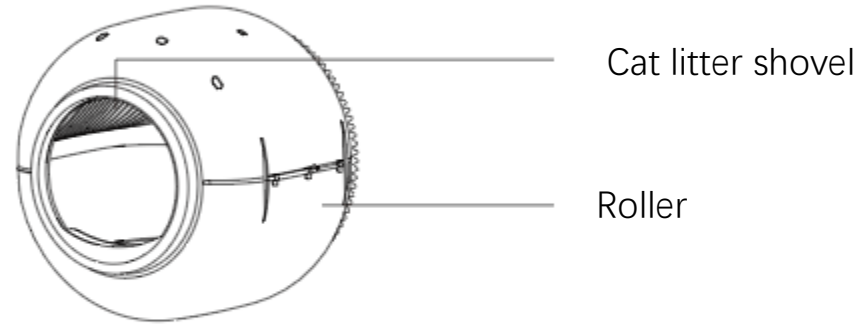
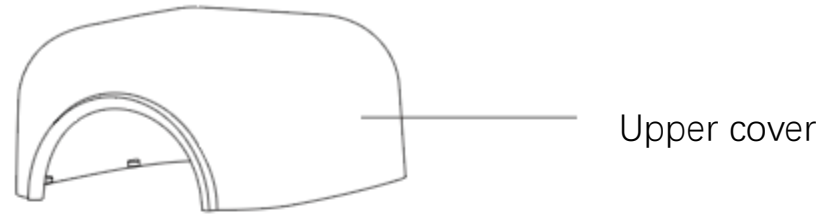

Buttton

Power cord
socket

Feces Collecting
box

Manual for using

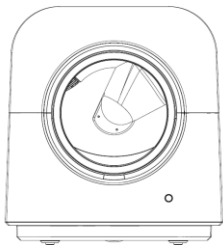

Long press/click/double-click
button
Perform operations

● On/standby mode

After inserting the power supply and powering it on, the machine starts up and enters standby mode (the green light remains on). If it is the first time you start the app, it will prompt for network distribution (green light flashing quickly). After the network is completed, press the button and the green light will stay on to enter standby mode.

● Long Press

Press and hold the button for 10 seconds to restore the original settings. Then enter the distribution network state and waits for the distribution network.

● Click

Click the button to manually execute the cleaning mode once.

Cleaning mode: Clean the excrement and large agglomerated sand in the drum to the collection bin.

● Double-Click

Double click the button to manually execute the sand pouring mode once.

Sand dumping mode: Clean all the waste sand in the drum to the collection bin.

● Button light control

If you need to turn off the button light, you can enter APP Settings Indicator Light to turn it off.

Manual for using

1、 Remove the trash can

Users can take out the toilet bin to the left or right according to their usage habits.

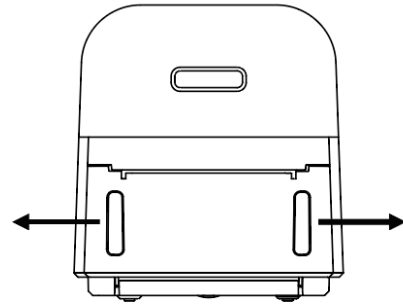

2.Install garbage bags and aromatherapy gel

In the direction shown in the figure, remove the cover of the collection bin, insert the garbage bag into the groove of the collection bin, reinstall the cover of the collection bin into the collection bin, and press the garbage bag tightly to complete the installation of the garbage bag; After opening the packaging of the aromatherapy gel and inserting it into the groove of the toilet cover, the installation of the aromatherapy gel is completed.

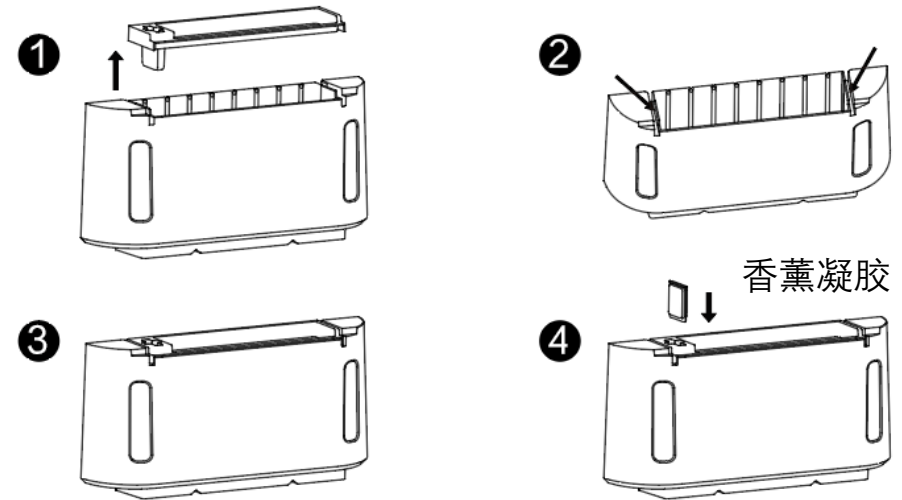

Manual for using

3. Install the collection bin into the base

Users can install the collection bin into the base to the center position to the left or right according to their usage habits.

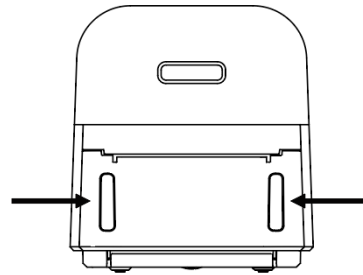

4. Insert power adapter

Insert the power adapter into the power port of the base, and the machine will automatically turn on and enter standby mode.

(When the device is turned on for the first time, it enters the distribution mode and the green light flashes quickly, waiting for the user to connect to the network.)

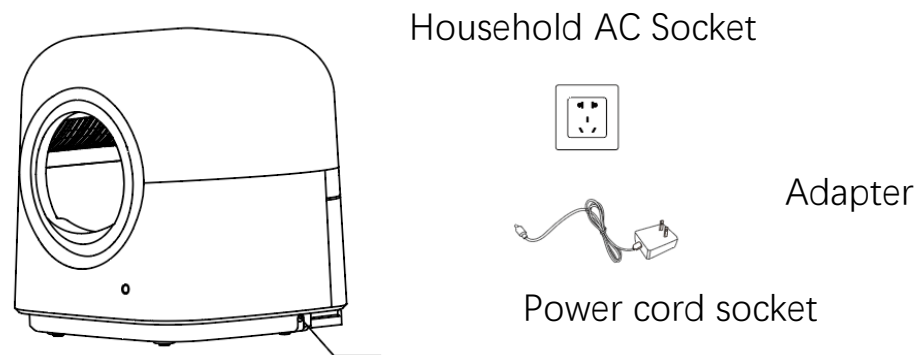

Manual for using

5.Add cat litter

It is recommended to add cat litter to the MAX marking line (the marking line is located at the top of the cat litter cushion adhesive), but it cannot be higher than the MAX marking line. After adding cat litter, the machine will display a blue light that remains on for about 5 minutes, followed by a green light that automatically smooths the litter.

(Note: If the cat litter sand level is low, it will increase the chances of the drum sticking to the wall.)

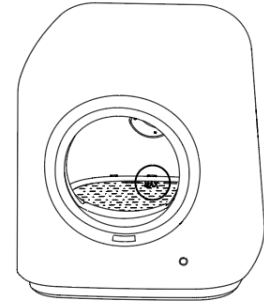

6.Enter Run

The machine can be used standalone or networked.

- ① Single machine operation: After powering on and adding cat litter, it automatically enters single machine mode (only the cleaning mode can be automatically run, and the sterilization mode cannot be used).
- ② Online operation: The network can be distributed according to the following instructions, and the machine can operate fully through the APP after distribution.

●APP control

1. Search for the "TUYA Intelligence" app in major mobile application markets for download and installation, register an account after installation, and log in to the app;
2. Click on "Add Device" on the homepage, open Bluetooth and WiFi on the phone, and ensure that the smart litter tray is in network configuration state (green light flashing). Follow the APP prompts to bind the device;

*Due to the upgrade and update of the APP, the actual operation may differ slightly from the above description. Please follow the instructions in the current APP for operation.

Entering distribution network mode in working mode

Press and hold the button for 10 seconds, the green light will flash quickly, and the machine will enter the distribution network state, waiting for the distribution network.

Manual for APP connecting

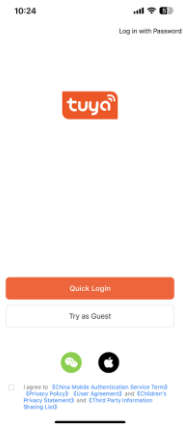

1、 Open the "TUYA Intelligence" app, register and log in;

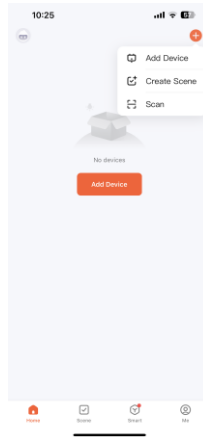

2、 Click the "+" in the upper right corner and then click on "Add Device";



3、 After the APP searches for the device, click on "Add" (ensure that the machine is in distribution mode and the green light flashes quickly)

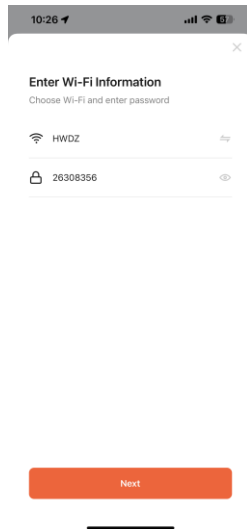

4、 Enter WIFI account and password ;

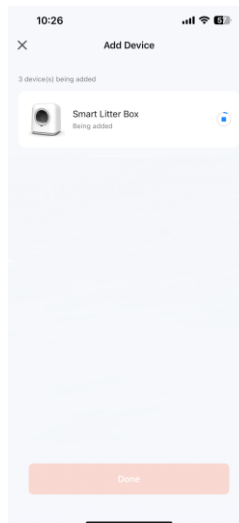

5、 Waiting for device addition to complete ;

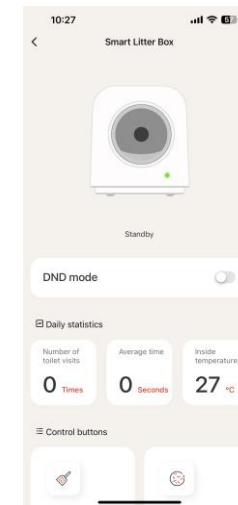

6、 Enter the main page;

Manual For washing

● Roller Cleaning

Before cleaning the roller, please use the sand dumping function to clean the waste sand inside the roller. The disassembly method of the roller is shown in the figure, and the roller can be removed after removing the upper cover. The roller can be wiped with a wet towel. After wiping, it needs to wait for the roller to dry before being put into the base before use.

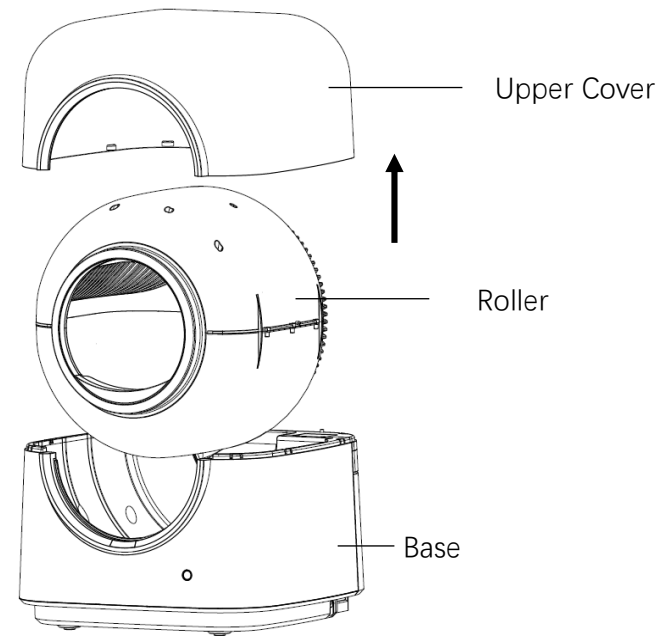

Note: The roller does not need to be aligned when placed in the base, and the machine will automatically roll and return to its original position after placement.

Sterilization instructions

● Sterilization instructions

The sterilization mode can only be activated through the APP, and sterilization can be divided into manual and intelligent sterilization.

① Manual sterilization: Click the "sterilization" button in the APP, and the UV sterilization module will start sterilization of the fecal collection bin for 2 minutes. After completion, it will automatically close.

② Intelligent sterilization: It is enabled in APP Settings - Intelligent sterilization. After being enabled, sterilization is performed on the collection bin every 6 hours, lasting for 2 minutes each time. After completion, it automatically closes.

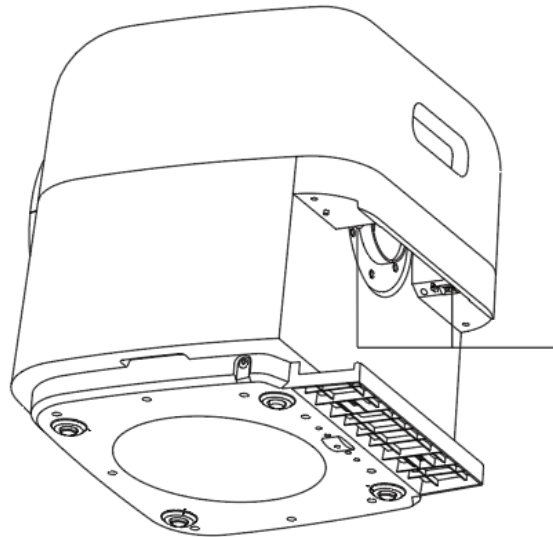

Ultraviolet sterilization

Note: The UV sterilization module is located above the fecal collection bin. Do not open the upper cover or fecal collection bin during sterilization, otherwise the sterilization process will terminate.

Indicator light status description/troubleshooting

Indicator light status	Working condition
Green light always on	Machine standby/cleaning/sand dumping
Green light flashing	Machine prompts for network status
Red light always on	<ol style="list-style-type: none">1. The upper cover and collection bin are not installed in place or the cleaning process is interrupted;2. Urine collection tank full alarm
Red light flashing	The motor stops running due to resistance
Blue light always on	Machine detects cat entering or adding litter
Purple light always on	UV sterilization in progress (sterilization lasting for two minutes each time)

Indicator light status description/troubleshooting

Fault Description	Handling measures
Red light always on	<ol style="list-style-type: none">1. Check if the upper cover or toilet compartment is installed in place;2. Check if there are cats approaching the machine during cleaning or sand dumping Alternatively, enter the machine, and if there is one, the cat will complete the remaining programs after leaving and the green light will remain on.3. Check if the capacity of the collection bin is full. If it is full, please clean it.
Red light flashing	<ol style="list-style-type: none">1. Check whether there are foreign objects stuck in the gear;2. After confirming that there are no foreign objects stuck, power off and restart.
Machine can't connect WIFI	<ol style="list-style-type: none">1. Check if the WiFi password is correct;2. Check if the WiFi frequency is 2.4GHz, and if the WiFi frequency is 5GHz, Please replace the router and try again.
Cat litter pads are prone to sticking	Check if the cat litter is sufficient and add it to the MAX marking position.

Product details Information :

Product Name: Smart Cat litter toilet

Product size: 545X545X595 (H) MM

Rated capacity: approximately 60L

Weight: 13.5kg

Input: DC 12 V 2 A

HANGZHOU TIANYUAN PET PRODUCTS FACTORY

Add: No 10-1, XingLing Road, XingQiaoTown, Linping District, Hangzhou, Zhejiang, China
PC.311106

Tel: 0086-571-28931673

Fax: 0086-571-28887567

E-mail: yhxue@tianyuanpet.com

Website: www.petproducts.com.cn

MADE IN CHINA



Warranty certificate

Warranty terms

During the warranty period, the warranty (free repair) of Yuansu Smart Cat litter products will be implemented from the date of purchase.

1. Products within the warranty period can only be guaranteed at designated service stores; Please present this warranty voucher and purchase invoice during warranty.
2. Within the following period from the date of purchase, warranty will be provided in the event of malfunctions during normal use
3. This warranty clause only applies to occasions where consumers purchase and use it for personal consumption needs, and is not applicable to commercial use.
4. Even during the warranty period, the following situations cannot be treated as warranty, but can be repaired for a fee:
 - a. Failure to use, maintain, or store the product in accordance with the instructions, resulting in damage;
 - b. Damage caused by improper operation, abnormal or damaged power supply (such as falling);
 - c. Damage caused by unauthorized disassembly by service shop maintenance personnel;
 - d. Unable to present this warranty certificate and valid purchase invoice;
 - e. The information recorded on the warranty certificate does not match or is altered with the physical identification of the product;
 - f. Damage caused by force majeure factors such as lightning, earthquake, fire, flood, etc.

- a. The entire machine is free of charge within one year;
- b. The main components [motors, circuit board components, adapters] are free of charge within one year.