

Report on the FCC and ISED Testing of the

Current Products Corp.
CP19CBZ-01

In accordance with FCC 47 CFR Part 15.247 &
ISED Canada's Radio Standards Specifications
RSS-247

Prepared for: Current Products Corp.
1995 Hollywood Ave.
Pensacola, FL 32505

FCC ID: 2AJXX100227 IC: 22151-CP19CBZ01

COMMERCIAL-IN-CONFIDENCE

Document Number: BO72143516.100 | Issue: 01

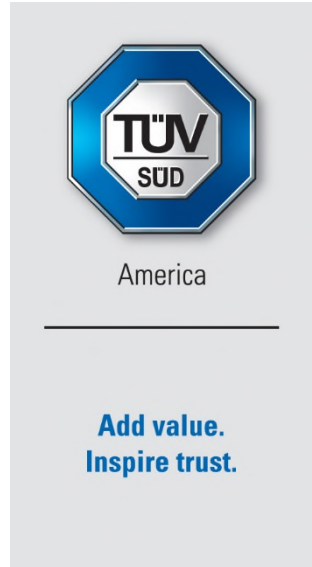

SIGNATURE

NAME	JOB TITLE	RESPONSIBLE FOR	ISSUE DATE
Pete Walsh	Service Line Manager	Authorized Signatory	2019-Jan-10

Signatures in this approval box have checked this document in line with the requirements of TÜV SÜD America, Inc. document control rules.

FCC Accreditation Designation Number US1063 Tampa, FL Test Laboratory	Innovation, Science, and Economic Development Canada Accreditation Main Site Number 2087A-2 Tampa, FL Test Laboratory Satellite Site Number: 4175C Boca Raton, FL Test Laboratory
--	--

EXECUTIVE SUMMARY

A sample of this product was tested and found to be compliant with FCC Part 15.247, ISED Canada's RSS-247



DISCLAIMER AND COPYRIGHT

This non-binding report has been prepared by TÜV SÜD America with all reasonable skill and care. The document is confidential to the potential Client and TÜV SÜD America. No part of this document may be reproduced without the prior written approval of TÜV SÜD America. © TÜV SÜD.

ACCREDITATION

Our A2LA Accreditation does not cover opinions and interpretations and any expressed are outside the scope of our A2LA Accreditation.

TÜV SÜD America
5610 West Sligh Ave., Suite 100
Tampa, FL 33634

Phone: 813-284-2715
www.tuv-sud-america.com

TABLE OF CONTENTS

1	GENERAL	3
1.1	Purpose	3
1.2	Applicant Information	3
1.3	Product Description	3
1.4	Test Methodology and Considerations	3
2	TEST FACILITIES	5
2.1	Location	5
2.2	Laboratory Accreditations/Recognitions/Certifications.....	5
2.3	Radiated & Conducted Emissions Test Site Description	6
2.3.1	Semi-Anechoic Chamber Test Site	6
2.3.2	Conducted Emissions Test Site Description.....	7
3	APPLICABLE STANDARD REFERENCES	8
4	LIST OF TEST EQUIPMENT	9
5	SUPPORT EQUIPMENT	10
6	EQUIPMENT UNDER TEST SETUP BLOCK DIAGRAM.....	11
7	SUMMARY OF TESTS.....	12
7.1	Antenna Requirement – FCC: Section 15.203.....	12
7.2	6 dB Bandwidth - FCC: Section 15.247(a)(2); ISED Canada: RSS-247 5.2(a); 99% Bandwidth ISED Canada: RSS-GEN 6.6.....	12
7.2.1	Measurement Procedure.....	12
7.2.2	Measurement Results	12
7.3	Peak Output Power – FCC: Section 15.247(b)(3); ISED Canada: RSS-247 5.4(d)	17
7.3.1	Measurement Procedure (Conducted Method)	17
7.3.2	Measurement Results	17
7.4	Band-Edge Compliance and Spurious Emissions	19
7.4.1	Band-Edge Compliance of RF Conducted Emissions – FCC: Section 15.247(d); ISED Canada: RSS-247 5.5.....	19
7.4.2	RF Conducted Spurious Emissions – FCC: Section 15.247(d); ISED Canada: RSS-247 5.5...	21
7.4.3	Radiated Spurious Emissions into Restricted Frequency Bands – FCC: Sections 15.205, 15.209; ISED Canada: RSS-Gen 8.9, 8.10	25
7.4.4	Sample Calculation:	26
7.5	Power Spectral Density – FCC: Section 15.247(e); ISED Canada: RSS-247 5.2(b)	27
7.5.1	PSD Measurement Procedure (Conducted Method).....	27
7.5.2	Measurement Results	27
7.6	Power Line Conducted Emissions – FCC: Section 15.207; ISED Canada: RSS-Gen 8.8	29
7.6.1	Measurement Procedure.....	29
7.6.2	Measurement Results	29
8	MEASUREMENT UNCERTAINTIES	33
9	CONCLUSION.....	34

1 GENERAL

1.1 Purpose

The purpose of this report is to demonstrate compliance with Part 15 Subpart C of the FCC's Code of Federal Regulations Section 15.247 and Innovation Science and Economic Development Canada's Radio Standards Specification RSS-247 for the tests documented herein.

1.2 Applicant Information

Current Products Corp.
1995 Hollywood Ave.
Pensacola, FL 32505

1.3 Product Description

The Current Products Corp. model CP19CBZ-01 is a rod drapery that has a motor inside the tube with a cable going to an external housing that holds a board inside. Coming down from the housing is a cable that attaches to a battery tube that can be pulled down or lifted up to manually control the drapery. The battery tube can either have 6 alkaline batteries, 2 different rechargeable batteries, or be configured to have a low voltage adapter plugged in. The device includes a 2.4 GHz Zigbee transceiver.

Technical Details

Mode of Operation: IEEE 802.15.4
Frequency Range: 2405 - 2480 MHz
Number of Channels: 16
Channel Separation: 5
Data Rate: 250 kbps
Modulations: O-QPSK
Antenna Type/Gain: Monopole, 5.19 dBi
Input Power: 7VDC - 12 VDC (Power supply and type D Batteries)

Model Number: CP19CBZ-01

Test Sample Serial Number(s): BR-385889-1 Radiated Emissions, BR-385889-4 RF Conducted Emissions

Test Sample Condition: The test samples were in good operating condition without any physical damages.

1.4 Test Methodology and Considerations

The EUT was evaluated for RF Conducted, radiated and power line conducted emissions. The power settings used during the evaluation are provided below:

Channel 11: Power 15
Channel 18: Power 15
Channel 26: Power 13

For the radiated emissions, the EUT was evaluated in the orientation of typical installation.

The RF conducted emission measurements were performed on the transceiver PCB which was modified with a temporary connector to allow direct coupling to the spectrum analyzer.

The power line conducted emissions measurements were performed on multiple power supply configurations. The results are provided for the overall worst-case.

The EUT was also evaluated for compliance to the unintentional emissions requirements. The results are documented in a supplier's declaration of conformity test report.

2 TEST FACILITIES

2.1 Location

The radiated and conducted emissions test sites are located at the following address:

TÜV SÜD America, Inc.
3998 FAU Blvd, Suite 310
Boca Raton, Florida 33431
Phone: (561) 961-5585
Fax: (561) 961-5587
<http://www.tuv-sud-america.com>

Innovation, Science and Economic Development Canada Lab Code: 4175C

2.2 Laboratory Accreditations/Recognitions/Certifications

TÜV SÜD America, Inc. is accredited to ISO/IEC 17025 by American Association for Laboratory Accreditation (A2LA) and has been issued certificate number 2955.15 in recognition of this accreditation. Unless otherwise specified, all test methods described within this report are covered under the ISO/IEC 17025 scope of accreditation.

Main Site Information:

TÜV SÜD America, Inc.
5610 West Sligh Ave., Suite 100
Tampa, FL 33634
Phone: 813-284-2715
www.tuv-sud-america.com

FCC Designation Number US1063
FCC Test Firm Registration #: 160606
Innovation, Science, and Economic Development Canada Lab Code: 2087A-2

2.3 Radiated & Conducted Emissions Test Site Description

2.3.1 Semi-Anechoic Chamber Test Site

The EMC radiated test facility consists of an RF-shielded enclosure. The interior dimensions of the indoor semi-anechoic chamber are approximately 48 feet (14.6 m) long by 36 feet (10.8 m) wide by 24 feet (7.3 m) high and consist of rigid, 1/8 inch (0.32 cm) steel-clad, wood core modular panels with steel framing. In the shielded enclosure, the faces of the panels are galvanized, and the chamber is self-supporting. 8-foot RF absorbing cones are installed on 4 walls and the ceiling. The steel-clad ground plane is covered with vinyl flooring.

The turntable is driven by pneumatic motor, which can support a 2000 lb. load. The turntable is flush with the chamber floor which it is connected to, around its circumference, with a continuous metallic loaded spring. An EMCO Model 1060 Multi-device controller controls the turntable position.

A pneumatic motor is used to control antenna polarizations and height relative to the ground. The height information is displayed on the control unit EMCO Model 1050.

The control room is an RF shielded enclosure attached to the semi-anechoic chamber with two bulkhead panels for connecting RF, and control cables. The dimension of the room is 7.3 m x 4.9 m x 3 m high and the entrance doors of both control and conducted rooms are 3 feet (0.91 m) by 7 feet (2.13 m).

A diagram of the Semi-Anechoic Chamber Test Site is shown in Figure 2.3.1-1 below:

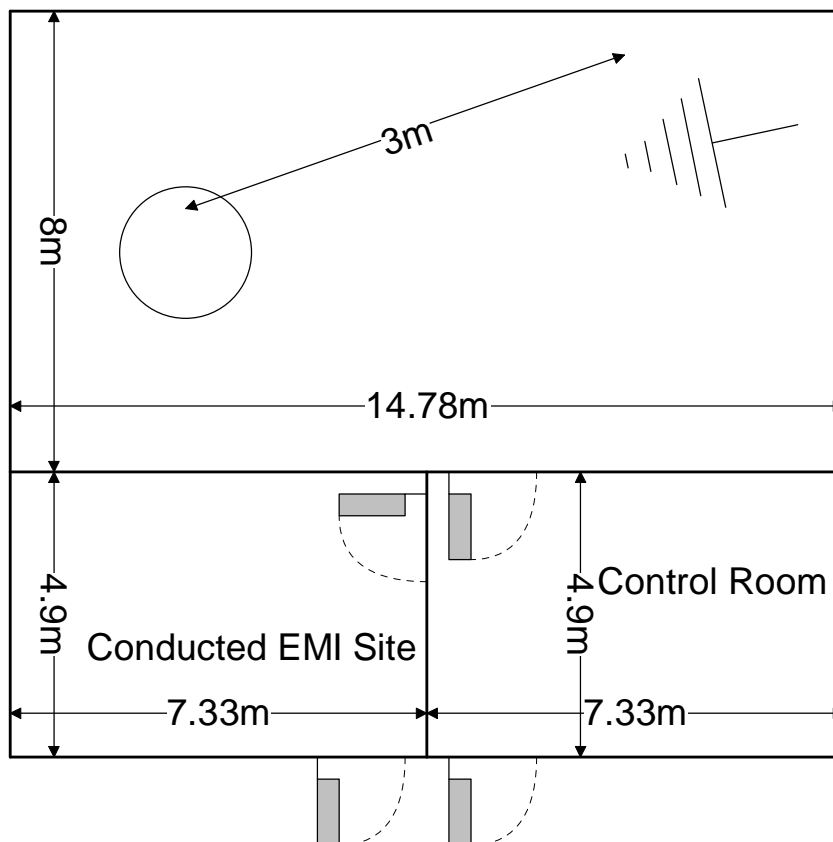

Figure 2.3.1-1: Semi-Anechoic Chamber Test Site

2.3.2 Conducted Emissions Test Site Description

The dimensions of the shielded conducted room are 7.3 x 4.9 x 3 m³. The power line conducted emission site includes two LISNs: a Solar Model 8028-50 50 Ω/50 μH and an EMCO Model 3825/2R, which are installed as shown in the figure below. For evaluations requiring 230 V, 50 Hz AC input, a Polarad LISN (S/N 879341/048) is used in conjunction with a California Instruments signal generator Model 2001RP-OP1.

A diagram of the room is shown below in figure 2.3.2-1:

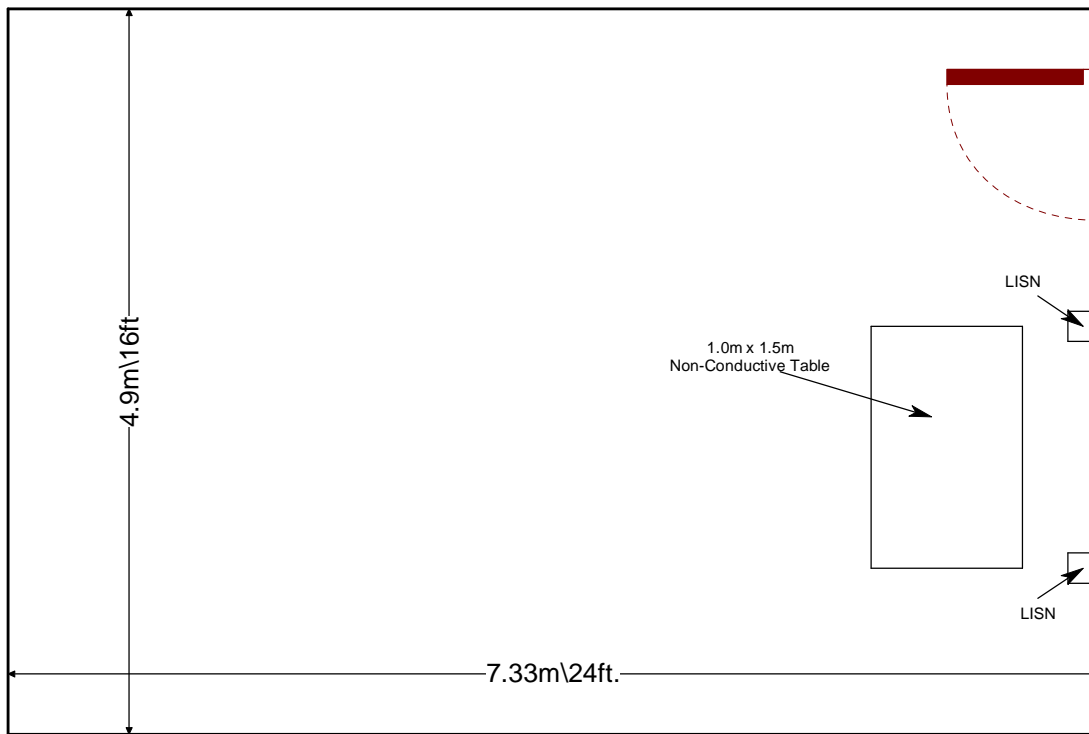

Figure 2.3.2-1: AC Mains Conducted EMI Site

3 APPLICABLE STANDARD REFERENCES

The following standards were used:

- ❖ ANSI C63.10-2013: American National Standard of Procedures for Compliance Testing of Unlicensed Wireless Devices
- ❖ US Code of Federal Regulations (CFR): Title 47, Part 2, Subpart J: Equipment Authorization Procedures, 2018.
- ❖ US Code of Federal Regulations (CFR): Title 47, Part 15, Subpart C: Radio Frequency Devices, Intentional Radiators, 2018
- ❖ FCC KDB 558074 D01 DTS Meas Guidance v05 - Guidance for Performing Compliance Measurements on Digital Transmission System, Frequency Hopping Spread Spectrum System, and Hybrid System Devices Operating Under Section 15.257 of the FCC Rules, August 24, 2018.
- ❖ Innovation, Science and Economic Development Canada Radio Standards Specification: RSS-247 — Digital Transmission Systems (DTSs), Frequency Hopping Systems (FHSs) and Licence-Exempt Local Area Network (LE-LAN) Devices, Issue 2, February 2017.
- ❖ Innovation, Science and Economic Development Canada Radio Standards Specification: RSS-GEN – General Requirements for Compliance of Radio Apparatus, Issue 4, Amendment 1, March 2018.

4 LIST OF TEST EQUIPMENT

The calibration interval of test equipment is annually or the manufacturer's recommendations. Where the calibration interval deviates from the annual cycle based on the instrument manufacturer's recommendations, it shall be stated below.

Table 4-1: Test Equipment List

AssetID	Manufacturer	Model #	Equipment Type	Serial #	Calibration Performed Date	Calibration Due Date
BEMC00078	EMCO	6502	Active Loop Antenna	9104-2608	5/9/2018	5/9/2020
BEMC00282	Microwave Circuits	H3G020G4	2-20GHz Band Pass Filter	74541	5/17/2018	5/17/2019
BEMC00283	Rohde & Schwarz	FSP40	Spectrum Analyzer	1000033	11/28/2017	11/28/2019
BEMC00523	Agilent	E7405A	9kHz-26.5GHz EMC analyzer/HYZ	MY45103293	12/9/2016	12/9/2018
BEMC00653	Suhner	SF-102A	Cable (40GHz)	0944/2A	10/9/2018	10/9/2019
BEMC02002	EMCO	3108	30 MHz to 200 MHz Biconical Antenna	2147	11/28/2017	11/30/2019
BEMC02004	EMCO	3146	200 MHz to 1 GHz Log Periodic Antenna	1385	12/27/2017	12/27/2019
BEMC02006	EMCO	3115	Linear Polarized Horn antenna, 1-18 GHz	2573	4/7/2017	4/7/2019
BEMC02008	COM-power	AH-826	Horn Antenna (18 GHz to 26.5 GHz)	81009	NCR	NCR
BEMC02011	Hewlett-Packard	HP 8447D	100 kHz to 1.3 GHz low-noise, high gain amplifier	2443A03952	10/18/2018	10/18/2019
BEMC02022	EMCO	LISN3825/2R	Line Impedance Stabilization Network	1095	9/28/2017	9/28/2019
BEMC02045	ACS Boca	Conducted Cable Set	Consists of cables 2046, 2047, 2062, 2063 and 2065	2045	10/22/2018	10/22/2019
BEMC02086	Merrimac	FAN-6-10K	10dB Attenuator	23148-83-1	10/17/2018	10/17/2019
BEMC02095	ETS Lindgren	TILE4! - Version 4.2.A	Tile Automation Software	85242	NCR	NCR
BEMC02111	Aeroflex Inmet	40AH2W-20	Attenuator 20dB, 2.9 mm-M/F, DC-40GHz 2 W	2111	8/5/2018	8/5/2019
BEMC02112	Teledyne Storm Products	921-0101-036	Duratest High Frequency Cable Max. frequency 26.5GHz	12-06-698	10/16/2018	10/16/2019
BEMC02121	Teledyne Storm Products	A81-0303	Radiated Cable Set	2121	7/26/2018	7/26/2019
BEMC02138	Hewlett Packard	8449B	Pre-Amplifier	3008A00320	11/26/2018	11/26/2019
BEMC03004	Teseq	CFL 9206A	Transient Filter Limiter 9kHz - 30MHz	34720	8/10/2018	8/10/2019
TEMC00171	MegaPhase, LLC	1GVT4	4A & 4B Test Cables	NC12-K1K1-59, 394	5/30/2018	5/30/2020

Notes:

- **NCR=No Calibration Required**
- **The assets were only used during the active period of the calibration cycle.**

5 SUPPORT EQUIPMENT

Table 5-1: EUT and Support Equipment Description – Radiated Emissions

Item #	Type Device	Manufacturer	Model/Part #	Serial #
1	EUT	Current Products Corp.	CP19CBZ-01	BR-385889-1
2	Rod Motor	Current Products Corp.	N/A	N/A
3	Rod Motor	Current Products Corp.	N/A	N/A
4	2x Ferrite	FAIR-RITE	0431164281	N/A
5	Battery Tube	Current Products Corp.	N/A	N/A
6	2x Ferrite	FAIR-RITE	0431167281	N/A
7	9 VDC Power Supply	N/A	DNK-0903000	N/A

Table 5-2: Cable Description – Radiated Emissions

Cable #	Cable Type	Length	Shield	Termination
A	Power Cable	0.35 m	Yes	EUT to Rod Motor
B	Power Cable	0.35 m	Yes	EUT to Rod Motor
C	Power Cable	0.65 m	No	EUT to Battery Tube
D	Power Cable	1.9 m	No	Power Supply to Battery Tube
E	Extension Cord	2.73 m	No	Power Supply to AC Mains

Table 5-3: EUT and Support Equipment Description – Power Line Conducted Emissions

Item #	Type Device	Manufacturer	Model/Part #	Serial #
1	EUT	Current Products Corp.	CP19CBZ-01	BR-385889-1
2	Rod Motor	Current Products Corp.	N/A	N/A
3	Rod Motor	Current Products Corp.	N/A	N/A
4	Ferrite	FAIR-RITE	0431164281	N/A
5	Battery Tube	Current Products Corp.	N/A	N/A
6	Ferrite	FAIR-RITE	0431164281	N/A
7	8.4 VDC Power Supply	DSS	DSS12D-0841000-E	N/A

Table 5-4: Cable Description – Power Line Conducted Emissions

Cable #	Cable Type	Length	Shield	Termination
A	Power Cable	0.35 m	Yes	EUT to Rod Motor
B	Power Cable	0.35 m	Yes	EUT to Rod Motor
C	Power Cable	0.65 m	No	EUT to Battery Tube
D	Power Cable	1.9 m	No	Power Supply to Battery Tube
E	Extension Cord	2.73 m	No	Power Supply to AC Mains

6 EQUIPMENT UNDER TEST SETUP BLOCK DIAGRAM

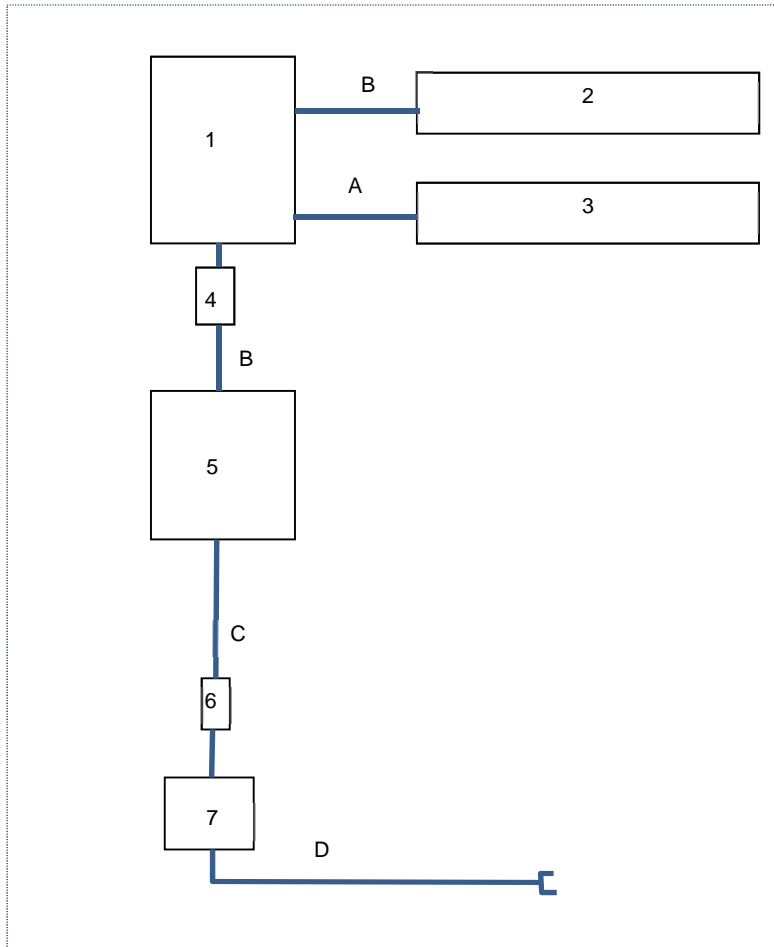

Figure 6-1: EUT and Support Equipment Block Diagram

7 SUMMARY OF TESTS

Along with the tabular data shown below, plots were taken of all signals deemed important enough to document.

Test Begin Date: November 9, 2018

Test End Date: December 7, 2018

Table 7-1: Summary of Tests

Requirements	FCC Rule Part	ISED Canada	Test Results
Antenna Requirement	FCC: Section 15.203		Pass
6 dB Bandwidth	FCC: Section 15.247(a)(2)	ISED Canada: RSS-247 5.2(a)	Pass
99% Bandwidth		ISED Canada: RSS-GEN 6.6	Pass
Peak Output Power	FCC: Section 15.247(b)(3)	ISED Canada: RSS-247 5.4(d)	Pass
Band-Edge Compliance of RF Conducted Emissions	FCC: Section 15.247(d)	ISED Canada: RSS-247 5.5	Pass
RF Conducted Spurious Emissions	FCC: Section 15.247(d)	ISED Canada: RSS-247 5.5	Pass
Radiated Spurious Emissions into Restricted Frequency Bands	FCC: Sections 15.205, 15.209	ISED Canada: RSS-Gen 8.9, 8.10	Pass
Power Spectral Density	FCC: Section 15.247(e)	ISED Canada: RSS-247 5.2(b)	Pass
Power Line Conducted Emissions	FCC: Section 15.207	ISED Canada: RSS-Gen 8.8	Pass

7.1 Antenna Requirement – FCC: Section 15.203

The EUT uses a 5.19 dBi whip antenna which is directly soldered to its PCB. The antenna is not readily removable and therefore meets the requirements of FCC Section 15.203.

7.2 6 dB Bandwidth - FCC: Section 15.247(a)(2); ISED Canada: RSS-247 5.2(a); 99% Bandwidth ISED Canada: RSS-GEN 6.6

7.2.1 Measurement Procedure

The 6dB bandwidth was measured in accordance with ANSI C63.10 Subclause 11.8.1 Option 1. The RBW of the spectrum analyzer was set to 100 kHz and VBW 300 kHz. Span was set large enough to capture the emissions and >> RBW. A peak detector was used for the measurements.

The 99% occupied bandwidth was measured with the spectrum analyzer span set to fully display the emission. The RBW was set to 1% to 5% of the approximated bandwidth. The occupied 99% bandwidth was measured by using 99% bandwidth equipment function of the spectrum analyzer using a peak detector.

7.2.2 Measurement Results

Performed by: Thierry Jean-Charles

Table 7.2.2-1: 6dB / 99% Bandwidth

Frequency (MHz)	6dB Bandwidth (kHz)	99% Bandwidth (kHz)
2405	1701.25	2231.25
2440	1705.00	2235.00
2480	1695.00	2242.50

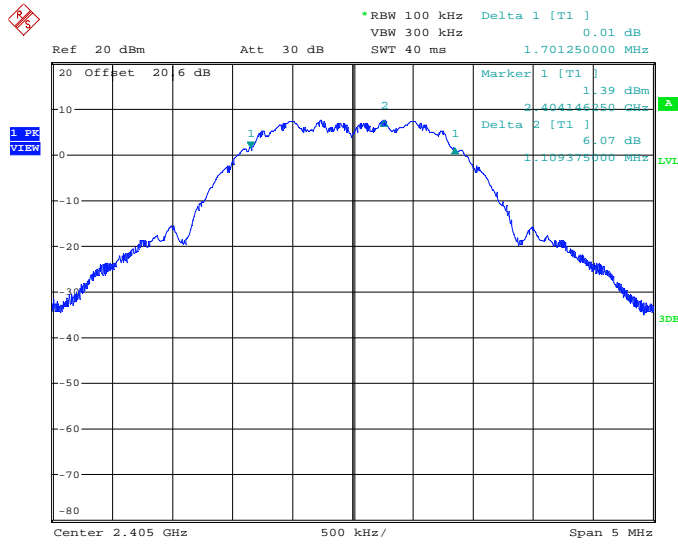

Date: 7.DEC.2018 16:20:02

Figure 7.2.2-1: 6dB BW - Low Channel

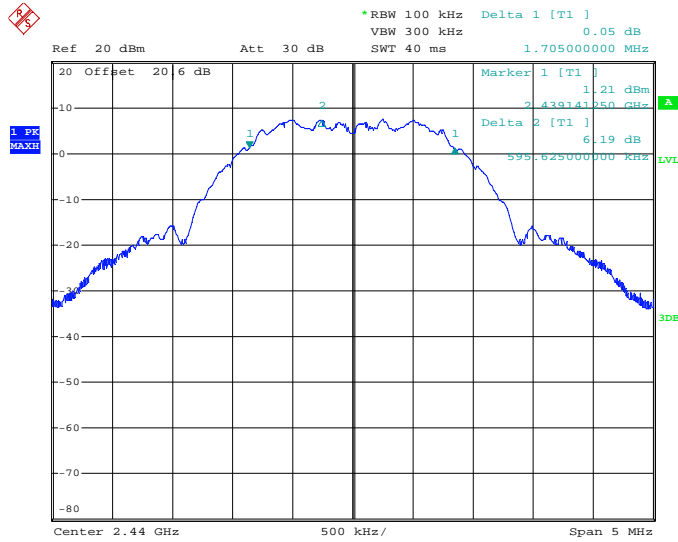

Date: 7.DEC.2018 16:53:38

Figure 7.2.2-2: 6dB BW - Middle Channel

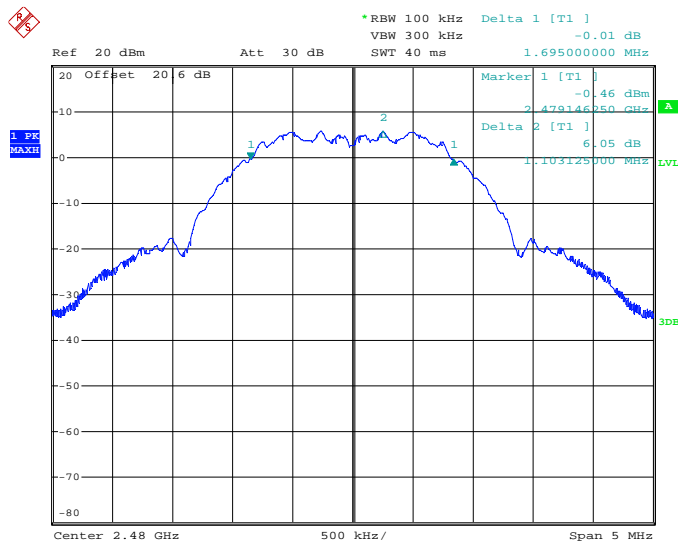

Date: 7.DEC.2018 18:07:16

Figure 7.2.2-3: 6dB BW - High Channel

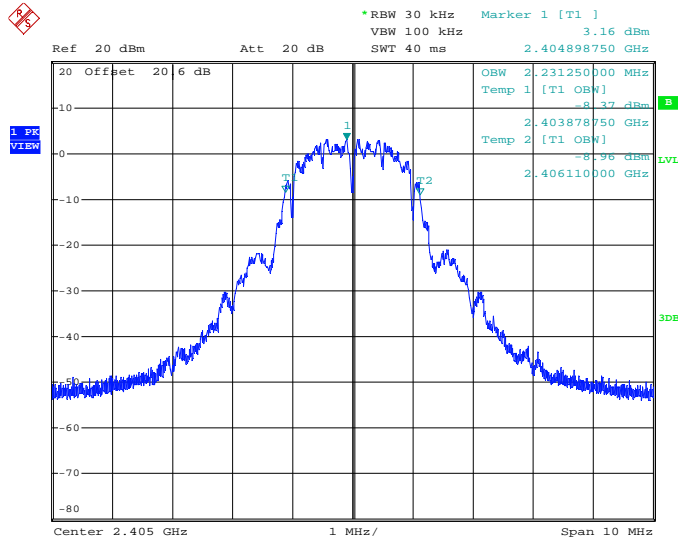

Date: 7.DEC.2018 16:43:30

Figure 7.2.2-4: 99% OBW - Low Channel

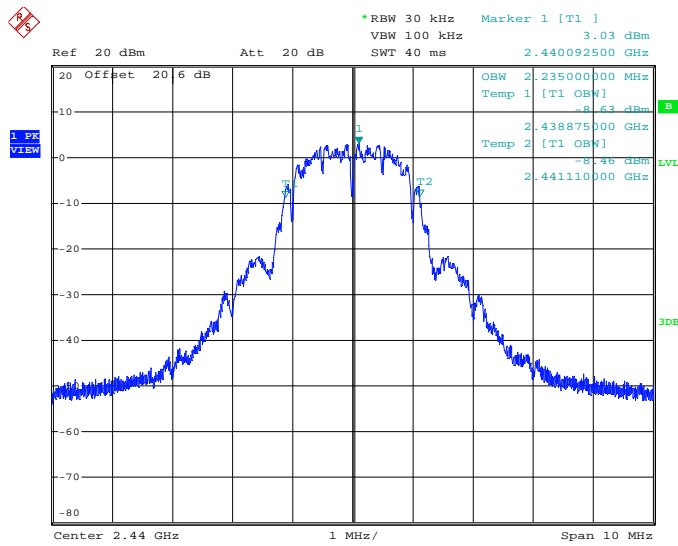

Date: 7.DEC.2018 16:46:32

Figure 7.2.2-5: 99% OBW - Middle Channel

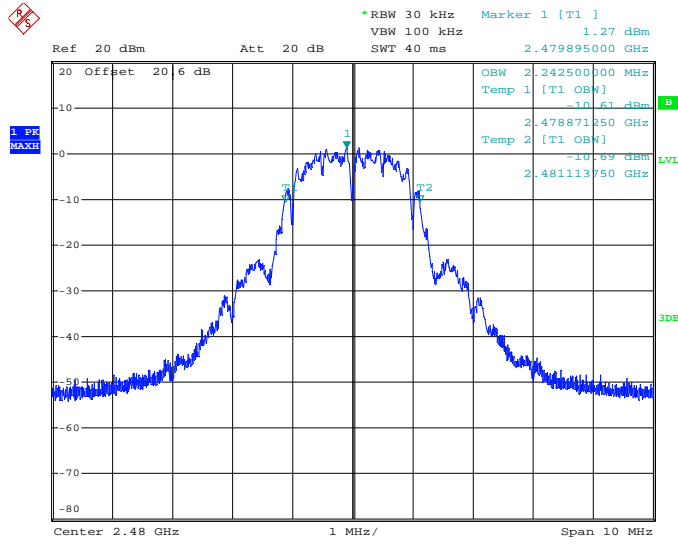

Date: 7.DEC.2018 17:39:29

Figure 7.2.2-6 99% OBW - High Channel

7.3 Peak Output Power – FCC: Section 15.247(b)(3); ISED Canada: RSS-247 5.4(d)

7.3.1 Measurement Procedure (Conducted Method)

The fundamental emission output power was measured in accordance with ANSI C63.10 Subclause 11.9.1.1 RBW \geq DTS bandwidth. The RF output of the equipment under test was directly connected to the input of the spectrum analyzer through suitable attenuation.

The Maximum Output Power allowed is 1 Watt (30 dBm)

7.3.2 Measurement Results

Performed by: Thierry Jean-Charles

Table 7.3.2-1: RF Output Power

Frequency (MHz)	Power (dBm)
2405	11.89
2440	11.79
2480	9.99

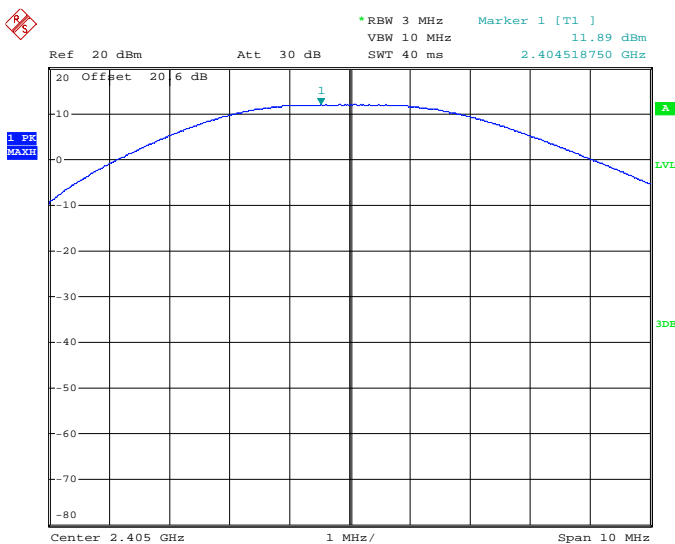

Date: 7.DEC.2018 16:26:20

Figure 7.3.2-1: RF Output Power - Low Channel

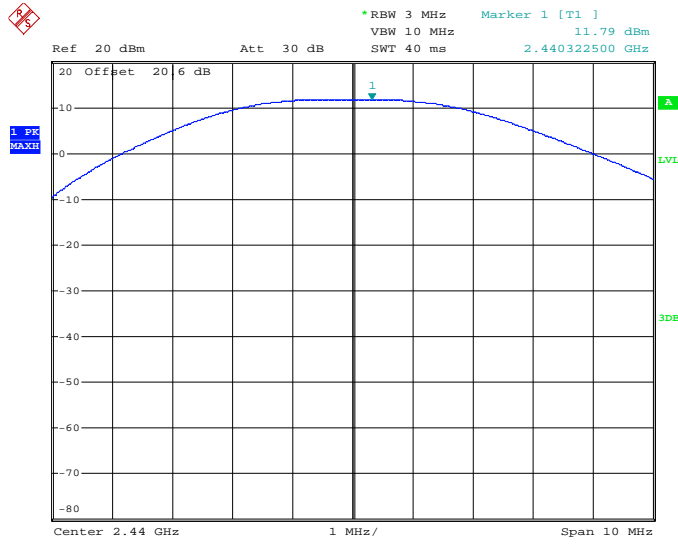

Date: 7.DEC.2018 17:03:49

Figure 7.3.2-2: RF Output Power - Middle Channel

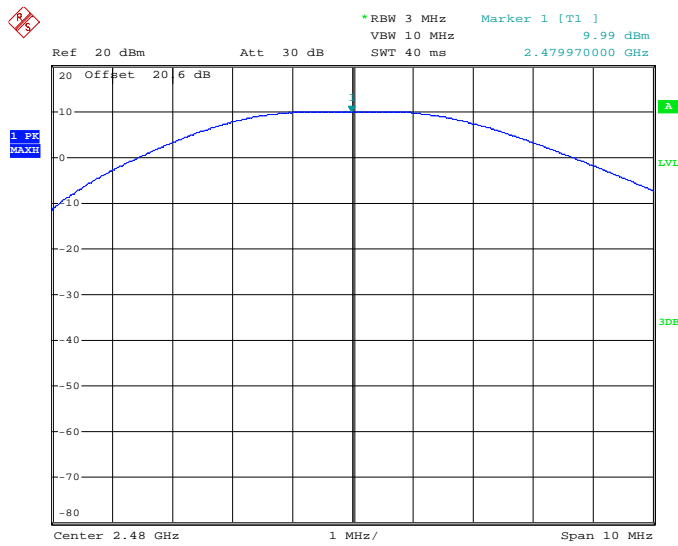

Date: 7.DEC.2018 18:15:55

Figure 7.3.2-3: RF Output Power - High Channel

7.4 Band-Edge Compliance and Spurious Emissions

7.4.1 Band-Edge Compliance of RF Conducted Emissions – FCC: Section 15.247(d); ISED Canada: RSS-247 5.5

7.4.1.1 Measurement Procedure

The RF Conducted Emissions at the Band-Edges were measured in accordance with Subclause 11.11 of ANSI C63.10. The RF output port of the EUT was connected to the input of the spectrum analyzer through suitable attenuation. The EUT was investigated at the lowest and highest channel available to determine band-edge compliance. For each measurement the spectrum analyzer’s RBW was set to 100 kHz, and the VBW was set to >= 300 kHz.

7.4.1.2 Measurement Results

Performed by: Thierry Jean-Charles

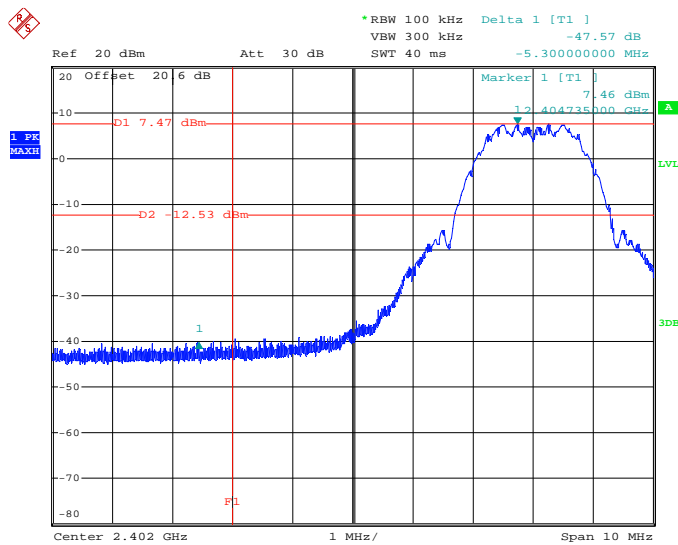

Date: 7.DEC.2018 16:30:13

Figure 7.4.1.2-1: Lower Band-Edge

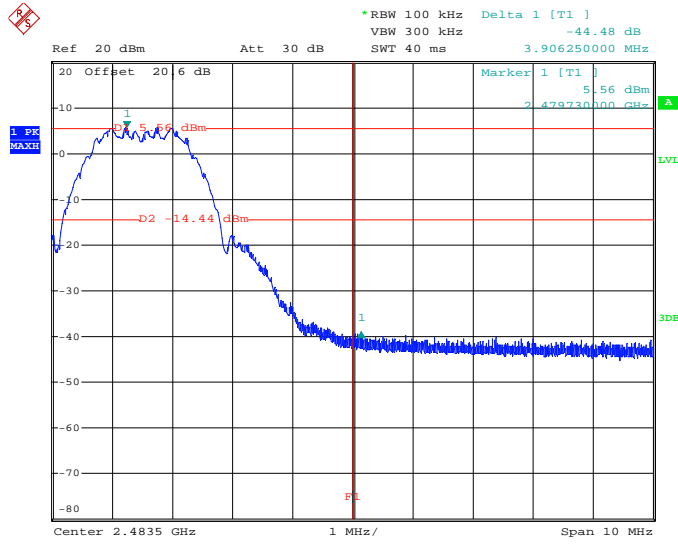

Date: 7.DEC.2018 18:21:50

Figure 7.4.1.2-2: Upper Band-Edge

7.4.2 RF Conducted Spurious Emissions – FCC: Section 15.247(d); ISED Canada: RSS-247 5.5

7.4.2.1 Measurement Procedure

The RF Conducted Spurious Emissions were measured in accordance with Subclause 11.11 of ANSI C63.10. The RF output port of the equipment under test was directly connected to the input of the spectrum analyzer. The EUT was investigated for conducted spurious emissions from 30 MHz to 26 GHz, 10 times the highest fundamental frequency. Measurements were made at the low, center and high channels of the EUT. For each measurement, the spectrum analyzer’s RBW was set to 100 kHz and the VBW was set to 300 kHz. The peak Max Hold function of the analyzer was utilized.

7.4.2.2 Measurement Results

Performed by: Thierry Jean-Charles

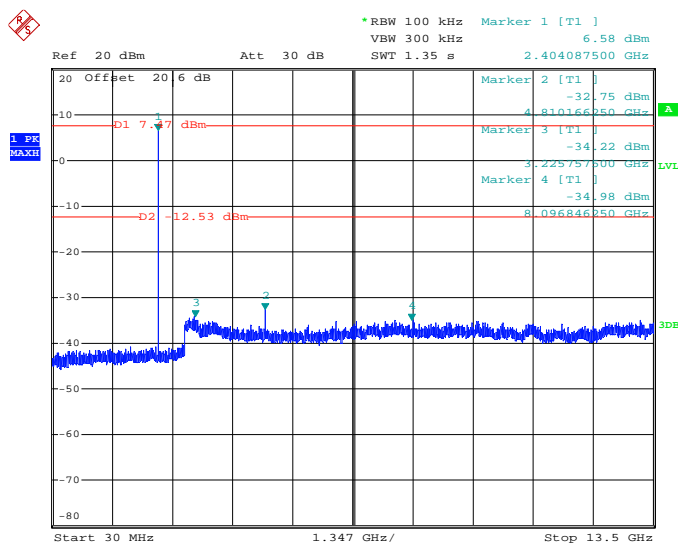

Date: 7.DEC.2018 16:37:04

Figure 7.4.2.2-1: 30 MHz – 13.5 GHz – Low Channel

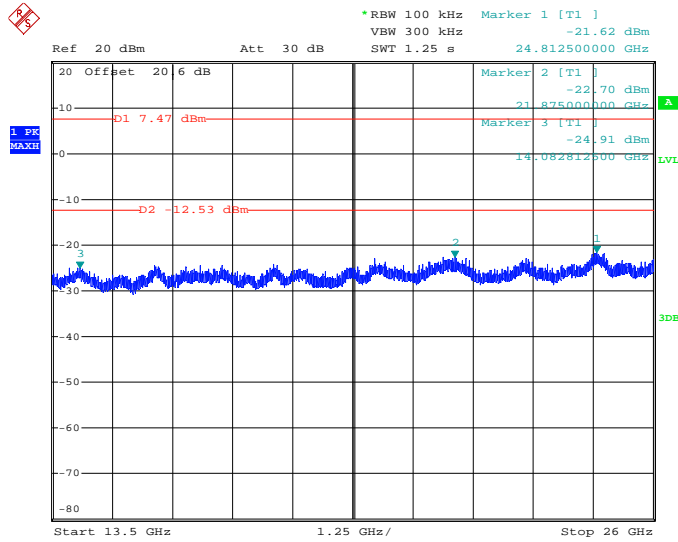

Date: 7.DEC.2018 16:40:20

Figure 7.4.2.2-2: 13.5 GHz – 26 GHz – Low Channel

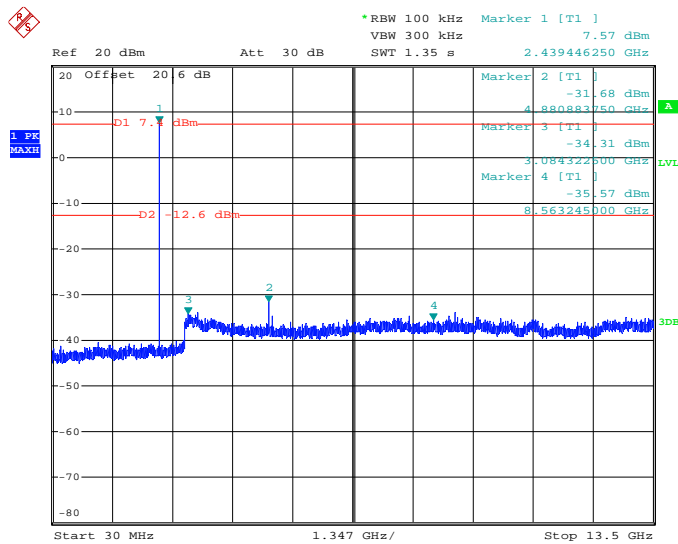

Date: 7.DEC.2018 17:16:51

Figure 7.4.2.2-3: 30 MHz – 13.5 GHz – Middle Channel

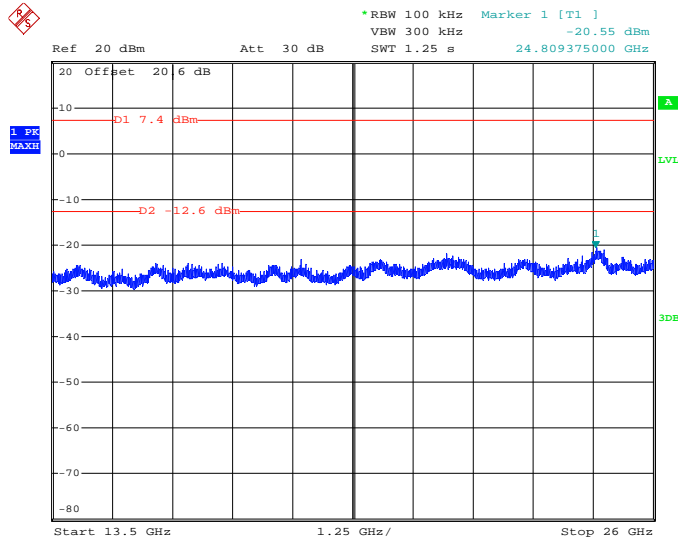

Date: 7.DEC.2018 17:30:43

Figure 7.4.2.2-4: 13.5 GHz – 26 GHz – Middle Channel

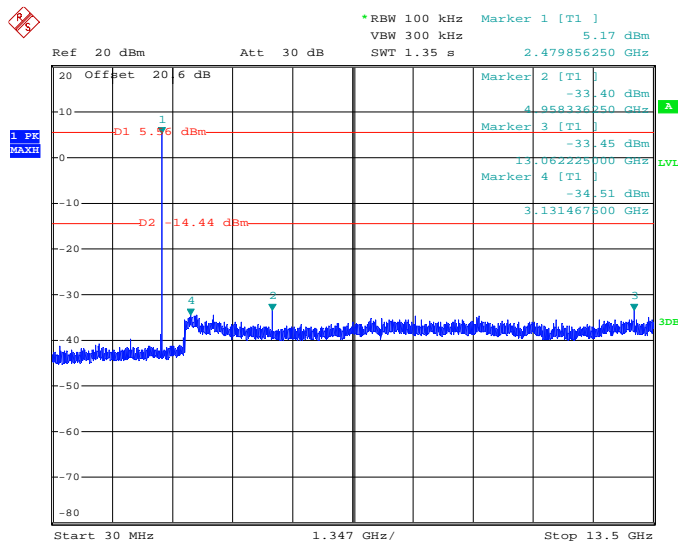

Date: 7.DEC.2018 18:28:35

Figure 7.4.2.2-5: 30 MHz – 13.5 GHz – High Channel

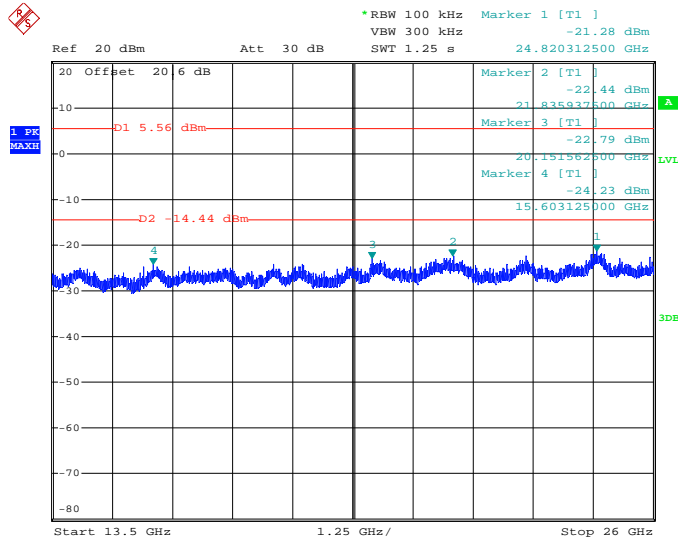

Date: 7.DEC.2018 18:32:10

Figure 7.4.2.2-6: 13.5 GHz – 26 GHz – High Channel

7.4.3 Radiated Spurious Emissions into Restricted Frequency Bands – FCC: Sections 15.205, 15.209; ISED Canada: RSS-Gen 8.9, 8.10

7.4.3.1 Measurement Procedure

Radiated emissions tests were made over the frequency range of 9 kHz to 26 GHz, 10 times the highest fundamental frequency. Each emission found to be in a restricted band as defined by section 15.205, including any emission at the operational band-edge, was compared to the radiated emission limits as defined in Section 15.209.

For measurements below 30 MHz, the receive antenna height was set to 1 m and the EUT was rotated through 360 degrees. The resolution bandwidth was set to 200 Hz below 150 kHz and to 9 kHz above 150 kHz.

The EUT was rotated through 360° and the receive antenna height was varied from 1m to 4m so that the maximum radiated emissions level would be detected. For frequencies below 1000 MHz, quasi-peak measurements were made using a resolution bandwidth RBW of 120 kHz and a video bandwidth VBW of 300 kHz. For frequencies above 1000 MHz, peak measurements are made with RBW of 1 MHz and VBW of 3 MHz. Average measurements are performed in the linear scale using VBW of 30 Hz.

7.4.3.2 Duty Cycle Correction

The EUT was configured to transmit at 100% duty cycle during the evaluation. A Duty Cycle Correction of 66.1% corresponding to $20 \cdot \log(66.1/100) = -3.6$ dB was applied to the average measurements for the corrected average results.

The maximum duty cycle of the EUT is inherent to the IEEE 802.15.4 protocol and is not accessible to the end user. A detailed justification for the duty cycle corrections is provided below:

IEEE 802.15.4-2003 2.4 GHz PHY Constants

Data Rate	250000	bits / sec
	31250	bytes / sec
Symbols/byte	2	sym / bytes
Symbol Timing	62500	sym / sec
	0.000016	sec / sym
Byte Timing	0.000032	sec / byte
PHY PSDU	6	bytes
Max Length	127	bytes
Total Packet Length	133	bytes
Maximum Time TX PKT	0.004256	sec

NOT Transmit time (RX or Idle)

Wait for ACK (tack)	0.000192	sec
RX Time (ACK)	0.000352	sec
Backoff Time (tbo)	0.00112	sec
CPU Processing (tcpu)	0.0002	sec
CCA Assessment (tcca)	0.000128	sec
Turn Around Time (RX to TX)	0.000192	sec
Total Off Time	0.002184	sec

$$\text{Duty Cycle} = 0.004256 / (0.004256 + 0.002184) = 66.09\%$$

7.4.3.3 Measurement Results

Performed by: Jean Rene

Radiated band-edge and spurious emissions found in the restricted frequency bands of 9 kHz to 26 GHz are reported in the tables below.

Table 7.4.3.3-1: Radiated Spurious Emissions Tabulated Data

Frequency (MHz)	Level (dBuV)		Antenna Polarity (H/V)	Correction Factors (dB)	Corrected Level (dBuV/m)		Limit (dBuV/m)		Margin (dB)	
	pk	Qpk/Avg			pk	Qpk/Avg	pk	Qpk/Avg	pk	Qpk/Avg
Low Channel 2405 MHz										
2390	50.72	37.51	V	0.69	51.41	34.60	74.0	54.0	22.6	19.4
4810	50.61	43.15	H	8.06	58.67	47.61	74.0	54.0	15.3	6.4
4810	55.08	48.24	V	8.06	63.14	52.70	74.0	54.0	10.9	1.3
Middle Channel 2440 MHz										
4880	49.99	42.46	H	8.35	58.34	47.22	74.0	54.0	15.7	6.8
4880	55.06	48.01	V	8.35	63.41	52.77	74.0	54.0	10.6	1.2
7320	40.50	26.95	H	13.12	53.62	36.47	74.0	54.0	20.4	17.5
7320	45.09	34.53	V	13.12	58.21	44.05	74.0	54.0	15.8	10.0
High Channel 2480 MHz										
2483.5	62.34	54.17	H	0.94	63.28	51.52	74.0	54.0	10.7	2.5
2483.5	63.79	55.14	V	0.94	64.73	52.49	74.0	54.0	9.3	1.5
4960	49.06	41.46	H	8.69	57.75	46.55	74.0	54.0	16.3	7.4
4960	53.95	46.97	V	8.69	62.64	52.06	74.0	54.0	11.4	1.9
7440	40.30	25.93	H	13.45	53.75	35.78	74.0	54.0	20.3	18.2
7440	43.18	31.60	V	13.45	56.63	41.45	74.0	54.0	17.4	12.6

Notes:

- All emissions above 7.44 GHz were attenuated below the limits and the noise floor of the measurement equipment.
- The average levels were further corrected using a duty cycle correction factor of $20 \cdot \log(66.1/100) = -3.6$ dB

7.4.4 Sample Calculation:

$$R_C = R_U + CF_T$$

Where:

CF_T	=	Total Correction Factor (AF+CA+AG)-DC (Average Measurements Only)
R_U	=	Uncorrected Reading
R_C	=	Corrected Level
AF	=	Antenna Factor
CA	=	Cable Attenuation
AG	=	Amplifier Gain
DC	=	Duty Cycle Correction Factor

Example Calculation: Peak

Corrected Level: $50.72 + 0.69 = 51.41$ dB μ V/m

Margin: 74 dB μ V/m – 51.41 dB μ V/m = 22.59 dB

Example Calculation: Average

Corrected Level: $37.51 + 0.69 - 3.6 = 34.60$ dB μ V/m

Margin: 54 dB μ V/m – 34.60 dB μ V/m = 19.40 dB

7.5 Power Spectral Density – FCC: Section 15.247(e); ISED Canada: RSS-247 5.2(b)

7.5.1 PSD Measurement Procedure (Conducted Method)

The power spectral density was measured in accordance with ANSI C63.10 Subclause 11.10.2 Method PKPSD (peak PSD). The RF output port of the EUT was directly connected to the input of the spectrum analyzer. Offset values were input for cable and external attenuation. The spectrum analyzer RBW was set to 3 kHz and VBW to 10 kHz. The Span was adjusted to 1.5 times the DTS bandwidth and the sweep time was set to auto. The measurements were performed using a Peak detector.

7.5.2 Measurement Results

Performed by: Thierry Jean-Charles

Results are shown below.

Table 7.5.2-1: Power Spectral Density

Frequency (MHz)	PSD (dBm)	Limit (dBm)	Margin (dB)
2405	-3.69	8.0	11.69
2440	-3.76	8.0	11.76
2480	-5.61	8.0	13.61

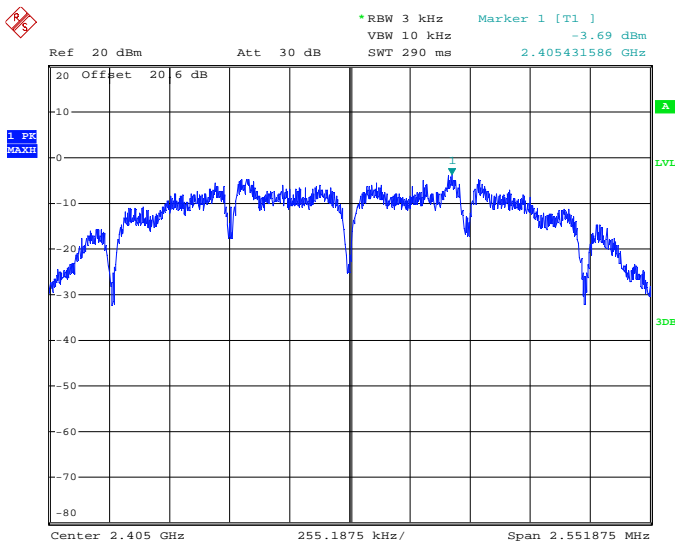

Date: 7.DEC.2018 16:24:49

Figure 7.5.2-1: Power Spectral Density - Low Channel

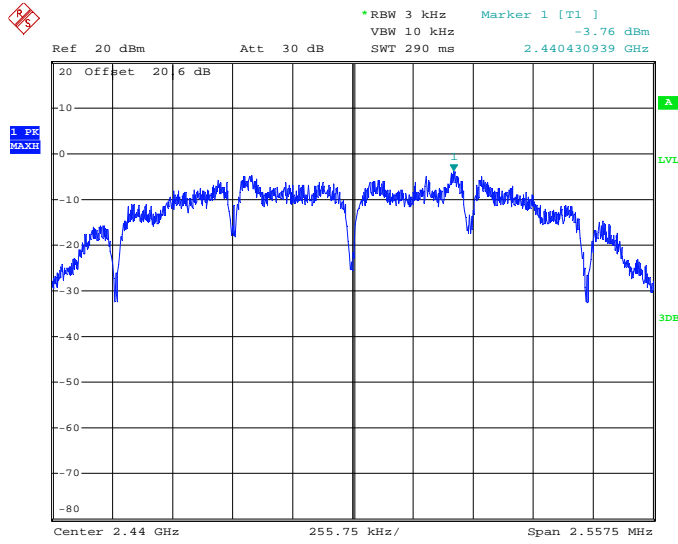

Date: 7.DEC.2018 17:00:50

Figure 7.5.2-2: Power Spectral Density - Middle Channel

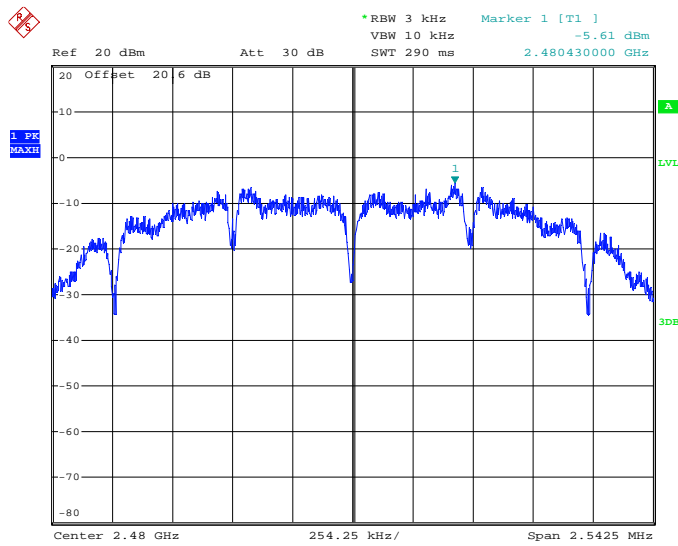

Date: 7.DEC.2018 18:13:35

Figure 7.5.2-3: Power Spectral Density – High Channel

7.6 Power Line Conducted Emissions – FCC: Section 15.207; ISED Canada: RSS-Gen 8.8

7.6.1 Measurement Procedure

ANSI C63.10 section 6.2 was the guiding document for this evaluation. Conducted emissions were performed from 150 kHz to 30 MHz with the spectrum analyzer’s resolution bandwidth set to 9 kHz and the video bandwidth set to 30 kHz. The calculation for the conducted emissions is as follows:

Corrected Reading = Analyzer Reading + LISN Loss + Cable Loss
Margin = Applicable Limit - Corrected Reading

7.6.2 Measurement Results

Performed by: Jean Rene

Table 7.6.2-1: Conducted EMI Results – Line 1

<input checked="" type="checkbox"/> Line 1 <input type="checkbox"/> Line 2 <input type="checkbox"/> Line 3 <input type="checkbox"/> Line 4 <input type="checkbox"/> To Ground <input checked="" type="checkbox"/> Floating <input type="checkbox"/> Telecom Port <input checked="" type="checkbox"/> dBµV <input type="checkbox"/> dBµA Plot Number: 72143516 CUR CE04 L1 Power Supply Description: <u>8.4 VDC</u> DSS Power Supply									
Frequency (MHz)	Uncorrected Reading		Total Correction Factor (dB)	Corrected Level		Limit		Margin (dB)	
	Quasi-Peak	Average		Quasi-Peak	Average	Quasi-Peak	Average	Quasi-Peak	Average
Line 1									
1.11613	39.638	27.02	10.13	49.77	37.15	56.00	46.00	6.2	8.9
1.16726	40.238	26.966	10.13	50.37	37.10	56.00	46.00	5.6	8.9
1.32161	40.216	25.617	10.13	50.35	35.75	56.00	46.00	5.7	10.3
1.41788	42.346	29.358	10.13	52.48	39.49	56.00	46.00	3.5	6.5
1.45963	42.621	27.307	10.13	52.75	37.44	56.00	46.00	3.2	8.6
1.46696	43.123	28.291	10.13	53.25	38.42	56.00	46.00	2.7	7.6
1.49536	43.999	30.598	10.13	54.13	40.73	56.00	46.00	1.9	5.3
1.51909	41.267	26.44	10.13	51.40	36.57	56.00	46.00	4.6	9.4
1.53789	41.789	28.852	10.13	51.92	38.98	56.00	46.00	4.1	7.0
1.55728	41.086	28.373	10.13	51.22	38.50	56.00	46.00	4.8	7.5
1.11613	39.638	27.02	10.13	49.77	37.15	56.00	46.00	6.2	8.9

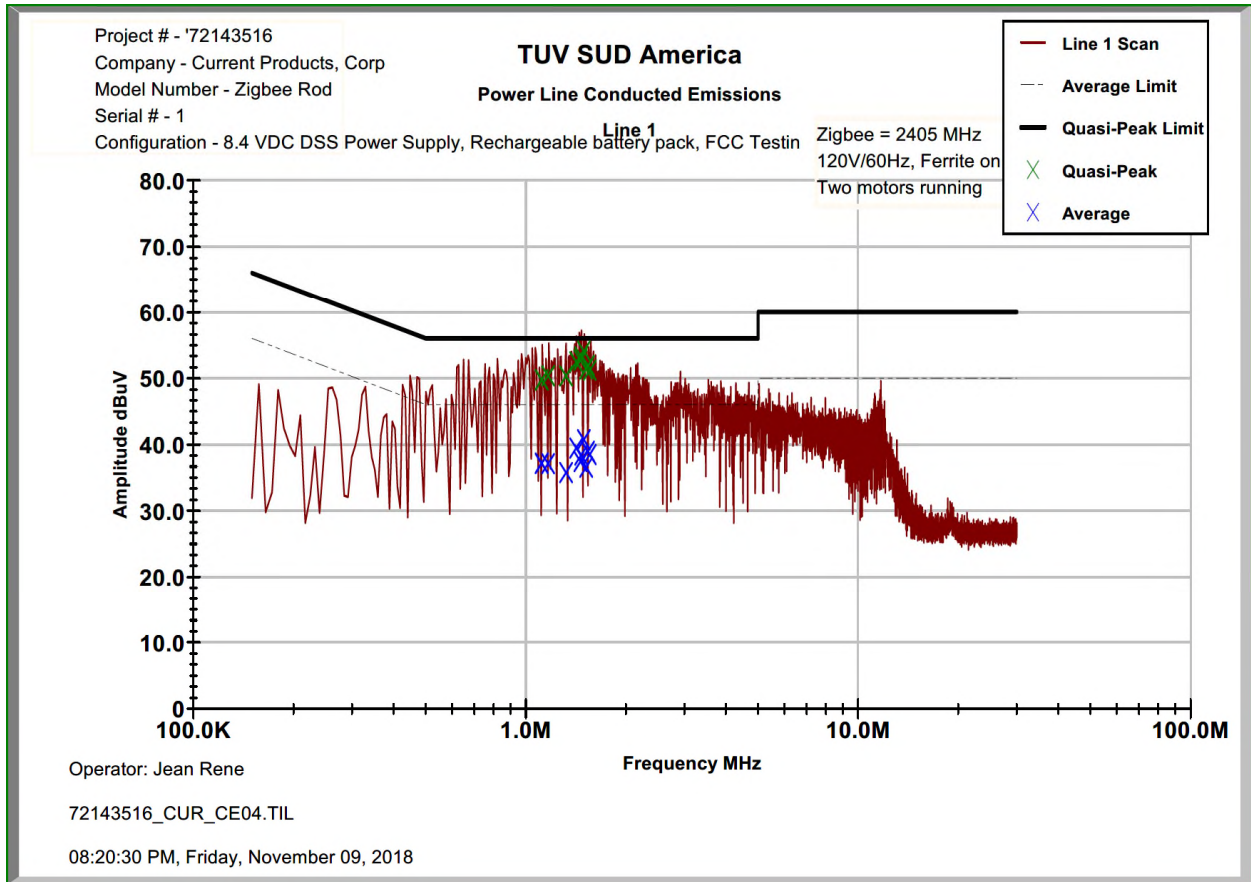

Figure 7.6.2-1: Conducted Emissions Results – Line 1

Table 7.6.2-2: Conducted EMI Results – Line 2

Line 1 Line 2 Line 3 Line 4
 To Ground Floating
 Telecom Port _____
 dBµV dBµA

Plot Number:
 72143516_CUR_CE04_L1
 Power Supply Description: 8.4 VDC
 DSS Power Supply

Frequency (MHz)	Uncorrected Reading		Total Correction Factor (dB)	Corrected Level		Limit		Margin (dB)	
	Quasi-Peak	Average		Quasi-Peak	Average	Quasi-Peak	Average	Quasi-Peak	Average
Line 2									
1.01124	37.51	24.887	10.26	47.77	35.15	56.00	46.00	8.2	10.9
1.12804	36.231	23.22	10.26	46.49	33.48	56.00	46.00	9.5	12.5
1.15657	36.805	24.451	10.26	47.06	34.71	56.00	46.00	8.9	11.3
1.17287	36.27	23.651	10.26	46.53	33.91	56.00	46.00	9.5	12.1
1.20303	36.029	22.846	10.26	46.29	33.11	56.00	46.00	9.7	12.9
1.42359	39.056	25.654	10.26	49.32	35.91	56.00	46.00	6.7	10.1
1.4869	38.623	26.168	10.26	48.88	36.43	56.00	46.00	7.1	9.6
1.51649	37.683	23.089	10.26	47.94	33.35	56.00	46.00	8.1	12.7
1.55078	37.607	24.189	10.26	47.87	34.45	56.00	46.00	8.1	11.6
1.57413	36.659	20.845	10.26	46.92	31.10	56.00	46.00	9.1	14.9

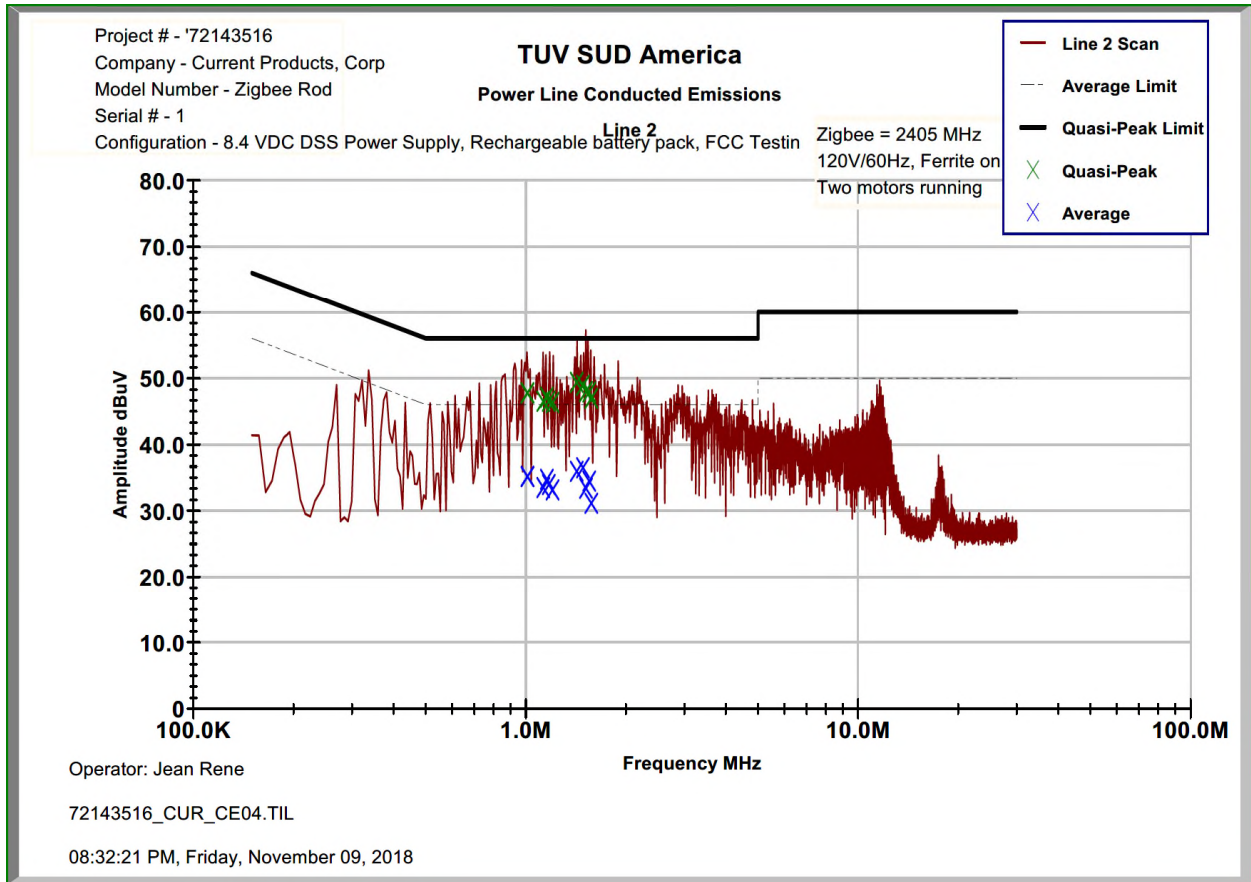

Figure 7.6.2-2: Conducted Emissions Results – Line 2

8 MEASUREMENT UNCERTAINTIES

The expanded laboratory measurement uncertainty figures (U_{Lab}) provided below correspond to an expansion factor (coverage factor) $k = 1.96$ which provide confidence levels of 95%.

Table 8-1: Measurement Uncertainties

Parameter	U_{lab}
Occupied Channel Bandwidth	$\pm 0.009 \%$
RF Conducted Output Power	$\pm 1.15 \text{ dB}$
Power Spectral Density	$\pm 1.15 \text{ dB}$
Antenna Port Conducted Emissions	$\pm 1.15 \text{ dB}$
Radiated Emissions $\leq 1\text{GHz}$	$\pm 5.86 \text{ dB}$
Radiated Emissions $> 1\text{GHz}$	$\pm 4.65 \text{ dB}$
Temperature	$\pm 0.860 \text{ }^\circ\text{C}$
Radio Frequency	$\pm 2.832 \times 10^{-8}$
AC Power Line Conducted Emissions	$\pm 3.72 \text{ dB}$

9 CONCLUSION

In the opinion of TÜV SÜD America, Inc. the models CP19CBZ-01, manufactured by Current Products Corp., meets the requirements of FCC Part 15.247 and Industry Canada's Radio Standards Specification RSS-247 for the tests documented herein.

END REPORT