



Product Specification

Product Name: **M904S**
Bluetooth SiP Module
-BT 4.0 LE

Version: **1.04**

Doc No:

Date: **Nov 25th, 2016**

MtM Technology Corporation
8F, 178 MinQuan East Road Section 3,
Taipei, Taiwan (R.O.C.)
www.mtmtech.com.tw

Document History

Date	Revise Contents	Revise by	Version
Jan. 23, 2014	Initial Version	Brian Juang	XA
Apr. 28, 2015			1.01
Dec. 29, 2015			1.02
Jun. 14, 2016	Add the antenna Design guide, and Modify Power consumption	PJ Chang	1.03
Nov. 25, 2016	1. Revise the reference scheme 2. Add FCC Related information	PJ Chang	1.04

INDEX

1 Description	4
2 Feature	5
3 Block Diagram	6
4 Technical Specification	7
4.1 Recommendable Operation Condition.....	7
4.1 Temperature, humidity.....	7
4.2 Voltage	7
4.3 Wireless Specifications.....	7
4.4 Radio Specifications Bluetooth 4.0 Low Energy.....	8
4.5 External Antenna Design Guide	9
4.5.1 PCB Antenna Design Guide	9
4.5.2 Chip Antenna Design Guide	11
4.6 Power Consumption.....	14
5 Dimensions	17
6 Pin Assignments	19
7 Recommend Footprint	20
8 Reference Design Circuit	21
9 Recommended Reflow Profile	22
10 SiP Module Preparation	23
10.1 Handling.....	23
10.2 SMT Preparation.....	23
11 Package Information	24
11.1 Product Marking	24
11.2 Package Information	25
12 BQB / CE/ FCC Certification	26

1 Description

The SiP module M904S is a small size module with conformal shielding. The module provides full function of Bluetooth 4.0 Low Energy in a tiny module via 48 pins LGA Foot Print. The M904S module provides everything required to create Bluetooth 4.0 Low Energy product with RF, baseband, MCU, qualified Bluetooth v4.0 stack and customer application running on a single IC.

M904S enables ultra-low power connectivity and basic data transfer for applications previously limited by the power consumption, size constraints and complexity of other wireless standards. The low power consumption and excellent radio performance make it the best solution for OEM /ODM customers who require embedded Bluetooth 4.0 Low Energy feature, such as, IP camera, car key, sport and fitness watch, mouse, led light bulb etc.

For the software and driver development, we provide extensive technical document and reference software code for the system integration.

Hardware evaluation kit and development utilities will be released base on listed OS and processors to OEM customers.

2 Feature

- Bluetooth® v4.0 LE radio technology
- -90 dBm sensitivity in Bluetooth® low energy mode
- 250 kbps, 1 Mbps, 2 Mbps supported data rates
- TX Power -20 to +4 dBm in 4 dB steps
- TX Power -30 dBm Whisper mode
- 12 mA peak RX, 10 mA peak TX (0 dBm)
- 256 kB embedded flash program memory
- Supply voltage range 1.8 V to 3.6 V
- SPI Master/Slave
- Low power comparator
- Temperature sensor
- Two-wire Master (I2C compatible)
- UART (CTS/RTS)
- AES HW encryption
- Real Timer Counter (RTC)
- Demo SW Open source on nRF51SDK v8/SoftDevice version 1
- Supports the nRF51SDK v11/SoftDevice v2
- LGA-48 package, 6.5 x 6.5 mm

ORDRING INFORMATION

Part Number	Description
M904S	CLASS 2 Bluetooth single mode Module according BT-4.0. Bluetooth SMART

3 Block Diagram

M904S supports UART command line interface to connect to the host processor. The simplified block diagram is depicted in the Fig. as below..

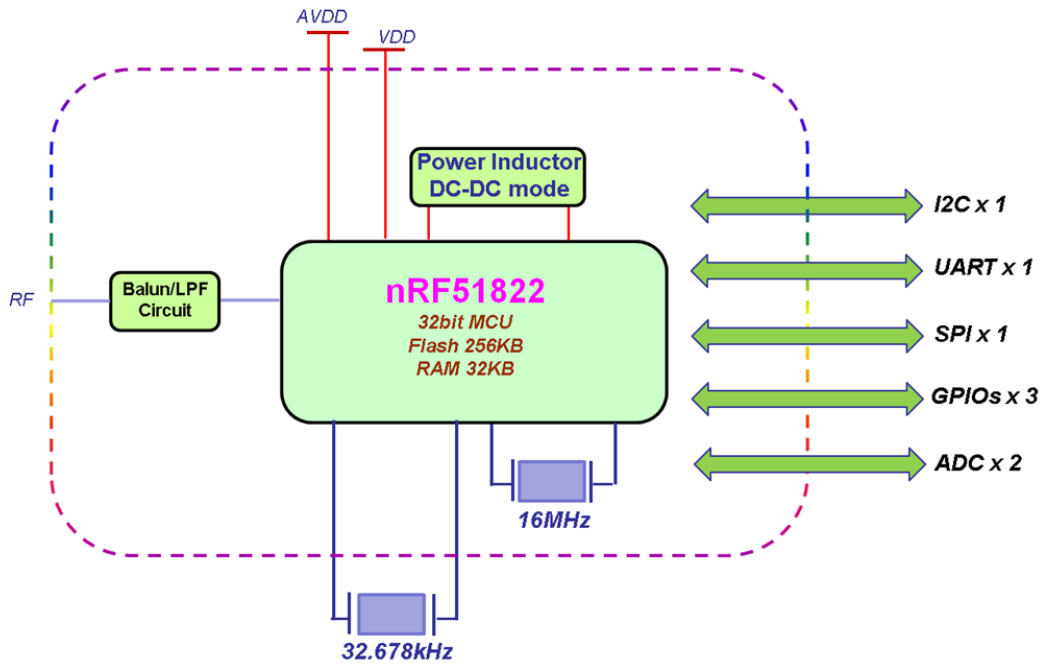

4 Technical Specification

4.1 Recommendable Operation Condition

Temperature, humidity

The M904S module has to withstand the operational requirements as listed in the table below

No	Description	Value	Unit
Ratings Over Operating Free-Air Temperature Range			
1	Supply voltage	All supply pins must have the same voltage	-0.3 to 3.9 V
2	Voltage on any digital pin	TBD	V
3	Operating ambient temperature range	-25 to 75	°C
4	Storage temperature range	-35 to 75	°C
5	Bluetooth RF output	4 ± 1	dBm

4.2 Voltage

Power supply for the M904S module will be provided by the host via the power pins

Operating Condition	Min.	Typ.	Max.
DVDD_3V3	1.8	3.3	3.6
I/O supply voltage (VDD_PADS)	1.2	3.3	3.6

4.3 Wireless Specifications

The M904S module compliance with the following features and standards

Features	Description
Bluetooth Standards	Bluetooth core v4.0 Low Energy
Antenna Port	Support Single Antenna for Bluetooth
Frequency Band	2.402 – 2.480 GHz

4.4 Radio Specifications Bluetooth 4.0 Low Energy

Features	Description
Frequency Band	2.402– 2.480 GHz (2.4 GHz ISM Band)
Number of selectable Sub channels	40 channels
Modulation	GFSK
Supported rates	<2Mbps
Maximum receive level	-10dBm (with PER <30. 8%)

Parameter	Mode and Conditions	Min.	Typ.	Max.	Unit.
RX sensitivity		-	-90	-	dBm
Maximum input			-	-10	dBm
Frequency range		2400	-	2483	MHz
Output power adjustment ranger		-20	-	4	dBm
Output power		-	2	-	dBm
Output power variation		-	4	-	dB

4.5 External Antenna Design Guide

4.5.1 PCB Antenna Design Guide: Peak Gain: -2dBi Typ. / Avg. Gain: -3.5dBi Typ. (XZ-V)

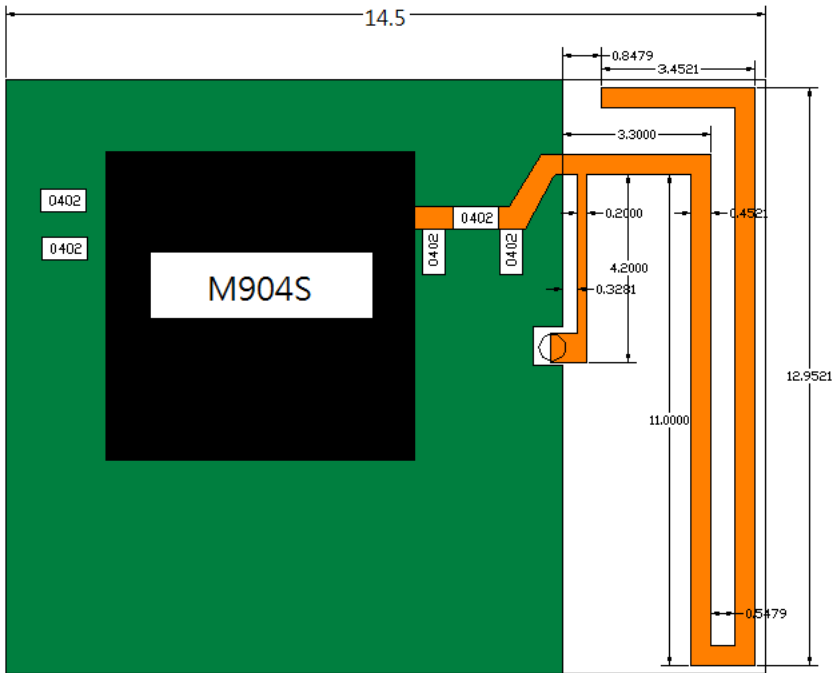

Return Loss

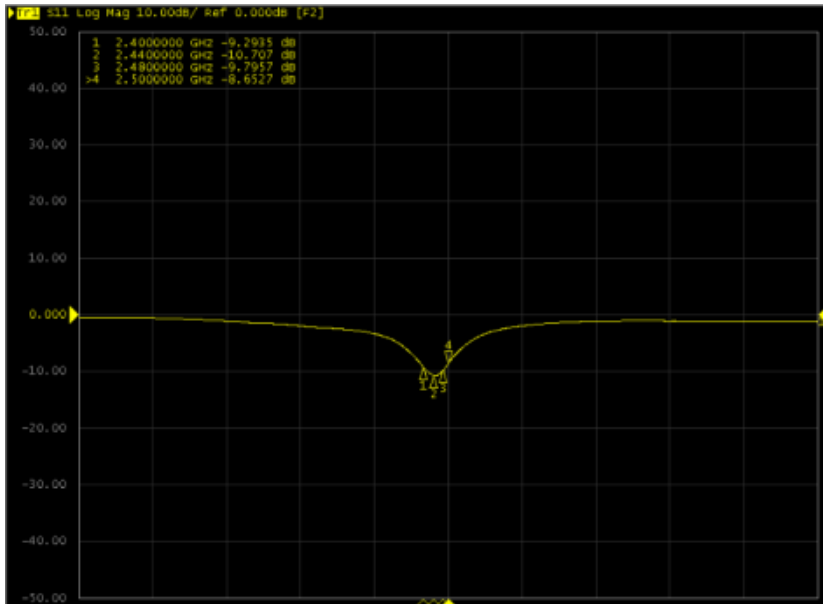

Radiation Patterns

XY-V/XY-H

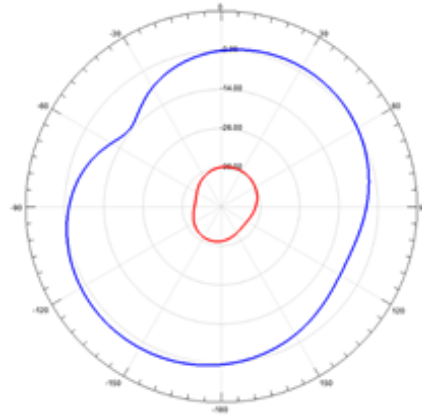
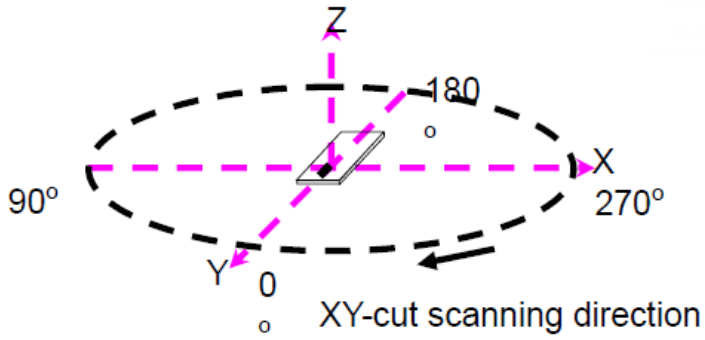

XZ-V/XZ-H

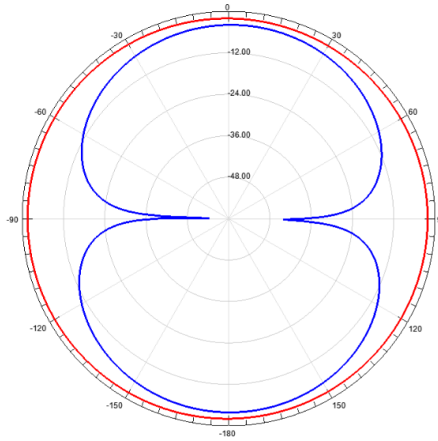
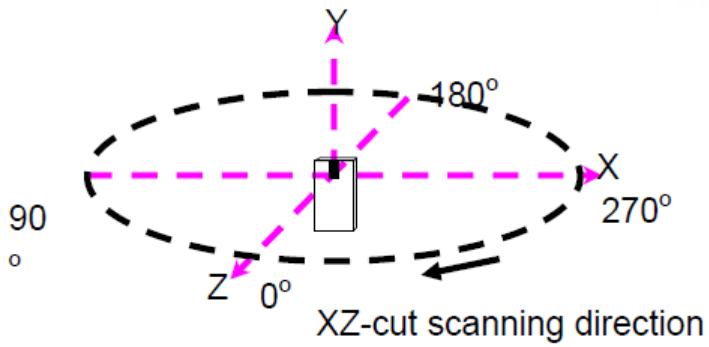

YZ-V/YZ-H

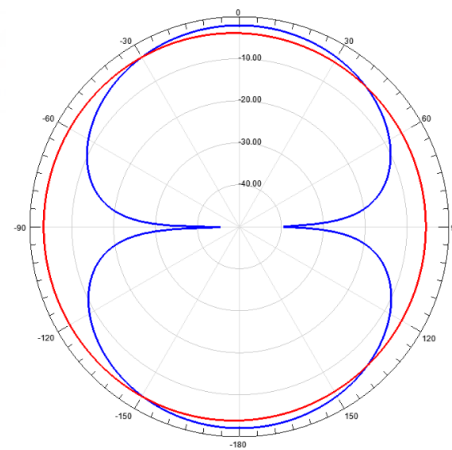
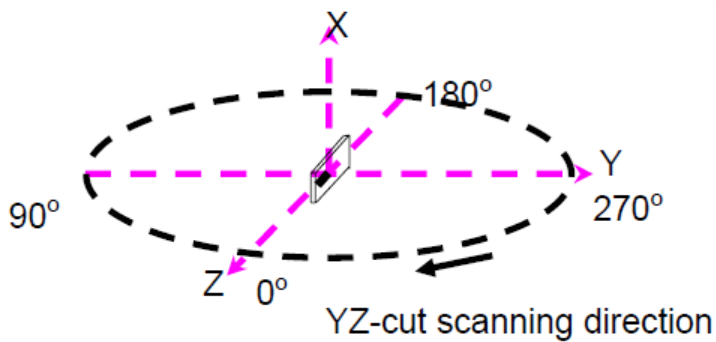

4.5.2 Chip Antenna Design Guide



AT3216 Series Multilayer Chip Antenna

Features

- ❖ Monolithic SMD with small, low-profile and light-weight type.
- ❖ Wide bandwidth

Applications

- ❖ Bluetooth/Wireless LAN/Home RF
- ❖ ISM band 2.4GHz applications



Specifications

Part Number	Frequency Range (MHz)	Peak Gain (XZ-V)	Average Gain (XZ-V)	VSWR	Impedance
AT3216 -B2R7HAA_	2400 ~ 2500	0.5 dBi typ.	-0.5 dBi typ.	2 max.	50 Ω

Dimensions and Recommended PC Board Pattern

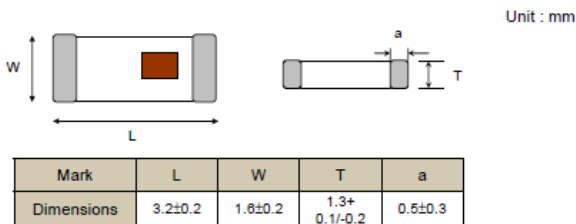

(a) Without Matching Circuits

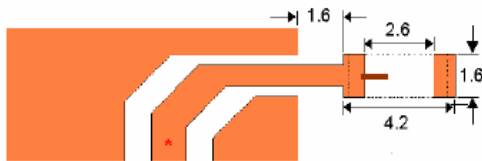

(b) With Matching Circuits

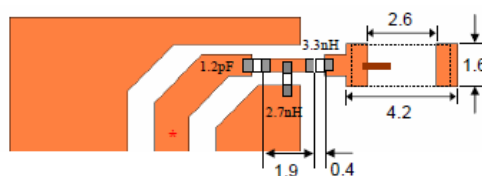

© MtM Technology Corporation. All rights reserved

Return Loss\With Matching Circuits

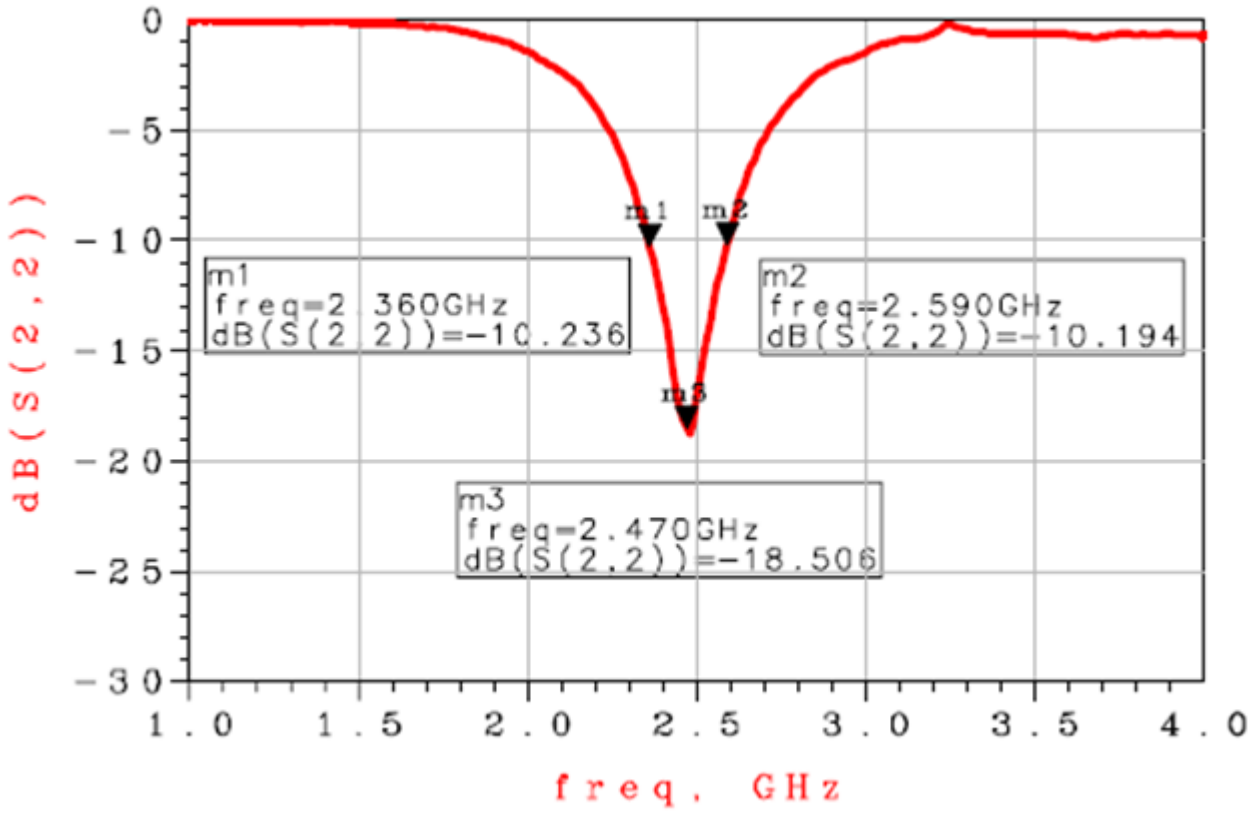

Radiation Patterns

XY-V/XY-H

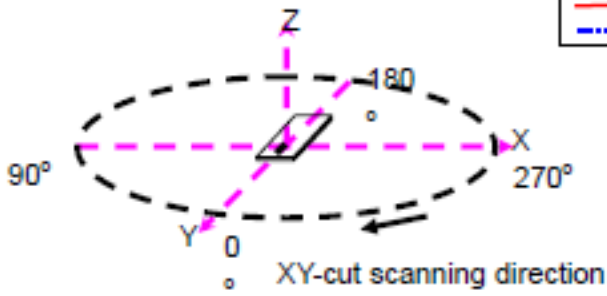

XY cut @2.45GHz
 — Vertical
 - - - Horizontal

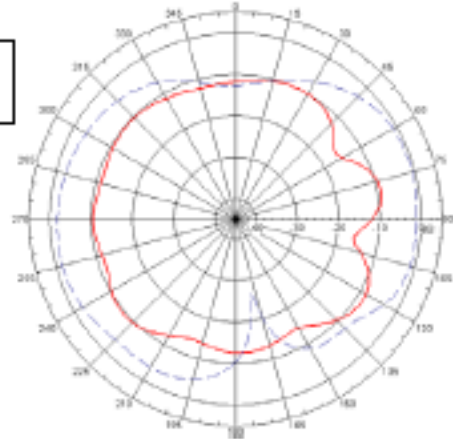

XZ-V/XZ-H

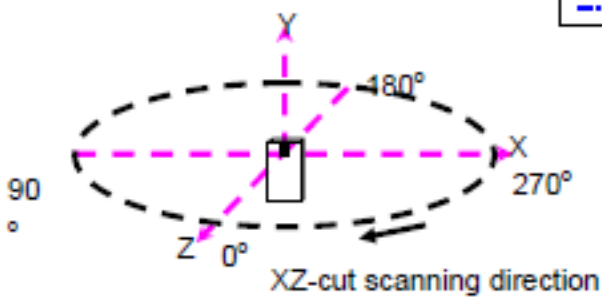

XZ cut @2.45GHz
 — Vertical
 - - - Horizontal

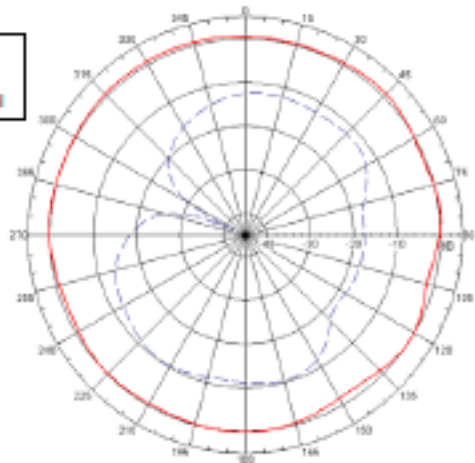

YZ-V/YZ-H

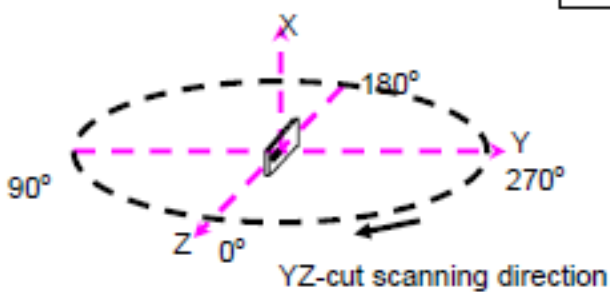

YZ cut @2.45GHz
 — Vertical
 - - - Horizontal

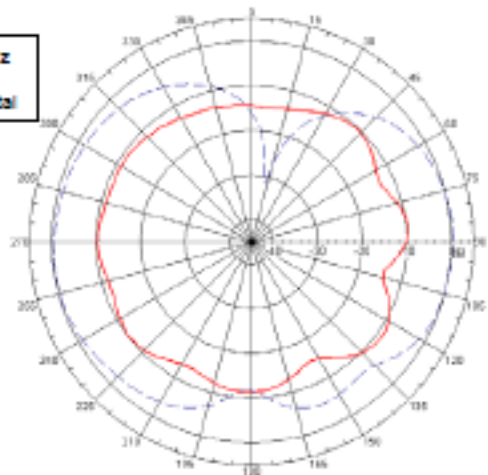

4.5.2 Dipole Antenna Design Guide: Return Loss

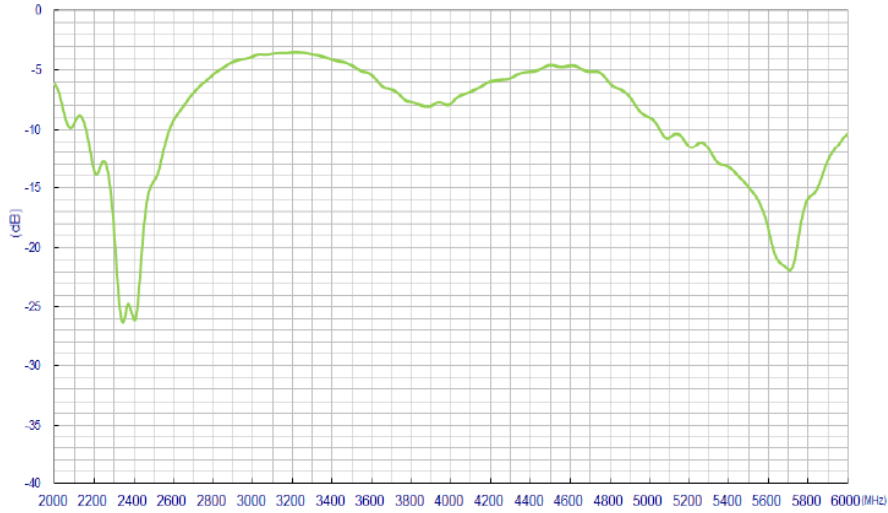

Radiation Patterns

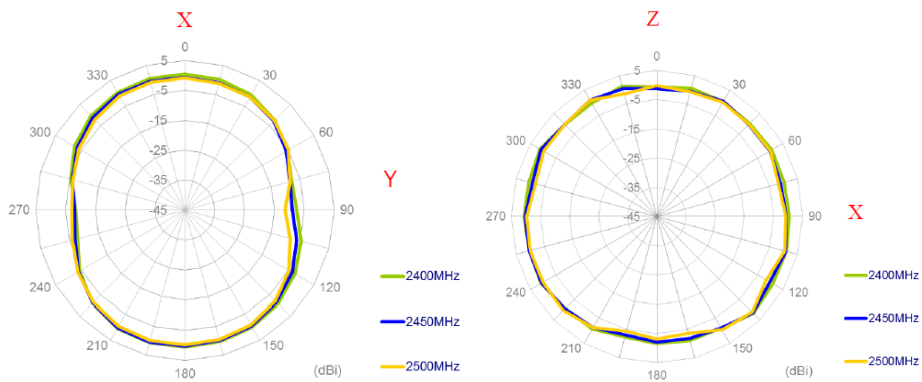

xy-plane

xz-plane

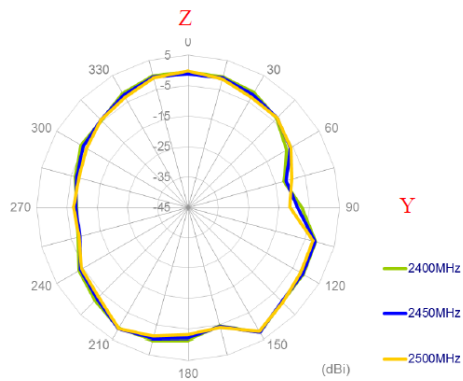

yz-plane

4.5.4 PIFA Antenna Design Guide: Return Loss

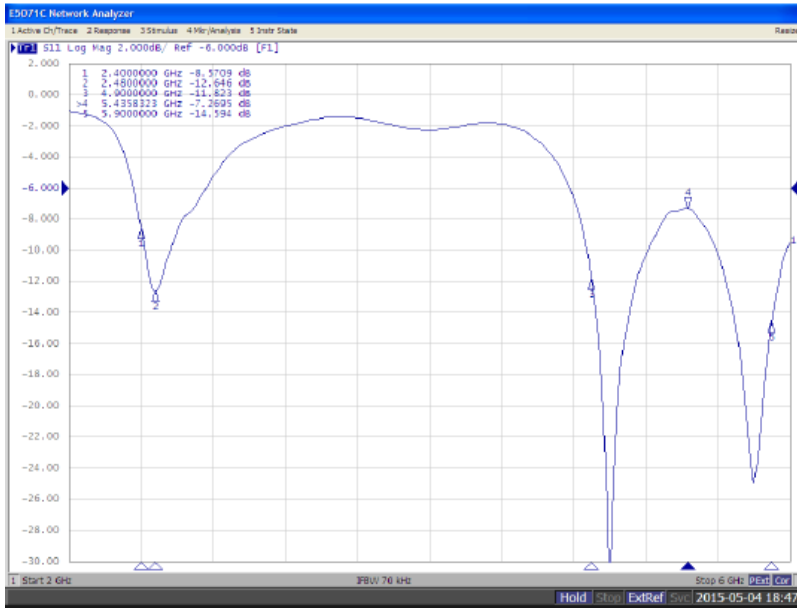

Radiation Patterns

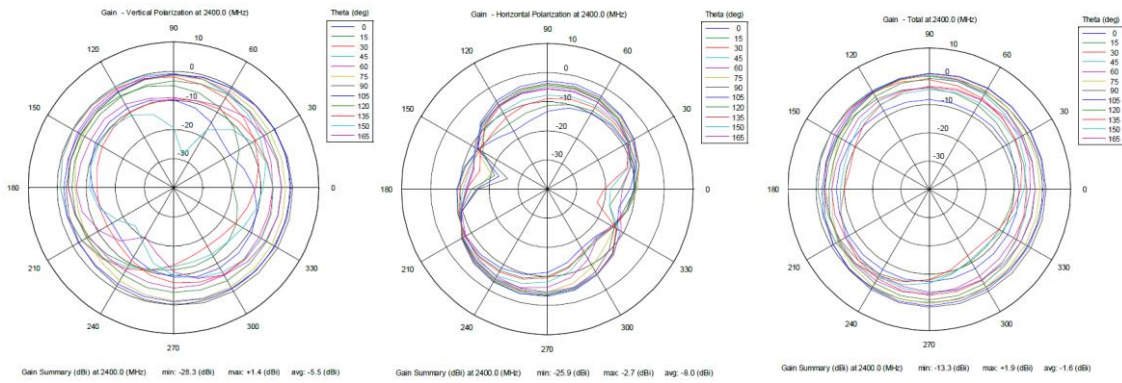

Vertical, Horizontal and Total Gain Patterns at 2400MHz

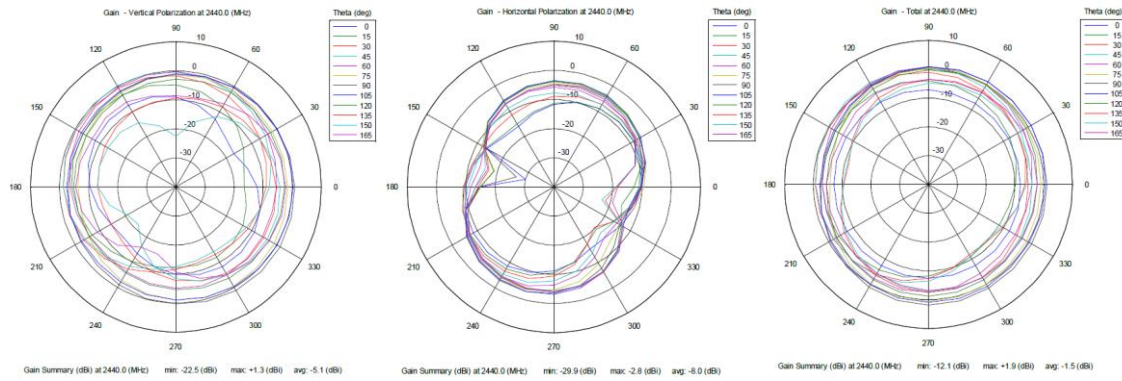

Vertical, Horizontal and Total Gain Patterns at 2440MHz

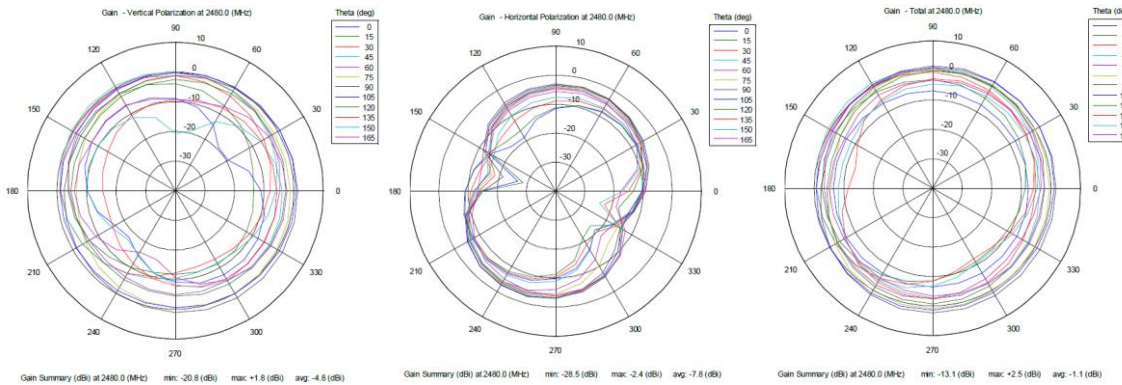

Vertical, Horizontal and Total Gain Patterns at 2480MHz

4.6 Power Consumption

Item	Condition	Typ.
Tx mode	3.3V	9.76mA
Rx mode	3.3V	12.15mA
System ON Constant Latency	Sleep Mode	0.41uA

Power Management

Symbol	Description	Note	Min.	Typ.	Max.	Units	Test level
I_{OFF}	Current in SYSTEM OFF, no RAM retention.			0.6 ¹		μ A	2
$I_{OFF, RET, 8k}$	Additional current in SYSTEM OFF per retained RAM block (8 kB)			0.6 ¹		μ A	2
I_{OFF2ON}	OFF to CPU execute transition current.			400		μ A	1
t_{OFF2ON}	OFF to CPU execute.			9.6	10.6	μ s	1
$I_{ON, 16k}$	SYSTEM-ON base current with 16 kB RAM enabled.			2.6 ¹		μ A	2
$I_{ON, 32k}$	SYSTEM-ON base current with 32 kB RAM enabled.			3.8 ¹		μ A	2
t_{1V2}	Startup time for 1V2 regulator.			2.3		μ s	1
$I_{1V2XO16}$	Current drawn by 1V2 regulator and 16 MHz XOOSC when both are on at the same time.	See Table 33 on page 48.		810 ²		μ A	1

Symbol	Description	Note	Min.	Typ.	Max.	Units	Test level
t_{1V7}	Startup time for 1V7 regulator			2	3.6	μ s	1
I_{1V7}	Current drawn by 1V7 regulator			105		μ A	2
F_{DCDC}	DC/DC converter current conversion factor.			0.65 ⁴	1.2 ⁴		1

F_{DCDC} will vary depending on VDD and internal radio current consumption (I_{DD}). Please refer to the *nRF51 Series Reference Manual*, v3.0 or later, for a method to calculate $I_{DD, DCDC}$. See [Figure 11](#) on page 50 for a DC/DC conversion factor chart.

Radio Current Consumption

Symbol	Description	Note	Min.	Typ.	Max.	Units	Test level
$I_{TX,+4dBm}$	TX only run current at $P_{OUT} = +4$ dBm.	1		16		mA	4
$I_{TX,0dBm}$	TX only run current at $P_{OUT} = 0$ dBm.	1		10.5		mA	4
$I_{TX,-4dBm}$	TX only run current at $P_{OUT} = -4$ dBm.	1		8		mA	2
$I_{TX,-8dBm}$	TX only run current at $P_{OUT} = -8$ dBm.	1		7		mA	2
$I_{TX,-12dBm}$	TX only run current at $P_{OUT} = -12$ dBm.	1		6.5		mA	2
$I_{TX,-16dBm}$	TX only run current at $P_{OUT} = -16$ dBm.	1		6		mA	2
$I_{TX,-20dBm}$	TX only run current at $P_{OUT} = -20$ dBm.	1		5.5		mA	2
$I_{TX,-30dBm}$	TX only run current at $P_{OUT} = -30$ dBm.	1		5.5		mA	2
$I_{START,TX}$	TX startup current.	2		7		mA	1
$I_{RX,250}$	RX only run current at 250 kbps.			12.6		mA	1
$I_{RX,1M}$	RX only run current at 1 Mbps.			13		mA	4
$I_{RX,2M}$	RX only run current at 2 Mbps.			13.4		mA	1
$I_{START,RX}$	RX startup current.	3		8.7		mA	1

1. Valid for data rates 250 kbps, 1 Mbps, and 2 Mbps.
2. Average current consumption (at 0 dBm TX output power) for TX startup (130 μ s), and when changing mode from RX to TX (130 μ s).
3. Average current consumption for RX startup (130 μ s), and when changing mode from TX to RX (130 μ s).

Transmitter Specifications

Symbol	Description	Min.	Typ.	Max.	Units	Test level
P_{RF}	Maximum output power.		4		dBm	4
P_{RFC}	RF power control range.	20	24		dB	2
PRFCR	RF power accuracy.			± 4	dB	1
P_{WHISP}	RF power whisper mode.		-30		dBm	2
P_{BW2}	20 dB bandwidth for modulated carrier (2 Mbps).		1800	2000	kHz	2
P_{BW1}	20 dB bandwidth for modulated carrier (1 Mbps).		950	1100	kHz	2
P_{BW250}	20 dB bandwidth for modulated carrier (250 kbps).		700	800	kHz	2
$P_{RF1.2}$	1 st Adjacent Channel Transmit Power. ± 2 MHz (2 Mbps).			-20	dBc	2
$P_{RF2.2}$	2 nd Adjacent Channel Transmit Power. ± 4 MHz (2 Mbps).			-45	dBc	2
$P_{RF1.1}$	1 st Adjacent Channel Transmit Power. ± 1 MHz (1 Mbps).			-20	dBc	2
$P_{RF2.1}$	2 nd Adjacent Channel Transmit Power. ± 2 MHz (1 Mbps).			-40	dBc	2
$P_{RF1.250}$	1 st Adjacent Channel Transmit Power. ± 1 MHz (250 kbps).			-25	dBc	2
$P_{RF2.250}$	2 nd Adjacent Channel Transmit Power. ± 2 MHz (250 kbps).			-40	dBc	2
$t_{TX,30}$	Maximum consecutive transmission time, $f_{TOL} < \pm 30$ ppm.			16	ms	1
$t_{TX,60}$	Maximum consecutive transmission time, $f_{TOL} < \pm 60$ ppm.			4	ms	1

5 Dimensions

The size and thickness of the M904 module 6.5mm (W) x 6.5mm (L) x 1.3mm (H):

Top-View:

Side-View:

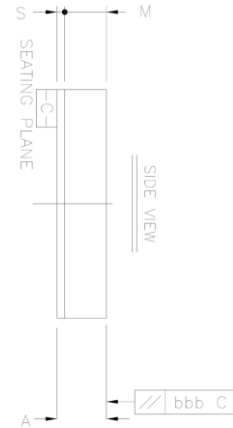
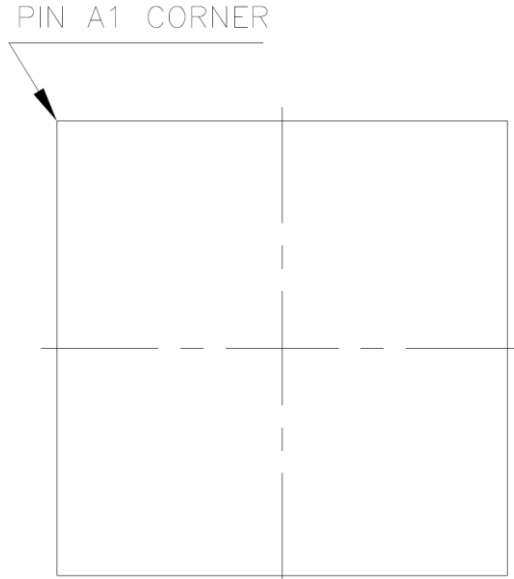

Bottom-View:

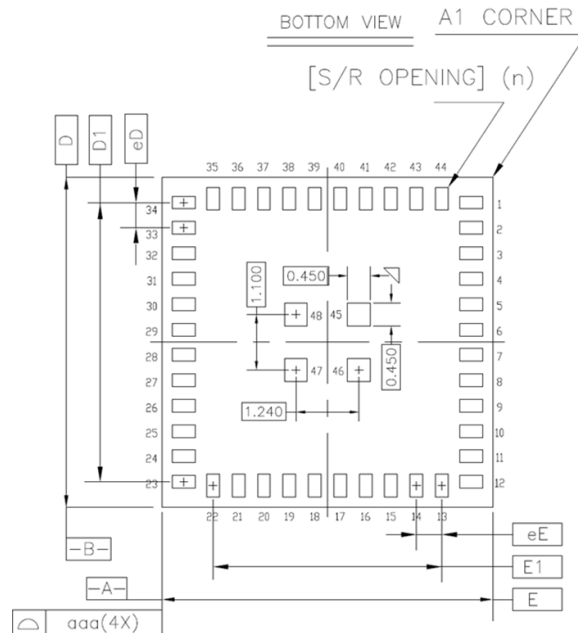

Dimensions

		Symbol	Common Dimensions
Package :			PIM
Body Size:	X	E	6.500
	Y	D	6.500
Ball Pitch :	X	eE	0.500
	Y	eD	0.500
Total Thickness :		A	1.300±0.100
Mold Thickness :		M	1.100 Ref.
Substrate Thickness :		S	0.200 Ref.
S/R Opening :			0.450*0.450/0.250*0.450
Stand Off :		A1	--- ~ ---
Ball Width :		b	--- ~ ---
Package Edge Tolerance :		aaa	0.100
Mold Flatness :		bbb	0.100
Coplanarity:		ddd	---
Ball Offset (Package) :		eee	---
Ball Offset (Ball) :		fff	---
Ball Count :		n	48
Edge Ball Center to Center :	X	E1	4.500
	Y	D1	5.500

6 Pin Assignments

6.1 Pin Description

The foot print dimension and pin definition is defined as below

Pin number	Pin name	Pin function	Description
1 to 9	VSS	Power	Ground (0V)
10	RF	BLE RF (antenna connection)	BLE RF (antenna connection)
11	ANT	Antenna	Antenna feed
12	VSS	Power	Ground (0V)
13	DEC2	Power	Power supply decoupling
14	SWDCLK	Digital input	Hardware debug and flash programming I/O
15	SWDIO/ nRESET	Digital I/O	System reset (active low). Also hardware debug and flash programming I/O.
16	P0_16	Digital I/O	General purpose I/O pin.
17	P0_15	Digital I/O	General purpose I/O pin.
18	P0_14	Digital I/O	General purpose I/O pin.
19	P0_13	Digital I/O	General purpose I/O pin.
20	P0_09	Digital I/O	General purpose I/O pin.
21	P0_08	Digital I/O	General purpose I/O pin.
22	P0_06	Digital I/O	General purpose I/O pin.
23	AIN6	Analog input	ADC/LPCOMP input
24	AIN5	Analog input	ADC/LPCOMP input
25	AIN4	Analog input	ADC/LPCOMP input
26	AIN2	Analog input	ADC/LPCOMP input
27	AIN3	Analog input	ADC/LPCOMP input
28	AREFO	Analog input	ADC/LPCOMP reference input
29	PWR	Power	Power supply
30	VSS	Power	Ground (0V)
31	AIN1_XL1	Analog input Analog output	ADC/LPCOMP input Connection for 32.768 kHz crystal.
32	AIN0_XL2	Analog input Analog input	ADC/LPCOMP input 1 Connection for 32.768 kHz crystal or external 32.768 kHz clock reference.
33	VSS	Power	Ground (0V)
34	ANT_TEST	Antenna test	Antenna open/short test
35	VSS	Power	Ground (0V)
36	AVDD	Power	Analog power supply
37 to 48	VSS	Power	Ground (0V)

7 Recommend Footprint

Suggest on PCB: SMD (1:1)

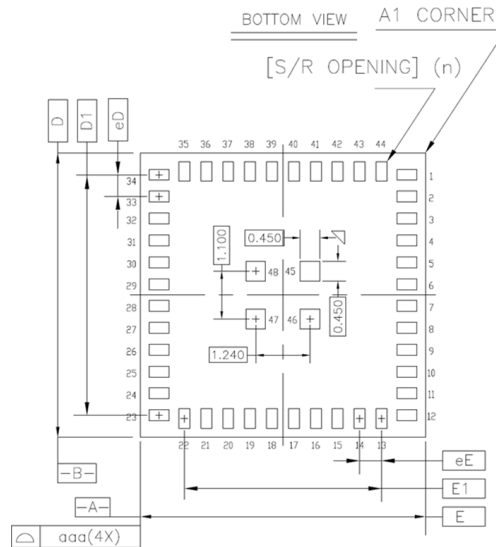

		Symbol	Common Dimensions
Package :			PIM
Body Size:	X	E	6.500
	Y	D	6.500
Ball Pitch :	X	eE	0.500
	Y	eD	0.500
Total Thickness :		A	1.300±0.100
Mold Thickness :		M	1.100 Ref.
Substrate Thickness :		S	0.200 Ref.
S/R Opening :			0.450*0.450/0.250*0.450
Stand Off :		A1	--- ~ ---
Ball Width :		b	--- ~ ---
Package Edge Tolerance :		aaa	0.100
Mold Flatness :		bbb	0.100
Coplanarity:		ddd	---
Ball Offset (Package) :		eee	---
Ball Offset (Ball) :		fff	---
Ball Count :		n	48
Edge Ball Center to Center :	X	E1	4.500
	Y	D1	5.500

8 Reference Design Circuit

8.1 Reference Schematic

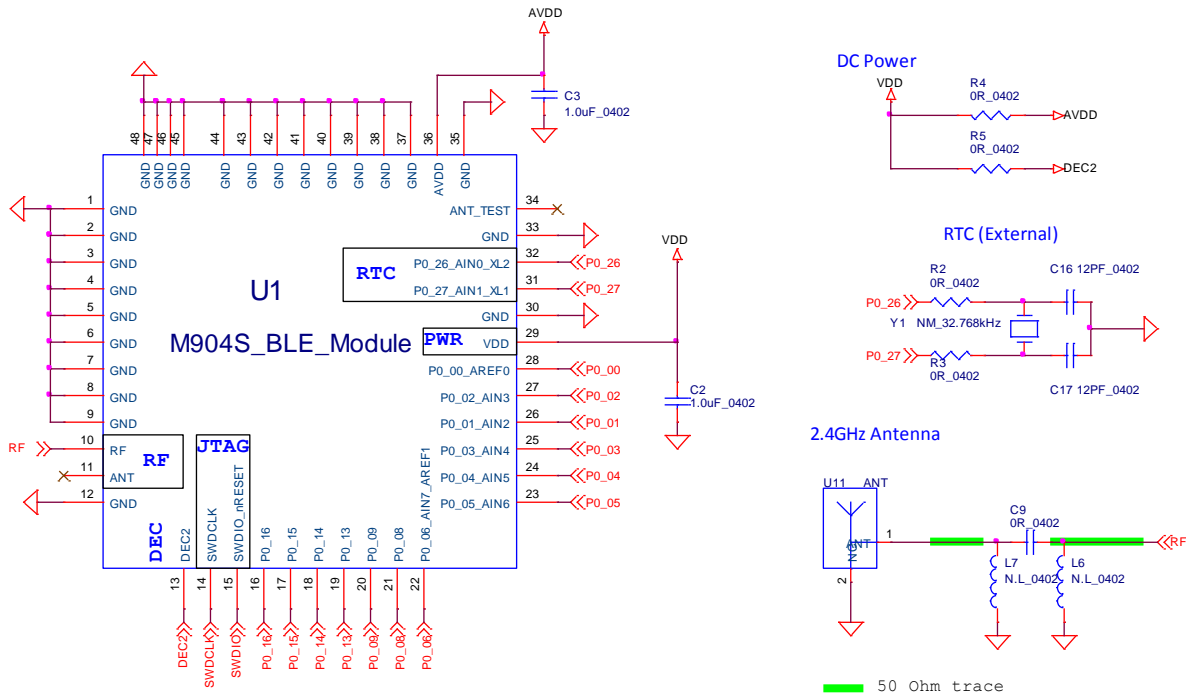

8.2 Layout Guide

The following points are observed for antenna.

Reference	Description
1	The RF traces bends must be gradual with an approximate maximum bend of 45 degrees
2	RF traces must have via on ground plane beside the RF trace on both sides
3	RF traces must have constant impedance (microstrip transmission line)
4	RF trace ground layer must be the solid ground layer immediately below RF trace.
5	There must be no trace and ground under antenna section

RF Section Layout

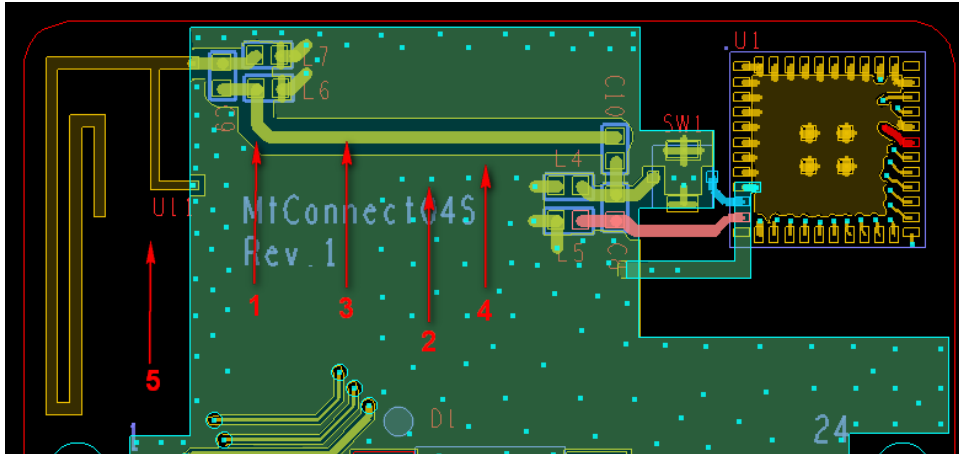

RF Section Layout

Coplanar Waveguide With Groundplane No Groundplane Main Menu [F8]

Calculate Z0 [F4]

Z0 = **50.0** Ω

Elect Length = 13.550 λ

Elect Length = 4877.9 degrees

1.0 Wavelength = 73.803 mm

Vp = 0.603 fraction of c

ε eff = 2.75

Shape factor = 0.512

Dielectric: εr = 4.3

FR-5

Frequency: 2.45 GHz

Length Units: mm

CPW impedance Calculation

9 Recommended Reflow Profile

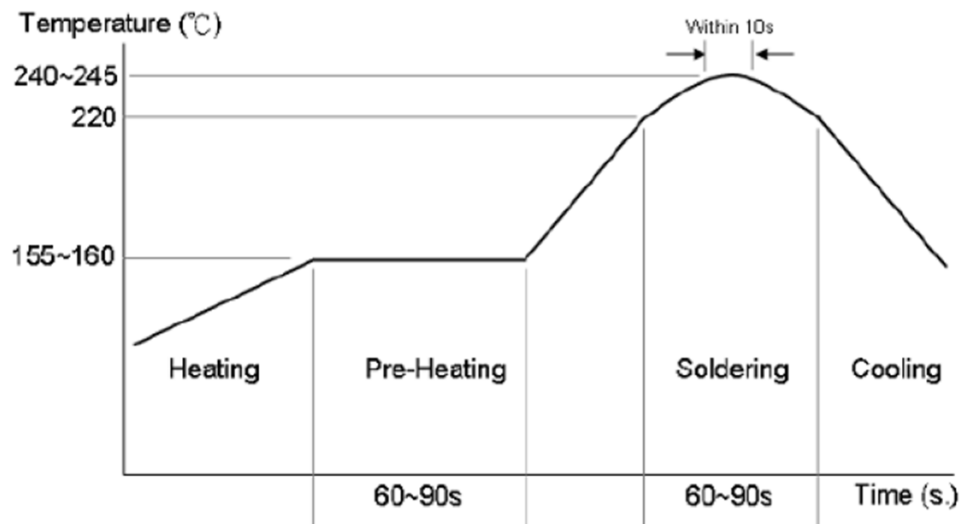

Profile Condition

- Suitable for Lead-Free solder
- Between 155~160°C: 60~90 sec.
- Above 220°C: 60~90 sec.
- Peak Temperature: 240~245 (<10 sec.)

10 SiP Module Preparations

10.1 Handling

Handling the module must wear the anti-static wrist strap to avoid ESD damage. After each module is aligned and tested, it should be transport and storage with anti-static tray and packing. This protective package must be remained in suitable environment until the module is assembled and soldered onto the main board.

10.2 SMT Preparation

1. Calculated shelf life in sealed bag: 6 months at $<40^{\circ}\text{C}$ and $<90\%$ relative humidity (RH).
2. Peak package body temperature: 250°C .
3. After bag was opened, devices that will be subjected to reflow solder or other high temperature process must.
 - A. Mounted within: 72 hours of factory conditions $<30^{\circ}\text{C}/60\%$ RH.
 - B. Stored at $\leq 10\%$ RH with N2 flow box.
4. Devices require baking, before mounting, if:
 - A. Package bag does not keep in vacuumed while first time open.
 - B. Humidity Indicator Card is $>10\%$ when read at $23\pm 5^{\circ}\text{C}$.
 - C. Expose at 3A condition over 8 hours or Expose at 3B condition over 24 hours.
5. If baking is required, devices may be baked for 12 hours at $125\pm 5^{\circ}\text{C}$.

11 Package Information

11.1 Product Marking

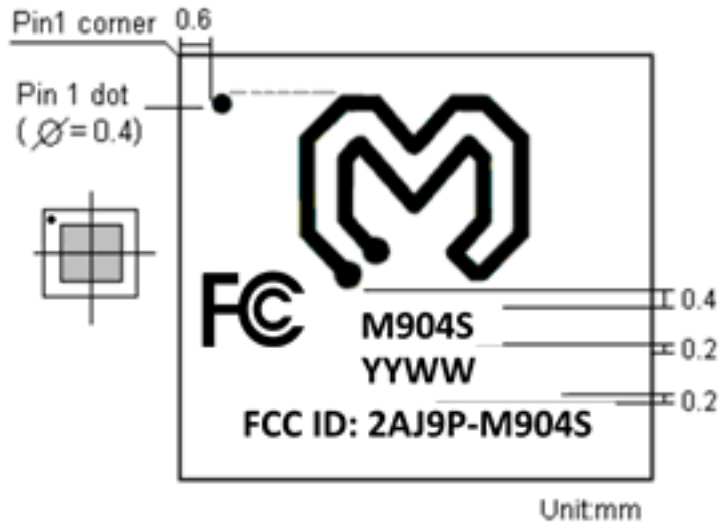

- Line 1: M904S
- Line 2: YYWW
- Line 3: FCC ID: 2AJ9P-M904S

11.2 Package Information

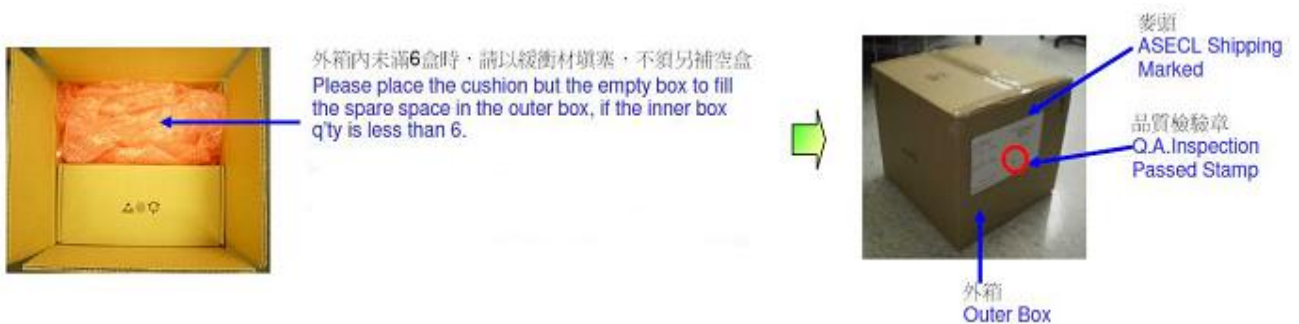
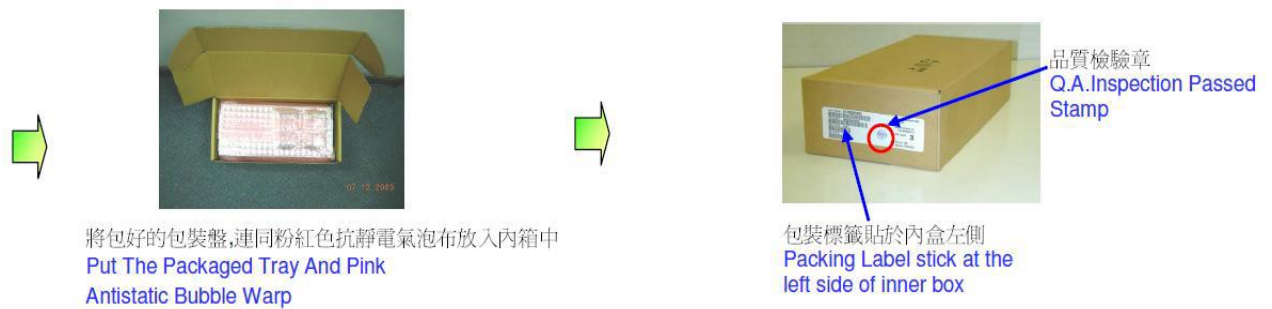
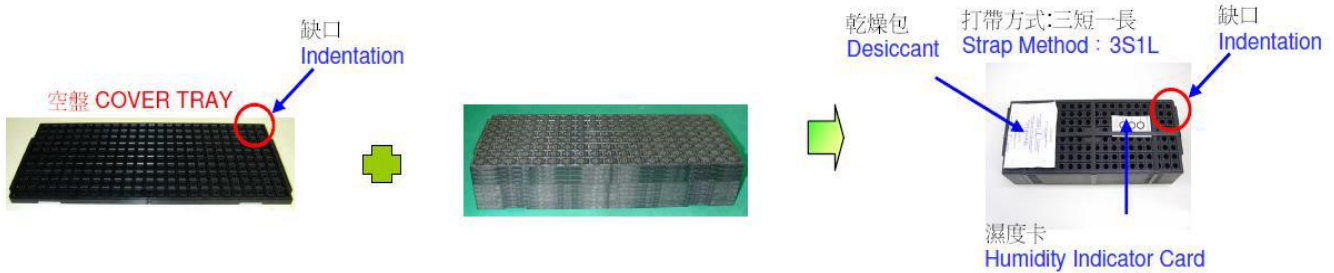

12 BQB/CE/FCC Certification

12.1 FCC (USA)

Federal Communication Commission Interference Statement

This equipment has been tested and found to comply with the limits for a Class B digital device, pursuant to Part 15 of the FCC Rules. These limits are designed to provide reasonable protection against harmful interference in a residential installation. This equipment generates, uses and can radiate radio frequency energy and, if not installed and used in accordance with the instructions, may cause harmful interference to radio communications. However, there is no guarantee that interference will not occur in a particular installation. If this equipment does cause harmful interference to radio or television reception, which can be determined by turning the equipment off and on, the user is encouraged to try to correct the interference by one or more of the following measures:

- Reorient or relocate the receiving antenna.
- Increase the separation between the equipment and receiver.
- Connect the equipment into an outlet on a circuit different from that to which the receiver is connected.
- Consult the dealer or an experienced radio/TV technician for help.

FCC Caution: Any changes or modifications not expressly approved by the party responsible for compliance could void the user's authority to operate this equipment.

This device complies with Part 15 of the FCC Rules. Operation is subject to the following two conditions: (1) This device may not cause harmful interference, and (2) this device must accept any interference received, including interference that may cause undesired operation.

This device and its antenna(s) must not be co-located or operating in conjunction with any other antenna or transmitter.

IMPORTANT NOTE:

FCC Radiation Exposure Statement:

This equipment complies with FCC radiation exposure limits set forth for an uncontrolled environment. This equipment should be installed and operated with minimum distance 20cm between the radiator & your body.

IMPORTANT NOTE:

This module is intended for OEM integrator.

The OEM integrator is still responsible for the FCC compliance requirement of the end product, which integrates this module.

Appropriate measurements (e.g. 15 B compliance) and if applicable additional equipment authorizations (e.g. Verification , Doc) of the host device to be addressed by the integrator/manufacturer.

IMPORTANT NOTE:

This module is intended for OEM integrator. The OEM integrator is still responsible for the FCC compliance requirement of the end product, which integrates this module.

The device has been evaluated to meet general RF exposure requirement, The device can be used in portable exposure condition without restriction.

Any changes or modifications not expressly approved by the manufacturer could void the user's authority to operate this equipment.

USERS MANUAL OF THE END PRODUCT:

In the users manual of the end product, the end user has to be informed to keep at least 20cm separation with the antenna while this end product is installed and operated. The end user has to be informed that the FCC radio-frequency exposure guidelines for an uncontrolled environment can be satisfied. The end user has to also be informed that any changes or modifications not expressly approved by the manufacturer could void the user's authority to operate this equipment. If the size of the end product is smaller than the palm of the hand, then additional FCC part 15.19 statement is required to be available in the users manual: This device complies with Part 15 of FCC rules. Operation is subject to the following two conditions: (1) this device may not cause harmful interference and (2) this device must accept any interference received, including interference that may cause undesired operation.

LABEL OF THE END PRODUCT:

The final end product must be labeled in a visible area with the following " Contains TX FCC ID: **2AJ9P-M904S**". If the size of the end product is larger than the palm of the hand, then the following FCC part 15.19 statement has to also be available on the label: This device complies with Part 15 of FCC rules. Operation is subject to the following two conditions: (1) this device may not cause harmful interference and (2) this device must accept any interference received, including interference that may cause undesired operation.

Professional installation

Section 15.204(b) states that an approved "transmission system" must always be marketed as a complete system including the antenna.