

RF TEST REPORT



Report No.: 16070642-FCC-R

Supersede Report No.: N/A

Applicant	DongGuan TuoXiang Electronics Technology Co.,Ltd	
Product Name	Bluetooth Headphone	
Model No.	HBS-730	
Serial No.	HBS-730TF HBS-770TF HV-800 HBS-730S HBS-770, HBS-760S HBS-530 HBS-580 HBS-600 HBS-650 HBS-660 HBS-860 HBS-880 HBS-930 HBS-950 HBS-960 HBS-980	
Test Standard	FCC Part 15.247: 2015, ANSI C63.10: 2013	
Test Date	June 13 to 23, 2016	
Issue Date	June 24, 2016	
Test Result	<input checked="" type="checkbox"/> Pass <input type="checkbox"/> Fail	
Equipment complied with the specification	<input checked="" type="checkbox"/>	
Equipment did not comply with the specification	<input type="checkbox"/>	
Loren Luo Test Engineer	David Huang Checked By	
This test report may be reproduced in full only Test result presented in this test report is applicable to the tested sample only		

Issued by:

SIEMIC (SHENZHEN-CHINA) LABORATORIES

Zone A, Floor 1, Building 2 Wan Ye Long Technology Park

South Side of Zhoushi Road, Bao' an District, Shenzhen, Guangdong China 518108

Phone: +86 0755 2601 4629801 Email: China@siemic.com.cn

Laboratories Introduction

SIEMIC, headquartered in the heart of Silicon Valley, with superior facilities in US and Asia, is one of the leading independent testing and certification facilities providing customers with one-stop shop services for Compliance Testing and Global Certifications.



In addition to testing and certification, SIEMIC provides initial design reviews and compliance management throughout a project. Our extensive experience with China, Asia Pacific, North America, European, and International compliance requirements, assures the fastest, most cost effective way to attain regulatory compliance for the global markets.

Accreditations for Conformity Assessment

Country/Region	Scope
USA	EMC, RF/Wireless, SAR, Telecom
Canada	EMC, RF/Wireless, SAR, Telecom
Taiwan	EMC, RF, Telecom, SAR, Safety
Hong Kong	RF/Wireless, SAR, Telecom
Australia	EMC, RF, Telecom, SAR, Safety
Korea	EMI, EMS, RF, SAR, Telecom, Safety
Japan	EMI, RF/Wireless, SAR, Telecom
Singapore	EMC, RF, SAR, Telecom
Europe	EMC, RF, SAR, Telecom, Safety

Test Report	16070642-FCC-R
Page	3 of 57

This page has been left blank intentionally.

CONTENTS

1. REPORT REVISION HISTORY	5
2. CUSTOMER INFORMATION	5
3. TEST SITE INFORMATION.....	5
4. EQUIPMENT UNDER TEST (EUT) INFORMATION.....	6
5. TEST SUMMARY	7
6. MEASUREMENTS, EXAMINATION AND DERIVED RESULTS	8
6.1 ANTENNA REQUIREMENT.....	8
6.2 CHANNEL SEPARATION	9
6.3 20DB BANDWIDTH.....	13
6.4 PEAK OUTPUT POWER.....	17
6.5 NUMBER OF HOPPING CHANNEL.....	21
6.6 TIME OF OCCUPANCY (DWELL TIME)	23
6.7 BAND EDGE.....	27
6.8 AC POWER LINE CONDUCTED EMISSIONS.....	35
6.9 RADIATED SPURIOUS EMISSIONS.....	41
ANNEX A. TEST INSTRUMENT.....	47
ANNEX B. EUT AND TEST SETUP PHOTOGRAPHS.....	48
ANNEX C. TEST SETUP AND SUPPORTING EQUIPMENT.....	52
ANNEX D. USER MANUAL / BLOCK DIAGRAM / SCHEMATICS / PARTLIST.....	56
ANNEX E. DECLARATION OF SIMILARITY.....	57

1. Report Revision History

Report No.	Report Version	Description	Issue Date
16070642-FCC-R	NONE	Original	June 24, 2016

2. Customer information

Applicant Name	DongGuan TuoXiang Electronics Technology Co.,Ltd
Applicant Add	Fifth Floor, Building 1E,HongDa Industrial Zone , JianShe Road , ShiMa village , Tangxia Town, Dongguan City, Guangdong Province, China
Manufacturer	DongGuan TuoXiang Electronics Technology Co.,Ltd
Manufacturer Add	Fifth Floor, Building 1E,HongDa Industrial Zone , JianShe Road , ShiMa village , Tangxia Town, Dongguan City, Guangdong Province, China

3. Test site information

Lab performing tests	SIEMIC (Shenzhen-China) LABORATORIES
Lab Address	Zone A, Floor 1, Building 2 Wan Ye Long Technology Park South Side of Zhoushi Road, Bao' an District, Shenzhen, Guangdong China 518108
FCC Test Site No.	718246
IC Test Site No.	4842E-1
Test Software	Radiated Emission Program-To Shenzhen v2.0

4. Equipment under Test (EUT) Information

Description of EUT:	Bluetooth Headphone
Main Model:	HBS-730
Serial Model:	HBS-730TF HBS-770TF HV-800 HBS-730S HBS-770, HBS-760S HBS-530 HBS-580 HBS-600 HBS-650 HBS-660 HBS-860 HBS-880 HBS-930 HBS-950 HBS-960 HBS-980
Date EUT received:	June 12, 2016
Test Date(s):	June 13 to 23, 2016
Equipment Category :	DSS
Antenna Gain:	1.2dBi
Antenna Type:	PCB antenna
Type of Modulation:	GFSK, π /4DQPSK,8DPSK
RF Operating Frequency (ies):	2402-2480 MHz
Max. Output Power:	-1.117dBm
Number of Channels:	79CH
Port:	USB Port
Input Power:	Battery: 3.7V,120mAh USB Port: 5V
Trade Name :	N/A
FCC ID:	2AIN2HBS-730

5. Test Summary

The product was tested in accordance with the following specifications.

All testing has been performed according to below product classification:

FCC Rules	Description of Test	Result
§15.203	Antenna Requirement	Compliance
§15.247(a)(1)	Channel Separation	Compliance
§15.247(a)(1)	20 dB Bandwidth	Compliance
§15.247(b)(1)	Peak Output Power	Compliance
§15.247(a)(1)(iii)	Number of Hopping Channel	Compliance
§15.247(a)(1)(iii)	Time of Occupancy (Dwell Time)	Compliance
§15.247(d)	Band Edge	Compliance
§15.207(a)	AC Line Conducted Emissions	Compliance
§15.205, §15.209, §15.247(d)	Radiated Emissions	Compliance

Measurement Uncertainty

Emissions		
Test Item	Description	Uncertainty
Band Edge and Radiated Spurious Emissions	Confidence level of approximately 95% (in the case where distributions are normal), with a coverage factor of 2 (for EUTs < 0.5m X 0.5m X 0.5m)	+5.6dB/-4.5dB
-	-	-

6. Measurements, Examination And Derived Results

6.1 Antenna Requirement

Applicable Standard

According to § 15.203, an intentional radiator shall be designed to ensure that no antenna other than that furnished by the responsible party shall be used with the device. The use of a permanently attached antenna or of an antenna that uses a unique coupling to the intentional radiator shall be considered sufficient to comply with the provisions of this section. The manufacturer may design the unit so that a broken antenna can be replaced by the user, but the user of a standard antenna jack or electrical connector is prohibited. The structure and application of the EUT were analyzed to determine compliance with section §15.203 of the rules. §15.203 state that the subject device must meet the following criteria:

- a. Antenna must be permanently attached to the unit.
- b. Antenna must use a unique type of connector to attach to the EUT.

Unit must be professionally installed, and installer shall be responsible for verifying that the correct antenna is employed with the unit.

And according to FCC 47 CFR section 15.247 (b), if the transmitting antennas of directional gain greater than 6dBi are used, the power shall be reduced by the amount in dB that the directional gain of the antenna exceeds 6 dBi.

Antenna Connector Construction

The EUT has 1 antenna:

A permanently attached PCB antenna for Bluetooth, the gain is 1.2dBi for Bluetooth.

The antenna meets up with the ANTENNA REQUIREMENT.

Result: Compliance.

6.2 Channel Separation

Temperature	22°C
Relative Humidity	59%
Atmospheric Pressure	1017mbar
Test date :	June 17, 2016
Tested By :	Loren Luo

Requirement(s):

Spec	Item	Requirement	Applicable
§ 15.247(a)(1)	a)	Channel Separation < 20dB BW and 20dB BW < 25KHz ; Channel Separation Limit=25KHz Chanel Separation < 20dB BW and 20dB BW > 25kHz ; Channel Separation Limit=2/3 20dB BW	<input checked="" type="checkbox"/>
Test Setup			
Test Procedure	<p>The test follows FCC Public Notice DA 00-705 Measurement Guidelines. Use the following spectrum analyzer settings:</p> <ul style="list-style-type: none"> - The EUT must have its hopping function enabled - Span = wide enough to capture the peaks of two adjacent channels - Resolution (or IF) Bandwidth (RBW) ≥ 1% of the span - Video (or Average) Bandwidth (VBW) ≥ RBW - Sweep = auto - Detector function = peak - Trace = max hold - Allow the trace to stabilize. Use the marker-delta function to determine the separation between the peaks of the adjacent channels. The limit is specified in one of the subparagraphs of this Section. Submit this plot. 		

Remark	
Result	<input checked="" type="checkbox"/> Pass <input type="checkbox"/> Fail

Test Data Yes N/A

Test Plot Yes (See below) N/A

Channel Separation measurement result

Type/ Modulation	CH	CH Freq (MHz)	CH Separation (MHz)	Limit (MHz)	Result
CH Separation GFSK	Low Channel	2402	1.005	0.691	Pass
	Adjacency Channel	2403			
	Mid Channel	2440	1.005	0.692	Pass
	Adjacency Channel	2441			
	High Channel	2480	1.005	0.695	Pass
	Adjacency Channel	2479			
CH Separation $\pi/4$ DQPSK	Low Channel	2402	1.005	0.845	Pass
	Adjacency Channel	2403			
	Mid Channel	2440	1.005	0.837	Pass
	Adjacency Channel	2441			
	High Channel	2480	1.005	0.836	Pass
	Adjacency Channel	2479			
	Adjacency Channel	2479			
CH Separation 8DPSK	Low Channel	2402	1.005	0.842	Pass
	Adjacency Channel	2403			
	Mid Channel	2440	1.005	0.839	Pass
	Adjacency Channel	2441			
	High Channel	2480	1.005	0.840	Pass
	Adjacency Channel	2479			

Test Plots

Channel Separation measurement result

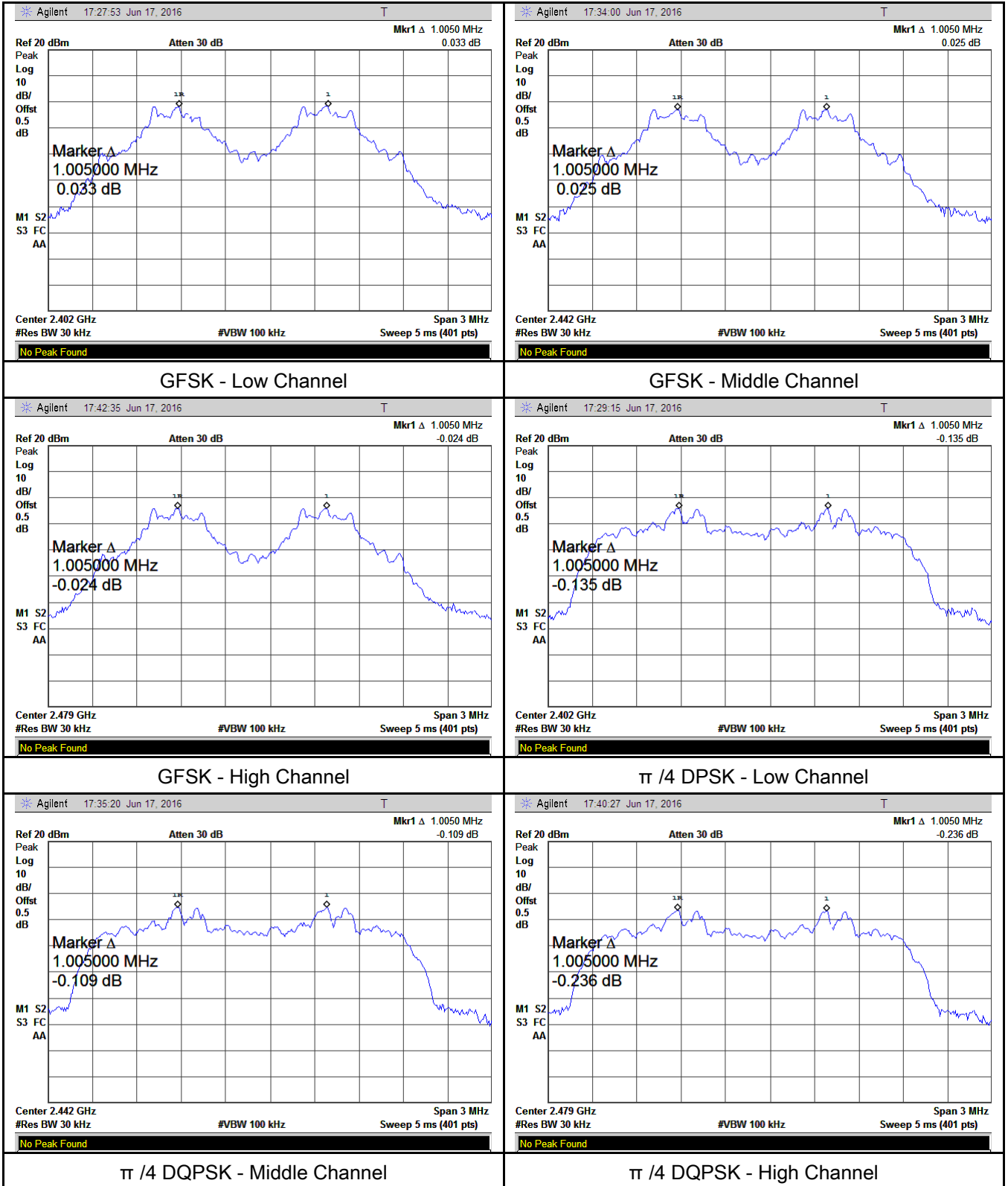

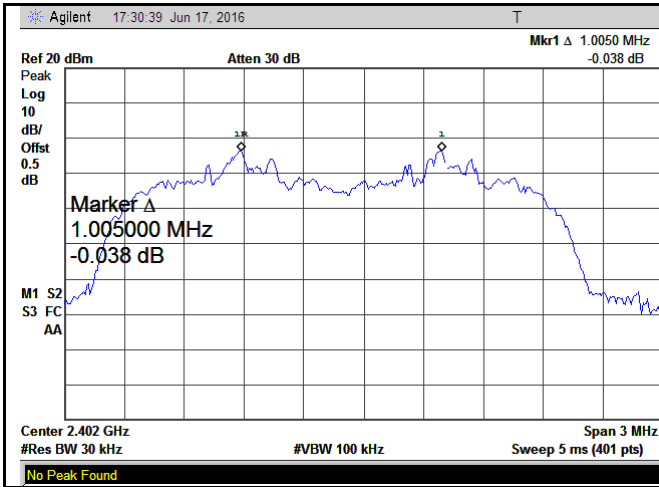

8DPSK - Low Channel

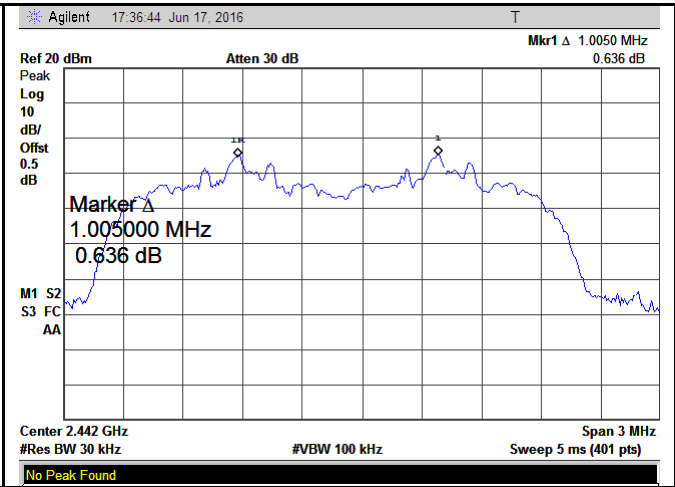

8DPSK - Middle Channel

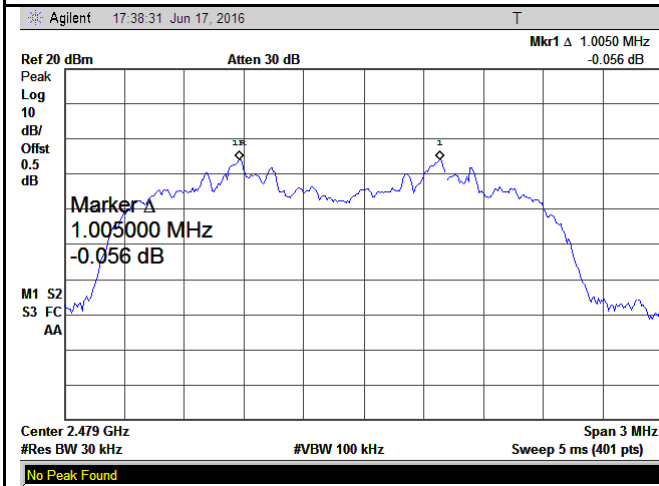

8DPSK - High Channel

6.3 20dB Bandwidth

Temperature	22°C
Relative Humidity	59%
Atmospheric Pressure	1017mbar
Test date :	June 17, 2016
Tested By :	Loren Luo

Requirement(s):

Spec	Item	Requirement	Applicable
§15.247(a) (1)	a)	Frequency hopping systems shall have hopping channel carrier frequencies separated by a minimum of 25 kHz or the 20 dB bandwidth of the hopping channel, whichever is greater.	<input checked="" type="checkbox"/>

Test Setup	
------------	--

Test Procedure	<p>The test follows FCC Public Notice DA 00-705 Measurement Guidelines. <u>Use the following spectrum analyzer settings:</u></p> <ul style="list-style-type: none"> - Span = approximately 2 to 3 times the 20 dB bandwidth, centered on a hopping channel - RBW ≥ 1% of the 20 dB bandwidth - VBW ≥ RBW - Sweep = auto - Detector function = peak - Trace = max hold. - The EUT should be transmitting at its maximum data rate. Allow the trace to stabilize. Use the marker-to-peak function to set the marker to the peak of the emission. Use the marker-delta function to measure 20 dB down one side of the emission. Reset the marker-delta function, and move the marker to the other side of the emission, until it is (as close as possible to) even with the reference
----------------	--

	marker level. The marker-delta reading at this point is the 20 dB bandwidth of the emission. If this value varies with different modes of operation (e.g., data rate, modulation format, etc.), repeat this test for each variation. The limit is specified in one of the subparagraphs of this Section. Submit this plot(s).
Remark	
Result	<input checked="" type="checkbox"/> Pass <input type="checkbox"/> Fail

Test Data Yes N/A

Test Plot Yes (See below) N/A

Measurement result

Modulation	CH	CH Freq (MHz)	20dB Bandwidth (MHz)	99% Occupied Bandwidth (MHz)
GFSK	Low	2402	1.036	0.9062
	Mid	2441	1.038	0.8796
	High	2480	1.027	0.8905
π /4 DQPSK	Low	2402	1.267	1.1581
	Mid	2441	1.256	1.1464
	High	2480	1.254	1.1526
8DPSK	Low	2402	1.263	1.1557
	Mid	2441	1.258	1.1552
	High	2480	1.260	1.1548

Test Plots

20dB Bandwidth measurement result

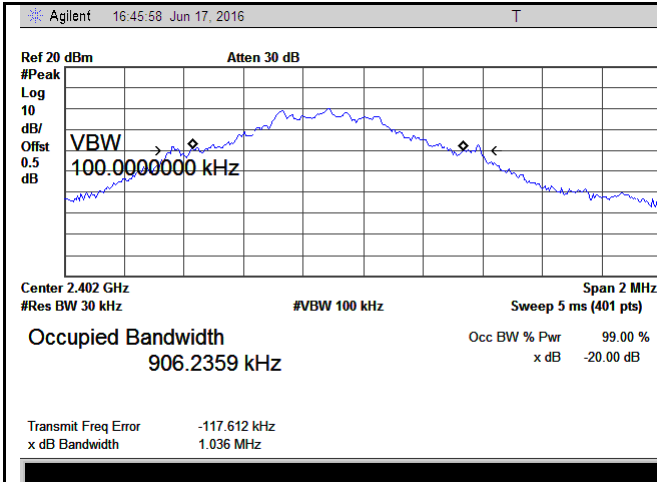

GFSK - Low Channel

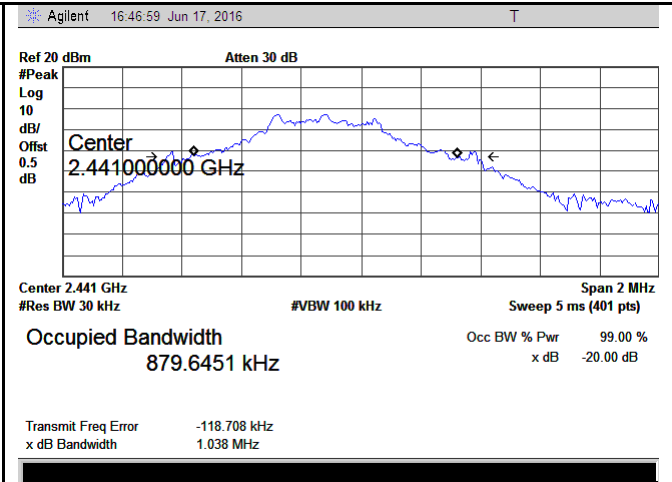

GFSK - Middle Channel

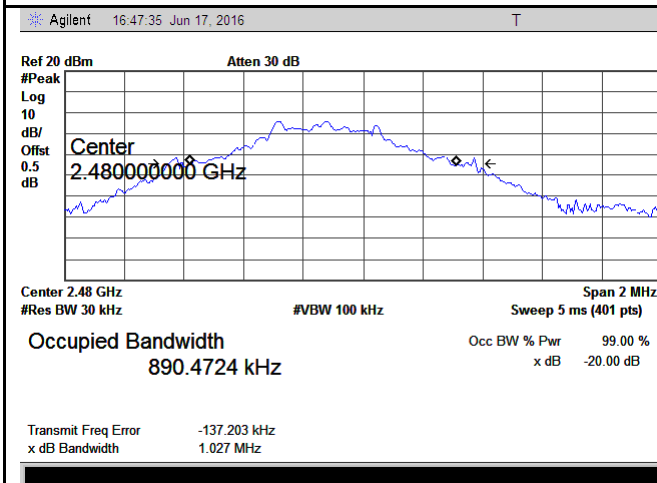

GFSK - High Channel

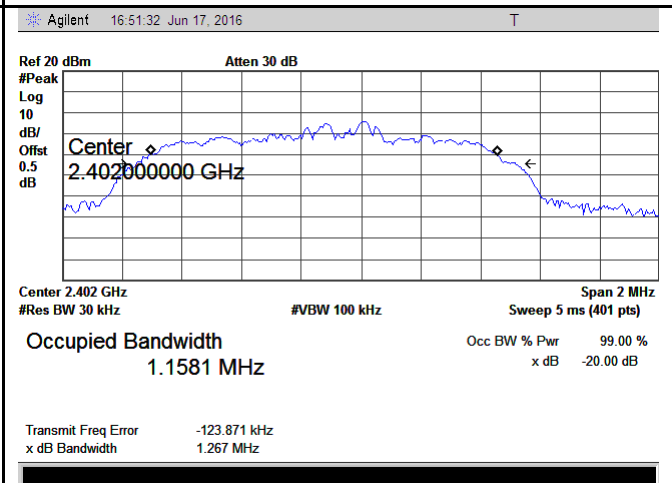

$\pi/4$ DPSK - Low Channel

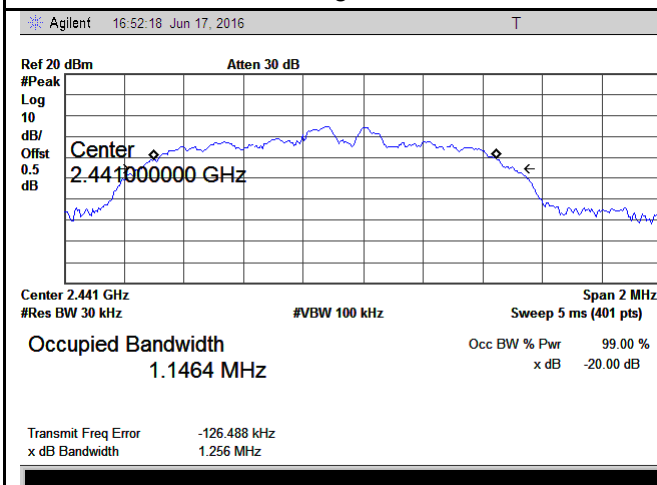

$\pi/4$ DQPSK - Middle Channel

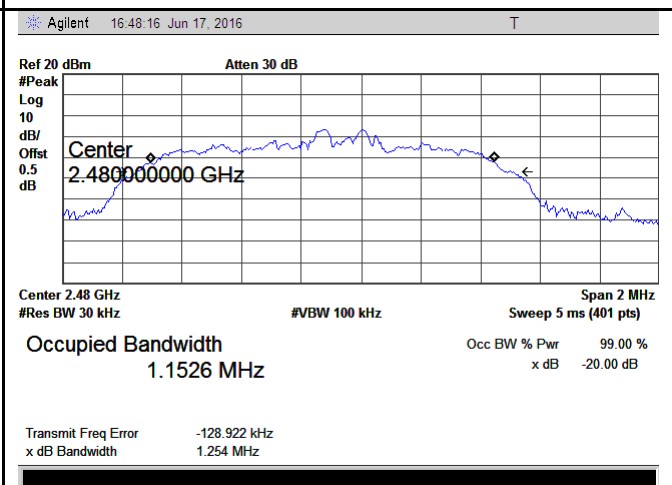

$\pi/4$ DQPSK - High Channel

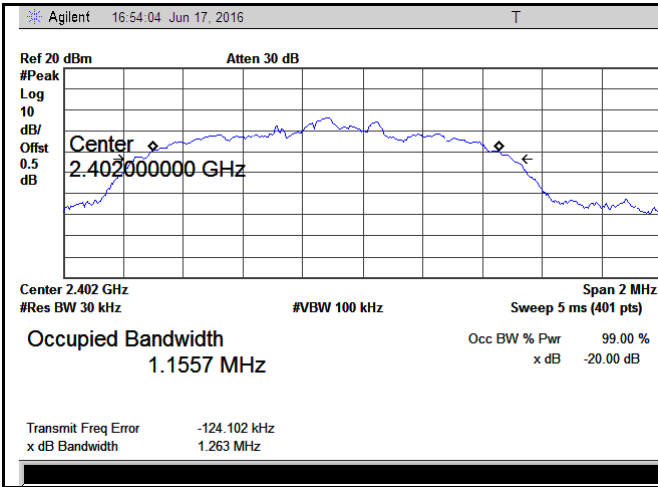

8DPSK - Low Channel

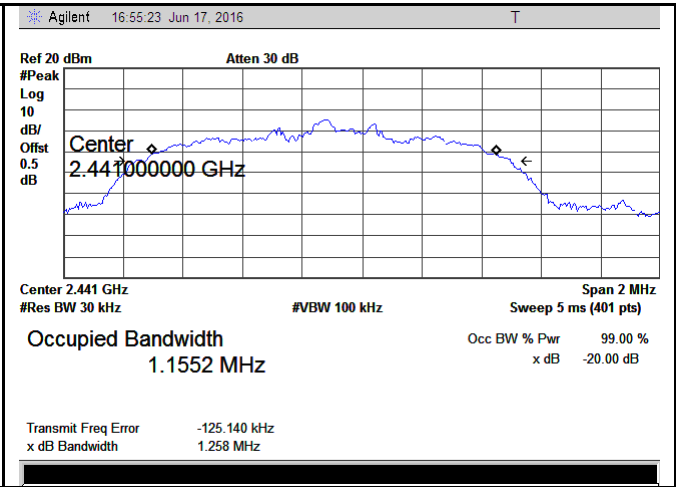

8DPSK - Middle Channel

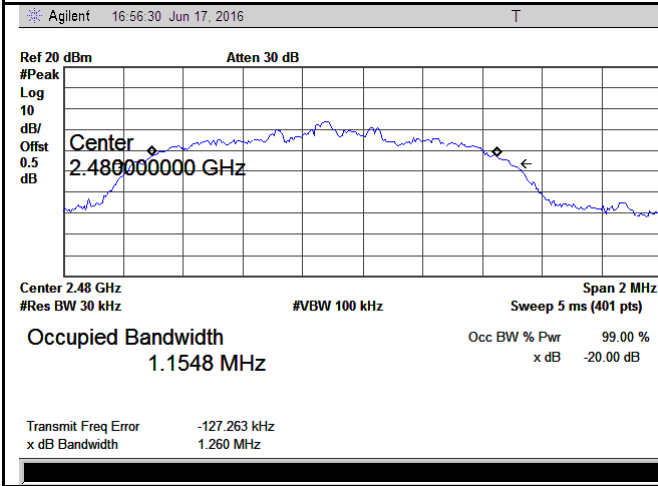

8DPSK - High Channel

6.4 Peak Output Power

Temperature	22°C
Relative Humidity	59%
Atmospheric Pressure	1017mbar
Test date :	June 17, 2016
Tested By :	Loren Luo

Requirement(s):

Spec	Item	Requirement	Applicable
§15.247(b) (3)	a)	FHSS in 2400-2483.5MHz with ≥ 75 channels: ≤ 1 Watt	<input checked="" type="checkbox"/>
	b)	FHSS in 5725-5850MHz: ≤ 1 Watt	<input type="checkbox"/>
	c)	For all other FHSS in the 2400-2483.5MHz band: ≤ 0.125 Watt.	<input checked="" type="checkbox"/>
	d)	FHSS in 902-928MHz with ≥ 50 channels: ≤ 1 Watt	<input type="checkbox"/>
	e)	FHSS in 902-928MHz with ≥ 25 & < 50 channels: ≤ 0.25 Watt	<input type="checkbox"/>
	f)	DTS in 902-928MHz, 2400-2483.5MHz: ≤ 1 Watt	<input type="checkbox"/>

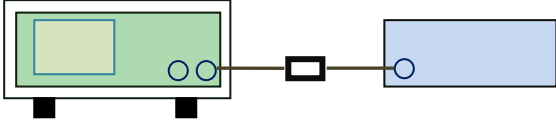
Test Setup	
------------	--

Test Procedure	<p>The test follows FCC Public Notice DA 00-705 Measurement Guidelines.</p> <p>Use the following spectrum analyzer settings:</p> <ul style="list-style-type: none"> - Span = approximately 5 times the 20 dB bandwidth, centered on a hopping channel - RBW $>$ the 20 dB bandwidth of the emission being measured - VBW \geq RBW - Sweep = auto - Detector function = peak - Trace = max hold - Allow the trace to stabilize.
----------------	--

	- Use the marker-to-peak function to set the marker to the peak of the emission. The indicated level is the peak output power (see the note above regarding external attenuation and cable loss). The limit is specified in one of the subparagraphs of this Section. Submit this plot. A peak responding power meter may be used instead of a spectrum analyzer.
Remark	
Result	<input checked="" type="checkbox"/> Pass <input type="checkbox"/> Fail

Test Data Yes N/A
 Test Plot Yes (See below) N/A

Peak Output Power measurement result

Type	Modulation	CH	Freq (MHz)	Conducted Power (dBm)	Limit (mW)	Result
Output power	GFSK	Low	2402	-1.117	125	Pass
		Mid	2441	-2.154	125	Pass
		High	2480	-3.398	125	Pass
	π /4 DQPSK	Low	2402	-2.682	125	Pass
		Mid	2441	-2.807	125	Pass
		High	2480	-4.038	125	Pass
	8DPSK	Low	2402	-1.543	125	Pass
		Mid	2441	-2.663	125	Pass
		High	2480	-3.641	125	Pass

Test Plots

Output Power measurement result

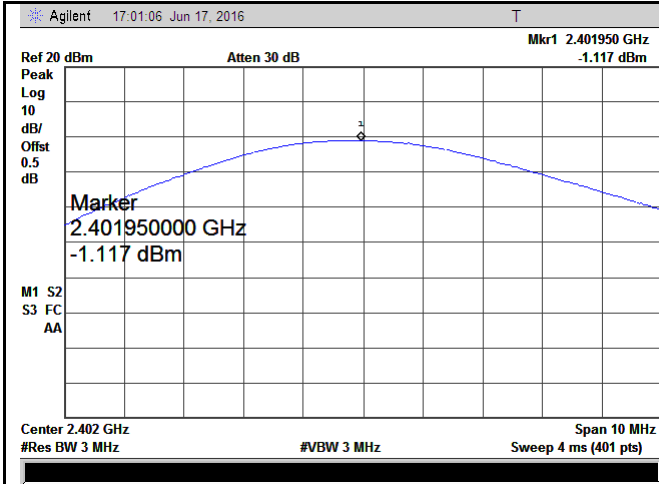

GFSK Output power - Low CH 2402

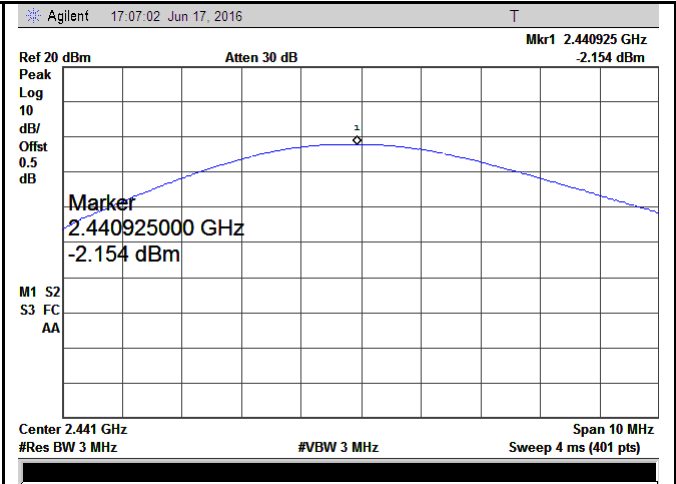

GFSK Output power - Mid CH 2441

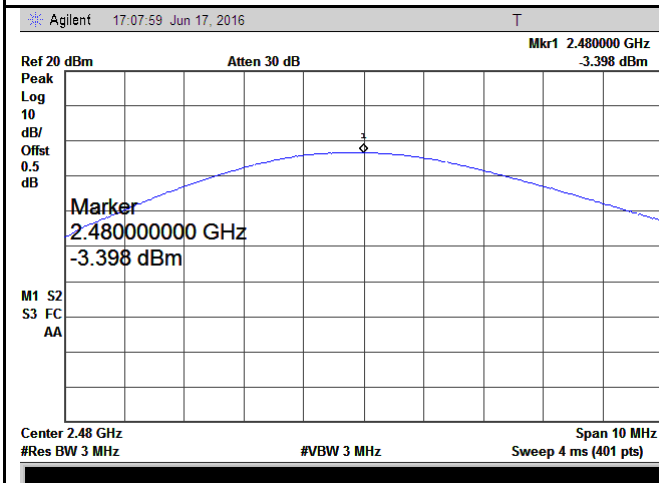

GFSK Output power - High CH 2480

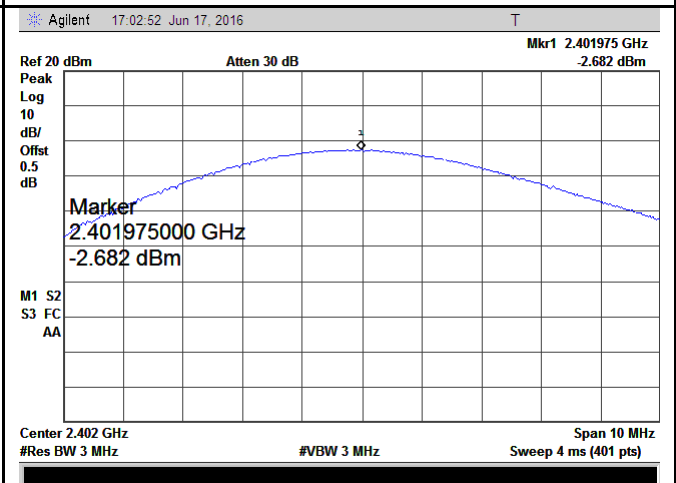

$\pi/4$ DQPSK Output power - Low CH 2402

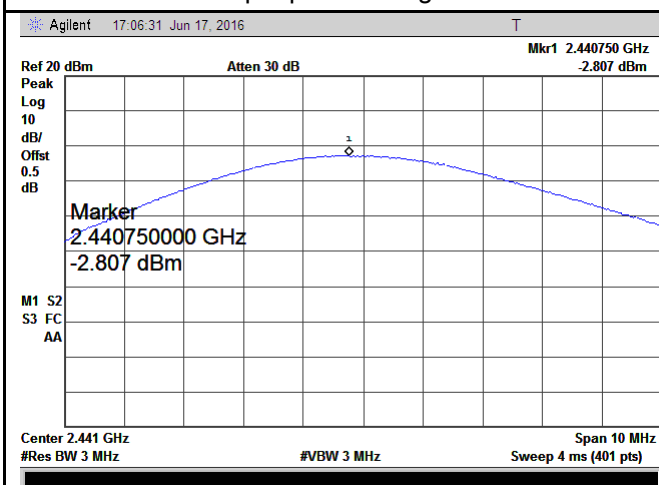

$\pi/4$ DQPSK Output power - Mid CH 2441

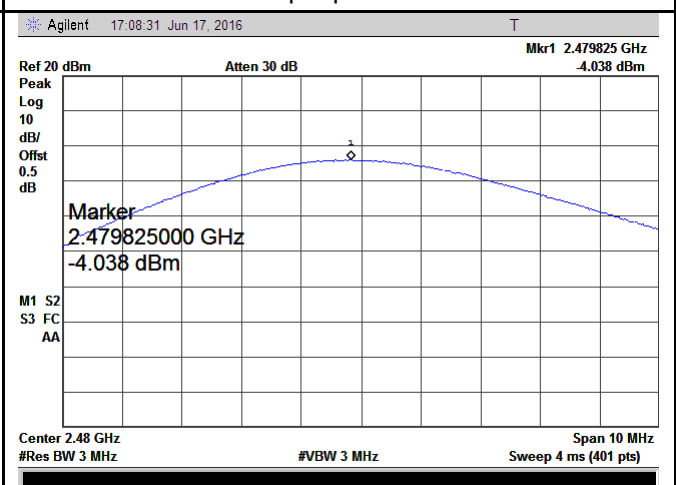

$\pi/4$ DQPSK Output power - High CH 2480

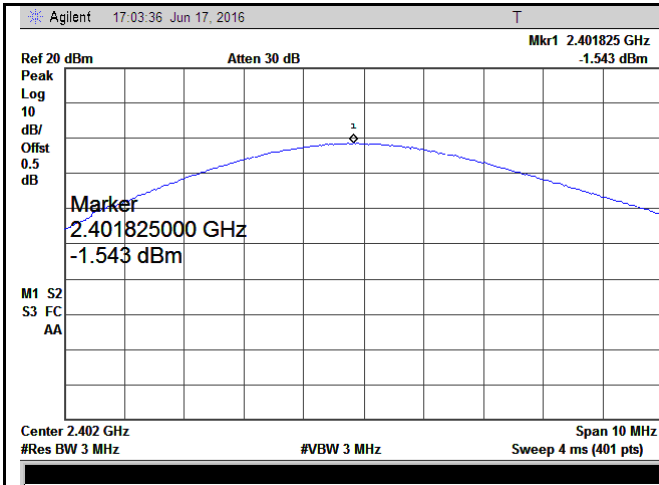

8DPSK Output power - Low CH 2402

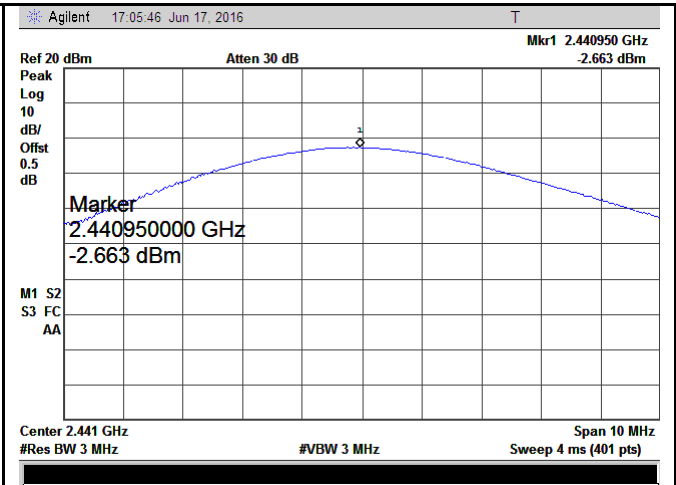

8DPSK Output power - Mid CH 2441

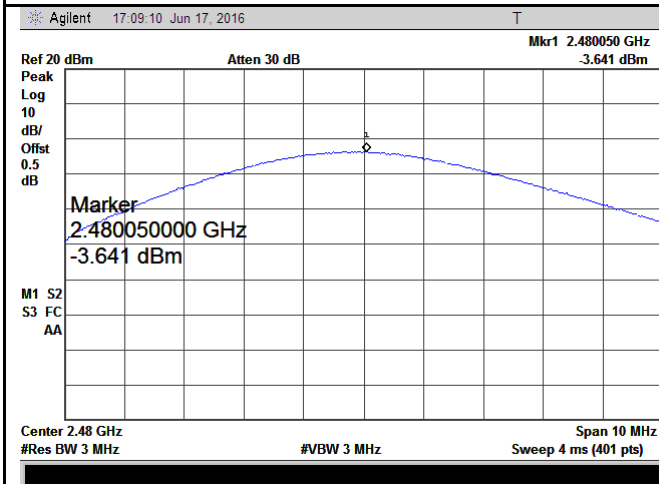

8DPSK Output power - High CH 2480

6.5 Number of Hopping Channel

Temperature	22°C
Relative Humidity	59%
Atmospheric Pressure	1017mbar
Test date :	June 17, 2016
Tested By :	Loren Luo

Requirement(s):

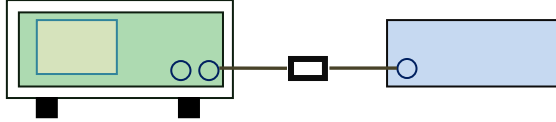
Spec	Item	Requirement	Applicable
§15.247(a) (1)(iii)	a)	FHSS in 2400-2483.5MHz ≥ 15 channels	<input checked="" type="checkbox"/>
Test Setup			
Test Procedure	<p>The test follows FCC Public Notice DA 00-705 Measurement Guidelines. <u>Use the following spectrum analyzer settings:</u> The EUT must have its hopping function enabled.</p> <ul style="list-style-type: none"> - Span = the frequency band of operation - RBW ≥ 1% of the span - VBW ≥ RBW - Sweep = auto - Detector function = peak - Trace = max hold - Allow trace to fully stabilize. - It may prove necessary to break the span up to sections, in order to clearly show all of the hopping frequencies. The limit is specified in one of the subparagraphs of this Section. Submit this plot(s). 		
Remark			
Result	<input checked="" type="checkbox"/> Pass <input type="checkbox"/> Fail		

Test Data Yes N/A
 Test Plot Yes (See below) N/A

Number of Hopping Channel measurement result

Type	Modulation	Frequency Range	Number of Hopping Channel	Limit
Number of Hopping Channel	GFSK	2400-2483.5	79	15
	$\pi/4$ DQPSK	2400-2483.5	79	15
	8-DPSK	2400-2483.5	79	15

Test Plots

Number of Hopping Channels measurement result

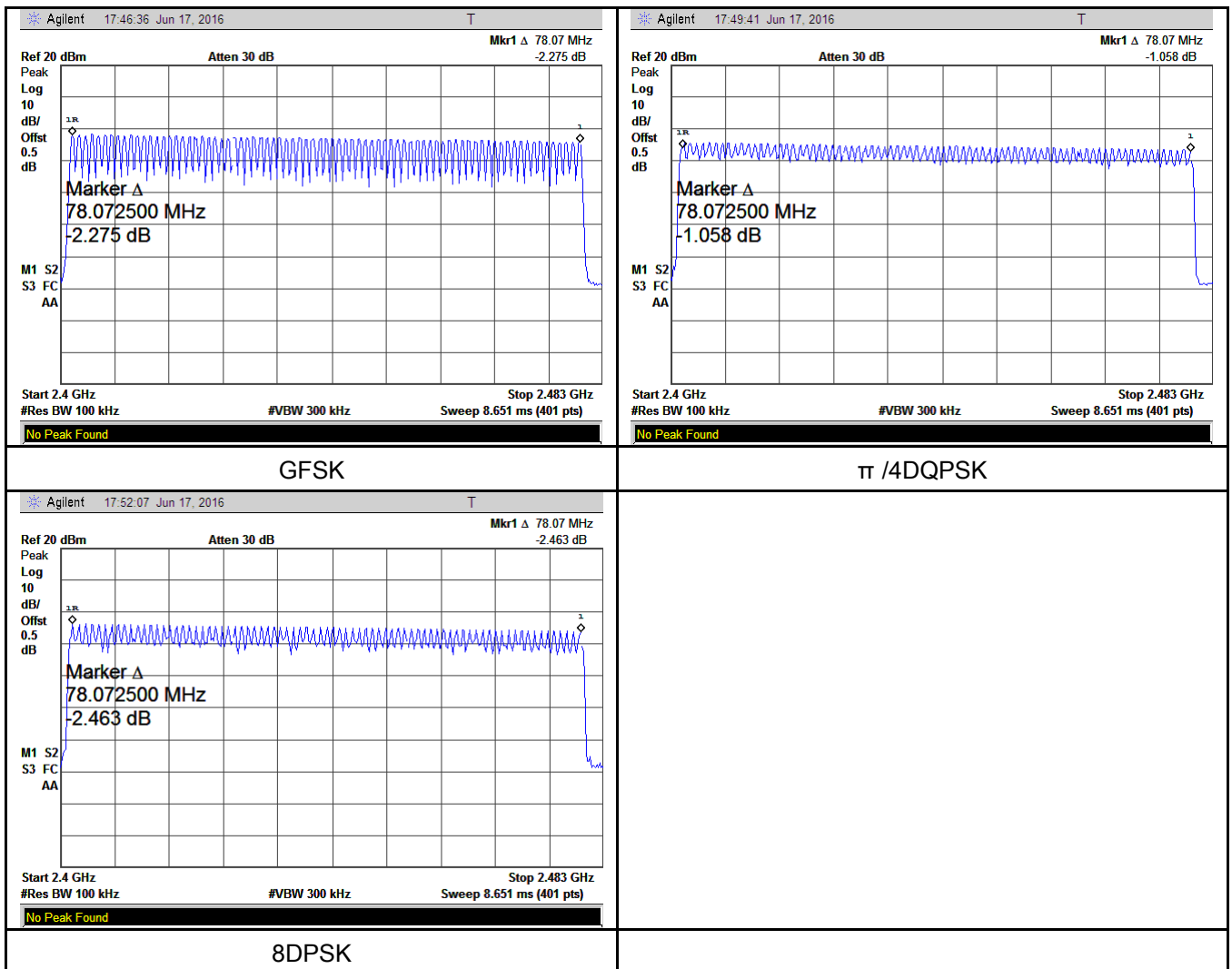

6.6 Time of Occupancy (Dwell Time)

Temperature	22°C
Relative Humidity	59%
Atmospheric Pressure	1017mbar
Test date :	June 17, 2016
Tested By :	Loren Luo

Requirement(s):

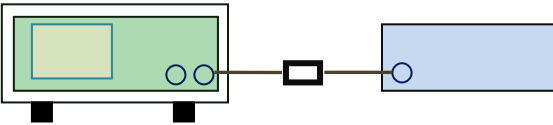
Spec	Item	Requirement	Applicable
§15.247(a) (1)(iii)	a)	Dwell Time < 0.4s	<input checked="" type="checkbox"/>
Test Setup			
Test Procedure	<p>The test follows FCC Public Notice DA 00-705 Measurement Guidelines. <u>Use the following spectrum analyzer</u></p> <ul style="list-style-type: none"> - Span = zero span, centered on a hopping channel - RBW = 1 MHz - VBW ≥ RBW - Sweep = as necessary to capture the entire dwell time per hopping channel - Detector function = peak - Trace = max hold - use the marker-delta function to determine the dwell time 		
Remark			
Result	<input checked="" type="checkbox"/> Pass <input type="checkbox"/> Fail		

Test Data Yes N/A
 Test Plot Yes (See below) N/A

Dwell Time measurement result

Type	Modulation	CH	Pulse Width (ms)	Dwell Time (ms)	Limit (ms)	Result
Dwell Time	GFSK	Low	2.992	319.147	400	Pass
		Mid	2.992	319.147	400	Pass
		High	2.970	316.800	400	Pass
	π /4 DQPSK	Low	3.015	321.600	400	Pass
		Mid	3.015	321.600	400	Pass
		High	3.015	321.600	400	Pass
	8DPSK	Low	3.015	321.600	400	Pass
		Mid	3.015	321.600	400	Pass
		High	3.015	321.600	400	Pass
Note: Dwell time=Pulse Time (ms) × (1600 ÷ 6 ÷ 79) ×31.6						

Test Plots

Dwell Time measurement result

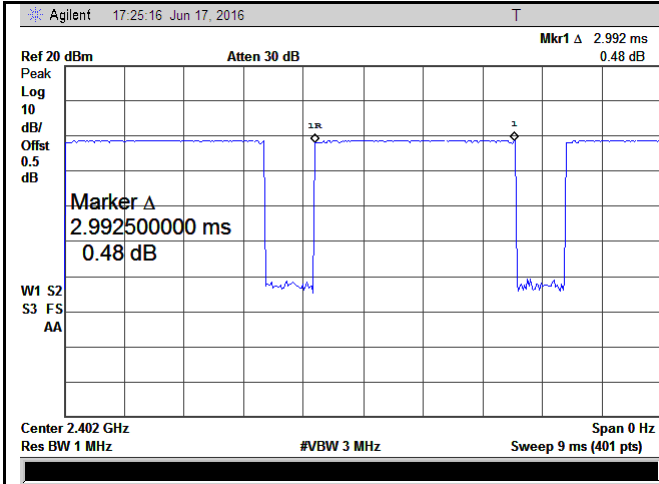

GFSK - Low CH 2402

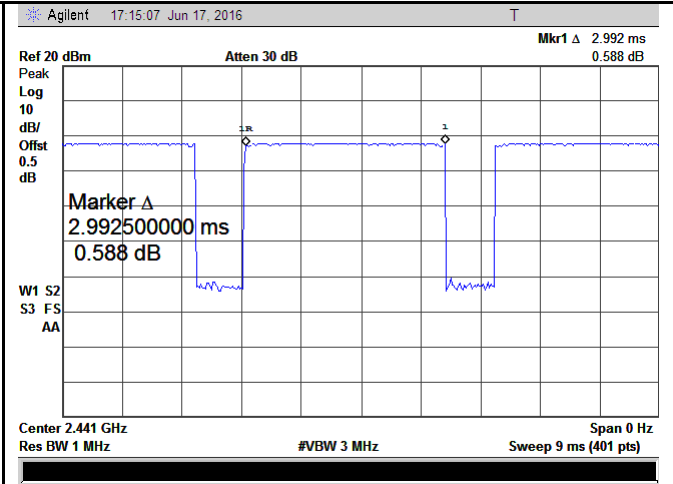

GFSK - Mid CH 2441

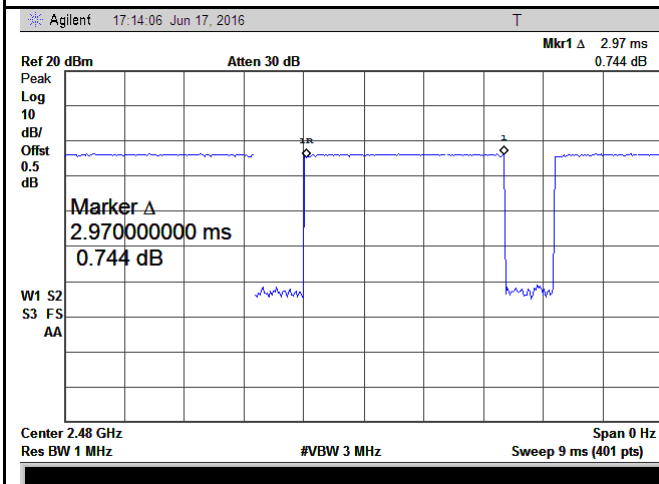

GFDK - High CH 2480

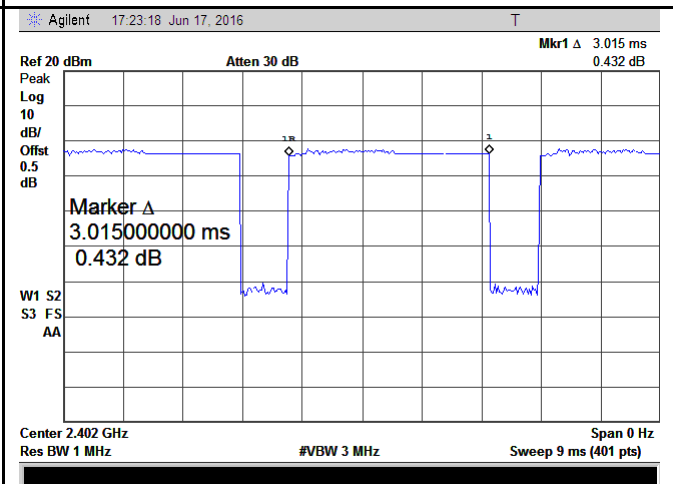

$\pi/4$ DQPSK - Low CH 2402

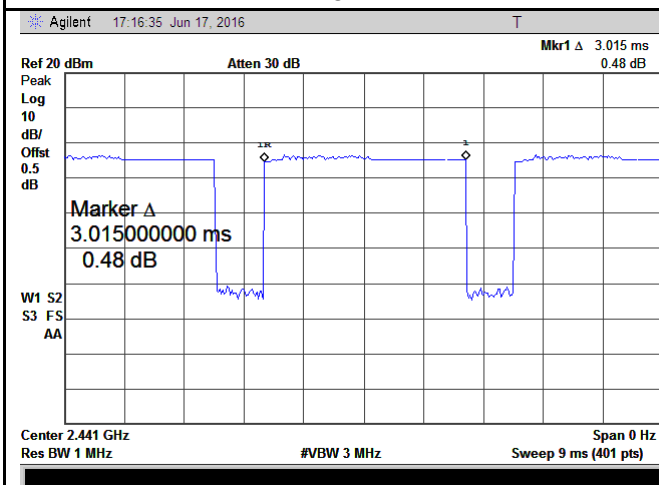

$\pi/4$ DQPSK - Mid CH 2441

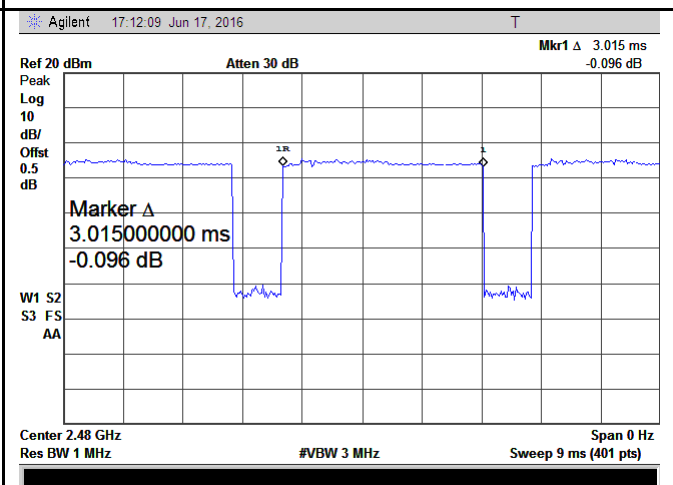

$\pi/4$ DQPSK - High CH 2480

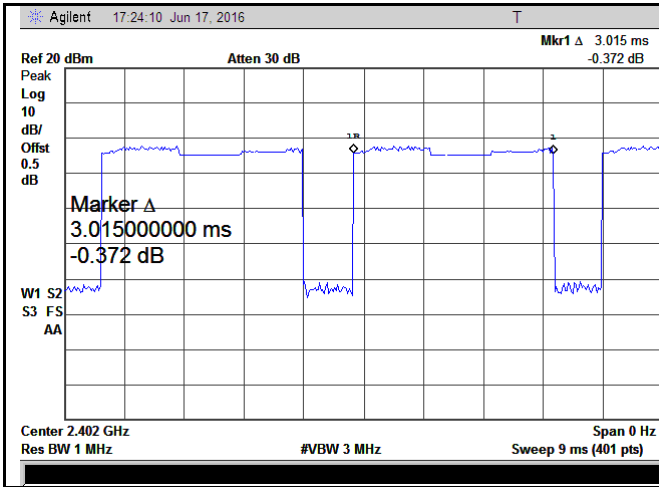

8DPSK - Low CH 2402

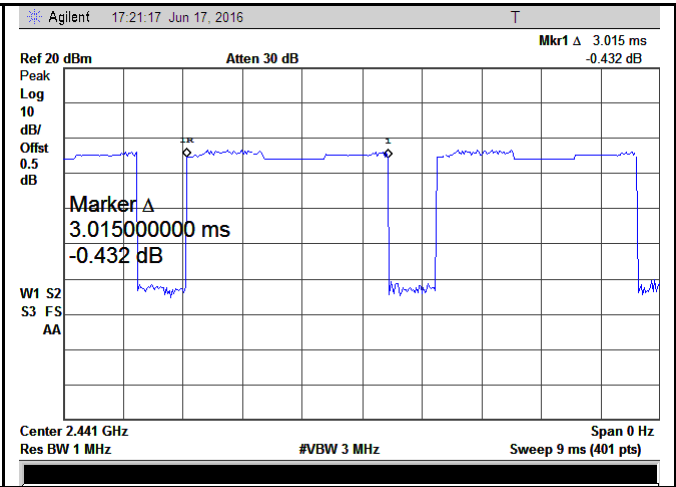

8DPSK - Mid CH 2441

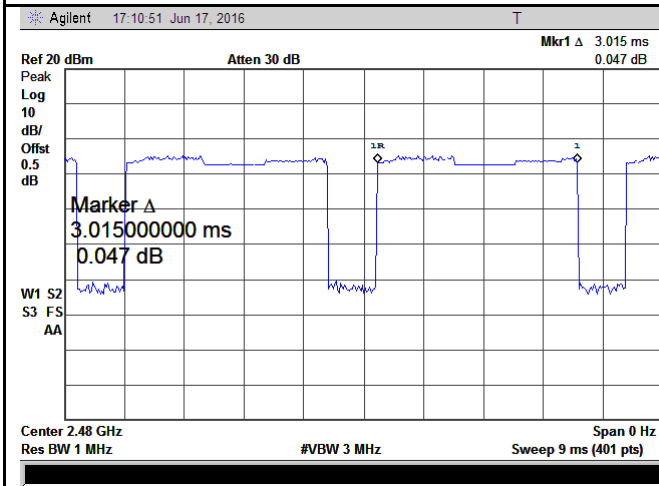

8DPSK - High CH 2480

6.7 Band Edge

Temperature	23°C
Relative Humidity	55%
Atmospheric Pressure	1022mbar
Test date :	June 22, 2016
Tested By :	Loren Luo

Requirement(s):

Spec	Item	Requirement	Applicable
§15.247(a) (1)(iii)	a)	In any 100 kHz bandwidth outside the frequency band in which the spread spectrum or digitally modulated intentional radiator is operating, the radio frequency power that is produced by the intentional radiator shall be at least 20 dB below that in the 100 kHz bandwidth within the band that contains the highest level of the desired power, based on either an RF conducted or a radiated measurement, provided the transmitter demonstrates compliance with the peak conducted power limits.	<input checked="" type="checkbox"/>

Test Setup	
------------	--

Test Procedure	<p>The test follows FCC Public Notice DA 00-705 Measurement Guidelines. Radiated Method Only</p> <ul style="list-style-type: none"> - 1. Check the calibration of the measuring instrument using either an internal calibrator or a known signal from an external generator. - 2. Position the EUT without connection to measurement instrument. Put it on the Rotated table and turn on the EUT and make it operate in transmitting mode. Then set it to Low Channel and High Channel within its operating range,
----------------	--

Test Report	16070642-FCC-R
Page	28 of 57

	<p>and make sure the instrument is operated in its linear range.</p> <ul style="list-style-type: none"> - 3. First, set both RBW and VBW of spectrum analyzer to 100 kHz with a convenient frequency span including 100kHz bandwidth from band edge, check the emission of EUT, if pass then set Spectrum Analyzer as below: <ul style="list-style-type: none"> a. The resolution bandwidth and video bandwidth of test receiver/spectrum analyzer is 120 kHz for Quasiy Peak detection at frequency below 1GHz. b. The resolution bandwidth of test receiver/spectrum analyzer is 1MHz and video bandwidth is 3MHz with Peak detection for Peak measurement at frequency above 1GHz. c. The resolution bandwidth of test receiver/spectrum analyzer is 1MHz and the video bandwidth is 10Hz with Peak detection for Average Measurement as below at frequency above 1GHz. - 4. Measure the highest amplitude appearing on spectral display and set it as a reference level. Plot the graph with marking the highest point and edge frequency. - 5. Repeat above procedures until all measured frequencies were complete.
Remark	
Result	<input checked="" type="checkbox"/> Pass <input type="checkbox"/> Fail

Test Data Yes N/A
 Test Plot Yes (See below) N/A

Test Plots

GFSK Mode:

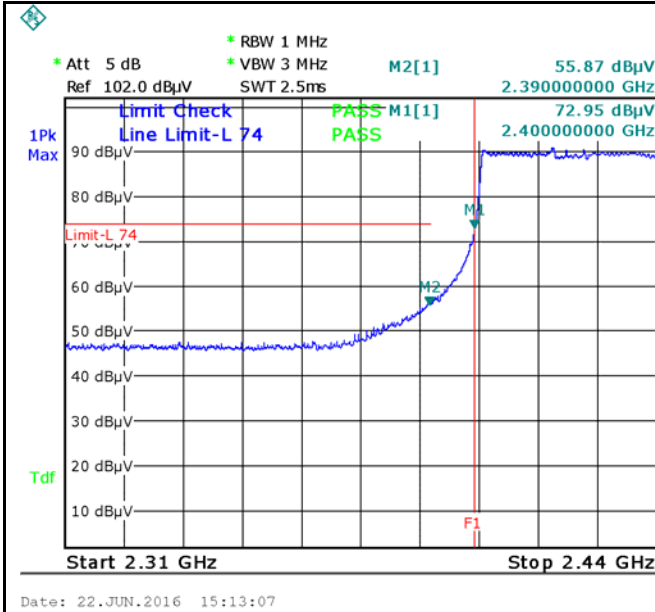

GFSK-Hopping Left Side-PK
 Note: F1 is frequency 2400MHz

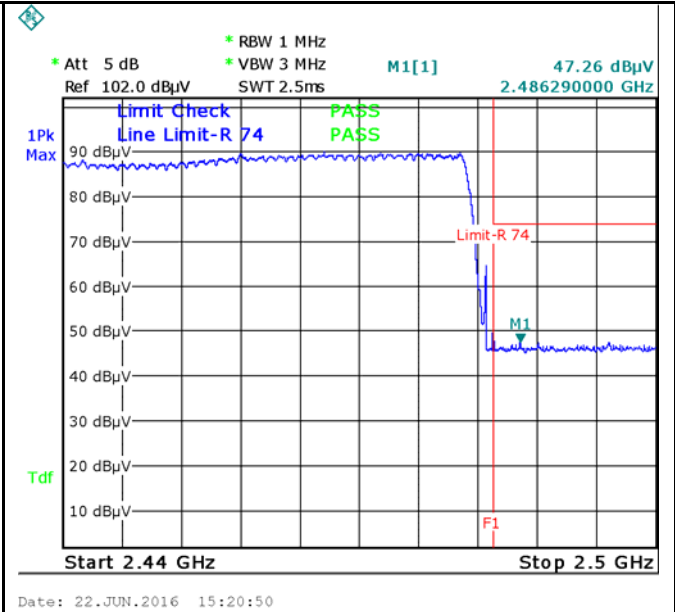

GFSK-Hopping Right Side-PK
 Note: F1 is frequency 2483.5MHz

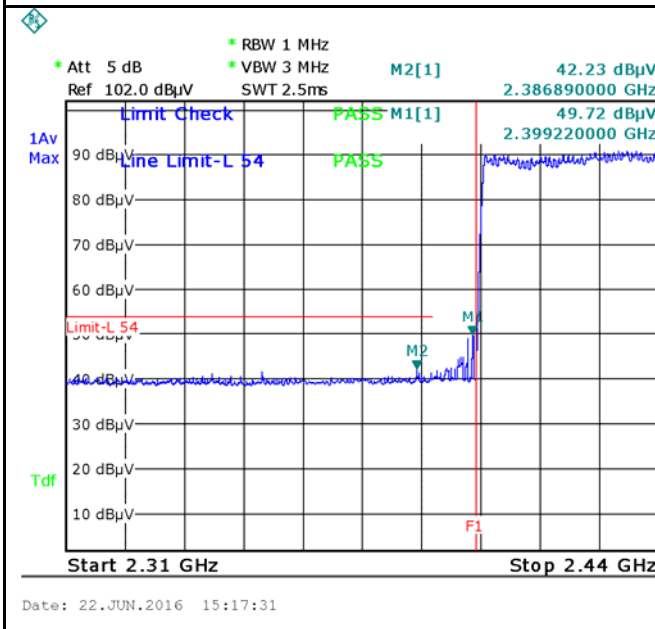

Note: (no need if PK value less than the AV limit)

GFSK-Hopping Left Side-AV

GFSK-Hopping Right Side-AV

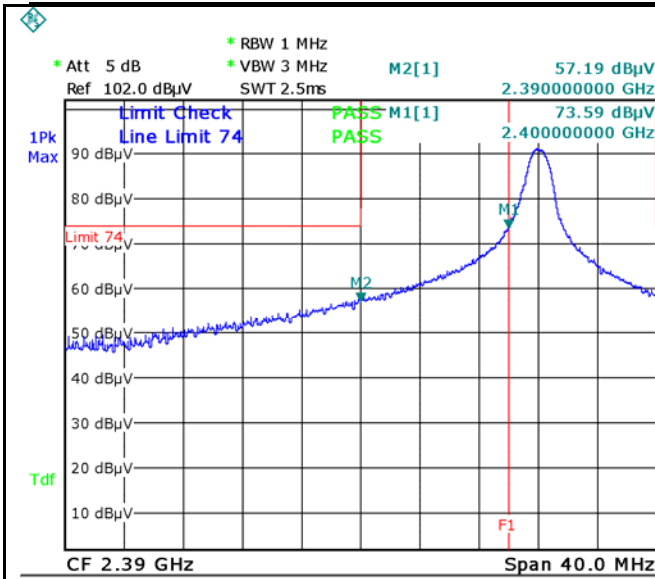

Date: 22.JUN.2016 14:08:23

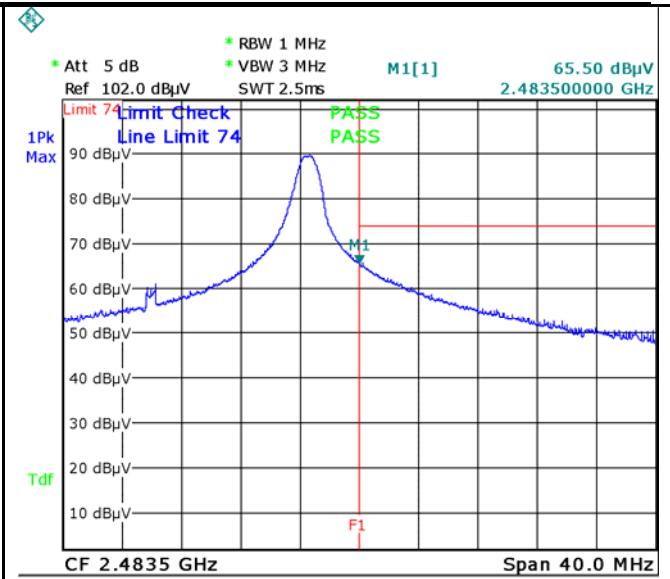

Date: 22.JUN.2016 14:20:34

GFSK-Left Side-PK

Note: F1 is frequency 2400MHz

GFSK-Right Side-PK

Note: F1 is frequency 2483.5MHz

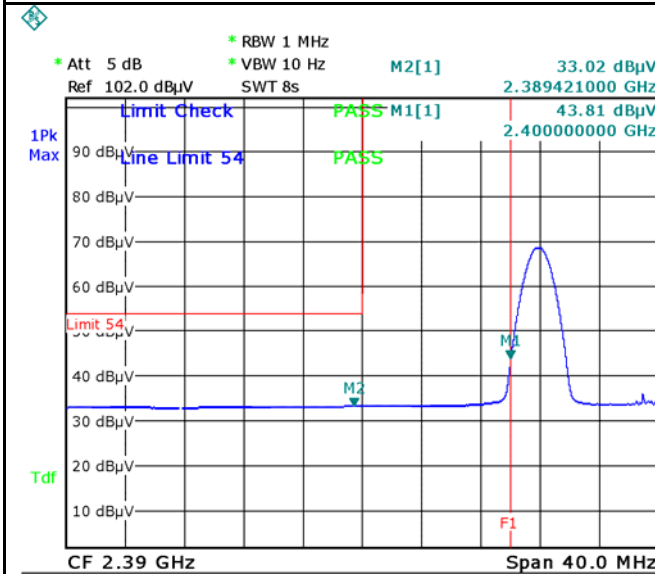

Date: 22.JUN.2016 14:12:52

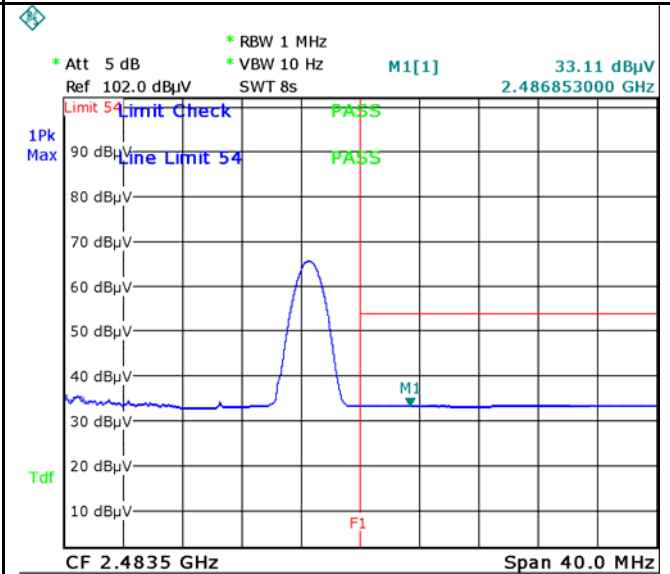

Date: 22.JUN.2016 14:26:31

GFSK-Left Side-AV

GFSK-Right Side-AV

$\pi/4$ DQPSK Mode:

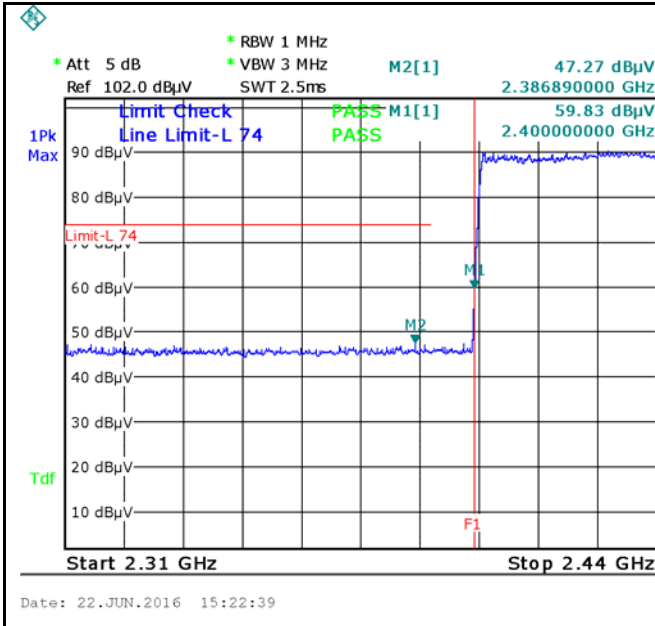

$\pi/4$ DQPSK-Hopping Left Side-PK
 Note: F1 is frequency 2400MHz

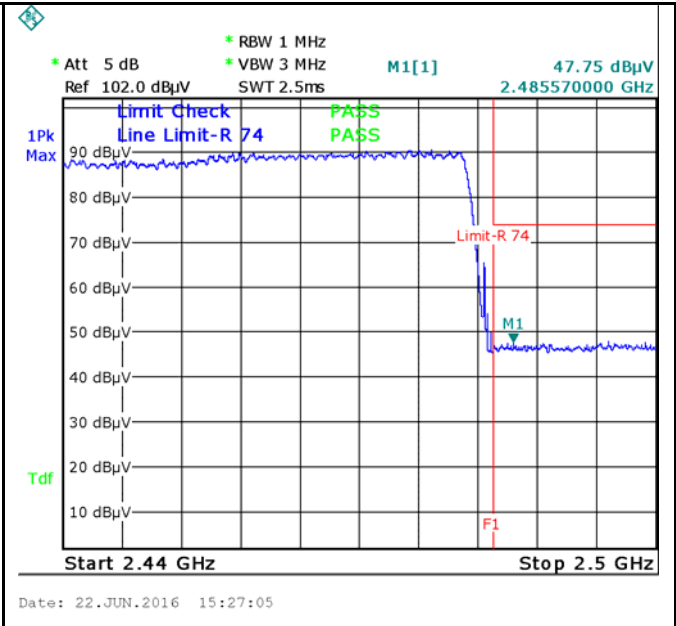

$\pi/4$ DQPSK-Hopping Right Side-PK
 Note: F1 is frequency 2483.5MHz

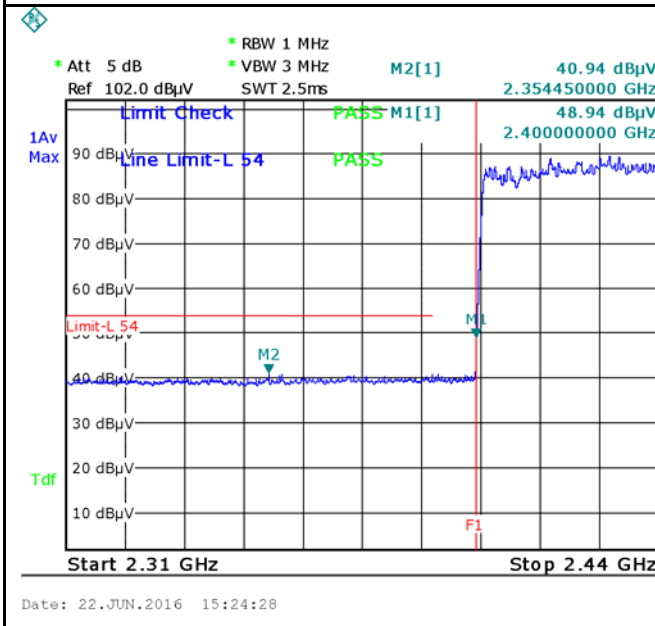

$\pi/4$ DQPSK-Hopping Left-AV

Note: (no need if PK value less than the AV limit)

$\pi/4$ DQPSK-Hopping Right-AV

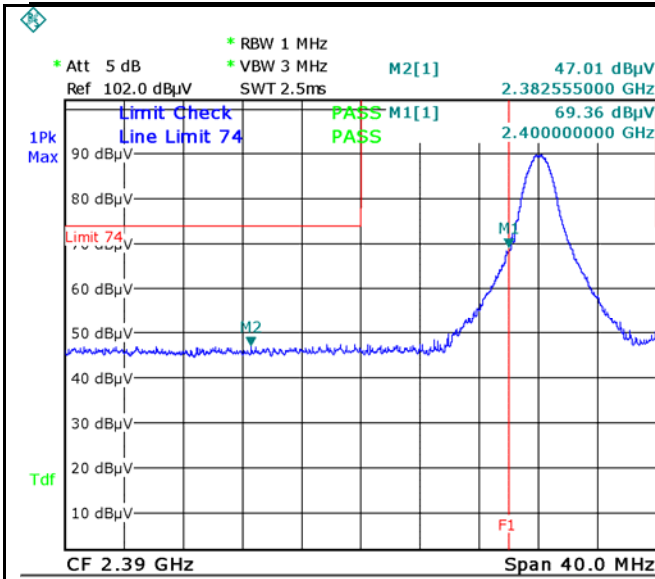

Date: 22.JUN.2016 14:39:50

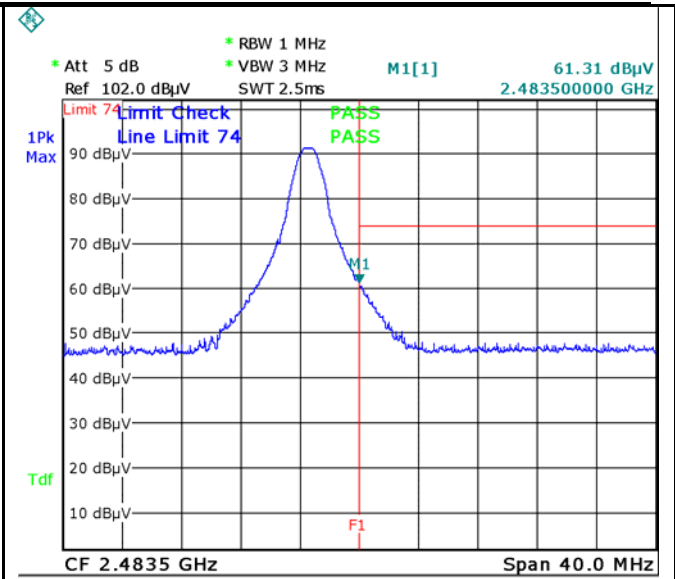

Date: 29.DEC.2015 15:41:02

$\pi/4$ DQPSK-Left Side-PK
Note: F1 is frequency 2400MHz

$\pi/4$ DQPSK-Right Side-PK
Note: F1 is frequency 2483.5MHz

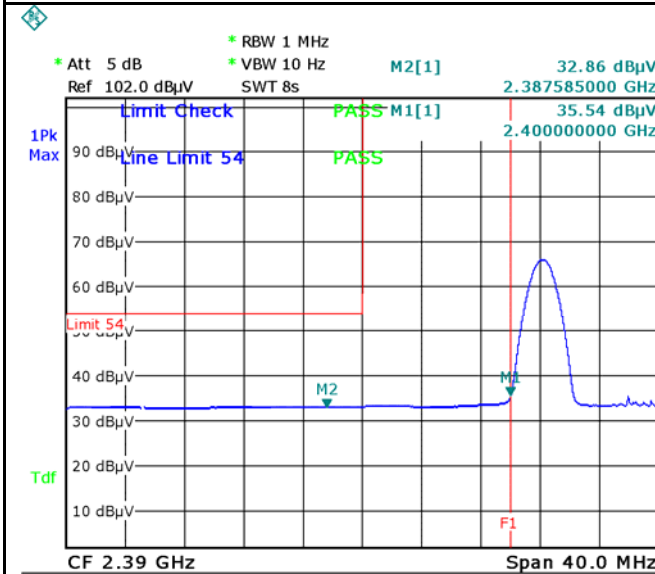

Date: 22.JUN.2016 14:35:50

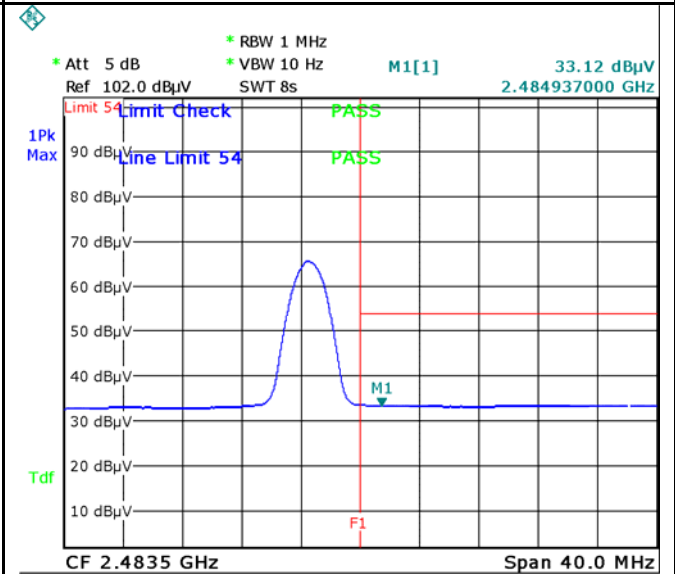

Date: 22.JUN.2016 14:41:55

$\pi/4$ DQPSK-Left Side-AV

$\pi/4$ DQPSK-Right Side-AV

8DPSK Mode:

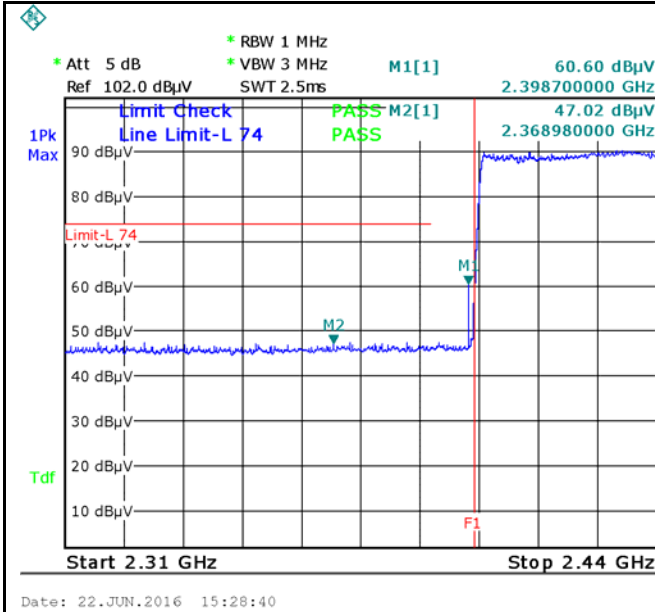

8DPSK-Hopping Left Side-PK
 Note: F1 is frequency 2400MHz

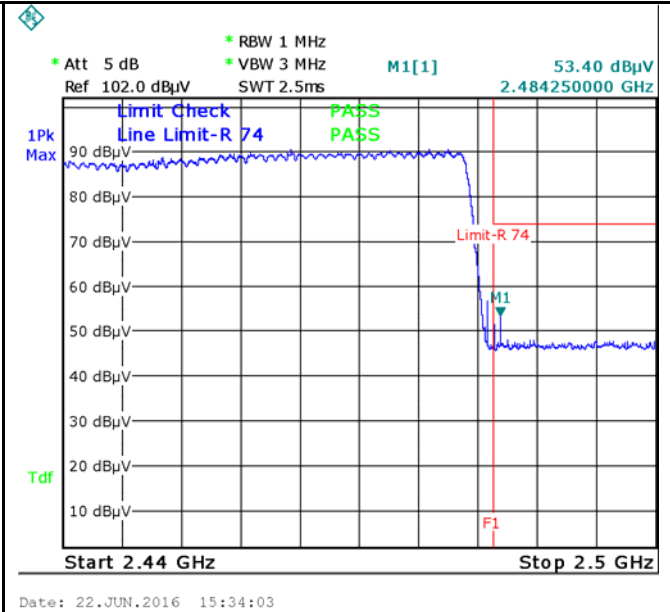

8DPSK--Hopping Right Side-PK
 Note: F1 is frequency 2483.5MHz

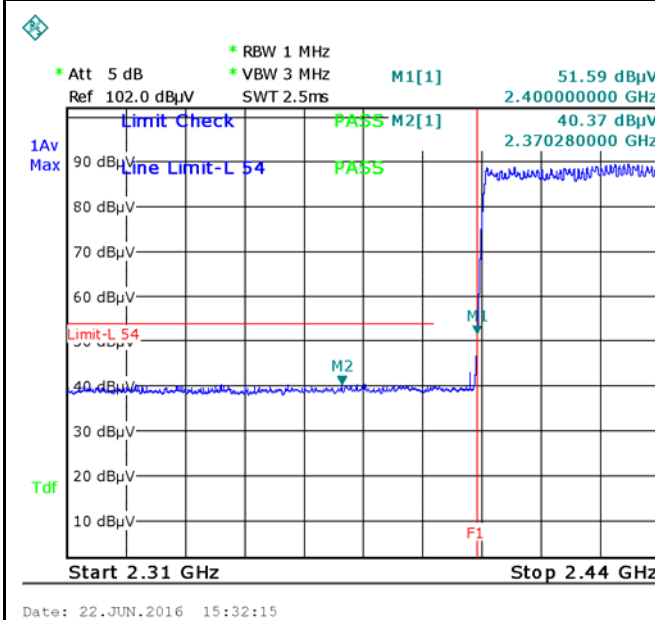

8DPSK--Hopping Left-AV

Note: (no need if PK value less than the AV limit)

8DPSK--Hopping Right-AV

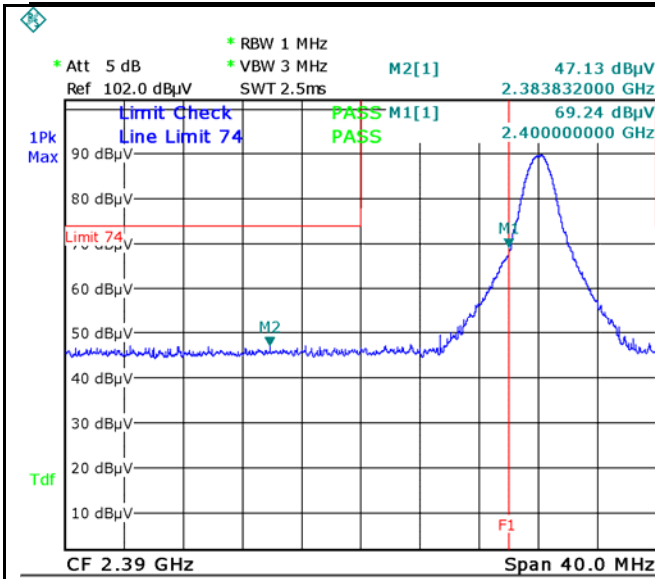

Date: 22.JUN.2016 14:46:32

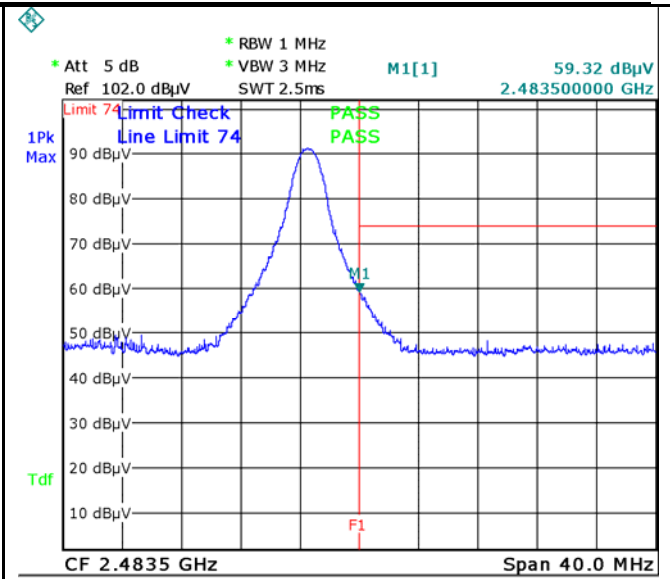

Date: 22.JUN.2016 14:53:02

8DPSK--Left Side-PK
Note: F1 is frequency 2400MHz

8DPSK--Right Side-PK
Note: F1 is frequency 2483.5MHz

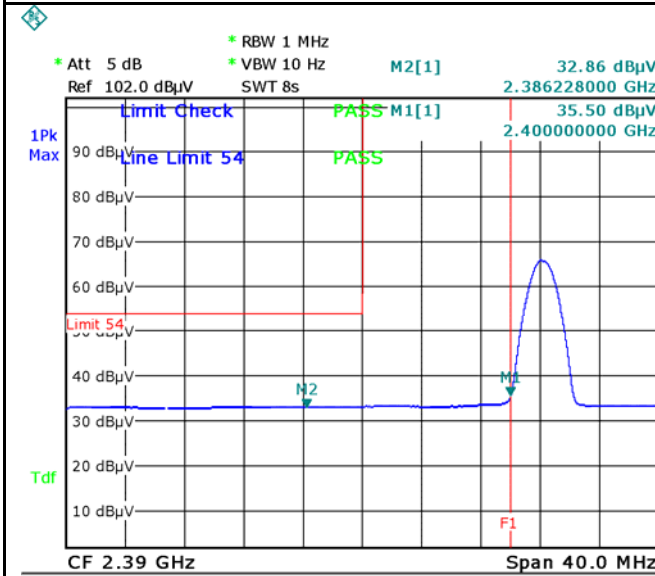

Date: 22.JUN.2016 14:49:19

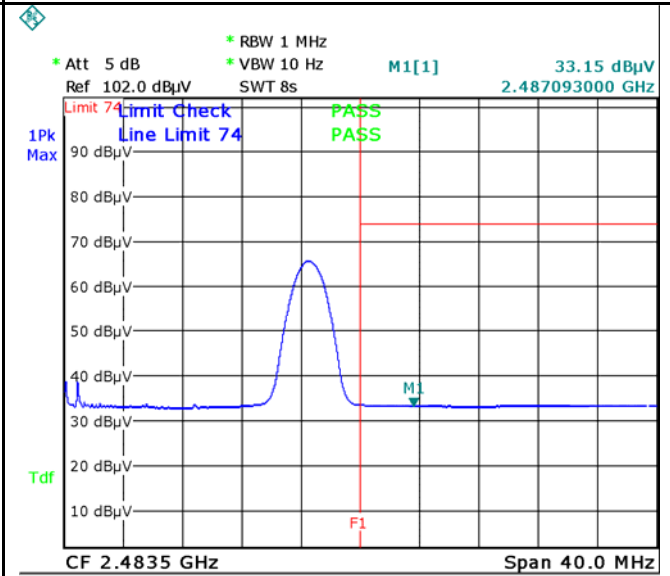

Date: 22.JUN.2016 15:07:04

8DPSK--Left Side-AV

8DPSK--Right Side-AV

6.8 AC Power Line Conducted Emissions

Temperature	23°C
Relative Humidity	55%
Atmospheric Pressure	1022mbar
Test date :	June 22, 2016
Tested By :	Loren Luo

Requirement(s):

Spec	Item	Requirement	Applicable														
47CFR§15.207, RSS210 (A8.1)	a)	For Low-power radio-frequency devices that is designed to be connected to the public utility (AC) power line, the radio frequency voltage that is conducted back onto the AC power line on any frequency or frequencies, within the band 150 kHz to 30 MHz, shall not exceed the limits in the following table, as measured using a 50 [μ]H/50 ohms line impedance stabilization network (LISN). The lower limit applies at the boundary between the frequencies ranges.	<input checked="" type="checkbox"/>														
		<table border="1"> <thead> <tr> <th rowspan="2">Frequency ranges (MHz)</th> <th colspan="2">Limit (dBμV)</th> </tr> <tr> <th>QP</th> <th>Average</th> </tr> </thead> <tbody> <tr> <td>0.15 ~ 0.5</td> <td>66 – 56</td> <td>56 – 46</td> </tr> <tr> <td>0.5 ~ 5</td> <td>56</td> <td>46</td> </tr> <tr> <td>5 ~ 30</td> <td>60</td> <td>50</td> </tr> </tbody> </table>		Frequency ranges (MHz)	Limit (dBμV)		QP	Average	0.15 ~ 0.5	66 – 56	56 – 46	0.5 ~ 5	56	46	5 ~ 30	60	50
		Frequency ranges (MHz)			Limit (dBμV)												
				QP	Average												
0.15 ~ 0.5	66 – 56	56 – 46															
0.5 ~ 5	56	46															
5 ~ 30	60	50															

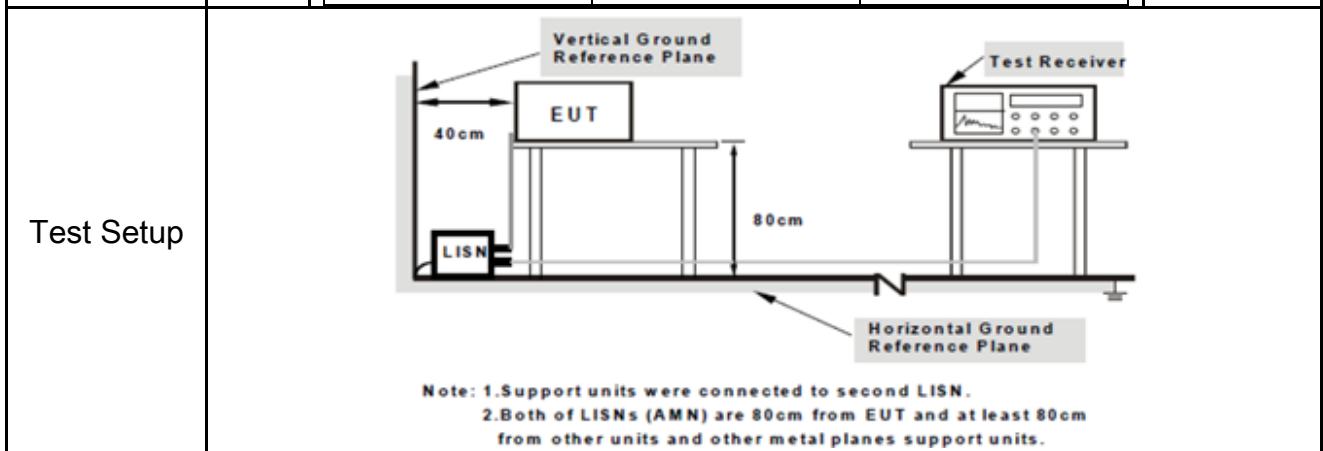

Procedure	<ol style="list-style-type: none"> The EUT and supporting equipment were set up in accordance with the requirements of the standard on top of a 1.5m x 1m x 0.8m high, non-metallic table. The power supply for the EUT was fed through a 50W/50mH EUT LISN, connected to filtered mains. The RF OUT of the EUT LISN was connected to the EMI test receiver via a low-loss
-----------	---

Test Report	16070642-FCC-R
Page	36 of 57

	<p>coaxial cable.</p> <ol style="list-style-type: none"> 4. All other supporting equipment were powered separately from another main supply. 5. The EUT was switched on and allowed to warm up to its normal operating condition. 6. A scan was made on the NEUTRAL line (for AC mains) or Earth line (for DC power) over the required frequency range using an EMI test receiver. 7. High peaks, relative to the limit line, The EMI test receiver was then tuned to the selected frequencies and the necessary measurements made with a receiver bandwidth setting of 10 kHz. 8. Step 7 was then repeated for the LIVE line (for AC mains) or DC line (for DC power).
Remark	
Result	<input checked="" type="checkbox"/> Pass <input type="checkbox"/> Fail

Test Data Yes N/A

Test Plot Yes (See below) N/A

Test Mode : Bluetooth Mode

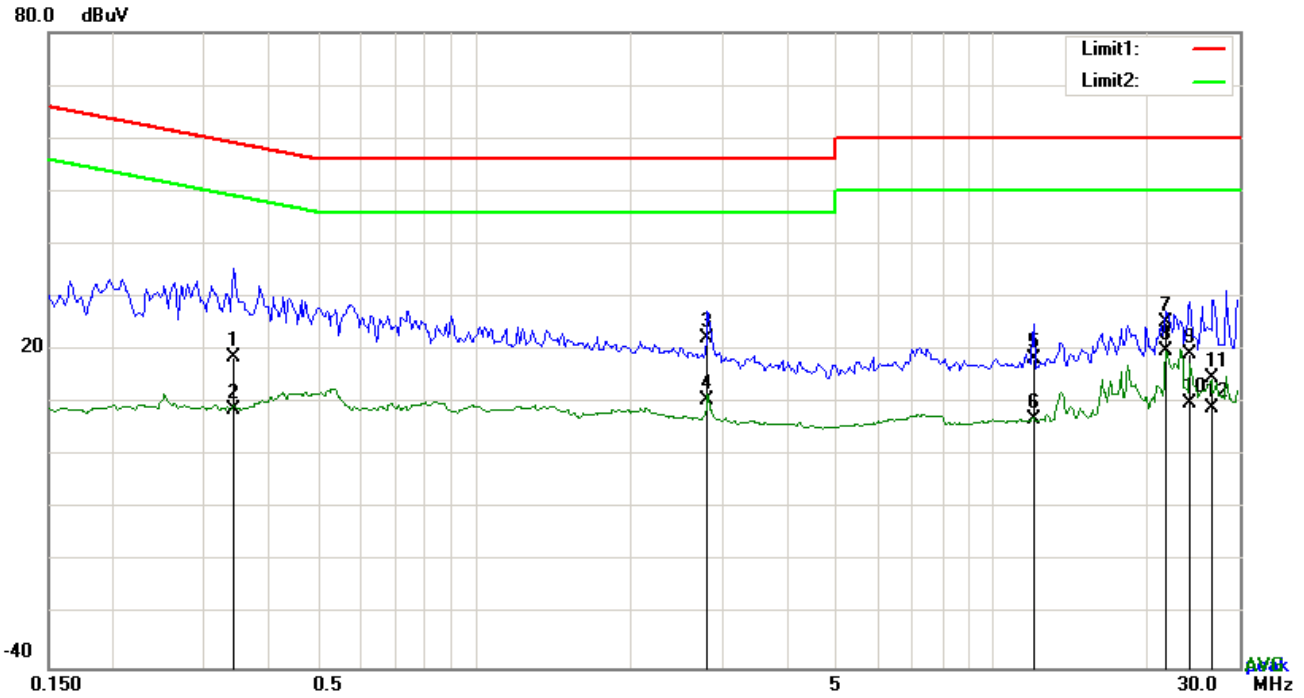

Test Data

Phase Line Plot at 120Vac, 60Hz

No.	P/L	Frequency	Reading	Detector	Corrected	Result	Limit	Margin
		(MHz)	(dBuV)		(dB}	(dBuV)	(dBuV)	(dB)
1	L1	0.3411	8.61	QP	10.03	18.64	59.18	-40.54
2	L1	0.3411	-1.19	AVG	10.03	8.84	49.18	-40.34
3	L1	2.8215	12.15	QP	10.05	22.20	56.00	-33.80
4	L1	2.8215	0.51	AVG	10.05	10.56	46.00	-35.44
5	L1	12.0012	8.22	QP	10.18	18.40	60.00	-41.60
6	L1	12.0012	-3.22	AVG	10.18	6.96	50.00	-43.04
7	L1	21.6654	15.02	QP	10.33	25.35	60.00	-34.65
8	L1	21.6654	9.67	AVG	10.33	20.00	50.00	-30.00
9	L1	24.0327	8.79	QP	10.38	19.17	60.00	-40.83
10	L1	24.0327	-0.47	AVG	10.38	9.91	50.00	-40.09
11	L1	26.6925	4.38	QP	10.43	14.81	60.00	-45.19
12	L1	26.6925	-1.45	AVG	10.43	8.98	50.00	-41.02

Test Mode : Bluetooth Mode

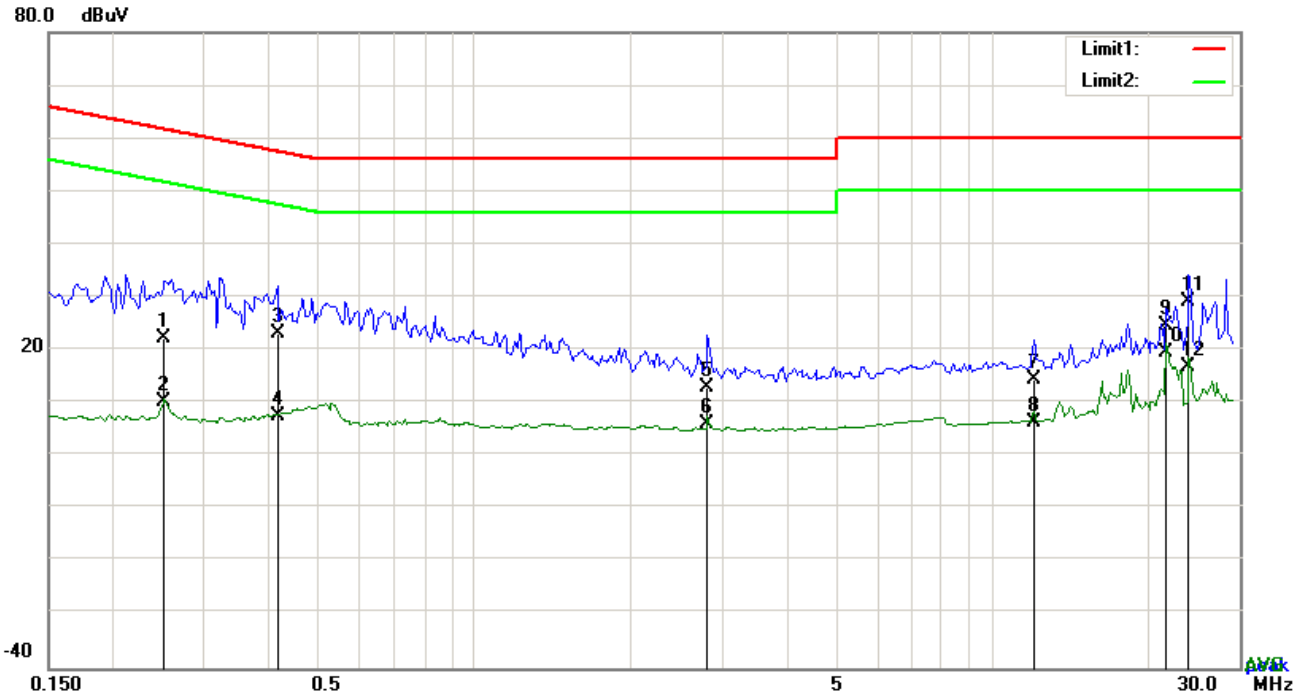

Test Data

Phase Neutral Plot at 120Vac, 60Hz

No.	P/L	Frequency	Reading	Detector	Corrected	Result	Limit	Margin
		(MHz)	(dBuV)		(dB}	(dBuV)	(dBuV)	(dB)
1	N	0.2514	12.38	QP	10.02	22.40	61.71	-39.31
2	N	0.2514	0.15	AVG	10.02	10.17	51.71	-41.54
3	N	0.4152	12.99	QP	10.02	23.01	57.54	-34.53
4	N	0.4152	-2.35	AVG	10.02	7.67	47.54	-39.87
5	N	2.8176	2.83	QP	10.05	12.88	56.00	-43.12
6	N	2.8176	-4.00	AVG	10.05	6.05	46.00	-39.95
7	N	12.0012	4.37	QP	10.16	14.53	60.00	-45.47
8	N	12.0012	-3.75	AVG	10.16	6.41	50.00	-43.59
9	N	21.6654	14.35	QP	10.29	24.64	60.00	-35.36
10	N	21.6654	9.14	AVG	10.29	19.43	50.00	-30.57
11	N	24.0015	18.69	QP	10.32	29.01	60.00	-30.99
12	N	24.0015	6.63	AVG	10.32	16.95	50.00	-33.05

Test Mode :	Bluetooth Mode
--------------------	-----------------------

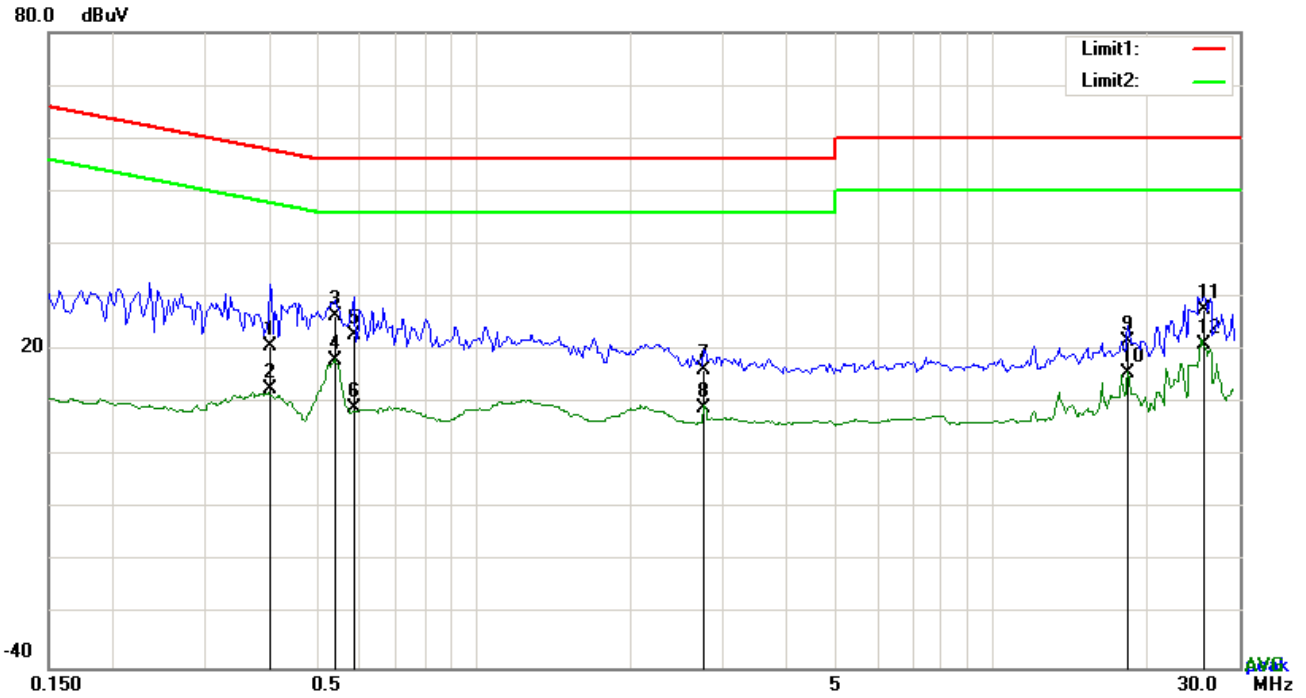

Test Data

Phase Line Plot at 240Vac, 60Hz

No.	P/L	Frequency	Reading	Detector	Corrected	Result	Limit	Margin
		(MHz)	(dBuV)		(dB)	(dBuV)	(dBuV)	(dB)
1	L1	0.4035	10.70	QP	10.03	20.73	57.78	-37.05
2	L1	0.4035	2.59	AVG	10.03	12.62	47.78	-35.16
3	L1	0.5361	16.39	QP	10.03	26.42	56.00	-29.58
4	L1	0.5361	8.14	AVG	10.03	18.17	46.00	-27.83
5	L1	0.5829	12.83	QP	10.03	22.86	56.00	-33.14
6	L1	0.5829	-1.12	AVG	10.03	8.91	46.00	-37.09
7	L1	2.7747	6.32	QP	10.05	16.37	56.00	-39.63
8	L1	2.7747	-1.05	AVG	10.05	9.00	46.00	-37.00
9	L1	18.2451	11.25	QP	10.27	21.52	60.00	-38.48
10	L1	18.2451	5.47	AVG	10.27	15.74	50.00	-34.26
11	L1	25.6941	17.13	QP	10.41	27.54	60.00	-32.46
12	L1	25.6941	10.64	AVG	10.41	21.05	50.00	-28.95

Test Mode : Bluetooth Mode

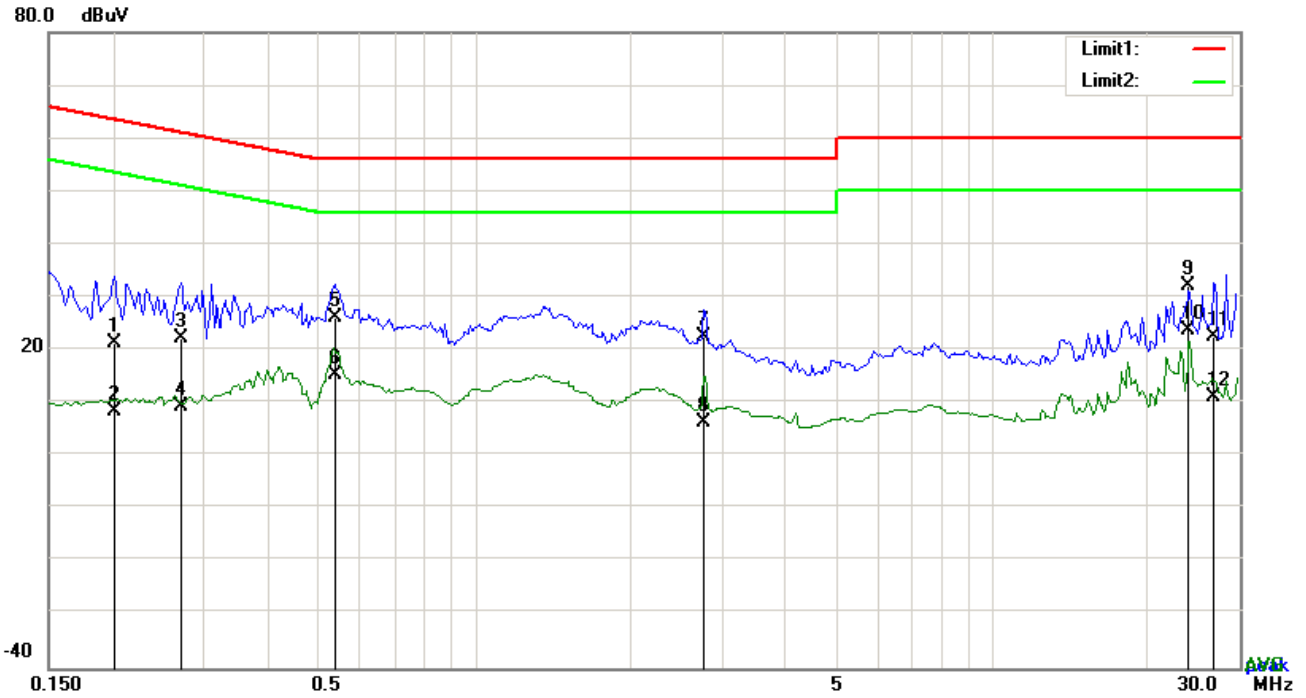

Test Data

Phase Neutral Plot at 240Vac, 60Hz

No.	P/L	Frequency	Reading	Detector	Corrected	Result	Limit	Margin
		(MHz)	(dBuV)		(dB}	(dBuV)	(dBuV)	(dB)
1	N	0.2007	11.47	QP	10.02	21.49	63.58	-42.09
2	N	0.2007	-1.56	AVG	10.02	8.46	53.58	-45.12
3	N	0.2709	12.15	QP	10.02	22.17	61.09	-38.92
4	N	0.2709	-0.66	AVG	10.02	9.36	51.09	-41.73
5	N	0.5361	16.18	QP	10.02	26.20	56.00	-29.80
6	N	0.5361	5.28	AVG	10.02	15.30	46.00	-30.70
7	N	2.7786	12.45	QP	10.05	22.50	56.00	-33.50
8	N	2.7786	-3.65	AVG	10.05	6.40	46.00	-39.60
9	N	24.0015	21.95	QP	10.32	32.27	60.00	-27.73
10	N	24.0015	13.41	AVG	10.32	23.73	50.00	-26.27
11	N	26.8173	12.13	QP	10.37	22.50	60.00	-37.50
12	N	26.8173	0.68	AVG	10.37	11.05	50.00	-38.95

6.9 Radiated Spurious Emissions

Temperature	23°C
Relative Humidity	55%
Atmospheric Pressure	1022mbar
Test date :	June 22, 2016
Tested By :	Loren Luo

Requirement(s):

Spec	Item	Requirement	Applicable										
47CFR§15.205, §15.209, §15.247(d)	a)	<p>Except higher limit as specified elsewhere in other section, the emissions from the low-power radio-frequency devices shall not exceed the field strength levels specified in the following table and the level of any unwanted emissions shall not exceed the level of the fundamental emission. The tighter limit applies at the band edges</p> <table border="1"> <thead> <tr> <th>Frequency range (MHz)</th> <th>Field Strength ($\mu\text{V/m}$)</th> </tr> </thead> <tbody> <tr> <td>30 – 88</td> <td>100</td> </tr> <tr> <td>88 – 216</td> <td>150</td> </tr> <tr> <td>216 960</td> <td>200</td> </tr> <tr> <td>Above 960</td> <td>500</td> </tr> </tbody> </table>	Frequency range (MHz)	Field Strength ($\mu\text{V/m}$)	30 – 88	100	88 – 216	150	216 960	200	Above 960	500	<input checked="" type="checkbox"/>
Frequency range (MHz)	Field Strength ($\mu\text{V/m}$)												
30 – 88	100												
88 – 216	150												
216 960	200												
Above 960	500												

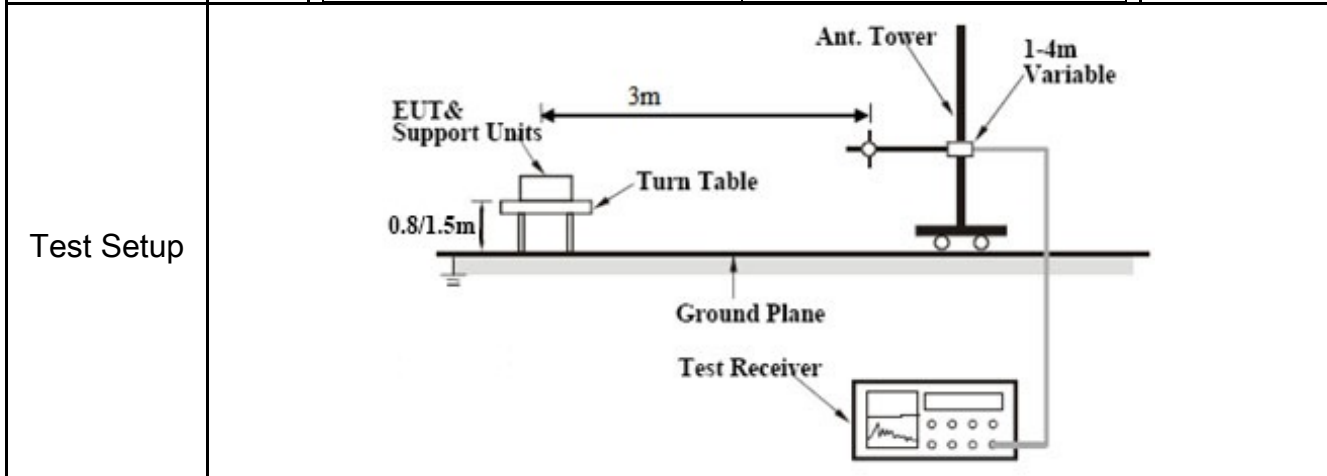

Procedure	<ol style="list-style-type: none"> The EUT was switched on and allowed to warm up to its normal operating condition. The test was carried out at the selected frequency points obtained from the EUT characterization. Maximization of the emissions, was carried out by rotating the EUT, changing the antenna polarization, and adjusting the antenna height in the following manner:
-----------	---

Test Report	16070642-FCC-R
Page	42 of 57

	<p>a. Vertical or horizontal polarization (whichever gave the higher emission level over a full rotation of the EUT) was chosen.</p> <p>b. The EUT was then rotated to the direction that gave the maximum emission.</p> <p>c. Finally, the antenna height was adjusted to the height that gave the maximum emission.</p> <p>3. The resolution bandwidth and video bandwidth of test receiver/spectrum analyzer is 120 kHz for Quasiy Peak detection at frequency below 1GHz.</p> <p>4. The resolution bandwidth of test receiver/spectrum analyzer is 1MHz and video bandwidth is 3MHz with Peak detection for Peak measurement at frequency above 1GHz. The resolution bandwidth of test receiver/spectrum analyzer is 1MHz and the video bandwidth is 10Hz with Peak detection for Average Measurement as below at frequency above 1GHz.</p> <p>5. Steps 2 and 3 were repeated for the next frequency point, until all selected frequency points were measured.</p>
Remark	
Result	<input checked="" type="checkbox"/> Pass <input type="checkbox"/> Fail

Test Data Yes N/A

Test Plot Yes (See below) N/A

Test Mode: Bluetooth Mode

Below 1GHz

80.0 dBuV/m

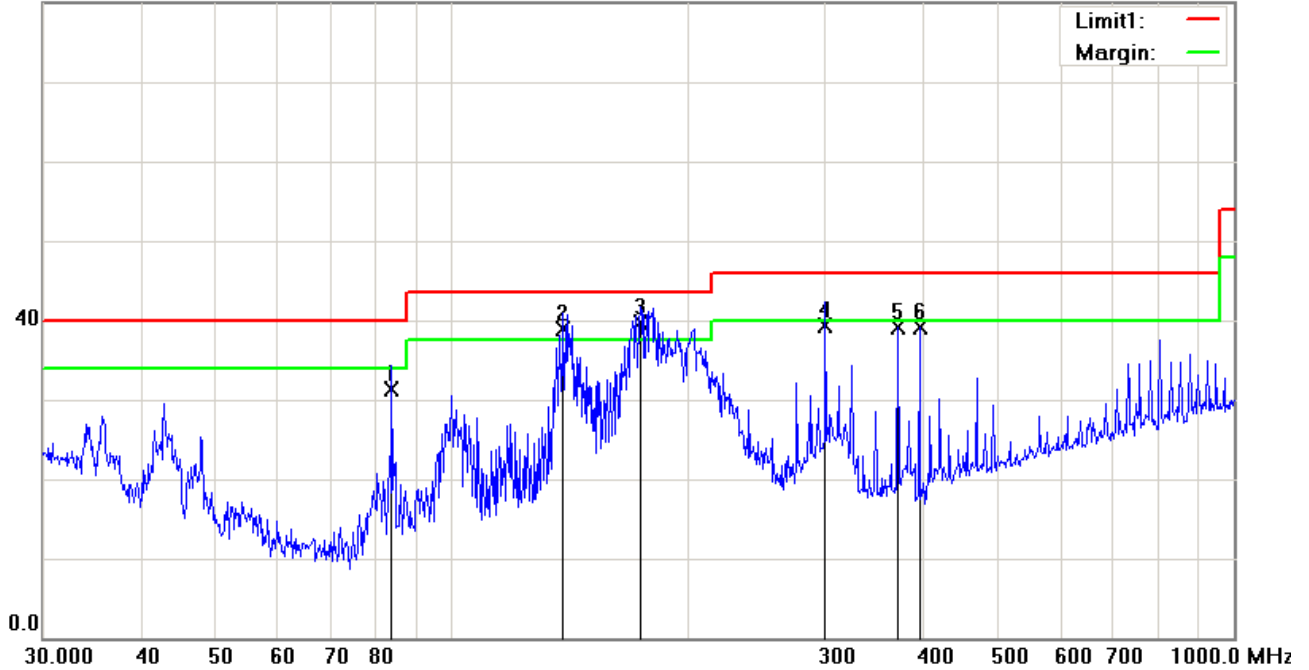

Test Data

Horizontal Polarity Plot @3m

No.	P/L	Frequency (MHz)	Reading (dBuV/m)	Detector	Corrected (dB/m)	Result (dBuV/m)	Limit (dBuV/m)	Margin (dB)	Height (cm)	Degree (°)
1	H	83.8156	44.84	QP	-13.56	31.28	40.00	-8.72	100	258
2	H	138.8735	47.31	QP	-8.48	38.83	43.50	-4.67	100	111
3	H	174.4241	49.23	QP	-9.45	39.78	43.50	-3.72	100	0
4	H	300.3673	46.26	QP	-6.89	39.37	46.00	-6.63	100	6
5	H	372.0045	44.14	peak	-4.95	39.19	46.00	-6.81	100	183
6	H	396.2415	43.54	peak	-4.39	39.15	46.00	-6.85	100	325

Below 1GHz

80.0 dBuV/m

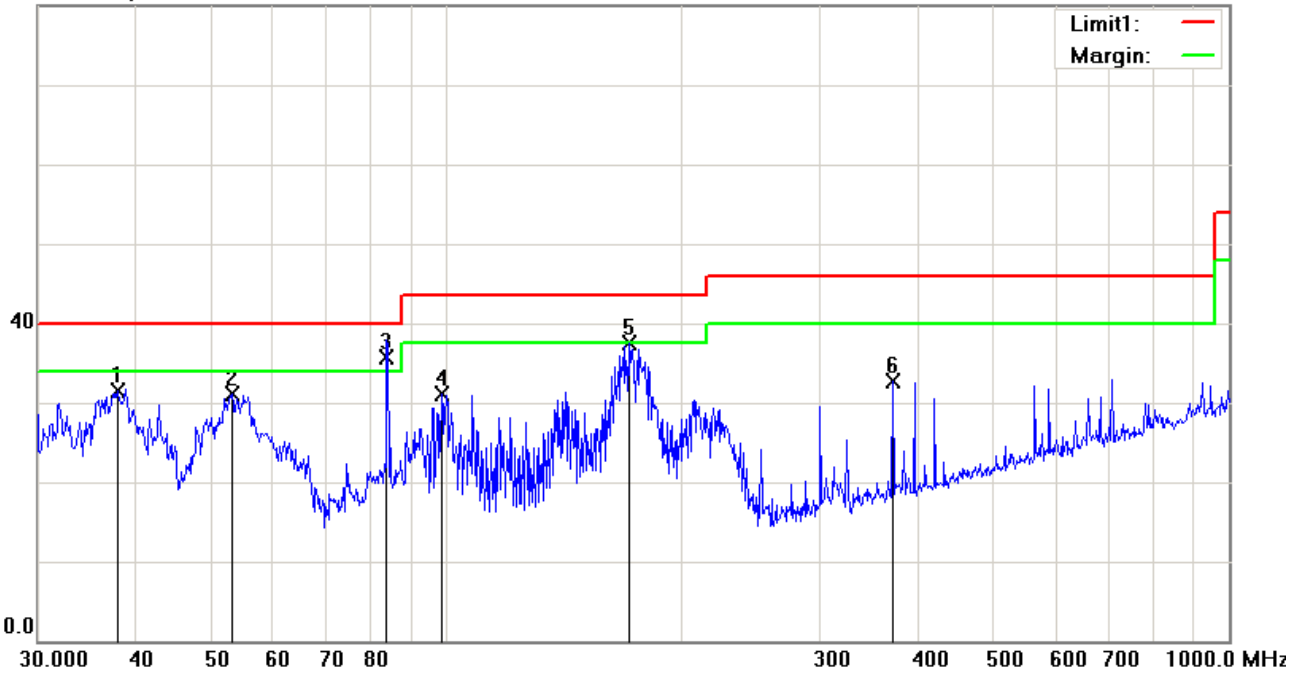

Test Data

Vertical Polarity Plot @3m

No.	P/L	Frequency (MHz)	Reading (dBuV/m)	Detector	Corrected (dB/m)	Result (dBuV/m)	Limit (dBuV/m)	Margin (dB)	Height (cm)	Degree (°)
1	V	37.9450	37.59	peak	-6.09	31.50	40.00	-8.50	100	41
2	V	53.1313	44.72	peak	-13.54	31.18	40.00	-8.82	100	319
3	V	83.8156	49.36	QP	-13.56	35.80	40.00	-4.20	100	30
4	V	98.4866	42.25	peak	-11.20	31.05	43.50	-12.45	100	240
5	V	170.7926	46.60	peak	-9.16	37.44	43.50	-6.06	100	79
6	V	372.0045	37.74	peak	-4.95	32.79	46.00	-13.21	100	60

Test Mode:	Transmitting Mode
-------------------	--------------------------

Low Channel: GFSK Mode (Worst Case) (2402 MHz)

Frequency (MHz)	S.A. Reading (dBμV)	Detector (PK/AV)	Polarity (H/V)	Ant. Factor (dB/m)	Cable Loss (dB)	Pre-Amp. Gain (dB)	Cord. Amp. (dBμV/m)	Limit (dBμV/m)	Margin (dB)
4804	38.66	AV	V	33.67	6.86	32.66	46.53	54	-7.47
4804	38.51	AV	H	33.67	6.86	32.66	46.38	54	-7.62
4804	47.95	PK	V	33.67	6.86	32.66	55.82	74	-18.18
4804	47.38	PK	H	33.67	6.86	32.66	55.25	74	-18.75
17793	24.53	AV	V	44.76	11.26	31.89	48.66	54	-5.34
17793	24.29	AV	H	44.76	11.26	31.89	48.42	54	-5.58
17793	40.91	PK	V	44.76	11.26	31.89	65.04	74	-8.96
17793	40.65	PK	H	44.76	11.26	31.89	64.78	74	-9.22

Middle Channel: π /4 DQPSK Mode (Worst Case) (2441 MHz)

Frequency (MHz)	S.A. Reading (dBμV)	Detector (PK/AV)	Polarity (H/V)	Ant. Factor (dB/m)	Cable Loss (dB)	Pre-Amp. Gain (dB)	Cord. Amp. (dBμV/m)	Limit (dBμV/m)	Margin (dB)
4882	38.75	AV	V	33.71	6.95	32.74	46.67	54	-7.33
4882	38.63	AV	H	33.71	6.95	32.74	46.55	54	-7.45
4882	48.01	PK	V	33.71	6.95	32.74	55.93	74	-18.07
4882	47.67	PK	H	33.71	6.95	32.74	55.59	74	-18.41
17807	24.16	AV	V	44.82	11.35	31.94	48.39	54	-5.61
17807	24.02	AV	H	44.82	11.35	31.94	48.25	54	-5.75
17807	41.25	PK	V	44.82	11.35	31.94	65.48	74	-8.52
17807	40.79	PK	H	44.82	11.35	31.94	65.02	74	-8.98

High Channel: GFSK Mode (Worst Case) (2480 MHz)

Frequency (MHz)	S.A. Reading (dB μ V)	Detector (PK/AV)	Polarity (H/V)	Ant. Factor (dB/m)	Cable Loss (dB)	Pre-Amp. Gain (dB)	Cord. Amp. (dB μ V/m)	Limit (dB μ V/m)	Margin (dB)
4960	38.59	AV	V	33.9	6.76	32.74	46.51	54	-7.49
4960	38.46	AV	H	33.9	6.76	32.74	46.38	54	-7.62
4960	48.12	PK	V	33.9	6.76	32.74	56.04	74	-17.96
4960	47.95	PK	H	33.9	6.76	32.74	55.87	74	-18.13
17815	24.72	AV	V	44.85	11.35	31.89	49.03	54	-4.97
17815	24.48	AV	H	44.85	11.35	31.89	48.79	54	-5.21
17815	41.35	PK	V	44.85	11.35	31.89	65.66	74	-8.34
17815	41.09	PK	H	44.85	11.35	31.89	65.4	74	-8.6

Note:

- 1, The testing has been conformed to $10 \times 2480 \text{ MHz} = 24,800 \text{ MHz}$
- 2, All other emissions more than 30 dB below the limit
- 3, X-Axis, Y-Axis and Z-Axis were investigated. The results above show only the worst case.

Annex A. TEST INSTRUMENT

Instrument	Model	Serial #	Cal Date	Cal Due	In use
AC Line Conducted					
EMI test receiver	ESCS30	8471241027	09/17/2015	09/16/2016	<input checked="" type="checkbox"/>
Line Impedance	LI-125A	191106	09/25/2015	09/24/2016	<input checked="" type="checkbox"/>
Line Impedance	LI-125A	191107	09/25/2015	09/24/2016	<input checked="" type="checkbox"/>
LISN	ISN T800	34373	09/25/2015	09/24/2016	<input checked="" type="checkbox"/>
Double Ridge Horn Antenna (1 ~18GHz)	AH-118	71283	09/24/2015	09/23/2016	<input checked="" type="checkbox"/>
Transient Limiter	LIT-153	531118	09/01/2015	08/31/2016	<input checked="" type="checkbox"/>
RF conducted test					
Agilent ESA-E SERIES	E4407B	MY45108319	09/17/2015	09/16/2016	<input checked="" type="checkbox"/>
Power Splitter	1#	1#	09/01/2015	08/31/2016	<input checked="" type="checkbox"/>
DC Power Supply	E3640A	MY40004013	09/17/2015	09/16/2016	<input checked="" type="checkbox"/>
Radiated Emissions					
EMI test receiver	ESL6	100262	09/17/2015	09/16/2016	<input checked="" type="checkbox"/>
Positioning Controller	UC3000	MF780208282	11/19/2015	11/18/2016	<input checked="" type="checkbox"/>
OPT 010 AMPLIFIER (0.1-1300MHz)	8447E	2727A02430	09/01/2015	08/31/2016	<input checked="" type="checkbox"/>
Microwave Preamplifier (1 ~ 26.5GHz)	8449B	3008A02402	03/24/2016	03/23/2017	<input checked="" type="checkbox"/>
Bilog Antenna (30MHz~6GHz)	JB6	A110712	09/21/2015	09/20/2016	<input checked="" type="checkbox"/>
Double Ridge Horn Antenna (1 ~18GHz)	AH-118	71283	09/24/2015	09/23/2016	<input checked="" type="checkbox"/>
Universal Radio Communication Tester	CMU200	121393	09/25/2015	09/24/2016	<input checked="" type="checkbox"/>

Annex B. EUT And Test Setup Photographs

Annex B.i. Photograph: EUT External Photo

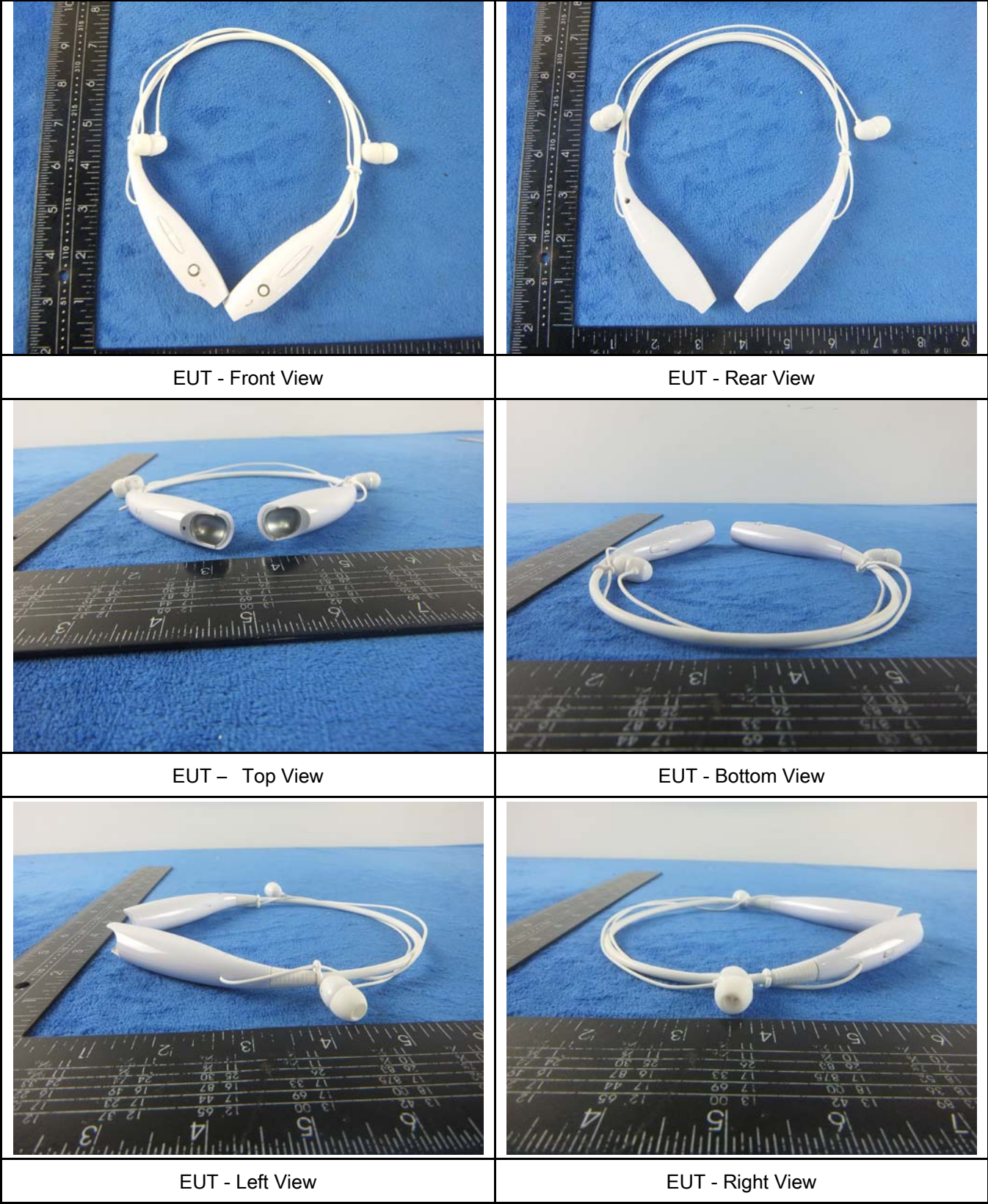

Annex B.ii. Photograph: EUT Internal Photo



Cover Off - Top View

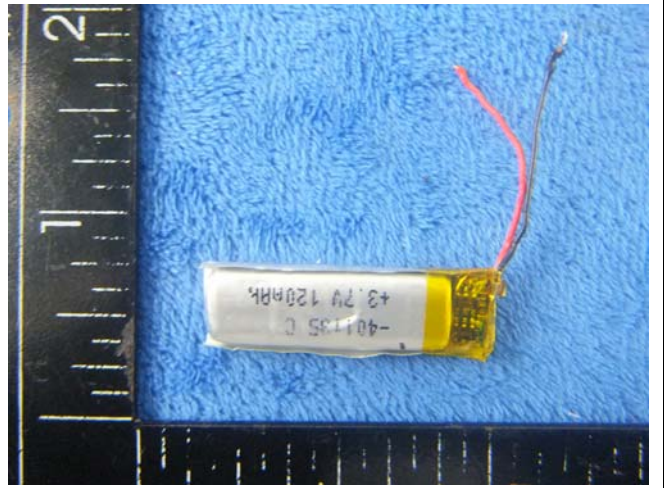

Battery - Front View

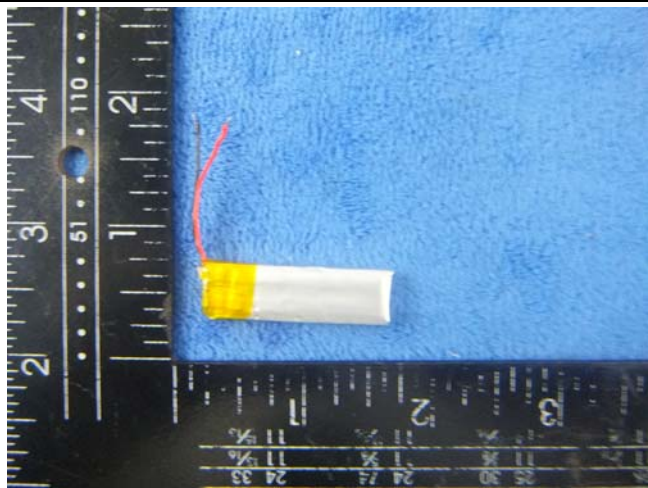

Battery - Rear View

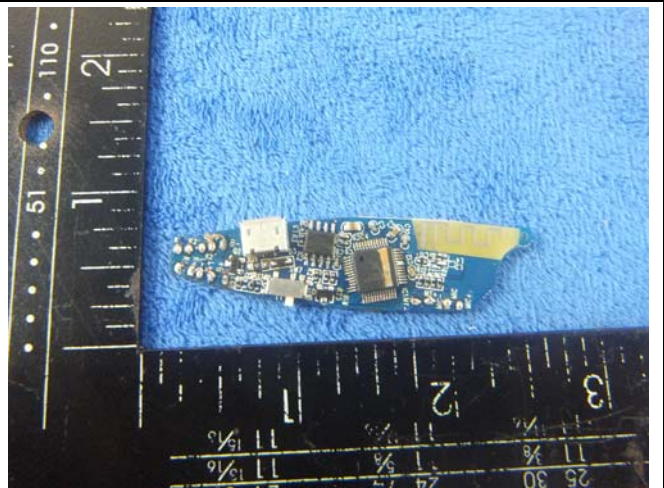

Mainboard 1- Front View

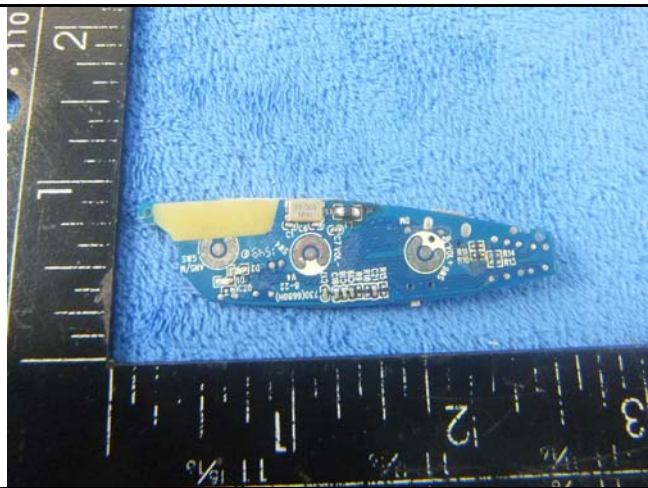

Mainboard 1- Rear View

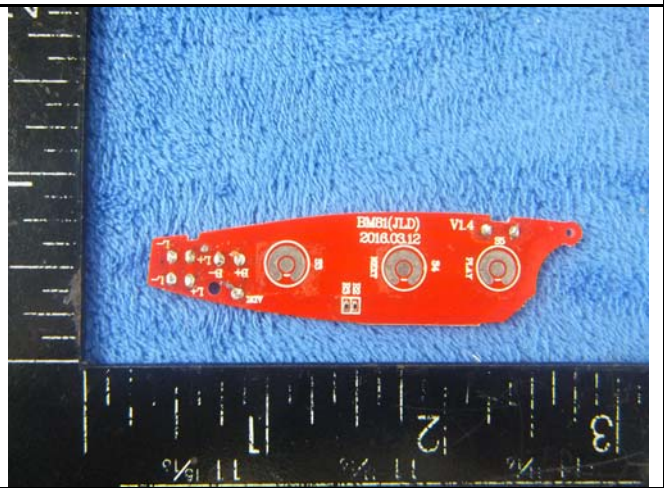

Mainboard 2- Front View



Mainbord 2- Rear View

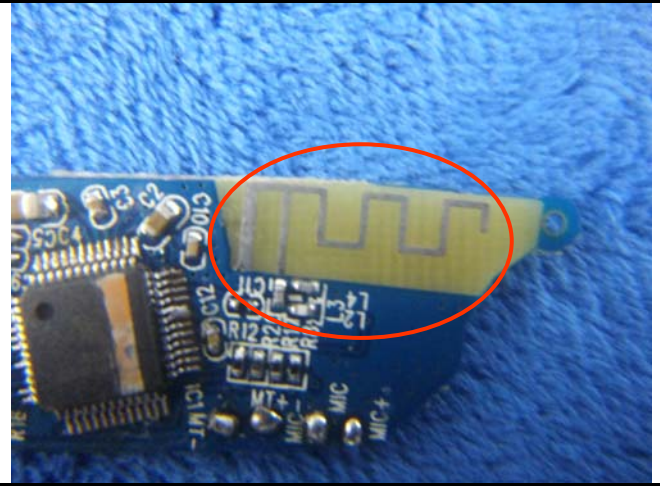

BT - Antenna View

Annex B.iii. Photograph: Test Setup Photo



Conducted Emissions Test Setup – Front View



Conducted Emissions Test Setup – Side View

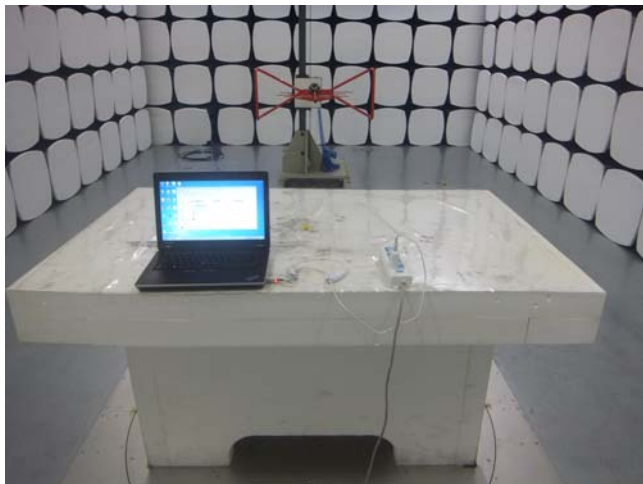

Radiated Spurious Emissions Test Setup Below 1GHz

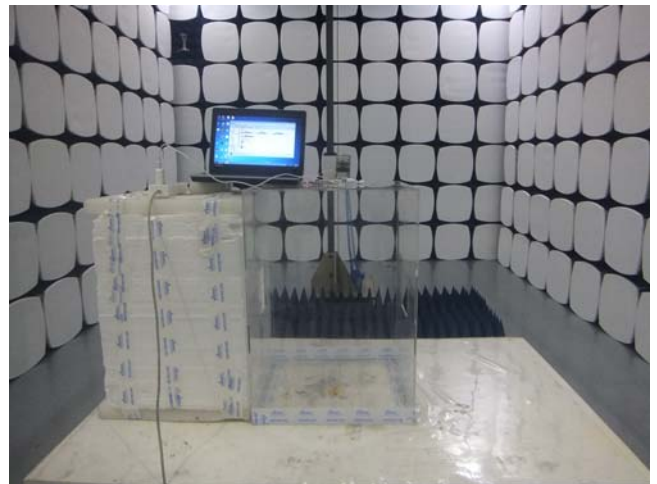

Radiated Spurious Emissions Test Above 1GHz



Radiated Spurious Emissions Test Above 1GHz

Annex C. TEST SETUP AND SUPPORTING EQUIPMENT

Annex C.ii. TEST SET UP BLOCK

Block Configuration Diagram for AC Line Conducted Emissions

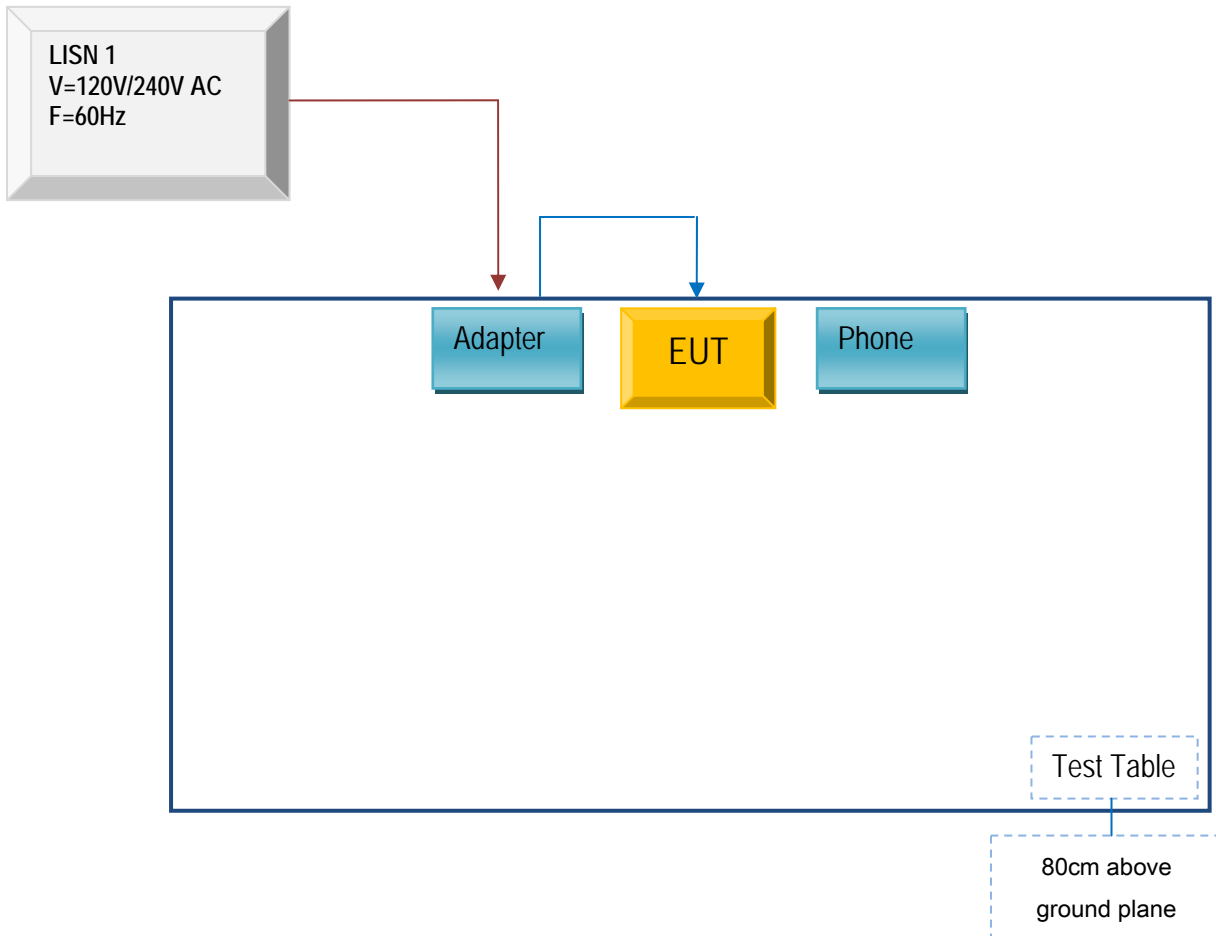

Block Configuration Diagram for Radiated Emission (Below 1GHz) .

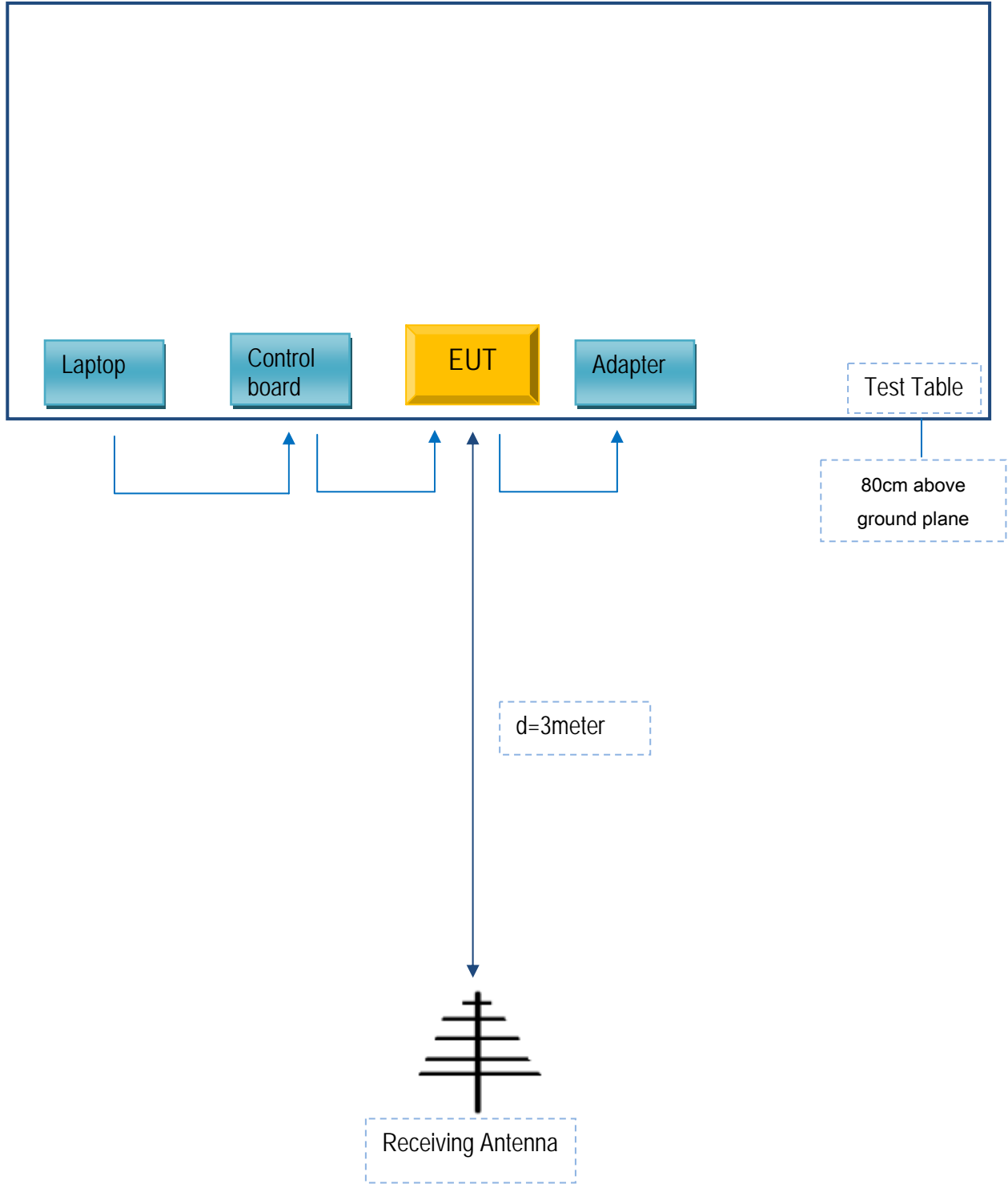

Block Configuration Diagram for Radiated Emission (Above 1GHz) .

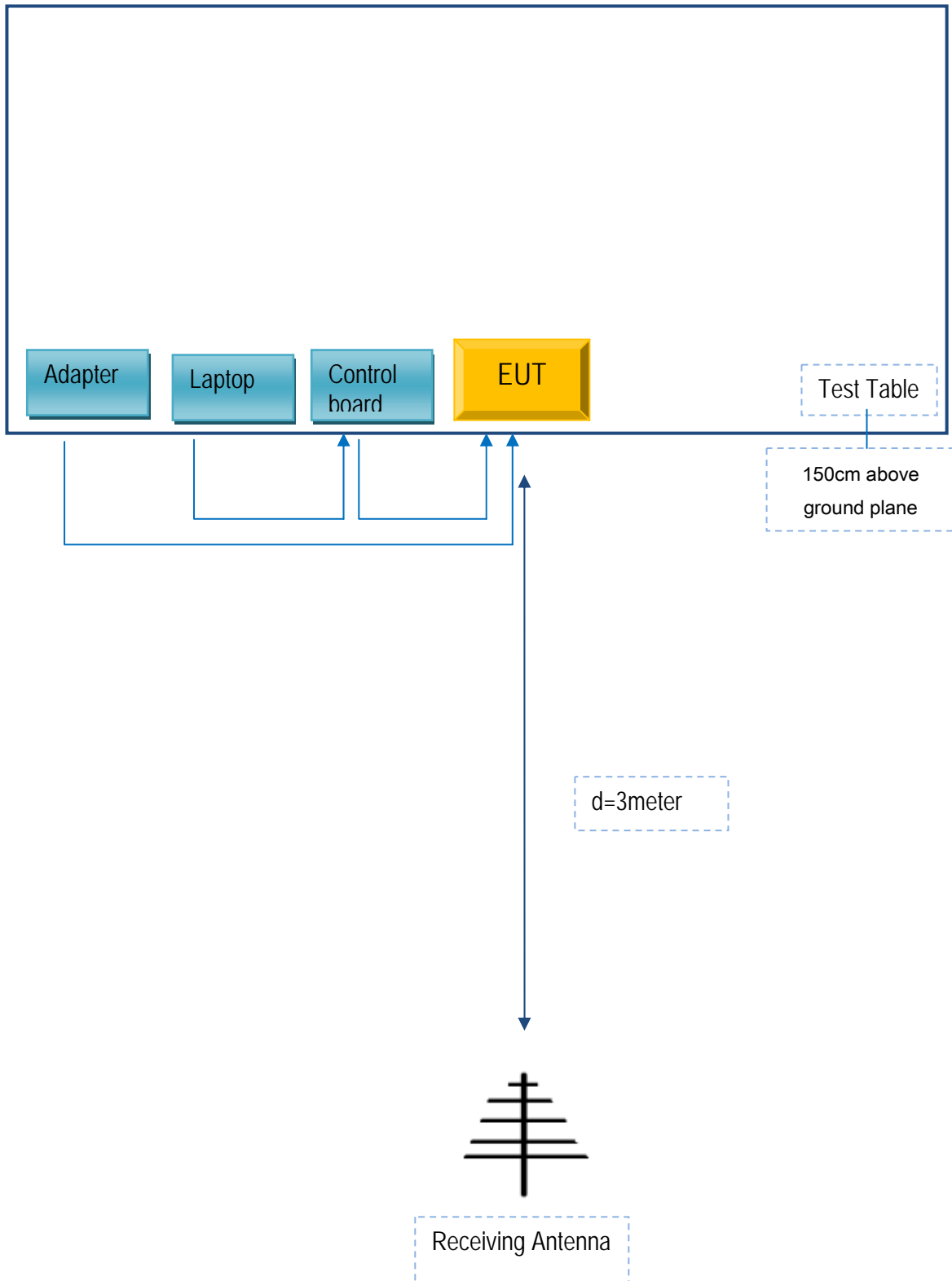

Annex C. ii. SUPPORTING EQUIPMENT DESCRIPTION

The following is a description of supporting equipment and details of cables used with the EUT.

Supporting Equipment:

Manufacturer	Equipment Description	Model	Serial No
Lenovo	Lenovo Laptop	E40	N3-F5022
MI	Phone	MI 4W	W01400
Lenovo	Adapter	DX-13250	C10503

Supporting Cable:

Cable type	Shield Type	Ferrite Core	Length	Serial No
USB Cable	Un-shielding	No	0.5m	Hk10023

Test Report	16070642-FCC-R
Page	56 of 57

Annex D. User Manual / Block Diagram / Schematics / Partlist

N/A

Annex E. DECLARATION OF SIMILARITY

DongGuan TuoXiang Electronics Technology Co.,Ltd

To: 775 Montague Expressway Milpitas, CA 95035, USA

Declaration Letter

For our business issue and marketing requirement, we would like to list 18 models on the FCC reports, as following:

We declare that :

Main Model No	Serial Model No	Difference
HBS-730	HBS-730TF HBS-770TF HV-800 HBS-730S HBS-770, HBS-760S HBS-530 HBS-580 HBS-600 HBS-650 HBS-660 HBS-860 HBS-880 HBS-930 HBS-950 HBS-960 HBS-980	The PCB and appearance ,shape of these models are the same, the differences are: Color, model names and material of the enclosure, part of the several models ' enclosure are normal plastic, others are ceramoplastic.

Thank you!

Sincerely,

Client's signature:



Client's name / title: Manager

Contact information / address :

Fifth Floor, Building 1E,HongDa Industrial Zone JianShe Road ,ShiMa village ,DongGuan ,GuangDong Province ,China.