



Pro Sensor Models M1017--- (Propane)

INTENDED USE OF THE M1017 SENSOR IS TO MEASURE THE AMOUNT OF LIQUID PROPANE INSIDE A PROPANE TANK MEETING THE SPECIFICATIONS BELOW, UNDER THE CONDITIONS LISTED BELOW.

THIS DEVICE IS INTENDED FOR OUTDOOR USE ONLY.

WARNING

USE OF THIS DEVICE IN A MANNER OTHER THAN STATED IN THIS MANUAL, MAY RESULT IN IMPAIRMENT OF THE DESIGNED SAFETY PROTECTION AND THUS AN UNSAFE CONDITION.

SPECIFICATIONS	
MEASUREMENT METHOD	Ultrasonic
FLUID	Propane
TANK TYPES	Steel or Aluminum Not intended for use on composite cylinders.
TANK SIZES	Horizontal and Vertical Tanks Up to 48-inch fluid height
Envelope Dimensions	73 mm Diameter x 7.3 mm Thickness (2.87 x 0.29 inches)
Mounting location	Tank Bottom Steel Tanks use magnet version Aluminum tanks require collars attached with pre-applied adhesive Other mount devices also available
Suitable for these locations	CLASS I, DIVISION 2, GROUP D CLASS I, ZONE 2, GROUP IIA
OPERATING TEMPERATURE RANGE	-30° TO 55°C
TEMPERATURE CODE	T6
BATTERY	ONE, CR2032 COIN CELL (3V)
HUMIDITY RANGE	0 - 100%
MAX ALTITUDE	4000m

WARNING

EXPLOSION HAZARD-BATTERIES MUST ONLY BE CHANGED IN AN AREA FREE OF IGNITIBLE CONCENTRATIONS.

WARNING

THIS DEVICE IS NOT TO BE REPAIRED OR OTHERWISE MODIFIED.

MOPEKA PRODUCTS LLC
MAILING ADDRESS: 445 FM 1983, COLORADO CITY, TX 79512
www.mopeka.com
support@mopeka.com



OPERATING INSTRUCTIONS

Smart Device/App Users

1. Go to your app store. Search for Mopeka Tank Check app and install.
2. Launch the app. When it starts it will automatically start a search for Mopeka ✓ sensors.

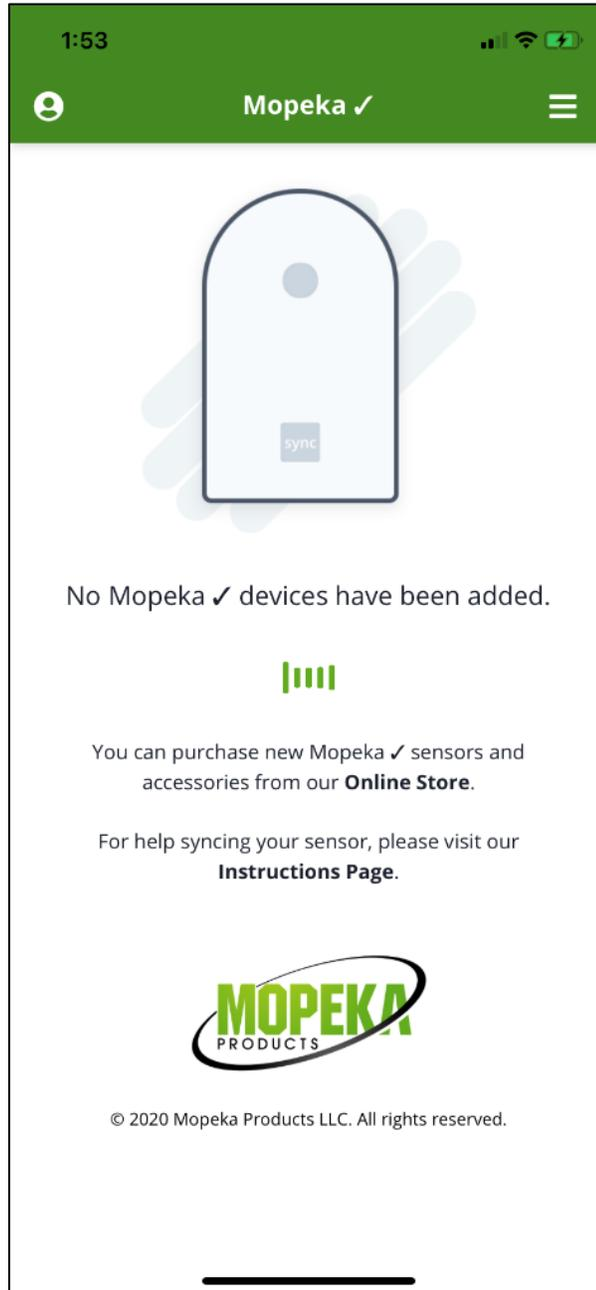

3. Press and hold SYNC button until sensor appears on app. (up to 10 seconds)

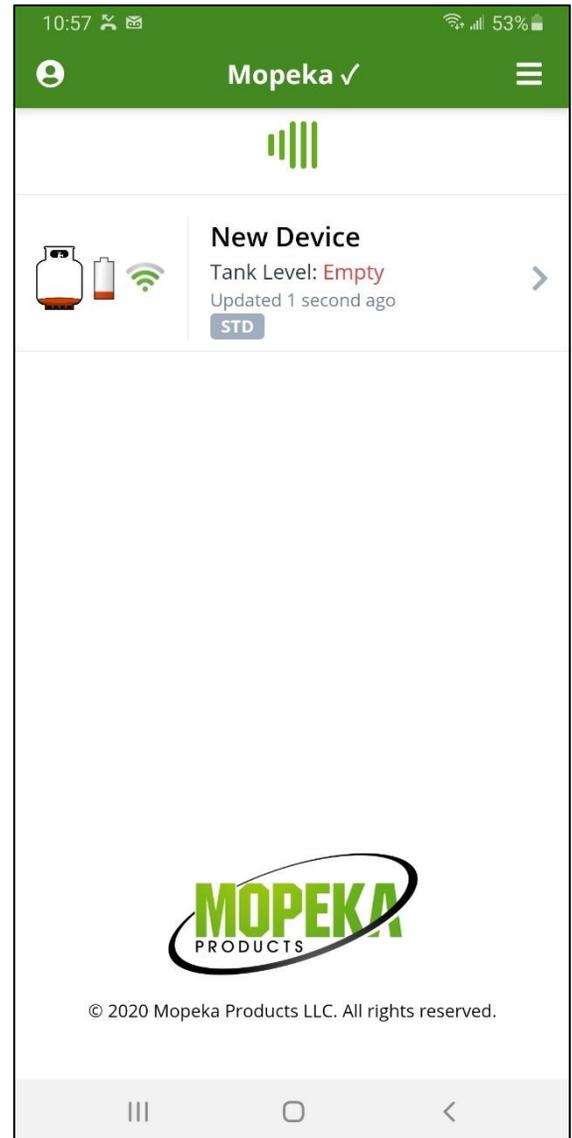
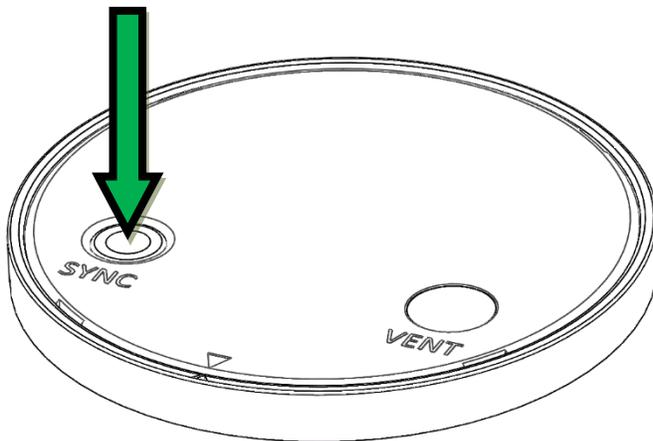

4. The sensor will then appear on your app as a new device.
5. Sensor is now Sync'd. You may now proceed to installing the sensor on the tank.

For LPG Tank ✓ Display Users:

6. Pull the battery protection strip completely out of display and discard. This will turn on the display.

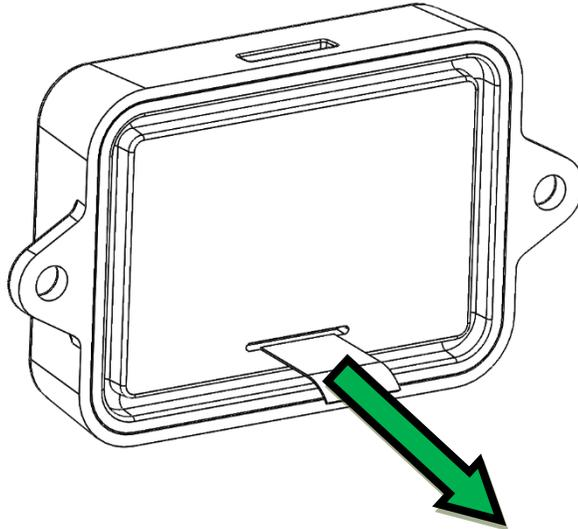

7. Hold one of the buttons on your Display until the lights for that button start flashing (approx 5 seconds). Release button when lights start flashing.
8. Press and hold SYNC button until sensor (up to 10 seconds) until the display lights stop flashing. The sensor is now synced with the display.
9. Repeat steps to sync the second sensor to the 2nd button/gauge of the display.
10. Both sensors are now sync'd to the display.
11. The display is programmable, allowing you to choose a tank size of 20 lb (5 gal), 30 lb (7.5 gal), or 40 lb (10 gal).
12. It is automatically set to 20 lb from the factory. To change the size setting, hold the button of the scale you want to change for 10 seconds. (After 5 seconds lights will start flashing, as when syncing. But continue to hold button until lights change again.)
13. At 10 seconds, a single light will appear. Continue to hold button. The single light will scroll between red, yellow, and green. When the color corresponding to your tank size appears, release the button. Your tank size is now set.
 - Red = 20 lb
 - Yellow = 30 lb
 - Green = 40 lb
14. You are now ready to install the sensor(s) on the tank(s).

Install Sensor on Tank-Vertical Cylinders

15. Clean the bottom of the tank of any debris, excess paint, and rust.
16. If your tank sits directly on the ground or other flat surface, then install the spacers to the bottom of the foot ring of your tank. This will provide adequate space and improved wireless range for the sensor.

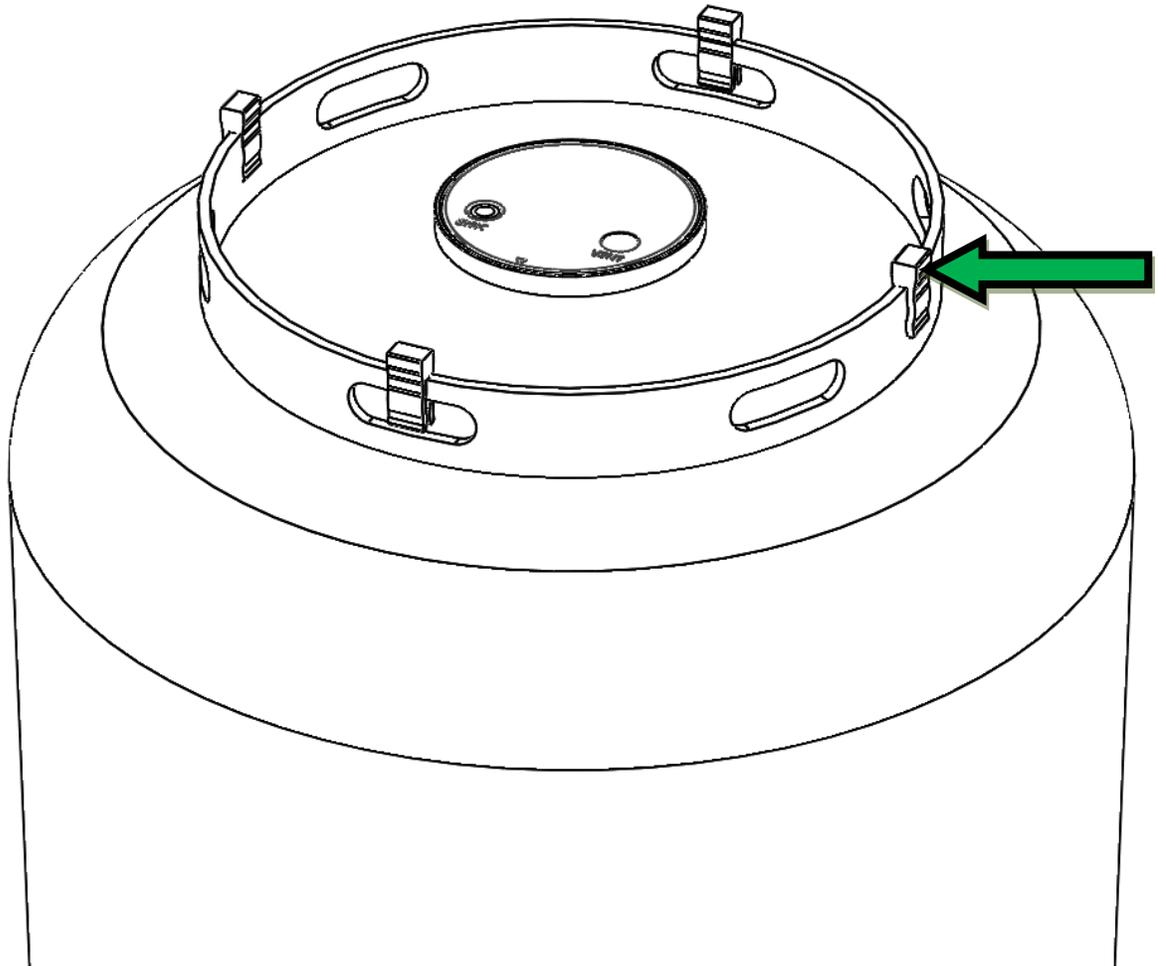

Steel Tanks:

17. The sensor mounts to the bottom center of the tank using magnets. The rubber pad between the magnets must make good contact with the tank, with no contaminants in between and must be aligned to the bottom center of the tank.
18. Apply a generous amount of the supplied sonic grease directly to the rubber pad before attaching sensor to the tank.
19. Install sensor on tank such that rubber pad is aligned with the bottom, center of tank.

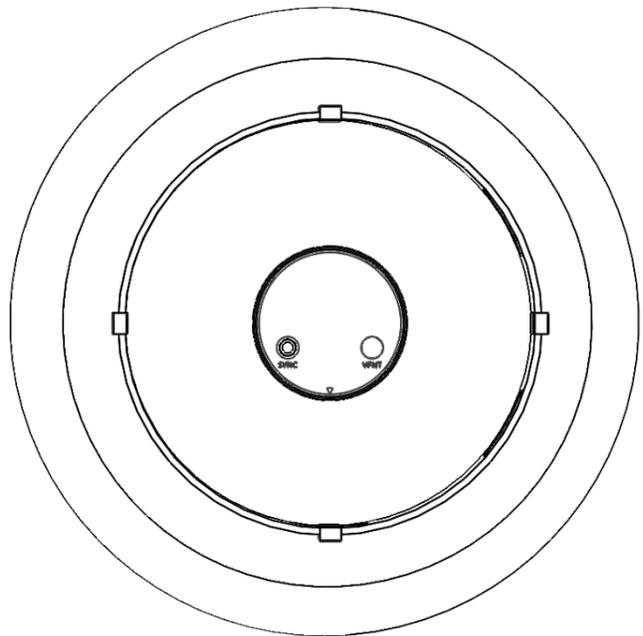
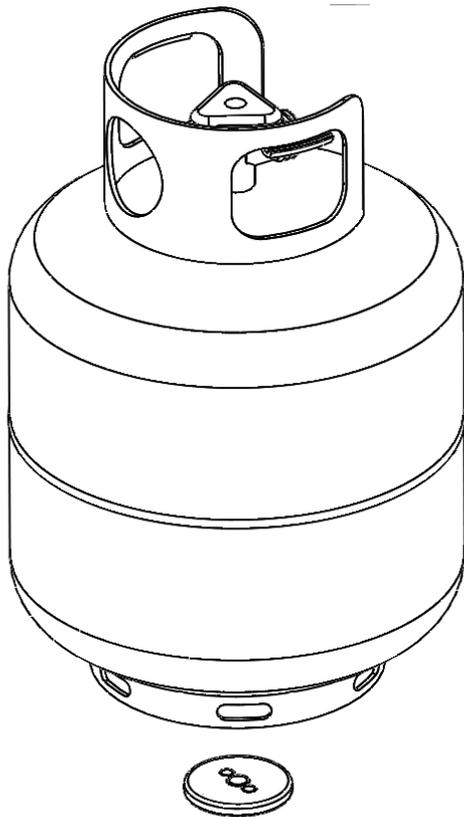
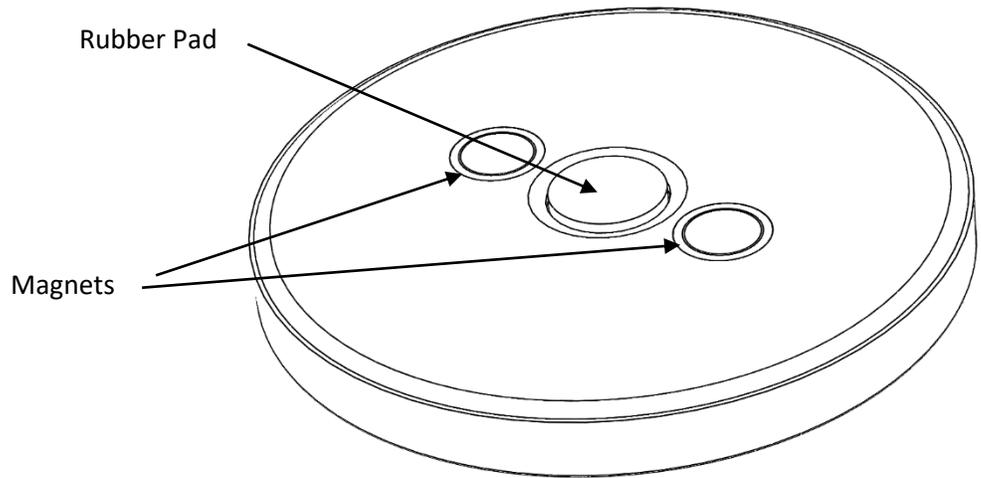

Aluminum Tanks:

20. The sensor mounts to the bottom center of the tank using the collar set.
21. The collar set has pre-applied 2-sided adhesive. **The tank must be properly prepared or the collar will not adhere.**
22. **The tank must be thoroughly cleaned with soap and water.**
23. **Allow the water to dry, then clean the tank with an alcohol pad or similar, to remove all grease.**
24. Lay the collar set in the center of the tank bottom, and mark as needed to guide the final installation of the collar onto the tank.
25. Separate the collar pieces, peel the backing paper from the base piece, and stick to the tank per your markings. **Thoroughly press the ring all the way around. Pressure is required to force the tape to adhere to the tank.**
26. Apply a generous amount of the supplied sonic grease directly to the rubber pad before attaching sensor to the tank.
27. Install sensor inside the collar, rubber pad against tank.
28. Now snap the retaining ring onto the collar set.

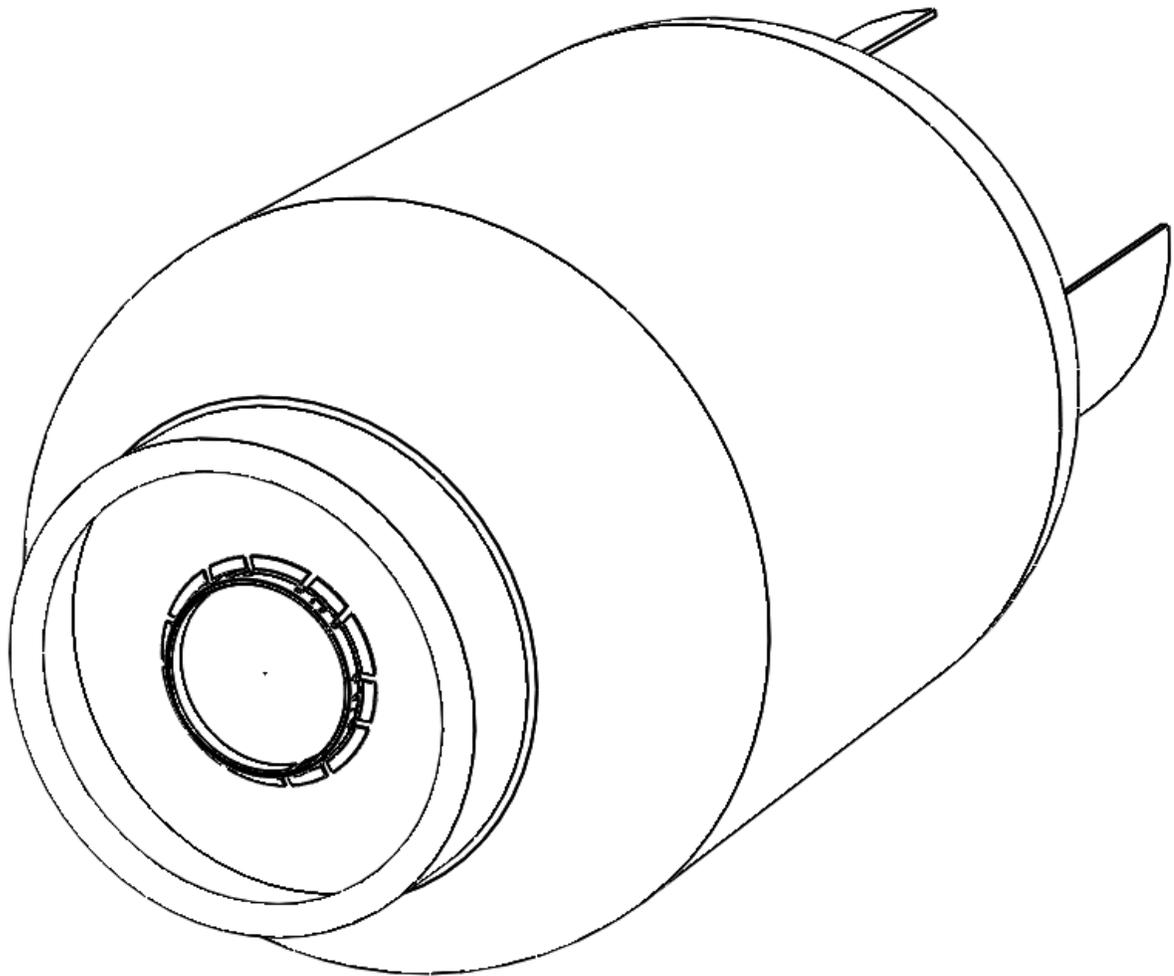

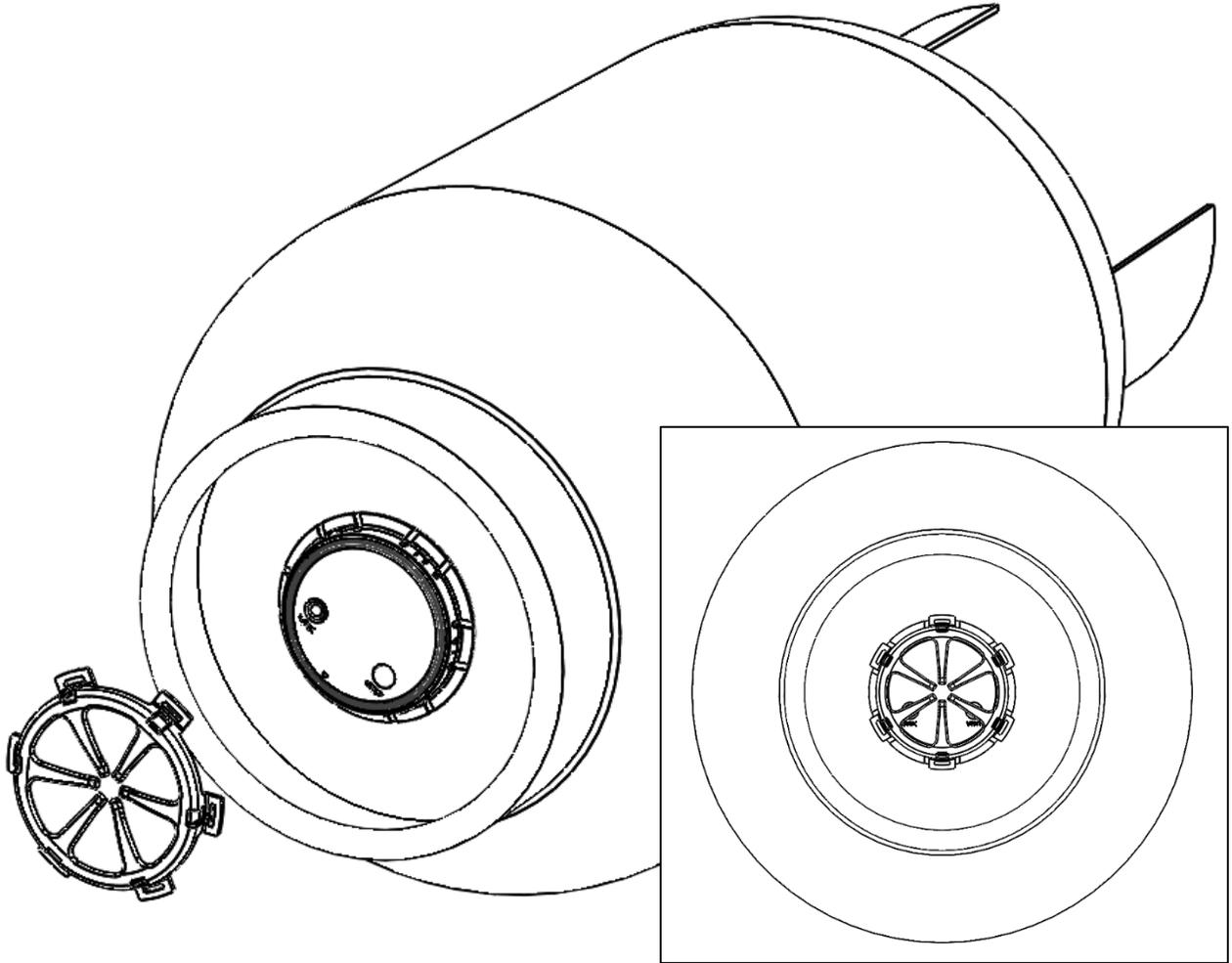

29. Return the tank to the upright position. Check that the tank is on a level and flat surface or otherwise is level with ground. A tilt can degrade the quality of the measurement.
30. After a few seconds, up to a few minutes, the propane will settle, and the readings will stabilize.

Install Sensor on Tank-Horizontal Cylinders

31. If installing on a horizontal tank, place the sensor on center, bottom of tank, with rubber pad and magnets against tank as shown. It is important to place it on the center of tank so that sensor is horizontal, or sensor reading quality can be poor.

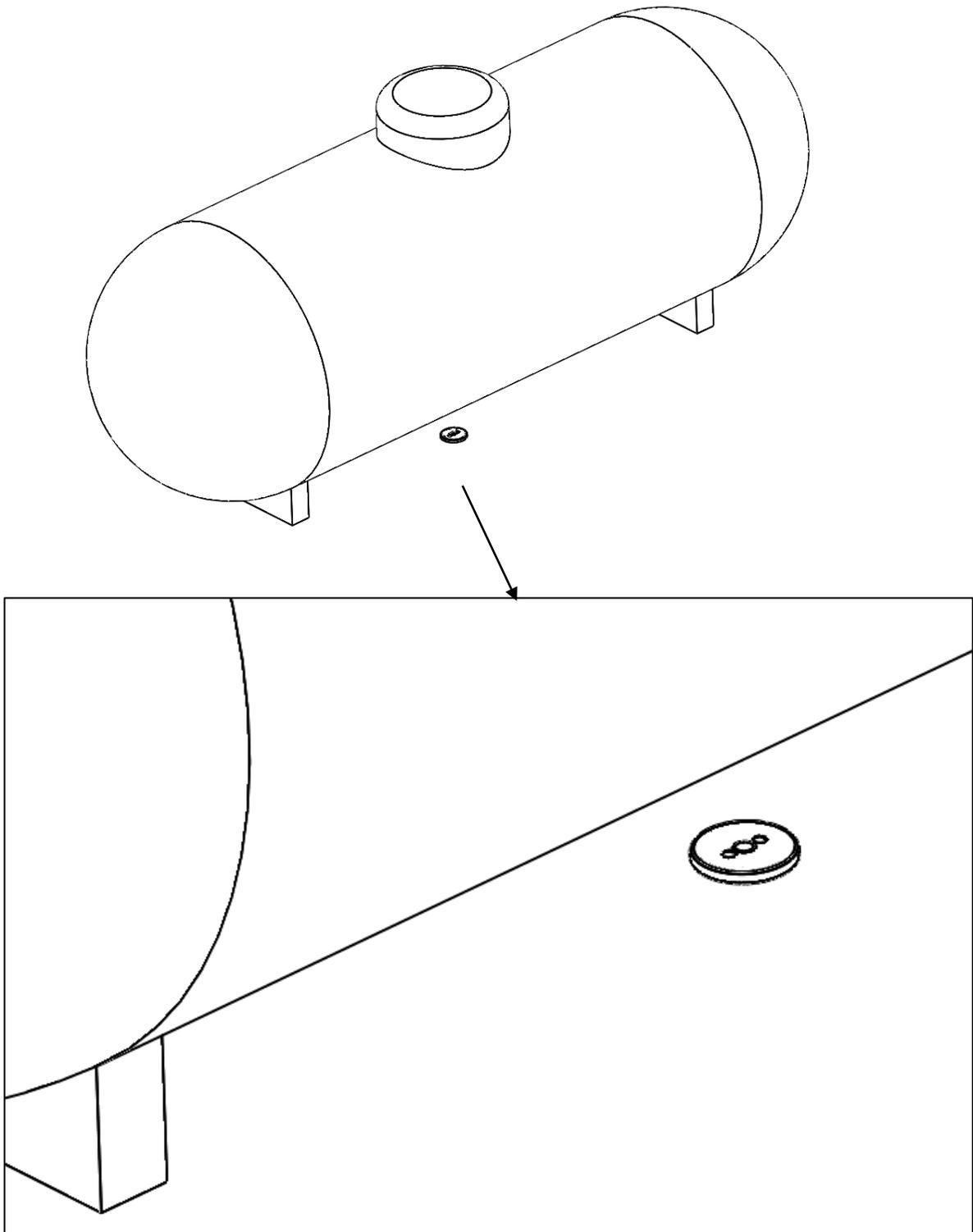

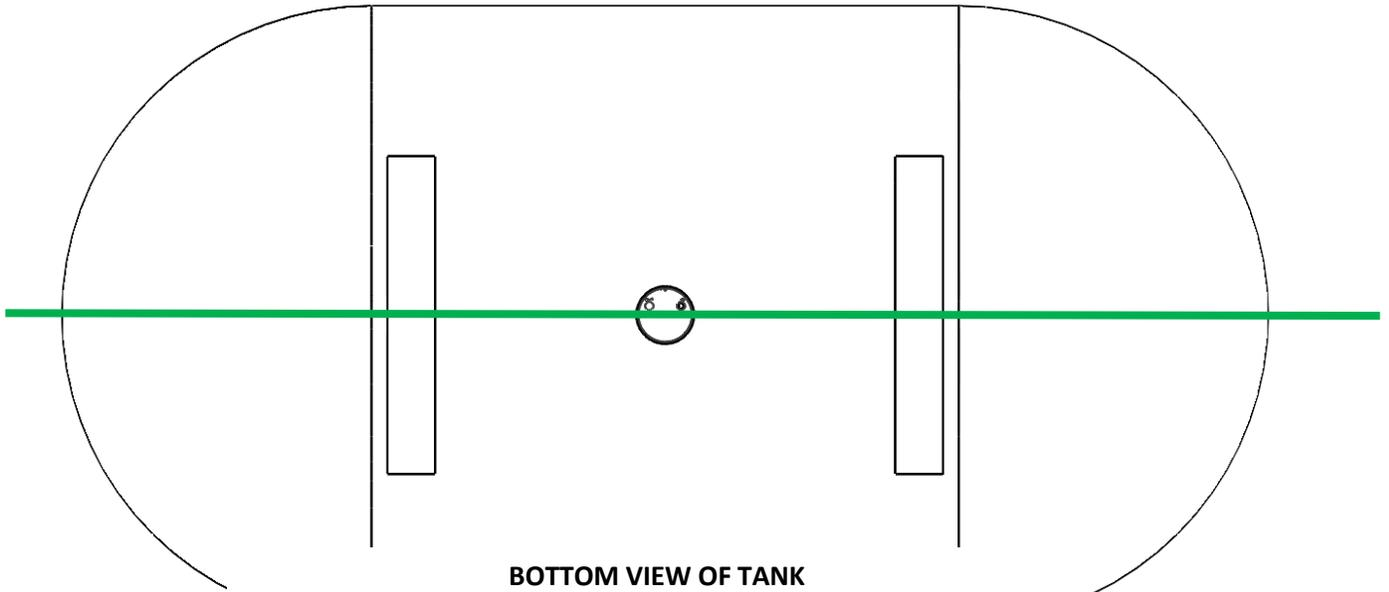

BOTTOM VIEW OF TANK
 (Green line is centerline of tank. Magnets and rubber pad should all be on tank centerline.)

32. Use the Sensor Position option on the sensor's home page in the app, as needed, to ensure proper position on the tank. When installed correctly, the sensor will be level to the horizon. The Sensor Position tool works like a bubble level. The dots move as the sensor is tilted from horizontal level position. If the dots in the tool do not line up to the center of the graphic, adjust the sensor position until it lines up. **Note: If sensor must be repositioned multiple times, sonic grease may need to be reapplied.**

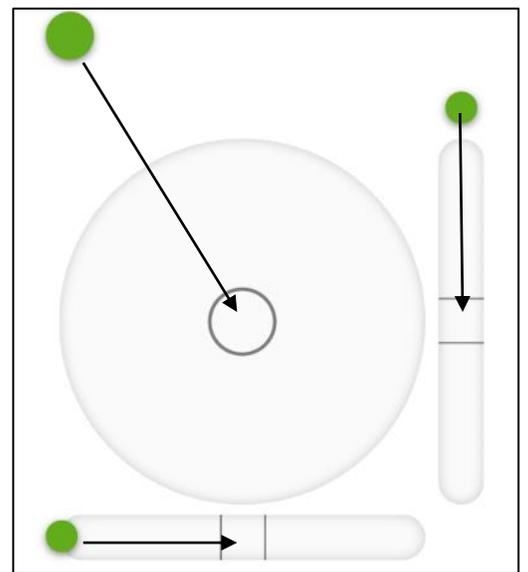
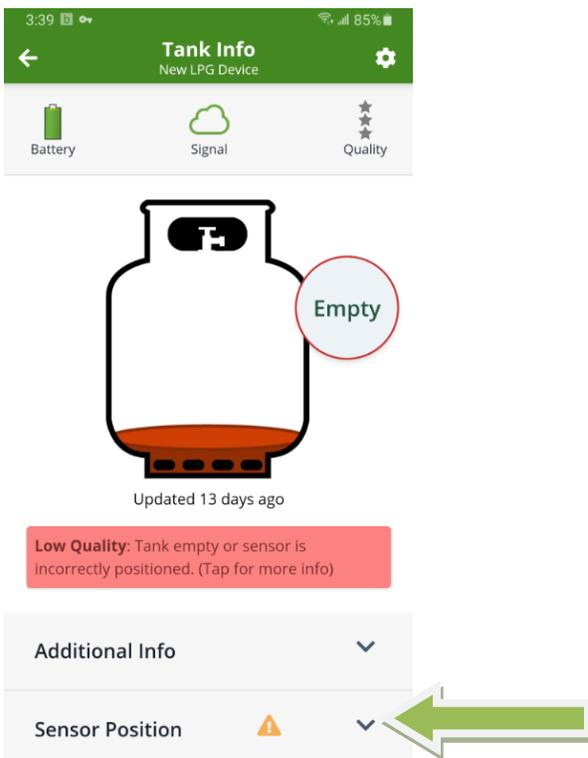



Using the LPG Tank ✓

App Users:

33. Clicking on a sensor in the main list takes you to the sensor's own screen, where you can change settings specific to that sensor. Click on the settings icon to modify. Common items to check are-
 - a. Check the tank size to match your tank.
 - b. Rename the sensor as needed to recognize it.
 - c. Set how you wish the level to be displayed (% or actual height).
34. It is important to note the indicators on the sensor screen.
 - a. Signal = Bluetooth wireless signal strength from sensor to the device. Please note that this symbol may change to a Cloud symbol when the phone is out of Bluetooth range. Please refer to App Instructions on the Mopeka website for more detail.
 - b. The Quality indicator shown on a sensor's home screen (3 star scale) is used to understand if the sensor's ultrasonic measurement system is working correctly. Typically, if quality is low, (1 star or less) the sensor is mounted poorly: poorly positioned on the center bottom of tank, has debris on the tank in front of the rubber pad interfering with performance, or is lacking adequate sonic grease. Therefore, it is important to check Quality, especially during the first installation and setup. Typically, once installed correctly, with Quality at least 2 stars, it will not need change unless tank is disturbed such that it is no longer standing upright & level.

Display Users:

35. Pushing the display's button will initiate a scroll of the lights, once it obtains a new tank level reading from the sensor, that level will be displayed. It will remain lit for several seconds and then go back to sleep.
36. If the lights continue to scroll and never displays a level, the sensor and display are not communicating. Try pushing the button again. If the display still does not read, you may need to reposition the display, or check the FAQ's and Troubleshooting on our website.
37. Your display will automatically monitor tank readings every 30 minutes. If a tank level goes below 10% of full, the red light will start slowly flashing to alert you that your tank is near empty. The flashing may be stopped by pressing that Tank's button on the Display. This sequence then repeats every 8 hours.

BATTERY CHANGE INSTRUCTIONS

WARNING

EXPLOSION HAZARD-BATTERIES MUST ONLY BE CHANGED IN AN AREA FREE OF IGNITIBLE CONCENTRATIONS.

1. The enclosure lid is held in place by a snap fit, in 4 places. In the locations shown, insert small screwdriver, knife, or similar into gap between lid and base and pry outward to release snap fit. Lid can then be lifted out of assembly.

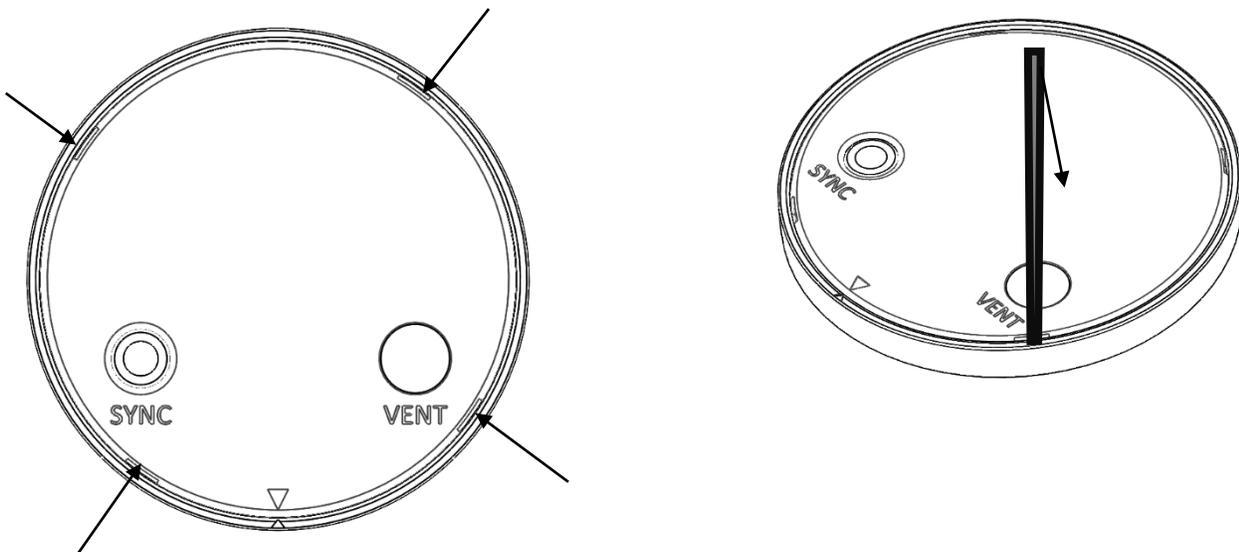

2. Pry battery so that it is released from plastic and battery contacts lips that hold it in position.
3. Place new battery, positive side up.
4. Position lid so that alignment marks meet, and then press at each snap fit slot until snap reengages. It may take a firm press to get the snaps reengaged.

BATTERY CHANGE INSTRUCTIONS-LED DISPLAY

1. The standalone display lid is held in place by a snap fit, in 2 places. In the locations shown, insert small screwdriver between lid and base and pry outward to release snap fit. Lid can then be lifted out of assembly.
2. Lift electronics board out of assembly and remove battery. Place new battery in same orientation.
3. Place electronics board back into the base. Place buttons and snap lid back to base.

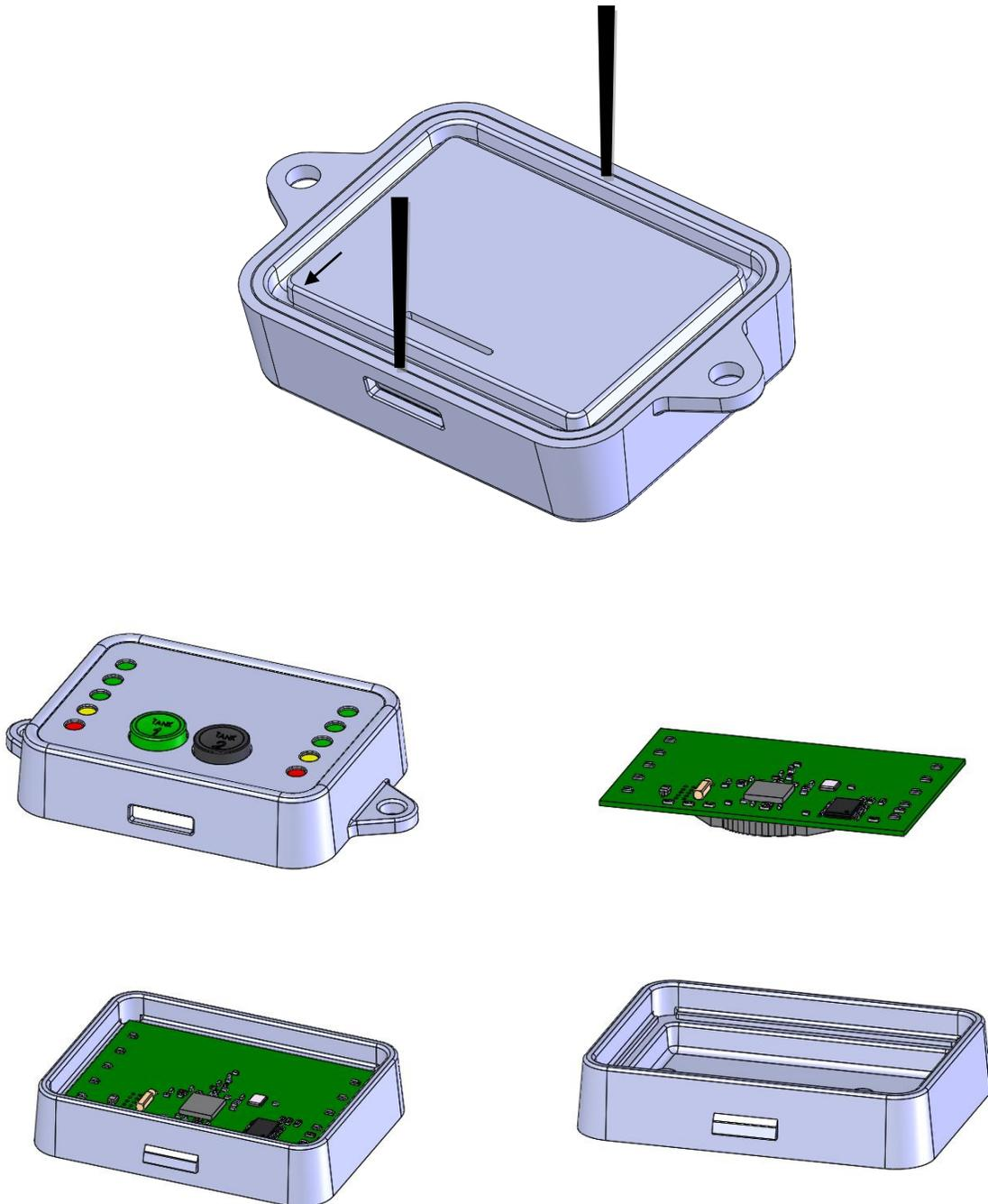



REVISION TABLE

<u>REVISION</u>	<u>DESCRIPTION</u>	<u>DATE</u>
A	RELEASE	2020.09.25
B	UPDATED FOR BATTERY CHANGE	2020.11.02
C	CORRECTED TEMP RANGE	2020.11.03
D	TEMP RANGE	2020.11.05
E	GENERAL UPDATE. ADDED ALUM TANK SECTION.	2020.11.16

Federal Communications Commission (FCC) Interference Statement

This equipment has been tested and found to comply with the limits for a Class B digital device, pursuant to Part 15 of the FCC Rules.

These limits are designed to provide reasonable protection against harmful interference in a residential installation. This equipment generate, uses and can radiate radio frequency energy and, if not installed and used in accordance with the instructions, may cause harmful interference to radio communications.

However, there is no guarantee that interference will not occur in a particular installation. If this equipment does cause harmful interference to radio or television reception, which can be determined by turning the equipment off and on, the user is encouraged to try to correct the interference by one of the following measures:

- Reorient or relocate the receiving antenna.
- Increase the separation between the equipment and receiver.
- Connect the equipment into an outlet on a circuit different from that to which the receiver is connected.
- Consult the dealer or an experienced radio/TV technician for help.

This device complies with Part 15 of the FCC Rules. Operation is subject to the following two conditions:

(1) This device may not cause harmful interference, and (2) this device must accept any interference received, including interference that may cause undesired operation.

FCC Caution: Any changes or modifications not expressly approved by the party responsible for compliance could void the user's authority to operate this equipment.

RF exposure warning

This equipment complies with FCC radiation exposure limits set forth for an uncontrolled environment.