



**SGS-CSTC Standards Technical Services Co., Ltd.
Shenzhen Branch**

No. 1 Workshop, M-10, Middle section, Science & Technology Park, Nanshan
District, Shenzhen, Guangdong, China 518057

Telephone: +86 (0) 755 2601 2053
Fax: +86 (0) 755 2671 0594
Email: ee.shenzhen@sgs.com

Report No.: SZEM160500388202
Page: 1 of 29

FCC REPORT

Application No. : SZEM1605003882CR (SGS SZ No.: T51610210125EM)
Applicant: PARADISE KIDS, LLC
Manufacturer: Zhongshan Mei Tung Electronics Ltd
Buyer: Paradise kids, LLC
Supplier: Zhongshan Mei Tung Electronics Ltd
Importer: Paradise kids, LLC
Product Name: R/C Cart
Model No.(EUT): WM051-A
FCC ID: 2AH6SWM051-A
Standards: 47 CFR Part 15, Subpart C (2015)
Date of Receipt: 2016-05-26
Date of Test: 2016-06-07
Date of Issue: 2016-06-13

Test Result:	PASS *
---------------------	---------------

* In the configuration tested, the EUT complied with the standards specified above.

Authorized Signature:



Jack Zhang
EMC Laboratory Manager

The manufacturer should ensure that all products in series production are in conformity with the product sample detailed in this report. If the product in this report is used in any configuration other than that detailed in the report, the manufacturer must ensure the new system complies with all relevant standards. Any mention of SGS International Electrical Approvals or testing done by SGS International Electrical Approvals in connection with, distribution or use of the product described in this report must be approved by SGS International Electrical Approvals in writing.

The report must not be used by the client to claim product certification, approval, or endorsement by NVLAP, NIST, or any agency of the federal government. All test results in this report can be traceable to National or International Standards.

"This document is issued by the Company subject to its General Conditions of Service printed overleaf, available on request or accessible at www.sgs.com/terms_and_conditions.htm and, for electronic format documents, subject to Terms and Conditions for Electronic Documents at www.sgs.com/terms_e-document.htm. Attention is drawn to the limitation of liability, indemnification and jurisdiction issues defined therein. Any holder of this document is advised that information contained hereon reflects the Company's findings at the time of its intervention only and within the limits of Client's instructions, if any. The Company's sole responsibility is to its Client and this document does not exonerate parties to a transaction from exercising all their rights and obligations under the transaction documents. This document cannot be reproduced except in full, without prior written approval of the Company. Any unauthorized alteration, forgery or falsification of the content or appearance of this document is unlawful and offenders may be prosecuted to the fullest extent of the law. Unless otherwise stated the results shown in this test report refer only to the sample(s) tested and such sample(s) are retained for 90 days only."



2 Version

Revision Record				
Version	Chapter	Date	Modifier	Remark
00		2016-06-13		Original

Authorized for issue by:				
Tested By		Gebin Sun		2016-06-07
		_____		_____
		(Gebin Sun) /Project Engineer		Date
Prepared By		Iris Zhou		2016-06-13
		_____		_____
		(Iris Zhou) /Clerk		Date
Checked By		Eric Fu		2016-06-13
		_____		_____
		(Eric Fu) /Reviewer		Date



3 Test Summary

Test Item	Test Requirement	Test method	Result
Antenna Requirement	47 CFR Part 15, Subpart C Section 15.203	ANSI C63.10 (2013)	PASS
Field Strength of the Fundamental Signal	47 CFR Part 15, Subpart C Section 15.249 (a)	ANSI C63.10 (2013)	PASS
Spurious Emissions	47 CFR Part 15, Subpart C Section 15.249 (a)/15.209	ANSI C63.10 (2013)	PASS
Restricted bands around fundamental frequency (Radiated Emission)	47 CFR Part 15, Subpart C Section 15.249(a)/15.205	ANSI C63.10 (2013)	PASS
20dB Occupied Bandwidth	47 CFR Part 15, Subpart C Section 15.215 (c)	ANSI C63.10 (2013)	PASS



4 Contents

	Page
1 COVER PAGE	1
2 VERSION	2
3 TEST SUMMARY	3
4 CONTENTS	4
5 GENERAL INFORMATION	5
5.1 CLIENT INFORMATION	5
5.2 GENERAL DESCRIPTION OF EUT	5
5.3 TEST ENVIRONMENT AND MODE	6
5.4 DESCRIPTION OF SUPPORT UNITS	6
5.5 TEST LOCATION	6
5.6 TEST FACILITY	7
5.7 DEVIATION FROM STANDARDS	7
5.8 ABNORMALITIES FROM STANDARD CONDITIONS	7
5.9 OTHER INFORMATION REQUESTED BY THE CUSTOMER	7
5.10 EQUIPMENT LIST	8
6 TEST RESULTS AND MEASUREMENT DATA	10
6.1 ANTENNA REQUIREMENT	10
6.2 SPURIOUS EMISSIONS	11
6.2.1 <i>Spurious Emissions</i>	11
6.3 RESTRICTED BANDS AROUND FUNDAMENTAL FREQUENCY	19
6.4 20DB BANDWIDTH	25
7 PHOTOGRAPHS	28
7.1 RADIATED EMISSION TEST SETUP	28
7.2 EUT CONSTRUCTIONAL DETAILS	29



5 General Information

5.1 Client Information

Applicant:	PARADISE KIDS, LLC
Address of Applicant:	Greenwich Connecticut United States 06831
Manufacturer:	Zhongshan Mei Tung Electronics Ltd
Buyer:	Paradise kids, LLC
Supplier:	Zhongshan Mei Tung Electronics Ltd
Importer:	Paradise kids, LLC

5.2 General Description of EUT

Name:	R/C Cart
Model No.:	WM051-A
Requested Age Grading:	3+
Country of Origin:	CHINA
Country of Destination:	USA
Operating Frequency:	2.4GHz(2410MHz、2443MHz、2475MHz)
Modulation Type:	GFSK
Sample Type:	Portable production
Antenna Type:	Integral
Antenna Gain:	0dBi
EUT Power Supply:	3V DC (2 x 1.5V "AAA" Size Battery)

Operation Frequency each of channel

Channel	Frequency
The Lowest channel(CH1)	2410MHz
The Middle channel(CH2)	2443MHz
The Highest channel(CH3)	2475MHz



5.3 Test Environment and Mode

Operating Environment:	
Temperature:	24.0 °C
Humidity:	52 % RH
Atmospheric Pressure:	1010mbar
Test mode:	
Transmitting mode:	Keep the EUT in transmitting mode with modulation.

5.4 Description of Support Units

The EUT has been tested independently.

5.5 Test Location

All tests were performed at:

SGS-CSTC Standards Technical Services Co., Ltd., Shenzhen Branch E&E Lab,
No. 1 Workshop, M-10, Middle Section, Science & Technology Park, Shenzhen, Guangdong, China.
518057.

Tel: +86 755 2601 2053 Fax: +86 755 2671 0594

No tests were sub-contracted.



5.6 Test Facility

The test facility is recognized, certified, or accredited by the following organizations:

- **CNAS (No. CNAS L2929)**

CNAS has accredited SGS-CSTC Standards Technical Services Co., Ltd. Shenzhen Branch EMC Lab to ISO/IEC 17025:2005 General Requirements for the Competence of Testing and Calibration Laboratories (CNAS-CL01 Accreditation Criteria for the Competence of Testing and Calibration Laboratories) for the competence in the field of testing.

- **A2LA (Certificate No. 3816.01)**

SGS-CSTC Standards Technical Services Co., Ltd., Shenzhen EMC Laboratory is accredited by the American Association for Laboratory Accreditation(A2LA). Certificate No. 3816.01.

- **VCCI**

The 10m Semi-anechoic chamber and Shielded Room of SGS-CSTC Standards Technical Services Co., Ltd. have been registered in accordance with the Regulations for Voluntary Control Measures with Registration No.: G-823, R-4188, T-1153 and C-2383 respectively.

- **FCC – Registration No.: 556682**

SGS-CSTC Standards Technical Services Co., Ltd., Shenzhen EMC Laboratory has been registered and fully described in a report filed with the (FCC) Federal Communications Commission. The acceptance letter from the FCC is maintained in our files. Registration No.: 556682.

- **Industry Canada (IC)**

Two 3m Semi-anechoic chambers and the 10m Semi-anechoic chamber of SGS-CSTC Standards Technical Services Co., Ltd. Shenzhen Branch EMC Lab have been registered by Certification and Engineering Bureau of Industry Canada for radio equipment testing with Registration No.: 4620C-1, 4620C-2, 4620C-3.

5.7 Deviation from Standards

None.

5.8 Abnormalities from Standard Conditions

None.

5.9 Other Information Requested by the Customer

None.

5.10 Equipment List

RE in Chamber						
Item	Test Equipment	Manufacturer	Model No.	Inventory No.	Cal. date (yyyy-mm-dd)	Cal.Due date (yyyy-mm-dd)
1	3m Semi-Anechoic Chamber	ETS-LINDGREN	N/A	SEM001-01	2016-05-13	2017-05-13
2	EMI Test Receiver	Agilent Technologies	N9038A	SEM004-05	2015-09-16	2016-09-16
3	BiConiLog Antenna (26-3000MHz)	ETS-LINDGREN	3142C	SEM003-01	2014-11-01	2017-11-01
4	Double-ridged horn (1-18GHz)	ETS-LINDGREN	3117	SEM003-11	2015-10-17	2018-10-17
5	Horn Antenna (18-26GHz)	ETS-LINDGREN	3160	SEM003-12	2014-11-24	2017-11-24
6	Pre-amplifier (0.1-1300MHz)	Agilent Technologies	8447D	SEM005-01	2016-04-25	2017-04-25
7	Band filter	Amindeon	Asi 3314	SEM023-01	N/A	N/A
8	DC Power Supply	Zhao Xin	RXN-305D	SEM011-02	2015-10-09	2016-10-09
9	Loop Antenna	Beijing Daze	ZN30401	SEM003-09	2015-05-13	2018-05-13

RE in Chamber						
Item	Test Equipment	Manufacturer	Model No.	Inventory No.	Cal. date (yyyy-mm-dd)	Cal.Due date (yyyy-mm-dd)
1	3m Semi-Anechoic Chamber	AUDIX	N/A	SEM001-02	2016-05-13	2017-05-13
2	EMI Test Receiver	Rohde & Schwarz	ESIB26	SEM004-04	2016-04-25	2017-04-25
3	BiConiLog Antenna (26-3000MHz)	ETS-Lindgren	3142C	SEM003-02	2014-11-15	2017-11-15
4	Amplifier (0.1-1300MHz)	HP	8447D	SEM005-02	2015-10-09	2016-10-09
5	Horn Antenna (1-18GHz)	Rohde & Schwarz	HF907	SEM003-07	2015-06-14	2018-06-14
6	Low Noise Amplifier	Black Diamond Series	BDLNA-0118-352810	SEM005-05	2015-10-09	2016-10-09
7	Band filter	Amindeon	Asi 3314	SEM023-01	N/A	N/A



RF connected test						
Item	Test Equipment	Manufacturer	Model No.	Inventory No.	Cal. date (yyyy-mm-dd)	Cal.Due date (yyyy-mm-dd)
1	DC Power Supply	ZhaoXin	RXN-305D	SEM011-02	2015-10-09	2016-10-09
2	Spectrum Analyzer	Rohde & Schwarz	FSP	SEM004-06	2015-10-17	2016-10-17
3	Signal Generator	Rohde & Schwarz	SML03	SEM006-02	2016-04-25	2017-04-25
4	Power Meter	Rohde & Schwarz	NRVS	SEM014-02	2015-10-09	2016-10-09

6 Test results and Measurement Data

6.1 Antenna Requirement

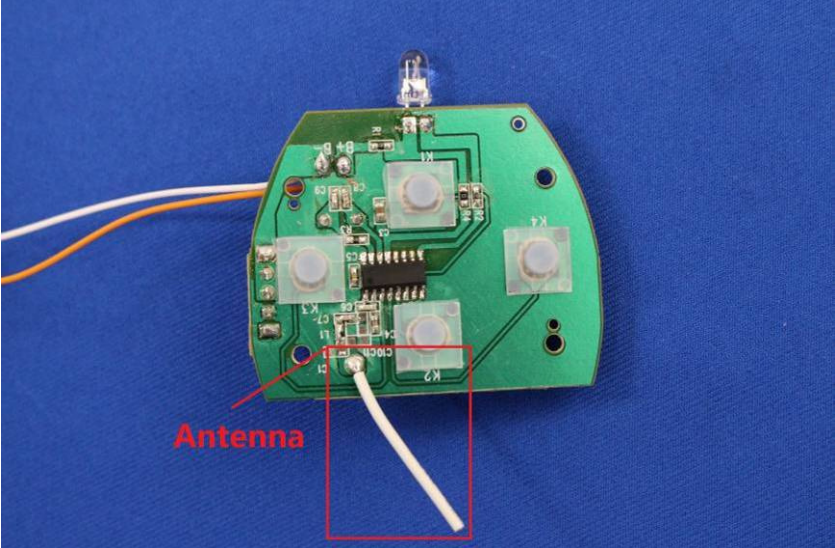
Standard requirement:	47 CFR Part 15C Section 15.203
<p>15.203 requirement: An intentional radiator shall be designed to ensure that no antenna other than that furnished by the responsible party shall be used with the device. The use of a permanently attached antenna or of an antenna that uses a unique coupling to the intentional radiator, the manufacturer may design the unit so that a broken antenna can be replaced by the user, but the use of a standard antenna jack or electrical connector is prohibited.</p>	
EUT Antenna:	
<p>The antenna is integrated on the main PCB and no consideration of replacement. The best case gain of the antenna is 0Bi.</p>	



6.2 Spurious Emissions

6.2.1 Spurious Emissions

Test Requirement:	47 CFR Part 15C Section 15.249 and 15.209				
Test Method:	ANSI C63.10: 2013 Clause 6.4,6.5 and 6.6				
Test Site:	Measurement Distance: 3m				
Receiver Setup:	Frequency	Detector	RBW	VBW	Remark
	0.009MHz-0.090MHz	Peak	10kHz	30KHz	Peak
	0.009MHz-0.090MHz	Average	10kHz	30KHz	Average
	0.090MHz-0.110MHz	Quasi-peak	10kHz	30KHz	Quasi-peak
	0.110MHz-0.490MHz	Peak	10kHz	30KHz	Peak
	0.110MHz-0.490MHz	Average	10kHz	30KHz	Average
	0.490MHz -30MHz	Quasi-peak	10kHz	30kHz	Quasi-peak
	30MHz-1GHz	Quasi-peak	100 kHz	300KHz	Quasi-peak
	Above 1GHz	Peak	1MHz	3MHz	Peak
Peak		1MHz	10Hz	Average	
Limit: (Spurious Emissions)	Frequency	Field strength (microvolt/meter)	Limit (dBuV/m)	Remark	Measurement distance (m)
	0.009MHz-0.490MHz	2400/F (kHz)	-	-	300
	0.490MHz-1.705MHz	24000/F (kHz)	-	-	30
	1.705MHz-30MHz	30	-	-	30
	30MHz-88MHz	100	40.0	Quasi-peak	3
	88MHz-216MHz	150	43.5	Quasi-peak	3
	216MHz-960MHz	200	46.0	Quasi-peak	3
	960MHz-1GHz	500	54.0	Quasi-peak	3
	Above 1GHz	500	54.0	Average	3
Note: 15.35(b), Unless otherwise specified, the limit on peak radio frequency emissions is 20dB above the maximum permitted average emission limit applicable to the equipment under test. This peak limit applies to the total peak emission level radiated by the device.					
Limit: (Field strength of the fundamental signal)	Frequency	Limit (dBuV/m @3m)		Remark	
	2400MHz-2483.5MHz	94.0		Average Value	
		114.0		Peak Value	
Test Setup:					

"This document is issued by the Company subject to its General Conditions of Service printed overleaf, available on request or accessible at www.sgs.com/terms_and_conditions.htm and, for electronic format documents, subject to Terms and Conditions for Electronic Documents at www.sgs.com/terms_e-document.htm. Attention is drawn to the limitation of liability, indemnification and jurisdiction issues defined therein. Any holder of this document is advised that information contained hereon reflects the Company's findings at the time of its intervention only and within the limits of Client's instructions, if any. The Company's sole responsibility is to its Client and this document does not exonerate parties to a transaction from exercising all their rights and obligations under the transaction documents. This document cannot be reproduced except in full, without prior written approval of the Company. Any unauthorized alteration, forgery or falsification of the content or appearance of this document is unlawful and offenders may be prosecuted to the fullest extent of the law. Unless otherwise stated the results shown in this test report refer only to the sample(s) tested and such sample(s) are retained for 90 days only."

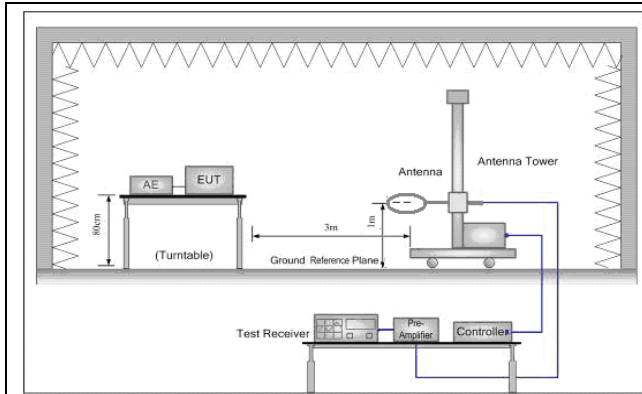

Figure 1. Below 30MHz

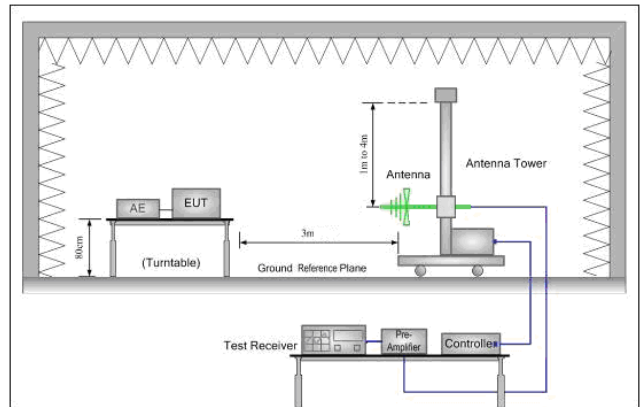

Figure 2. 30MHz to 1GHz

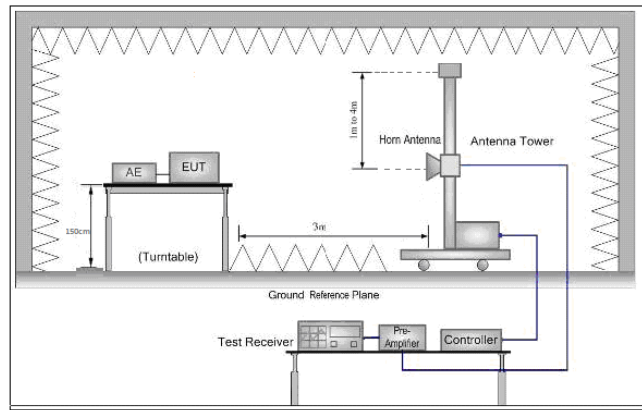

Figure 3. Above 1 GHz

<p>Test Procedure:</p>	<ol style="list-style-type: none"> For below 1GHz, the EUT was placed on the top of a rotating table 0.8 meters above the ground at a 3 meter semi-anechoic chamber. The table was rotated 360 degrees to determine the position of the highest radiation. For above 1GHz, the EUT was placed on the top of a rotating table 1.5 meters above the ground at a 3 meter fully-anechoic chamber. The table was rotated 360 degrees to determine the position of the highest radiation The EUT was set 3 meters away from the interference-receiving antenna, which was mounted on the top of a variable-height antenna tower. The antenna height is varied from one meter to four meters above the ground to determine the maximum value of the field strength. Both horizontal and vertical polarizations of the antenna are set to make the measurement. For each suspected emission, the EUT was arranged to its worst case and then the antenna was tuned to heights from 1 meter to 4 meters (for the test frequency of below 30MHz, the antenna was tuned to heights 1 meter) and the rotatable table was turned from 0 degrees to 360 degrees to find the maximum reading. The test-receiver system was set to Peak Detect Function and Specified Bandwidth with Maximum Hold Mode. If the emission level of the EUT in peak mode was 10dB lower than the limit specified, then testing could be stopped and the peak values of the EUT would be reported. Otherwise the emissions that did not have 10dB margin would be re-tested one by one using peak, quasi-peak or average method as specified and then reported in a data sheet. Test the EUT in the lowest channel, the middle channel, the Highest channel
------------------------	---



	i. The radiation measurements are performed in X, Y, Z axis positioning for Transmitting mode, And found the X axis positioning which it is worse case. j. Repeat above procedures until all frequencies measured was complete.
Instruments Used:	Refer to section 5.10 for details
Test Mode:	Transmitting with GFSK modulation. Transmitting mode
Test Results:	Pass

Measurement Data

6.2.1.1 Field Strength Of The Fundamental Signal

Peak value:

Frequency (MHz)	Cable Loss (dB)	Antenna Factor (dB/m)	Preamp Factor (dB)	Read Level (dBuV)	Level (dBuV/m)	Limit Line (dBuV/m)	Over Limit (dB)	Polarization
2410.174	28.65	5.35	38.11	93.99	89.88	114.00	-24.12	Vertical
2410.174	28.65	5.35	38.11	97.76	93.65	114.00	-20.35	Horizontal
2443.123	28.8	5.38	38.11	90.62	86.69	114.00	-27.31	Vertical
2443.123	28.8	5.38	38.11	96.62	92.69	114.00	-21.31	Horizontal
2474.925	28.95	5.40	38.12	87.97	84.20	114.00	-29.80	Vertical
2475.284	28.95	5.40	38.12	94.65	90.88	114.00	-23.12	Horizontal

Remark:

The peak field strength of any emission shall not exceed the maximum permitted average limits specified above by more than 20 dB under any condition of modulation. So, only the peak measurements were shown in the report.

"This document is issued by the Company subject to its General Conditions of Service printed overleaf, available on request or accessible at www.sgs.com/terms_and_conditions.htm and, for electronic format documents, subject to Terms and Conditions for Electronic Documents at www.sgs.com/terms_e-document.htm. Attention is drawn to the limitation of liability, indemnification and jurisdiction issues defined therein. Any holder of this document is advised that information contained hereon reflects the Company's findings at the time of its intervention only and within the limits of Client's instructions, if any. The Company's sole responsibility is to its Client and this document does not exonerate parties to a transaction from exercising all their rights and obligations under the transaction documents. This document cannot be reproduced except in full, without prior written approval of the Company. Any unauthorized alteration, forgery or falsification of the content or appearance of this document is unlawful and offenders may be prosecuted to the fullest extent of the law. Unless otherwise stated the results shown in this test report refer only to the sample(s) tested and such sample(s) are retained for 90 days only."



6.2.1.2 Spurious Emissions

30MHz~1GHz			
Test mode:	Transmitter mode	Polarization:	Vertical

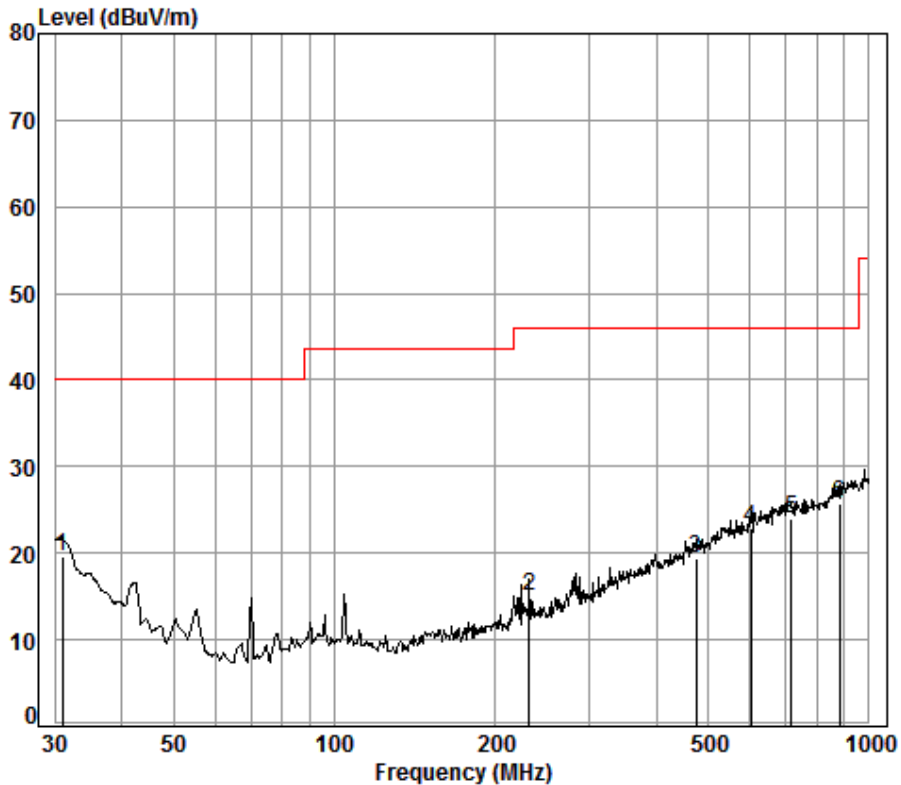

Condition: 3m Vertical
Job No. : 3882CR
Test Mode: TX mode

	Freq	Cable Loss	Ant Factor	Preamp Factor	Read Level	Limit Level	Limit Line	Over Limit
	MHz	dB	dB/m	dB	dBuV	dBuV/m	dBuV/m	dB
1	30.96	0.60	18.36	26.00	26.77	19.73	40.00	-20.27
2	231.72	1.58	11.62	25.75	27.65	15.10	46.00	-30.90
3	475.50	2.51	17.70	25.63	24.92	19.50	46.00	-26.50
4	601.43	2.70	19.73	25.60	25.95	22.78	46.00	-23.22
5	716.68	2.96	21.63	25.72	25.17	24.04	46.00	-21.96
6 pp	881.41	3.53	22.90	25.19	24.59	25.83	46.00	-20.17

"This document is issued by the Company subject to its General Conditions of Service printed overleaf, available on request or accessible at www.sgs.com/terms_and_conditions.htm and, for electronic format documents, subject to Terms and Conditions for Electronic Documents at www.sgs.com/terms_e-document.htm. Attention is drawn to the limitation of liability, indemnification and jurisdiction issues defined therein. Any holder of this document is advised that information contained hereon reflects the Company's findings at the time of its intervention only and within the limits of Client's instructions, if any. The Company's sole responsibility is to its Client and this document does not exonerate parties to a transaction from exercising all their rights and obligations under the transaction documents. This document cannot be reproduced except in full, without prior written approval of the Company. Any unauthorized alteration, forgery or falsification of the content or appearance of this document is unlawful and offenders may be prosecuted to the fullest extent of the law. Unless otherwise stated the results shown in this test report refer only to the sample(s) tested and such sample(s) are retained for 90 days only."



Test mode:	Transmitter mode	Polarization:	Horizontal
------------	------------------	---------------	------------

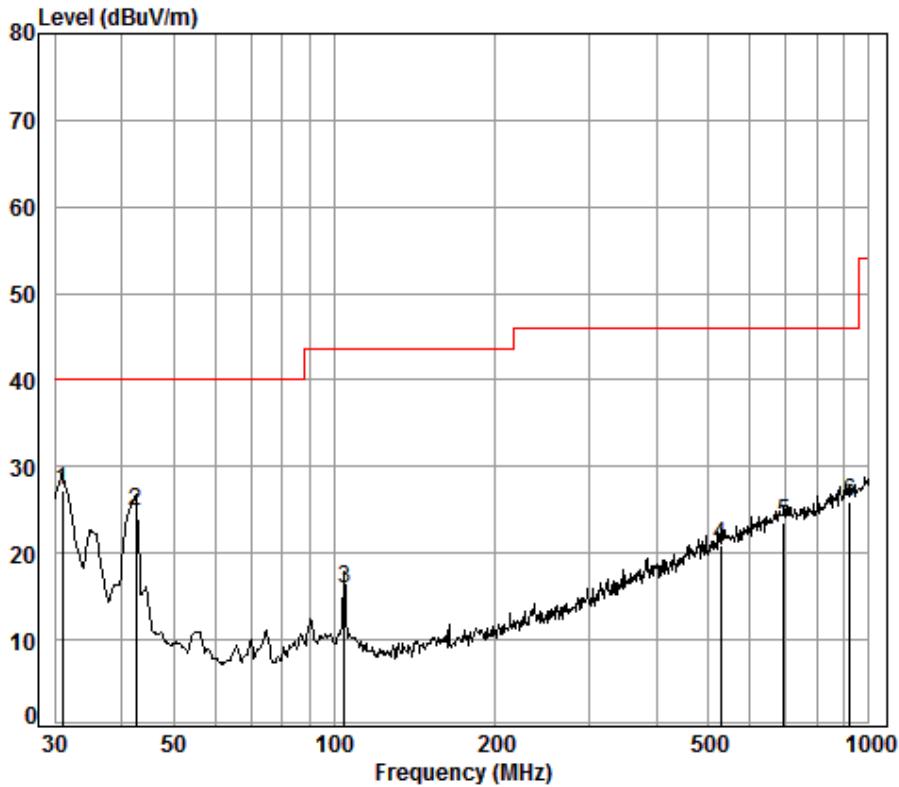

Condition: 3m Horizontal

Job No. : 3882CR

Test Mode: TX mode

	Freq	Cable Loss	Ant Factor	Preamp Factor	Read Level	Level	Limit Line	Over Limit
	MHz	dB	dB/m	dB	dBuV	dBuV/m	dBuV/m	dB
1 pp	30.96	0.60	18.36	26.00	34.37	27.33	40.00	-12.67
2	42.60	0.66	11.99	25.97	38.14	24.82	40.00	-15.18
3	104.54	1.21	8.91	25.89	31.63	15.86	43.50	-27.64
4	528.25	2.63	18.48	25.62	25.40	20.89	46.00	-25.11
5	691.99	2.89	21.57	25.70	24.80	23.56	46.00	-22.44
6	919.29	3.62	23.35	24.93	23.96	26.00	46.00	-20.00

"This document is issued by the Company subject to its General Conditions of Service printed overleaf, available on request or accessible at www.sgs.com/terms_and_conditions.htm and, for electronic format documents, subject to Terms and Conditions for Electronic Documents at www.sgs.com/terms_e-document.htm. Attention is drawn to the limitation of liability, indemnification and jurisdiction issues defined therein. Any holder of this document is advised that information contained hereon reflects the Company's findings at the time of its intervention only and within the limits of Client's instructions, if any. The Company's sole responsibility is to its Client and this document does not exonerate parties to a transaction from exercising all their rights and obligations under the transaction documents. This document cannot be reproduced except in full, without prior written approval of the Company. Any unauthorized alteration, forgery or falsification of the content or appearance of this document is unlawful and offenders may be prosecuted to the fullest extent of the law. Unless otherwise stated the results shown in this test report refer only to the sample(s) tested and such sample(s) are retained for 90 days only."



Above 1GHz								
Test mode:	Transmitting		Test channel:		Lowest	Remark:		Peak
Frequency (MHz)	Antenna Factor (dB/m)	Cable Loss (dB)	Preamp Factor (dB)	Read Level (dBuV)	Level (dBuV/m)	Limit Line (dBuV/m)	Over Limit (dB)	Polarization
3737.975	32.66	7.72	38.46	46.11	48.03	74	-25.97	Vertical
4820.000	34.12	8.89	38.75	49.09	53.35	74	-20.65	Vertical
6051.874	34.73	10.49	38.89	46.45	52.78	74	-21.22	Vertical
7230.000	35.58	10.69	37.63	47.34	55.98	74	-18.02	Vertical
9640.000	37.10	12.52	36.30	36.22	49.54	74	-24.46	Vertical
12603.270	37.90	14.44	37.75	38.86	53.45	74	-20.55	Vertical
3836.607	32.94	7.75	38.50	45.62	47.81	74	-26.19	Horizontal
4820.000	34.12	8.89	38.75	49.59	53.85	74	-20.15	Horizontal
6069.413	34.74	10.47	38.87	46.03	52.37	74	-21.63	Horizontal
7230.000	35.58	10.69	37.63	48.60	57.24	74	-16.76	Horizontal
9640.000	37.10	12.52	36.30	36.75	50.07	74	-23.93	Horizontal
12603.270	37.90	14.44	37.75	38.39	52.98	74	-21.02	Horizontal

Test mode:	Transmitting		Test channel:		Lowest	Remark:		Average
Frequency (MHz)	Cable Loss (dB)	Antenna Factor (dB/m)	Preamp Factor (dB)	Read Level (dBuV)	Level (dBuV/m)	Limit Line (dBuV/m)	Over Limit (dB)	Polarization
7230.000	35.58	10.69	37.63	34.01	42.65	54	-11.35	Vertical
7230.000	35.58	10.69	37.63	36.01	44.65	54	-9.35	Horizontal

"This document is issued by the Company subject to its General Conditions of Service printed overleaf, available on request or accessible at www.sgs.com/terms_and_conditions.htm and, for electronic format documents, subject to Terms and Conditions for Electronic Documents at www.sgs.com/terms_e-document.htm. Attention is drawn to the limitation of liability, indemnification and jurisdiction issues defined therein. Any holder of this document is advised that information contained hereon reflects the Company's findings at the time of its intervention only and within the limits of Client's instructions, if any. The Company's sole responsibility is to its Client and this document does not exonerate parties to a transaction from exercising all their rights and obligations under the transaction documents. This document cannot be reproduced except in full, without prior written approval of the Company. Any unauthorized alteration, forgery or falsification of the content or appearance of this document is unlawful and offenders may be prosecuted to the fullest extent of the law. Unless otherwise stated the results shown in this test report refer only to the sample(s) tested and such sample(s) are retained for 90 days only."



Test mode:		Transmitting		Test channel:		Middle		Remark:		Peak
Frequency (MHz)	Cable Loss (dB)	Antenna Factor (dB/m)	Preamp Factor (dB)	Read Level (dBuV)	Level (dBuV/m)	Limit Line (dBuV/m)	Over Limit (dB)	Polarization		
3825.521	32.93	7.75	38.49	45.48	47.67	74	-26.33	Vertical		
4886.000	34.19	8.98	38.77	48.02	52.42	74	-21.58	Vertical		
5982.226	34.66	10.51	38.96	45.91	52.12	74	-21.88	Vertical		
7329.000	35.54	10.73	37.59	49.05	57.73	74	-16.27	Vertical		
9772.000	37.10	12.59	36.13	40.05	53.61	74	-20.39	Vertical		
12603.270	37.90	14.44	37.75	38.36	52.95	74	-21.05	Vertical		
3825.521	32.93	7.75	38.49	45.86	48.05	74	-25.95	Horizontal		
4886.000	34.19	8.98	38.77	52.69	57.09	74	-16.91	Horizontal		
6034.386	34.72	10.52	38.91	46.31	52.64	74	-21.36	Horizontal		
7329.000	35.54	10.73	37.59	50.07	58.75	74	-15.25	Horizontal		
9772.000	37.10	12.59	36.13	39.37	52.93	74	-21.07	Horizontal		
12713.160	37.96	14.75	37.86	38.08	52.93	74	-21.07	Horizontal		

Test mode:		Transmitting		Test channel:		Middle		Remark:		Average
Frequency (MHz)	Cable Loss (dB)	Antenna Factor (dB/m)	Preamp Factor (dB)	Read Level (dBuV)	Level (dBuV/m)	Limit Line (dBuV/m)	Over Limit (dB)	Polarization		
7329.000	35.54	10.73	37.59	36.00	44.68	54	-9.32	Vertical		
4886.000	34.19	8.98	38.77	40.00	44.40	54	-9.60	Horizontal		
7329.000	35.54	10.73	37.59	37.00	45.68	54	-8.32	Horizontal		

"This document is issued by the Company subject to its General Conditions of Service printed overleaf, available on request or accessible at www.sgs.com/terms_and_conditions.htm and, for electronic format documents, subject to Terms and Conditions for Electronic Documents at www.sgs.com/terms_e-document.htm. Attention is drawn to the limitation of liability, indemnification and jurisdiction issues defined therein. Any holder of this document is advised that information contained hereon reflects the Company's findings at the time of its intervention only and within the limits of Client's instructions, if any. The Company's sole responsibility is to its Client and this document does not exonerate parties to a transaction from exercising all their rights and obligations under the transaction documents. This document cannot be reproduced except in full, without prior written approval of the Company. Any unauthorized alteration, forgery or falsification of the content or appearance of this document is unlawful and offenders may be prosecuted to the fullest extent of the law. Unless otherwise stated the results shown in this test report refer only to the sample(s) tested and such sample(s) are retained for 90 days only."



Test mode:		Transmitting		Test channel:		Highest		Remark:		Peak
Frequency (MHz)	Cable Loss (dB)	Antenna Factor (dB/m)	Preamp Factor (dB)	Read Level (dBuV)	Level (dBuV/m)	Limit Line (dBuV/m)	Over Limit (dB)	Polarization		
3803.444	32.90	7.74	38.49	45.97	48.12	74	-25.88	Vertical		
4950.000	34.25	9.07	38.78	49.07	53.61	74	-20.39	Vertical		
6069.413	34.74	10.47	38.87	46.09	52.43	74	-21.57	Vertical		
7425.000	35.56	10.76	37.54	42.73	51.51	74	-22.49	Vertical		
9900.000	37.20	12.66	35.96	39.77	53.67	74	-20.33	Vertical		
12603.270	37.90	14.44	37.75	37.52	52.11	74	-21.89	Vertical		
3781.495	32.83	7.73	38.48	44.86	46.94	74	-27.06	Horizontal		
4950.000	34.25	9.07	38.78	53.12	57.66	74	-16.34	Horizontal		
6104.642	34.75	10.42	38.82	45.51	51.86	74	-22.14	Horizontal		
7425.000	35.56	10.76	37.54	43.57	52.35	74	-21.65	Horizontal		
9900.000	37.20	12.66	35.96	39.13	53.03	74	-20.97	Horizontal		
12639.790	37.92	14.55	37.79	37.94	52.62	74	-21.38	Horizontal		

Test mode:		Transmitting		Test channel:		Highest		Remark:		Average
Frequency (MHz)	Cable Loss (dB)	Antenna Factor (dB/m)	Preamp Factor (dB)	Read Level (dBuV)	Level (dBuV/m)	Limit Line (dBuV/m)	Over Limit (dB)	Polarization		
4950.000	34.25	9.07	38.78	40.00	44.54	54	-9.46	Horizontal		

Remark:

- 1) The field strength is calculated by adding the Antenna Factor, Cable Factor & Pre-amplifier. The basic equation with a sample calculation is as follows:
 Final Test Level = Receiver Reading + Antenna Factor + Cable Factor – Pre-amplifier Factor
- 2) Scan from 9kHz to 25GHz, The disturbance above 13GHz and below 30MHz was very low, and the above harmonics were the highest point could be found when testing, so only the above harmonics had been displayed. The amplitude of spurious emissions from the radiator which are attenuated more than 20dB below the limit need not be reported .
- 3) As shown in this section, for frequencies above 1GHz, the field strength limits are based on average limits. However, the peak field strength of any emission shall not exceed the maximum permitted average limits specified above by more than 20 dB under any condition of modulation. So, only the above measurement data were shown in the report.

"This document is issued by the Company subject to its General Conditions of Service printed overleaf, available on request or accessible at www.sgs.com/terms_and_conditions.htm and, for electronic format documents, subject to Terms and Conditions for Electronic Documents at www.sgs.com/terms_e-document.htm. Attention is drawn to the limitation of liability, indemnification and jurisdiction issues defined therein. Any holder of this document is advised that information contained hereon reflects the Company's findings at the time of its intervention only and within the limits of Client's instructions, if any. The Company's sole responsibility is to its Client and this document does not exonerate parties to a transaction from exercising all their rights and obligations under the transaction documents. This document cannot be reproduced except in full, without prior written approval of the Company. Any unauthorized alteration, forgery or falsification of the content or appearance of this document is unlawful and offenders may be prosecuted to the fullest extent of the law. Unless otherwise stated the results shown in this test report refer only to the sample(s) tested and such sample(s) are retained for 90 days only."

6.3 Restricted bands around fundamental frequency

Test Requirement:	47 CFR Part 15C Section 15.209 and 15.205	
Test Method:	ANSI C63.10: 2013 Clause 6.10	
Test site:	Measurement Distance: 3m	
Limit(band edge):	Emissions radiated outside of the specified frequency bands, except for harmonics, shall be attenuated by at least 50 dB below the level of the fundamental or to the general radiated emission limits in Section 15.209, whichever is the lesser attenuation.	
	Frequency	Limit (dBuV/m @3m)
	30MHz-88MHz	40.0
	88MHz-216MHz	43.5
	216MHz-960MHz	46.0
	960MHz-1GHz	54.0
Above 1GHz	54.0	Average Value
	74.0	Peak Value

Test Setup:

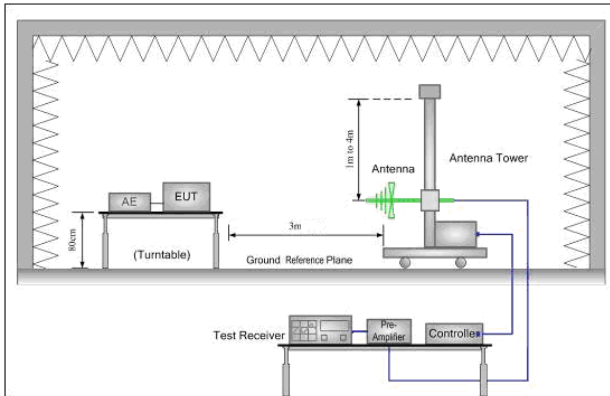

Figure 1. 30MHz to 1GHz

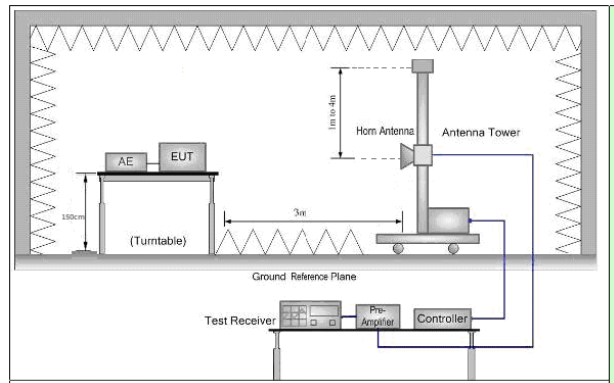

Figure 2. Above 1 GHz



Test Procedure:	<ol style="list-style-type: none">a. For below 1GHz, the EUT was placed on the top of a rotating table 0.8 meters above the ground at a 3 meter semi-anechoic chamber. The table was rotated 360 degrees to determine the position of the highest radiation.b. For above 1GHz, the EUT was placed on the top of a rotating table 1.5 meters above the ground at a 3 meter fully-anechoic chamber. The table was rotated 360 degrees to determine the position of the highest radiation.c. The EUT was set 3 meters away from the interference-receiving antenna, which was mounted on the top of a variable-height antenna tower.d. The antenna height is varied from one meter to four meters above the ground to determine the maximum value of the field strength. Both horizontal and vertical polarizations of the antenna are set to make the measurement.e. For each suspected emission, the EUT was arranged to its worst case and then the antenna was tuned to heights from 1 meter to 4 meters and the rotatable table was turned from 0 degrees to 360 degrees to find the maximum reading.f. The test-receiver system was set to Peak Detect Function and Specified Bandwidth with Maximum Hold Mode.g. Place a marker at the end of the restricted band closest to the transmit frequency to show compliance. Also measure any emissions in the restricted bands. Save the spectrum analyzer plot. Repeat for each power and modulation for lowest and highest channelh. Test the EUT in the lowest channel , the Highest channeli. The radiation measurements are performed in X, Y, Z axis positioning for Transmitting mode,And found the X axis positioning which it is worse case..j. Repeat above procedures until all frequencies measured was complete.
Instruments Used:	Refer to section 5.10 for details
Test Mode:	Transmitting with GFSK modulation. Transmitting mode
Test Results:	Pass



Band edge (Radiated Emission)					
Test mode:	Transmitting	Test channel:	Lowest	Remark:	Vertical

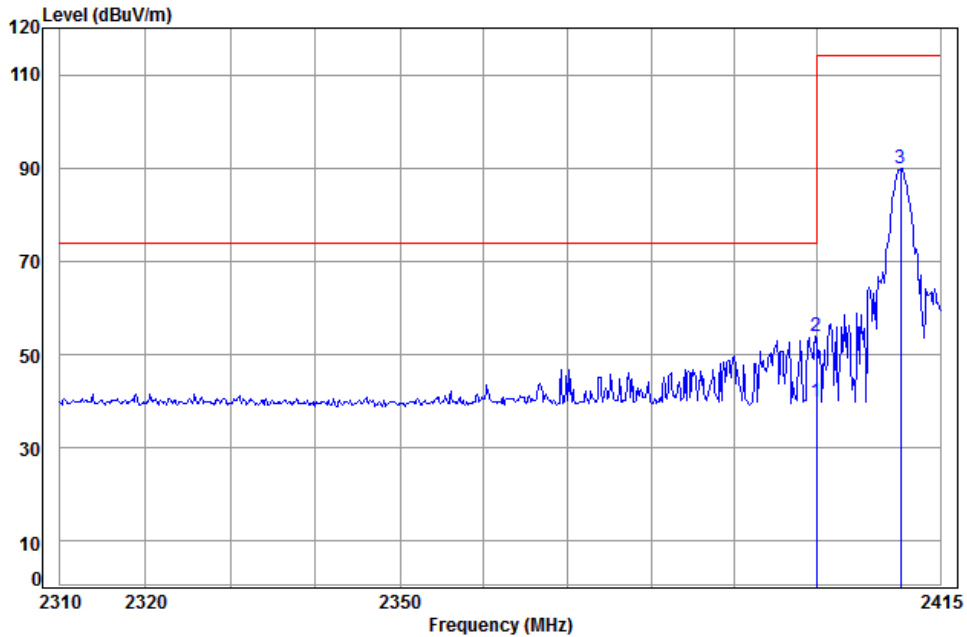

Condition: 3m Vertical

Job No: : 3882CR

Mode: : 2410 Band edge

	Freq	Cable Loss	Ant Factor	Preamp Factor	Read Level	Limit Level	Over Line	Over Limit	Remark
	MHz	dB	dB/m	dB	dBuV	dBuV/m	dBuV/m	dB	
1 pp	2400.000	5.34	28.60	38.11	44.00	39.83	54.00	-14.17	Average
2 pk	2400.000	5.34	28.60	38.11	58.07	53.90	74.00	-20.10	Peak
3	2410.174	5.35	28.65	38.11	93.99	89.88	114.00	-24.12	Peak

"This document is issued by the Company subject to its General Conditions of Service printed overleaf, available on request or accessible at www.sgs.com/terms_and_conditions.htm and, for electronic format documents, subject to Terms and Conditions for Electronic Documents at www.sgs.com/terms_e-document.htm. Attention is drawn to the limitation of liability, indemnification and jurisdiction issues defined therein. Any holder of this document is advised that information contained hereon reflects the Company's findings at the time of its intervention only and within the limits of Client's instructions, if any. The Company's sole responsibility is to its Client and this document does not exonerate parties to a transaction from exercising all their rights and obligations under the transaction documents. This document cannot be reproduced except in full, without prior written approval of the Company. Any unauthorized alteration, forgery or falsification of the content or appearance of this document is unlawful and offenders may be prosecuted to the fullest extent of the law. Unless otherwise stated the results shown in this test report refer only to the sample(s) tested and such sample(s) are retained for 90 days only."



Test mode:	Transmitting	Test channel:	Lowest	Remark:	Horizontal
------------	--------------	---------------	--------	---------	------------

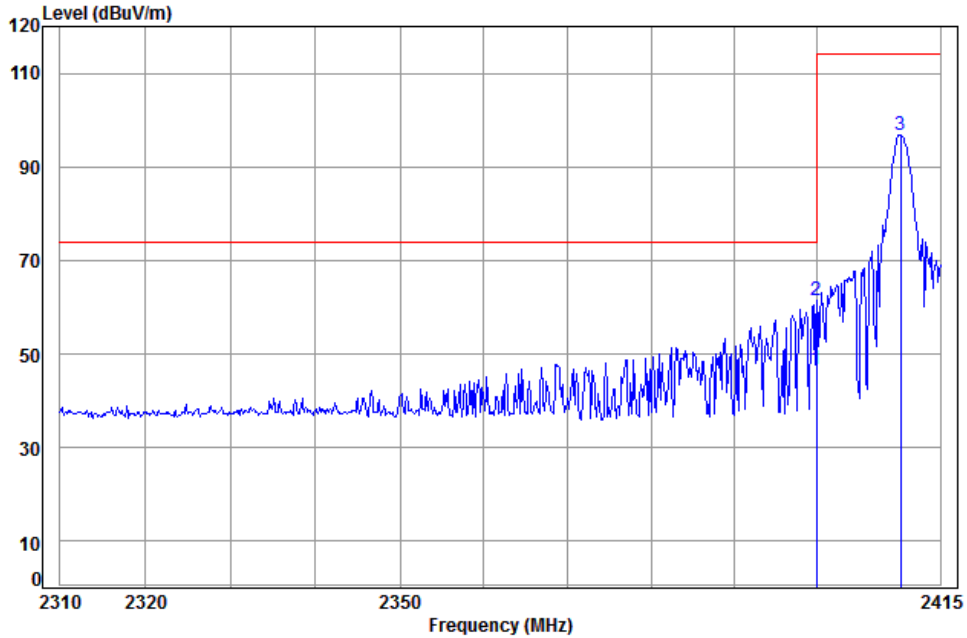

Condition: 3m Horizontal
Job No: : 3882CR
Mode: : 2410 Band edge

	Freq	Cable Loss	Ant Factor	Preamp Factor	Read Level	Limit Level	Over Line	Over Limit	Remark
	MHz	dB	dB/m	dB	dBuV	dBuV/m	dBuV/m	dB	
1 pp	2400.000	5.34	28.60	38.11	51.00	46.83	54.00	-7.17	Average
2 pk	2400.000	5.34	28.60	38.11	65.63	61.46	74.00	-12.54	Peak
3	2410.174	5.35	28.65	38.11	100.76	96.65	114.00	-17.35	Peak

"This document is issued by the Company subject to its General Conditions of Service printed overleaf, available on request or accessible at www.sgs.com/terms_and_conditions.htm and, for electronic format documents, subject to Terms and Conditions for Electronic Documents at www.sgs.com/terms_e-document.htm. Attention is drawn to the limitation of liability, indemnification and jurisdiction issues defined therein. Any holder of this document is advised that information contained hereon reflects the Company's findings at the time of its intervention only and within the limits of Client's instructions, if any. The Company's sole responsibility is to its Client and this document does not exonerate parties to a transaction from exercising all their rights and obligations under the transaction documents. This document cannot be reproduced except in full, without prior written approval of the Company. Any unauthorized alteration, forgery or falsification of the content or appearance of this document is unlawful and offenders may be prosecuted to the fullest extent of the law. Unless otherwise stated the results shown in this test report refer only to the sample(s) tested and such sample(s) are retained for 90 days only."



Test mode:	Transmitting	Test channel:	Highest	Remark:	Vertical
------------	--------------	---------------	---------	---------	----------

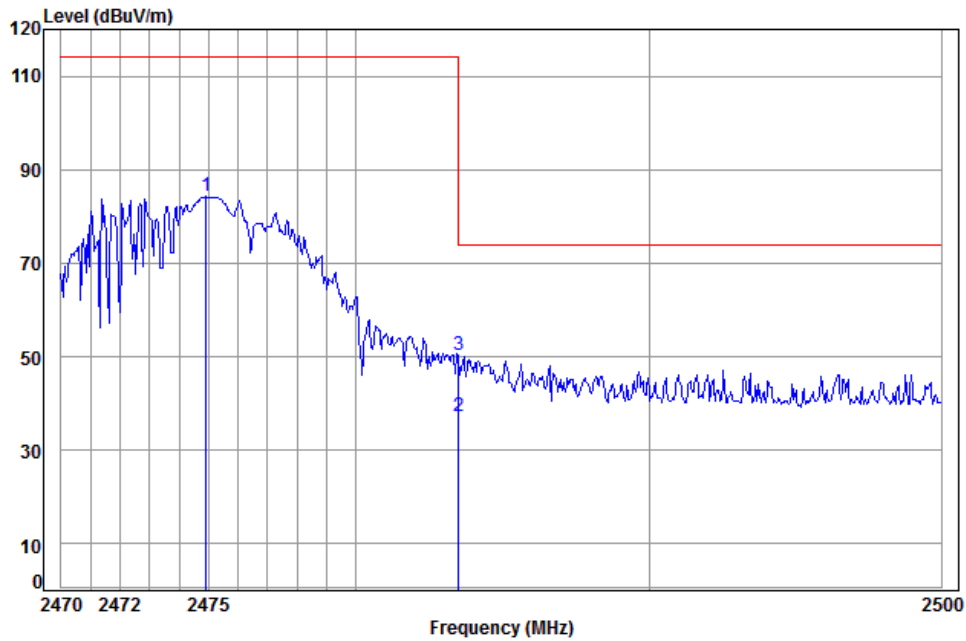

Condition: 3m Vertical

Job No: : 3882CR

Mode: : 2475 Band edge

	Freq	Cable Loss	Ant Factor	Preamp Factor	Read Level	Limit Level	Over Line	Over Limit	Remark
	MHz	dB	dB/m	dB	dBuV	dBuV/m	dBuV/m	dB	
1	2474.925	5.40	28.95	38.12	87.97	84.20	114.00	-29.80	Peak
2	pp 2483.500	5.41	28.98	38.12	41.01	37.28	54.00	-16.72	Average
3	pk 2483.500	5.41	28.98	38.12	54.06	50.33	74.00	-23.67	Peak



Test mode:	Transmitting	Test channel:	Highest	Remark:	Horizontal
------------	--------------	---------------	---------	---------	------------

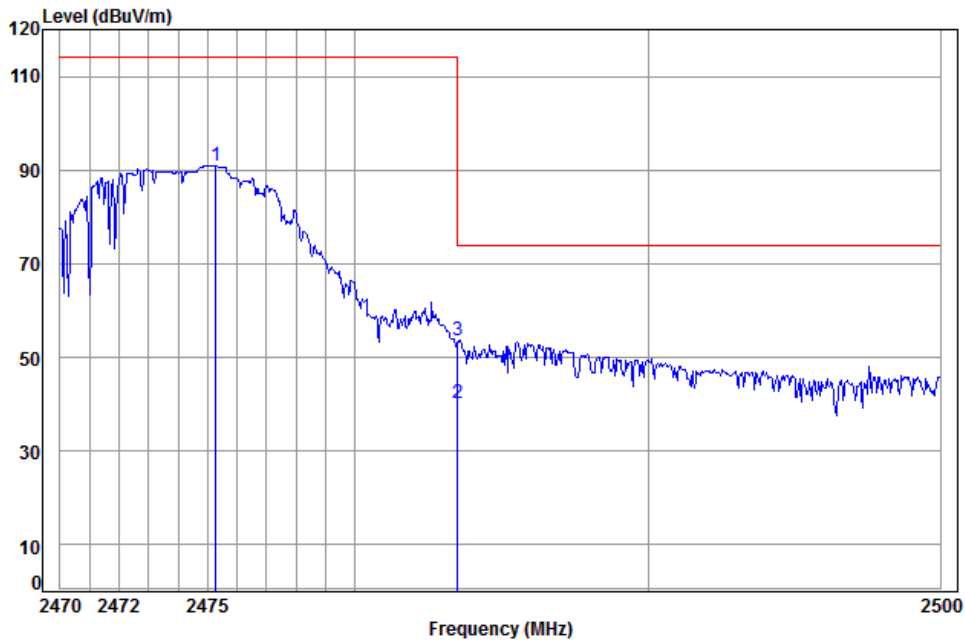

Condition: 3m Horizontal
Job No: : 3882CR
Mode: : 2475 Band edge

	Freq	Cable Loss	Ant Factor	Preamp Factor	Read Level	Limit Level	Over Limit	Remark
	MHz	dB	dB/m	dB	dBuV	dBuV/m	dBuV/m	dB
1	2475.284	5.40	28.95	38.12	94.65	90.88	114.00	-23.12 Peak
2 pp	2483.500	5.41	28.98	38.12	44.01	40.28	54.00	-13.72 Average
3 pk	2483.500	5.41	28.98	38.12	57.25	53.52	74.00	-20.48 Peak

Note:

The field strength is calculated by adding the Antenna Factor, Cable Factor & Preamplifier. The basic equation with a sample calculation is as follows:

$$\text{Final Test Level} = \text{Receiver Reading} + \text{Antenna Factor} + \text{Cable Factor} - \text{Preamplifier Factor}$$

The peak field strength of any emission shall not exceed the maximum permitted average limits specified above by more than 20 dB under any condition of modulation. So, only the peak measurements were shown in the report.

"This document is issued by the Company subject to its General Conditions of Service printed overleaf, available on request or accessible at www.sgs.com/terms_and_conditions.htm and, for electronic format documents, subject to Terms and Conditions for Electronic Documents at www.sgs.com/terms_e-document.htm. Attention is drawn to the limitation of liability, indemnification and jurisdiction issues defined therein. Any holder of this document is advised that information contained hereon reflects the Company's findings at the time of its intervention only and within the limits of Client's instructions, if any. The Company's sole responsibility is to its Client and this document does not exonerate parties to a transaction from exercising all their rights and obligations under the transaction documents. This document cannot be reproduced except in full, without prior written approval of the Company. Any unauthorized alteration, forgery or falsification of the content or appearance of this document is unlawful and offenders may be prosecuted to the fullest extent of the law. Unless otherwise stated the results shown in this test report refer only to the sample(s) tested and such sample(s) are retained for 90 days only."

6.4 20dB Bandwidth

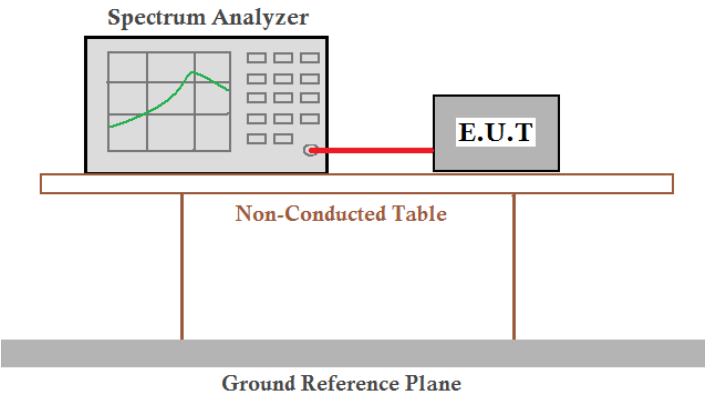
Test Requirement:	47 CFR Part 15C Section 15.215
Test Method:	ANSI C63.10:2013 Clause 6.9
Test Setup:	
Instruments Used:	Refer to section 5.10 for details
Test mode:	Transmitting mode
Limit:	Within the band 2400MHz-2483.5MHz
Test Results:	Pass

Measurement Data

Test channel	20dB bandwidth (MHz)	Results
Lowest	1.119	Pass
Middle	1.106	Pass
Highest	1.112	Pass



Test plot as follows:

Test channel:	Lowest
---------------	--------

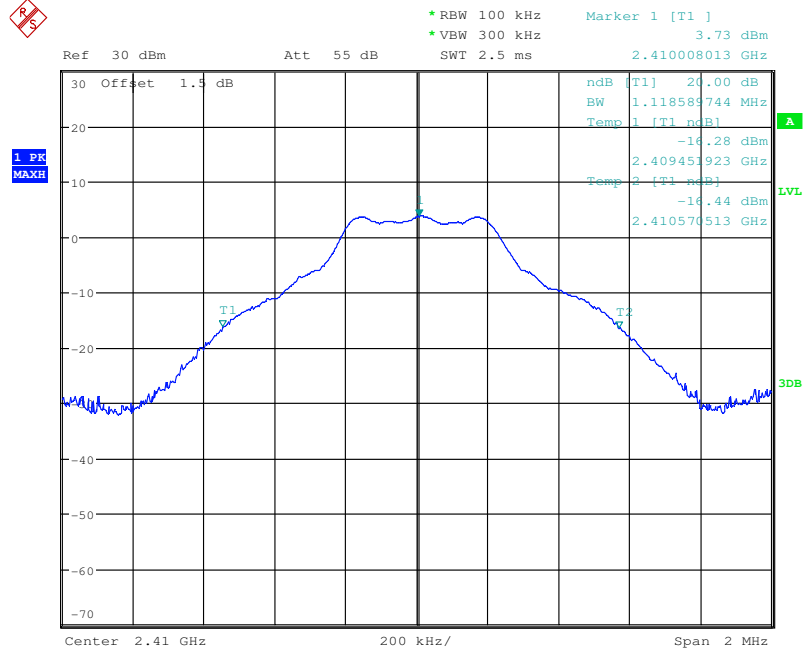

Test channel:	Middle
---------------	--------

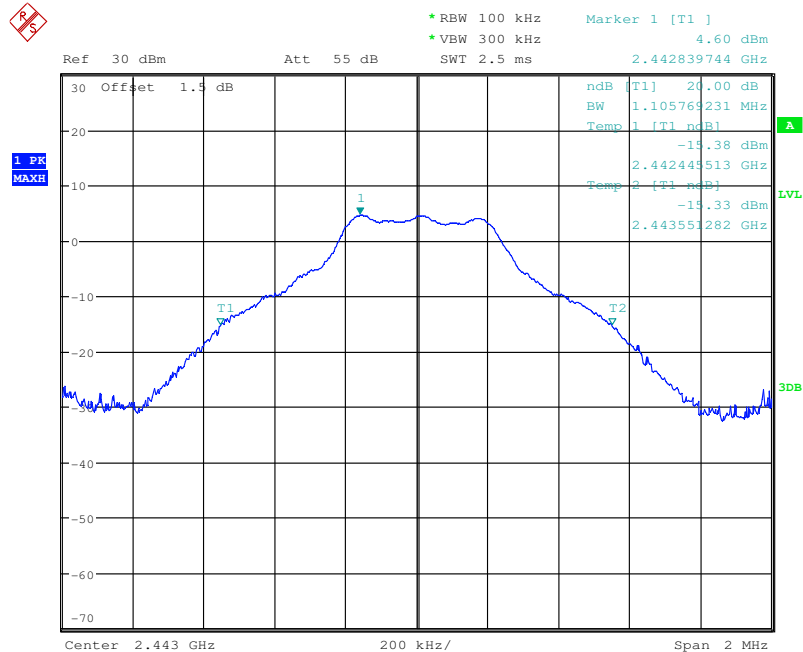

"This document is issued by the Company subject to its General Conditions of Service printed overleaf, available on request or accessible at www.sgs.com/terms_and_conditions.htm and, for electronic format documents, subject to Terms and Conditions for Electronic Documents at www.sgs.com/terms_e-document.htm. Attention is drawn to the limitation of liability, indemnification and jurisdiction issues defined therein. Any holder of this document is advised that information contained hereon reflects the Company's findings at the time of its intervention only and within the limits of Client's instructions, if any. The Company's sole responsibility is to its Client and this document does not exonerate parties to a transaction from exercising all their rights and obligations under the transaction documents. This document cannot be reproduced except in full, without prior written approval of the Company. Any unauthorized alteration, forgery or falsification of the content or appearance of this document is unlawful and offenders may be prosecuted to the fullest extent of the law. Unless otherwise stated the results shown in this test report refer only to the sample(s) tested and such sample(s) are retained for 90 days only."



Test channel: Highest

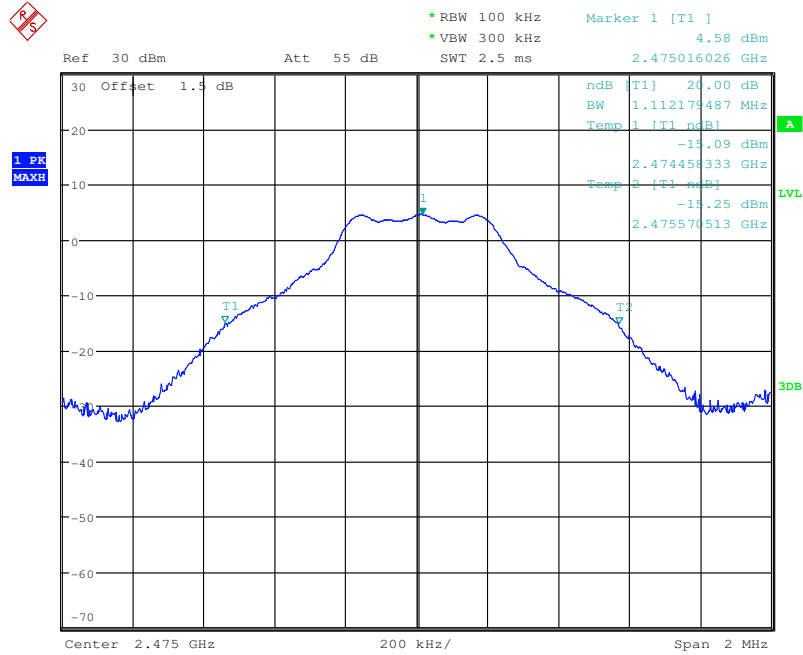

"This document is issued by the Company subject to its General Conditions of Service printed overleaf, available on request or accessible at www.sgs.com/terms_and_conditions.htm and, for electronic format documents, subject to Terms and Conditions for Electronic Documents at www.sgs.com/terms_e-document.htm. Attention is drawn to the limitation of liability, indemnification and jurisdiction issues defined therein. Any holder of this document is advised that information contained hereon reflects the Company's findings at the time of its intervention only and within the limits of Client's instructions, if any. The Company's sole responsibility is to its Client and this document does not exonerate parties to a transaction from exercising all their rights and obligations under the transaction documents. This document cannot be reproduced except in full, without prior written approval of the Company. Any unauthorized alteration, forgery or falsification of the content or appearance of this document is unlawful and offenders may be prosecuted to the fullest extent of the law. Unless otherwise stated the results shown in this test report refer only to the sample(s) tested and such sample(s) are retained for 90 days only."

7 Photographs

Test model No.: WM051-A

7.1 Radiated Emission Test Setup

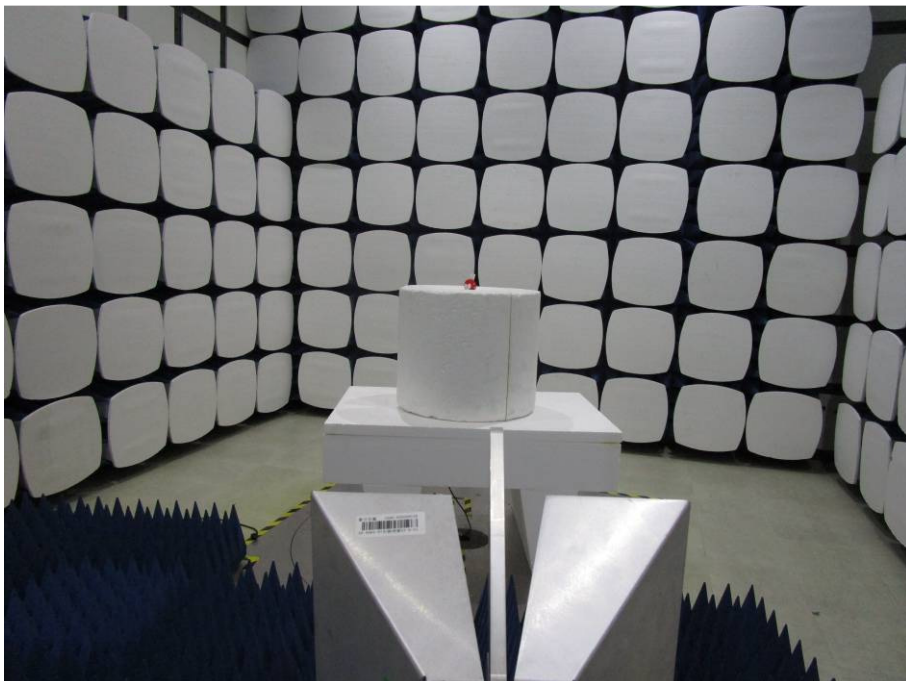
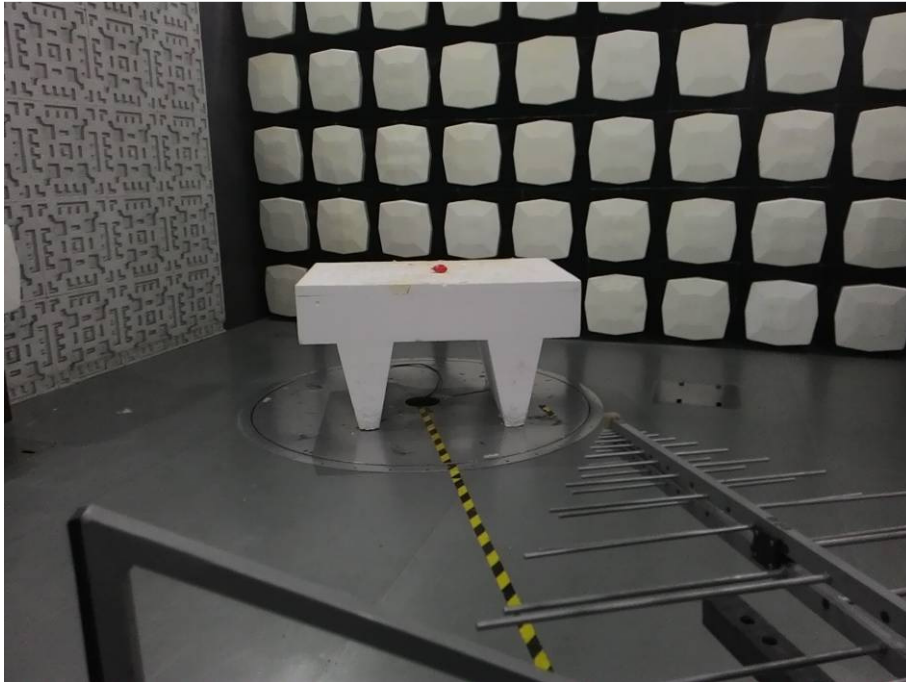



7.2 EUT Constructional Details

Refer to Appendix A - Photographs of EUT Constructional Details for SZEM1605003882CR.