

Industrial Internet Innovation Center (Shanghai) Co.,Ltd.

SRD TEST REPORT

PRODUCT	Smart counter scale
BRAND	SUNMI
MODEL	ACS-F2521,ACS-F2522,ACS-F2523
APPLICANT	Shanghai Sunmi Technology Co.,Ltd.
FCC ID	2AH25S2CC
IC	22621-S2CC
ISSUE DATE	March 1, 2024
STANDARD(S)	FCC Part15C, RSS-247 Issue 3, RSS-Gen Issue 5

Prepared by: *Tao Lingyan*

Reviewed by: *Yang Fan*

Approved by: *Zhang Min*







CAUTION:

This report shall not be reproduced except in full without the written permission of the test laboratory and shall not be quoted out of context.

CONTENTS

1. SUMMARY OF TEST REPORT	3
1.1 TEST STANDARD(S)	3
1.2 REFERENCE DOCUMENTS	3
1.3 SUMMARY OF TEST RESULTS	3
1.4 DATA PROVIDED BY APPLICANT	4
2. GENERAL INFORMATION OF THE LABORATORY	5
2.1 TESTING LABORATORY	5
2.2 LABORATORY ENVIRONMENTAL REQUIREMENTS	5
2.3 PROJECT INFORMATION	5
3. GENERAL INFORMATION OF THE CUSTOMER	6
3.1 APPLICANT	6
3.2 MANUFACTURER	6
4. GENERAL INFORMATION OF THE PRODUCT	7
4.1 PRODUCT DESCRIPTION FOR EQUIPMENT UNDER TEST	7
4.2 INTERNAL IDENTIFICATION OF AE USED DURING THE TEST	7
4.3 ADDITIONAL INFORMATION	8
5. TEST CONFIGURATION INFORMATION	9
5.1 LABORATORY ENVIRONMENTAL CONDITIONS	9
5.2 TEST EQUIPMENTS UTILIZED	9
5.3 MEASUREMENT UNCERTAINTY	11
6 TEST RESULTS	13
6.1 PEAK OUTPUT POWER-CONDUCTED	13
6.2 FREQUENCY BAND EDGES-CONDUCTED	16
6.3 CONDUCTED EMISSION	19
6.4 RADIATED EMISSION	25
6.5 TIME OF OCCUPANCY (DWELL TIME)	49
6.6 20DB BANDWIDTH	52
6.7 99% OCCUPIED BANDWIDTH	55
6.8 CARRIER FREQUENCY SEPARATION	58
6.9 NUMBER OF HOPPING CHANNELS	60
6.10 AC POWERLINE CONDUCTED EMISSION	62
ANNEX A: REVISED HISTORY	65
ANNEX B: ACCREDITATION CERTIFICATE	66

1. Summary of Test Report

1.1 Test Standard(s)

No.	Test Standard	Title	Version
1	FCC Part15C	FCC CFR 47, Part 15, Subpart C: 15.205 Restricted bands of operation; 15.209 Radiated emission limits, general requirements; 15.247 Operation within the bands 902-928MHz, 2400-2483.5MHz, and 5725-5850MHz.	--
2	RSS-247 Issue 3	Digital Transmission Systems (DTSs), Frequency Hopping Systems (FHSs) and Licence-Exempt Local Area Network (LE-LAN) Devices	2023
3	RSS-Gen Issue 5	General Requirements for Compliance of Radio Apparatus	2021

1.2 Reference Documents

No.	Test Standard	Title	Version
1	ANSI C63.10	American National Standard of Procedures for Compliance Testing of Unlicensed Wireless Devices	2013
2	KDB 558074 D01 15.247 Meas Guidance v05r02	Guidance for Performing Compliance Measurements on Frequency Hopping Spread Spectrum systems (DSS) Operating Under §15.247	--

Note: KDB 558074 D01 15.247 Meas Guidance v05r02 is not A2LA certified.

1.3 Summary of Test Results

No.	Measurement Items	FCC Rules	IC Rules	Verdict
1	Maximum Peak Output Power	15.247(b)	RSS-247 5.4	Pass
2	20dB Occupied Bandwidth	15.247(a)	RSS-247 5.1	Pass
3	99% Occupied Bandwidth	15.247(a)	RSS-GEN 6.7	Pass
4	Band Edges Compliance	15.247 (d)	RSS-247 5.5	Pass
5	Time Of Occupancy (Dwell Time)	15.247(a)	RSS-247 5.1	Pass
6	Carrier Frequency Separation	15.247(a)	RSS-247 5.1	Pass
7	Number Of Hopping Channels	15.247(a)	RSS-247 5.1	Pass
8	Transmitter Spurious Emission-Conducted	15.247(d)	RSS-247 5.5	Pass
9	Transmitter Spurious Emission-Radiated	15.247,15.209,15.205	RSS-GEN 8.9, 8.10	Pass
10	AC Powerline Conducted Emission	15.207	RSS-GEN 8.8	Pass
11	Antenna requirement	15.203/15.247(c)	RSS Gen 6.8, RSS-247 5.4	Pass ^{Note 2}

Note 1:

The ACS-F2521,ACS-F2522,ACS-F2523 manufactured by Shanghai Sunmi Technology Co.,Ltd. is a new products for testing.

There are three configurations S03aa&S08aa (Mainly Supply), S16aa (Secondary Supply) and S12(Thirdly supply) in this project. We mainly tested the S03aa&S08aa (Mainly Supply), and the S16aa (Secondary Supply) and S12(Thirdly supply) tested the worst mode of the mainly supply, and recorded the test results of the worst mode respectively in the report.

The description of the differences between S03aa&S08aa (Mainly Supply), S16aa (Secondary Supply) and S12(Thirdly supply) are as follows:

Model	Screen size
ACS-F2521: S16aa (Secondary Supply)	15.6" screen+10.1" screen
ACS-F2522: S08aa (Mainly Supply)	15.6" screen+15.6" screen
ACS-F2523: S12aa (Thirdly Supply)	15.6" screen

Industrial Internet Innovation Center (Shanghai) Co., Ltd. only performed test cases which identified with Pass/Fail/Inc result in section 1.3.

Industrial Internet Innovation Center (Shanghai) Co., Ltd. has verified that the compliance of the tested device specified in section 4 of this test report is successfully evaluated according to the procedure and test methods as defined in type certification requirement listed in section 1 of this test report.

Note 2:

Bluetooth used a FPC antenna with max Gain 1.58dBi that complied with 15.203 Requirements.

Note:

- a. All the test data for each data were verified, but only the worst case was reported.
- b. The GFSK, $\pi/4$ DQPSK and 8DPSK were set in DH5 for GFSK, 2-DH5 for $\pi/4$ DQPSK, 3-DH5 for 8DPSK.

1.4 Data Provided by Applicant

No.	Item(s)	Data
1	Antenna gain of EUT	1.58 dBi

Note: The data of antenna gain is provided by the Antenna specification may affect the validity of the test results in this report, and the impact and consequences of this shall be undertaken by the customer.

2. General Information of The Laboratory

2.1 Testing Laboratory

Lab Name	Industrial Internet Innovation Center (Shanghai) Co.,Ltd.
Address	Building 4, No. 766, Jingang Road, Pudong, Shanghai, China
Telephone	021-68866880
FCC Registration No.	708870
FCC Designation No.	CN1364
IC Designation No.	10766A
CAB identifier	CN0067

2.2 Laboratory Environmental Requirements

Temperature	15°C~35°C
Relative Humidity	25%RH~75%RH
Atmospheric Pressure	86kPa~106kPa

2.3 Project Information

Project Manager	Gao Hongning
Test Date	January 02, 2024 to February 26, 2024

3. General Information of The Customer

3.1 Applicant

Company	Shanghai Sunmi Technology Co.,Ltd.
Address	Room 505,No.388,Song Hu Road,Yang Pu District,Shanghai,China
Telephone	+86 17302160204

3.2 Manufacturer

Company	Shanghai Sunmi Technology Co.,Ltd.
Address	Room 505,No.388,Song Hu Road,Yang Pu District,Shanghai,China
Telephone	+86 17302160204

4. General Information of The Product

4.1 Product Description for Equipment under Test

Product Name	Smart counter scale
Model name	ACS-F2521,ACS-F2522,ACS-F2523
Date of Receipt	S03aa/S08aa/S16aa/S12aa:February 02, 2024
EUT ID*	S03aa/S08aa/S16aa/S12aa
SN/IMEI	NA
Supported Radio Technology and Bands	BT 4.2 BR/EDR/BLE WLAN 802.11b/g/n WLAN 802.11a/n/ac
Hardware Version	RK3568_MB_V2.0
Software Version	3.0.11
FCC ID	2AH25S2CC
IC	22621-S2CC
NOTE1: EUT ID is the internal identification code of the laboratory.	
NOTE2: Samples in the test report are provided by the customer. The test results are only applicable to the samples received by the laboratory.	

4.2 Internal Identification of AE used during the test

AE ID*	Description	Model	SN/Remark
CB04	Adapter	CYSE65-240250	Jiangsu Chenyang Electron Co., Ltd. 24V,2.5A
UB04	AC Cable	N/A	N/A
AE1	Notebook PC	DELL Latitude E6510	N/A
AE2	LAN Cable	N/A	N/A
AE3	Keyboard	KB212-B	CN-0Y88XT-65890-12I-005Q-A00
AE4	Mouse	MS111-P	CN-011D3V-71581-19J-1A64
AE5	Earphone	N/A	N/A
AE6	Micro SD card	Kingston SDC4/4GB 77	N/A
AE7	Cash Box	NC020	N/A
AE8	Telephone	HA8000(28) P/T S	N/A

AE9	U disk	Kingston DTSE9 16GB	N/A
AE10	U disk	Kingston DTSE9 16GB	N/A
AE11	USB Cable	N/A	N/A
AE12	Object of weight	N/A	N/A
NOTE: AE ID is the internal identification code of the laboratory.			

4.3 Additional Information

Bluetooth Frequency	2402MHz-2480MHz
Bluetooth Channel	Ch0-78
Bluetooth Modulation	GFSK; $\pi/4$ DQPSK; 8DPSK

Test frequency list:

GFSK	Channel	0	39	78
	Freq. (MHz)	2402	2441	2480
$\pi/4$ DQPSK	Channel	0	39	78
	Freq. (MHz)	2402	2441	2480
8DPSK	Channel	0	39	78
	Freq. (MHz)	2402	2441	2480

Note: This report is for BT only.

5. Test Configuration Information

5.1 Laboratory Environmental Conditions

5.1.1 Permanent Facilities

Relative Humidity	Min. = 45 %, Max. = 55 %		
Atmospheric Pressure	101kPa		
Temperature	Normal	Minimum	Maximum
	25°C	-10°C	40°C
Working Voltage of EUT	Normal	Minimum	Maximum
	24V	22.8V	25.2V

5.2 Test Equipments Utilized

5.2.1 Conducted Test System

No.	Name	Model	S/N	SW Version	HW Version	Manufacturer	Cal. Date	Cal. Interval
1	Test Software	TS1120	10727	V3.2.22	N/A	Tonsce nd	N/A	N/A
2	Automatic control unit	JS0806-2	2218060623	N/A	N/A	Tonsce nd	2023-05-06	1 Year
3	Wireless communication comprehensive tester	CMW500	164865	V3.8.12	N/A	R&S	2023-07-26	1 Year
4	Spectrum Analyzer	FSQ40	200063	V4.75	N/A	R&S	2023-10-16	1 Year
5	Analog Signal Generator	SMF	104770	V3.0.13.0-2.20.530.15.4	N/A	R&S	2023-10-16	1 year
6	Vector Signal Generator	SMCV100B	103691	V5.00.122.24	N/A	R&S	2023-07-27	1 Year
7	Programmable Power Supply	Keithley 2303	4039070	N/A	N/A	Keithley	2023-06-23	1 Year
8	Temperature box	B-TF-107C	BTF107C-201804107	N/A	N/A	Boyi	2023-06-28	1 Year
9	Network test unit AP	GT-AXE11000	N2IG0X401637KWF	V3.0.0.4.386_45940	N/A	ASUS	N/A	N/A
10	Vector Signal Generator	SMBV100A	257904	V4.15.125.49	N/A	R&S	2023-10-16	1 Year

5.2.2 Radiated Emission Test System

No	Name	Model	S/N	SW Version	HW Version	Manufacturer	Cal. Date	Cal. Interval
1	Universal Radio Communication Tester	CMU200	123126	V5.2.1	B12	R&S	2023-10-16	1 Year
2	Universal Radio Communication Tester	CMW500	104178	V3.7.20	1206.0600.00	R&S	2023-10-16	1 Year
3	EMI Test Receiver	ESU40	100307	V5.1-24-3	01	R&S	2022-12-19	1 Year
4	TRILOG Broadband Antenna	VULB9163	01345	N/A	N/A	Schwarzbeck	2023-03-23	1 Year
5	Double-ridged Waveguide Antenna	ETS-3117	00135890	N/A	N/A	ETS	2022-03-09	2 Years
6	EMI Test Software	EMC32 V10.35.02	N/A	N/A	N/A	R&S	N/A	N/A
7	Horn Antenna	3160-09	LM6321	N/A	N/A	R&S	2023-07-16	1 Year
8	Horn Antenna	3160-10	LM5942	N/A	N/A	R&S	2023-07-16	1 Year
9	Loop Antenna	AL-130R	121083	N/A	N/A	COM-POWER	2023-9-13	1 Year
10	Preamplifier	SCU08F1	8320024	N/A	N/A	R&S	2023-10-16	1 Year
11	Preamplifier	SCU18	10155	N/A	N/A	R&S	2023-10-16	1 Year
12	Preamplifier	SCU26	10025	N/A	N/A	R&S	2023-10-16	1 Year
13	Preamplifier	SCU40	10020	N/A	N/A	R&S	2023-10-16	1 Year
14	2-Line V-Network	ENV216	101380	N/A	N/A	R&S	2023-12-19	1 Year
15	EMI Test Software	EMC32 V10.35.02	N/A	N/A	N/A	R&S	N/A	N/A
16	Test Receiver	ESCI	101235	V5.1-24-3	0	R&S	2023-12-19	1 Year

5.2.3 Test Environment

Shielding Room1 (6.0 meters×3.0 meters×2.7 meters) did not exceed following limits along the conducted RF performance testing:

Temperature	Min. = 15 °C, Max. = 35 °C
Relative humidity	Min. = 20 %, Max. = 75 %
Shielding effectiveness	> 100 dB
Ground system resistance	< 0.5 Ω
Temperature	Min. = 15 °C, Max. = 35 °C

Control room did not exceed following limits along the EMC testing:

Temperature	Min. = 15 °C, Max. = 35 °C
Relative humidity	Min. = 30 %, Max. = 60 %
Shielding effectiveness	> 100 dB
Electrical insulation	> 10 kΩ
Ground system resistance	< 0.5 Ω

Fully-anechoic chamber1 (9.8 meters×6.7 meters×6.7 meters) did not exceed following limits along the EMC testing:

Temperature	Min. = 15 °C, Max. = 35 °C
Relative humidity	Min. = 25 %, Max. = 75 %
Shielding effectiveness	> 100 dB
Electrical insulation	> 10 kΩ
Ground system resistance	< 0.5 Ω
VSWR	Between 0 and 6 dB, from 1GHz to 18GHz
Site Attenuation Deviation	Between -4 and 4 dB, 30MHz to 1GHz

5.3 Measurement Uncertainty

Measurement Uncertainty of Conduction test

Measurement Items	Range	Confidence Level	Calculated Uncertainty
20dB Emission Bandwidth	2400–2483.5MHz	95%	±1.9%
Carrier Frequency Separation	2400–2483.5MHz	95%	±1.9%
Maximum Power Spectral Density Level	2400–2483.5MHz	95%	±0.98 dB
Number of Hopping Channel	2400–2483.5MHz	95%	±1.9%
Time of Occupancy	2400–2483.5MHz	95%	±0.11%

Max Peak Conducted Output Power	2400–2483.5MHz	95%	±0.98 dB
Band-edge Spurious Emission	2400–2483.5MHz	95%	±1.21dB
Conducted RF Spurious Emission	9kHz-40GHz	95%	9kHz-7GHz:±1.21dB 7GHz-40GHz: ±3.31dB

Measurement Uncertainty of Radiation test

Measurement Items	Uncertainty(dB)
Radiated Emission 30MHz-1000MHz	±5.10
Radiated Emission 1000MHz-18000MHz	±5.66
Radiated Emission 18000MHz-40000MHz	±5.22
AC Powerline Conducted Emission	±4.38

Note: This uncertainty represents an expanded uncertainty expressed at approximately the 95% confidence level using a coverage factor of k=2.

6 Test Results

6.1 Peak Output Power-Conducted

6.1.1 Measurement Limit

Standard	Conducted Limit (dBm)	EIRP Limit(dBm)
FCC 47 Part 15.247(b)	GFSK: ≤ 30 , pi/4-DQPSK and 8DPSK ≤ 20.97	N/A
RSS-247 5.4(b)	GFSK: ≤ 30 , pi/4-DQPSK and 8DPSK ≤ 20.97	≤ 36

6.1.2 Test Condition

Hopping Mode	RBW	VBW	Span	Sweeptime
Hopping OFF	3MHz	10MHz	9MHz	Auto

6.1.3 Test Procedure

The measurement is according to ANSI C63.10 clause 7.8.5.

1. The output power of EUT was connected to the spectrum analyzer by cable and divide. The path loss was compensated to the results for each measurement.
2. Enable EUT transmitter maximum power continuously.
3. Use the following spectrum analyzer settings:
 - a) Span: Approximately five times the 20 dB bandwidth, centered on a hopping channel.
 - b) RBW > 20 dB bandwidth of the emission being measured.
 - c) VBW \geq RBW.
 - d) Sweep: Auto.
 - e) Detector function: Peak.
 - f) Trace: Max hold.
4. Allow trace to stabilize.
5. Use the marker-to-peak function to set the marker to the peak of the emission.
6. The indicated level is the peak output power, after any corrections for external attenuators and cables.
7. Record the results.

6.1.4 Test setup

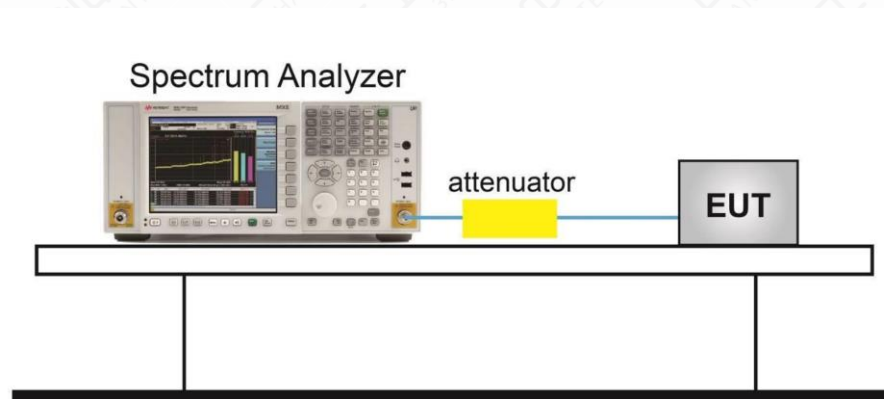

6.1.5 Measurement Results

Test Mode	Antenna	Frequency[MHz]	Conducted Peak Power[dBm]	Conducted Limit[dBm]	EIRP[dBm]	EIRP Limit[dBm]	Verdict
DH5	Ant1	2402	7.37	≤30	8.95	≤36	PASS
DH5	Ant1	2441	8.11	≤30	9.69	≤36	PASS
DH5	Ant1	2480	8.19	≤30	9.77	≤36	PASS
2DH5	Ant1	2402	7.29	≤20.97	8.87	≤36	PASS
2DH5	Ant1	2441	8.09	≤20.97	9.67	≤36	PASS
2DH5	Ant1	2480	8.20	≤20.97	9.78	≤36	PASS
3DH5	Ant1	2402	7.57	≤20.97	9.15	≤36	PASS
3DH5	Ant1	2441	8.35	≤20.97	9.93	≤36	PASS
3DH5	Ant1	2480	8.46	≤20.97	10.04	≤36	PASS

Test Graphs

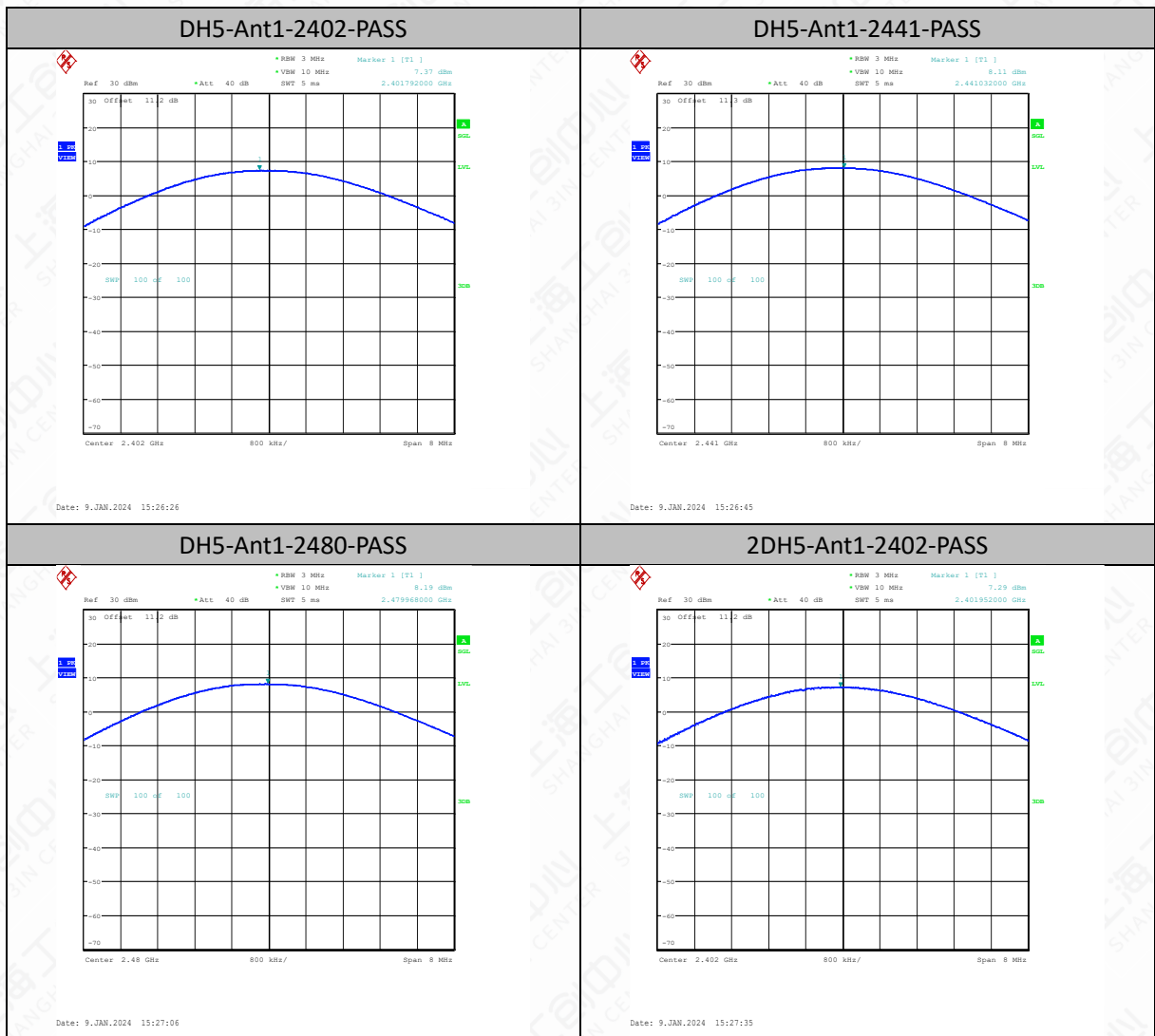

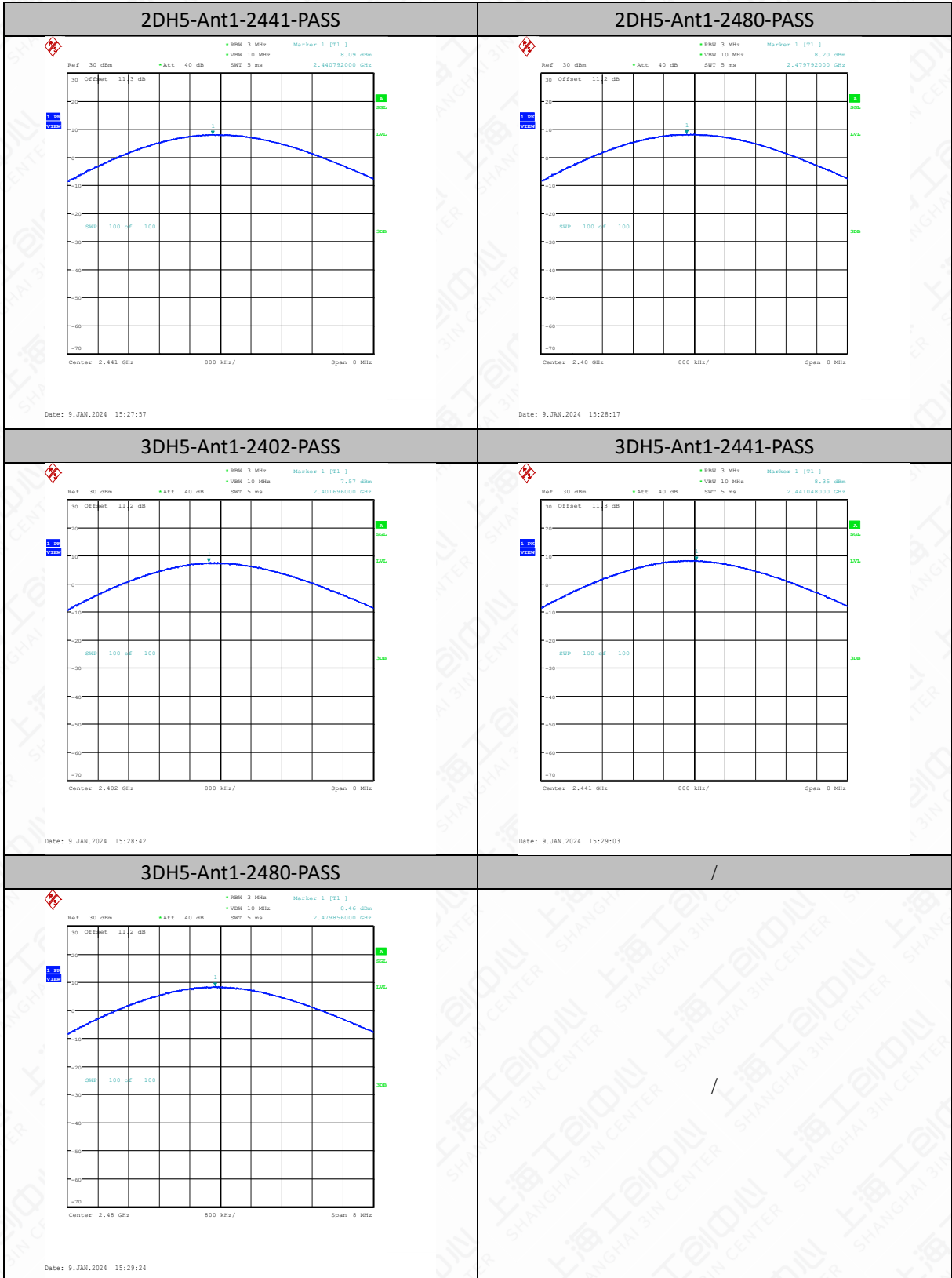

6.2 Frequency Band Edges-Conducted

6.2.1 Measurement Limit

Standard	Limit(dBc)
FCC 47 CFR Part 15.247(d)	>20
RSS-247 5.5	>20

6.2.2 Test procedures

The measurement is according to ANSI C63.10 clause 7.8.6.

1. Connect the EUT to spectrum analyzer.
2. Set RBW=100KHz, VBW=300KHz, span more than 1.5 times channel bandwidth (2MHz).
3. Detector =peak, sweep time=auto couple, trace mode=max hold.Allow sweep to continue until the trace stabilizes.

6.2.3 Test setup

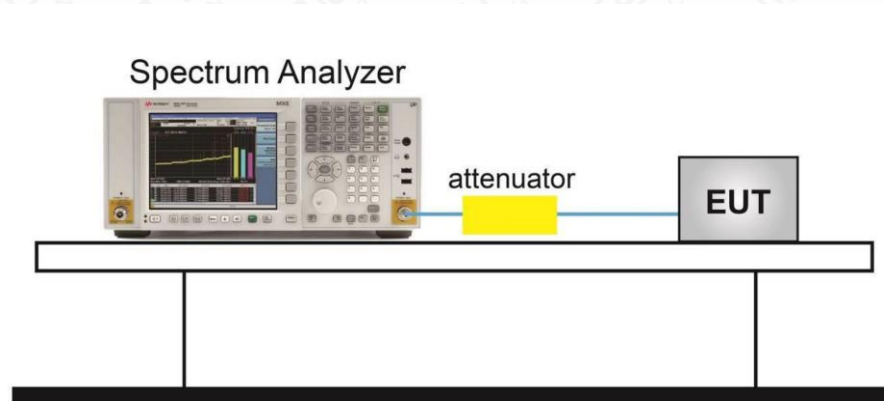

6.2.4 Measurement Result

TestMode	Antenna	ChName	Frequency[MHz]	RefLevel [dBm]	Result [dBm]	Limit [dBm]	Verdict
DH5	Ant1	Low	2402	5.23	-46.46	≤-14.77	PASS
DH5	Ant1	High	2480	4.01	-47.2	≤-15.99	PASS
DH5	Ant1	Low	Hop_2402	3.11	-44.37	≤-16.89	PASS
DH5	Ant1	High	Hop_2480	8.70	-44.08	≤-11.3	PASS
2DH5	Ant1	Low	2402	-0.64	-46.76	≤-20.64	PASS
2DH5	Ant1	High	2480	0.09	-46.15	≤-19.91	PASS
2DH5	Ant1	Low	Hop_2402	3.18	-44.11	≤-16.82	PASS
2DH5	Ant1	High	Hop_2480	4.24	-44.03	≤-15.76	PASS
3DH5	Ant1	Low	2402	-1.29	-47.06	≤-21.29	PASS
3DH5	Ant1	High	2480	-0.06	-47.1	≤-20.06	PASS
3DH5	Ant1	Low	Hop_2402	2.85	-44.66	≤-17.15	PASS
3DH5	Ant1	High	Hop_2480	3.73	-44.15	≤-16.27	PASS

Test Graphs

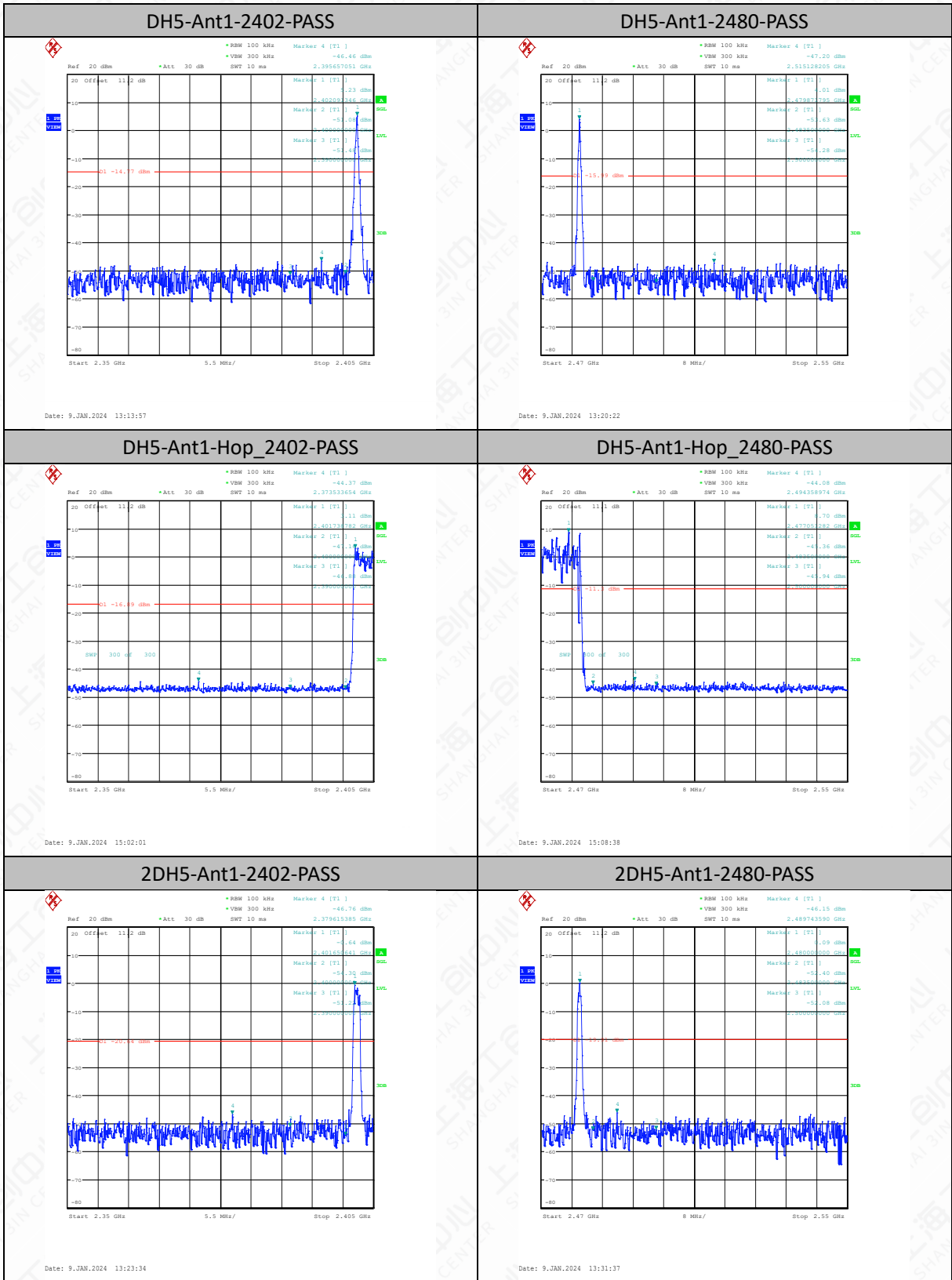

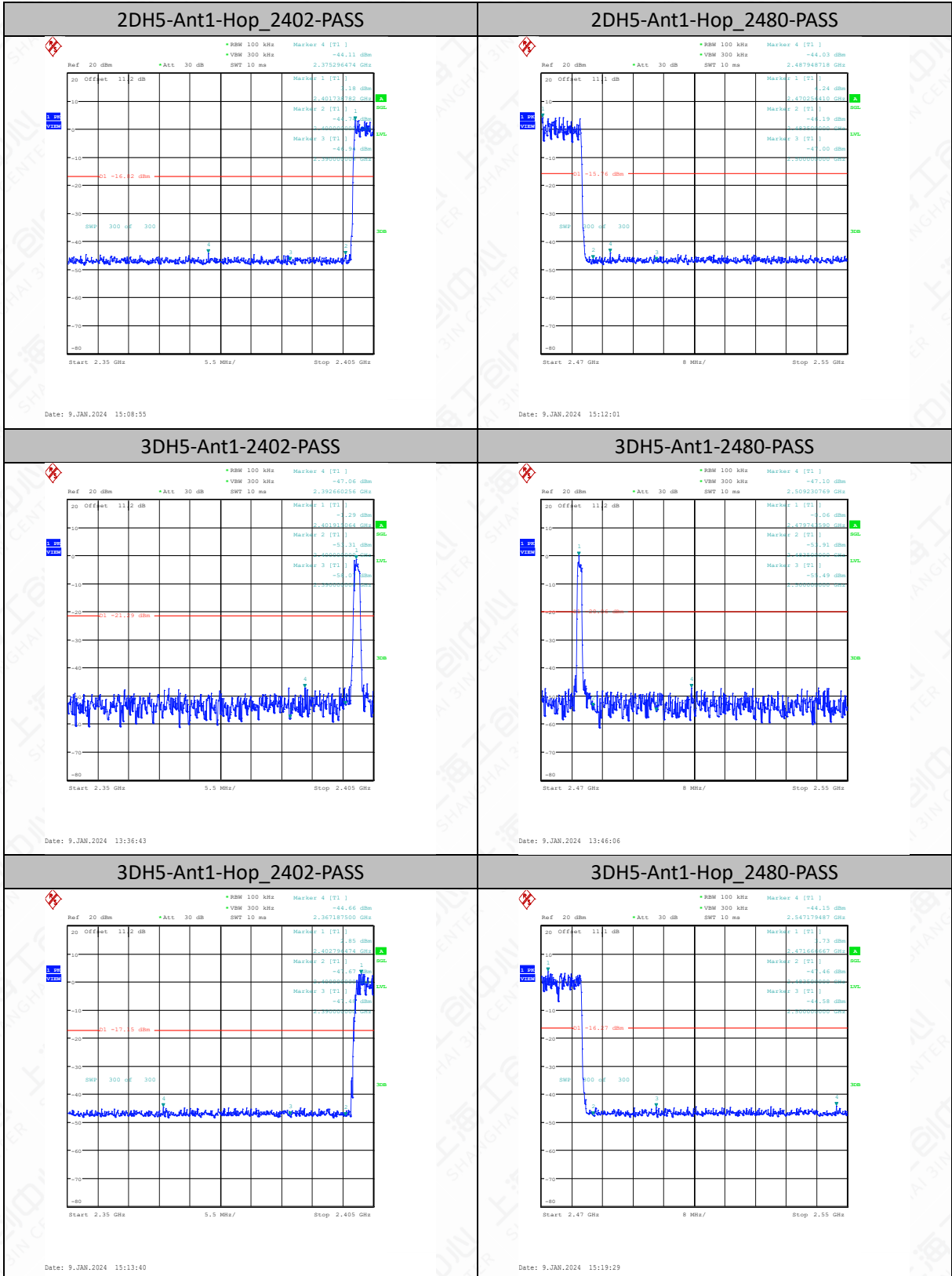

6.3 Conducted Emission

6.3.1 Measurement Limit

Standard	Limit
FCC 47 CFR Part15.247 (d)	20dB below peak output power in 100kHz bandwidth
RSS-247 5.5	20dB below peak output power in 100kHz bandwidth

6.3.2 Test procedures

The measurement is according to ANSI C63.10 clause 7.8.8.

1. Connect the EUT to spectrum analyzer.
2. Set RBW=100KHz, VBW=300KHz.
3. Detector =peak, sweep time=auto couple, trace mode=max hold

6.3.3 Test Setup

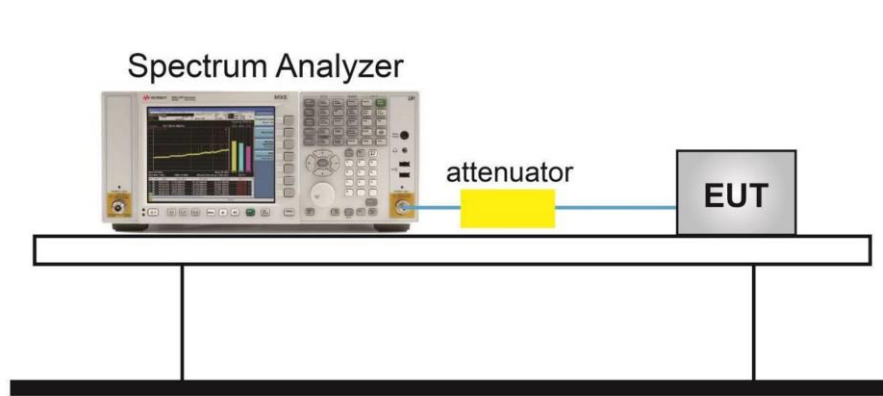

6.3.4 Measurement Results

TestMode	Antenna	Frequency[MHz]	FreqRange [MHz]	RefLevel [dBm]	Result [dBm]	Limit [dBm]	Verdict
DH5	Ant1	2402	0~Reference	6.04	6.04	---	PASS
DH5	Ant1	2402	30~1000	6.04	-53.91	≤-13.96	PASS
DH5	Ant1	2402	1000~26500	6.04	-52.08	≤-13.96	PASS
DH5	Ant1	2441	0~Reference	6.86	6.86	---	PASS
DH5	Ant1	2441	30~1000	6.86	-54.53	≤-13.14	PASS
DH5	Ant1	2441	1000~26500	6.86	-49.82	≤-13.14	PASS
DH5	Ant1	2480	0~Reference	6.79	6.79	---	PASS
DH5	Ant1	2480	30~1000	6.79	-54.22	≤-13.21	PASS
DH5	Ant1	2480	1000~26500	6.79	-51.41	≤-13.21	PASS
2DH5	Ant1	2402	0~Reference	1.79	1.79	---	PASS
2DH5	Ant1	2402	30~1000	1.79	-53.91	≤-18.21	PASS
2DH5	Ant1	2402	1000~26500	1.79	-51.79	≤-18.21	PASS
2DH5	Ant1	2441	0~Reference	2.66	2.66	---	PASS
2DH5	Ant1	2441	30~1000	2.66	-54.53	≤-17.34	PASS

2DH5	Ant1	2441	1000~26500	2.66	-51.66	≤-17.34	PASS
2DH5	Ant1	2480	0~Reference	2.83	2.83	---	PASS
2DH5	Ant1	2480	30~1000	2.83	-54.41	≤-17.17	PASS
2DH5	Ant1	2480	1000~26500	2.83	-51.66	≤-17.17	PASS
3DH5	Ant1	2402	0~Reference	1.89	1.89	---	PASS
3DH5	Ant1	2402	30~1000	1.89	-54.34	≤-18.11	PASS
3DH5	Ant1	2402	1000~26500	1.89	-52.22	≤-18.11	PASS
3DH5	Ant1	2441	0~Reference	2.80	2.80	---	PASS
3DH5	Ant1	2441	30~1000	2.80	-54.27	≤-17.2	PASS
3DH5	Ant1	2441	1000~26500	2.80	-52.19	≤-17.2	PASS
3DH5	Ant1	2480	0~Reference	2.90	2.90	---	PASS
3DH5	Ant1	2480	30~1000	2.90	-53.32	≤-17.1	PASS
3DH5	Ant1	2480	1000~26500	2.90	-52	≤-17.1	PASS

Test Graphs

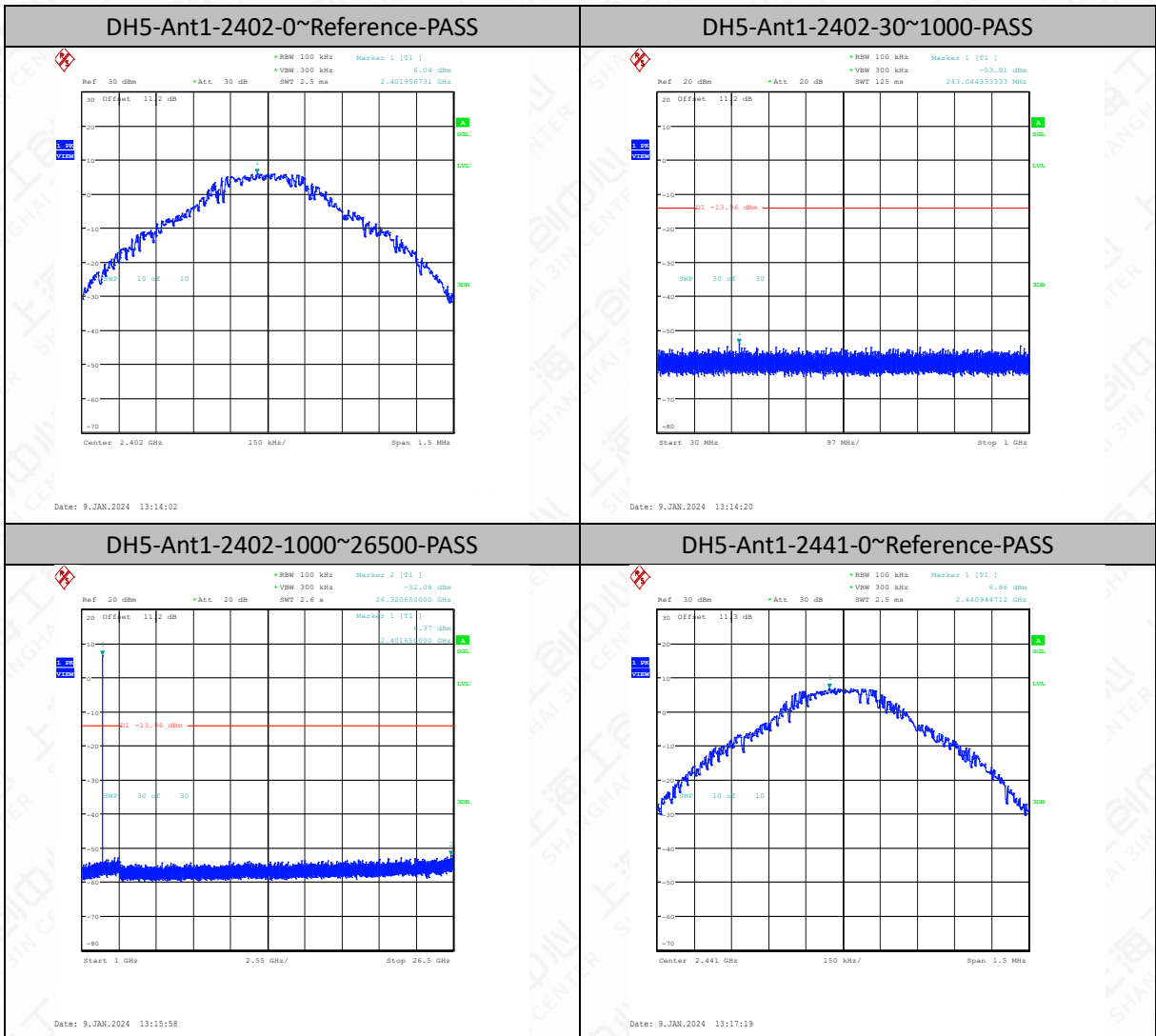

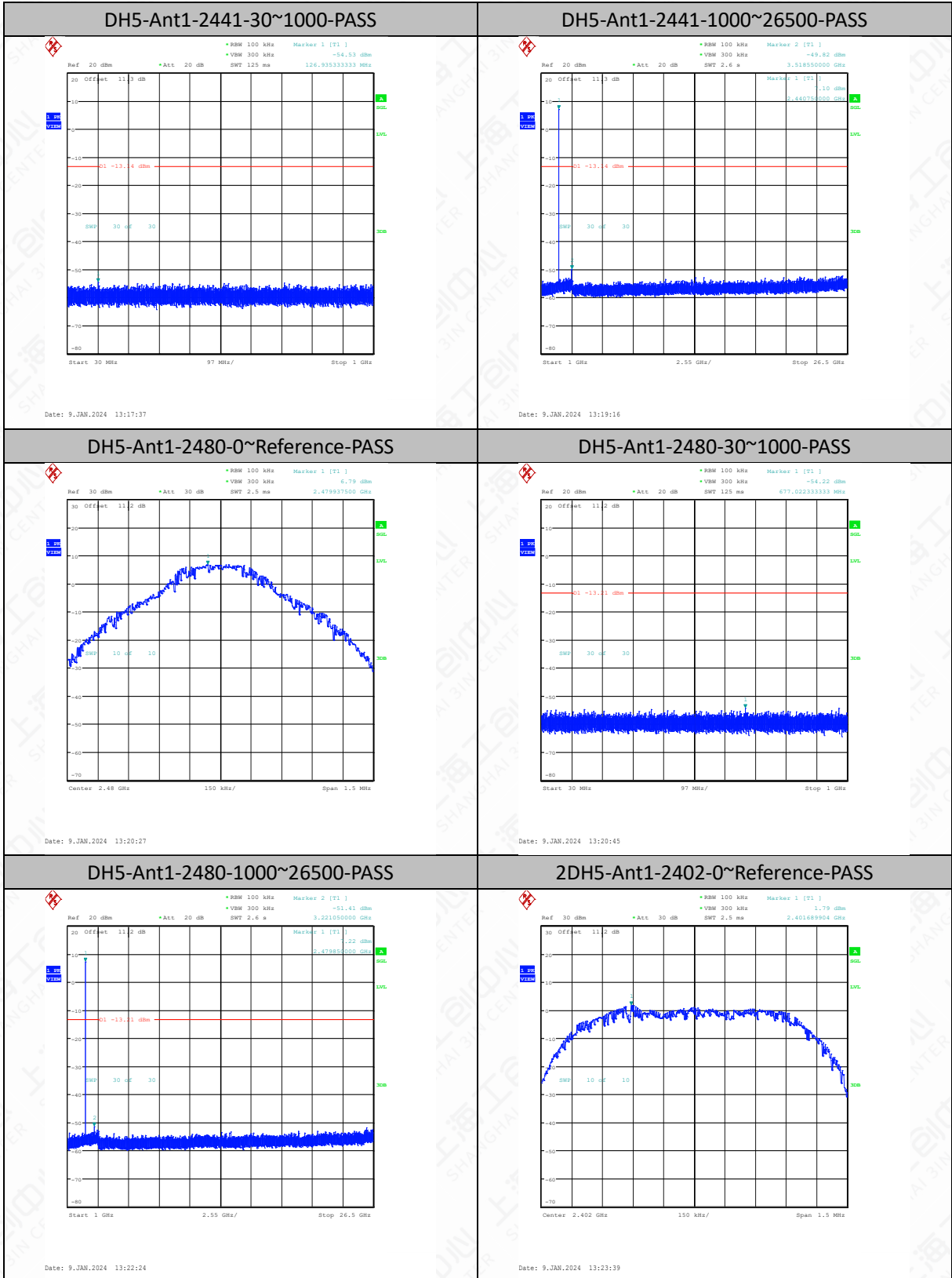

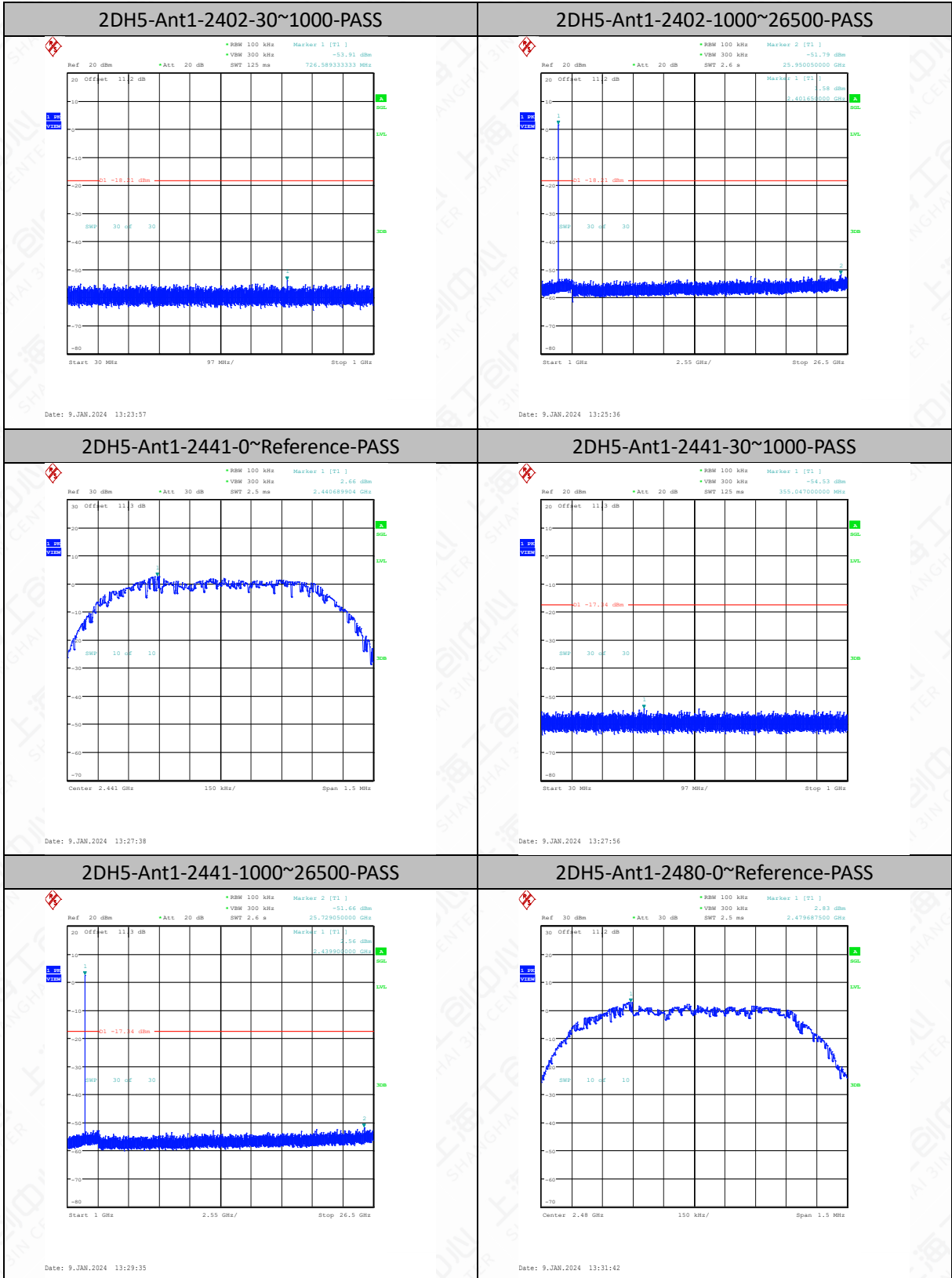

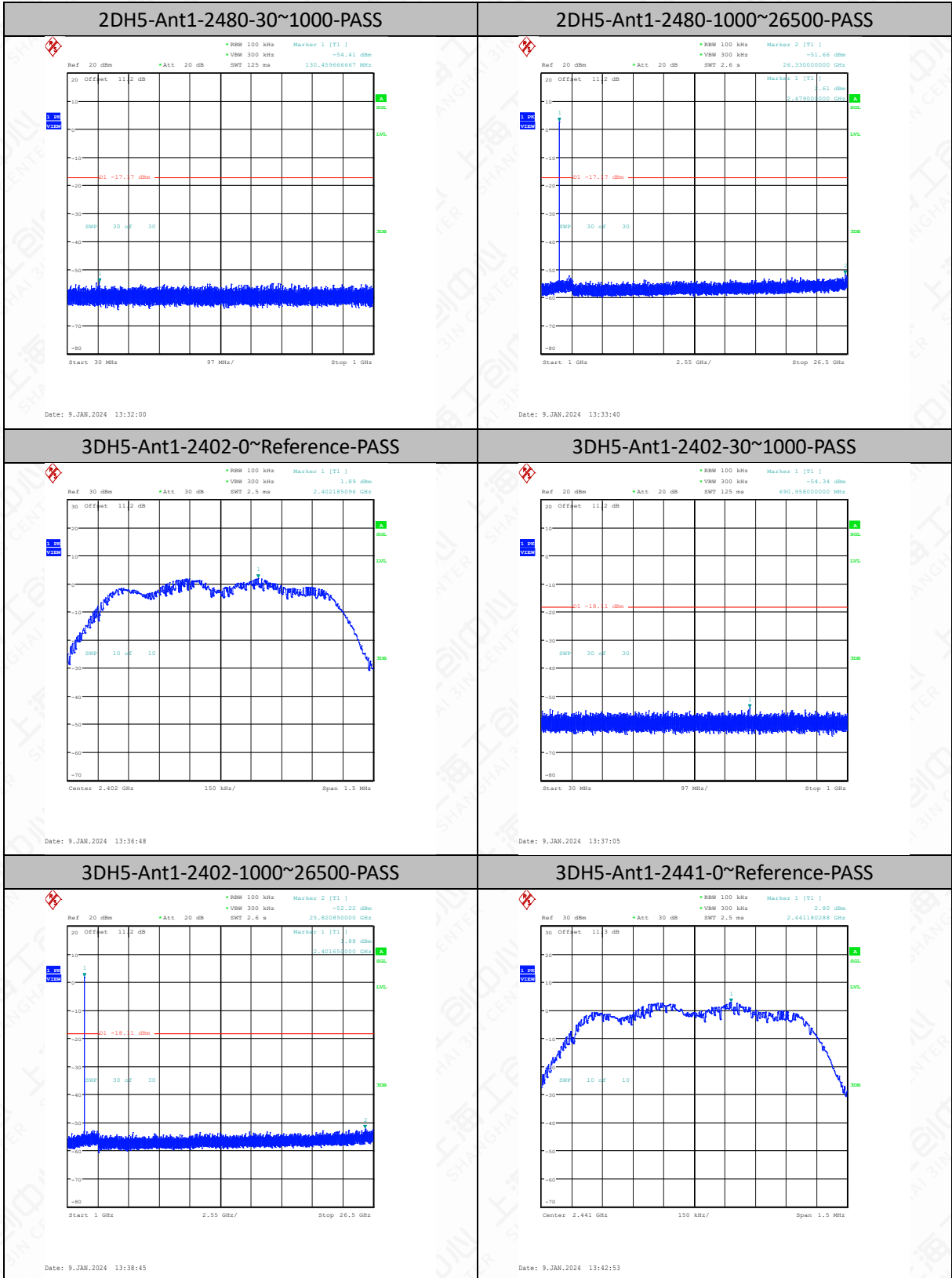

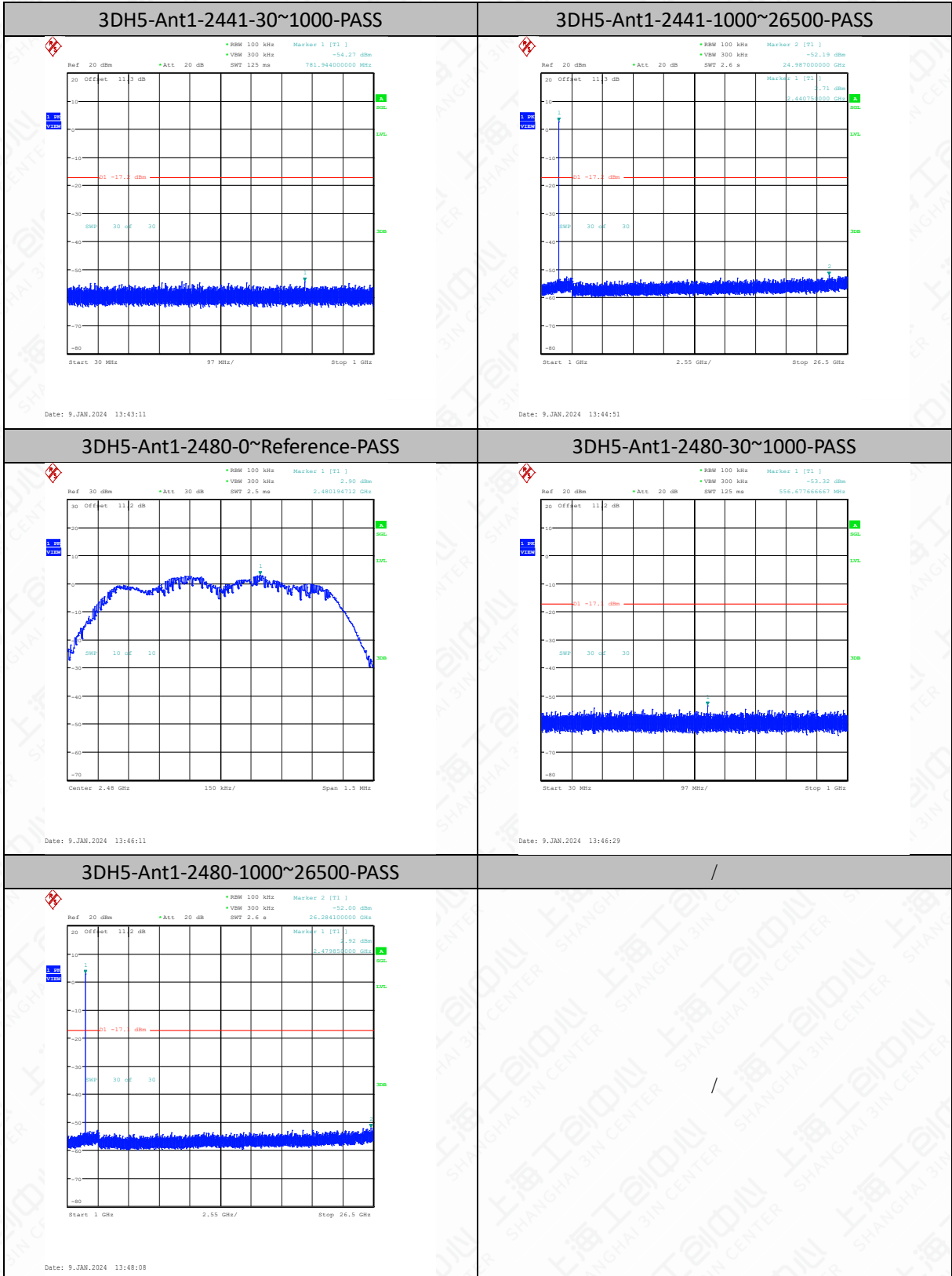

6.4 Radiated Emission

6.4.1 Measurement Limit

Standard	Limit
FCC 47 CFR Part 15.247, 15.205, 15.209	20dB below peak output power
RSS-GEN 8.9, 8.10	20dB below peak output power

In addition, radiated emissions which fall in the restricted bands, as defined in 15.205(a), must also comply with the radiated emission limits specified in 15.209(a) (see 15.205(c)).

Limit in restricted band

Frequency of emission (MHz)	Field strength (mV/m)	Field strength (dBuV/m)
0.009~0.49	2400/F (kHz)	129-94
0.49~1.705	24000/F (kHz)	74-63
1.705~30	30	70
30~88	100	40
88~216	150	43.5
216~960	200	46
Above 960	500	54

6.4.2 Test Method

Portable, small, lightweight, or modular devices that may be handheld, worn on the body, or placed on a table during operation shall be positioned on a non-conducting platform, the top of which is 80 cm above the reference ground plane. The preferred area occupied by the EUT arrangement is 1 m by 1.5 m, For emissions testing at or below 1 GHz, the table height shall be 80 cm above the reference ground plane. For emission measurements above 1 GHz, the table height shall be 1.5 m. but it may be larger or smaller to accommodate various sized EUTs. For testing purposes, ceiling- and wall-mounted devices also shall be positioned on a tabletop (see also ANSI C63.10-2013 section 6.3.4 and 6.3.5). In making any tests involving handheld, body-worn, or ceiling-mounted equipment, it is essential to recognize that the measured levels may be dependent on the orientation (attitude) of the three orthogonal axes of the EUT. Thus, exploratory tests as specified in 8.3.1 shall be carried out for various axes orientations to determine the attitude having maximum or near-maximum emission level.

The EUT was placed on a non-conductive table. The measurement antenna was placed at a distance of 3 meters from the EUT. During the tests, the antenna height and the EUT azimuth were varied in order to identify the maximum level of emissions from the EUT. This maximization process was repeated with the EUT positioned in each of its three orthogonal orientations.

Test Settings – Below 1GHz (Quasi-Peak Field Strength Measurements)

1. Set the center frequency and span to encompass frequency range to be measured.
2. Set the RBW = 100 kHz.
3. Set the VBW = 300 kHz.
4. Detector = quasi-peak.
5. Sweep time = auto couple.
6. Trace mode = max hold.

7. Trace was allowed to stabilize.

Test Settings – Above 1GHz (Peak Field Strength Measurements)

1. Set the center frequency and span to encompass frequency range to be measured.
2. Set the RBW = 1MHz.
3. Set the VBW = 3MHz.
4. Detector = peak
5. Trace mode = max hold
6. Sweep time = auto
7. Trace (RMS) averaging was performed over at least 100 traces.

Test Settings – Above 1GHz (Average Field Strength Measurements)

1. Set the center frequency and span to encompass frequency range to be measured.
2. Set the RBW = 1MHz.
3. Set the VBW = 3MHz.
4. Detector = power average (RMS).
5. Number of measurement points = 1001 (Number of points must be $\geq 2 \times \text{span} \backslash \backslash \text{RBW}$)
6. Sweep time = auto
7. Trace (RMS) averaging was performed over at least 100 traces.

Frequency of emission	RBW/VBW	Sweep Time (s)
0.009~30	9KHz/30KHz	Auto
30~1000	100KHz/300KHz	5
1000~4000	1MHz/3MHz	15
4000~18000	1MHz/3MHz	40
18000~26500	1MHz/3MHz	20

6.4.3 Test Setup

Below 30MHz Test Setup

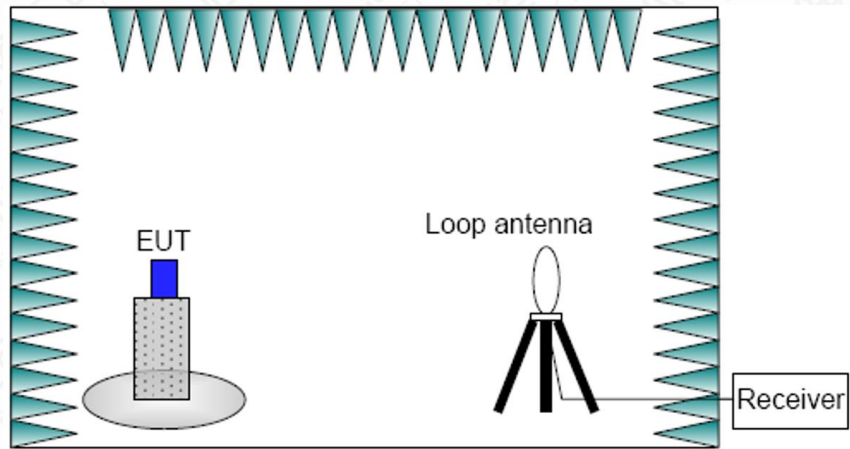

Below 1GHz Test Setup

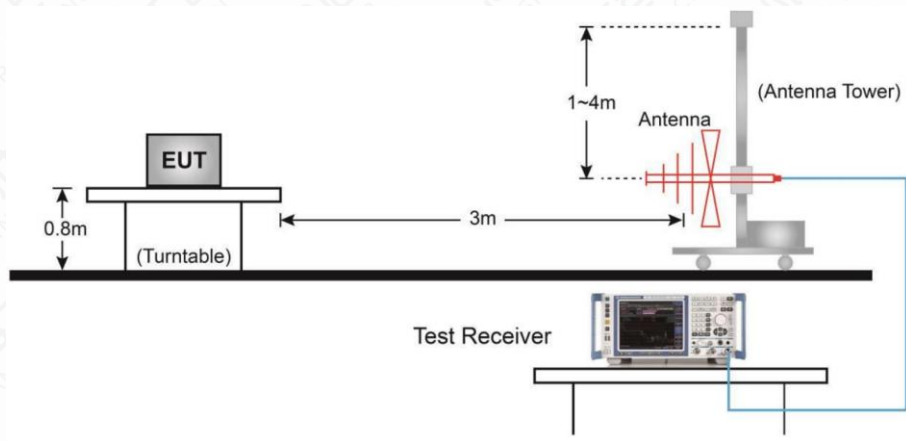

Above 1GHz Test Setup

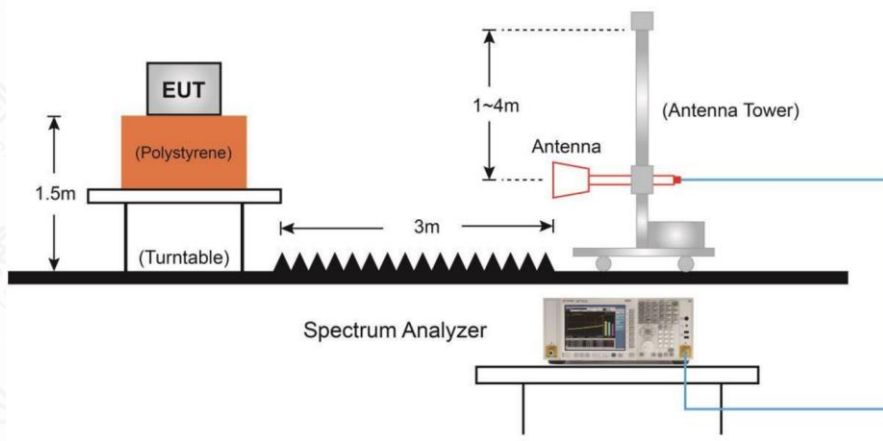

6.4.4 Measurement Results

A “reference path loss” is established and AR_{pi} is the attenuation of “reference path loss”, and including the gain of receive antenna, the gain of the preamplifier, the cable loss.

The measurement results are obtained as described below:

$$AR_{pi} = \text{Cable loss} + \text{Antenna Factor} - \text{Preamplifier gain}$$

$$\text{Result} = P_{\text{Mea}} + AR_{pi}$$

Note:

1. The out-of-limit signal in the picture is the main frequency signal.
2. Only data in worst mode is provided.
3. Sweep the whole frequency band through the range from 30MHz to the 10th harmonic of the carrier, the Emissions in the frequency band 18GHz-26.5GHz is more than 20dB below the limit are not report.
4. The test data below 30MHz is more than 20dB lower than the limit value, so it is not provided in the report.
5. Horizontal and vertical polarity is all have been tested, the result of them is synthesized in the above data diagram.

Mainly Supply (S08)

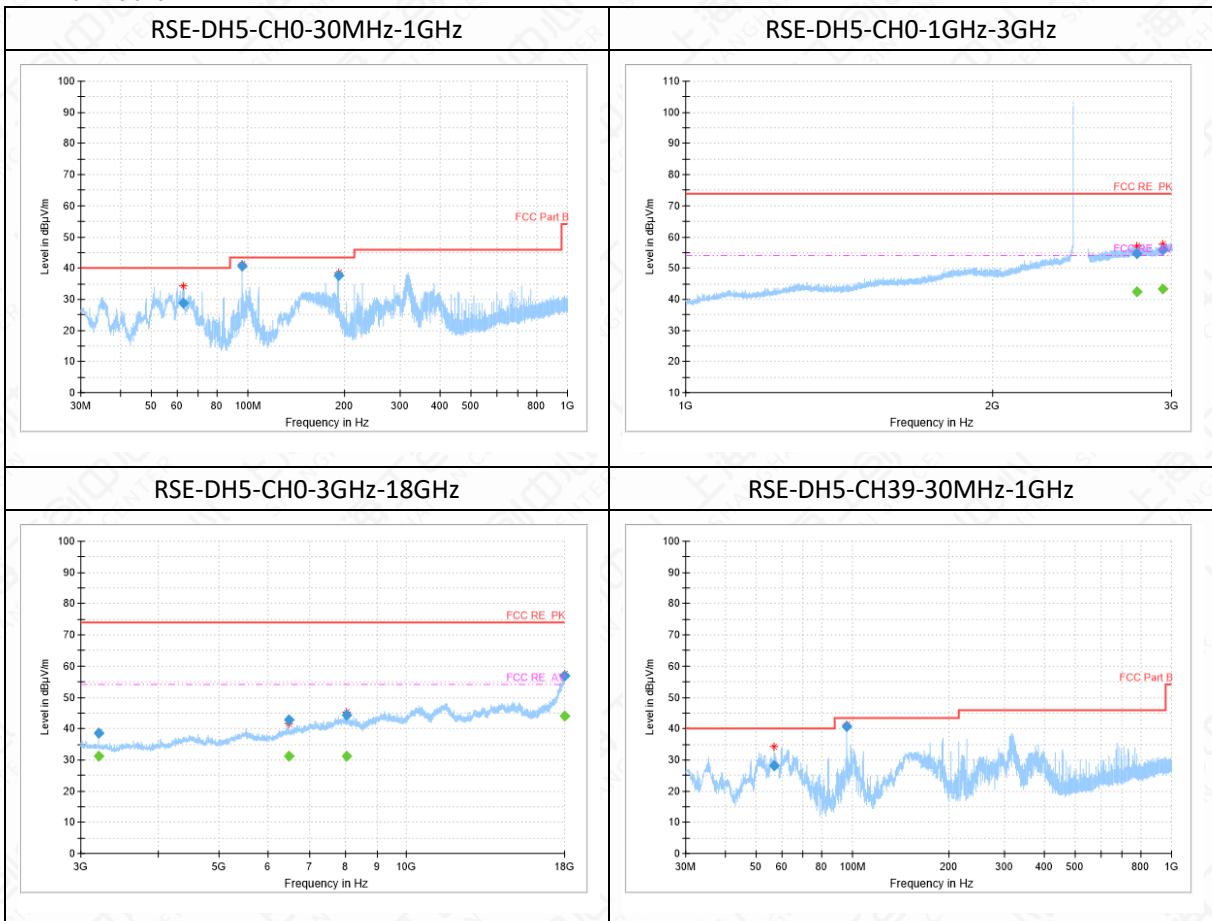

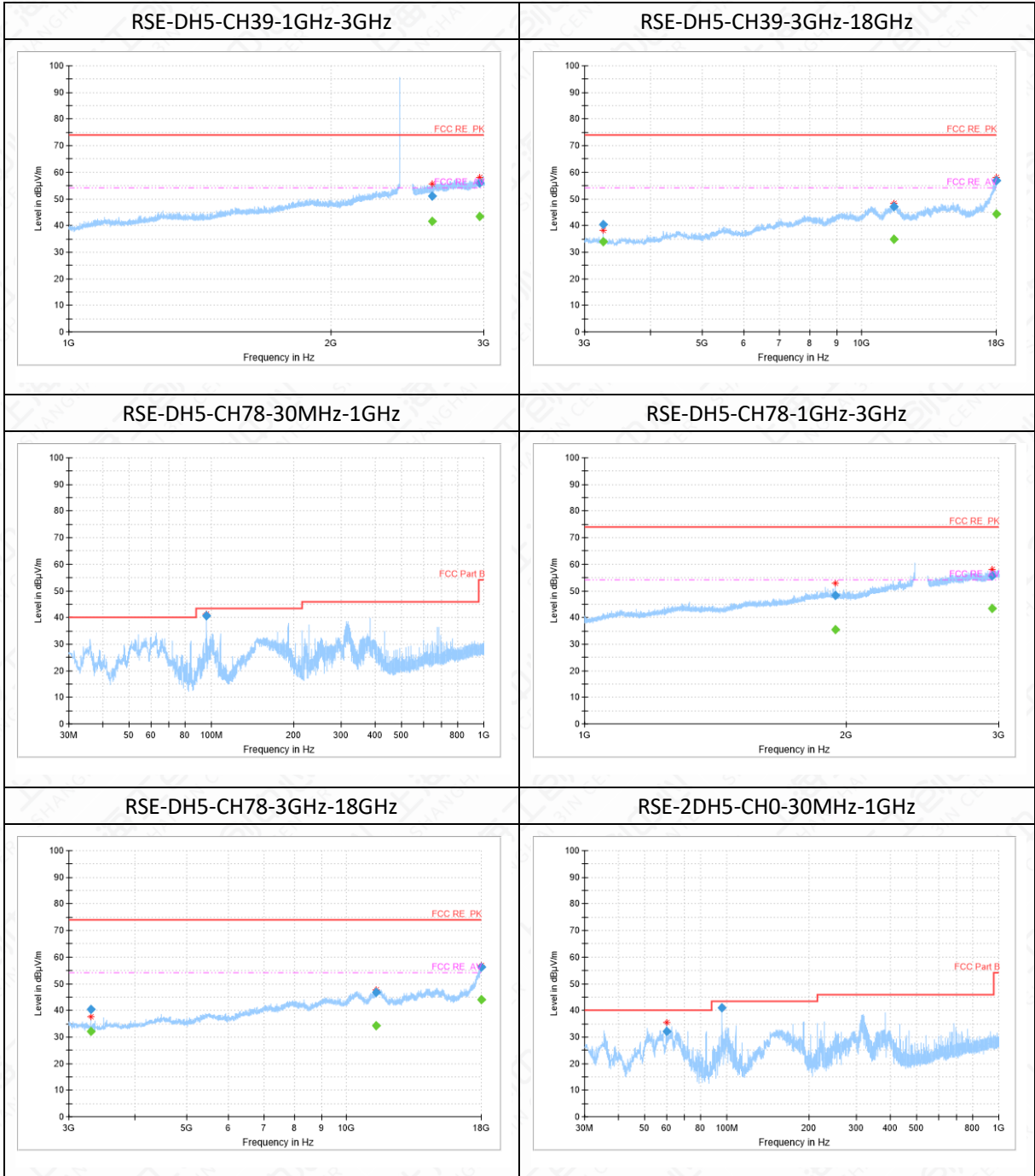



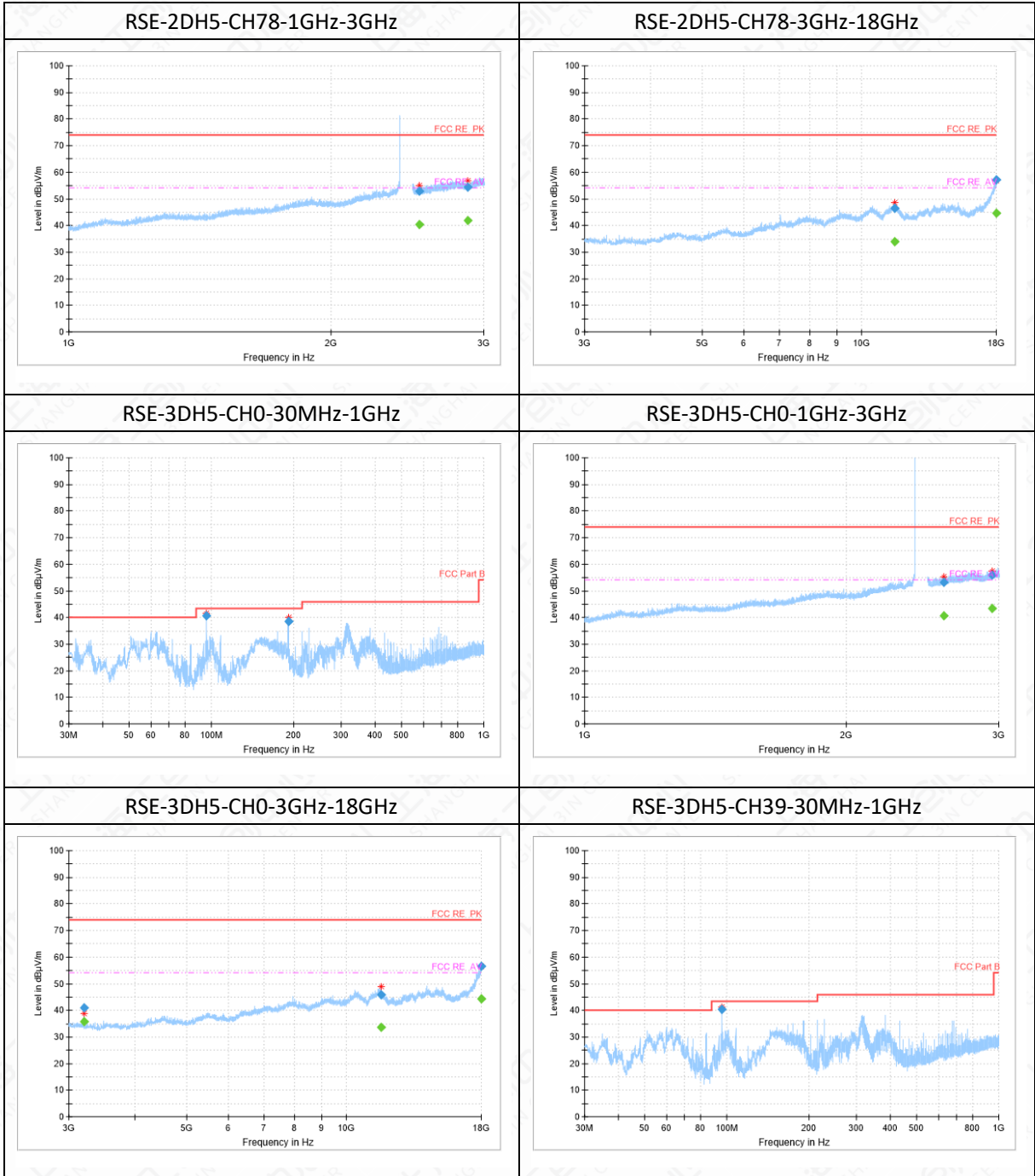

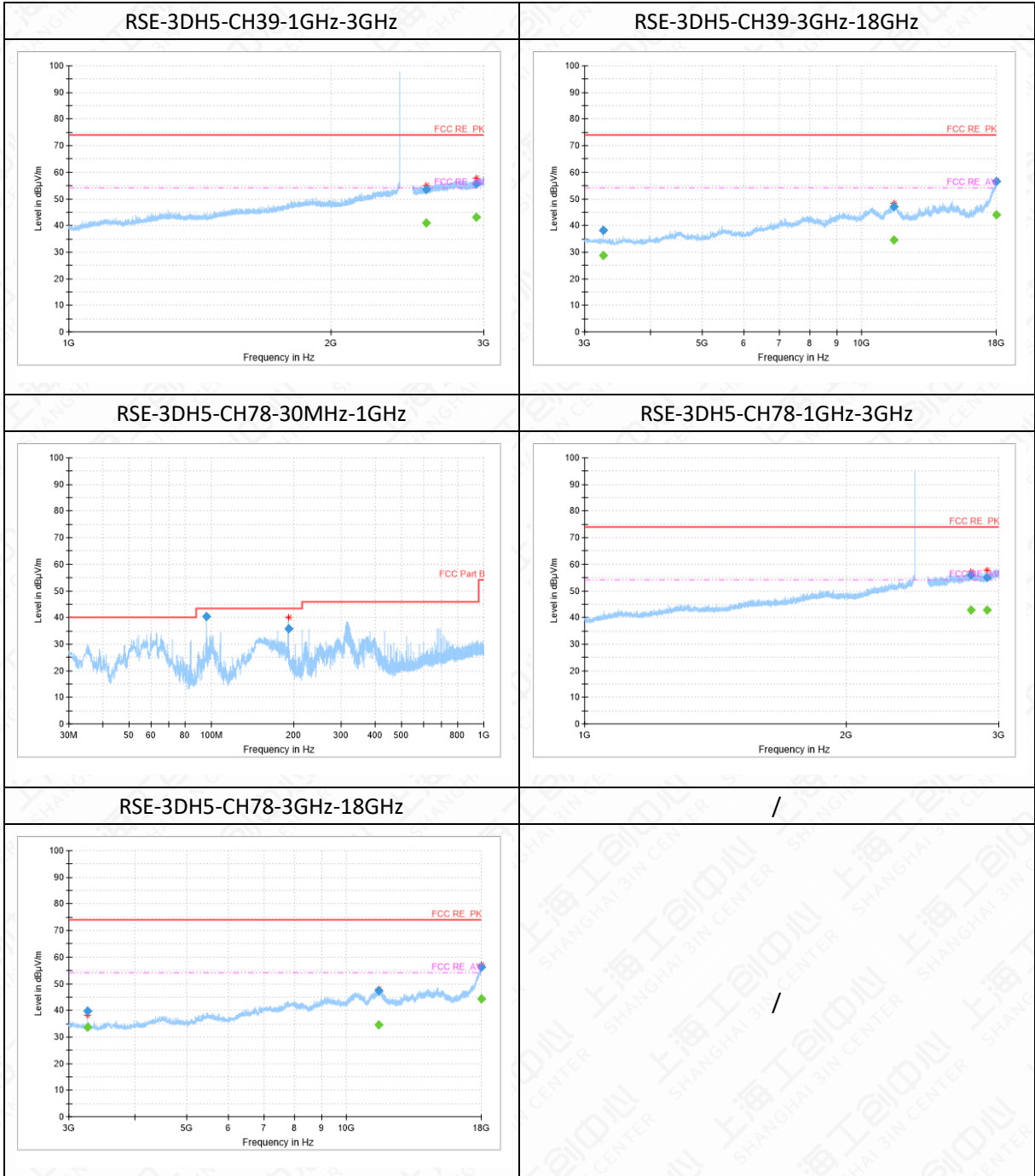

Bandedge

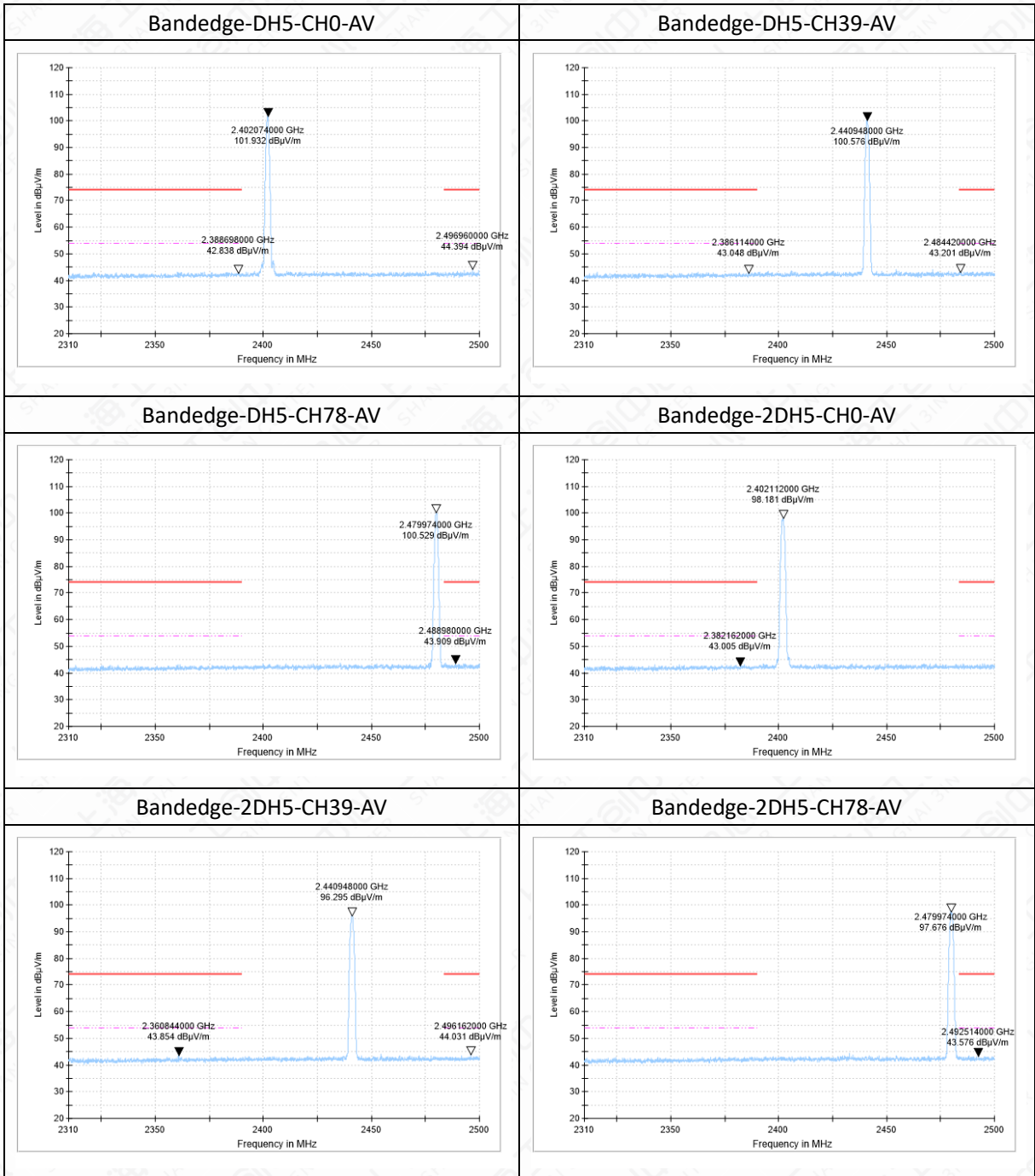

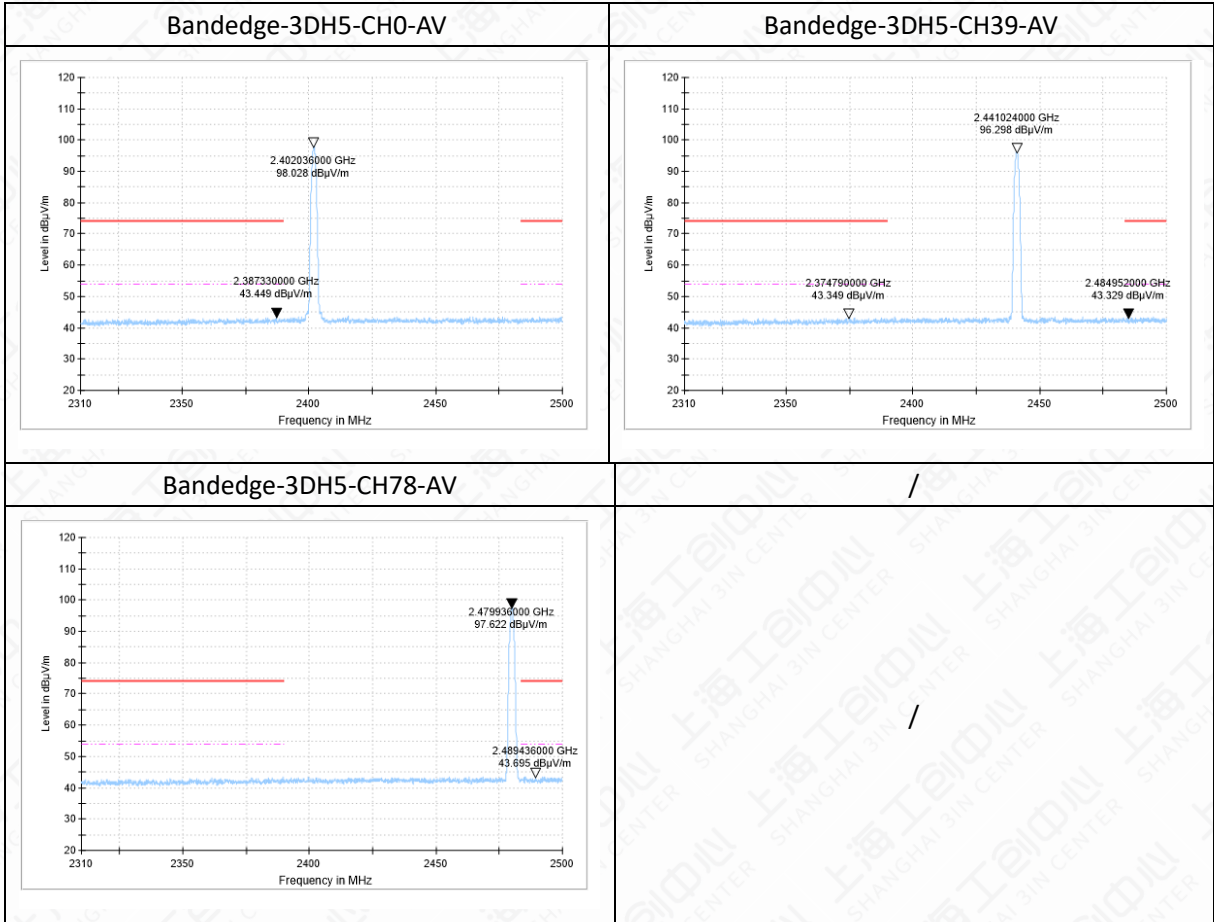

Secondary supply(S16)

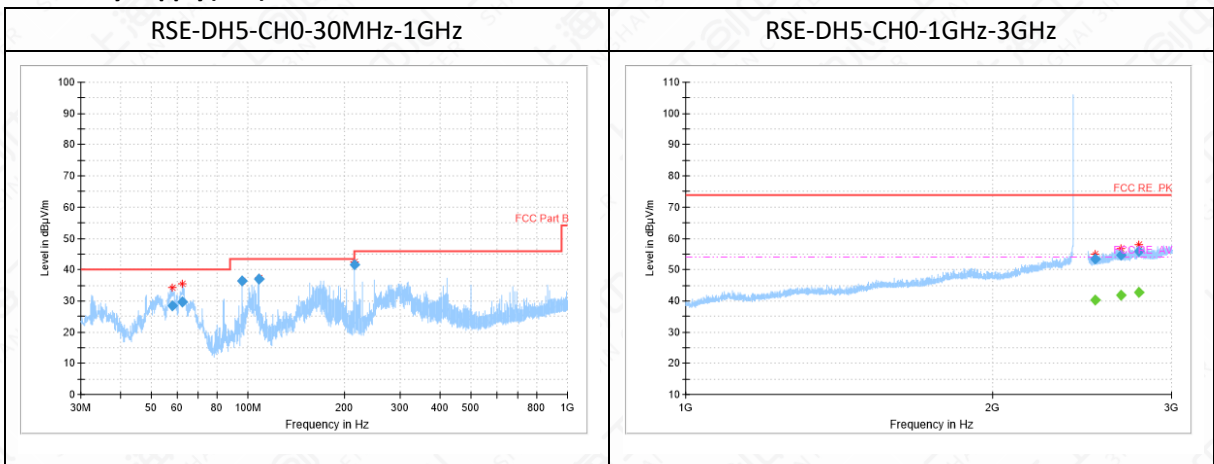

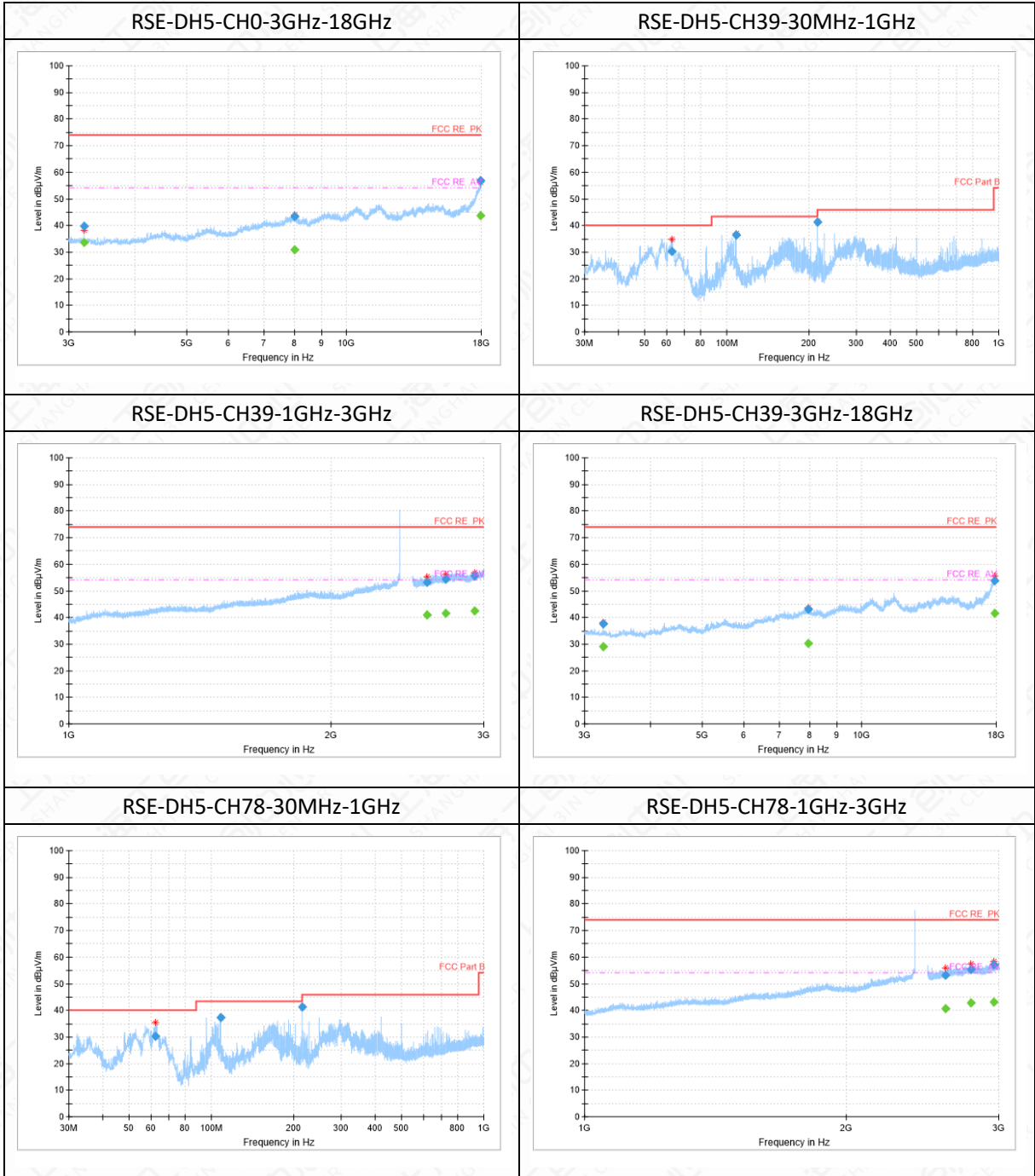

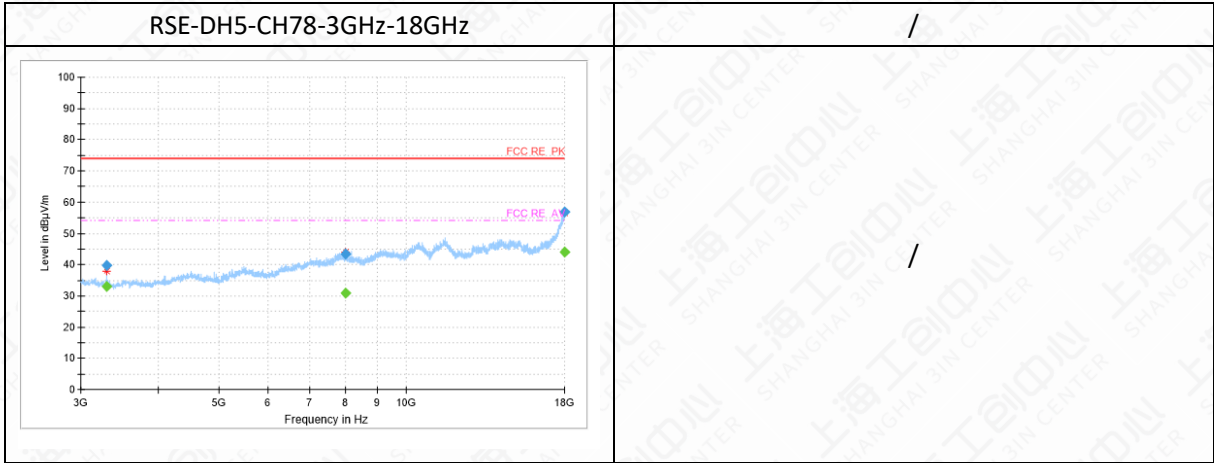

Bandedge

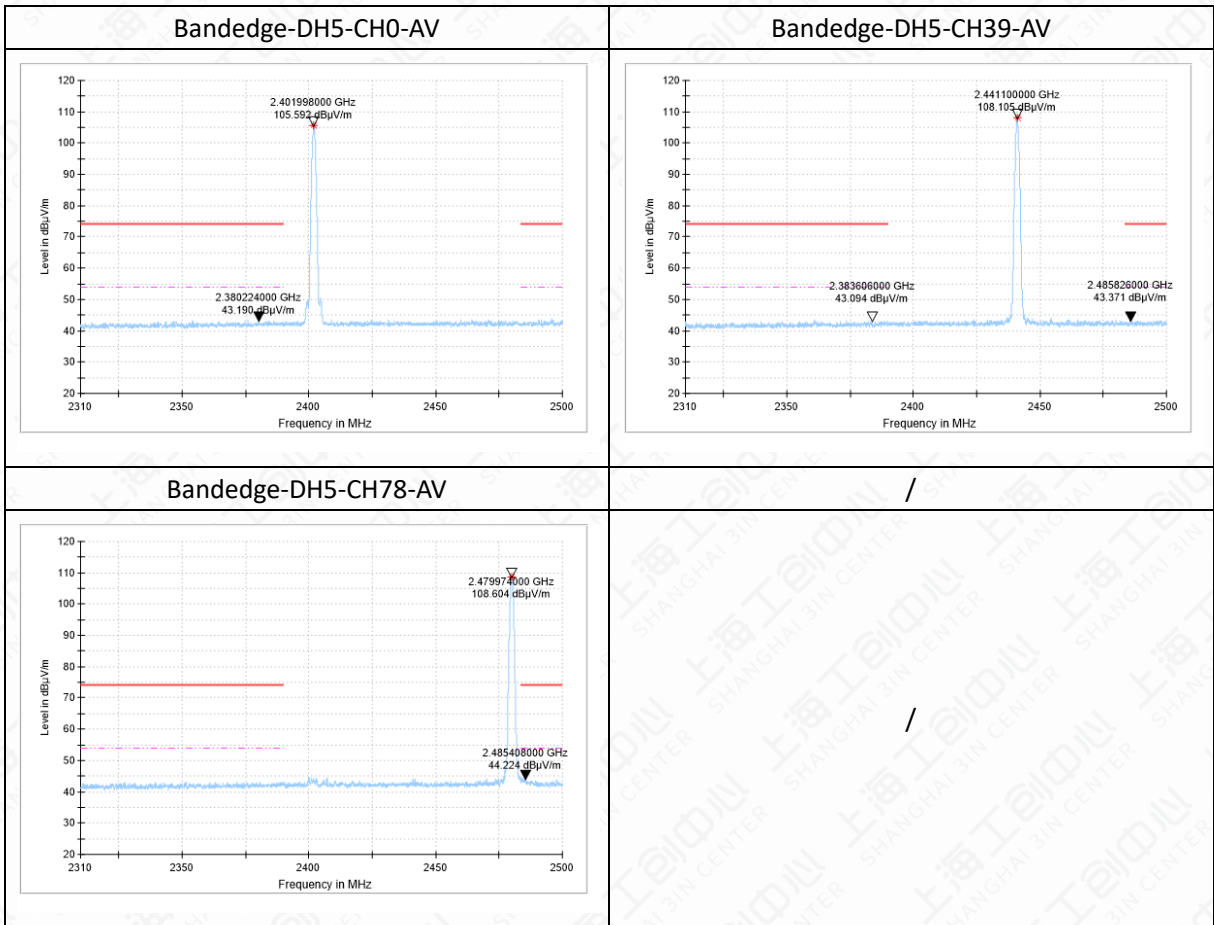

Thirdly supply(S12)

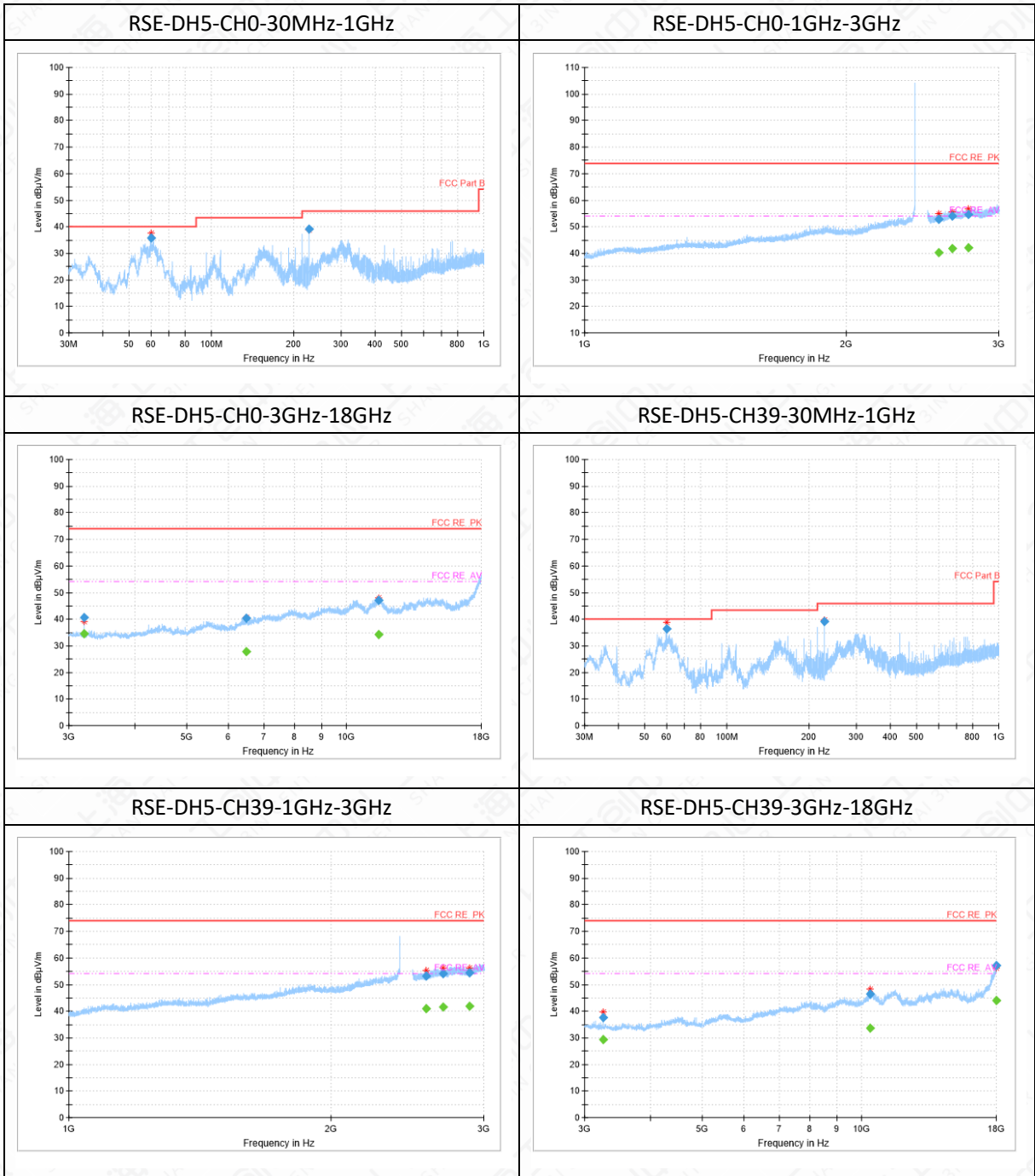

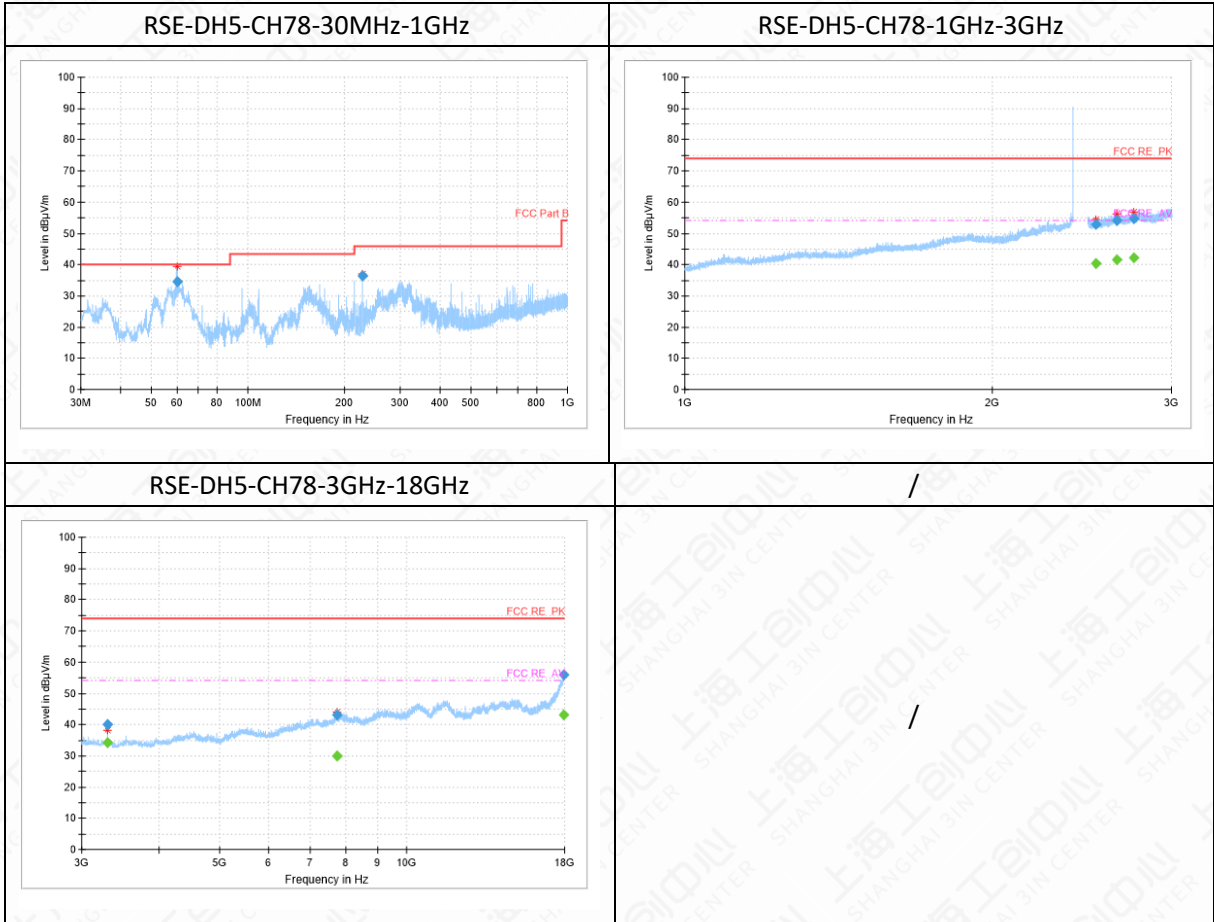

Bandedge

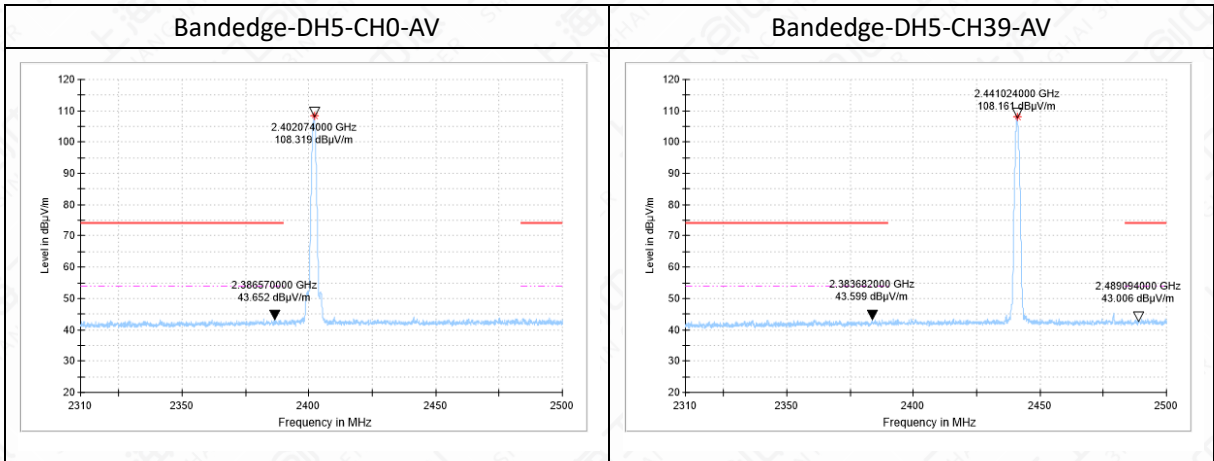

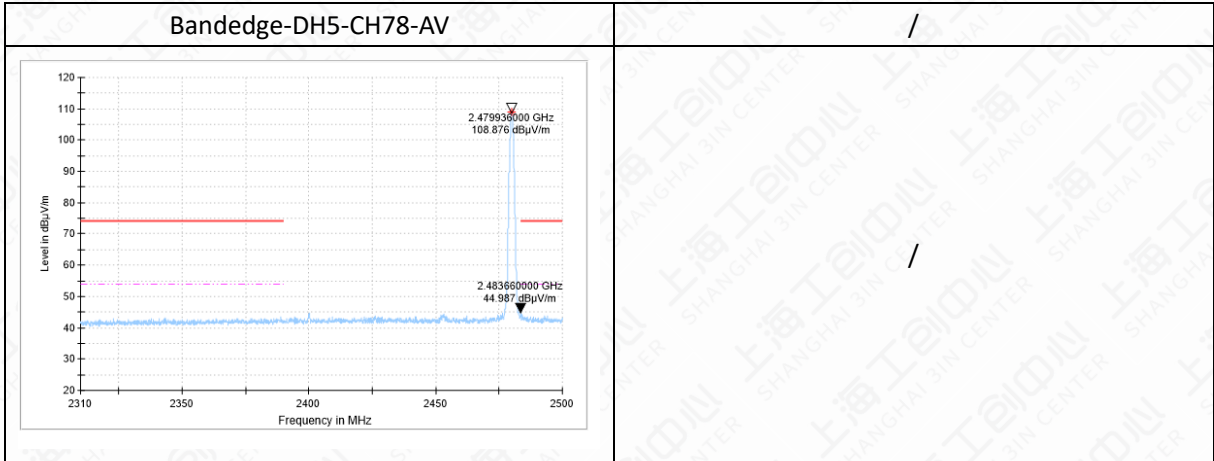

Note:

1. The out-of-limit signal in the picture is the main frequency signal.
2. Only data in worst mode is provided.
3. Sweep the whole frequency band through the range from 30MHz to the 10th harmonic of the carrier, the Emissions in the frequency band 18GHz-26.5GHz is more than 20dB below the limit are not report.
4. The test data below 30MHz is more than 20dB lower than the limit value, so it is not provided in the report.
5. Horizontal and vertical polarity is all have been tested, the result of them is synthesized in the above data diagram.

Mainly Supply (S08)

RSE-2DH5-CH0-30MHz-1GHz

Frequency (MHz)	QuasiPeak (dBµV/m)	ARpl (dB)	PMea (dBµV/m)	Margin(dB)	Limit(dBµV/m)	Polarity
60.0	32.24	-12	44.24	7.76	40.00	V
96.0	40.89	-14	54.89	2.61	43.50	V

RSE-2DH5-CH0-1GHz-3GHz

Frequency (MHz)	MaxPeak (dBµV/m)	ARpl (dB)	PMea (dBµV/m)	Margin(dB)	Limit(dBµV/m)	Polarity
2729.6	54.65	18	36.65	19.35	74.00	V
2940.8	55.45	19	36.45	18.55	74.00	V
2729.6	41.85	18	23.85	12.15	54.00	V
2940.8	43.17	19	24.17	10.83	54.00	V

RSE-2DH5-CH0-3GHz-18GHz

Frequency (MHz)	MaxPeak (dBµV/m)	ARpl (dB)	PMea (dBµV/m)	Margin(dB)	Limit(dBµV/m)	Polarity
3202.5	40.72	-11	51.72	33.28	74.00	H
10436.8	45.94	4	41.94	28.06	74.00	H
17974.6	56.54	19	37.54	17.46	74.00	V
3202.5	35.7	-11	46.7	18.30	54.00	H
10436.8	33.11	4	29.11	20.89	54.00	H

17974.6	44.03	19	25.03	9.97	54.00	V
---------	-------	----	-------	------	-------	---

RSE-2DH5-CH39-30MHz-1GHz

Frequency (MHz)	QuasiPeak (dBμV/m)	ARpl (dB)	PMea (dBμV/m)	Margin(dB)	Limit(dBμV/m)	Polarity
66.0	25.68	-14	39.68	14.32	40.00	V
96.0	40.52	-14	54.52	2.98	43.50	V

RSE-2DH5-CH39-1GHz-3GHz

Frequency (MHz)	MaxPeak (dBμV/m)	ARpl (dB)	PMea (dBμV/m)	Margin(dB)	Limit(dBμV/m)	Polarity
2660.9	54.56	17	37.56	19.44	74.00	V
2938.1	56.42	19	37.42	17.58	74.00	V
2660.9	41.61	17	24.61	12.39	54.00	V
2938.1	42.92	19	23.92	11.08	54.00	V

RSE-2DH5-CH39-3GHz-18GHz

Frequency (MHz)	MaxPeak (dBμV/m)	ARpl (dB)	PMea (dBμV/m)	Margin(dB)	Limit(dBμV/m)	Polarity
3254.1	37.94	-11	48.94	36.06	74.00	H
11511.6	47.49	5	42.49	26.51	74.00	V
17972.9	56.42	19	37.42	17.58	74.00	V
3254.1	28.45	-11	39.45	25.55	54.00	H
11511.6	34.62	5	29.62	19.38	54.00	V
17972.9	44.05	19	25.05	9.95	54.00	V

RSE-2DH5-CH78-30MHz-1GHz

Frequency (MHz)	QuasiPeak (dBμV/m)	ARpl (dB)	PMea (dBμV/m)	Margin(dB)	Limit(dBμV/m)	Polarity
96.0	40.83	-14	54.83	2.67	43.50	V
383.0	34.22	-8	42.22	11.78	46.00	V

RSE-2DH5-CH78-1GHz-3GHz

Frequency (MHz)	MaxPeak (dBμV/m)	ARpl (dB)	PMea (dBμV/m)	Margin(dB)	Limit(dBμV/m)	Polarity
2531.3	52.79	16	36.79	21.21	74.00	V
2877.7	54.42	18	36.42	19.58	74.00	H
2531.3	40.44	16	24.44	13.56	54.00	V
2877.7	41.93	18	23.93	12.07	54.00	H

RSE-2DH5-CH78-3GHz-18GHz

Frequency (MHz)	MaxPeak (dBμV/m)	ARpl (dB)	PMea (dBμV/m)	Margin(dB)	Limit(dBμV/m)	Polarity
11582.8	46.49	5	41.49	27.51	74.00	H
17999.0	57.27	20	37.27	16.73	74.00	H
11582.8	34.01	5	29.01	19.99	54.00	H

17999.0	44.53	20	24.53	9.47	54.00	H
---------	-------	----	-------	------	-------	---

RSE-3DH5-CH0-30MHz-1GHz

Frequency (MHz)	QuasiPeak (dBμV/m)	ARpl (dB)	PMea (dBμV/m)	Margin(dB)	Limit(dBμV/m)	Polarity
96.0	40.59	-14	54.59	2.91	43.50	V
191.5	38.4	-13	51.4	5.10	43.50	H

RSE-3DH5-CH0-1GHz-3GHz

Frequency (MHz)	MaxPeak (dBμV/m)	ARpl (dB)	PMea (dBμV/m)	Margin(dB)	Limit(dBμV/m)	Polarity
2594.1	53.23	16	37.23	20.77	74.00	V
2945.2	55.98	19	36.98	18.02	74.00	V
2594.1	40.72	16	24.72	13.28	54.00	V
2945.2	43.28	19	24.28	10.72	54.00	V

RSE-3DH5-CH0-3GHz-18GHz

Frequency (MHz)	MaxPeak (dBμV/m)	ARpl (dB)	PMea (dBμV/m)	Margin(dB)	Limit(dBμV/m)	Polarity
3202.5	40.94	-11	51.94	33.06	74.00	H
11629.6	45.94	5	40.94	28.06	74.00	V
17976.5	56.72	19	37.72	17.28	74.00	H
3202.5	35.73	-11	46.73	18.27	54.00	H
11629.6	33.52	5	28.52	20.48	54.00	V
17976.5	44.37	19	25.37	9.63	54.00	H

RSE-3DH5-CH39-30MHz-1GHz

Frequency (MHz)	QuasiPeak (dBμV/m)	ARpl (dB)	PMea (dBμV/m)	Margin(dB)	Limit(dBμV/m)	Polarity
96.0	40.51	-14	54.51	2.99	43.50	V

RSE-3DH5-CH39-1GHz-3GHz

Frequency (MHz)	MaxPeak (dBμV/m)	ARpl (dB)	PMea (dBμV/m)	Margin(dB)	Limit(dBμV/m)	Polarity
2574.6	53.39	16	37.39	20.61	74.00	H
2941.7	55.53	19	36.53	18.47	74.00	V
2574.6	41.08	16	25.08	12.92	54.00	H
2941.7	43.22	19	24.22	10.78	54.00	V

RSE-3DH5-CH39-3GHz-18GHz

Frequency (MHz)	MaxPeak (dBμV/m)	ARpl (dB)	PMea (dBμV/m)	Margin(dB)	Limit(dBμV/m)	Polarity
3254.1	38.17	-11	49.17	35.83	74.00	H
11515.8	47.17	5	42.17	26.83	74.00	V
17979.9	56.55	19	37.55	17.45	74.00	H
3254.1	28.78	-11	39.78	25.22	54.00	H

11515.8	34.53	5	29.53	19.47	54.00	V
17979.9	44.11	19	25.11	9.89	54.00	H

RSE-3DH5-CH78-30MHz-1GHz

Frequency (MHz)	QuasiPeak (dBμV/m)	ARpl (dB)	PMea (dBμV/m)	Margin(dB)	Limit(dBμV/m)	Polarity
96.0	40.24	-14	54.24	3.26	43.50	V
191.5	35.88	-13	48.88	7.62	43.50	H

RSE-3DH5-CH78-1GHz-3GHz

Frequency (MHz)	MaxPeak (dBμV/m)	ARpl (dB)	PMea (dBμV/m)	Margin(dB)	Limit(dBμV/m)	Polarity
2788.4	56.04	18	38.04	17.96	74.00	H
2909.6	55.04	18	37.04	18.96	74.00	H
2788.4	42.71	18	24.71	11.29	54.00	H
2909.6	42.69	18	24.69	11.31	54.00	H

RSE-3DH5-CH78-3GHz-18GHz

Frequency (MHz)	MaxPeak (dBμV/m)	ARpl (dB)	PMea (dBμV/m)	Margin(dB)	Limit(dBμV/m)	Polarity
3254.5	39.9	-11	50.9	34.10	74.00	H
11506.4	47.49	5	42.49	26.51	74.00	V
17997.1	56.41	20	36.41	17.59	74.00	V
3254.5	33.78	-11	44.78	20.22	54.00	H
11506.4	34.53	5	29.53	19.47	54.00	V
17997.1	44.27	20	24.27	9.73	54.00	V

RSE-DH5-CH0-30MHz-1GHz

Frequency (MHz)	QuasiPeak (dBμV/m)	ARpl (dB)	PMea (dBμV/m)	Margin(dB)	Limit(dBμV/m)	Polarity
63.0	28.66	-13	41.66	11.34	40.00	V
96.0	40.58	-14	54.58	2.92	43.50	V
191.5	37.58	-13	50.58	5.92	43.50	H

RSE-DH5-CH0-1GHz-3GHz

Frequency (MHz)	MaxPeak (dBμV/m)	ARpl (dB)	PMea (dBμV/m)	Margin(dB)	Limit(dBμV/m)	Polarity
2941.5	55.97	19	36.97	18.03	74.00	H
2776.1	54.67	18	36.67	19.33	74.00	H
2941.5	43.18	19	24.18	10.82	54.00	H
2776.1	42.44	18	24.44	11.56	54.00	H

RSE-DH5-CH0-3GHz-18GHz

Frequency (MHz)	MaxPeak (dBμV/m)	ARpl (dB)	PMea (dBμV/m)	Margin(dB)	Limit(dBμV/m)	Polarity
3202.5	38.59	-11	49.59	35.41	74.00	H

6473.9	42.95	-4	46.95	31.05	74.00	V
8015.1	44.25	0	44.25	29.75	74.00	H
17968.6	56.78	19	37.78	17.22	74.00	V
3202.5	31.15	-11	42.15	22.85	54.00	H
6473.9	31.34	-4	35.34	22.66	54.00	V
8015.1	31.15	0	31.15	22.85	54.00	H
17968.6	44.11	19	25.11	9.89	54.00	V

RSE-DH5-CH39-30MHz-1GHz

Frequency (MHz)	QuasiPeak (dB μ V/m)	ARpl (dB)	PMea (dB μ V/m)	Margin(dB)	Limit(dB μ V/m)	Polarity
56.9	28.19	-12	40.19	11.81	40.00	V
96.0	40.7	-14	54.7	2.80	43.50	V

RSE-DH5-CH39-1GHz-3GHz

Frequency (MHz)	MaxPeak (dB μ V/m)	ARpl (dB)	PMea (dB μ V/m)	Margin(dB)	Limit(dB μ V/m)	Polarity
2615.5	51.1	17	34.1	22.95	74.00	V
2963.7	56	19	37	18.00	74.00	H
2615.5	41.65	17	24.65	12.35	54.00	V
2963.7	43.29	19	24.29	10.71	54.00	H

RSE-DH5-CH39-3GHz-18GHz

Frequency (MHz)	MaxPeak (dB μ V/m)	ARpl (dB)	PMea (dB μ V/m)	Margin(dB)	Limit(dB μ V/m)	Polarity
3254.5	40.4	-11	51.4	33.60	74.00	H
11538.2	47.2	5	42.2	26.80	74.00	H
17970.9	56.92	19	37.92	17.08	74.00	H
3254.5	33.95	-11	44.95	20.05	54.00	H
11538.2	34.71	5	29.71	19.29	54.00	H
17970.9	44.31	19	25.31	9.69	54.00	H

RSE-DH5-CH78-30MHz-1GHz

Frequency (MHz)	QuasiPeak (dB μ V/m)	ARpl (dB)	PMea (dB μ V/m)	Margin(dB)	Limit(dB μ V/m)	Polarity
96.0	40.57	-14	54.57	2.93	43.50	V

RSE-DH5-CH78-1GHz-3GHz

Frequency (MHz)	MaxPeak (dB μ V/m)	ARpl (dB)	PMea (dB μ V/m)	Margin(dB)	Limit(dB μ V/m)	Polarity
1944.4	48.19	11	37.19	25.81	74.00	H
2949.7	55.66	19	36.66	18.34	74.00	H
1944.4	35.49	11	24.49	18.51	54.00	H
2949.7	43.33	19	24.33	10.67	54.00	H

RSE-DH5-CH78-3GHz-18GHz

Frequency (MHz)	MaxPeak (dB μ V/m)	ARpl (dB)	PMea (dB μ V/m)	Margin(dB)	Limit(dB μ V/m)	Polarity
3306.6	40.26	-11	51.26	33.74	74.00	H
11393.4	46.65	5	41.65	27.35	74.00	H
17974.8	56.42	19	37.42	17.58	74.00	V
3306.6	32.08	-11	43.08	21.92	54.00	H
11393.4	34.18	5	29.18	19.82	54.00	H
17974.8	43.99	19	24.99	10.01	54.00	V

Secondary supply(S16)
RSE-DH5-CH0-30MHz-1GHz

Frequency (MHz)	QuasiPeak (dB μ V/m)	ARpl (dB)	PMea (dB μ V/m)	Margin(dB)	Limit(dB μ V/m)	Polarity
57.9	28.49	-12	40.49	11.51	40.00	V
62.4	29.73	-13	42.73	10.27	40.00	V
96.0	36.34	-14	50.34	7.16	43.50	V
108.0	37.01	-13	50.01	6.49	43.50	V
216.0	41.71	-12	53.71	1.79	43.50	H

RSE-DH5-CH0-1GHz-3GHz

Frequency (MHz)	MaxPeak (dB μ V/m)	ARpl (dB)	PMea (dB μ V/m)	Margin(dB)	Limit(dB μ V/m)	Polarity
2525.1	53.32	15	38.32	20.68	74.00	V
2677.6	54.5	17	37.5	19.50	74.00	V
2784.9	55.77	18	37.77	18.23	74.00	V
2525.1	40.29	15	25.29	13.71	54.00	V
2677.6	41.87	17	24.87	12.13	54.00	V
2784.9	42.65	18	24.65	11.35	54.00	V

RSE-DH5-CH0-3GHz-18GHz

Frequency (MHz)	MaxPeak (dB μ V/m)	ARpl (dB)	PMea (dB μ V/m)	Margin(dB)	Limit(dB μ V/m)	Polarity
3202.5	39.65	-11	50.65	34.35	74.00	H
7997.4	43.57	0	43.57	30.43	74.00	V
17958.8	56.97	19	37.97	17.03	74.00	H
3202.5	33.78	-11	44.78	20.22	54.00	H
7997.4	30.89	0	30.89	23.11	54.00	V
17958.8	43.69	19	24.69	10.31	54.00	H

RSE-DH5-CH39-30MHz-1GHz

Frequency (MHz)	QuasiPeak (dB μ V/m)	ARpl (dB)	PMea (dB μ V/m)	Margin(dB)	Limit(dB μ V/m)	Polarity
63.0	30.18	-13	43.18	9.82	40.00	V
108.0	36.47	-13	49.47	7.03	43.50	V

216.0	41.41	-12	53.41	2.09	43.50	H
-------	-------	-----	-------	------	-------	---

RSE-DH5-CH39-1GHz-3GHz

Frequency (MHz)	MaxPeak (dBμV/m)	ARpl (dB)	PMea (dBμV/m)	Margin(dB)	Limit(dBμV/m)	Polarity
2581.2	53.29	16	37.29	20.71	74.00	V
2710.1	54.44	17	37.44	19.56	74.00	H
2925.8	55.54	18	37.54	18.46	74.00	V
2581.2	40.95	16	24.95	13.05	54.00	V
2710.1	41.66	17	24.66	12.34	54.00	H
2925.8	42.5	18	24.5	11.50	54.00	V

RSE-DH5-CH39-3GHz-18GHz

Frequency (MHz)	MaxPeak (dBμV/m)	ARpl (dB)	PMea (dBμV/m)	Margin(dB)	Limit(dBμV/m)	Polarity
3254.1	37.57	-11	48.57	36.43	74.00	H
7951.0	43.21	0	43.21	30.79	74.00	H
17855.6	53.93	17	36.93	20.07	74.00	H
3254.1	29.09	-11	40.09	24.91	54.00	H
7951.0	30.39	0	30.39	23.61	54.00	H
17855.6	41.52	17	24.52	12.48	54.00	H

RSE-DH5-CH78-30MHz-1GHz

Frequency (MHz)	QuasiPeak (dBμV/m)	ARpl (dB)	PMea (dBμV/m)	Margin(dB)	Limit(dBμV/m)	Polarity
62.5	30.37	-13	43.37	9.63	40.00	V
108.0	37.43	-13	50.43	6.07	43.50	V
216.0	41.31	-12	53.31	2.19	43.50	H

RSE-DH5-CH78-1GHz-3GHz

Frequency (MHz)	MaxPeak (dBμV/m)	ARpl (dB)	PMea (dBμV/m)	Margin(dB)	Limit(dBμV/m)	Polarity
2603.1	53.27	16	37.27	20.73	74.00	H
2788.4	55.39	18	37.39	18.61	74.00	H
2959.8	57.24	19	38.24	16.76	74.00	H
2603.1	40.71	16	24.71	13.29	54.00	H
2788.4	42.68	18	24.68	11.32	54.00	H
2959.8	43.2	19	24.2	10.80	54.00	H

RSE-DH5-CH78-3GHz-18GHz

Frequency (MHz)	MaxPeak (dBμV/m)	ARpl (dB)	PMea (dBμV/m)	Margin(dB)	Limit(dBμV/m)	Polarity
3306.6	39.62	-11	50.62	34.38	74.00	H
7988.9	43.43	0	43.43	30.57	74.00	H
17979.9	57.03	19	38.03	16.97	74.00	H

3306.6	33.05	-11	44.05	20.95	54.00	H
7988.9	30.74	0	30.74	23.26	54.00	H
17979.9	44.15	19	25.15	9.85	54.00	H

Thirdly supply(S12)
RSE-DH5-CH0-30MHz-1GHz

Frequency (MHz)	QuasiPeak (dB μ V/m)	ARpl (dB)	PMea (dB μ V/m)	Margin(dB)	Limit(dB μ V/m)	Polarity
60.0	35.92	-12	47.92	4.08	40.00	V
228.0	39.21	-12	51.21	6.79	46.00	H

RSE-DH5-CH0-1GHz-3GHz

Frequency (MHz)	MaxPeak (dB μ V/m)	ARpl (dB)	PMea (dB μ V/m)	Margin(dB)	Limit(dB μ V/m)	Polarity
2557.4	52.78	16	36.78	21.22	74.00	V
2649.9	53.96	17	36.96	20.04	74.00	V
2768.3	54.8	18	36.8	19.20	74.00	H

RSE-DH5-CH0-1GHz-3GHz

Frequency (MHz)	Average (dB μ V/m)	ARpl (dB)	PMea (dB μ V/m)	Margin(dB)	Limit(dB μ V/m)	Polarity
2557.4	40.42	16	24.42	13.58	54.00	V
2649.9	41.72	17	24.72	12.28	54.00	V
2768.3	42.13	18	24.13	11.87	54.00	H

RSE-DH5-CH0-3GHz-18GHz

Frequency (MHz)	MaxPeak (dB μ V/m)	ARpl (dB)	PMea (dB μ V/m)	Margin(dB)	Limit(dB μ V/m)	Polarity
3202.5	40.53	-11	51.53	33.47	74.00	H
6472.0	40.29	-4	44.29	33.71	74.00	V
11528.9	47.1	5	42.1	26.90	74.00	V

RSE-DH5-CH0-3GHz-18GHz

Frequency (MHz)	Average (dB μ V/m)	ARpl (dB)	PMea (dB μ V/m)	Margin(dB)	Limit(dB μ V/m)	Polarity
3202.5	34.67	-11	45.67	19.33	54.00	H
6472.0	27.73	-4	31.73	26.27	54.00	V
11528.9	34.34	5	29.34	19.66	54.00	V

RSE-DH5-CH39-30MHz-1GHz

Frequency (MHz)	QuasiPeak (dB μ V/m)	ARpl (dB)	PMea (dB μ V/m)	Margin(dB)	Limit(dB μ V/m)	Polarity
60.0	36.28	-12	48.28	3.72	40.00	V
228.0	39.25	-12	51.25	6.75	46.00	H

RSE-DH5-CH39-1GHz-3GHz

Frequency	MaxPeak	ARpl (dB)	PMea	Margin(dB)	Limit(dB μ V/m)	Polarity
-----------	---------	-----------	------	------------	---------------------	----------

(MHz)	(dB μ V/m)		(dB μ V/m)			
2577.9	53.33	16	37.33	20.67	74.00	H
2693.1	54.01	17	37.01	19.99	74.00	H
2890.7	54.43	18	36.43	19.57	74.00	V

RSE-DH5-CH39-1GHz-3GHz

Frequency (MHz)	Average (dB μ V/m)	ARpl (dB)	PMea (dB μ V/m)	Margin(dB)	Limit(dB μ V/m)	Polarity
2577.9	41.01	16	25.01	12.99	54.00	H
2693.1	41.61	17	24.61	12.39	54.00	H
2890.7	41.95	18	23.95	12.05	54.00	V

RSE-DH5-CH39-3GHz-18GHz

Frequency (MHz)	MaxPeak (dB μ V/m)	ARpl (dB)	PMea (dB μ V/m)	Margin(dB)	Limit(dB μ V/m)	Polarity
3254.1	37.65	-11	48.65	36.35	74.00	H
10389.4	46.44	3	43.44	27.56	74.00	V
17976.5	57.15	19	38.15	16.85	74.00	V
3254.1	29.39	-11	40.39	24.61	54.00	H
10389.4	33.52	3	30.52	20.48	54.00	V
17976.5	44.08	19	25.08	9.92	54.00	V

RSE-DH5-CH78-30MHz-1GHz

Frequency (MHz)	QuasiPeak (dB μ V/m)	ARpl (dB)	PMea (dB μ V/m)	Margin(dB)	Limit(dB μ V/m)	Polarity
60.0	34.64	-12	46.64	5.36	40.00	V
228.0	36.28	-12	48.28	9.72	46.00	H

RSE-DH5-CH78-1GHz-3GHz

Frequency (MHz)	MaxPeak (dB μ V/m)	ARpl (dB)	PMea (dB μ V/m)	Margin(dB)	Limit(dB μ V/m)	Polarity
2528.2	52.97	16	36.97	21.03	74.00	H
2651.5	54.28	17	37.28	19.72	74.00	V
2754.6	54.7	18	36.7	19.30	74.00	V
2528.2	40.3	16	24.3	13.70	54.00	H
2651.5	41.69	17	24.69	12.31	54.00	V
2754.6	42.29	18	24.29	11.71	54.00	V

RSE-DH5-CH78-3GHz-18GHz

Frequency (MHz)	MaxPeak (dB μ V/m)	ARpl (dB)	PMea (dB μ V/m)	Margin(dB)	Limit(dB μ V/m)	Polarity
3306.6	40.05	-11	51.05	33.95	74.00	H
7745.6	43.1	-1	44.1	30.90	74.00	H
17929.2	55.93	18	37.93	18.07	74.00	H
3306.6	34.27	-11	45.27	19.73	54.00	H

7745.6	30.07	-1	31.07	23.93	54.00	H
17929.2	43.24	18	25.24	10.76	54.00	H

Note: Only the worst case is written in the report.

6.5 Time Of Occupancy (Dwell Time)

6.5.1 Measurement Limit

Standard	Limit(ms)
FCC 47 Part 15.247 (a) (1) (iii)	<400
RSS-247 5.1	<400

6.5.2 Test procedures

The measurement is according to ANSI C63.10 clause 7.8.4

1. Connect the EUT through cable and divide with spectrum analyzer.
2. Enable the EUT transmit maximum power.
3. Set the spectrum analyzer as step 4 to step 8.
4. Span: Zero span, centered on a hopping channel.
5. RBW shall be \leq channel spacing and where possible RBW should be set $\gg 1/T$, where T is the expected dwell time per channel.
6. Sweep: As necessary to capture the entire dwell time per hopping channel; where possible use a video trigger and trigger delay so that the transmitted signal starts a little to the right of the start of the plot. The trigger level might need slight adjustment to prevent triggering when the system hops on an adjacent channel; a second plot might be needed with a longer sweep time to show two successive hops on a channel.
7. Detector function: Peak.
8. Trace: Clear-write, single sweep
9. Place markers at the start of the first transmission on the channel and at the end of the last transmission. The dwell time per hop is the time between these two markers.

To determine the number of hops on a channel in the regulatory observation period repeat the measurement using a longer sweep time. When the device uses a single hopping sequence the period of measurement should be sufficient to capture at least 2 hops. When the device uses a dynamic hopping sequence, or the sequence varies, the period of measurement may need to capture multiple hops to better determine the average time of occupancy. Count the number of hops on the channel across the sweep time. The average number of hops on the same channel within the regulatory observation period is calculated from the number of hops on the channel divided by the spectrum analyzer sweep time multiplied by the regulatory observation period. For example, if three hops are counted with an analyzer sweep time of 500 ms and the regulatory observation period is 10 s, then the number of hops in that ten seconds is $3 / 0.5 \times 10$, or 60 hops.

The average time of occupancy is calculated by multiplying the dwell time per hop by the number of hops in the observation period. Where the device shares the same hopping algorithms (dwell time, channel selection) across multiple data rates or modulation schemes then the time of occupancy need only be measured for one of those modulation schemes or data rates. If the dwell time value varies with different modes of operation (data rate, modulation format, number of hopping channels, etc.), then repeat this test for each variation in dwell time.

Spectral plots of the channel occupancy shall be included in the report.

6.5.3 Test Setup

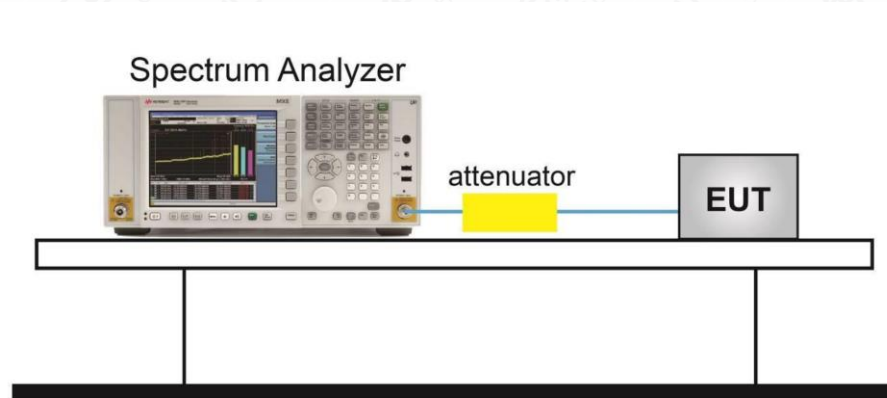

Measurement Results

TestMode	Antenna	Frequency[MHz]	BurstWidth [ms]	TotalHops [Num]	Result[s]	Limit[s]	Verdict
DH5	Ant1	Hop	2.891	80	0.231	≤0.4	PASS
2DH5	Ant1	Hop	2.891	110	0.318	≤0.4	PASS
3DH5	Ant1	Hop	2.891	100	0.289	≤0.4	PASS

Test Graphs

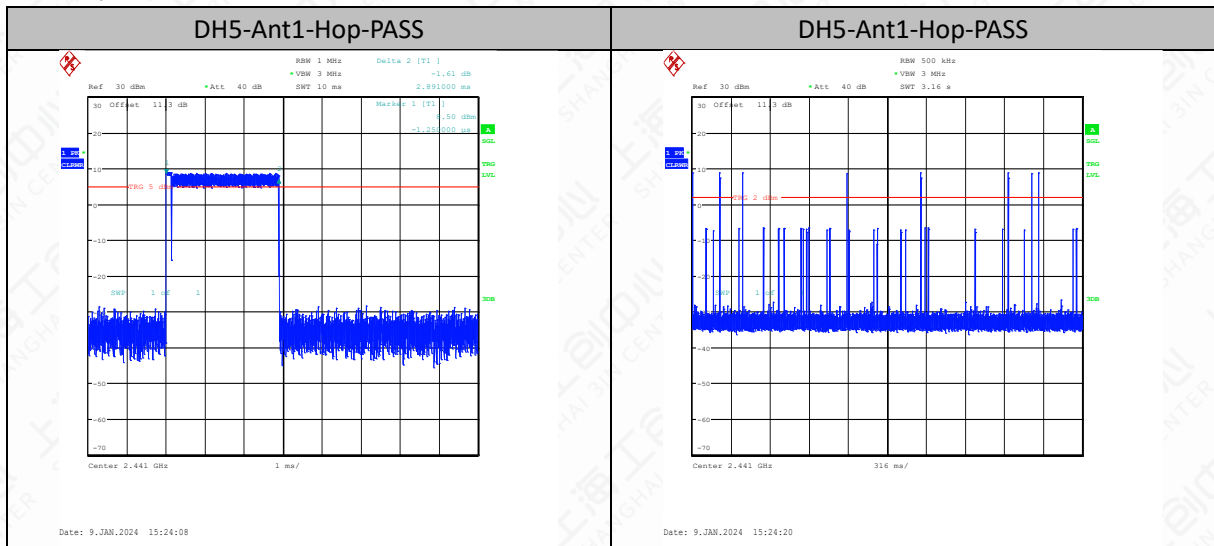

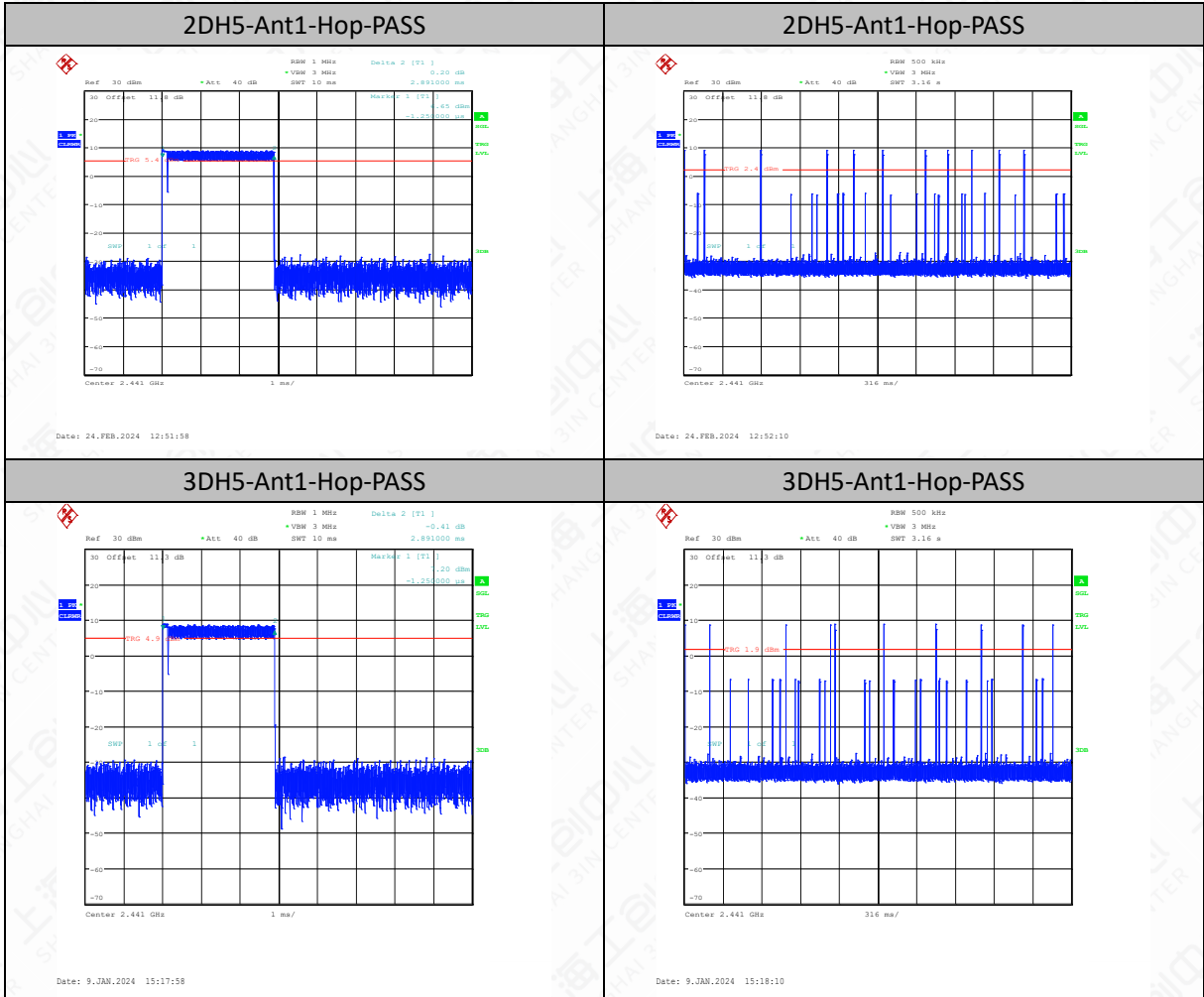

6.6 20dB Bandwidth

6.6.1 Measurement Limit

Standard	Limit
FCC 47 Part 15.247(a)	N/A
RSS-247 5.1	N/A

6.6.2 Test procedures

The measurement is according to ANSI C63.10 clause 7.8.7

1. Connect the EUT through cable and divide with CMW270 and spectrum analyzer.
2. Enable the EUT transmit maximum power.
3. Set the spectrum analyzer as step 4 to step 7.
4. Span: two or five times of OBW
5. RBW= 1% to 5% of the OBW; VBW is approximately three times of RBW; Max Hold.
6. Select the max peak, and N DB DOWN=20dB.
7. Record the results.

6.6.3 Test Setup

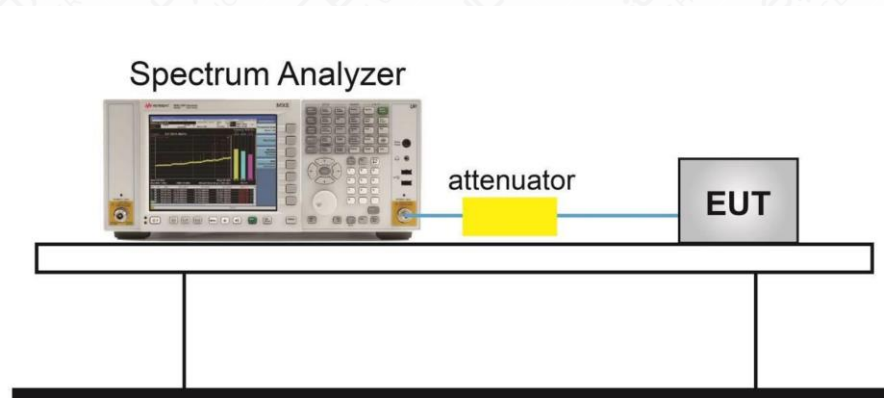

6.6.4 Measurement Result

TestMode	Antenna	Frequency[MHz]	20db EBW[MHz]	FL[MHz]	FH[MHz]	Limit[MHz]	Verdict
DH5	Ant1	2402	1.04	2401.48	2402.52	---	---
DH5	Ant1	2441	1.04	2440.48	2441.52	---	---
DH5	Ant1	2480	1.04	2479.48	2480.52	---	---
2DH5	Ant1	2402	1.36	2401.31	2402.67	---	---
2DH5	Ant1	2441	1.36	2440.32	2441.67	---	---
2DH5	Ant1	2480	1.36	2479.31	2480.67	---	---
3DH5	Ant1	2402	1.30	2401.34	2402.63	---	---
3DH5	Ant1	2441	1.29	2440.34	2441.63	---	---
3DH5	Ant1	2480	1.29	2479.34	2480.63	---	---

Test Graphs

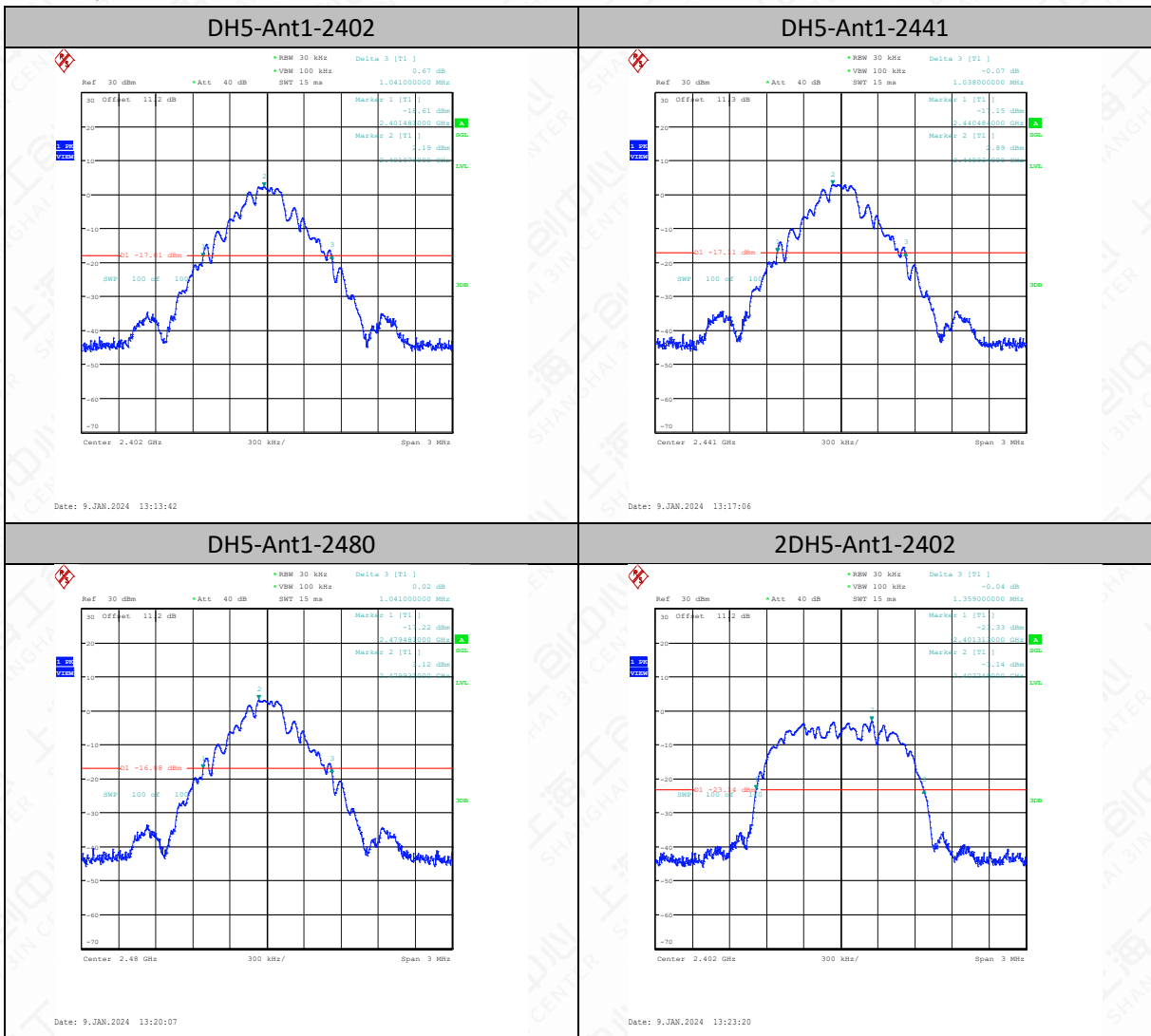

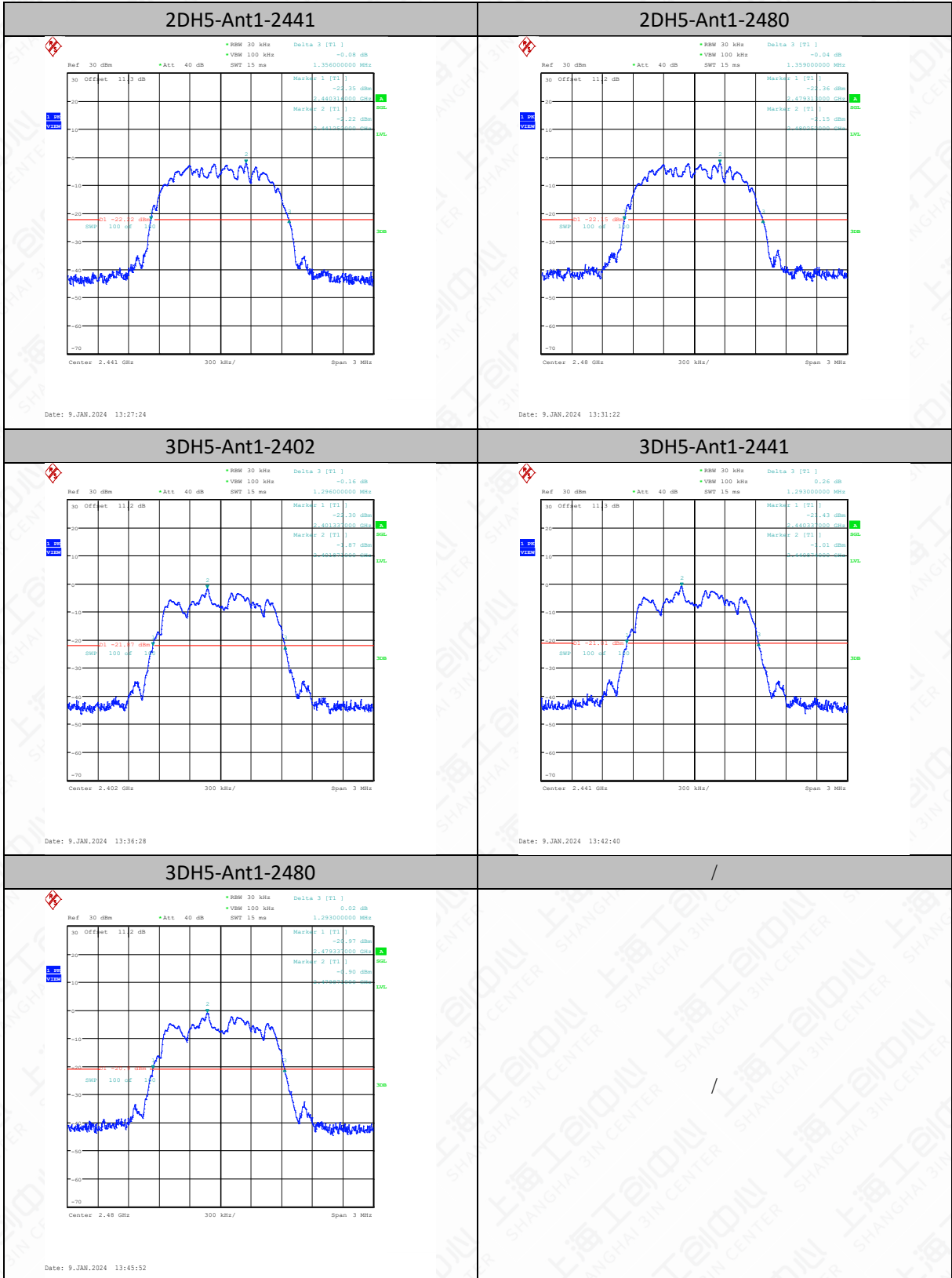

6.7 99% Occupied Bandwidth

6.7.1 Measurement Limit

Standard	Limit
15.247(a)	N/A
RSS-GEN 6.7	N/A

6.7.2 Test procedures

The measurement is according to ANSI C63.10 clause 6.9.3.

1. The output power of EUT was connected to the spectrum analyzer. The path loss was compensated to the results for each measurement.
2. Enable EUT transmitter maximum power continuously.
3. Set RBW shall be in the range of 1% to 5% of the OBW.
4. Set the VBW $\geq [3 \times \text{RBW}]$.
5. Detector = peak.
6. Trace mode = max hold.
7. Sweep = auto couple.
8. Allow the trace to stabilize.
9. The occupied bandwidth is the frequency bandwidth such that, below its lower and above its upper frequency limits, the mean powers are each equal to 0.5% of the total mean power of the given emission.

6.7.3 Test setup

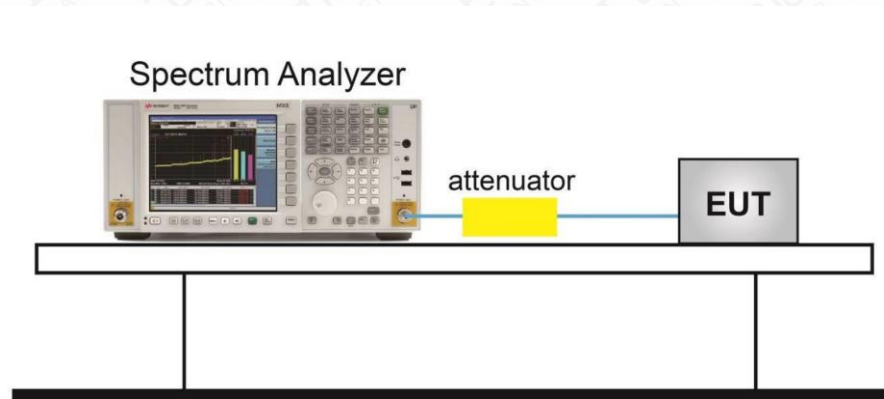

6.7.4 Measurement Result

TestMode	Antenna	Frequency[MHz]	OCB [MHz]	FL[MHz]	FH[MHz]	Limit[MHz]	Verdict
DH5	Ant1	2402	0.903	2401.5350	2402.4380	---	---
DH5	Ant1	2441	0.903	2440.5350	2441.4380	---	---
DH5	Ant1	2480	0.903	2479.5320	2480.4350	---	---
2DH5	Ant1	2402	1.194	2401.3970	2402.5910	---	---
2DH5	Ant1	2441	1.191	2440.3970	2441.5880	---	---
2DH5	Ant1	2480	1.194	2479.3940	2480.5880	---	---
3DH5	Ant1	2402	1.167	2401.4120	2402.5790	---	---
3DH5	Ant1	2441	1.164	2440.4120	2441.5760	---	---
3DH5	Ant1	2480	1.164	2479.4120	2480.5760	---	---

Test graphs

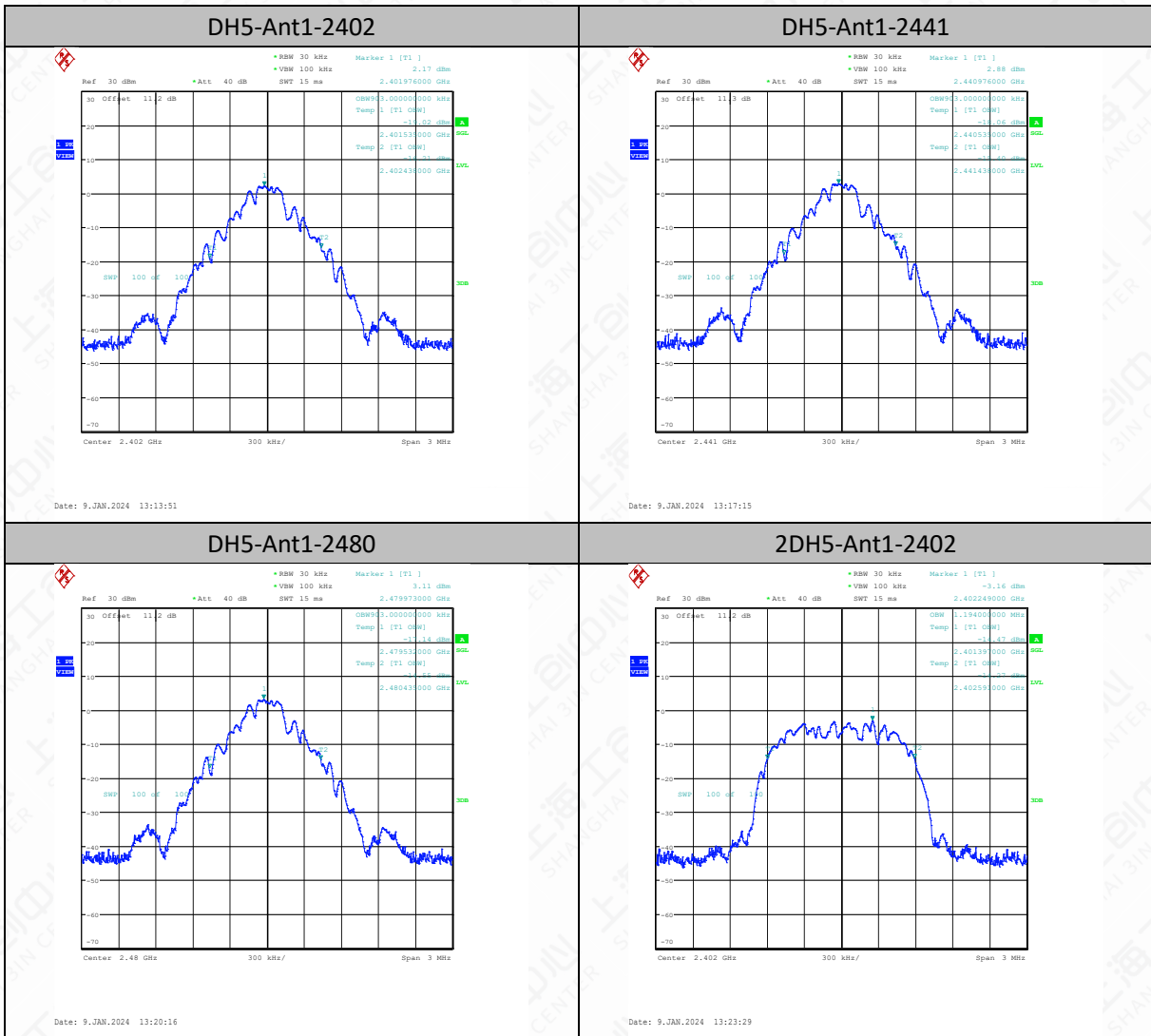

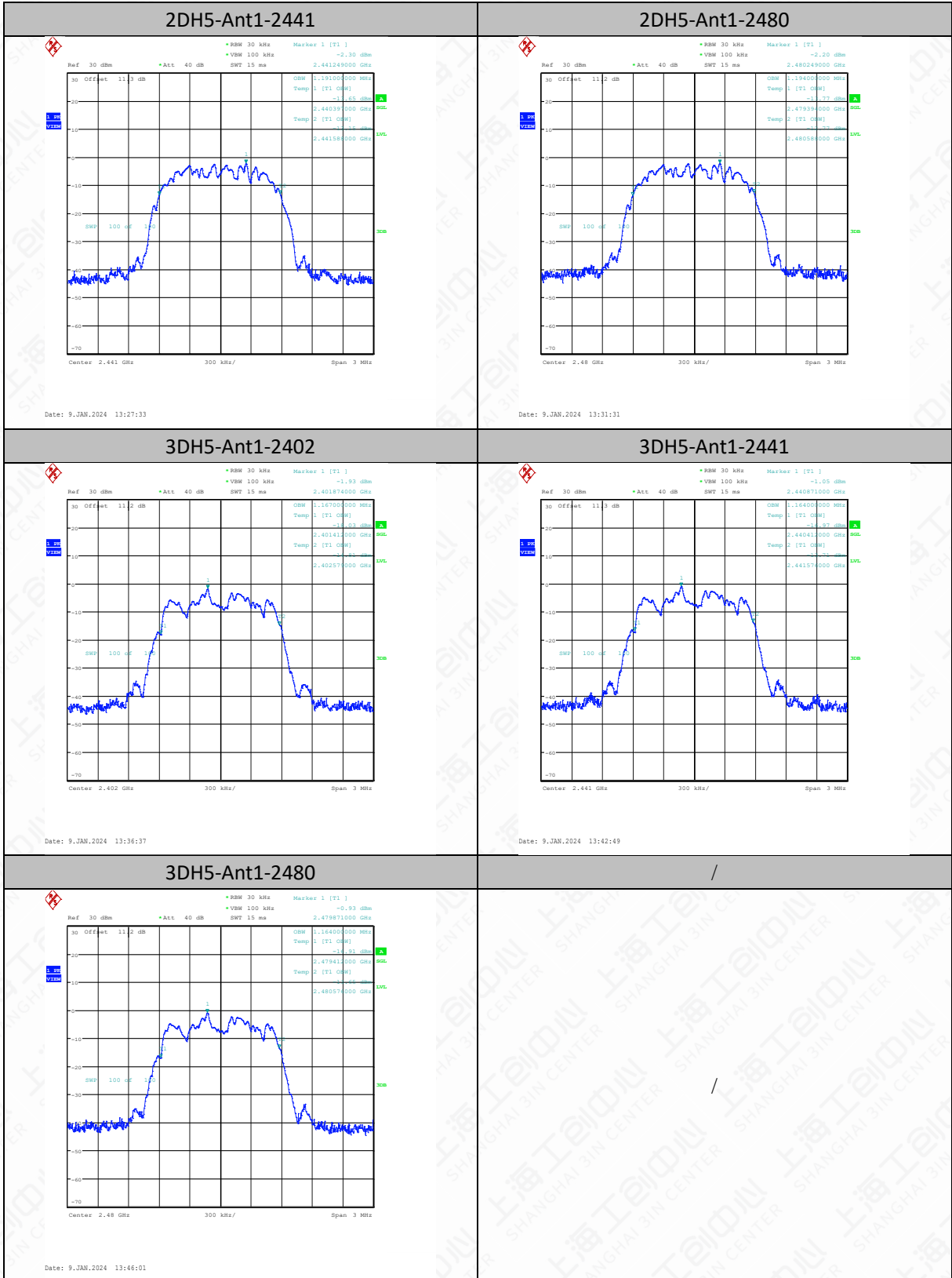

6.8 Carrier Frequency Separation

6.8.1 Measurement Limit

Standard	Limit(KHz)
FCC 47 Part 15.247 (a) (1)	GFSK: Over 25kHz or 20dB bandwidth $\pi/4$ DQPSK; 8DPSK: Over 25kHz or $(2/3)*20$ dB bandwidth
RSS-247 5.1	GFSK: Over 25kHz or 20dB bandwidth $\pi/4$ DQPSK; 8DPSK: Over 25kHz or $(2/3)*20$ dB bandwidth

6.8.2 Test procedures

The measurement is according to ANSI C63.10 clause 7.8.2.

1. Connect the EUT through cable and divide and spectrum analyzer.
2. Enable the EUT transmit in hopping mode.
3. Span: Wide enough to capture the peaks of two adjacent channels.
4. RBW: Start with the RBW set to approximately 30% of the channel spacing; adjust as necessary to best identify the center of each individual channel.
5. Video (or average) bandwidth (VBW) \geq RBW.
6. Sweep: Auto.
7. Detector function: Peak.
8. Trace: Max hold.
9. Allow the trace to stabilize.

6.8.3 Test Setup

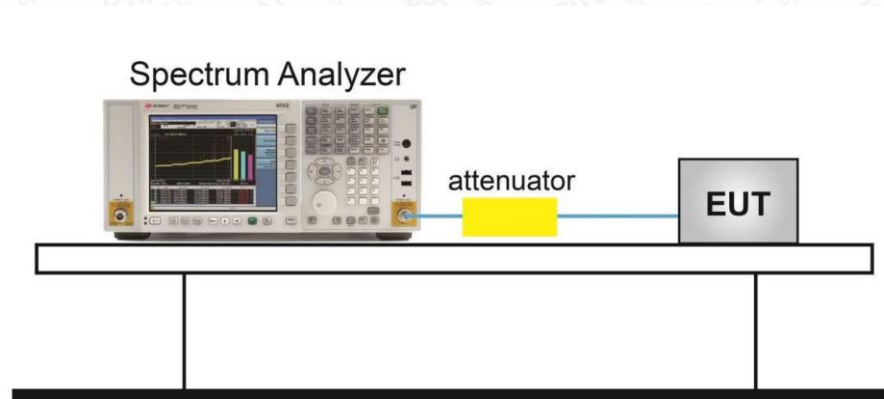

6.8.4 Measurement Result

TestMode	Antenna	Frequency[MHz]	Result[MHz]	Limit[MHz]	Verdict
DH5	Ant1	Hop	0.997	≥0.693	PASS
2DH5	Ant1	Hop	0.99	≥0.907	PASS
3DH5	Ant1	Hop	1.356	≥1.300	PASS

Test Graphs

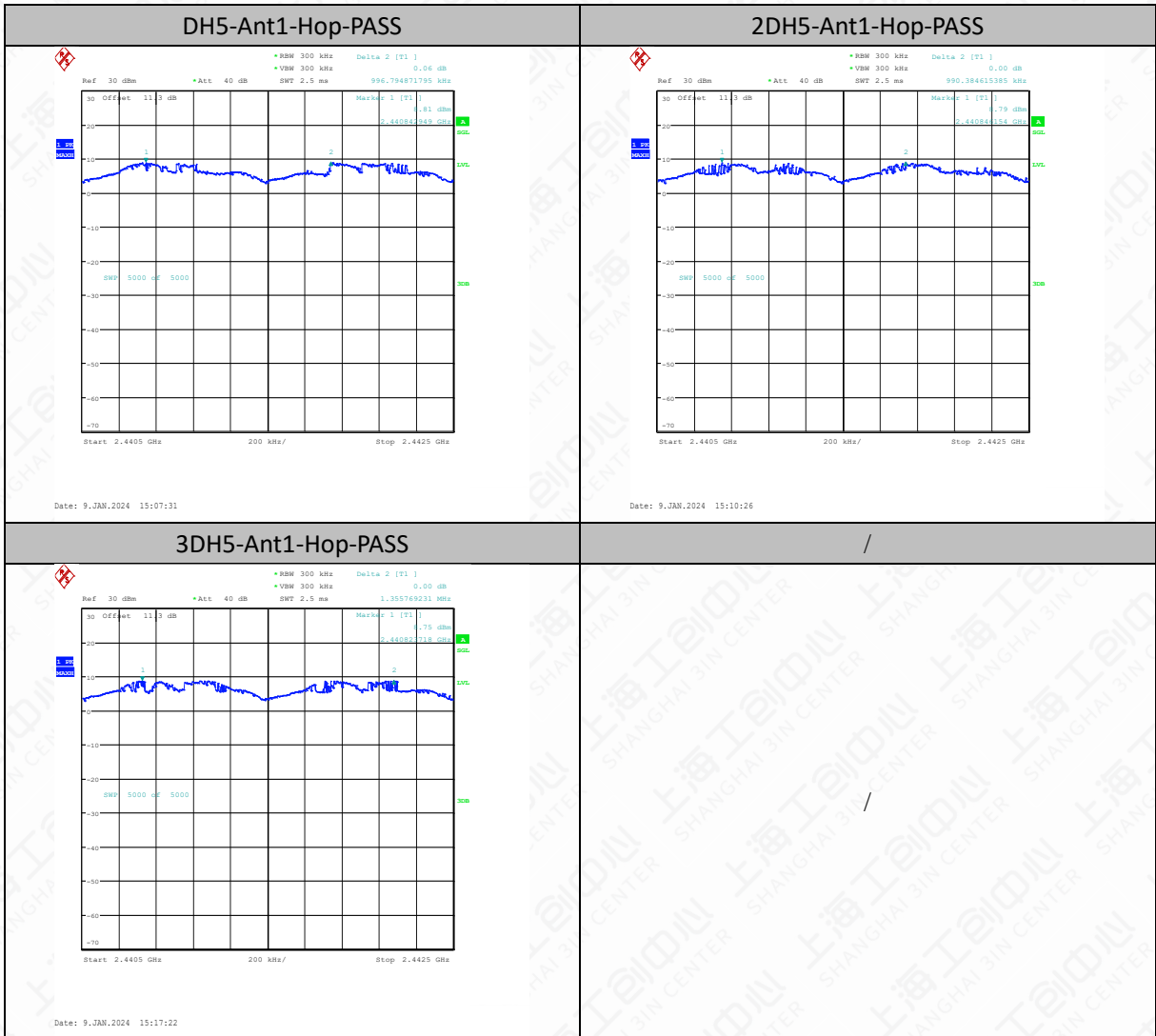

6.9 Number Of Hopping Channels

6.9.1 Measurement Limit

Standard	Limit
FCC 47 CFR Part 15.247 (a)(1)(iii)	At least 15 non-overlapping channels
RSS-247 5.1	At least 15 non-overlapping channels

6.9.2 Test procedure

The measurement is according to ANSI C63.10 clause 7.8.3.

1. Connect the EUT through cable and divide with CMW270 and spectrum analyzer.
2. Enable the EUT transmit in hopping mode.
3. Span: The frequency band of operation. Depending on the number of channels the device supports, it may be necessary to divide the frequency range of operation across multiple spans, to allow the individual channels to be clearly seen.
4. RBW: To identify clearly the individual channels, set the RBW to less than 30% of the channel spacing or the 20 dB bandwidth, whichever is smaller.
5. VBW \geq RBW.
6. Sweep: Auto.
7. Detector function: Peak.
8. Trace: Max hold.
9. Allow the trace to stabilize.
10. Record the test results.

6.9.3 Test Setup

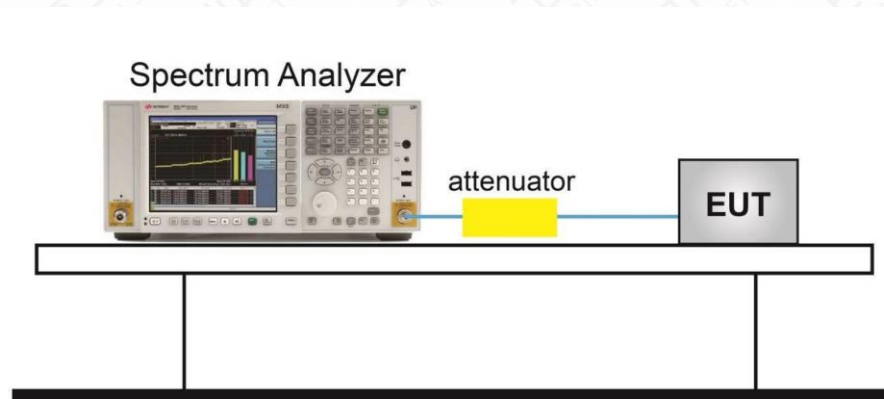

6.9.4 Measurement Result

TestMode	Antenna	Frequency[MHz]	Result[Num]	Limit[Num]	Verdict
DH5	Ant1	Hop	79	≥ 15	PASS
2DH5	Ant1	Hop	79	≥ 15	PASS
3DH5	Ant1	Hop	79	≥ 15	PASS

Test Graphs

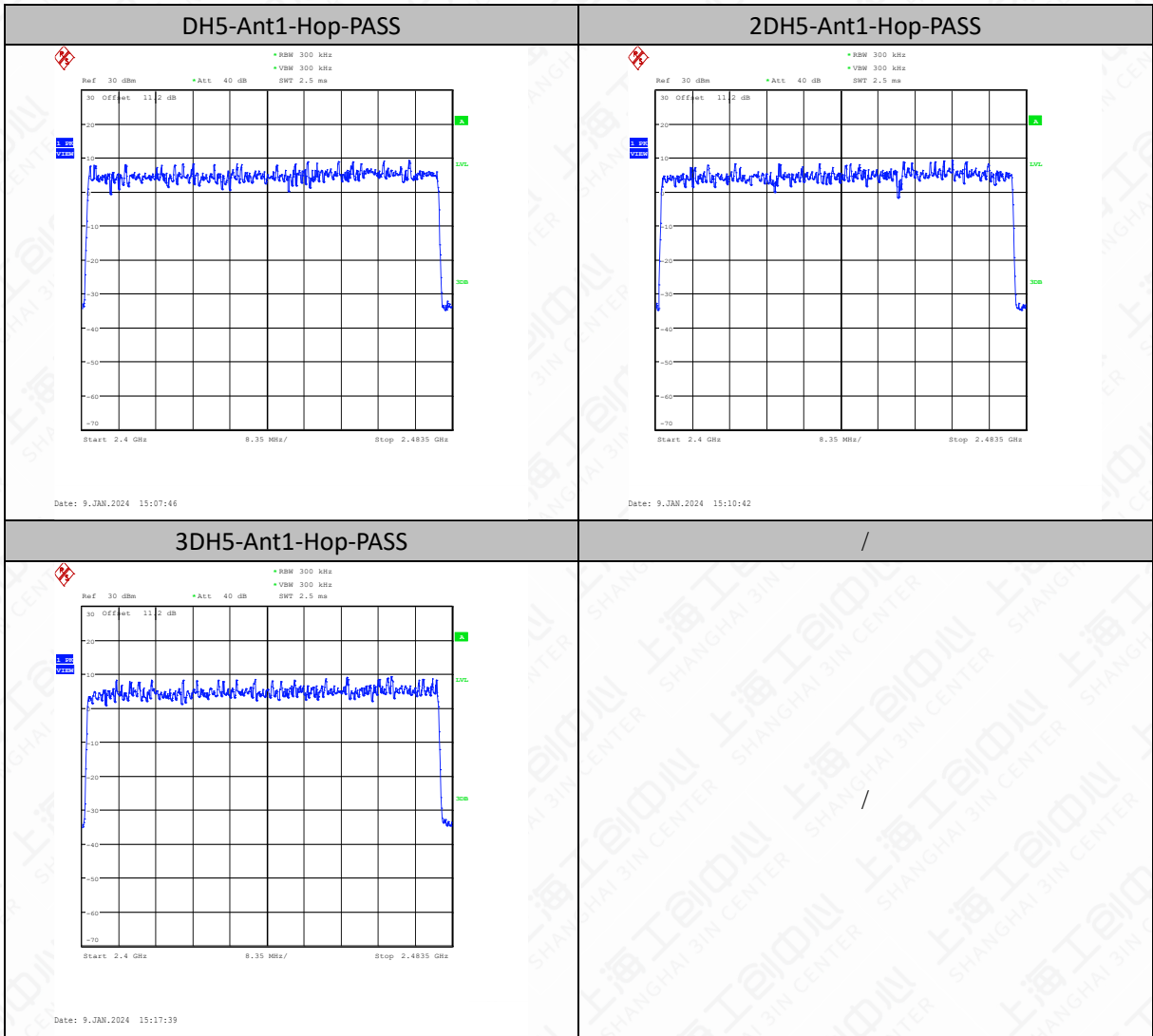

6.10 AC Powerline Conducted Emission

6.10.1 Method of Measurement: ANSI C63.10-2013-clause 6.2

1. The one EUT cable configuration and arrangement and mode of operation that produced the emission with the highest amplitude relative to the limit is selected for the final measurement, while applying the appropriate modulating signal to the EUT.
2. If the EUT is relocated from an exploratory test site to a final test site, the highest emissions shall be remaximized at the final test location before final ac power-line conducted emission measurements are performed.
3. The final test on all current-carrying conductors of all of the power cords to the equipment that comprises the EUT (but not the cords associated with other non-EUT equipment in the system) is then performed for the full frequency range for which the EUT is being tested for compliance without further variation of the EUT arrangement, cable positions, or EUT mode of operation.
4. If the EUT is comprised of equipment units that have their own separate ac power connections, e.g., floor-standing equipment with independent power cords for each shelf that are able to connect directly to the ac power network, each current-carrying conductor of one unit is measured while the other units are connected to a second (or more) LISN(s). All units shall be separately measured. If a power strip is provided by the manufacturer, to supply all of the units making up the EUT, only the conductors in the power cord of the power strip shall be measured.

If the EUT uses a detachable antenna, these measurements shall be made with a suitable dummy load connected to the antenna output terminals; otherwise, the tests shall be made with the antenna connected and, if adjustable, fully extended. When measuring the ac conducted emissions from a device that operates between 150 kHz and 30 MHz a non-detachable antenna may be replaced with a dummy load for the measurements within the fundamental emission band of the transmitter, but only for those measurements.³⁶ Record the six highest EUT emissions relative to the limit of each of the current-carrying conductors of the power cords of the equipment that comprises the EUT over the frequency range specified by the procuring or regulatory agency. Diagram or photograph the test setup that was used. See Clause 8 for full reporting requirements.

6.10.2 Test Setup

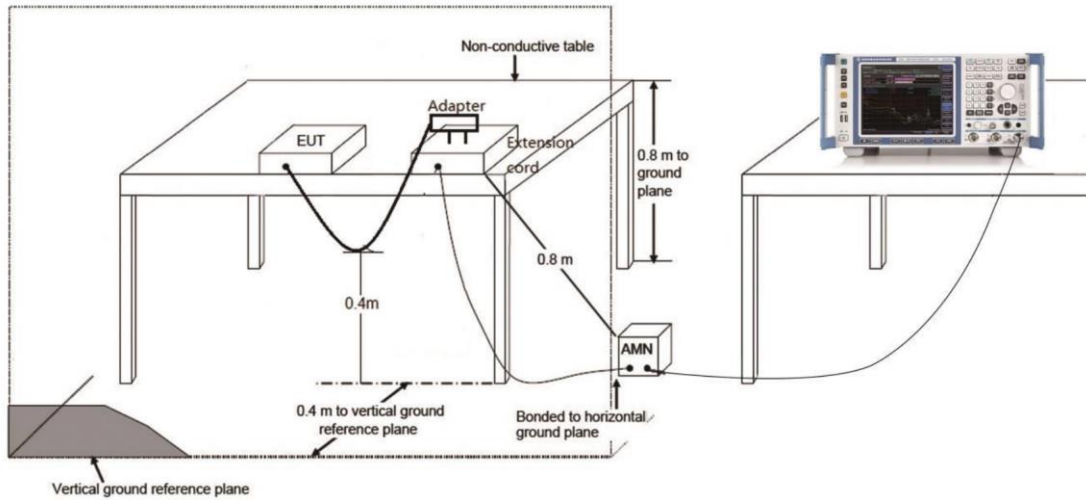

6.10.3 Test Condition

Voltage (V)	Frequency (Hz)
120	60

6.10.4 Measurement limit

(Quasi-peak-average Limit)

Frequency range (MHz)	Quasi-peak Limit (dB μ V)	Average Limit (dB μ V)	Conclusion
0.15 to 0.5	66 to 56	56 to 46	P
0.5 to 5	56	46	
5 to 30	60	50	

NOTE: The limit decreases linearly with the logarithm of the frequency in the range 0.15 MHz to 0.5 MHz.

6.10.5 Measurement Result

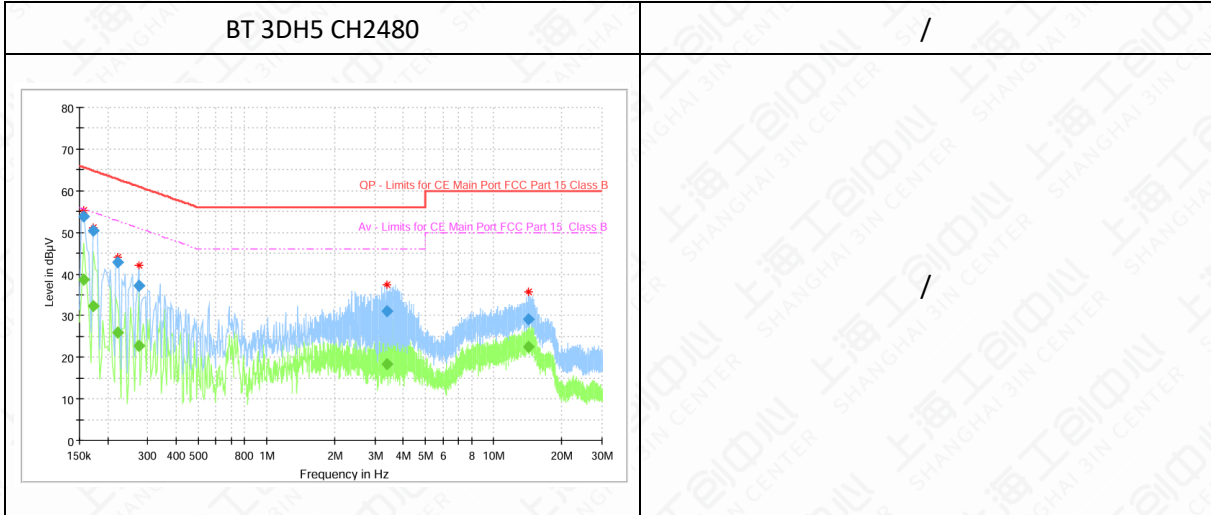

Frequency (MHz)	QuasiPeak (dBµV)	Average (dBµV)	Limit (dBµV)	Margin (dB)	Meas.Time (ms)	Bandwidth (kHz)	Line	Filter	Corr. (dB)
0.157463	---	38.66	55.60	16.93	15000.0	9.000	L1	ON	9.6
0.157463	53.94	---	65.60	11.66	15000.0	9.000	L1	ON	9.6
0.172388	---	32.22	54.85	22.62	15000.0	9.000	L1	ON	9.6
0.172388	50.34	---	64.85	14.50	15000.0	9.000	L1	ON	9.6
0.220894	---	25.84	52.79	26.95	15000.0	9.000	L1	ON	9.6
0.220894	42.71	---	62.79	20.08	15000.0	9.000	L1	ON	9.6
0.273131	---	22.82	51.02	28.20	15000.0	9.000	L1	ON	9.6
0.273131	37.16	---	61.02	23.86	15000.0	9.000	L1	ON	9.6
3.381263	---	18.28	46.00	27.72	15000.0	9.000	L1	ON	9.6
3.381263	31.18	---	56.00	24.82	15000.0	9.000	L1	ON	9.6
14.306363	---	22.47	50.00	27.53	15000.0	9.000	L1	ON	9.9
14.306363	29.03	---	60.00	30.97	15000.0	9.000	L1	ON	9.9

Note: All modes have been tested and only the worst mode is recorded in the report.

Annex A: Revised History

Version	Revised Content
V00	Initial

Annex B: Accreditation Certificate



S2CC 检测项目申请表 (通信产品) .:



Accredited Laboratory

A2LA has accredited

INDUSTRIAL INTERNET INNOVATION CENTER (SHANGHAI) CO., LTD.

Shanghai, People's Republic of China

for technical competence in the field of

Electrical Testing

This laboratory is accredited in accordance with the recognized International Standard ISO/IEC 17025:2017 *General requirements for the competence of testing and calibration laboratories*. This accreditation demonstrates technical competence for a defined scope and the operation of a laboratory quality management system (refer to joint ISO-ILAC-IAF Communiqué dated April 2017).



Presented this 20th day of September 2023.



Mr. Trace McInturff, Vice President, Accreditation Services
For the Accreditation Council
Certificate Number 3682.01
Valid to February 28, 2025

For the tests to which this accreditation applies, please refer to the laboratory's Electrical Scope of Accreditation.

END OF REPORT