

# TEST REPORT

**FCC ID: 2AGLX-DONGLE**  
**Product: USB WIFI Adapter**  
**Model No.: FX-5370**  
**Additional Model No.: N/A**  
**Trade Mark: N/A**  
**Report No.: TCT151117E023**  
**Issued Date: Dec. 22, 2015**

Issued for:

**Piper, Inc.**

**C/O Piper 650, Townsend Street, San Francisco, CA, United States**

Issued By:

**Shenzhen Tongce Testing Lab**

**1F, Leinuo Watch Building, Fuyong Town, Baoan Dist, Shenzhen, China**

**TEL: +86-755-27673339**

**FAX: +86-755-27673332**

**Note:** This report shall not be reproduced except in full, without the written approval of Shenzhen Tongce Testing Lab.

This document may be altered or revised by Shenzhen Tongce Testing Lab. personnel only, and shall be noted in the revision section of the document. The test results in the report only apply to the tested sample.

**TABLE OF CONTENTS**

1. TEST CERTIFICATION.....3

2. TEST RESULT SUMMARY.....4

3. EUT DESCRIPTION.....5

4. TEST METHODOLOGY.....6

    4.1. Decision of Final Test Mode.....6

    4.2. EUT System Operation.....6

5. SETUP OF EQUIPMENT UNDER TEST.....7

    5.1. Description of Support Units.....7

    5.2. Configuration of System Under Test.....7

6. FACILITIES AND ACCREDITATIONS.....8

    6.1. Facilities.....8

    6.2. Measurement Uncertainty.....8

7. EMISSION TEST.....9

    7.1. Conducted Emission at Mains Terminals.....9

    7.2. Radiated Emission.....13

8. PHOTOGRAPHS OF TEST CONFIGURATION.....21

9. PHOTOGRAPHS OF EUT.....23

## 1. Test Certification

<b>Product:</b>	USB WIFI Adapter
<b>Model No.:</b>	FX-5370
<b>Applicant:</b>	Piper, Inc.
<b>Address:</b>	C/O Piper 650, Townsend Street, San Francisco, CA, United States
<b>Manufacturer:</b>	Shenzhen Eastech Company Limited
<b>Address:</b>	No.507, Haoxiang Mingyuan, Shayiweizai New Village, Shajing, Bao'an District, Shenzhen
<b>Test Voltage:</b>	AC 120 V/60 Hz
<b>Date of Test:</b>	Dec. 21, 2015~ Dec. 22, 2015
<b>Applicable Standards:</b>	47 CFR FCC Part 15 Subpart B: 2014 ANSI C63.4: 2014

The above equipment has been tested by Shenzhen Tongce Testing Lab and found compliance with the requirements set forth in the technical standards mentioned above. The results of testing in this report apply only to the product/system, which was tested. Other similar equipment will not necessarily produce the same results due to production tolerance and measurement uncertainties.

Tested By:



SKY

Date:

Dec. 22, 2015

Check By:



Joe Zhou

Date:

Dec. 22, 2015

Approved By:



Tomsin

Date:

Dec. 22, 2015

## 2. Test Result Summary

Emission		
Test Method	Item	Result
FCC 47 CFR Part 15 Subpart B	Conducted Emission at Mains Terminals	Pass
	Radiated Emission	Pass

**Note:**

1. Pass: Test item meets the requirement.
2. Fail: Test item does not meet the requirement.
3. N/A: Test case does not apply to the test object.
4. The test result judgment is decided by the limit of test standard.
5. The information of measurement uncertainty is available upon the customer's request.

### 3. EUT Description

<b>Product Name:</b>	USB WIFI Adapter
<b>Model :</b>	FX-5370
<b>Additional Model:</b>	N/A
<b>Trade Mark:</b>	N/A
<b>Operation Frequency:</b>	2412MHz~2462MHz (802.11b/802.11g/802.11n(HT20)) 2422MHz~2452MHz (802.11n(HT40))
<b>Channel Separation:</b>	5MHz
<b>Number of Channel:</b>	11 for 802.11b/802.11g/802.11n(HT20) 7 for 802.11n(HT40)
<b>Modulation Technology: (IEEE 802.11b)</b>	Direct Sequence Spread Spectrum (DSSS)
<b>Modulation Technology: (IEEE 802.11g/802.11n)</b>	Orthogonal Frequency Division Multiplexing(OFDM)
<b>Data speed (IEEE 802.11b):</b>	1Mbps, 2Mbps, 5.5Mbps, 11Mbps
<b>Data speed (IEEE 802.11g):</b>	6Mbps, 9Mbps, 12Mbps, 18Mbps, 24Mbps, 36Mbps, 48Mbps, 54Mbps
<b>Data speed (IEEE 802.11n):</b>	Up to 150Mbps
<b>Antenna Type:</b>	Internal Antenna
<b>Antenna Gain:</b>	1dBi
<b>Power Supply:</b>	DC 5V from USB Port

## 4. Test Methodology

### 4.1. Decision of Final Test Mode

The EUT was tested together with the thereafter additional components, and a configuration, which produced the worst emission levels, was selected and recorded in this report.

The following test mode(s) were assessed:

Test Mode
Ping mode (ping with router)

### 4.2. EUT System Operation

1. Set up EUT with the support equipments.
2. Make sure the EUT work normally during the test.

## 5. Setup of Equipment under Test

### 5.1. Description of Support Units

The EUT has been tested as an independent unit together with other necessary accessories or support units. The following support units or accessories were used to form a representative test configuration during the tests.

Equipment	Model No.	Serial No.	FCC ID	Trade Name
PC	BM6620	D1PFCG008H P	/	ASUS
Monitor	VX239	VX239H	/	ASUS
Keyboard	PK1100UE	04G10418003 9DP	/	ASUS
Printer	L11121E	FE2-2902	/	CANON
Mouse	MOBTUO	04G12561017 0DP	/	ASUS
Wireless Router	WNR1000v4	/	PY314200269	NETGEAR

**Note:**

1. All the equipment/cables were placed in the worst-case configuration to maximize the emission during the test.
2. Grounding was established in accordance with the manufacturer's requirements and conditions for the intended use.

### 5.2. Configuration of System Under Test

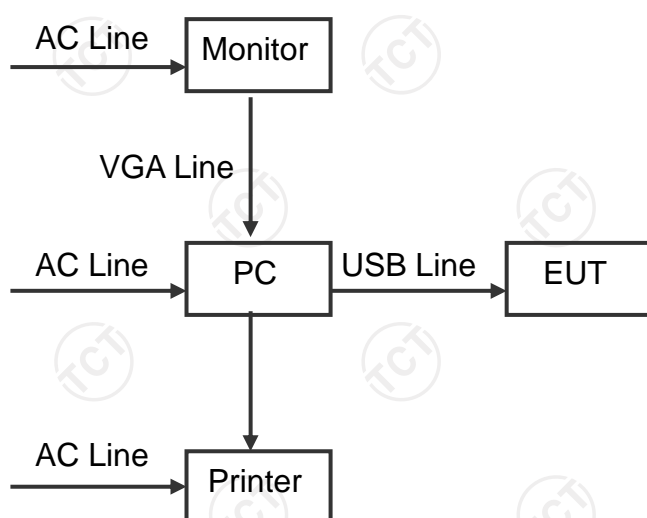

(EUT: USB WIFI Adapter)

## 6. Facilities and Accreditations

### 6.1. Facilities

All measurement facilities used to collect the measurement data are located at TCT Lab.

The sites are constructed in conformance with the requirements of ANSI C63.4 and CISPR Publication 22. All receiving equipment conforms to CISPR Publication 16-1, "Radio Interference Measuring Apparatus and Measurement Methods."

### 6.2. Measurement Uncertainty

Where relevant, the following measurement uncertainty levels have been estimated for tests performed on the EUT as specified in CISPR 16-4-2:

No.	Item	MU
1.	Temperature	$\pm 0.1^{\circ}\text{C}$
2.	Humidity	$\pm 1.0\%$
3.	Spurious Emissions, Conducted	$\pm 2.56\text{ dB}$
4.	All Emissions, Radiated	$\pm 4.28\text{ dB}$

This uncertainty represents an expanded uncertainty expressed at approximately the 95 % confidence level using a coverage factor of  $k=2$ .



## 7. Emission Test

### 7.1. Conducted Emission at Mains Terminals

#### 7.1.1. Test Specification

<b>Test Requirement:</b>	FCC 47 CFR Part 15 Subpart B
<b>Test Method:</b>	ANSI C63.4:2014
<b>Frequency Range:</b>	150 kHz to 30 MHz

#### 7.1.2. Limits

Frequency (MHz)	Class B dB(uV)	
	Quasi-peak	Average
0.15 - 0.5	66 – 56 <sup>a</sup>	56 – 46 <sup>a</sup>
0.50 - 5.0	56	46
5.0 - 30.0	60	50

a. Decreases with the logarithm of the frequency

#### 7.1.3. Test Instruments

Conducted Emission Shielding Room Test Site (843)				
Equipment	Manufacturer	Model	Serial Number	Calibration Due
EMI Test Receiver	R&S	ESCS30	100139	Sep. 11, 2016
LISN	Schwarzbeck	NSLK 8126	8126453	Sep. 16, 2016

**Note:** The calibration interval of the above test instruments is 12 months and the calibrations are traceable to international system unit (SI).

#### 7.1.4. Test Method

The AMN was placed 0.8 m from the boundary of the unit under test and bonded to a ground reference plane. This distance was between the closest points of the AMN and the EUT. All other units of the EUT and associated equipment was at least 0.8 m from the AMN. All power was connected to the system through Artificial Mains Network (AMN). Conducted voltage measurements on mains lines were made at the output of the AMN

#### 7.1.5. Block Diagram of Test Setup

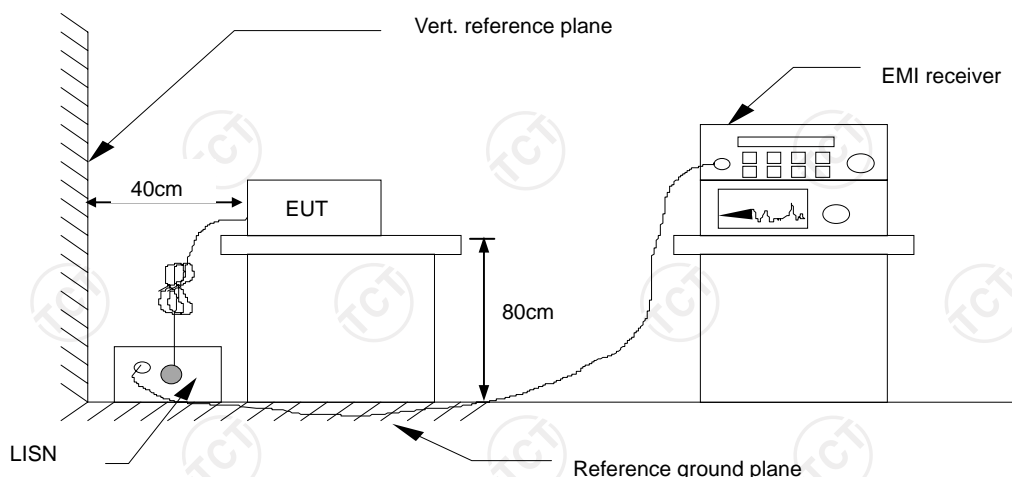

For the actual test configuration, please refer to the related item – Photographs of the Test Configuration.

### 7.1.6. Test Results

<b>Test Environment:</b>	Temp.: 22 °C	Humid.: 54 %	Press.: 96 kPa
<b>Test Mode:</b>	Ping Mode		
<b>Test Voltage:</b>	AC 120 V/60 Hz (for PC)		
<b>Test Result:</b>	Pass		

**Note:**

L1 = Live Line / N = Neutral Line

“---” denotes the emission level was or more than 2dB below the Average limit, so no re-check anymore.

Freq. = Emission frequency in MHz

Reading level dB(μV) = Receiver reading

Corr. Factor (dB) = Attenuator factor + Cable loss

Level dB(μV) = Reading level dB(μV) + Corr. Factor (dB)

Limit dB(μV) = Limit stated in standard

Margin (dB) = Level dB(μV) – Limits dB(μV)

Q.P. =Quasi-Peak

AVG=Average

Please refer to following diagram for individual

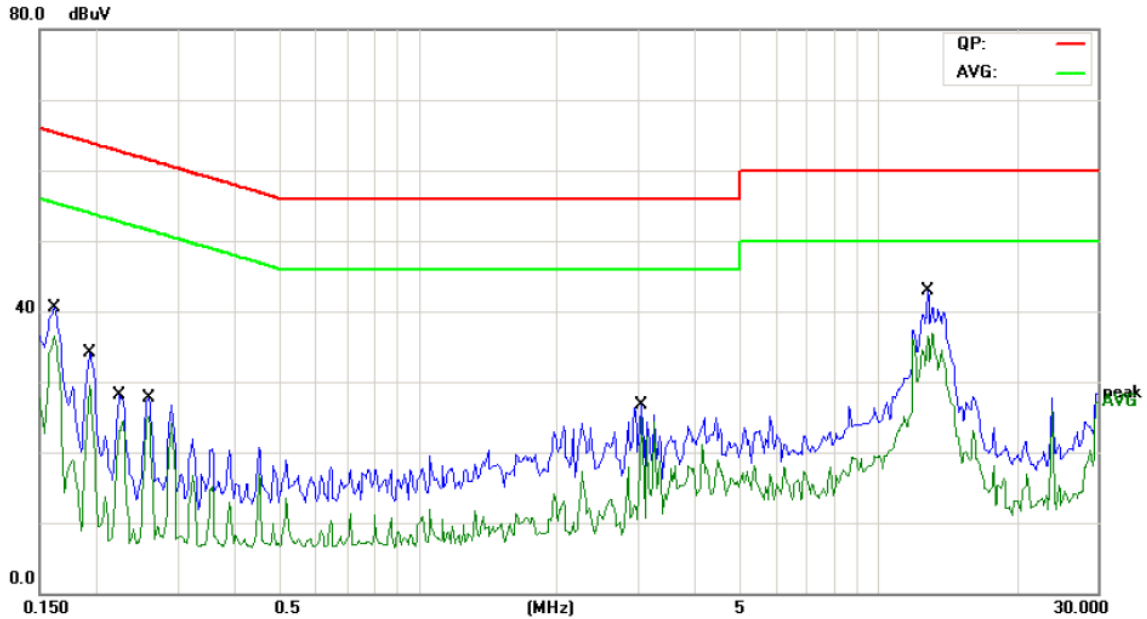

Site Chamber #2 Phase: **L1** Temperature: 23 (C)  
Limit: FCC Part 15B Class B Conduction(QP) Power: AC 120V/60Hz Humidity: 54 %

No. Mk.	Freq. MHz	Reading Level dBuV	Correct Factor dB	Measurement dBuV	Limit dBuV	Over dB	Detector	Comment
1	0.1617	27.58	11.49	39.07	65.37	-26.30	QP	
2	0.1617	25.36	11.49	36.85	55.37	-18.52	AVG	
3	0.1930	19.64	11.46	31.10	63.90	-32.80	QP	
4	0.1930	14.26	11.46	25.72	53.90	-28.18	AVG	
5	0.2242	14.74	11.45	26.19	62.66	-36.47	QP	
6	0.2242	13.04	11.45	24.49	52.66	-28.17	AVG	
7	0.2594	14.55	11.43	25.98	61.45	-35.47	QP	
8	0.2594	13.70	11.43	25.13	51.45	-26.32	AVG	
9	3.0547	12.60	11.30	23.90	56.00	-32.10	QP	
10	3.0547	7.69	11.30	18.99	46.00	-27.01	AVG	
11	12.8242	27.97	11.41	39.38	60.00	-20.62	QP	
12 *	12.8242	23.05	11.41	34.46	50.00	-15.54	AVG	

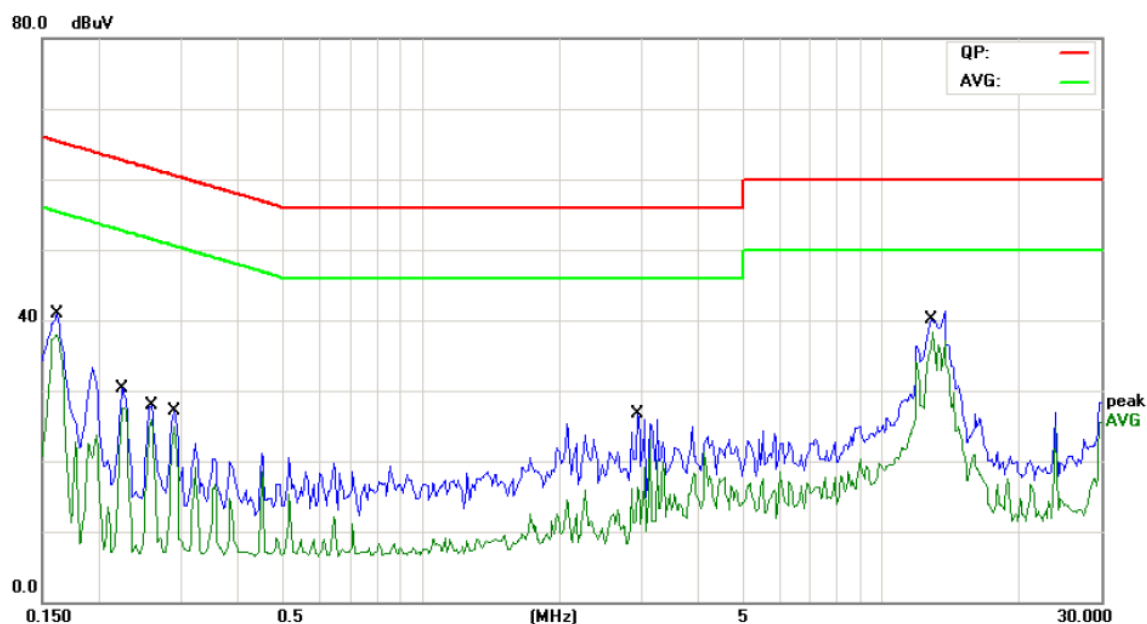

Site Chamber #2 Phase: **N** Temperature: 23 (C)  
 Limit: FCC Part 15B Class B Conduction(QP) Power: AC 120V/60Hz Humidity: 54 %

No. Mk.	Freq. MHz	Reading Level dBuV	Correct Factor dB	Measure- ment dBuV	Limit dBuV	Over dB	Detector	Comment
1	0.1617	28.58	11.49	40.07	65.37	-25.30	QP	
2 *	0.1617	26.98	11.49	38.47	55.37	-16.90	AVG	
3	0.2242	16.75	11.45	28.20	62.66	-34.46	QP	
4	0.2242	15.98	11.45	27.43	52.66	-25.23	AVG	
5	0.2594	15.10	11.43	26.53	61.45	-34.92	QP	
6	0.2594	14.47	11.43	25.90	51.45	-25.55	AVG	
7	0.2906	14.25	11.41	25.66	60.50	-34.84	QP	
8	0.2906	13.57	11.41	24.98	50.50	-25.52	AVG	
9	2.9586	12.45	11.34	23.79	56.00	-32.21	QP	
10	2.9586	6.24	11.34	17.58	46.00	-28.42	AVG	
11	12.9199	25.57	11.42	36.99	60.00	-23.01	QP	
12	12.9199	18.82	11.42	30.24	50.00	-19.76	AVG	

## 7.2. Radiated Emission

### 7.2.1. Test Specification

<b>Test Requirement:</b>	FCC 47 CFR Part 15 Subpart B
<b>Test Method:</b>	ANSI C63.4:2014
<b>Frequency Range:</b>	30 MHz to 1000 MHz
<b>Measurement Distance:</b>	3 m
<b>Antenna Polarization:</b>	Horizontal & Vertical

### 7.2.2. Limits

Frequency (MHz)	Class B (at 3m)
	dBuV/m
30 ~ 88	40.0
88 ~ 216	43.5
216 ~ 960	46.0
960 ~ 1000	54.0

**Note:**

1. The lower limit shall apply at the transition frequencies.
2. Emission level  $\text{dB}(\mu\text{V}/\text{m}) = 20 \log \text{Emission level } (\mu\text{V}/\text{m})$ .

7.2.3. Test Instruments

Radiated Emission Test Site (966)				
Name of Equipment	Manufacturer	Model	Serial Number	Calibration Due
EMI Test Receiver	R&S	ESVD	100008	Sep. 16, 2016
Spectrum Analyzer	R&S	FSEM	848597-001	Sep. 16, 2016
Amplifier	HP	8447D	2727A05017	Sep. 16, 2016
Amplifier	EM	EM30265	07032613	Sep. 16, 2016
Broadband Antenna	Schwarzbeck	VULB9163	340	Sep. 17, 2016
Horn Antenna	Schwarzbeck	BBHA 9120D	631	Sep. 17, 2016
Antenna Mater	CCS	CC-A-4M	N/A	Sep.15 , 2016
Coax cable	TCT	RE-low-01	N/A	Sep.15 , 2016
Coax cable	TCT	RE-high-02	N/A	Sep.15 , 2016
Coax cable	TCT	RE-low-03	N/A	Sep.15 , 2016
Coax cable	TCT	RE-high-04	N/A	Sep.15 , 2016

**Note:** The calibration interval of the above test instruments is 12 months and the calibrations are traceable to international system unit (SI)

**7.2.4. Test Method**

Measurements were made in a 3-meter semi-anechoic chamber or Open Area Test Site that complies to CISPR 16. Preliminary (peak) measurements were performed at an antenna to EUT separation distance of 3 meter. The EUT was rotated 360° about its azimuth with the receive antenna located at various heights in horizontal and vertical polarities. Final measurements (quasi-peak) were then performed by rotating the EUT 360° and adjusting the receive antenna height from 1 to 4 m. All frequencies were investigated in both horizontal and vertical antenna polarity, where applicable. Block Diagram of Test Setup.

**7.2.5. Block Diagram of Test Setup**

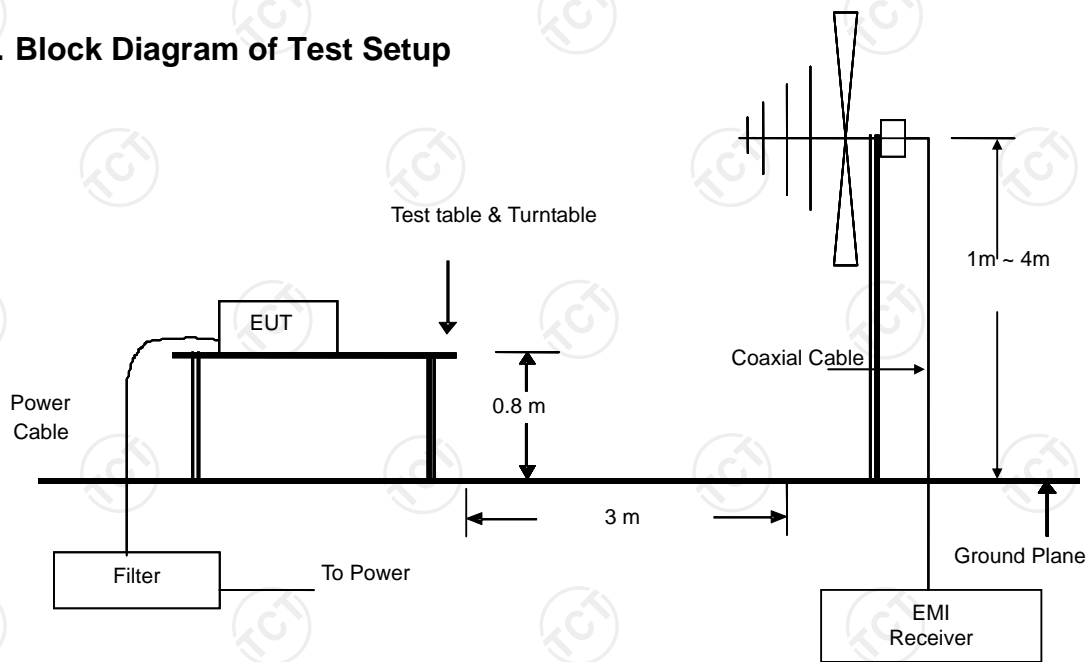

**(30MHz to 1GHz)**

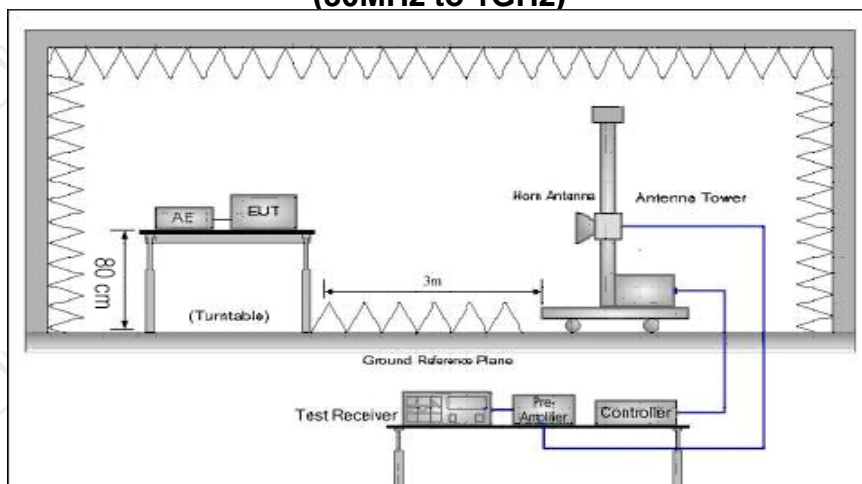

**(Above 1GHz)**

For the actual test configuration, please refer to the related item – Photographs of the Test Configuration

**7.2.6. Test Results**

<b>Test Environment:</b>	Temp.: 23 °C	Humid.: 53 %	Press.: 96 kPa
<b>Test Mode:</b>	Ping mode		
<b>Test Voltage:</b>	AC 120 V/60 Hz(for PC)		
<b>Test Result:</b>	Pass		

**Note:**

Freq. = Emission frequency in MHz

Reading level dB(μV) = Receiver reading

Corr. Factor (dB) = Antenna factor + Cable loss

Measurement dB(μV/m) = Reading level dB(μV) + Corr. Factor (dB)

Limit dB(μV/m) = Limit stated in standard

Margin (dB) = Measurement dB(μV/m) – Limits dB(μV/m)

Q.P. =Quasi-Peak



Please refer to following diagram for individual

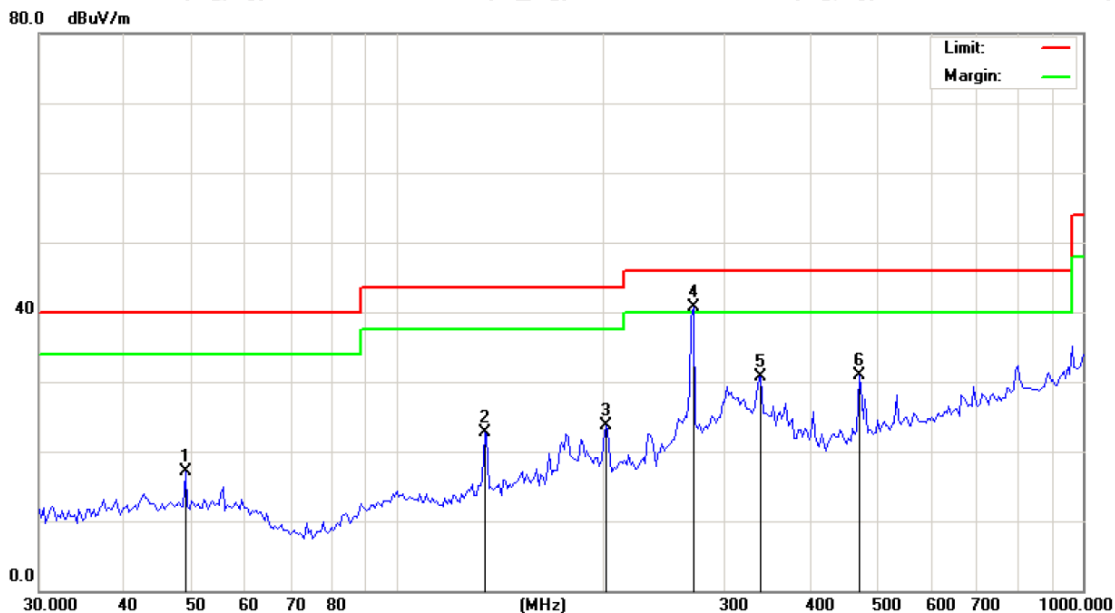

Site: \_\_\_\_\_ Polarization: **Horizontal** Temperature: 23  
 Limit: FCC Part 15B Class B RE\_3 m Power: DC 120V/60Hz Humidity: 54 %

No. Mk.	Freq. MHz	Reading Level dBuV	Correct Factor dB	Measurement dBuV/m	Limit dBuV/m	Over dB	Detector	Antenna Height cm	Table Degree	Comment
1	49.0627	29.21	-12.08	17.13	40.00	-22.87	peak		0	
2	134.0194	37.95	-15.17	22.78	43.50	-20.72	peak		0	
3	201.4540	35.27	-11.62	23.65	43.50	-19.85	peak		0	
4 *	270.6162	49.97	-9.25	40.72	46.00	-5.28	peak		0	
5	338.8546	38.15	-7.45	30.70	46.00	-15.30	peak		0	
6	471.4665	34.86	-3.89	30.97	46.00	-15.03	peak		0	

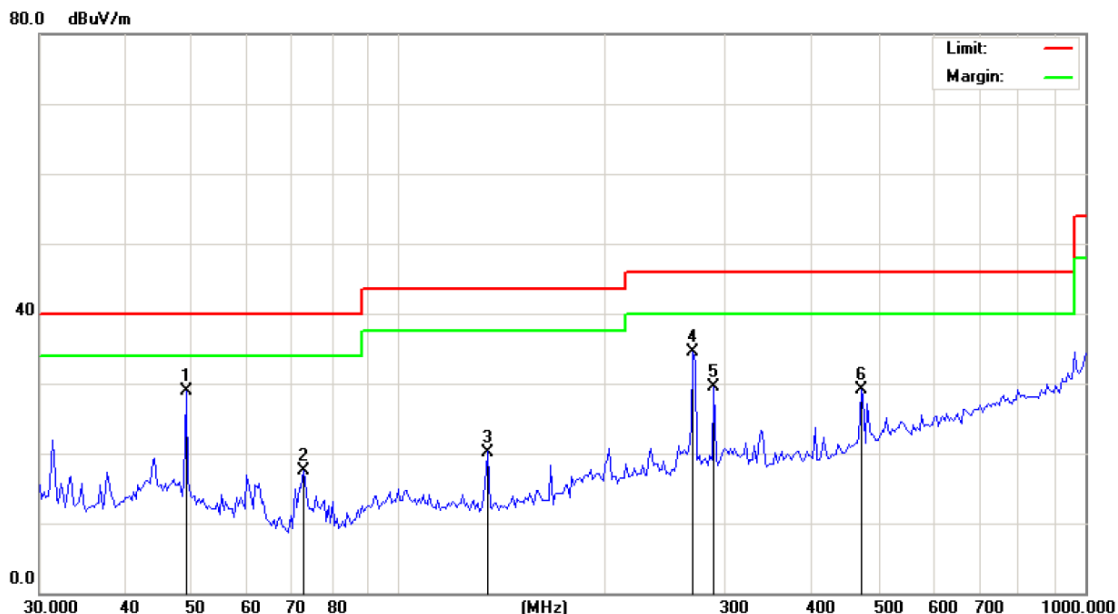

Site: Polarization: **Vertical** Temperature: 23  
 Limit: FCC Part 15B Class B RE\_3 m Power: DC 120V/60Hz Humidity: 54 %

No.	Mk.	Freq. MHz	Reading Level dBuV	Correct Factor dB	Measure- ment dBuV/m	Limit dBuV/m	Over dB	Antenna Height cm	Table Degree	Comment
1	*	49.0627	40.95	-12.08	28.87	40.00	-11.13	peak	0	
2		72.7203	33.91	-16.46	17.45	40.00	-22.55	peak	0	
3		134.9645	35.41	-15.21	20.20	43.50	-23.30	peak	0	
4		268.7212	43.89	-9.32	34.57	46.00	-11.43	peak	0	
5		288.2840	38.20	-8.65	29.55	46.00	-16.45	peak	0	
6		471.4665	33.03	-3.89	29.14	46.00	-16.86	peak	0	

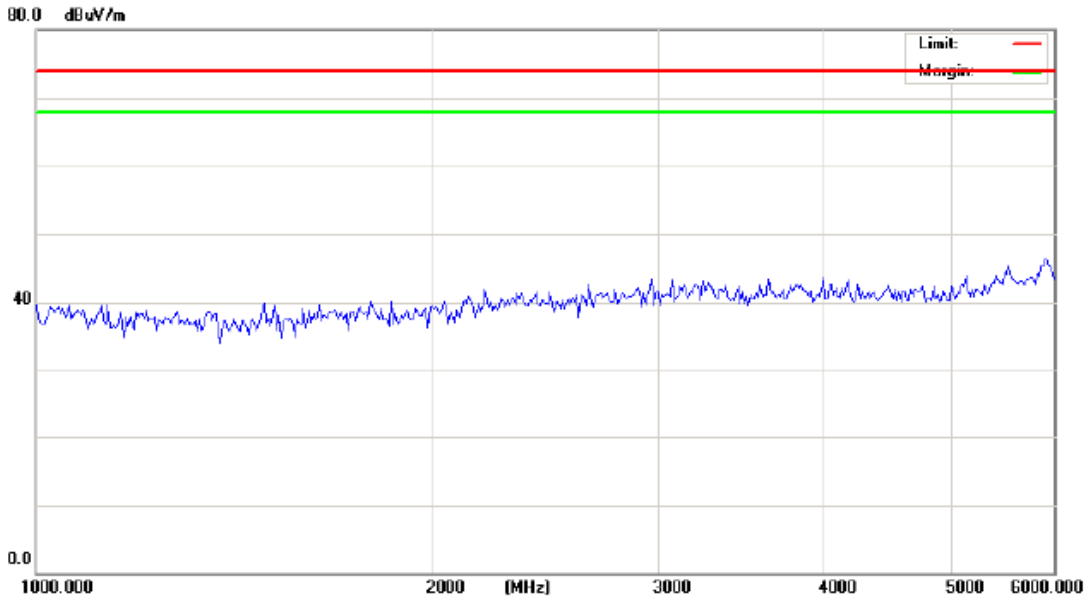

Site: Polarization: **Horizontal** Temperature: 23  
 Limit: FCC ABOVE1G Power: AC 120V/60Hz Humidity: 53 %

No.	Mk.	Freq.	Reading Level	Correct Factor	Measurement	Limit	Over	Antenna Height	Table Degree
		MHz	dBuV	dB	dBuV/m	dBuV/m	dB	cm	degree

Note: Any value more than 10 dB below limit have not been specifically reported.

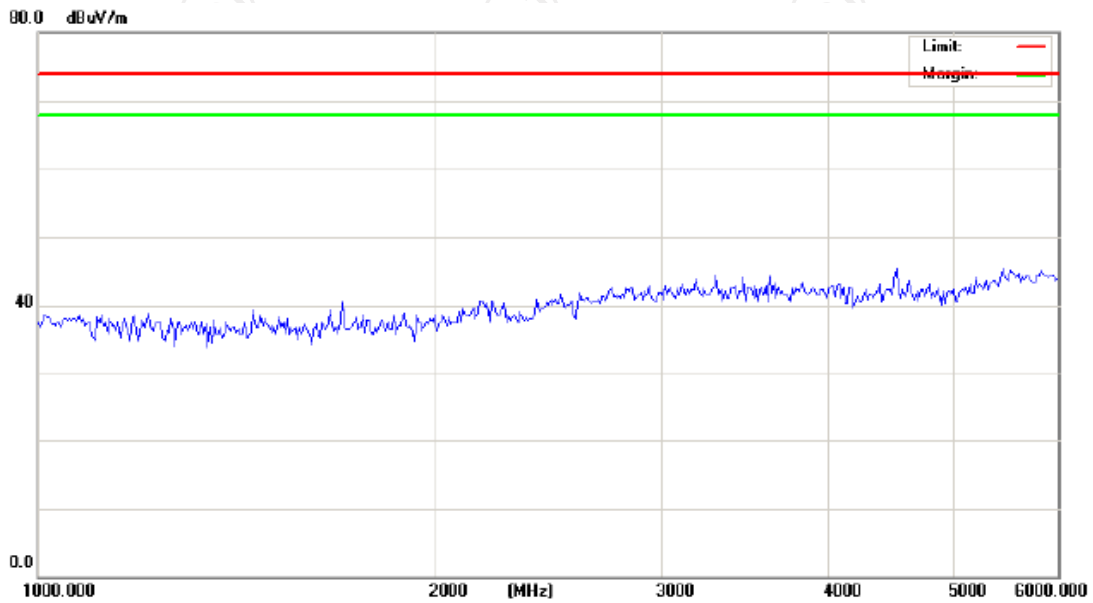

Site: Polarization: **Vertical** Temperature: 23  
 Limit: FCC ABOVE1G Power: AC 120V/60Hz Humidity: 53 %

No.	Mk.	Freq.	Reading Level	Correct Factor	Measurement	Limit	Over	Antenna Height	Table Degree	Comment
		MHz	dBuV	dB	dBuV/m	dBuV/m	dB	Detector	cm	degree

Note: Any value more than 10 dB below limit have not been specifically reported.

## 8. Photographs of Test Configuration

Conducted Emission Test View



Radiated Emission Test View (Below 1 GHz)

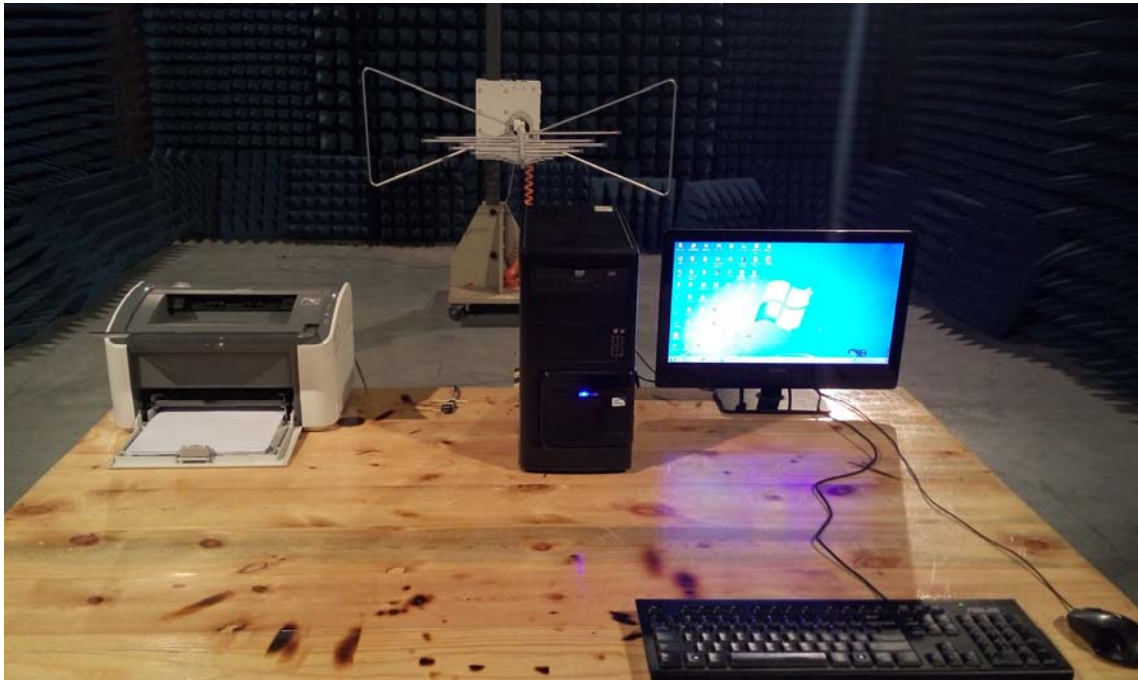

**Radiated Emission Test View (Above 1 GHz)**

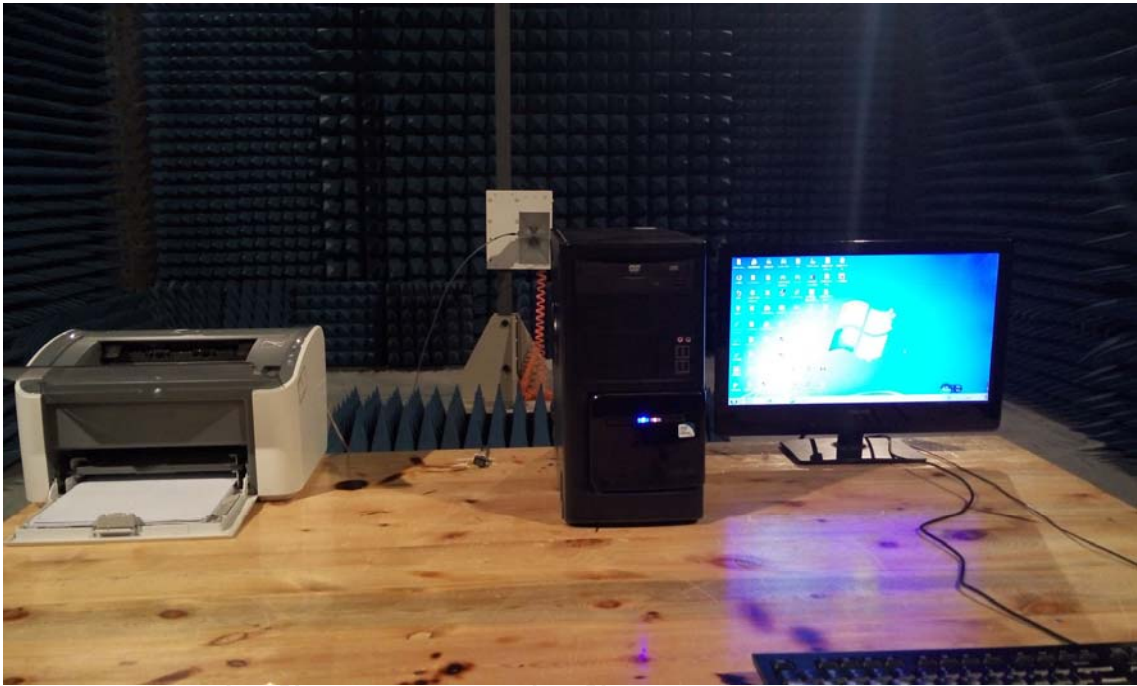

## 9. Photographs of EUT

Refer to test report TCT151117E001

**\*\*\*\*\*END OF REPORT\*\*\*\*\***