

FCC Radio Test Report

FCC ID: 2AFG6-RK3399

This report concerns (check one): Original Grant Class I Change Class II Change

Project No. : 1703C059
Equipment : Android Module
Model Name : RK3399
Applicant : Guangzhou Shirui Electronics Co.,Ltd
Address : 192 Kezhu Road, Sciencetech Park, Guangzhou
Economic & Technology Development District,
Guangzhou,Guangdong,China

Date of Receipt : Mar. 08, 2017
Date of Test : Mar. 08, 2017 ~ Apr. 20, 2017
Issued Date : Apr. 21, 2017
Tested by : BTL Inc.

Testing Engineer : Shawn Xiao
(Shawn Xiao)

Technical Manager : David Mao
(David Mao)

Authorized Signatory : Steven Lu
(Steven Lu)

B T L I N C .

No.3, Jinshagang 1st Road, Shixia, Dalang Town, Dongguan,
Guangdong, China.

TEL: +86-769-8318-3000 FAX: +86-769-8319-6000

Declaration

BTL represents to the client that testing is done in accordance with standard procedures as applicable and that test instruments used has been calibrated with standards traceable to international standard(s) and/or national standard(s).

BTL's reports apply only to the specific samples tested under conditions. It is manufacture's responsibility to ensure that additional production units of this model are manufactured with the identical electrical and mechanical components. **BTL** shall have no liability for any declarations, inferences or generalizations drawn by the client or others from **BTL** issued reports.

BTL's report must not be used by the client to claim product certification, approval, or endorsement by NVLAP, NIST, or any agency of the Federal Government.

This report is the confidential property of the client. As a mutual protection to the clients, the public and **BTL-self**, extracts from the test report shall not be reproduced except in full with **BTL's** authorized written approval.

BTL's laboratory quality assurance procedures are in compliance with the **ISO Guide 17025** requirements, and accredited by the conformity assessment authorities listed in this test report.

Limitation

For the use of the authority's logo is limited unless the Test Standard(s)/Scope(s)/Item(s) mentioned in this test report is (are) included in the conformity assessment authorities acceptance respective.

| Table of Contents | Page |
|--|-----------|
| 1 . CERTIFICATION | 6 |
| 2 . SUMMARY OF TEST RESULTS | 7 |
| 2.1 TEST FACILITY | 8 |
| 2.2 MEASUREMENT UNCERTAINTY | 8 |
| 3 . GENERAL INFORMATION | 9 |
| 3.1 GENERAL DESCRIPTION OF EUT | 9 |
| 3.2 DESCRIPTION OF TEST MODES | 10 |
| 3.3 TABLE OF PARAMETERS OF TEXT SOFTWARE SETTING | 10 |
| 3.4 BLOCK DIAGRAM SHOWING THE CONFIGURATION OF SYSTEM TESTED | 11 |
| 3.5 DESCRIPTION OF SUPPORT UNITS | 11 |
| 4 . EMC EMISSION TEST | 12 |
| 4.1 CONDUCTED EMISSION MEASUREMENT | 12 |
| 4.1.1 POWER LINE CONDUCTED EMISSION LIMITS | 12 |
| 4.1.2 TEST PROCEDURE | 12 |
| 4.1.3 DEVIATION FROM TEST STANDARD | 12 |
| 4.1.4 TEST SETUP | 13 |
| 4.1.5 EUT OPERATING CONDITIONS | 13 |
| 4.1.6 EUT TEST CONDITIONS | 13 |
| 4.1.7 TEST RESULTS | 13 |
| 4.2 RADIATED EMISSION MEASUREMENT | 14 |
| 4.2.1 RADIATED EMISSION LIMITS | 14 |
| 4.2.2 TEST PROCEDURE | 15 |
| 4.2.3 DEVIATION FROM TEST STANDARD | 15 |
| 4.2.4 TEST SETUP | 16 |
| 4.2.5 EUT OPERATING CONDITIONS | 17 |
| 4.2.6 EUT TEST CONDITIONS | 17 |
| 4.2.7 TEST RESULTS (9KHZ TO 30MHZ) | 17 |
| 4.2.8 TEST RESULTS (30MHZ TO 1000 MHZ) | 17 |
| 4.2.9 TEST RESULTS (ABOVE 1000 MHZ) | 17 |
| 5 . BANDWIDTH TEST | 18 |
| 5.1 APPLIED PROCEDURES / LIMIT | 18 |
| 5.1.1 TEST PROCEDURE | 18 |
| 5.1.2 DEVIATION FROM STANDARD | 18 |
| 5.1.3 TEST SETUP | 18 |
| 5.1.4 EUT OPERATION CONDITIONS | 18 |
| 5.1.5 EUT TEST CONDITIONS | 18 |
| 5.1.6 TEST RESULTS | 18 |

| Table of Contents | Page |
|--|-----------|
| 6 . MAXIMUM OUTPUT POWER TEST | 19 |
| 6.1 APPLIED PROCEDURES / LIMIT | 19 |
| 6.1.1 TEST PROCEDURE | 19 |
| 6.1.2 DEVIATION FROM STANDARD | 19 |
| 6.1.3 TEST SETUP | 19 |
| 6.1.4 EUT OPERATION CONDITIONS | 19 |
| 6.1.5 EUT TEST CONDITIONS | 19 |
| 6.1.6 TEST RESULTS | 19 |
| 7 . ANTENNA CONDUCTED SPURIOUS EMISSION | 20 |
| 7.1 APPLIED PROCEDURES / LIMIT | 20 |
| 7.1.1 TEST PROCEDURE | 20 |
| 7.1.2 DEVIATION FROM STANDARD | 20 |
| 7.1.3 TEST SETUP | 20 |
| 7.1.4 EUT OPERATION CONDITIONS | 20 |
| 7.1.5 EUT OPERATION CONDITIONS | 20 |
| 7.1.6 TEST RESULTS | 20 |
| 8 . POWER SPECTRAL DENSITY TEST | 21 |
| 8.1 APPLIED PROCEDURES / LIMIT | 21 |
| 8.1.1 TEST PROCEDURE | 21 |
| 8.1.2 DEVIATION FROM STANDARD | 21 |
| 8.1.3 TEST SETUP | 21 |
| 8.1.4 EUT OPERATION CONDITIONS | 21 |
| 8.1.5 EUT TEST CONDITIONS | 21 |
| 8.1.6 TEST RESULTS | 21 |
| 9 . MEASUREMENT INSTRUMENTS LIST | 22 |
| 10 . EUT TEST PHOTO | 24 |
| ATTACHMENT A - CONDUCTED EMISSION | 28 |
| ATTACHMENT B - RADIATED EMISSION (9KHZ TO 30MHZ) | 31 |
| ATTACHMENT C - RADIATED EMISSION (30MHZ TO 1000MHZ) | 36 |
| ATTACHMENT D - RADIATED EMISSION (ABOVE 1000MHZ) | 43 |
| ATTACHMENT E - BANDWIDTH | 56 |
| ATTACHMENT F - MAXIMUM OUTPUT POWER TEST | 59 |
| ATTACHMENT G - ANTENNA CONDUCTED SPURIOUS EMISSION | 60 |
| ATTACHMENT H - POWER SPECTRAL DENSITY TEST | 67 |

REPORT ISSUED HISTORY

| Issued No. | Description | Issued Date |
|---------------------|-----------------|---------------|
| BTL-FICP-1-1703C059 | Original Issue. | Apr. 21, 2017 |

1. CERTIFICATION

Equipment : Android Module
Brand Name : SEEWO
Model Name : RK3399
Applicant : Guangzhou Shirui Electronics Co.,Ltd
Manufacturer: Guangzhou Shirui Electronics Co.,Ltd
Address : 192 Kezhu Road, Sciencetech Park, Guangzhou Economic & Technology
Development District, Guangzhou,Guangdong,China
Date of Test : Mar. 09, 2017 ~ Apr. 20, 2017
Test Sample : Engineering Sample
Standard(s) : FCC Part15, Subpart C (15.247)
ANSI C63.10-2013

The above equipment has been tested and found compliance with the requirement of the relative standards by BTL Inc.

The test data, data evaluation, and equipment configuration contained in our test report (Ref No. BTL-FCCP-2-1703C059) were obtained utilizing the test procedures, test instruments, test sites that has been accredited by the Authority of TAF according to the ISO-17025 quality assessment standard and technical standard(s).

2. SUMMARY OF TEST RESULTS

Test procedures according to the technical standard(s):

| Applied Standard(s): FCC Part15 (15.247) , Subpart C | | | |
|--|-------------------------------------|----------|--------|
| Standard(s) Section | Test Item | Judgment | Remark |
| 15.207 | Conducted Emission | PASS | |
| 15.247(d) | Antenna conducted Spurious Emission | PASS | |
| 15.247(a)(2) | 6dB Bandwidth | PASS | |
| 15.247(b)(3) | Peak Output Power | PASS | |
| 15.247(e) | Power Spectral Density | PASS | |
| 15.203 | Antenna Requirement | PASS | |
| 15.247(d)/ 15.205/ 15.209 | Transmitter Radiated Emissions | PASS | |

NOTE:

(1) "N/A" denotes test is not applicable to this device.

2.1 TEST FACILITY

The test facilities used to collect the test data in this report is at the location of No.3, Jinshagang 1st Road, Shixia, Dalang Town, Dongguan, Guangdong, China.
 BTL's test firm number for FCC: 319330

2.2 MEASUREMENT UNCERTAINTY

Where relevant, the following measurement uncertainty levels have been estimated for tests performed on the EUT as specified in CISPR 16-4-2. The BTL measurement uncertainty is less than the CISPR 16-4-2 U_{CISPR} requirement.

The reported uncertainty of measurement $y \pm U$, where expanded uncertainty U is based on a standard uncertainty multiplied by a coverage factor of $k=2$, providing a level of confidence of approximately 95 %.

A. Conducted Measurement:

| Test Site | Method | Measurement Frequency Range | U, (dB) |
|-----------|--------|-----------------------------|---------|
| DG-C02 | CISPR | 150 KHz ~ 30MHz | 2.32 |

B. Radiated Measurement:

| Test Site | Method | Measurement Frequency Range | Ant. H / V | U, (dB) |
|-----------|--------|-----------------------------|------------|---------|
| DG-CB03 | CISPR | 9KHz~30MHz | V | 3.79 |
| | | 9KHz~30MHz | H | 3.57 |
| | | 30MHz ~ 200MHz | V | 3.82 |
| | | 30MHz ~ 200MHz | H | 3.78 |
| | | 200MHz ~ 1,000MHz | V | 4.10 |
| | | 200MHz ~ 1,000MHz | H | 4.06 |
| | | 1GHz~18GHz | V | 3.12 |
| | | 1GHz~18GHz | H | 3.68 |
| | | 18GHz~40GHz | V | 4.15 |
| | | 18GHz~40GHz | H | 4.14 |

Note: Unless specifically mentioned, the uncertainty of measurement has not been taken into account to declare the compliance or non-compliance to the specification.

3. GENERAL INFORMATION

3.1 GENERAL DESCRIPTION OF EUT

| | | |
|---------------------|---|------------------|
| Equipment | Android Module | |
| Brand Name | SEEWO | |
| Model Name | RK3399 | |
| Model Difference | N/A | |
| Product Description | Operation Frequency | 2402~2480 MHz |
| | Modulation Technology | GFSK(1Mbps) |
| | Bit Rate of Transmitter | |
| | Output Power (Max.) | 4.92 dBm (1Mbps) |
| Power Source | DC voltage supplied from AC/DC adapter.(Support Unit) | |
| Power Rating | 12/19V 1.5A | |

Note:

- For a more detailed features description, please refer to the manufacturer's specifications or the user's manual.
- Channel List:

| Channel | Frequency (MHz) | Channel | Frequency (MHz) |
|---------|-----------------|---------|-----------------|
| 00 | 2402 | 20 | 2442 |
| 01 | 2404 | 21 | 2444 |
| 02 | 2406 | 22 | 2446 |
| 03 | 2408 | 23 | 2448 |
| 04 | 2410 | 24 | 2450 |
| 05 | 2412 | 25 | 2452 |
| 06 | 2414 | 26 | 2454 |
| 07 | 2416 | 27 | 2456 |
| 08 | 2418 | 28 | 2458 |
| 09 | 2420 | 29 | 2460 |
| 10 | 2422 | 30 | 2462 |
| 11 | 2424 | 31 | 2464 |
| 12 | 2426 | 32 | 2466 |
| 13 | 2428 | 33 | 2468 |
| 14 | 2430 | 34 | 2470 |
| 15 | 2432 | 35 | 2472 |
| 16 | 2434 | 36 | 2474 |
| 17 | 2436 | 37 | 2476 |
| 18 | 2438 | 38 | 2478 |
| 19 | 2440 | 39 | 2480 |

3. Table for Filed Antenna:

| Ant. | Brand | Model Name | Antenna Type | Connector | Gain (dBi) |
|------|-------|------------|--------------|-----------|------------|
| 1 | N/A | N/A | Dipole | N/A | 2.55 |

3.2 DESCRIPTION OF TEST MODES

To investigate the maximum EMI emission characteristics generated from EUT, the test system was pre-scanning tested based on the consideration of following EUT operation mode or test configuration mode which possibly have effect on EMI emission level. Each of these EUT operation mode(s) or test configuration mode(s) mentioned above was evaluated respectively.

| Pretest Mode | Description |
|--------------|-------------------------|
| Mode 1 | TX Mode NOTE (1) |

The EUT system operated these modes were found to be the worst case during the pre-scanning test as following:

| For Conducted Test | |
|--------------------|-------------|
| Final Test Mode | Description |
| Mode 1 | TX Mode |

| For Radiated Test | |
|-------------------|-------------------------|
| Final Test Mode | Description |
| Mode 1 | TX Mode NOTE (1) |

Note:

(1) The measurements are performed at the high, middle, low available channels.

3.3 TABLE OF PARAMETERS OF TEST SOFTWARE SETTING

During testing channel & power controlling software provided by the customer was used to control the operating channel as well as the output power level. The RF output power selection is for the setting of RF output power expected by the customer and is going to be fixed on the firmware of the final end product power parameters of BT LE

| Test Software Version | RFtest | | |
|-----------------------|--------|------|------|
| Frequency (MHz) | 2402 | 2440 | 2480 |
| BT LE | N/A | N/A | N/A |

3.4 BLOCK DIAGRAM SHOWING THE CONFIGURATION OF SYSTEM TESTED

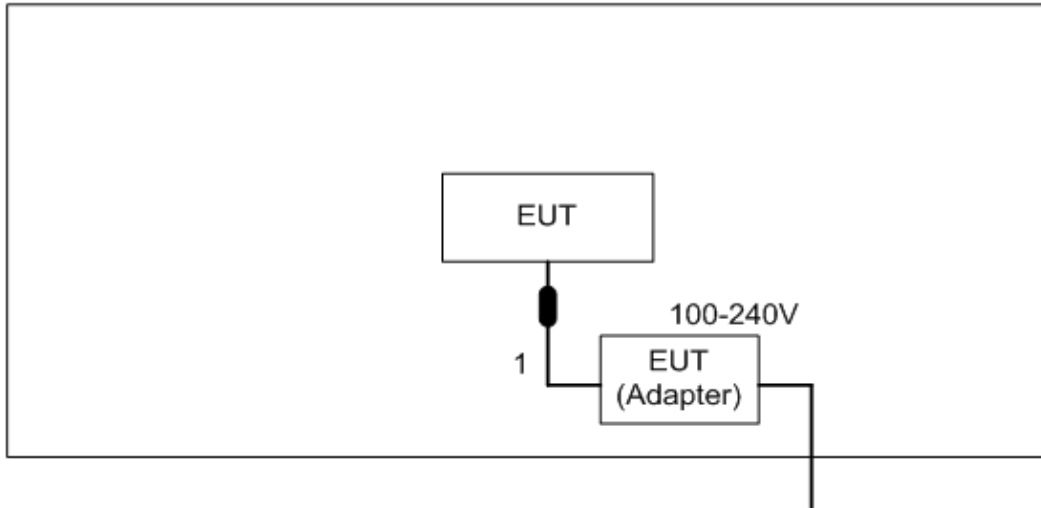

■ Ferrite core

3.5 DESCRIPTION OF SUPPORT UNITS

The EUT has been tested as an independent unit together with other necessary accessories or support units. The following support units or accessories were used to form a representative test configuration during the tests.

| Item | Equipment | Mfr/Brand | Model/Type No. | FCC ID | Series No. |
|------|-----------|-----------|----------------|--------|------------|
| - | - | - | - | - | - |

| Item | Shielded Type | Ferrite Core | Length | Note |
|------|---------------|--------------|--------|----------|
| 1 | NO | YES | 1.5 m | DC Cable |

4. EMC EMISSION TEST

4.1 CONDUCTED EMISSION MEASUREMENT

4.1.1 POWER LINE CONDUCTED EMISSION LIMITS (Frequency Range 150KHz-30MHz)

| Frequency of Emission (MHz) | Conducted Limit (dBμV) | |
|-----------------------------|------------------------|-----------|
| | Quasi-peak | Average |
| 0.15 -0□5 | 66 to 56* | 56 to 46* |
| 0.50 -5.0 | 56 | 46 |
| 5.0 -30.0 | □0 | 50 |

Note:

- (1) The limit of " * " decreases with the logarithm of the frequency
- (2) The test result calculated as following:
 Measurement Value = Reading Level + Correct Factor
 Correct Factor = Insertion Loss + Cable Loss + Attenuator Factor(if use)
 Margin Level = Measurement Value - Limit Value

The following table is the setting of the receiver

| Receiver Parameters | Setting |
|---------------------|----------|
| Attenuation | 10 dB |
| Start Frequency | 0.15 MHz |
| Stop Frequency | 30 MHz |
| IF Bandwidth | 9 kHz |

4.1.2 TEST PROCEDURE

- a. The EUT was placed 0.8 meters from the horizontal ground plane with EUT being connected to the power mains through a line impedance stabilization network (LISN). All other support equipments powered from additional LISN(s). The LISN provide 50 Ohm/ 50uH of coupling impedance for the measuring instrument.
- b. Interconnecting cables that hang closer than 40 cm to the ground plane shall be folded back and forth in the center forming a bundle 30 to 40 cm long.
- c. I/O cables that are not connected to a peripheral shall be bundled in the center. The end of the cable may be terminated, if required, using the correct terminating impedance. The overall length shall not exceed 1 m.
- d. LISN at least 80 cm from nearest part of EUT chassis.
- e. For the actual test configuration, please refer to the related Item –EUT Test Photos.

4.1.3 DEVIATION FROM TEST STANDARD

No deviation

4.1.4 TEST SETUP

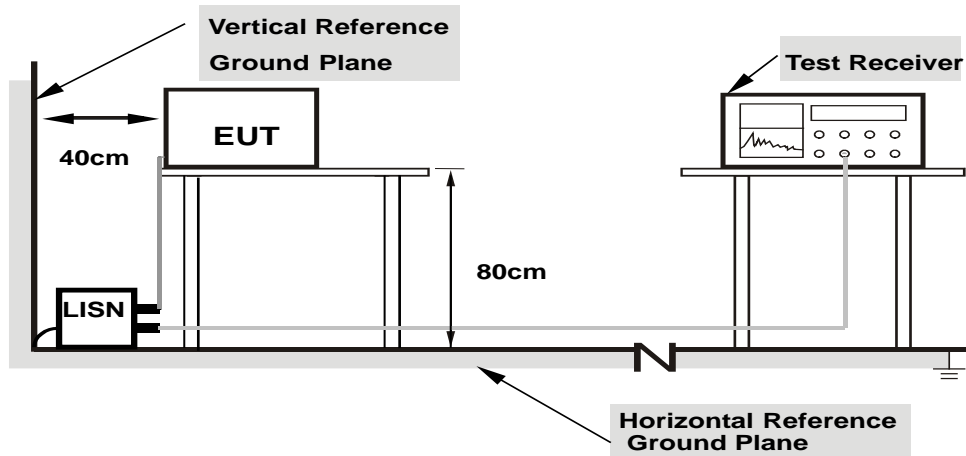

- Note:**
- 1.Support units were connected to second LISN.
 - 2.Both of LISNs (AMN) are 80 cm from EUT and at least 80 from other units and other metal planes

4.1.5 EUT OPERATING CONDITIONS

The EUT was configured for testing in a typical fashion (as a customer would normally use it). The EUT has been programmed to continuously transmit during test. This operating condition was tested and used to collect the included data.

4.1.6 EUT TEST CONDITIONS

Temperature: 24°C Relative Humidity: 60% Test Voltage: AC 120V/60Hz

4.1.7 TEST RESULTS

Please refer to the Attachment A.

Remark:

- (1) All readings are QP Mode value unless otherwise stated AVG in column of『Note』. If the QP Mode Measured value compliance with the QP Limits and lower than AVG Limits, the EUT shall be deemed to meet both QP & AVG Limits and then only QP Mode was measured, but AVG Mode didn't perform.In this case, a “ * ” marked in AVG Mode column of Interference Voltage Measured.
- (2) Measuring frequency range from 150KHz to 30MHz.
- (3) “ N/A” denotes test is not applicable to this device.

4.2 RADIATED EMISSION MEASUREMENT

4.2.1 RADIATED EMISSION LIMITS

In case the emission fall within the restricted band specified on 15.205(a), then the 15.209(a) limit in the table below has to be followed.

LIMITS OF RADIATED EMISSION MEASUREMENT (9KHz-1000MHz)

| Frequency (MHz) | Field Strength (microvolts/meter) | Measurement Distance (meters) |
|-----------------|-----------------------------------|-------------------------------|
| 0.009~0.490 | 2400/F(KHz) | 300 |
| 0.490~1.705 | 24000/F(KHz) | 30 |
| 1.705~30.0 | 30 | 30 |
| 30~88 | 100 | 3 |
| 88~216 | 150 | 3 |
| 216~960 | 200 | 3 |
| 960~1000 | 500 | 3 |

LIMITS OF RADIATED EMISSION MEASUREMENT (Above 1000MHz)

| Frequency (MHz) | (dBuV/m) (at 3 meters) | |
|-----------------|------------------------|---------|
| | PEAK | AVERAGE |
| Above 1000 | 74 | 54 |

Notes:

- (1) The limit for radiated test was performed according to FCC PART 15C.
- (2) The tighter limit applies at the band edges.
- (3) Emission level (dBuV/m)=20log Emission level (uV/m).
- (4) The test result calculated as following:
 Measurement Value = Reading Level + Correct Factor
 Correct Factor = Antenna Factor + Cable Loss - Amplifier Gain(if use)
 Margin Level = Measurement Value - Limit Value

| Spectrum Parameter | Setting |
|--|---|
| Attenuation | Auto |
| Start Frequency | 1000 MHz |
| Stop Frequency | 10th carrier harmonic |
| RBW / VBW (Emission in restricted band) | RBW 1MHz VBW 3MHz peak detector for Pk value RMS detector for AV value |

| Receiver Parameter | Setting |
|------------------------|-----------------------------------|
| Attenuation | Auto |
| Start ~ Stop Frequency | 9KHz~90KHz for PK/AVG detector |
| Start ~ Stop Frequency | 90KHz~110KHz for QP detector |
| Start ~ Stop Frequency | 110KHz~490KHz for PK/AVG detector |
| Start ~ Stop Frequency | 490KHz~30MHz for QP detector |
| Start ~ Stop Frequency | 30MHz~1000MHz for QP detector |

4.2.2 TEST PROCEDURE

- a. The measuring distance of 3 m shall be used for measurements. The EUT was placed on the top of a rotating table 0.8 meter above the ground at a 3 meter semi-anechoic chamber. The table was rotated 360 degrees to determine the position of the highest radiation.(below 1GHz)
- b. The measuring distance of 3 m shall be used for measurements. The EUT was placed on the top of a rotating table 1.5 meter above the ground at a 3 meter semi-anechoic chamber. The table was rotated 360 degrees to determine the position of the highest radiation.(above 1GHz)
- c. The height of the equipment or of the substitution antenna shall be 0.8m or 1.5m; the height of the test antenna shall vary between 1 m to 4 m. Both horizontal and vertical polarizations of the antenna are set to make the measurement.
- d. For each suspected emission, the EUT was arranged to its worst case and then the antenna was tuned to heights find the maximum reading (used Bore sight function).
- e. The receiver system was set to peak and average detect function and specified bandwidth with maximum hold mode when the test frequency is above 1GHz.
- f. The initial step in collecting radiated emission data is a receiver peak detector mode pre-scanning the measurement frequency range. Significant peaks are then marked and then Quasi Peak detector mode re-measured.
- g. All readings are Peak unless otherwise stated QP in column of Note. Peak denotes that the Peak reading compliance with the QP Limits and then QP Mode measurement didn't perform. (below 1GHz)
- h. All readings are Peak Mode value unless otherwise stated AVG in column of Note. If the Peak Mode Measured value compliance with the Peak Limits and lower than AVG Limits, the EUT shall be deemed to meet both Peak & AVG Limits and then only Peak Mode was measured, but AVG Mode didn't perform. (above 1GHz)
- i. For the actual test configuration, please refer to the related Item –EUT Test Photos.

4.2.3 DEVIATION FROM TEST STANDARD

No deviation

4.2.4 TEST SETUP

(A) Radiated Emission Test Set-Up Frequency Below 1 GHz

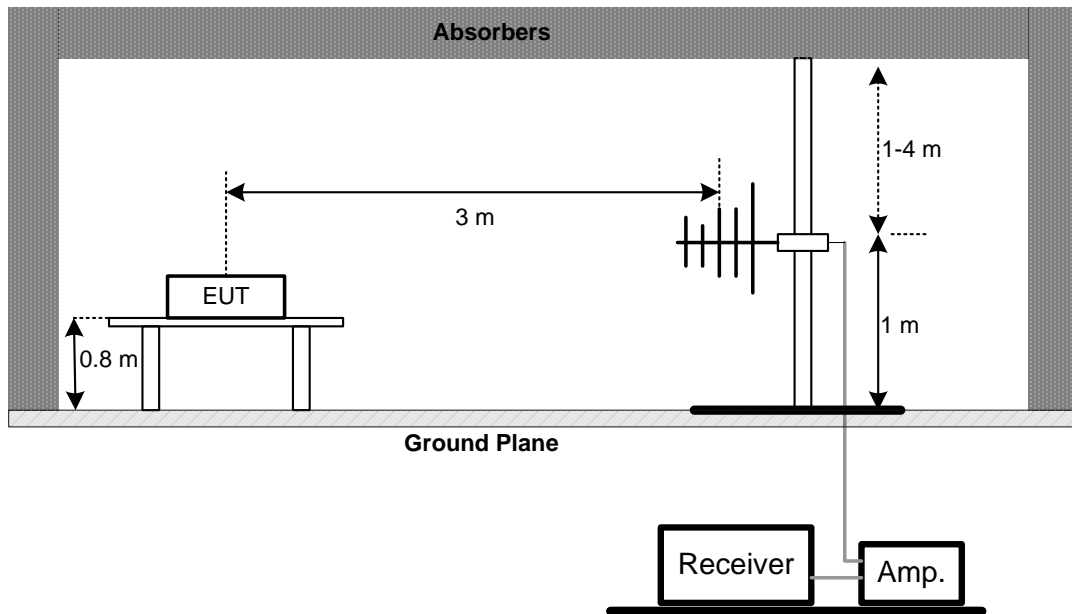

(B) Radiated Emission Test Set-Up Frequency Above 1 GHz

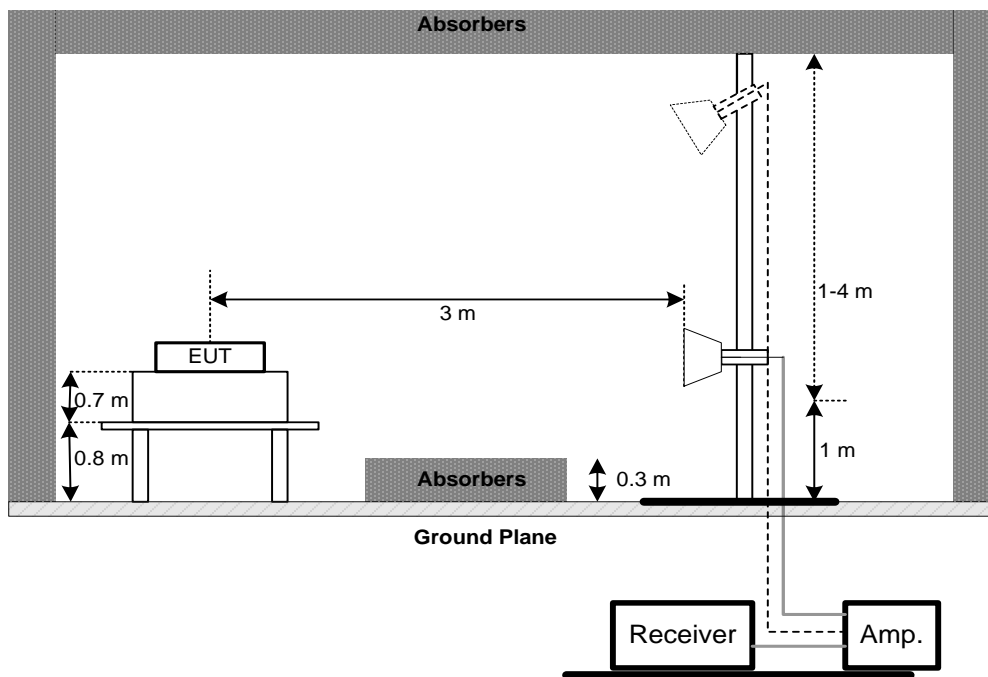

(C) For radiated emissions below 30MHz

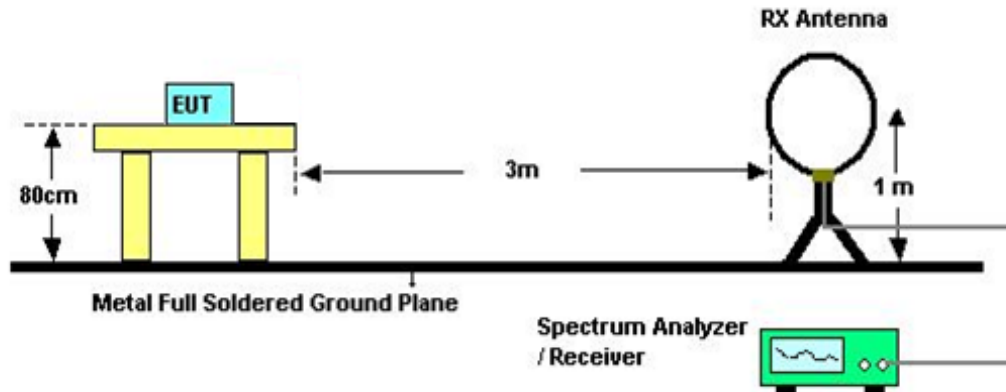

4.2.5 EUT OPERATING CONDITIONS

The EUT was programmed to be in continuously transmitting mode.

4.2.6 EUT TEST CONDITIONS

Temperature: 22°C Relative Humidity: 56% Test Voltage: AC 120V/60Hz

4.2.7 TEST RESULTS (9KHZ TO 30MHZ)

Please refer to the Attachment B

Remark:

- (1) The amplitude of spurious emissions which are attenuated by more than 20 dB below the permissible value has no need to be reported.
- (2) Distance extrapolation factor = $40 \log(\text{specific distance} / \text{test distance})$ (dB).
- (3) Limit line = specific limits (dBuV) + distance extrapolation factor.

4.2.8 TEST RESULTS (30MHZ TO 1000 MHZ)

Please refer to the Attachment C.

4.2.9 TEST RESULTS (ABOVE 1000 MHZ)

Please refer to the Attachment D.

Remark:

- (1) No limit: This is fundamental signal, the judgment is not applicable.
For fundamental signal judgment was referred to Peak output test.

5. BANDWIDTH TEST

5.1 APPLIED PROCEDURES / LIMIT

| FCC Part15 (15.247) , Subpart C | | | | |
|---------------------------------|-----------|---|-----------------------|--------|
| Section | Test Item | Limit | Frequency Range (MHz) | Result |
| 15.247(a)(2) | Bandwidth | $\geq 500\text{KHz}$ (6dB bandwidth) | 2400-2483.5 | PASS |

5.1.1 TEST PROCEDURE

- a. The EUT was directly connected to the spectrum analyzer and antenna output port as show in the block diagram below,
- b. Spectrum Setting : RBW= 100KHz, VBW=300KHz, Sweep time = 2.5 ms.

5.1.2 DEVIATION FROM STANDARD

No deviation.

5.1.3 TEST SETUP

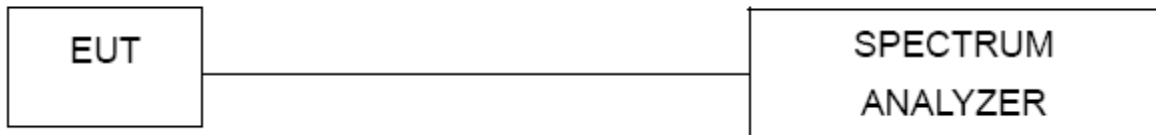

5.1.4 EUT OPERATION CONDITIONS

The EUT tested system was configured as the statements of 4.1.5 unless otherwise a special operating condition is specified in the follows during the testing.

5.1.5 EUT TEST CONDITIONS

Temperature: 24°C Relative Humidity: 60% Test Voltage: AC 120V/60Hz

5.1.6 TEST RESULTS

Please refer to the Attachment E.

6. MAXIMUM OUTPUT POWER TEST

6.1 APPLIED PROCEDURES / LIMIT

| FCC Part15 (15.247) , Subpart C | | | | |
|---------------------------------|----------------------|-----------------|-----------------------|--------|
| Section | Test Item | Limit | Frequency Range (MHz) | Result |
| 15.247(b)(3) | Maximum Output Power | 1 watt or 30dBm | 2400-2483.5 | PASS |

6.1.1 TEST PROCEDURE

- a. The EUT was directly connected to the power meter and antenna output port as show in the block diagram below,
- b. The maximum peak conducted output power was performed in accordance with method 9.1.2 of FCC KDB 558074 D01 DTS Meas Guidance.

6.1.2 DEVIATION FROM STANDARD

No deviation.

6.1.3 TEST SETUP

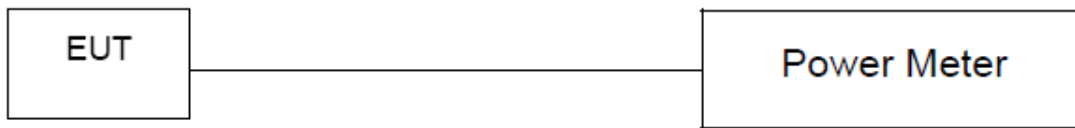

6.1.4 EUT OPERATION CONDITIONS

The EUT tested system was configured as the statements of 4.1.5 unless otherwise a special operating condition is specified in the follows during the testing.

6.1.5 EUT TEST CONDITIONS

Temperature: 24°C Relative Humidity: 60% Test Voltage: AC 120V/60Hz

6.1.6 TEST RESULTS

Please refer to the Attachment F.

7. ANTENNA CONDUCTED SPURIOUS EMISSION

7.1 APPLIED PROCEDURES / LIMIT

In any 100 kHz bandwidth outside the frequency band in which the spread spectrum or digitally modulated device is operating, the RF power that is produced shall be at least 20 dB below that in the 100 kHz bandwidth within the band that contains the highest level of the desired power, based on either an RF conducted or a radiated measurement, provided that the transmitter demonstrates compliance with the peak conducted power limits.

7.1.1 TEST PROCEDURE

- a. The EUT was directly connected to the spectrum analyzer and antenna output port as show in the block diagram below,
- b. Spectrum Setting : RBW= 100KHz, VBW=300KHz, Sweep time = 10 ms.
- c. Offset=antenna gain+cable loss

7.1.2 DEVIATION FROM STANDARD

No deviation.

7.1.3 TEST SETUP



7.1.4 EUT OPERATION CONDITIONS

The EUT tested system was configured as the statements of 4.1.5 unless otherwise a special operating condition is specified in the follows during the testing.

7.1.5 EUT OPERATION CONDITIONS

Temperature: 24°C Relative Humidity: 60% Test Voltage: AC 120V/60Hz

7.1.6 TEST RESULTS

Please refer to the Attachment G.

8. POWER SPECTRAL DENSITY TEST

8.1 APPLIED PROCEDURES / LIMIT

| FCC Part15 (15.247) , Subpart C | | | | |
|---------------------------------|------------------------|---------------------|-----------------------|--------|
| Section | Test Item | Limit | Frequency Range (MHz) | Result |
| 15.247(e) | Power Spectral Density | 8 dBm (in any 3KHz) | 2400-2483.5 | PASS |

8.1.1 TEST PROCEDURE

- a. The EUT was directly connected to the spectrum analyzer and antenna output port as show in the block diagram below,
- b. Spectrum Setting: RBW=3KHz, VBW=10 KHz, Sweep time = auto.

8.1.2 DEVIATION FROM STANDARD

No deviation.

8.1.3 TEST SETUP



8.1.4 EUT OPERATION CONDITIONS

The EUT tested system was configured as the statements of 4.1.5 unless otherwise a special operating condition is specified in the follows during the testing.

8.1.5 EUT TEST CONDITIONS

Temperature: 24°C Relative Humidity: 60% Test Voltage: AC 120V/60Hz

8.1.6 TEST RESULTS

Please refer to the Attachment H.

9. MEASUREMENT INSTRUMENTS LIST

| Conducted Emission Measurement | | | | | |
|--------------------------------|----------------------|--------------|--------------------------|------------|------------------|
| Item | Kind of Equipment | Manufacturer | Type No. | Serial No. | Calibrated until |
| 1 | LISN | EMCO | 3816/2 | 0052765 | Mar. 27, 2017 |
| 2 | LISN | R&S | ENV216 | 101447 | Mar. 27, 2017 |
| 3 | Test Cable | emci | RG223(9KHz-30M Hz) | C_17 | Mar. 10, 2017 |
| 4 | EMI Test Receiver | R&S | ESCI | 100382 | Mar. 27, 2017 |
| 5 | 50Ω Terminator | SHX | TF2-3G-A | 08122901 | Mar. 27, 2017 |
| 6 | Measurement Software | Farad | EZ-EMC Ver.NB-03A1-01 | N/A | N/A |

| Radiated Emission Measurement | | | | | |
|-------------------------------|-------------------------------------|----------------|--------------------------------------|---------------|------------------|
| Item | Kind of Equipment | Manufacturer | Type No. | Serial No. | Calibrated until |
| 1 | Antenna | Schwarzbeck | VULB9160 | 9160-3232 | Mar. 27, 2017 |
| 2 | Amplifier | HP | 8447D | 2944A09673 | Nov. 09, 2016 |
| 3 | Receiver | AGILENT | N9038A | MY52130039 | Oct. 11, 2016 |
| 4 | Test Cable | emci | LMR-400(30MHz-1GHz) | C-01 | Jun. 26, 2017 |
| 5 | Control | CT | SC100 | N/A | N/A |
| 6 | Position Control | MF | MF-7802 | MF780208416 | N/A |
| 7 | Antenna | ETS | 3115 | 00075789 | Mar. 27, 2017 |
| 8 | Amplifier | Agilent | 8449B | 3008A02274 | Nov. 01, 2016 |
| 9 | Receiver | AGILENT | N9038A | MY52130039 | Oct. 11, 2016 |
| 10 | Test Cable | emci | EMC104-SM-S M-10000(1GHz-26.5GHz) | C-68 | Jun. 26, 2017 |
| 11 | Controller | CT | SC100 | N/A | N/A |
| 12 | Broad-Band Horn Antenna | Schwarzbeck | BBHA 9170 | 9170319 | Apr. 23, 2017 |
| 13 | Microwave Preamplifier With Adaptor | EMC INSTRUMENT | EMC2654045 | 980039 & HA01 | Mar. 27, 2017 |
| 14 | Active Loop Antenna | R&S | HFH2-Z2 | 830749/020 | Sep. 06, 2017 |
| 15 | Measurement Software | Farad | EZ-EMC Ver.NB-03A1-01 | N/A | N/A |

| 6dB Bandwidth Measurement | | | | | |
|---------------------------|-------------------|--------------|----------|------------|------------------|
| Item | Kind of Equipment | Manufacturer | Type No. | Serial No. | Calibrated until |
| 1 | Spectrum Analyzer | R&S | FSP 40 | 100185 | Oct. 11, 2016 |

| Peak Output Power Measurement | | | | | |
|-------------------------------|--------------------|--------------|----------|------------|------------------|
| Item | Kind of Equipment | Manufacturer | Type No. | Serial No. | Calibrated until |
| 1 | Power Meter | ANRITSU | ML2495A | 1128009 | Mar. 27, 2017 |
| 2 | Pulse Power Sensor | ANRITSU | MA 2411B | 1027500 | Mar. 27, 2017 |

| Antenna Conducted Spurious Emission Measurement | | | | | |
|---|-------------------|--------------|----------|------------|------------------|
| Item | Kind of Equipment | Manufacturer | Type No. | Serial No. | Calibrated until |
| 1 | Spectrum Analyzer | R&S | FSP 40 | 100185 | Oct. 11, 2016 |

| Power Spectral Density Measurement | | | | | |
|------------------------------------|-------------------|--------------|----------|------------|------------------|
| Item | Kind of Equipment | Manufacturer | Type No. | Serial No. | Calibrated until |
| 1 | Spectrum Analyzer | R&S | FSP 40 | 100185 | Oct. 11, 2016 |

Remark: "N/A" denotes no model name, serial no. or calibration specified.
 All calibration period of equipment list is one year.

ATTACHMENT A - CONDUCTED EMISSION

Test Mode: TX Mode

Line

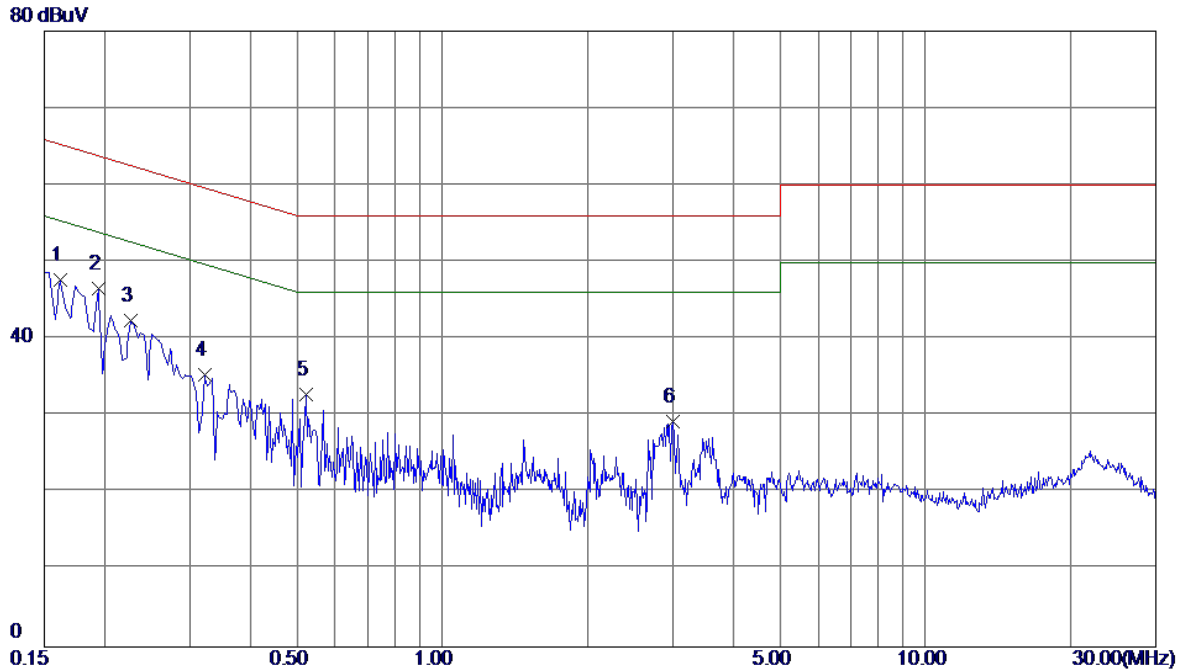

| No. | Freq. MHz | Reading Level dBuV | Correct Factor dB | Measure ment dBuV | Limit dBuV | Margin dB | Detector | Comment |
|-----|--------------|--------------------------|-------------------------|-------------------------|---------------|--------------|----------|---------|
| 1 | 0.1620 | 38.09 | 9.57 | 47.66 | 65.36 | -17.70 | Peak | |
| 2 * | 0.1940 | 36.95 | 9.57 | 46.52 | 63.86 | -17.34 | Peak | |
| 3 | 0.2260 | 32.80 | 9.57 | 42.37 | 62.60 | -20.23 | Peak | |
| 4 | 0.3220 | 25.74 | 9.58 | 35.32 | 59.66 | -24.34 | Peak | |
| 5 | 0.5220 | 23.14 | 9.69 | 32.83 | 56.00 | -23.17 | Peak | |
| 6 | 3.0059 | 19.09 | 10.26 | 29.35 | 56.00 | -26.65 | Peak | |

Test Mode: TX Mode

Neutral

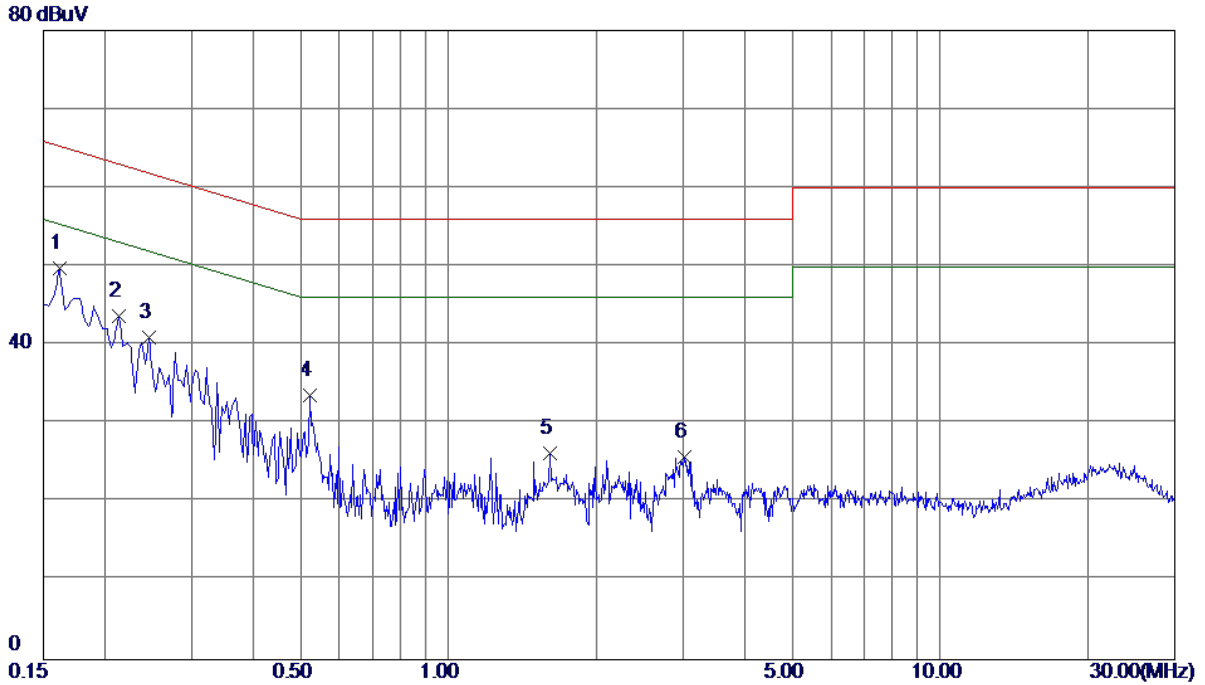

| No. | Freq. MHz | Reading Level dBuV | Correct Factor dB | Measure ment dBuV | Limit dBuV | Margin dB | Detector | Comment |
|-----|--------------|--------------------------|-------------------------|-------------------------|---------------|--------------|----------|---------|
| 1 * | 0.1620 | 40.22 | 9.51 | 49.73 | 65.36 | -15.63 | Peak | |
| 2 | 0.2140 | 34.09 | 9.57 | 43.66 | 63.05 | -19.39 | Peak | |
| 3 | 0.2460 | 31.34 | 9.57 | 40.91 | 61.89 | -20.98 | Peak | |
| 4 | 0.5220 | 24.06 | 9.49 | 33.55 | 56.00 | -22.45 | Peak | |
| 5 | 1.6060 | 16.48 | 9.78 | 26.26 | 56.00 | -29.74 | Peak | |
| 6 | 3.0180 | 15.78 | 9.96 | 25.74 | 56.00 | -30.26 | Peak | |

ATTACHMENT B - RADIATED EMISSION (9KHZ TO 30MHZ)

Test Mode: TX Mode

Ant 0°

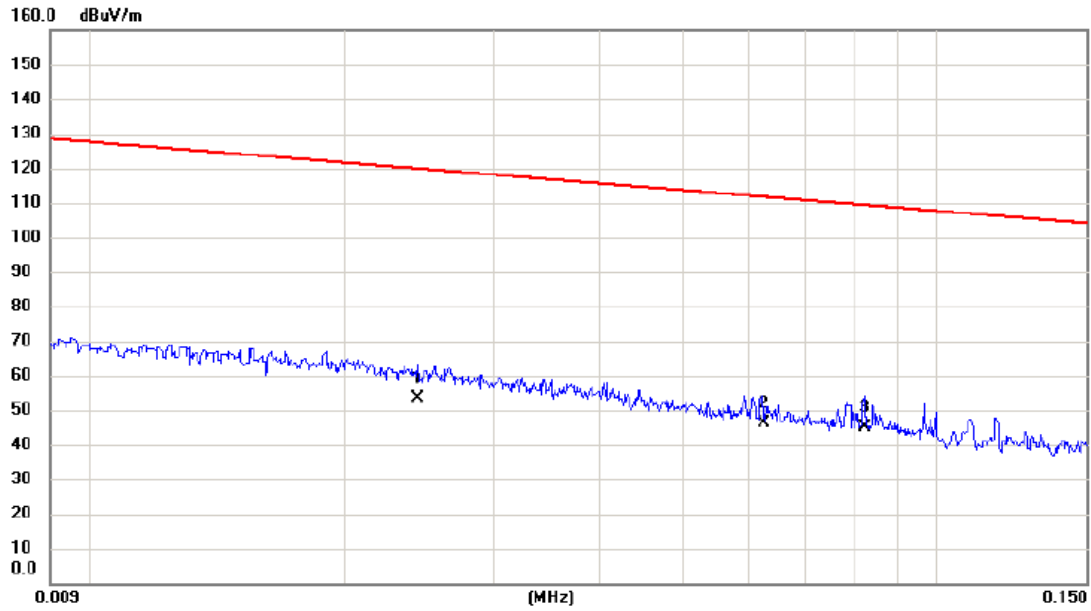

| No. | Mk. | Freq. MHz | Reading Level dBuV | Correct Factor dB | Measure- ment dBuV/m | Limit dBuV/m | Margin dB | Detector | Comment |
|-----|-----|--------------|--------------------------|-------------------------|----------------------------|-----------------|--------------|----------|---------|
| 1 | | 0.0244 | 30.33 | 22.98 | 53.31 | 119.86 | -66.55 | AVG | |
| 2 | | 0.0624 | 26.44 | 19.68 | 46.12 | 111.70 | -65.58 | AVG | |
| 3 | * | 0.0820 | 25.83 | 19.22 | 45.05 | 109.33 | -64.28 | AVG | |

Test Mode: TX Mode

Ant 0°

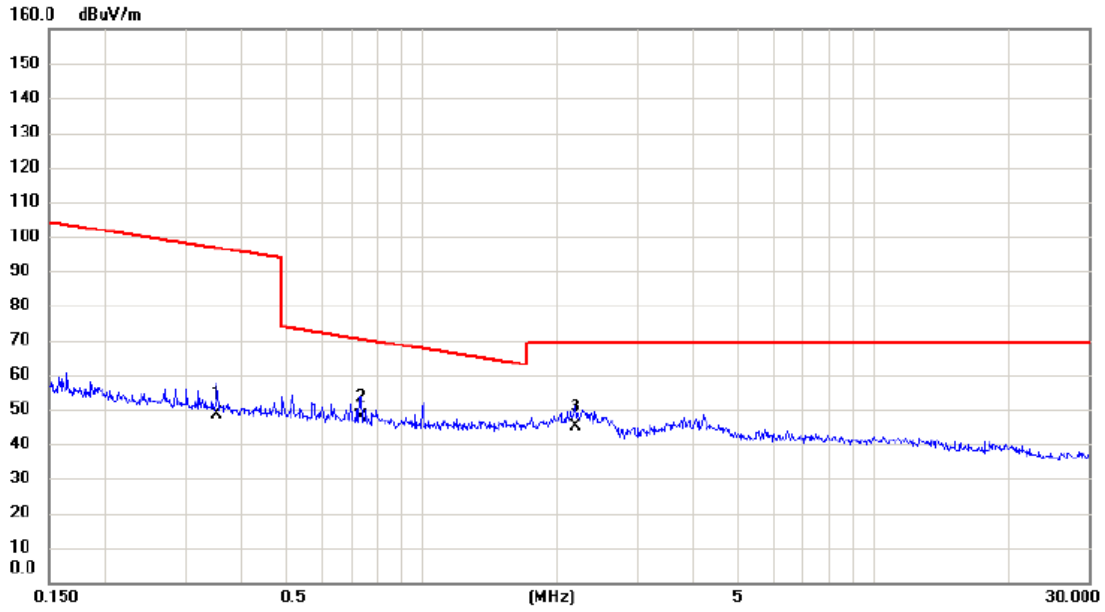

| No. | Mk. | Freq. MHz | Reading Level dBuV | Correct Factor dB | Measure- ment dBuV/m | Limit dBuV/m | Margin dB | Detector | Comment |
|-----|-----|--------------|--------------------------|-------------------------|----------------------------|-----------------|--------------|----------|---------|
| 1 | | 0.3520 | 29.96 | 18.54 | 48.50 | 96.67 | -48.17 | AVG | |
| 2 | * | 0.7313 | 29.47 | 18.46 | 47.93 | 70.32 | -22.39 | QP | |
| 3 | | 2.1898 | 27.45 | 17.66 | 45.11 | 69.54 | -24.43 | QP | |

Test Mode: TX Mode

Ant 90°

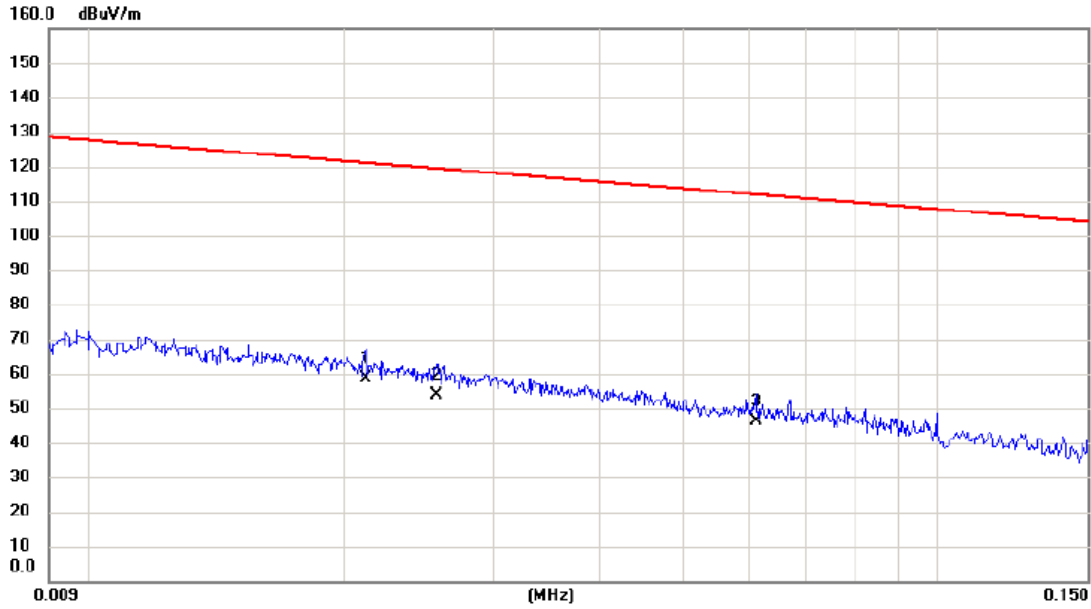

| No. | Mk. | Freq. | Reading Level | Correct Factor | Measurement | Limit | Margin | Detector | Comment |
|-----|-----|--------|---------------|----------------|-------------|--------|--------|----------|---------|
| | | MHz | dBuV | dB | dBuV/m | dBuV/m | dB | | |
| 1 | * | 0.0212 | 35.43 | 23.37 | 58.80 | 121.08 | -62.28 | AVG | |
| 2 | | 0.0257 | 30.91 | 22.82 | 53.73 | 119.41 | -65.68 | AVG | |
| 3 | | 0.0610 | 26.36 | 19.70 | 46.06 | 111.90 | -65.84 | AVG | |

Test Mode: TX Mode

Ant 90°

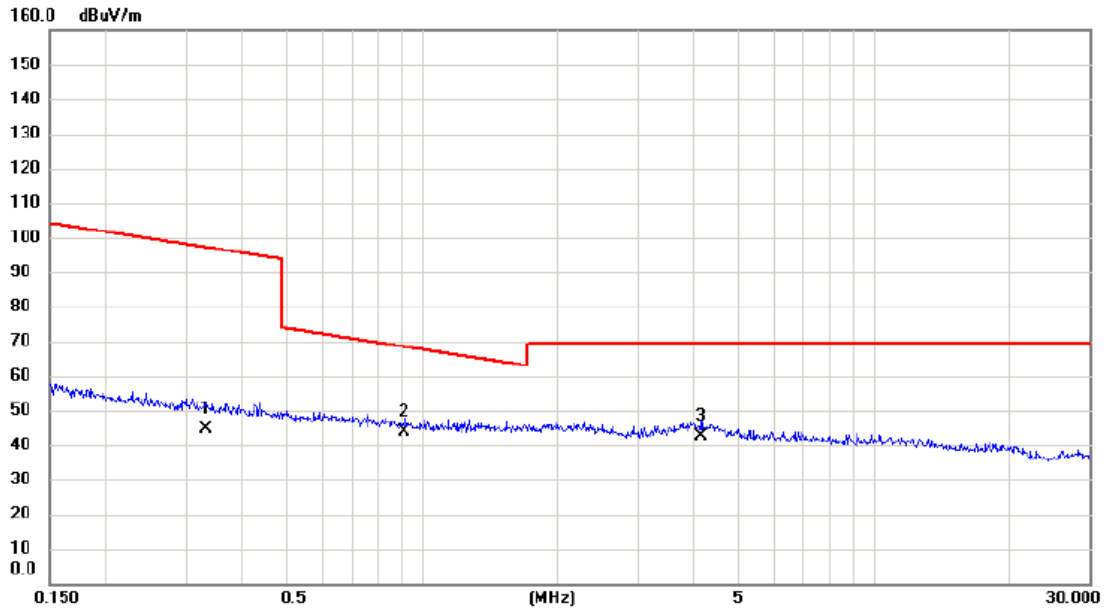

| No. | Mk. | Freq. MHz | Reading Level dBuV | Correct Factor dB | Measure- ment dBuV/m | Limit dBuV/m | Margin dB | Detector | Comment |
|-----|-----|--------------|--------------------------|-------------------------|----------------------------|-----------------|--------------|----------|---------|
| 1 | | 0.3321 | 26.23 | 18.56 | 44.79 | 97.18 | -52.39 | AVG | |
| 2 | * | 0.9136 | 25.87 | 17.96 | 43.83 | 68.39 | -24.56 | QP | |
| 3 | | 4.1356 | 24.06 | 18.48 | 42.54 | 69.54 | -27.00 | QP | |

ATTACHMENT C - RADIATED EMISSION (30MHZ TO 1000MHZ)

Test Mode: TX 2402MHz _CH00_1Mbps

Vertical

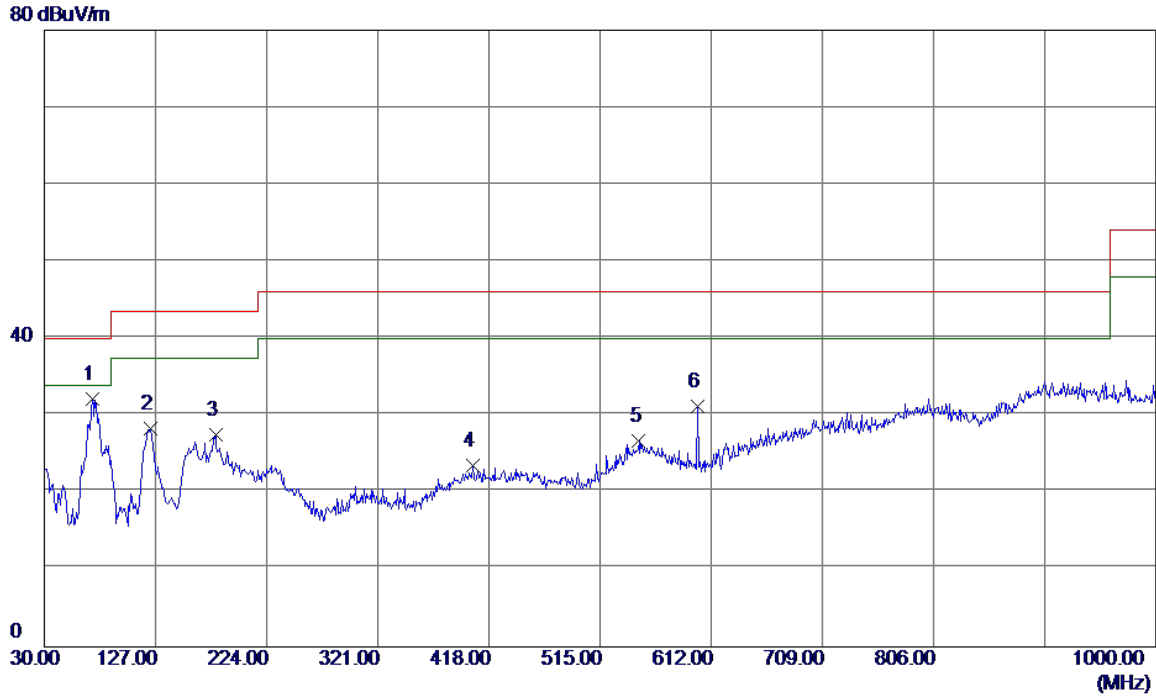

| No. | Freq. MHz | Reading Level dBuV/m | Correct Factor dB | Measure ment dBuV/m | Limit dBuV/m | Margin dB | Detector | Comment |
|-----|--------------|----------------------------|-------------------------|---------------------------|-----------------|--------------|----------|---------|
| 1 * | 71.7100 | 48.66 | -16.55 | 32.11 | 40.00 | -7.89 | Peak | |
| 2 | 123.1200 | 41.46 | -13.11 | 28.35 | 43.50 | -15.15 | Peak | |
| 3 | 179.3800 | 40.30 | -12.80 | 27.50 | 43.50 | -16.00 | Peak | |
| 4 | 404.4200 | 31.36 | -7.80 | 23.56 | 46.00 | -22.44 | Peak | |
| 5 | 548.9500 | 31.33 | -4.65 | 26.68 | 46.00 | -19.32 | Peak | |
| 6 | 600.3600 | 38.30 | -7.04 | 31.26 | 46.00 | -14.74 | Peak | |

Test Mode: TX 2402MHz _CH00_1Mbps

Horizontal

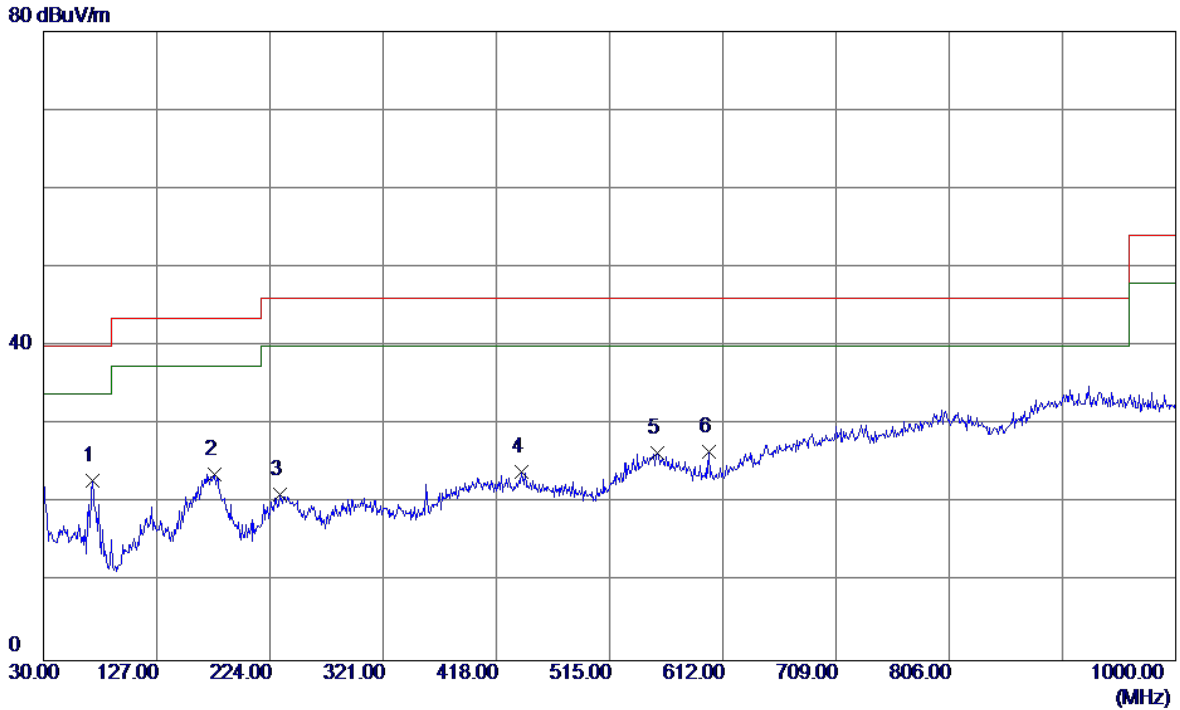

| No. | Freq. MHz | Reading Level dBuV/m | Correct Factor dB | Measure ment dBuV/m | Limit dBuV/m | Margin dB | Detector | Comment |
|-----|--------------|----------------------------|-------------------------|---------------------------|-----------------|--------------|----------|---------|
| 1 * | 71.7100 | 39.47 | -16.55 | 22.92 | 40.00 | -17.08 | Peak | |
| 2 | 176.4700 | 36.35 | -12.63 | 23.72 | 43.50 | -19.78 | Peak | |
| 3 | 232.7300 | 34.61 | -13.48 | 21.13 | 46.00 | -24.87 | Peak | |
| 4 | 439.3400 | 31.99 | -7.95 | 24.04 | 46.00 | -21.96 | Peak | |
| 5 | 555.7400 | 31.16 | -4.83 | 26.33 | 46.00 | -19.67 | Peak | |
| 6 | 600.3600 | 33.57 | -7.04 | 26.53 | 46.00 | -19.47 | Peak | |

Test Mode: TX 2440MHz _CH19_1Mbps

Vertical

80 dBuV/m

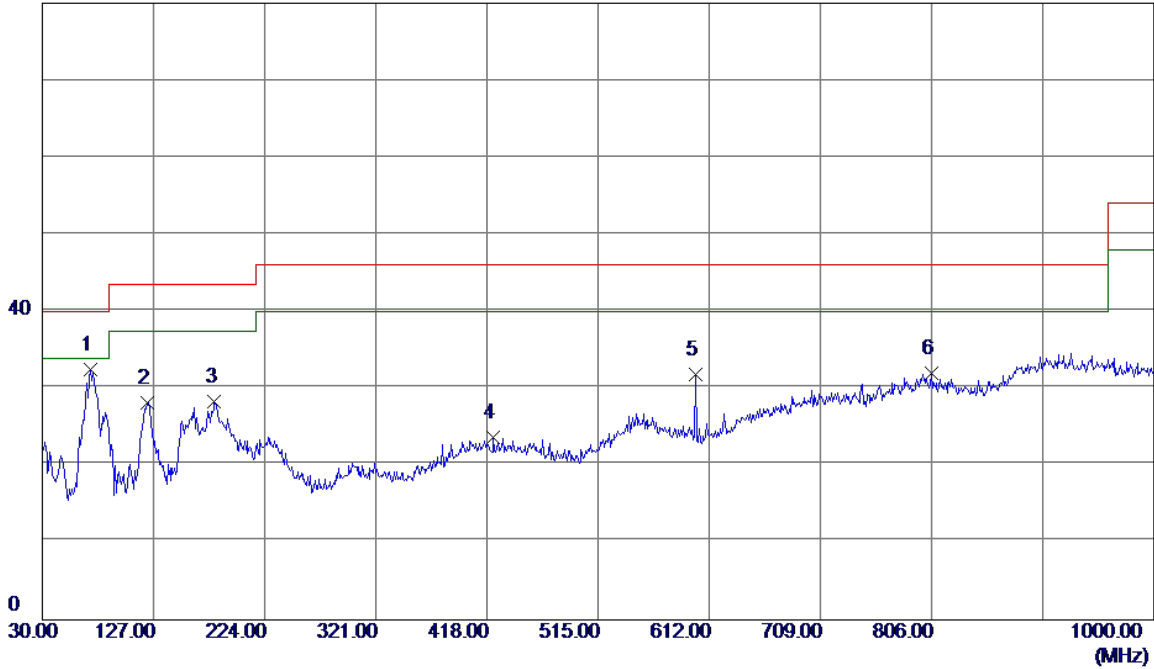

| No. | Freq. MHz | Reading Level dBuV/m | Correct Factor dB | Measure ment dBuV/m | Limit dBuV/m | Margin dB | Detector | Comment |
|-----|--------------|----------------------------|-------------------------|---------------------------|-----------------|--------------|----------|---------|
| 1 * | 71.7100 | 48.99 | -16.55 | 32.44 | 40.00 | -7.56 | Peak | |
| 2 | 121.1800 | 41.50 | -13.33 | 28.17 | 43.50 | -15.33 | Peak | |
| 3 | 180.3500 | 41.13 | -12.88 | 28.25 | 43.50 | -15.25 | Peak | |
| 4 | 423.8200 | 31.49 | -7.88 | 23.61 | 46.00 | -22.39 | Peak | |
| 5 | 600.3600 | 38.84 | -7.04 | 31.80 | 46.00 | -14.20 | Peak | |
| 6 | 806.0000 | 31.92 | 0.08 | 32.00 | 46.00 | -14.00 | Peak | |

Test Mode: TX 2440MHz _CH19_1Mbps

Horizontal

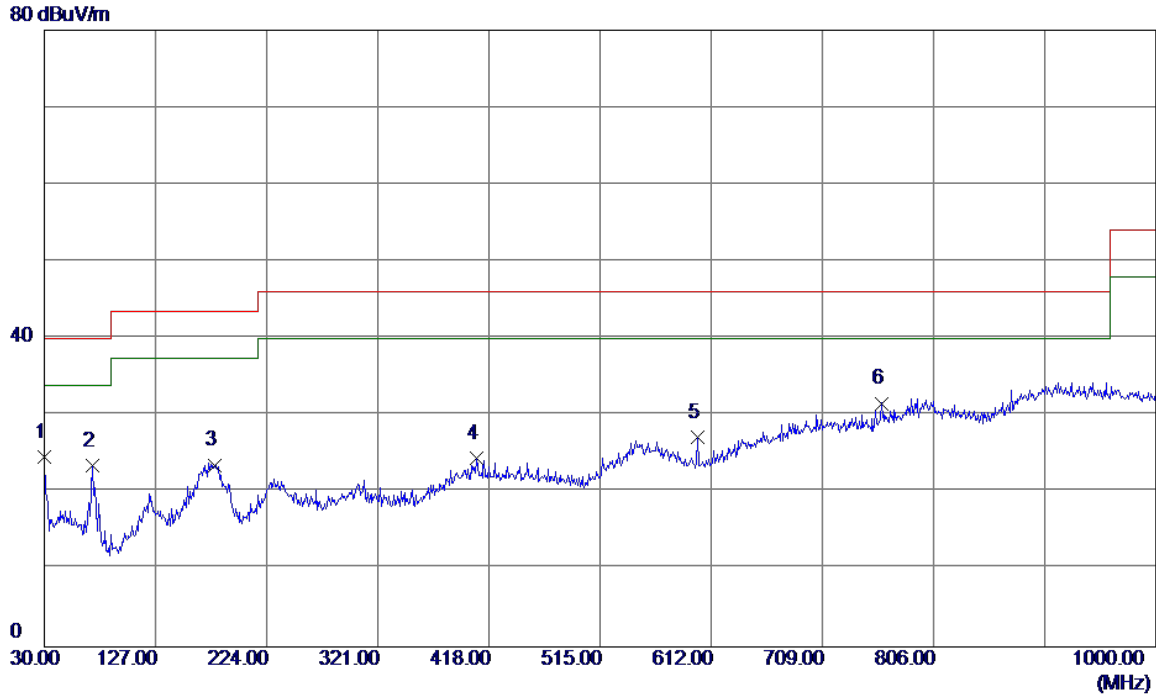

| No. | Freq. MHz | Reading Level dBuV/m | Correct Factor dB | Measure ment dBuV/m | Limit dBuV/m | Margin dB | Detector | Comment |
|-----|--------------|----------------------------|-------------------------|---------------------------|-----------------|--------------|----------|---------|
| 1 | 30.0000 | 38.61 | -14.03 | 24.58 | 40.00 | -15.42 | Peak | |
| 2 | 71.7100 | 40.03 | -16.55 | 23.48 | 40.00 | -16.52 | Peak | |
| 3 | 178.4100 | 36.34 | -12.74 | 23.60 | 43.50 | -19.90 | Peak | |
| 4 | 407.3299 | 32.33 | -7.81 | 24.52 | 46.00 | -21.48 | Peak | |
| 5 | 600.3600 | 34.24 | -7.04 | 27.20 | 46.00 | -18.80 | Peak | |
| 6 * | 760.4099 | 33.11 | -1.51 | 31.60 | 46.00 | -14.40 | Peak | |

Test Mode: TX 2480MHz _CH39_1Mbps

Vertical

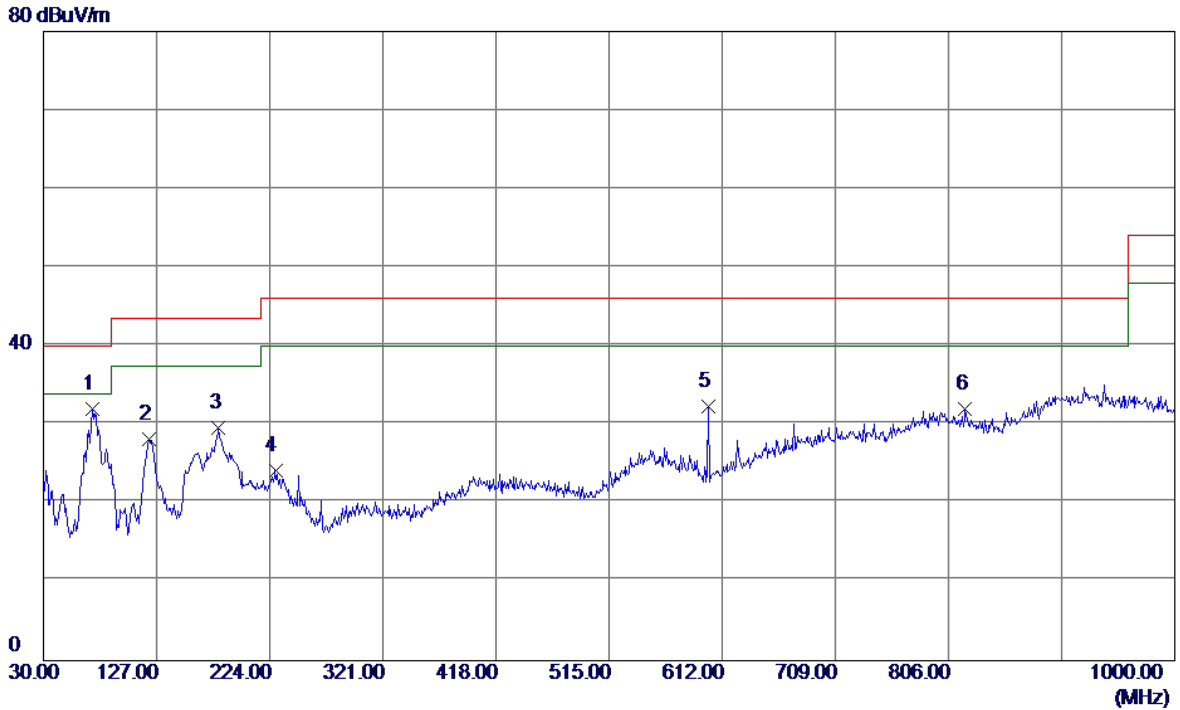

| No. | Freq. MHz | Reading Level dBuV/m | Correct Factor dB | Measure ment dBuV/m | Limit dBuV/m | Margin dB | Detector | Comment |
|-----|--------------|----------------------------|-------------------------|---------------------------|-----------------|--------------|----------|---------|
| 1 * | 71.7100 | 48.59 | -16.55 | 32.04 | 40.00 | -7.96 | Peak | |
| 2 | 120.2100 | 41.57 | -13.43 | 28.14 | 43.50 | -15.36 | Peak | |
| 3 | 180.3500 | 42.50 | -12.88 | 29.62 | 43.50 | -13.88 | Peak | |
| 4 | 228.8500 | 37.59 | -13.47 | 24.12 | 46.00 | -21.88 | Peak | |
| 5 | 600.3600 | 39.32 | -7.04 | 32.28 | 46.00 | -13.72 | Peak | |
| 6 | 820.5500 | 32.36 | -0.36 | 32.00 | 46.00 | -14.00 | Peak | |

Test Mode: TX 2480MHz _CH39_1Mbps

Horizontal

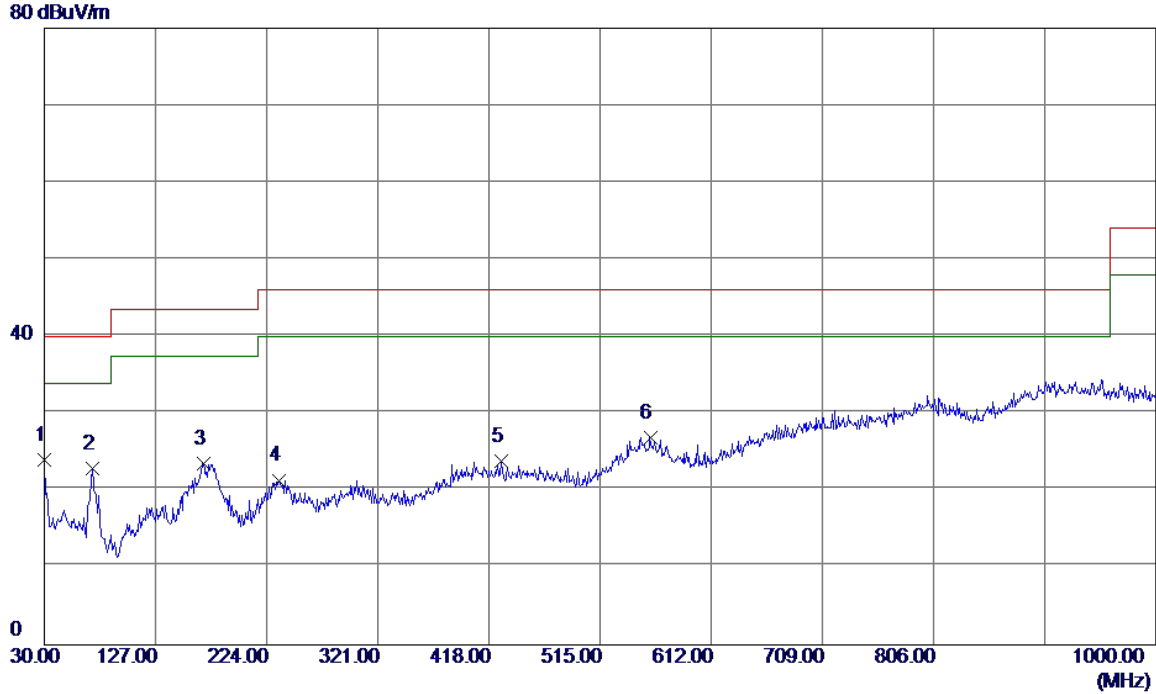

| No. | Freq. MHz | Reading Level dBuV/m | Correct Factor dB | Measure ment dBuV/m | Limit dBuV/m | Margin dB | Detector | Comment |
|-----|--------------|----------------------------|-------------------------|---------------------------|-----------------|--------------|----------|---------|
| 1 * | 30.0000 | 38.08 | -14.03 | 24.05 | 40.00 | -15.95 | Peak | |
| 2 | 71.7100 | 39.47 | -16.55 | 22.92 | 40.00 | -17.08 | Peak | |
| 3 | 168.7100 | 35.73 | -12.23 | 23.50 | 43.50 | -20.00 | Peak | |
| 4 | 234.6700 | 34.92 | -13.56 | 21.36 | 46.00 | -24.64 | Peak | |
| 5 | 428.6700 | 31.81 | -7.91 | 23.90 | 46.00 | -22.10 | Peak | |
| 6 | 558.6500 | 31.85 | -4.98 | 26.87 | 46.00 | -19.13 | Peak | |

ATTACHMENT D - RADIATED EMISSION (ABOVE 1000MHZ)

Test Mode : TX 2402MHz _CH00_1Mbps

Vertical

120 dBuV/m

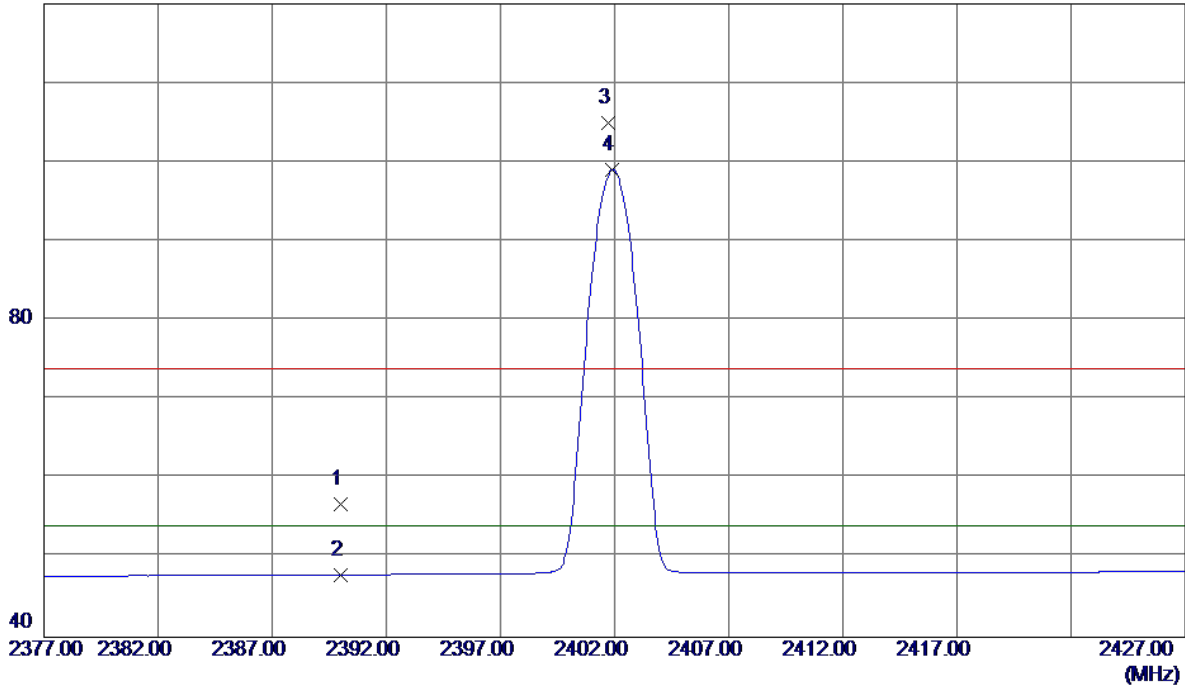

| No. | Freq. MHz | Reading Level dBuV/m | Correct Factor dB | Measure ment dBuV/m | Limit dBuV/m | Margin dB | Detector | Comment |
|-----|--------------|----------------------------|-------------------------|---------------------------|-----------------|--------------|----------|----------|
| 1 | 2390.0000 | 23.75 | 33.01 | 56.76 | 74.00 | -17.24 | Peak | |
| 2 | 2390.0000 | 14.85 | 33.01 | 47.86 | 54.00 | -6.14 | AVG | |
| 3 | 2401.7000 | 71.97 | 33.06 | 105.03 | 74.00 | 31.03 | Peak | No Limit |
| 4 * | 2401.9000 | 65.99 | 33.06 | 99.05 | 54.00 | 45.05 | AVG | No Limit |

Test Mode : TX 2402MHz _CH00_1Mbps

Vertical

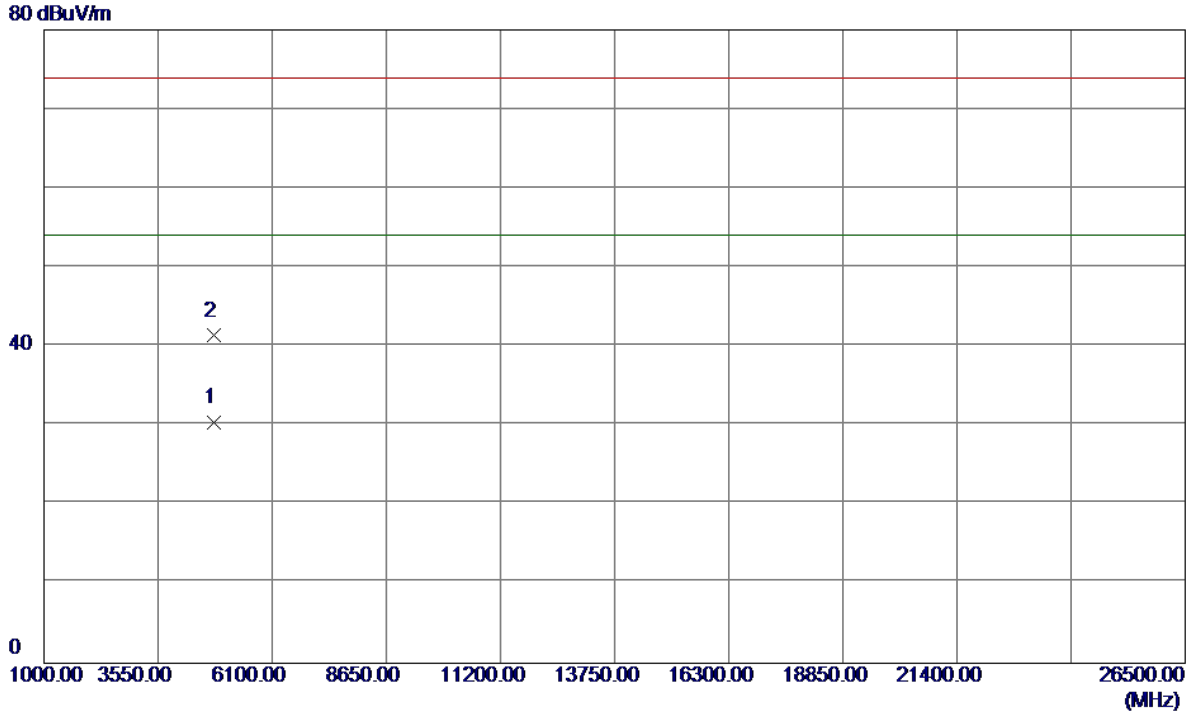

| No. | Freq. MHz | Reading Level dBuV/m | Correct Factor dB | Measure ment dBuV/m | Limit dBuV/m | Margin dB | Detector | Comment |
|-----|--------------|----------------------------|-------------------------|---------------------------|-----------------|--------------|----------|---------|
| 1 * | 4803.6549 | 25.60 | 4.77 | 30.37 | 54.00 | -23.63 | AVG | |
| 2 | 4804.1250 | 36.59 | 4.77 | 41.36 | 74.00 | -32.64 | Peak | |

Test Mode : TX 2402MHz _CH00_1Mbps

Horizontal

120 dBuV/m

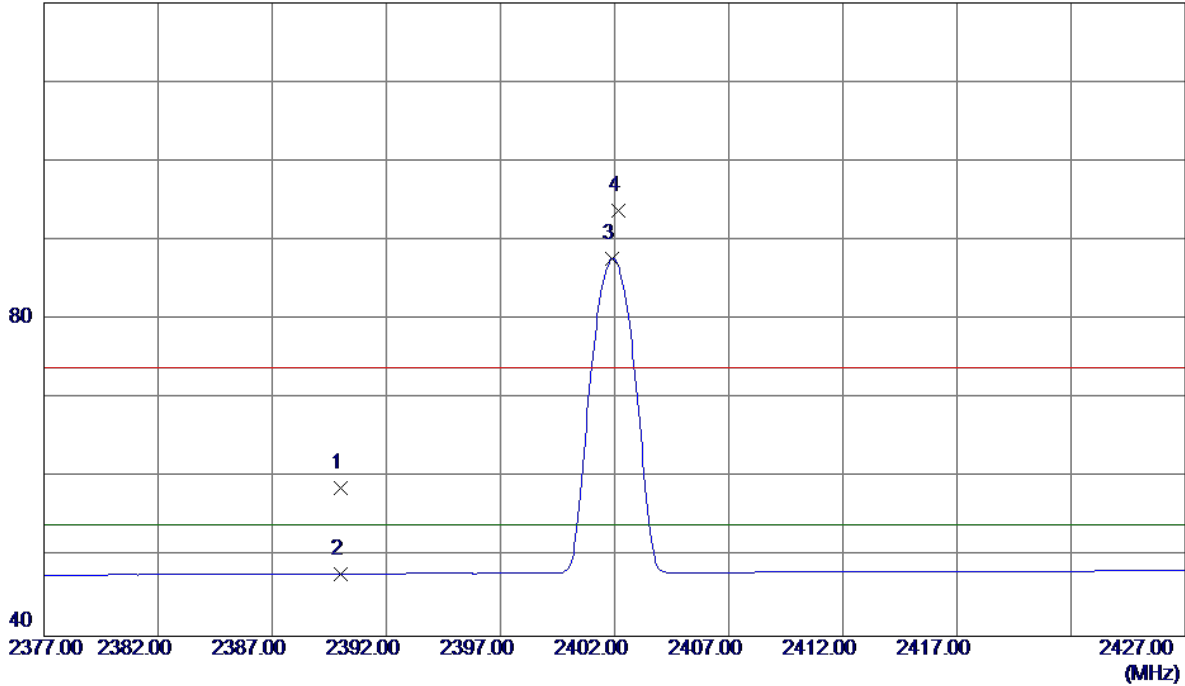

| No. | Freq. MHz | Reading Level dBuV/m | Correct Factor dB | Measure ment dBuV/m | Limit dBuV/m | Margin dB | Detector | Comment |
|-----|--------------|----------------------------|-------------------------|---------------------------|-----------------|--------------|----------|----------|
| 1 | 2390.0000 | 25.76 | 33.01 | 58.77 | 74.00 | -15.23 | Peak | |
| 2 | 2390.0000 | 14.84 | 33.01 | 47.85 | 54.00 | -6.15 | AVG | |
| 3 * | 2401.9000 | 54.65 | 33.06 | 87.71 | 54.00 | 33.71 | AVG | No Limit |
| 4 | 2402.1500 | 60.77 | 33.06 | 93.83 | 74.00 | 19.83 | Peak | No Limit |

Test Mode : TX 2402MHz _CH00_1Mbps

Horizontal



| No. | Freq. MHz | Reading Level dBuV/m | Correct Factor dB | Measure ment dBuV/m | Limit dBuV/m | Margin dB | Detector | Comment |
|-----|--------------|----------------------------|-------------------------|---------------------------|-----------------|--------------|----------|---------|
| 1 | 4804.0000 | 35.06 | 4.77 | 39.83 | 74.00 | -34.17 | Peak | |
| 2 * | 4804.0000 | 22.86 | 4.77 | 27.63 | 54.00 | -26.37 | AVG | |

Test Mode : TX 2440MHz _CH19_ 1Mbps

Vertical

120 dBuV/m

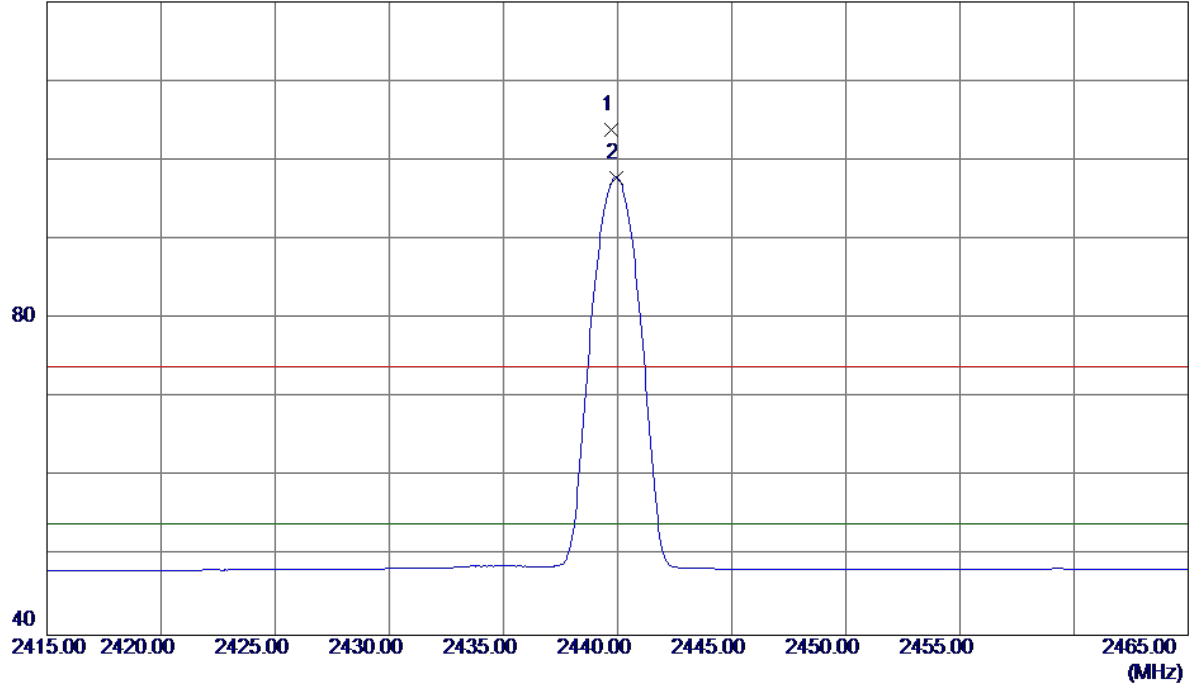

| No. | Freq. MHz | Reading Level dBuV/m | Correct Factor dB | Measure ment dBuV/m | Limit dBuV/m | Margin dB | Detector | Comment |
|-----|--------------|----------------------------|-------------------------|---------------------------|-----------------|--------------|----------|----------|
| 1 | 2439.7000 | 70.59 | 33.22 | 103.81 | 74.00 | 29.81 | Peak | No Limit |
| 2 * | 2439.9500 | 64.62 | 33.22 | 97.84 | 54.00 | 43.84 | AVG | No Limit |

Test Mode : TX 2440MHz _CH19_1Mbps

Vertical

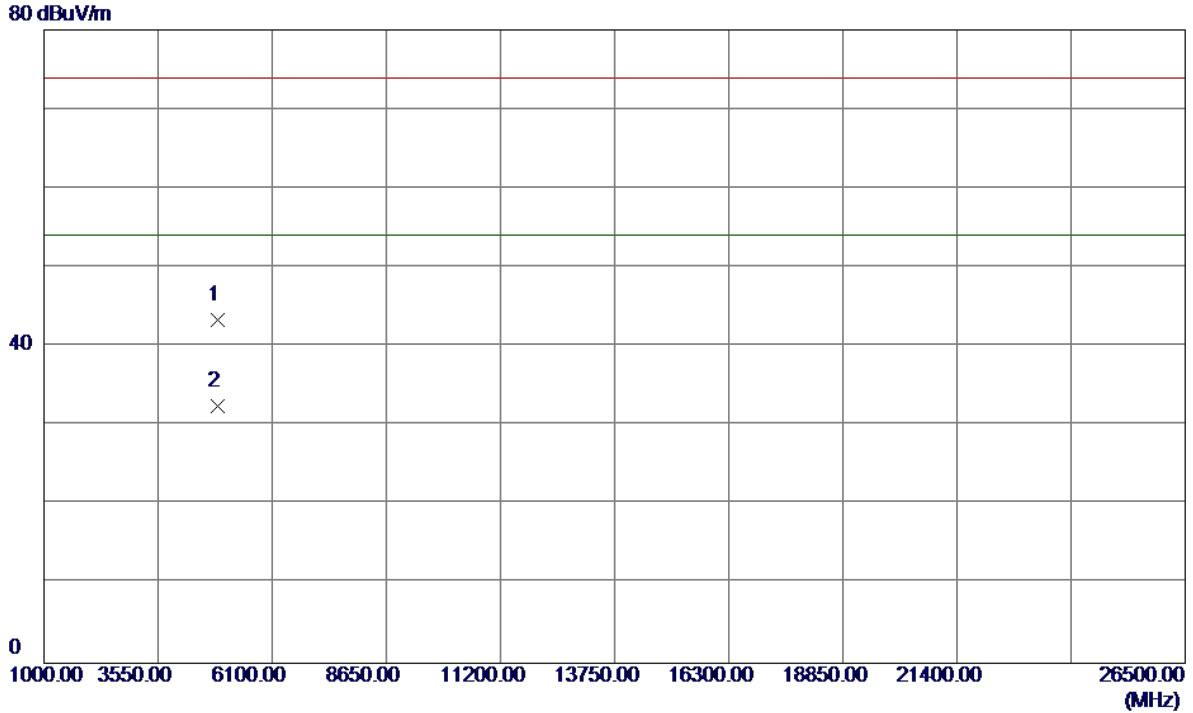

| No. | Freq. MHz | Reading Level dBuV/m | Correct Factor dB | Measure ment dBuV/m | Limit dBuV/m | Margin dB | Detector | Comment |
|-----|--------------|----------------------------|-------------------------|---------------------------|-----------------|--------------|----------|---------|
| 1 | 4879.5650 | 38.28 | 5.09 | 43.37 | 74.00 | -30.63 | Peak | |
| 2 * | 4879.6050 | 27.35 | 5.09 | 32.44 | 54.00 | -21.56 | AVG | |

Test Mode : TX 2440MHz _CH19_1Mbps

Horizontal

120 dBuV/m

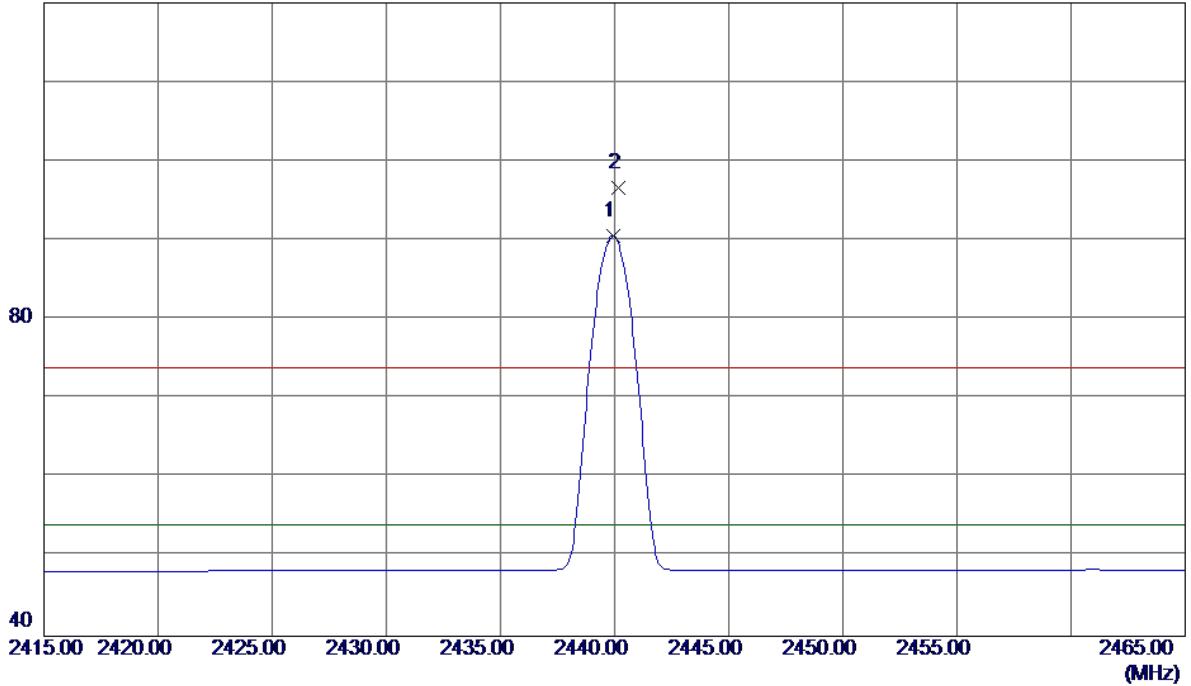

| No. | Freq. MHz | Reading Level dBuV/m | Correct Factor dB | Measure ment dBuV/m | Limit dBuV/m | Margin dB | Detector | Comment |
|-----|--------------|----------------------------|-------------------------|---------------------------|-----------------|--------------|----------|----------|
| 1 * | 2439.9500 | 57.38 | 33.22 | 90.60 | 54.00 | 36.60 | AVG | No Limit |
| 2 | 2440.1500 | 63.35 | 33.22 | 96.57 | 74.00 | 22.57 | Peak | No Limit |

Test Mode : TX 2440MHz _CH19_1Mbps

Horizontal

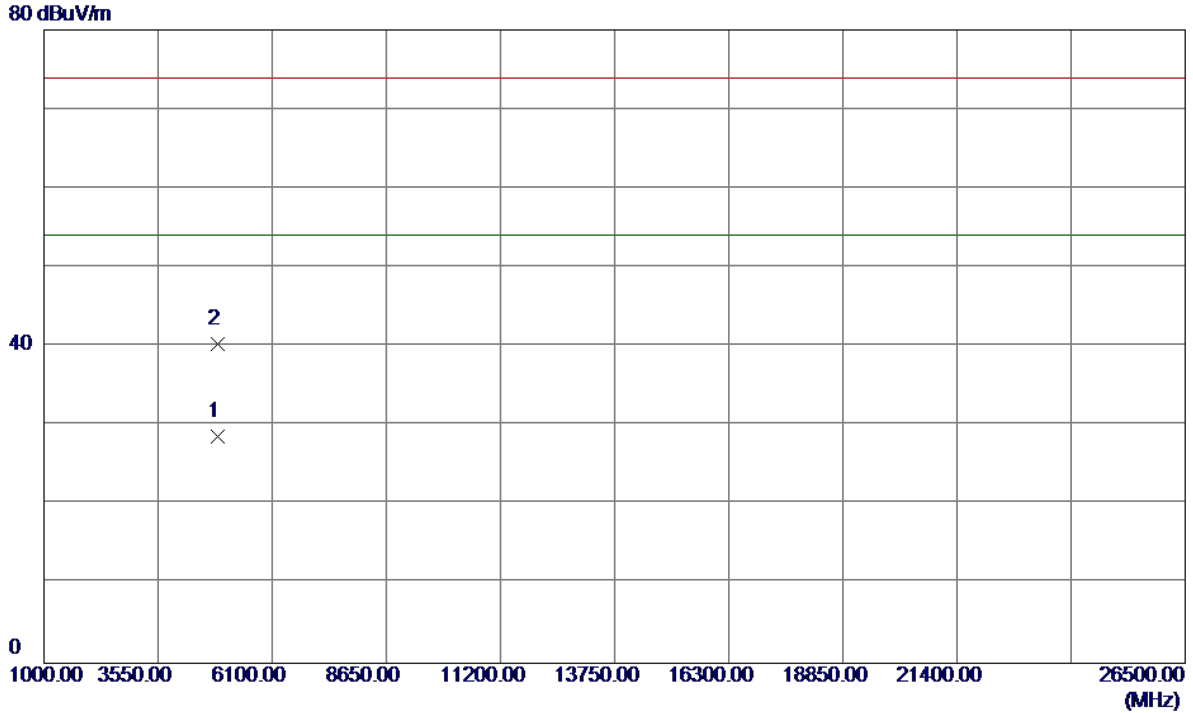

| No. | Freq. MHz | Reading Level dBuV/m | Correct Factor dB | Measure ment dBuV/m | Limit dBuV/m | Margin dB | Detector | Comment |
|-----|--------------|----------------------------|-------------------------|---------------------------|-----------------|--------------|----------|---------|
| 1 * | 4879.5050 | 23.52 | 5.09 | 28.61 | 54.00 | -25.39 | AVG | |
| 2 | 4880.1750 | 35.24 | 5.09 | 40.33 | 74.00 | -33.67 | Peak | |

Test Mode : TX 2480MHz _CH39_1Mbps

Vertical

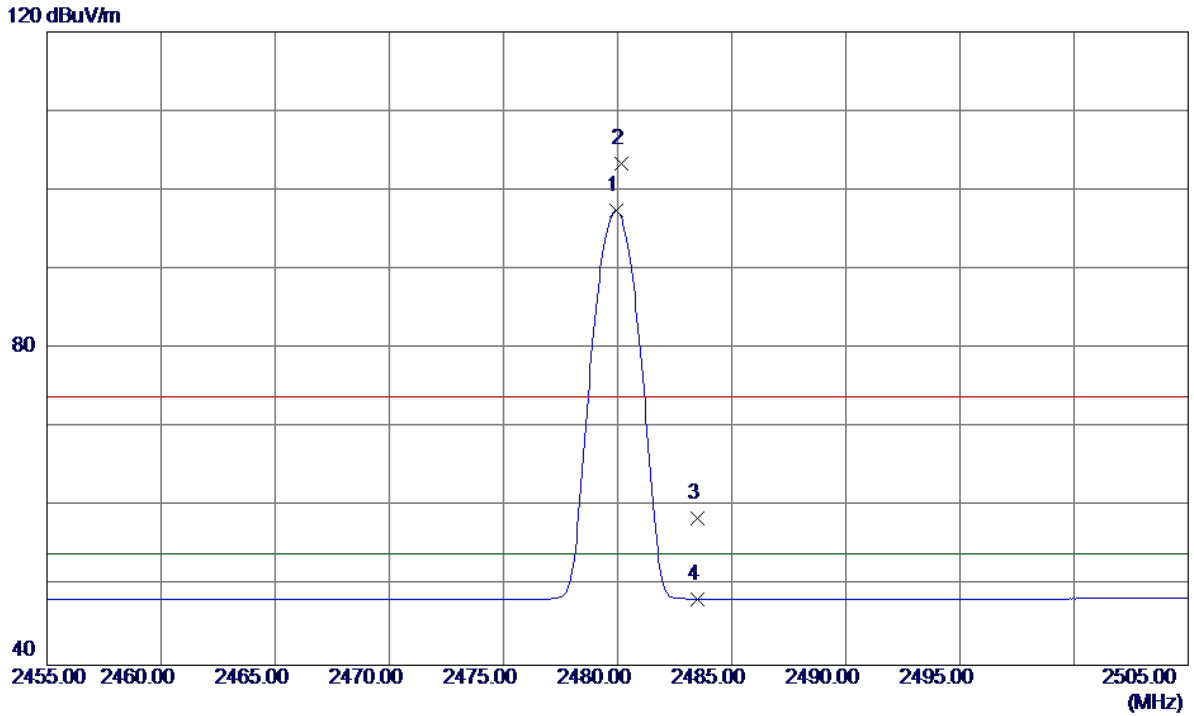

| No. | Freq. MHz | Reading Level dBuV/m | Correct Factor dB | Measure ment dBuV/m | Limit dBuV/m | Margin dB | Detector | Comment |
|-----|--------------|----------------------------|-------------------------|---------------------------|-----------------|--------------|----------|----------|
| 1 * | 2479.9500 | 63.99 | 33.39 | 97.38 | 54.00 | 43.38 | AVG | No Limit |
| 2 | 2480.1500 | 69.95 | 33.39 | 103.34 | 74.00 | 29.34 | Peak | No Limit |
| 3 | 2483.5000 | 25.13 | 33.40 | 58.53 | 74.00 | -15.47 | Peak | |
| 4 | 2483.5000 | 14.97 | 33.40 | 48.37 | 54.00 | -5.63 | AVG | |

Test Mode : TX 2480MHz _CH39_1Mbps

Vertical

80 dBuV/m



| No. | Freq. MHz | Reading Level dBuV/m | Correct Factor dB | Measure ment dBuV/m | Limit dBuV/m | Margin dB | Detector | Comment |
|-----|--------------|----------------------------|-------------------------|---------------------------|-----------------|--------------|----------|---------|
| 1 | 4959.5000 | 39.59 | 5.43 | 45.02 | 74.00 | -28.98 | Peak | |
| 2 * | 4959.6700 | 29.18 | 5.43 | 34.61 | 54.00 | -19.39 | AVG | |

Test Mode : TX 2480MHz _CH39_1Mbps

Horizontal

120 dBuV/m

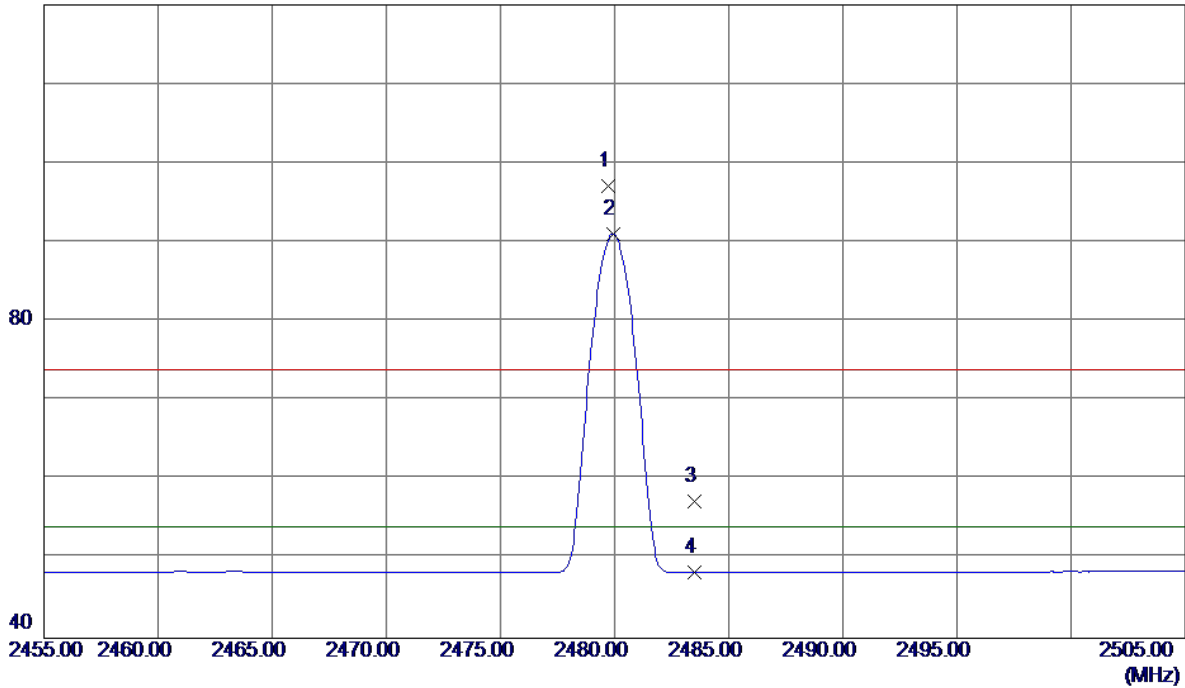

| No. | Freq. MHz | Reading Level dBuV/m | Correct Factor dB | Measure ment dBuV/m | Limit dBuV/m | Margin dB | Detector | Comment |
|-----|--------------|----------------------------|-------------------------|---------------------------|-----------------|--------------|----------|----------|
| 1 | 2479.7000 | 63.66 | 33.39 | 97.05 | 74.00 | 23.05 | Peak | No Limit |
| 2 * | 2479.9500 | 57.66 | 33.39 | 91.05 | 54.00 | 37.05 | AVG | No Limit |
| 3 | 2483.5000 | 23.84 | 33.40 | 57.24 | 74.00 | -16.76 | Peak | |
| 4 | 2483.5000 | 14.89 | 33.40 | 48.29 | 54.00 | -5.71 | AVG | |

Test Mode : TX 2480MHz _CH39_1Mbps

Horizontal

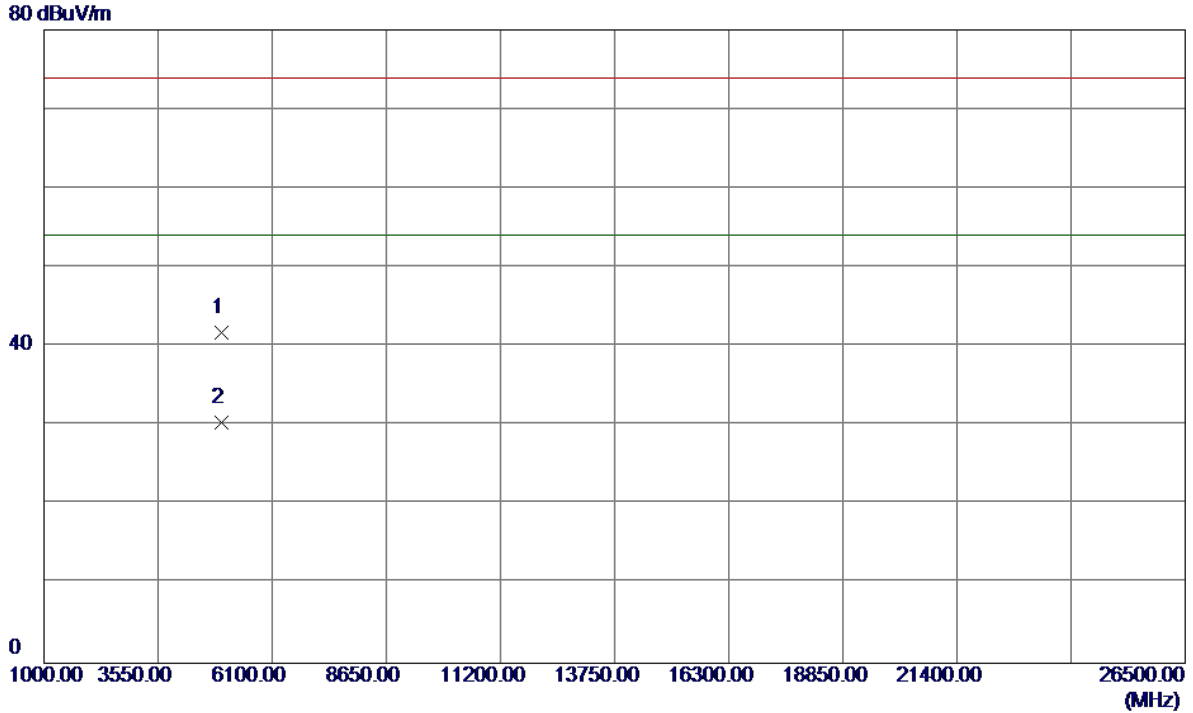

| No. | Freq. MHz | Reading Level dBuV/m | Correct Factor dB | Measure ment dBuV/m | Limit dBuV/m | Margin dB | Detector | Comment |
|-----|--------------|----------------------------|-------------------------|---------------------------|-----------------|--------------|----------|---------|
| 1 | 4959.3600 | 36.35 | 5.43 | 41.78 | 74.00 | -32.22 | Peak | |
| 2 * | 4959.5200 | 24.92 | 5.43 | 30.35 | 54.00 | -23.65 | AVG | |

ATTACHMENT E - BANDWIDTH

Test Mode: TX Mode

| Frequency (MHz) | 6dB Bandwidth (MHz) | 99% Occupied BW (MHz) | Min. Limit (kHz) | Test Result |
|-----------------|---------------------|-----------------------|------------------|-------------|
| 2402 | 0.492 | 1.084 | 500 | Pass |
| 2440 | 0.504 | 1.096 | 500 | Pass |
| 2480 | 0.504 | 1.096 | 500 | Pass |

TX CH00

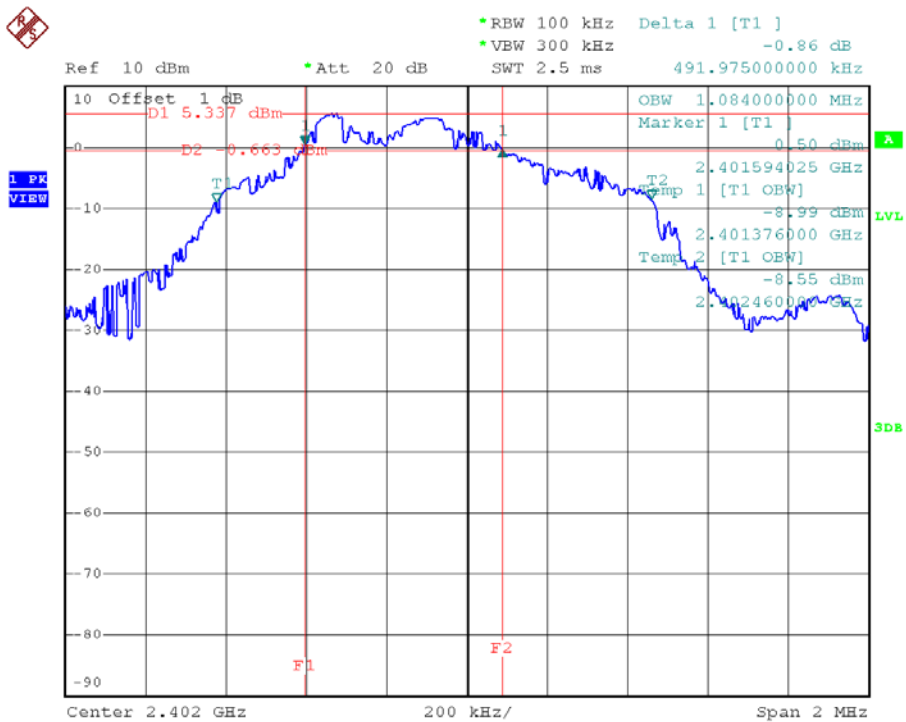

Date: 20.MAR.2017 10:16:05

TX CH19

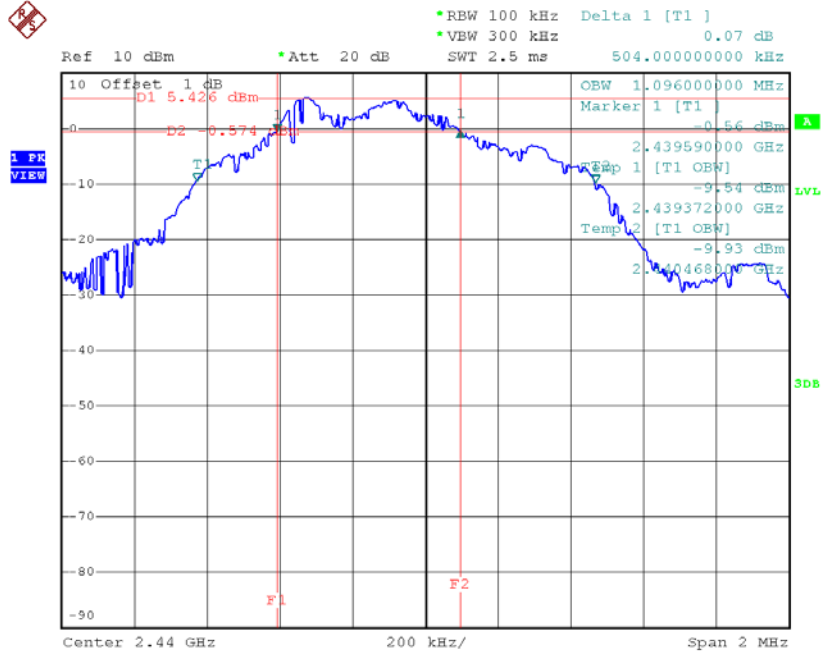

Date: 20.MAR.2017 10:22:53

TX CH39

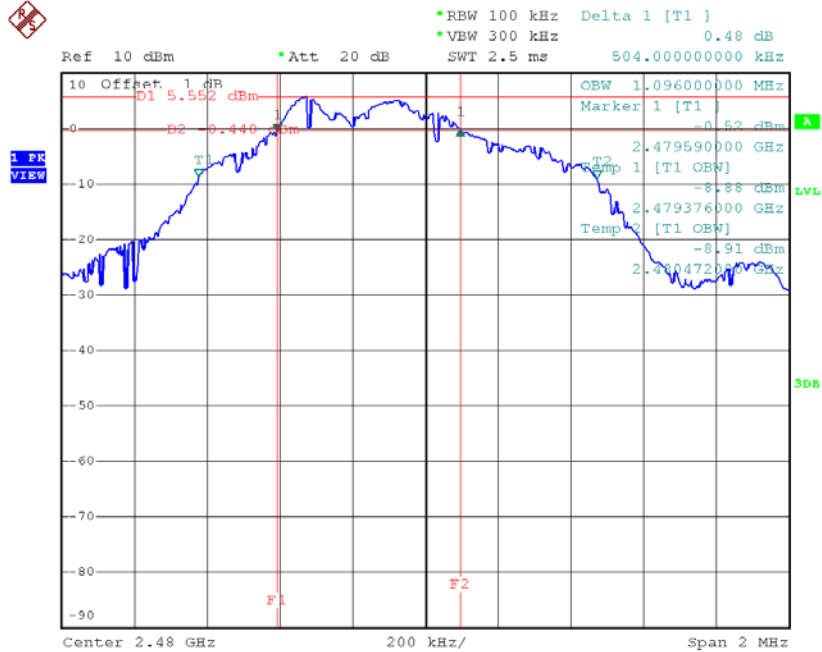

Date: 20.MAR.2017 10:26:06

ATTACHMENT F - MAXIMUM OUTPUT POWER TEST

Test Mode : CH00, CH19 , CH39 - 1Mbps

| Frequency (MHz) | Conducted Power (dBm) | Conducted Power (W) | Max. Limit (dBm) | Max. Limit (W) | Test Result |
|-----------------|-----------------------|---------------------|------------------|----------------|-------------|
| 2402 | 4.40 | 0.00275 | 30.00 | 1.00 | Pass |
| 2440 | 4.92 | 0.00310 | 30.00 | 1.00 | Pass |
| 2480 | 3.59 | 0.00229 | 30.00 | 1.00 | Pass |

ATTACHMENT G - ANTENNA CONDUCTED SPURIOUS EMISSION

Test Mode : CH00, CH19 , CH39 - 1Mbps

CH00 (Lower) - 1Mbps

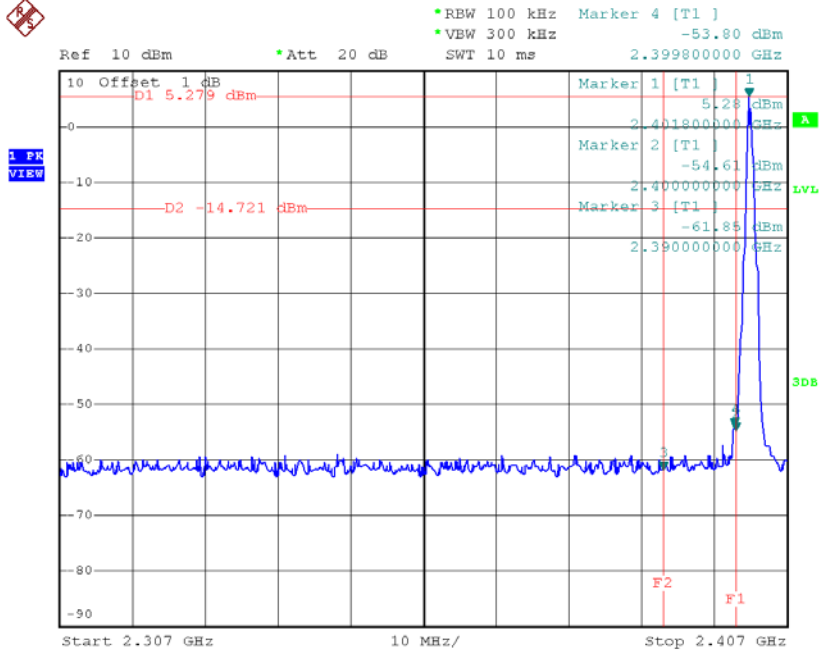

Date: 20.MAR.2017 10:16:13

CH39 (upper) - 1Mbps

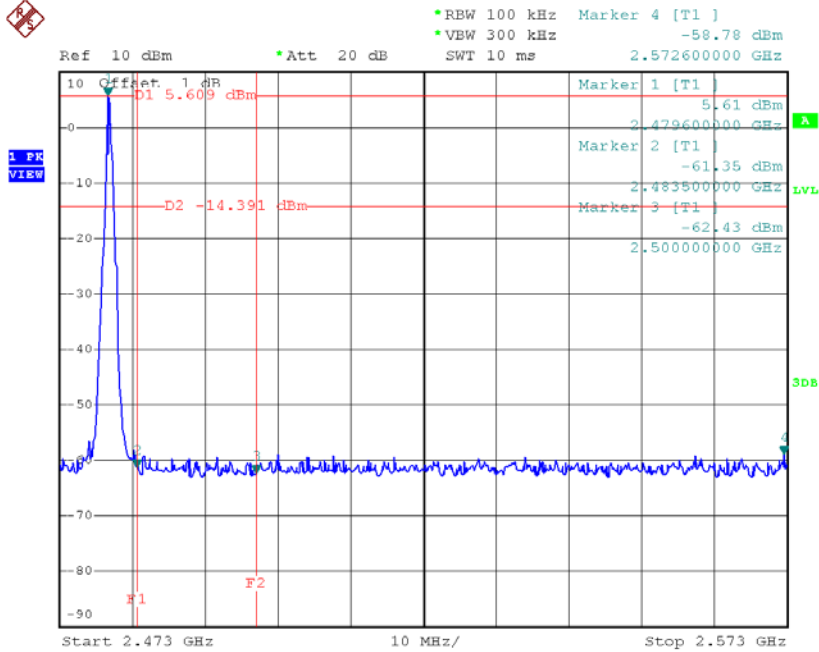

Date: 20.MAR.2017 10:26:15

CH00 (10 Harmonic of the frequency) 1

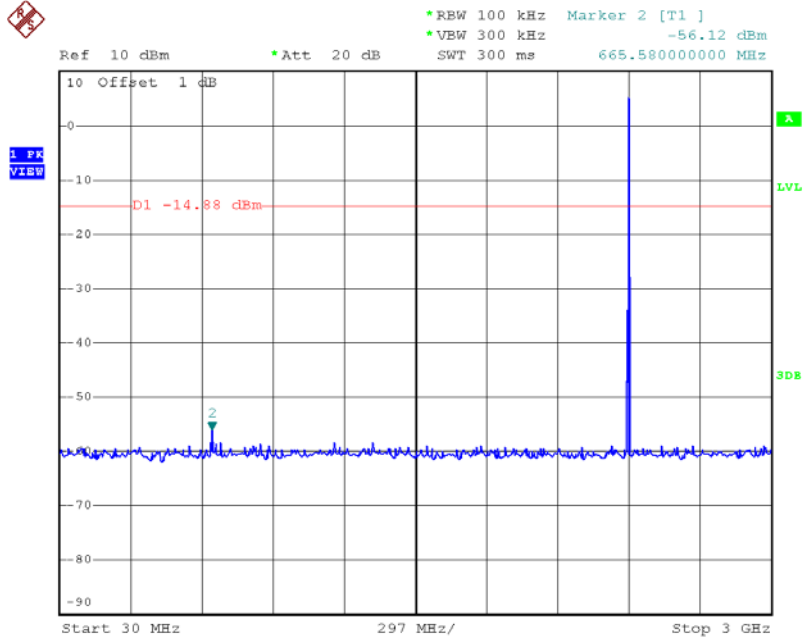

Date: 20.MAR.2017 10:16:29

CH00 (10 Harmonic of the frequency) 2

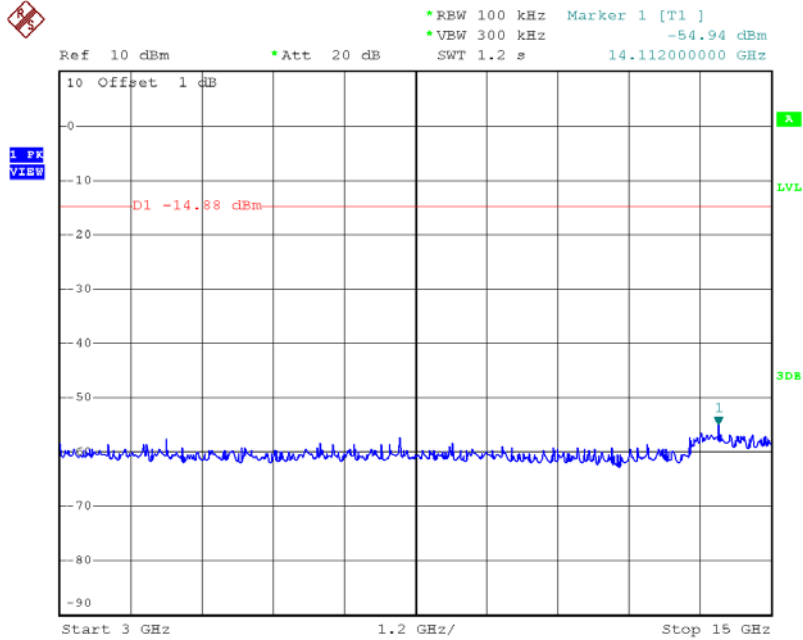

Date: 20.MAR.2017 10:16:38

CH00 (10 Harmonic of the frequency) 3

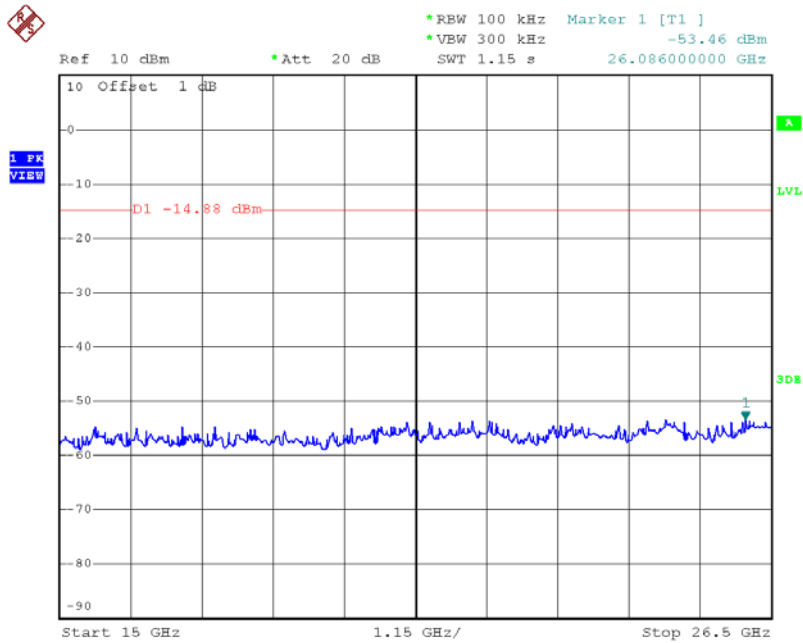

Date: 20.MAR.2017 10:16:46

CH19 (10 Harmonic of the frequency) 1

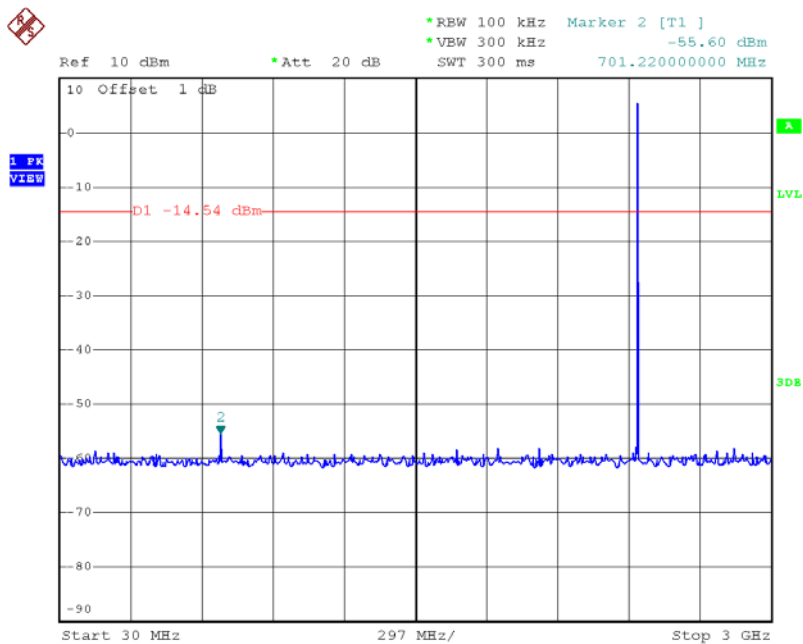

Date: 20.MAR.2017 10:23:07

CH19 (10 Harmonic of the frequency) 2

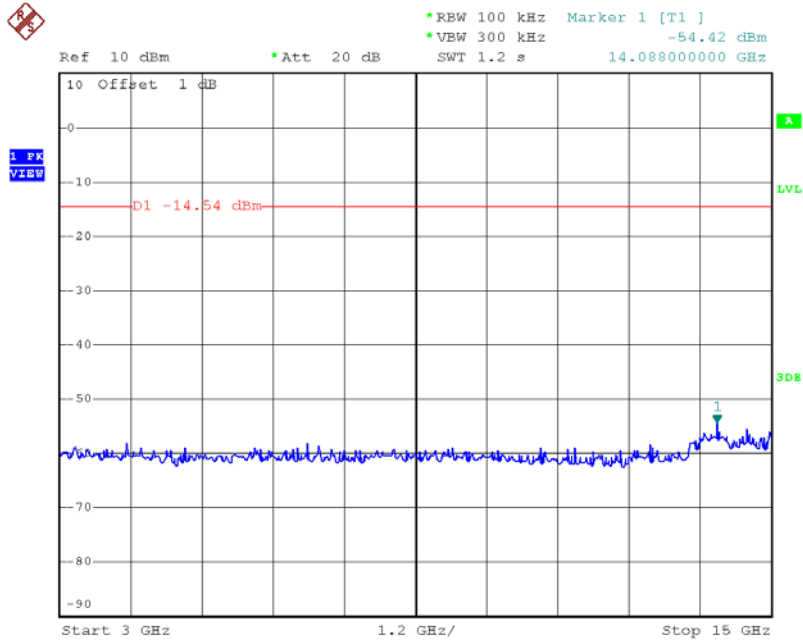

Date: 20.MAR.2017 10:23:15

CH19 (10 Harmonic of the frequency) 3

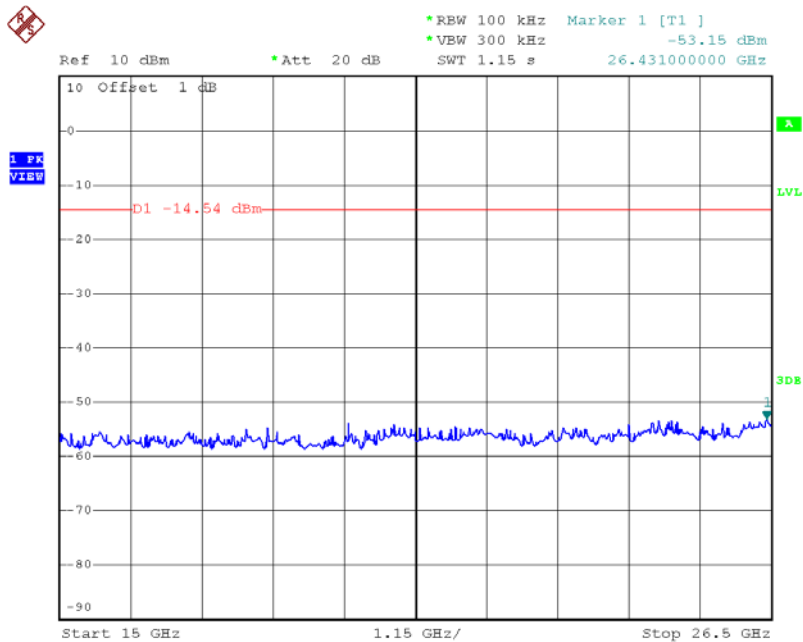

Date: 20.MAR.2017 10:23:24

CH39 (10 Harmonic of the frequency) 1

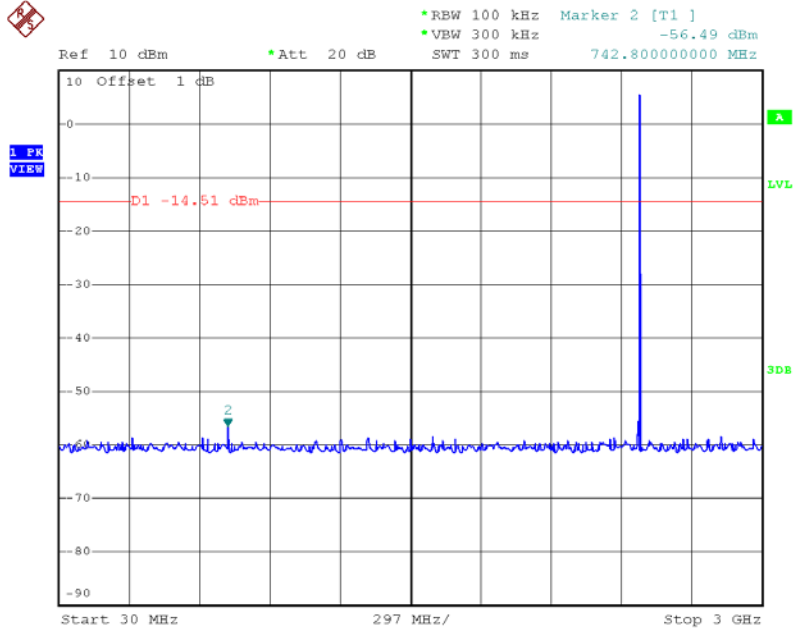

Date: 20.MAR.2017 10:26:28

CH39 (10 Harmonic of the frequency) 2

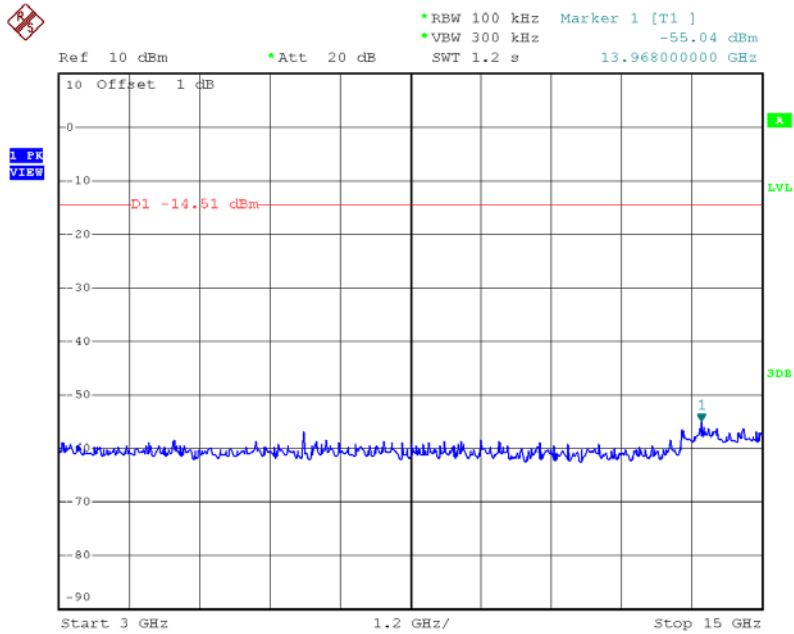

Date: 20.MAR.2017 10:26:37

CH39 (10 Harmonic of the frequency) 3

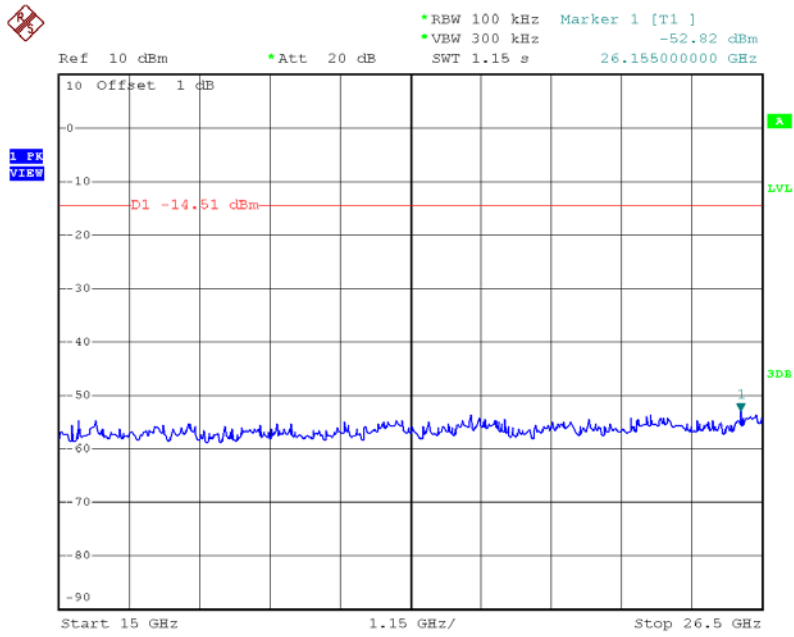

Date: 20.MAR.2017 10:26:45

ATTACHMENT H - POWER SPECTRAL DENSITY TEST

Test Mode: CH00, CH19 , CH39 - 1Mbps

| Frequency (MHz) | Power Density (dBm/3kHz) | Power Density (mW/3kHz) | Max. Limit (dBm/3kHz) | Test Result |
|-----------------|--------------------------|-------------------------|-----------------------|-------------|
| 2402 | -11.980 | 0.063 | 8.00 | Pass |
| 2440 | -11.940 | 0.064 | 8.00 | Pass |
| 2480 | -11.750 | 0.067 | 8.00 | Pass |

TX CH00

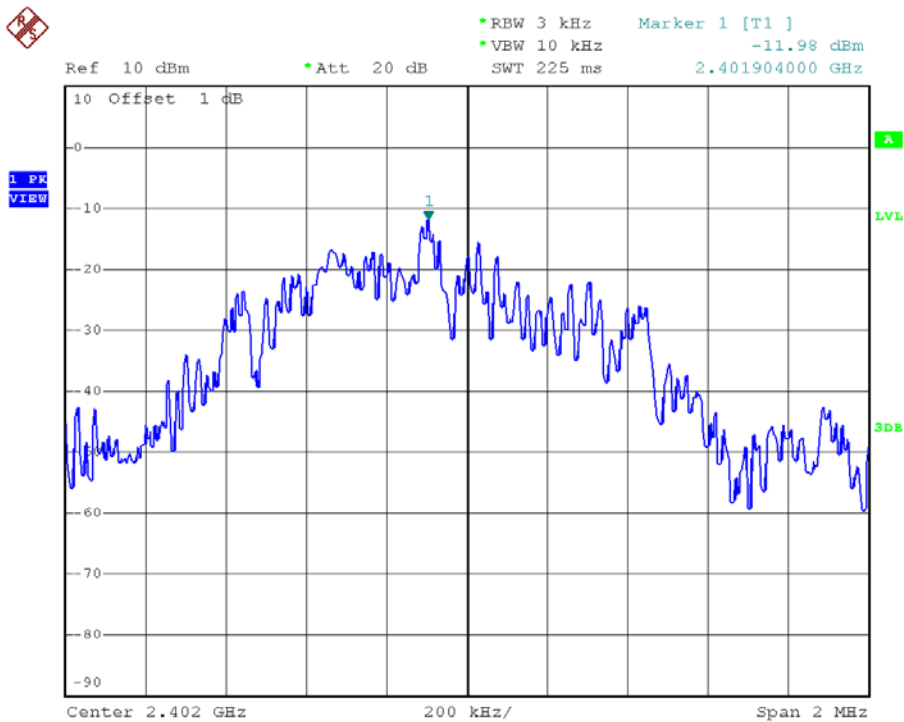

Date: 20.MAR.2017 10:21:31

TX CH19

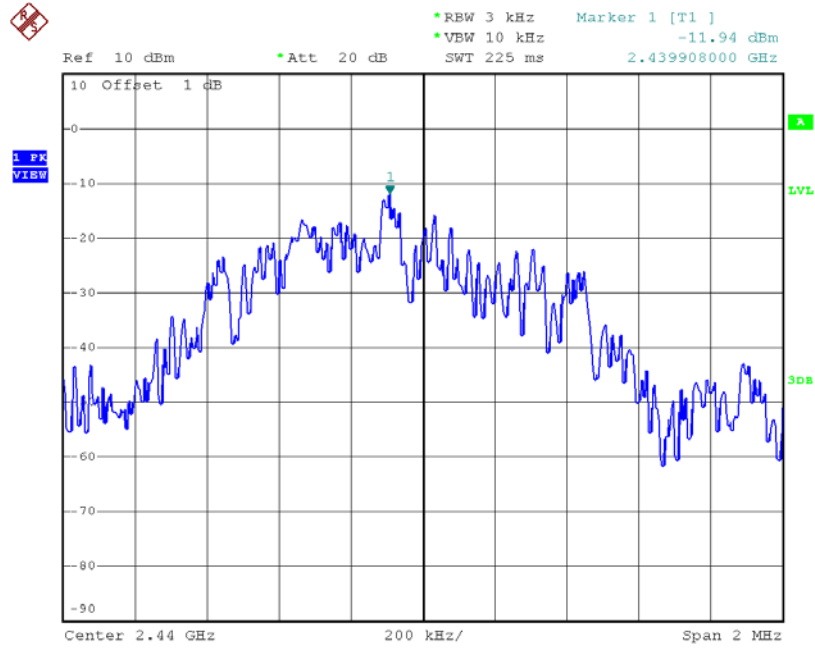

Date: 20.MAR.2017 10:23:30

TX CH39

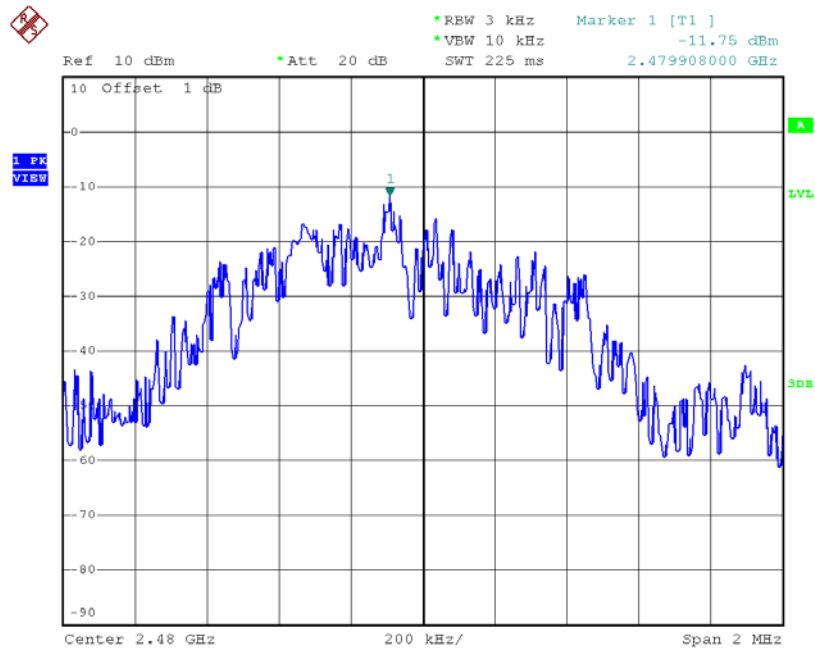

Date: 20.MAR.2017 10:26:51